

# 3GPP TS 24.647 V11.1.0 (2011-12)

---

*Technical Specification*

## **3rd Generation Partnership Project; Technical Specification Group Core Network and Terminals; Advice Of Charge (AOC) using IP Multimedia (IM) Core Network (CN) subsystem (Release 11)**



The present document has been developed within the 3<sup>rd</sup> Generation Partnership Project (3GPP<sup>TM</sup>) and may be further elaborated for the purposes of 3GPP. The present document has not been subject to any approval process by the 3GPP Organizational Partners and shall not be implemented. This Specification is provided for future development work within 3GPP only. The Organizational Partners accept no liability for any use of this Specification. Specifications and reports for implementation of the 3GPP<sup>TM</sup> system should be obtained via the 3GPP Organizational Partners' Publications Offices.

---

Keywords

---

AOC, ISDN, PSTN, supplementary service, LTE,  
UMTS, GSM

**3GPP**

Postal address

---

3GPP support office address

---

650 Route des Lucioles - Sophia Antipolis  
Valbonne - FRANCE  
Tel.: +33 4 92 94 42 00 Fax: +33 4 93 65 47 16

Internet

---

<http://www.3gpp.org>

---

**Copyright Notification**

---

No part may be reproduced except as authorized by written permission.  
The copyright and the foregoing restriction extend to reproduction in all media.

© 2011, 3GPP Organizational Partners (ARIB, ATIS, CCSA, ETSI, TTA, TTC).  
All rights reserved.

UMTS™ is a Trade Mark of ETSI registered for the benefit of its members  
3GPP™ is a Trade Mark of ETSI registered for the benefit of its Members and of the 3GPP Organizational Partners  
LTE™ is a Trade Mark of ETSI currently being registered for the benefit of its Members and of the 3GPP Organizational Partners  
GSM® and the GSM logo are registered and owned by the GSM Association

# Contents

Foreword .....	6
1 Scope .....	7
2 References.....	7
3 Definitions and abbreviations .....	8
3.1 Definitions .....	8
3.2 Abbreviations .....	8
4 Advice Of Charge (AOC).....	9
4.1 Introduction .....	9
4.2 Description.....	9
4.2.1 General description .....	9
4.2.2 Charging information at communication set-up time (AOC-S).....	9
4.3 Charging information during the communication (AOC-D) .....	9
4.4 Charging information at the end of the communication (AOC-E) .....	9
4.5 Operational requirements .....	9
4.5.1 Provision/withdrawal.....	9
4.5.2 Requirements on the originating network side.....	9
4.5.3 Requirements on the terminating network side.....	10
4.6 Coding requirements.....	10
4.7 Signalling requirements.....	10
4.7.1 Activation/deactivation .....	10
4.7.1A Registration/erasure .....	10
4.7.1B Interrogation.....	10
4.7.2 Invocation and operation.....	10
4.7.2.0 Introduction.....	10
4.7.2.1 Actions at the served UE .....	10
4.7.2.2 Actions at the AS of the served user.....	11
4.7.2.2.0 General.....	11
4.7.2.2.1 Actions for AOC-S .....	11
4.7.2.2.1.1 Served user is the originating user.....	11
4.7.2.2.1.2 Served user is the terminating user.....	11
4.7.2.2.2 Actions for AOC-D .....	12
4.7.2.2.3 Actions for AOC-E.....	12
4.8 Interaction with other services .....	12
4.8.1 Communication Waiting (CW).....	12
4.8.2 Communication Hold (HOLD) .....	12
4.8.3 Terminating Identification Presentation (TIP) .....	12
4.8.4 Terminating Identification Restriction (TIR) .....	12
4.8.5 Originating Identification Presentation (OIP) .....	12
4.8.6 Originating Identification Restriction (OIR) .....	13
4.8.7 CONference calling (CONF) .....	13
4.8.8 Communication DIVersion services (CDIV) .....	13
4.8.9 Advice Of Charge (AOC) .....	13
4.8.10 Completion of Communications to Busy Subscriber (CCBS) Completion of Communications by No Reply (CCNR) .....	13
4.8.11 Malicious Communication IDentification (MCID).....	13
4.8.12 Anonymous Communication Rejection and Communication Barring (ACR/CB) .....	13
4.8.13 Explicit Communication Transfer (ECT).....	13
4.9 Interactions with other networks.....	13
4.10 Parameter values (timers).....	13
5 Extensions within the present document .....	14
5.1 AOC information XML body.....	14
5.1.1 General .....	14
5.1.2 MIME type definition .....	14
5.1.2.1 Introduction.....	14

5.1.2.2	Syntax .....	14
5.1.2.3	Operation .....	14
<b>Annex A (informative): Signalling flows.....</b>		<b>15</b>
A.1	Introduction .....	15
A.2	User originating AOC service .....	15
A.2.1	AOC-S .....	15
A.2.1.1	AOC-S with AOC information in reliable 1xx responses .....	15
A.2.1.2	AOC-S with AOC information in a 200 (OK) response .....	16
A.2.1.3	AOC-S with AOC information in INFO messages .....	17
A.2.2	AOC-D .....	17
1-4	In order to send an update on the cumulative charge incurred so far, an INFO request is send from the Originating AS to UE-A. The AOC information is included in the INFO request.A.2.3 AOC-E .....	18
A.3	User terminating AOC service .....	20
A.3.1	AOC-S .....	20
A.3.1.1	AOC-S with AOC information during session set-up .....	20
A.3.1.2	AOC-S with AOC information in INFO messages .....	21
A.3.2	AOC-D .....	21
A.3.3	AOC-E.....	22
<b>Annex B (informative): Example of Filter Criteria.....</b>		<b>24</b>
<b>Annex C (normative): Charging Information Elements .....</b>		<b>25</b>
C.1	General.....	25
C.2	AOC-S.....	25
C.2.1	Charged Items .....	25
C.2.1.1	Charged Item: basic communication .....	25
C.2.1.2	Charged Item: communication attempt .....	25
C.2.1.3	Charged Item: communication setup .....	25
C.2.1.4	Charged Item: operation of services .....	26
C.2.1.5	Void .....	26
C.2.2	Expressing Charging Rates .....	26
C.2.2.1	Duration charge: Price per time unit, and unit time .....	26
C.2.2.2	Specific: free of charge .....	26
C.2.2.3	Specific: flat rate .....	26
C.2.2.4	Void .....	27
C.2.2.5	Charging unit .....	27
C.2.2.6	Not available .....	27
C.3	AOC-D.....	27
C.3.1	Type of charging information.....	27
C.3.2	Recorded charges.....	27
C.3.3	Void .....	27
C.4	AOC-E.....	27
C.4.1	Void .....	28
C.5	Common types/information elements.....	28
C.5.1	Time unit .....	28
C.5.2	Decimal .....	28
C.5.3	Scale .....	28
C.5.4	Currency identifier .....	28
C.5.5	Currency amount .....	28
C.5.6	Length of time unit .....	28
C.5.7	Granularity .....	28
C.5.8	Type of charging.....	29
C.5.9	Recorded number of currency units .....	29
C.6	Charge Advice Information (CAI).....	29
C.6.1	General .....	29

C.6.2	CAI items .....	29
C.6.2.1	General .....	29
C.6.2.2	Initial cost .....	29
C.6.2.3	Time related .....	29
C.6.2.4	Volume related .....	29
<b>Annex D (normative):</b>	<b>AOC XML Schema, version 1.0:.....</b>	<b>31</b>
D.1	Basic XML schema .....	31
D.2	Extensions .....	33
<b>Annex E (informative):</b>	<b>IANA Registration templates .....</b>	<b>34</b>
E.1	IANA registry for Application Media Types .....	34
E.1.1	IANA Registration template for application/vnd.etsi.aoc+xml .....	34
<b>Annex F (informative):</b>	<b>Change history.....</b>	<b>36</b>

---

## Foreword

This Technical Specification (TS) was been produced by ETSI Technical Committee Telecommunications and Internet converged Services and Protocols for Advanced Networking (TISPAN) and originally published as ETSI TS 183 047 [6]. It was transferred to the 3<sup>rd</sup> Generation Partnership Project (3GPP) in December 2007.

The contents of the present document are subject to continuing work within the TSG and may change following formal TSG approval. Should the TSG modify the contents of the present document, it will be re-released by the TSG with an identifying change of release date and an increase in version number as follows:

Version x.y.z

where:

- x the first digit:
  - 1 presented to TSG for information;
  - 2 presented to TSG for approval;
  - 3 or greater indicates TSG approved document under change control.
- y the second digit is incremented for all changes of substance, i.e. technical enhancements, corrections, updates, etc.
- z the third digit is incremented when editorial only changes have been incorporated in the document.

---

# 1 Scope

The present document specifies the stage three Protocol Description of the Advice Of Charge (AOC) service, based on stage 1 and 2 of the ISDN Supplementary Service Advice Of Charge for all calls (permanent mode). It provides the protocol details in the IP Multimedia (IM) Core Network (CN) subsystem based on the Session Initiation Protocol (SIP) and the Session Description Protocol (SDP).

Three AOC services exist:

**a) Charging information at communication set-up time (AOC-S)**

The AOC-S service enables a user to receive information about the charging rates at communication set-up time and also to receive further information during the communication if there is a change of charging rates.

**b) Charging information during the communication (AOC-D)**

The AOC-D service enables a user to receive information on the recorded charges for a communication during the active phase of the communication.

**c) Charging information at the end of the communication (AOC-E)**

The AOC-E service enables a user to receive information on the recorded charges for a communication when the communication is terminated.

The present document is applicable to User Equipment (UE) and Application Servers (AS) which are intended to support the AOC supplementary services.

---

# 2 References

The following documents contain provisions which, through reference in this text, constitute provisions of the present document.

- References are either specific (identified by date of publication, edition number, version number, etc.) or non-specific.
- For a specific reference, subsequent revisions do not apply.
- For a non-specific reference, the latest version applies. In the case of a reference to a 3GPP document (including a GSM document), a non-specific reference implicitly refers to the latest version of that document *in the same Release as the present document*.

- [1] 3GPP TS 22.173: "IP Multimedia Core Network Subsystem (IMS) Multimedia Telephony Service and supplementary services; Stage 1".
- [2] 3GPP TS 24.229: "Internet Protocol (IP) multimedia call control protocol based on Session Initiation Protocol (SIP) and Session Description Protocol (SDP); Stage 3".
- [3] ISO 4217: "International Organization for Standardization; Type Currency Code List".
- [4] IETF RFC 6086 (October 2009): "Session Initiation Protocol (SIP) INFO Method and Package Framework".
- [5] IETF RFC 3262 (2002): "Reliability of Provisional Responses in the Session Initiation Protocol (SIP)".
- [6] ETSI TS 183 047 V2.1.1: "Telecommunications and Internet converged Services and Protocols for Advanced Networking (TISPAN); NGN IMS Supplementary Services; Advice Of Charge (AOC)".
- [7] IETF RFC 3261 (June 2002): "SIP: Session Initiation Protocol".
- [8] IETF RFC 3023 (January 2001): "XML Media Types".

- [9] IETF RFC 4288 (December 2005): "Media Type Specifications and Registration Procedures".
- [10] 3GPP TS 32.280: "Telecommunication management; Charging management; Advice of Charge (AoC) service".
- [11] 3GPP TS 22.024: "Description of Charge Advice Information (CAI)".

---

## 3 Definitions and abbreviations

### 3.1 Definitions

For the purposes of the present document, the terms and definitions given in 3GPP TS 22.173 [1] apply.

### 3.2 Abbreviations

For the purposes of the present document, the following abbreviations apply:

AOC	Advice Of Charge
AOC-D	AOC During the call
AOC-E	AOC at the End of the call
AOC-S	AOC at call Set-up time
AS	Application Server
CAI	Charge Advice Information
CB	Communication Barring
CCBS	Completion of Communication to Busy Subscriber.
CD	Communication Deflection
CDIV	Call DIVersion
CFB	Communication Forwarding Busy
CFNL	Communication Forwarding on No Logged-in
CFNRd	Communication Forwarding Not Registered
CFNRy	Communication Forwarding No Reply
CFU	Communication Forwarding Unconditional
CN	Core Network
CNR	Completion of communication on No Reply
CONF	CONFerence calling
CW	Communication Waiting
ECT	Explicit Communication Transfer
HOLD	Communication HOLD
IFC	Initial Filter Criteria
IM	IP Multimedia
IMS	IP Multimedia Subsystem
IP	Internet Protocol
ISDN	Integrated Service Data Network
MCID	Malicious Communication IDentification
MIME	Multipurpose Internet Mail Extensions
OIP	Originating Identification Presentation
OIR	Originating Identification Restriction
S-CSCF	Serving-Call Session Control Function
SIP	Session Initiation Protocol
TIP	Terminating Identification Presentation
TIR	Terminating Identification Restriction
UE	User Equipment



---

## 4 Advice Of Charge (AOC)

### 4.1 Introduction

The Advice Of Charge (AOC) service allows the served user to be informed of IP Multimedia session related charging information.

### 4.2 Description

#### 4.2.1 General description

The AOC service is limited to INVITE-initiated sessions.

The AOC service is not meant to replace the charge metering inside the network which is considered to be correct in all cases.

The charging information given shall relate to the charges incurred in the current network.

#### 4.2.2 Charging information at communication set-up time (AOC-S)

When the AOC-S service is activated, the network shall provide the user with information about the charging rates at communication establishment. In addition, the network shall inform the served user if a change in charging rates takes place during the communication.

### 4.3 Charging information during the communication (AOC-D)

When the AOC-D service is activated, the network shall provide the user with charging information for a communication during the active phase of this communication. The supplied charging information shall be provided as a cumulative charge incurred so far for the communication (i.e. charges recorded from the start of the communication and until the moment the charging information is sent to the served user), or as charging units.

When the call is released, the network shall send the recorded charges for the communication to the served user.

### 4.4 Charging information at the end of the communication (AOC-E)

When the AOC-E service is activated, the network shall provide the served user with charging information indicating the recorded charges for a communication when this communication is released.

### 4.5 Operational requirements

#### 4.5.1 Provision/withdrawal

The AOC services shall be provided to the served user after prior arrangement with the service provider or, as a service provider option, be generally available. Withdrawal of these services shall be made on the served user's request or for service provider reasons.

When available the AOC services shall be provided for all communications (permanent mode).

#### 4.5.2 Requirements on the originating network side

No specific requirements are needed in the network.

### 4.5.3 Requirements on the terminating network side

No specific requirements are needed in the network.

## 4.6 Coding requirements

The INFO method according to IETF RFC 6086 [4] with legacy INFO usage is needed in support of AOC-D.

The AOC XML schema is defined in annex D. The AOC XML schema shall be transported as a SIP MIME body. The MIME type for the AOC information is "application/vnd.etsi.aoc+xml" (see subclause 5.1). Any SIP message that transports a body with AOC information shall identify the payload as MIME type "application/vnd.etsi.aoc+xml", the MIME type associated with AOC information (see subclause 5.1), and shall identify in the "sv" or "schemaversion" parameter's value the versions of AOC XML Schema that can be used to validate the AOC information XML body (part). If both the "sv" and "schemaversion" parameters are present, then the P-CSCF shall ignore the value of the "schemaversion" parameter. The versions – of the MIME type associated with AOC information (see subclause 5.1) – indicated shall correspond with a value of the version attribute of the <schema> XML element of an AOC XML Schema (see e.g. annex D).

## 4.7 Signalling requirements

### 4.7.1 Activation/deactivation

The AOC service is activated at provisioning and deactivated at withdrawal.

#### 4.7.1A Registration/erasure

The AOC service requires no registration. Erasure is not applicable.

#### 4.7.1B Interrogation

Interrogation of AOC is not applicable.

### 4.7.2 Invocation and operation

#### 4.7.2.0 Introduction

Basic communication procedures according to 3GPP TS 24.229 [2] shall apply, with the additions outlined in the subclauses below.

#### 4.7.2.1 Actions at the served UE

The served UE shall support the INFO method according to IETF RFC 6086 [4] with legacy INFO usage and the AOC XML schema defined in annex D.

If methods or responses are received which contain AOC information, this information may be rendered to the user. The UE can render the AOC information e.g. as received or in a form as recalculated in the UE. The incremental cost is calculated as the difference between the subtotal charge of the currently received AOC information and the subtotal charge of the last received AOC information.

In addition to the procedures according to 3GPP TS 24.229 [2], the served UE shall include the Accept header field with:

- "application/vnd.etsi.aoc+xml", the MIME type associated with AOC information (see subclause 5.1), and indicate the versions of the AOC XML Schema it supports. The versions – of the MIME type associated with AOC information (see subclause 5.1) – indicated shall correspond with a value of the version attribute of the <schema> XML element of an AOC XML Schema (see e.g. annex D); and
- any other MIME type the served UE is willing and capable to accept.

## 4.7.2.2 Actions at the AS of the served user

### 4.7.2.2.0 General

The AS shall assume that the served user's UE supports version 1.0 of the MIME type associated with AOC information (see subclause 5.1), if support for the MIME type associated with AOC information in the Accept header is not indicated. The versions – of the MIME type associated with AOC information (see subclause 5.1) – indicated shall correspond with a value of the version attribute of the <schema> XML element of an AOC XML Schema (see e.g. Annex D).

When sending AOC information, the AS shall encode this information according to the XML-schema defined in annex D. In addition, for this MIME body the AS shall:

- set the Content-Type header to "vnd.etsi.aoc+xml", the MIME type associated with AOC information (see subclause 5.1), and shall include in its "sv" or "schemaversion" parameter's value the versions of AOC XML Schema that can be used to validate the AOC information XML body (part). If both the "sv" and "schemaversion" parameters are present, then the P-CSCF shall ignore the value of the "schemaversion" parameter. The versions – of the MIME type associated with AOC information (see subclause 5.1) – indicated shall correspond with a value of the version attribute of the <schema> XML element of an AOC XML Schema (see e.g. Annex D); and
- set the Content-Disposition to "render" with the "handling" parameter set to "optional".

In the case the AOC information is transported in a message that is forwarded by the AS that contains already a content body, the AS shall generate a multipart/mixed MIME body containing two sub-parts:

- one with the AOC information; the Content-Type and Content-Disposition of this sub-part should be coded as specified for non-multipart bodies;
- one with the received body; headers describing the content of the received SIP message (e.g. Content-type) should be moved into the headers of the this subpart.

In the case the AOC information is transported in a message that is forwarded by the AS, that contains already a content body and the served user's UE has not indicated support for multipart content, the AS shall forward the message unchanged.

NOTE: The above subclause ensures that a communication setup is not affected in case a terminal does not support multipart content.

### 4.7.2.2.1 Actions for AOC-S

#### 4.7.2.2.1.1 Served user is the originating user

When an INVITE request is received, and the served user is subscribed to AOC-S service, the AS shall either (network operator option) operate as a SIP proxy as specified in subclause 5.7.4 of 3GPP TS 24.229 [2] and in IETF RFC 3262 [5] and include the AOC information in the content body of a reliable 1xx provisional responses, or operate as a routing B2BUA as specified in subclause 5.7.5 of 3GPP TS 24.229 [2] and include the AOC information in the content body of a 200 (OK) response forwarded by the AS.

If the charging rates change during the communication, the AS shall send the AOC information to the UE of the served user in the content body of a mid-dialog request forwarded by the AS or an INFO request generated by the AS.

NOTE: If no charging information is available, then the AS can, as a network option, stop the communication establishment before the session is confirmed by sending a 504 (Server Time-out) response to the originating user and a BYE request to the terminating side. The BYE request contains a Reason header field with a reason value with the protocol set to "SIP" and the cause set to "504" and optionally a reason value with the protocol set to "Q.850" and the cause set to "31".

#### 4.7.2.2.1.2 Served user is the terminating user

The AS shall operate as a routing B2BUA as specified in subclause 5.7.5 of 3GPP TS 24.229 [2].

When an INVITE request is received, and the served user is subscribed to the AOC-S service, the AS shall include the AOC information in the content body in the INVITE request before sending the INVITE request to the terminating UE.

If the charging rates change during the communication, the AS shall send the AOC information to the UE of the served user in the content body of a mid-dialog request forwarded by the AS or an INFO request generated by the AS.

**NOTE:** If no charging information is available, then the AS can, as a network option, not forward the communication invitation and send a 504 (Server Time-out) response to the originating side.

#### 4.7.2.2.2 Actions for AOC-D

The AS shall operate as a routing B2BUA as specified in subclause 5.7.5 of 3GPP TS 24.229 [2].

The procedures for AOC-D service at the AS are the same for the originating and the terminating user.

If the user is subscribed to AOC-D service, the AS may provide charging information to the user at any moment during the active phase of the communication. When sending the charging information, the AS shall include the AOC information in the content body of a mid-dialog request or mid-dialog response forwarded by the AS to the served user or an INFO request to the served user generated by the AS. The supplied charging information shall be provided as a cumulative charge incurred so far for the communication (i.e. charges recorded from the start of the communication until the moment the charging information is sent to the served user).

When the communication is terminated, the AS shall include the recorded AOC information for the communication in the content body of either the BYE request or the final response to the BYE request sent to the served user. If the communication is free of charge, then the AS shall indicate the charged amount as zero in the AOC information.

#### 4.7.2.2.3 Actions for AOC-E

The AS shall operate as a SIP proxy as specified in subclause 5.7.4 of 3GPP TS 24.229 [2].

The procedures for AOC-E service at the AS are the same for the originating and the terminating user.

If the user is subscribed to AOC-E service, when the communication is terminated the AS shall include the recorded AOC information for the communication in the content body of either the BYE request or the final response to the BYE request sent to the served user. If the communication is free of charge, then the AS shall indicate the charged amount as zero in the AOC information.

## 4.8 Interaction with other services

### 4.8.1 Communication Waiting (CW)

No impact, i.e. neither service shall affect the operation of the other service.

### 4.8.2 Communication Hold (HOLD)

No impact, i.e. neither service shall affect the operation of the other service.

### 4.8.3 Terminating Identification Presentation (TIP)

No impact, i.e. neither service shall affect the operation of the other service.

### 4.8.4 Terminating Identification Restriction (TIR)

No impact, i.e. neither service shall affect the operation of the other service.

### 4.8.5 Originating Identification Presentation (OIP)

No impact, i.e. neither service shall affect the operation of the other service.

#### 4.8.6 Originating Identification Restriction (OIR)

No impact, i.e. neither service shall affect the operation of the other service.

#### 4.8.7 CONFerence calling (CONF)

No impact, i.e. neither service shall affect the operation of the other service.

NOTE: AOC information as result of a CONF invocation is out of scope the present document.

#### 4.8.8 Communication DIVersion services (CDIV)

No impact, i.e. neither service shall affect the operation of the other service.

#### 4.8.9 Advice Of Charge (AOC)

If the AOC-D and AOC-E services are activated for the same communication, at the end of the communication the network shall only send AOC-E type information.

#### 4.8.10 Completion of Communications to Busy Subscriber (CCBS) Completion of Communications by No Reply (CCNR)

No impact, i.e. neither service shall affect the operation of the other service.

#### 4.8.11 Malicious Communication IDentification (MCID)

No impact, i.e. neither service shall affect the operation of the other service.

#### 4.8.12 Anonymous Communication Rejection and Communication Barring (ACR/CB)

No impact, i.e. neither service shall affect the operation of the other service.

#### 4.8.13 Explicit Communication Transfer (ECT)

No impact, i.e. neither service shall affect the operation of the other service.

NOTE: AOC information as result of an ECT invocation is out of scope of the present document.

### 4.9 Interactions with other networks

Not applicable.

### 4.10 Parameter values (timers)

Not applicable.

## 5 Extensions within the present document

### 5.1 AOC information XML body

#### 5.1.1 General

This subclause contains the AOC information XML body in XML format. The AOC information XML shall be valid against the AOC XML schema defined in Annex D.

See subclause 5.1.2 for the associated MIME type definition.

#### 5.1.2 MIME type definition

##### 5.1.2.1 Introduction

This subclause defines the MIME type for "application/vnd.etsi.aoc+xml". An AOC information XML Document can be identified with this media type.

##### 5.1.2.2 Syntax

The following optional parameters are defined:

- "charset": the parameter has identical semantics to the charset parameter of the "application/xml" media type as specified in IETF RFC 3023 [8].
- "sv" or "schemaversion": the syntax for the "sv" or "schemaversion" parameter is specified in table 2:

**Table 2: Syntax of the "sv" or "schemaversion" parameter**

```
m-parameter      =/ ("sv" / "schemaversion") EQUAL LDQUOTE [ sv-value-list ] RDQUOTE
sv-value-list    = sv-value-range *( "," sv-value )
sv-value-range   = sv-value [ "-" sv-value ]
sv-value         = number / token
number           = 1*DIGIT [ "." 1*DIGIT ]
```

The BNF for m-parameter is taken from IETF RFC 3261 [7] and modified accordingly.

##### 5.1.2.3 Operation

The encoding considerations for "application/vnd.etsi.aoc+xml" are identical to those of "application/xml" as described in IETF RFC 3023 [8].

The "sv" or "schemaversion" parameter's value is used to indicate:

- the versions of the AOC information XML schema that can be used to validate the AOC information XML body (if the MIME type and parameter are present in the Content-Type header); or
- the accepted versions of the AOC information XML body (if the MIME type and parameter are present in the Accept header). If the "sv" or "schemaversion" parameter's value is empty, no versions of the of the AOC information XML schema are supported.

If the "sv" and "schemaversion" parameter are absent, it shall be assumed that version 1.0 of the XML Schema for the AOC information XML body is supported.

# Annex A (informative): Signalling flows

## A.1 Introduction

The service is divided into two aspects:

- a) Application Server gathers information: this is out of scope of the present document.
- b) User is provided the AOC Information.

## A.2 User originating AOC service

### A.2.1 AOC-S

#### A.2.1.1 AOC-S with AOC information in reliable 1xx responses

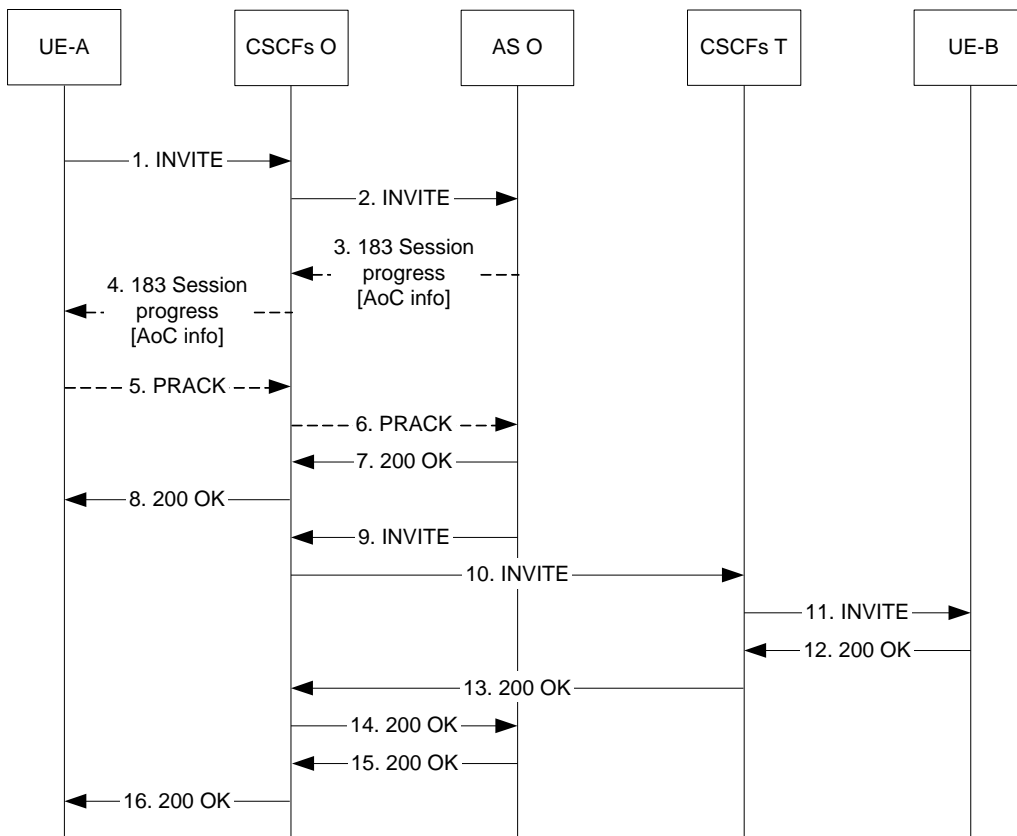

**Figure A.2.1.1: Charging info during session set-up (originating side)**

Figure A.2.1.1 shows one ordering of the messages. Message 3 and message 9 can be sent at the same moment.

#### General

The AOC information is provided for every communication. This is provisioned in the AS. The AOC information is sent to UE-A in a 183 (Session Progress) response.

**Call flows**

1 to 5 and 1 to 2 The communication is initiated by UE-A by sending an INVITE request. The Request URI will include the URI of UE-B. After IFC evaluation in the S-CSCF the INVITE request is routed to the Originating AS. The INVITE request will indicate support for 100rel extension.

3 to 8 The Originating AS sends the AOC information to UE-A in a reliable 183 (Session Progress) response.

9 to 11 The INVITE request is sent to UE-B.

12 to 16 The UE-B answers the communication. The 200 (OK) response is generated by UE-B.

**A.2.1.2 AOC-S with AOC information in a 200 (OK) response**

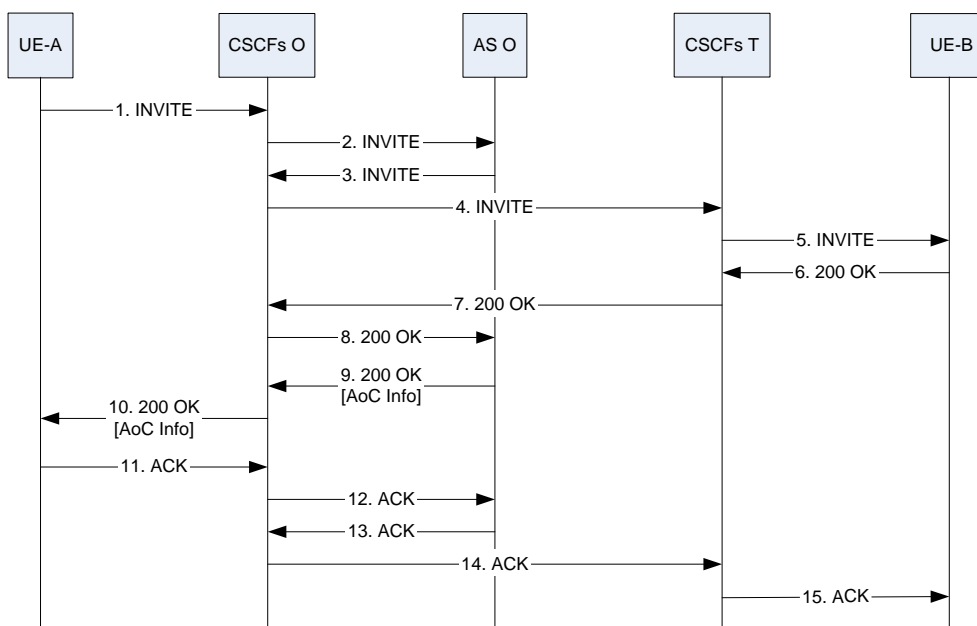

**Figure A.2.1.2: Charging info in 200 (OK) response during session set-up (originating side)**

Figure A.2.1.2 shows one ordering of the messages.

**General**

The AOC information is provided for every call. This is provisioned in the AS. The AOC information is sent to UE-A in 200 (OK) response (to INVITE request) after receiving a 200 (OK) response (to the INVITE request) from UE-B.

**Call flows**

1-5 The call is initiated by UE-A by sending an INVITE request. The Request URI will include the URI of UE-B. The INVITE request is routed via the Originating AS to UE-B.

6-10 UE-B answers the call. The 200 (OK) response is generated by UE-B. The Originating AS sends the AOC information to UE-A in this 200 (OK) response.

11-15 UE-A sends an ACK request to UE-B and the session is established.



### A.2.1.3 AOC-S with AOC information in INFO messages

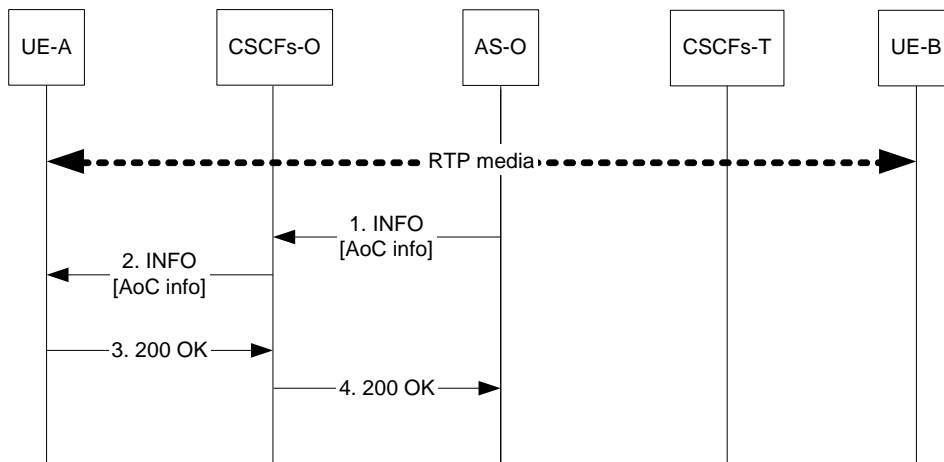

**Figure A.2.1.3: Charging info during the communication**

This can be a continuation of figures A.2.1.1 or A.2.1.2.

**General**

The AOC information is provided to the UE in the content body of a mid-dialog request forwarded by the AS or an INFO request generated by the AS, if the charging rates change during the communication.

**Call flow**

1-4. **When the charging rate changes, an INFO request** is send from the Originating AS to UE-A. The AOC information is included in the INFO request.

### A.2.2 AOC-D

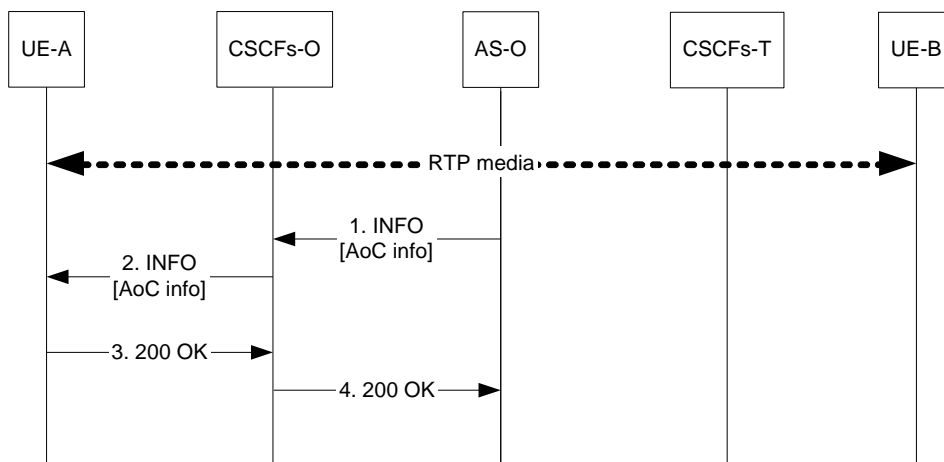

**Figure A.2.2.1: Charging info during the communication**

This can be a continuation of figures A.2.1.1 or A.2.1.2.

**General**

The AOC information is provided to the UE in the content body of a mid-dialog request or mid-dialog response forwarded by the originating AS, or an INFO message generated by the originating AS. The charging information indicates a cumulative charge incurred so far for the communication.

**Call flow**

1-4 In order to send an update on the cumulative charge incurred so far, an **INFO request** is send from the Originating AS to UE-A. The AOC information is included in the INFO request.A.2.3 AOC-E

**Calling party clears**

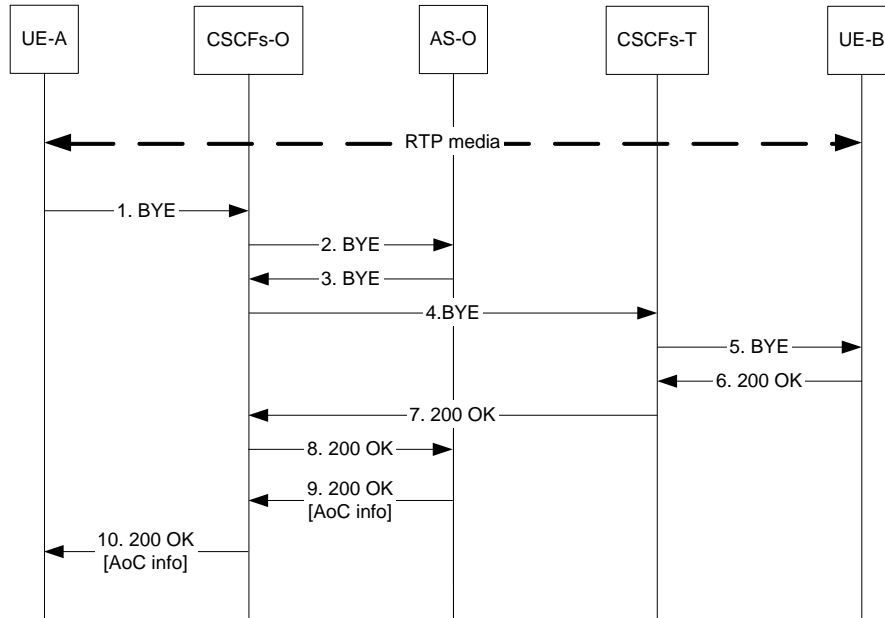

**Figure A.2.3.1: Calling party clears**

The AOC information is provided for every communication after the communication has finished. This is provisioned in the AS. The AOC information is sent to the terminal in a 200 (OK) response (to the BYE request), which is originated from UE-B.

**Call Flow**

The communication has been set up as a normal communication.

1-5 UE-A generates a BYE request to terminate the session, which is routed to UE-B.

6-10 UE-B sends a 200 (OK) response (to BYE request) towards UE-A. When the Originating AS receives the 200 (OK) response, it adds the AOC information to the 200 (OK) response (to the BYE request).

**Called party clears**

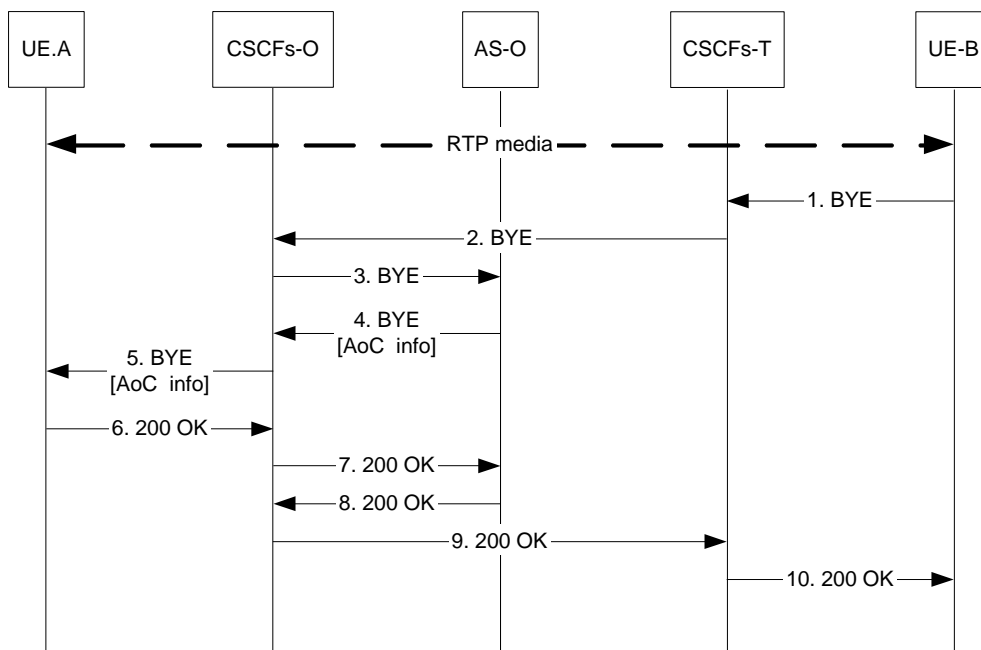

**Figure A.2.3.2: Called party clears**

The AOC information is provided for every communication after the communication has finished. This is provisioned in the AS. The charging info is sent to the terminal in a BYE request, which is originated from UE-B.

**Call Flow**

The communication has been set-up as a normal communication.

1-5 UE-B generates a BYE request to terminate the session, which is routed to the UE-A. When the Originating AS receives the BYE request, it adds the AOC information to the BYE request.

6-10 UE-A sends a 200 (OK) response (to the BYE request) towards UE-B.

## A.3 User terminating AOC service

### A.3.1 AOC-S

#### A.3.1.1 AOC-S with AOC information during session set-up

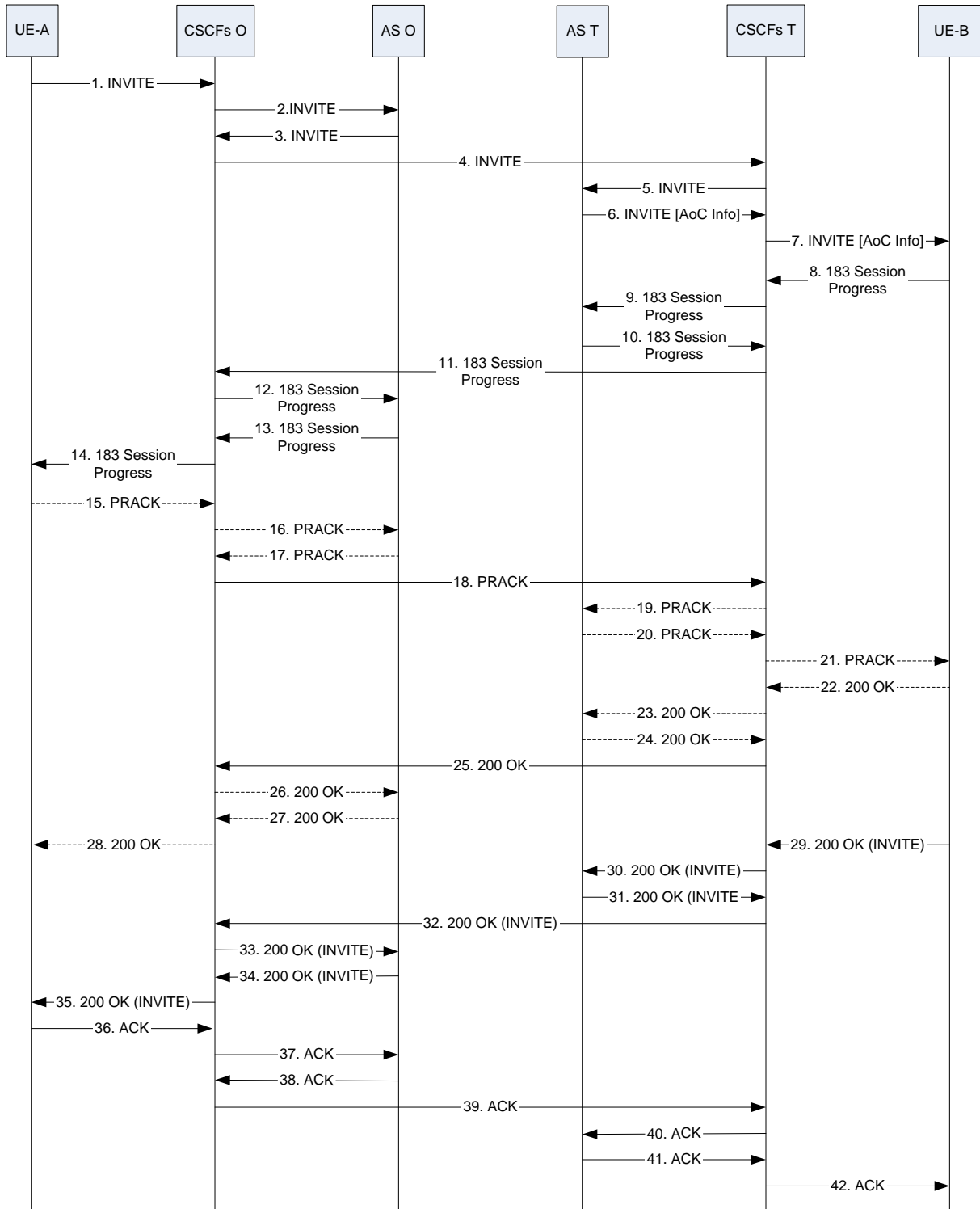

Figure A.3.1.1: Charging info during session set-up on the terminating side

**General**

The AOC information is provided for every call. This is provisioned in the AS. The AOC information is sent to the terminal in an INVITE request. Since this is a service that is charged an acknowledgement is required to ensure that the charging info is transferred.

**Call flows**

1-5 The call is initiated by UE-A by sending an INVITE request. The Request URI will include the URI of UE-B. The INVITE request is routed to the Originating AS and the Terminating AS. The INVITE request will indicate that 100rel extension is supported.

6-7 The Terminating AS will include the charging info in the INVITE request sent to the UE-B.

8-28 UE-B sends a reliable provisional response to indicate that INVITE request is being processed.

29-35 UE-B answers with a 200 (OK) response (to the INVITE request) and sends it to UE-A.

36-42 UE-A sends an ACK request to acknowledge the 200 (OK) response (to the INVITE request) and the session is established successfully.

**A.3.1.2 AOC-S with AOC information in INFO messages**

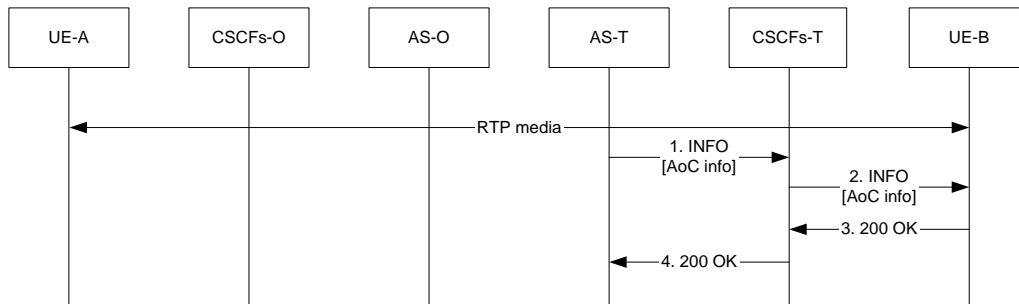

**Figure A.3.1.2: Charging info during the communication (terminating)**

This can be a continuation of figure A.3.1.1.

**General**

The AOC information is provided to the UE in the content body of a mid-dialog request forwarded by the AS or an INFO request generated by the AS, if the charging rates change during the communication.

**Call flows**

1-4. When the charging rate changes, an INFO request is send from the terminating AS to UE-B. The AOC information is included in the INFO request.

**A.3.2 AOC-D**

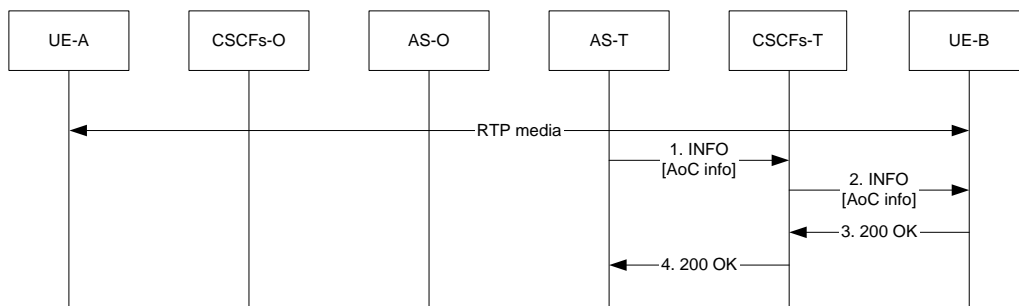

**Figure A.3.2.1: Charging info during the call (terminating)**

This can be a continuation of figure A.3.1.1.

**General**

The AOC information is provided to the UE in the content body of a mid-dialog request or mid-dialog response forwarded by the terminating AS, or an INFO message generated by the terminating AS. The charging information indicates a cumulative charge incurred so far for the communication.

**Call flows**

1-4 In order to send an update on the cumulative charge incurred so far, an INFO request is send from the terminating AS to UE-B. The AOC information is included in the INFO request.

**A.3.3 AOC-E**

**Calling party clears**

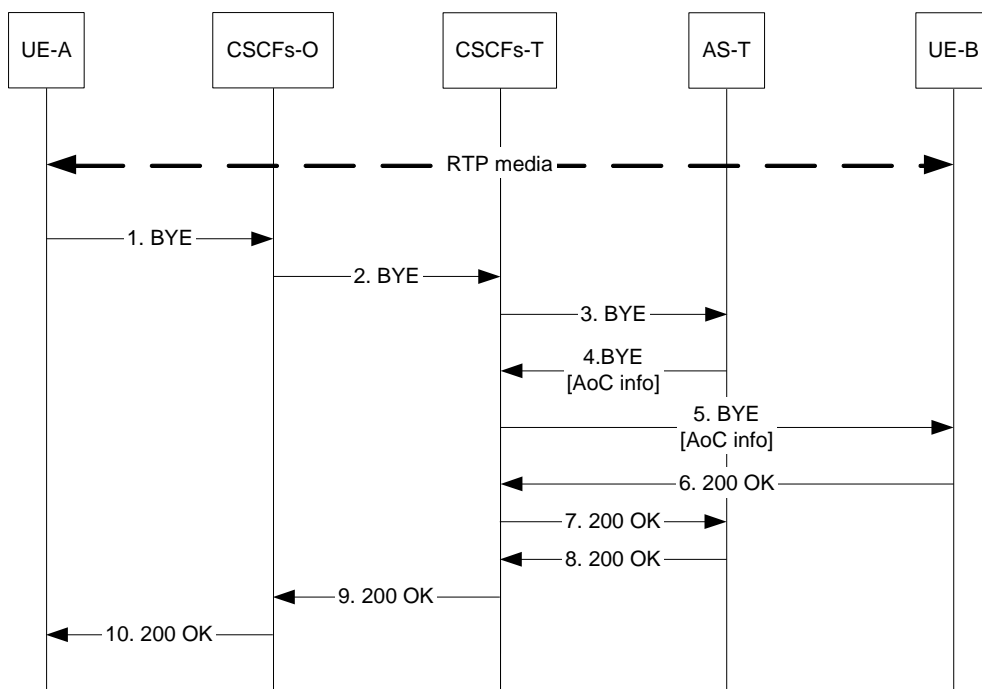

**Figure A.3.3.1: Calling party clears**

The AOC information is provided for every communication after the communication has finished. This is provisioned in the AS. The AOC information is sent to the terminating user in the BYE request which is originated from UE-A.

**Call Flow**

The communication has been set up as a normal communication.

1-5 UE-A generates a BYE request to terminate the session, which is routed to the UE-B. When the Terminating AS receives the BYE request, it adds the AOC information.

6-10 UE-B sends a 200 (OK) response towards UE-A.

**Called party clears**

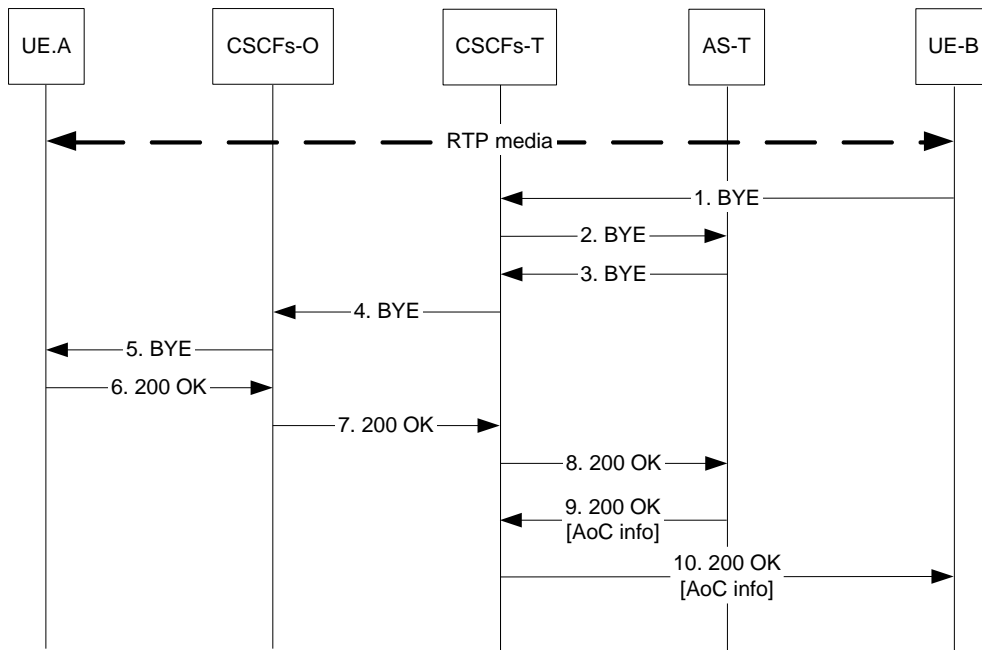

**Figure A.3.3.2: Called party clears**

The AOC information is provided for every communication after the communication has finished. This is provisioned in the AS. The charging info is sent to the terminating user in the 200 (OK) response, which is originated from UE-A.

**Call Flow**

The communication has been set-up as a normal communication.

1-5 UE-B generates a BYE request to terminate the session, which is routed to UE-A.

6-10 UE-A sends a 200 (OK) response towards UE-B. When the Terminating AS receives the 200 (OK) response, it adds the AOC information.

---

## Annex B (informative): Example of Filter Criteria

This annex provides an example of a filter criterion that triggers SIP requests that are subject to initial filter criteria evaluation.

An example of an IFC when the AOC service is active at the originating S-CSCF is:

- Method: INVITE.



---

## Annex C (normative): Charging Information Elements

### C.1 General

This annex describes the charging information to be provided to the served user. The AoC information model and UNI protocol mapping of the information elements is defined in 3GPP TS 32.280 [10].

---

### C.2 AOC-S

The AOC-S service provides tariff information at the start of the call or when tariff changes occur during the call.

#### C.2.1 Charged Items

AOC-S can provide a list of charged items.

Following charged items are thought applicable:

- basic communication;
- communication attempt;
- communication setup;
- operation of supplementary services.

##### C.2.1.1 Charged Item: basic communication

This expresses the rate for the basic communication.

The rate shall be expressed as:

- price per time unit and unit time (see subclause C.2.2.1); or
- free of charge (see subclause C.2.2.2); or
- flat rate (see subclause C.2.2.3); or
- not available (see subclause C.2.2.6).

##### C.2.1.2 Charged Item: communication attempt

This expresses the cost of a communication attempt.

The cost shall be expressed as:

- free of charge (see subclause C.2.2.2); or
- flat rate (see subclause C.2.2.3); or
- not available (see subclause C.2.2.6).

##### C.2.1.3 Charged Item: communication setup

This expresses the cost of a communication setup.

The cost shall be expressed as:

- free of charge (see subclause C.2.2.2); or
- flat rate (see subclause C.2.2.3); or
- not available (see subclause C.2.2.6).

#### C.2.1.4 Charged Item: operation of services

This expresses the cost induced by the execution of services.

The cost shall be expressed as:

- price per time unit and unit time (see subclause C.2.2.1); or
- free of charge (see subclause C.2.2.2); or
- flat rate (see subclause C.2.2.3); or
- not available (see subclause C.2.2.6).

#### C.2.1.5 Void

### C.2.2 Expressing Charging Rates

AOC-S can express charging rate as:

- price per time unit and unit time (see subclause C.2.2.1); or
- free of charge (see subclause C.2.2.2); or
- flat rate (see subclause C.2.2.3); or
- charging unit (see subclause C.2.2.5); or
- not available (see subclause C.2.2.6).

#### C.2.2.1 Duration charge: Price per time unit, and unit time

Duration charge shall contain the following elements:

- currency identifier (see subclause C.5.4); and
- currency amount (see subclause C.5.5); and
- length of time unit (see subclause C.5.6); and
- type of charging (see subclause C.5.8).

and additionally it may contain the following element:

- granularity (see subclause C.5.7).

#### C.2.2.2 Specific: free of charge

This rate represents a free charge.

#### C.2.2.3 Specific: flat rate

It shall be expressed as:

- currency identifier (see subclause C.5.4);
- currency amount (see subclause C.5.5).

#### C.2.2.4 Void

#### C.2.2.5 Charging unit

Charging unit shall contain the following elements:

- currency identifier (see subclause C.5.4); and
- currency amount (see subclause C.5.5).

#### C.2.2.6 Not available

Expresses that the charging information is not available.

---

### C.3 AOC-D

The AOC-D service provides information about the recorded charges during the active phase of a call.

The information shall contain the following elements:

- type of charging information (see subclause C.3.1); and
- recorded charges (see subclause C.3.2).

#### C.3.1 Type of charging information

Type of charging information shall have one of the following values:

- subtotal charges; or
- total charges.

#### C.3.2 Recorded charges

Recorded charges shall be expressed as one of the following elements:

- recorded number of currency units or charging units (see subclause C.5.9); or
- free of charge; or
- not available.

#### C.3.3 Void

---

### C.4 AOC-E

The AOC-E service provides information about the recorded charges for a call when it is terminated.

The information consists of:

- recorded charges (see subclause C.3.2)

## C.4.1 Void

---

# C.5 Common types/information elements

## C.5.1 Time unit

Time unit shall be an integer value.

## C.5.2 Decimal

Decimal shall be a decimal value.

## C.5.3 Scale

The scale of time units shall have one of the following values:

- 0,01 s;
- 0,1 s;
- 1 s;
- 10 s;
- 1 min;
- 1 hour; or
- 24 hours.

## C.5.4 Currency identifier

It shall be a string specifying the used currency or a charging unit identifier.

## C.5.5 Currency amount

It shall be expressed as the value of decimal (see subclause C.5.2).

## C.5.6 Length of time unit

It shall be expressed as value of integer  $\times$  scale:

- time unit (see subclause C.5.1); and
- scale (see subclause C.5.3).

## C.5.7 Granularity

This specifies the time unit applied for calculation of charges by the network.

It shall be expressed as value of integer  $\times$  scale:

- time unit (see subclause C.5.1); and
- scale (see subclause C.5.3).

## C.5.8 Type of charging

Type of charging shall have one of the values of "step function" or "continuous".

## C.5.9 Recorded number of currency units

It shall be expressed as:

- currency identifier (see subclause C.5.4);
- currency amount (see subclause C.5.5).

---

# C.6 Charge Advice Information (CAI)

## C.6.1 General

The network may provide the necessary Charge Advice Information (CAI) at the charging point on a per call basis. The UE may support CAI and may use it to compute the AOC value for the relevant call.

The CAI shall contain the elements as defined in 3GPP TS 22.024 [11].

## C.6.2 CAI items

### C.6.2.1 General

CAI elements are mapped to the AOC information as described in 3GPP TS 32.280 [10].

### C.6.2.2 Initial cost

It shall be expressed as:

- e4 - Unit increment defines the number of units to be incremented on receipt of the message containing the CAI elements and shall be mapped to the "Currency amount" element (see subclause C.5.5); and
- e7 - Initial secs/t interval defines the initial time interval for unitization and shall be expressed as "Length of time unit" element (see subclause C.5.6); and
- e3 - Scaling Factor defines the scaling factor to convert from LPLMN units to HPLMN units and shall be mapped to the "Scale" element (see subclause C.5.3).

### C.6.2.3 Time related

It shall be expressed as:

- e1 - Units per interval defines the number of units incremented per interval and shall be mapped to the "Currency amount" element (see subclause C.5.5); and
- e2 - Seconds/time interval defines the time interval for unitization and shall be mapped to the "Length of time unit" element (see subclause C.5.6); and
- e3 - Scaling Factor defines the scaling factor to convert from LPLMN units to HPLMN units and shall be mapped to the "Scale" element (see subclause C.5.3).

### C.6.2.4 Volume related

It shall be expressed as:

- e5 - Units per data interval is used for volume related AOC information and shall be mapped to the "Currency amount" element (see subclause C.5.5); and
- e6 - Segments/data interval is used for volume related AOC information and shall be mapped to the "Length of time unit" element (see subclause C.5.6); and
- e3 - Scaling Factor defines the scaling factor to convert from LPLMN units to HPLMN units and shall be mapped to the "Scale" element (see subclause C.5.3).

# Annex D (normative): AOC XML Schema, version 1.0:

## D.1 Basic XML schema

This annex defines the XML Schema to be used for providing the charging information described in annex C in the SIP methods to the served user. As defined in 3GPP TS 32.280 [10], the information elements "special-arrangement", "special-code" and "billing-id" are not applicable.

The application/vnd.etsi.aoc+xml MIME type used to provide the charging information requested by the served user shall be coded as following described:

```
<?xml version="1.0" encoding="UTF-8"?>
<xs:schema targetNamespace="http://uri.etsi.org/ngn/params/xml/simservs/aoc"
xmlns="http://uri.etsi.org/ngn/params/xml/simservs/aoc" xmlns:xs="http://www.w3.org/2001/XMLSchema"
elementFormDefault="qualified" attributeFormDefault="unqualified" version="1.0">

  <xs:import namespace="http://www.w3.org/XML/1998/namespace"
schemaLocation="http://www.w3.org/2001/xml.xsd"/>
  <xs:annotation>
    <xs:documentation xml:lang="en">
      XML Schema Definition to the charging information related to the Advice of Charge service.
    </xs:documentation>
  </xs:annotation>

  <xs:element name="aoc" type="aocType"/>

  <xs:complexType name="aocType">
    <xs:sequence>
      <xs:element name="aoc-s" type="aoc-sType" minOccurs="0"/>
      <xs:element name="aoc-d" type="aoc-dType" minOccurs="0"/>
      <xs:element name="aoc-e" type="aoc-eType" minOccurs="0"/>
      <xs:any namespace="##other" processContents="lax" minOccurs="0" maxOccurs="unbounded"/>
    </xs:sequence>
    <xs:anyAttribute namespace="##any" processContents="lax"/>
  </xs:complexType>

  <!-- xs:sequence is changed to xs:choice -->
  <xs:complexType name="aoc-sType">
    <xs:choice>
      <xs:element name="special-arrangement" type="xs:token"/>
      <xs:element name="charged-items" type="charged-itemsType"/>
      <xs:any namespace="##other" processContents="lax" minOccurs="0"
maxOccurs="unbounded"/>
    </xs:choice>
    <xs:anyAttribute namespace="##any" processContents="lax"/>
  </xs:complexType>

  <xs:complexType name="aoc-dType">
    <xs:sequence>
      <xs:element name="charging-info" type="charging-infoType" />
      <xs:element name="recorded-charges" type="recorded-chargesType" />
      <xs:element name="billing-id" type="billind-idType" minOccurs="0" />
      <xs:any namespace="##other" processContents="lax" minOccurs="0"
maxOccurs="unbounded"/>
    </xs:sequence>
    <xs:anyAttribute namespace="##any" processContents="lax"/>
  </xs:complexType>

  <xs:complexType name="aoc-eType">
    <xs:sequence>
      <xs:element name="recorded-charges" type="recorded-chargesType" />
      <xs:element name="billing-id" type="billind-idType" minOccurs="0" />
      <xs:any namespace="##other" processContents="lax" minOccurs="0"
maxOccurs="unbounded"/>
    </xs:sequence>
    <xs:anyAttribute namespace="##any" processContents="lax"/>
  </xs:complexType>
```

```

<xs:complexType name="charged-itemsType">
  <xs:sequence>
    <xs:element name="basic" type="basicType" minOccurs="0" />
    <xs:element name="communication-attempt" type="communication-attemptType"
minOccurs="0" />
    <xs:element name="communication-setup" type="communication-setupType"
minOccurs="0" />
    <xs:element name="services" type="servicesType" minOccurs="0" />
    <xs:any namespace="##other" processContents="lax" minOccurs="0"
maxOccurs="unbounded" />
  </xs:sequence>
  <xs:anyAttribute namespace="##any" processContents="lax" />
</xs:complexType>

<xs:complexType name="basicType">
  <xs:sequence>
    <xs:element name="price-time" type="price-timeType" minOccurs="0"
maxOccurs="unbounded" />
    <xs:element name="flat-rate" type="currency-id-amountType" minOccurs="0" />
    <xs:element name="free-charge" type="emptyType" minOccurs="0" />
    <xs:element name="special-code" type="xs:token" minOccurs="0" />
    <xs:element name="not-available" type="emptyType" minOccurs="0" />
  </xs:sequence>
</xs:complexType>

<xs:complexType name="communication-attemptType">
  <xs:sequence>
    <xs:element name="flat-rate" type="currency-id-amountType" minOccurs="0" />
    <xs:element name="free-charge" type="emptyType" minOccurs="0" />
    <xs:element name="special-code" type="xs:token" minOccurs="0" />
    <xs:element name="not-available" type="emptyType" minOccurs="0" />
  </xs:sequence>
</xs:complexType>

<xs:complexType name="communication-setupType">
  <xs:sequence>
    <xs:element name="flat-rate" type="currency-id-amountType" minOccurs="0" />
    <xs:element name="free-charge" type="emptyType" minOccurs="0" />
    <xs:element name="special-code" type="xs:token" minOccurs="0" />
    <xs:element name="not-available" type="emptyType" minOccurs="0" />
  </xs:sequence>
</xs:complexType>

<xs:complexType name="servicesType">
  <xs:sequence>
    <xs:element name="price-time" type="price-timeType" minOccurs="0" />
    <xs:element name="flat-rate" type="currency-id-amountType" minOccurs="0" />
    <xs:element name="free-charge" type="emptyType" minOccurs="0" />
    <xs:element name="special-code" type="xs:token" minOccurs="0" />
    <xs:element name="not-available" type="emptyType" minOccurs="0" />
  </xs:sequence>
</xs:complexType>

<!-- length-time-unit: type="timeType" (another possibility is to keep length-time-unit with
type="xs:duration")
granularity: type="timeType" (another possibility is type="xs:duration")
(xs:duration: the minimum resolution is second)
-->
<xs:complexType name="price-timeType">
  <xs:sequence>
    <xs:element name="currency-id" type="xs:token" minOccurs="0" />
    <!-- The currency-id shall be coded according to ISO 4217 [3] or set to the value
"UNIT" for the sending of charging units. -->
    <xs:element name="currency-amount" type="xs:decimal" minOccurs="0" />
    <xs:element name="length-time-unit" type="timeType" minOccurs="0" />
    <xs:element name="charging-type" type="charging-typeType" minOccurs="0" />
    <xs:element name="granularity" type="timeType" minOccurs="0" />
  </xs:sequence>
</xs:complexType>

<xs:complexType name="currency-id-amountType">
  <xs:sequence>
    <xs:element name="currency-id" type="xs:token" minOccurs="0" />
    <!-- The currency-id shall be coded according to ISO 4217 [3] or set to the value
"UNIT" for the sending of charging units. -->
    <xs:element name="currency-amount" type="xs:decimal" minOccurs="0" />
  </xs:sequence>
</xs:complexType>

```



```

<!-- timeType is represented with time-unit (unsigned int) * scale (enum) -->
<xs:complexType name="timeType">
  <xs:sequence>
    <xs:element name="time-unit" type="xs:unsignedInt"/>
    <xs:element name="scale" type="scaleType"/>
  </xs:sequence>
</xs:complexType>

<xs:simpleType name="scaleType">
  <xs:restriction base="xs:token">
    <xs:enumeration value="one-hundreth-second"/>
    <xs:enumeration value="one-tenth-second"/>
    <xs:enumeration value="one-second"/>
    <xs:enumeration value="ten-seconds"/>
    <xs:enumeration value="one-minute"/>
    <xs:enumeration value="one-hour"/>
    <xs:enumeration value="twenty-four-hours"/>
  </xs:restriction>
</xs:simpleType>
<!-- end of timeType definition -->

<xs:complexType name="emptyType">
  <xs:complexContent>
    <xs:restriction base="xs:anyType"/>
  </xs:complexContent>
</xs:complexType>

<!-- simplified -->
<xs:simpleType name="charging-infoType">
  <xs:restriction base="xs:token">
    <xs:enumeration value="total" />
    <xs:enumeration value="subtotal" />
  </xs:restriction>
</xs:simpleType>

<!-- xs:sequence is changed to xs:choice -->
<xs:complexType name="recorded-chargesType">
  <xs:choice>
    <xs:element name="recorded-currency-units" type="currency-id-amountType"/>
    <xs:element name="free-charge" type="emptyType"/>
    <xs:element name="not-available" type="emptyType"/>
  </xs:choice>
</xs:complexType>

<xs:simpleType name="billind-idType">
  <xs:restriction base="xs:string">
    <xs:enumeration value="normal-charging"/>
    <xs:enumeration value="reverse-charging"/>
    <xs:enumeration value="credit-card"/>
    <xs:enumeration value="cfu"/>
    <xs:enumeration value="cfb"/>
    <xs:enumeration value="cfnr"/>
    <xs:enumeration value="cd"/>
    <xs:enumeration value="ct"/>
  </xs:restriction>
</xs:simpleType>

<xs:simpleType name="charging-typeType">
  <xs:restriction base="xs:string">
    <xs:enumeration value="step-functon" />
    <xs:enumeration value="continuous" />
  </xs:restriction>
</xs:simpleType>
</xs:schema>

```

---

## D.2 Extensions

```

<?xml version="1.0" encoding="UTF-8"?>
<xs:schema xmlns:xs="http://www.w3.org/2001/XMLSchema"
  xmlns:aocExt="urn:3gpp:ns:aocExt:1.0"
  targetNamespace="urn:3gpp:ns:aocExt:1.0"
  xmlns:origNS="http://uri.etsi.org/ngn/params/xml/simservs/aoc"
  elementFormDefault="qualified"

```

```

    attributeFormDefault="unqualified"
  >

  <xs:import namespace="http://uri.etsi.org/ngn/params/xml/simservs/aoc" />

  <!-- the element cai is inserted in aocType in place of the <xs:any namespace="##other"
  processContents="lax" minOccurs="0" maxOccurs="unbounded"/>particle -->
  <xs:element name="cai" type="aocExt:caiType"/>

  <xs:complexType name="caiType">
    <xs:sequence>
      <xs:element name="initial-cost" type="origNS:price-timeType" minOccurs="0" />
      <xs:element name="time-related" type="origNS:price-timeType" minOccurs="0" />
      <xs:element name="volume-related" type="aocExt:recorded-chargesExtType" minOccurs="0" />
      <xs:element name="anyExt" type="aocExt:anyExtType" minOccurs="0" />
      <xs:any namespace="##other" processContents="lax" minOccurs="0" maxOccurs="unbounded"/>
    </xs:sequence>
  </xs:complexType>

  <xs:complexType name="recorded-chargesExtType">
    <xs:choice>
      <xs:sequence>
        <xs:element name="recorded-currency-units" type="origNS:currency-id-amountType"/>
        <xs:element name="length-time-unit" type="origNS:timeType"/>
        <xs:element name="granularity" type="origNS:timeType"/>
        <xs:element name="anyExt" type="aocExt:anyExtType" minOccurs="0" />
        <xs:any namespace="##other" processContents="lax" minOccurs="0" maxOccurs="unbounded"/>
      </xs:sequence>
      <xs:element name="free-charge" type="origNS:emptyType"/>
      <xs:element name="not-available" type="origNS:emptyType"/>
      <xs:element name="anyExt" type="aocExt:anyExtType" minOccurs="0" />
      <xs:any namespace="##other" processContents="lax" minOccurs="0" maxOccurs="unbounded"/>
    </xs:choice>
  </xs:complexType>

  <xs:complexType name="anyExtType">
    <xs:sequence>
      <xs:any namespace="##any" processContents="lax" minOccurs="0" maxOccurs="unbounded"/>
    </xs:sequence>
  </xs:complexType>

</xs:schema>

```

---

## Annex E (informative): IANA Registration templates

### E.1 IANA registry for Application Media Types

#### E.1.1 IANA Registration template for application/vnd.etsi.aoc+xml

NOTE: IETF RFC 4288 [9], section 9, states the process that applies in case of changes to the registry of media types. Any future changes to the format or to annex E.1.1 would invoke this procedure.

MIME media type name:

application

MIME subtype name:

vnd.etsi.aoc+xml

Required parameters:

None

Optional parameters:

"charset" the parameter has identical semantics to the charset parameter of the "application/xml" media type as specified in IETF RFC 3023 [8].

"sv" or "schemaversion" the parameter's value is used to indicate:

- the versions of the SIP AOC information XML schema that can be used to validate the AOC information XML body (if the MIME type and parameter are present in the Content-Type header field) or
- the accepted versions of the AOC information XML body (if the MIME type and parameter are present in the Accept header field).

If the "sv" and "schemaversion" parameter are absent, it shall be assumed that version 1.0 of the AOC information XML body is supported.

Encoding considerations:

Same as encoding considerations of application/xml as specified in IETF RFC 3023 [8]

Security considerations:

Same as general security considerations for application/xml as specified in section 10 of IETF RFC 3023 [8].

In addition, this content type provides a format for exchanging information in SIP, so the security considerations from IETF RFC 3261 [7] apply.

Interoperability considerations:

Same as Interoperability considerations as specified in section 3.1 of IETF RFC 3023 [8].

If both "sv" and "schemaversion" are specified, then the value of "schemaversion" MUST be ignored

Published specification:

3GPP TS 24.647: "Advice Of Charge (AOC) using IP Multimedia (IM) Core Network (CN) subsystem", as published in subclause E.1.1, version 8.2.0.

Available via <<http://www.3gpp.org/specs/numbering.htm>>.

Applications which use this media:

Applications that use the 3GPP IP multimedia (IM) Core Network (CN) subsystem as defined by 3GPP.

Intended usage:

COMMON

Additional information :

1. Magic number(s) : none
2. File extension(s) : none
3. Macintosh file type code : none
4. Object Identifiers: none

## Annex F (informative): Change history

Change history								
Date	TSG #	TSG Doc.	CR	Rev	Subject/Comment	Old	New	
2007-03					Publication as <b>ETSI TS 183 047</b>		2.1.1	
2007-12					Conversion to <b>3GPP TS 24.447</b>		2.1.2	
2007-12					Technically identical copy as <b>3GPP TS 24.647</b> for further development		2.1.3	
2008-02					Implemented C1-080093		2.2.0	
2008-04					Implemented C1-081115		2.3.0	
2008-05					Implemented C1-081836		2.4.0	
2008-07					Implemented C1-082297 from CT1#54		2.5.0	
2008-08					Implemented C1-082956 from CT1#55 Sent to CT-41 plenary for approval.		2.6.0	
2008-09	CT#41	CP-080512			Created version 8.0.0 after approval in CT-41	2.6.0	8.0.0	
2008-12	CT#42	CP-080865	0001	1	Registration of MIME type with IANA	8.0.0	8.1.0	
2009-09	CT#45	CP-090665	0003	2	Aligning IANA registration of MIME type "application/vnd.etsi.aoc+xml"	8.1.0	8.2.0	
2009-12	CT#46	CP-090920	0008	2	Correction of AOC mandatory behaviour	8.2.0	9.0.0	
2010-03	CT#47	CP-100121	0010		AoC: ABNF correction	9.0.0	9.1.0	
2010-09	CT#49	CP-100516	0016	2	Modification of AoC UNI Protocol Mapping	9.1.0	10.0.0	
2010-12	CT#50	CP-100756	0017	2	Addition of Charge Advice Information (CAI),	10.0.0	10.1.0	
2011-06	CT#52	CP-110460	0022	1	Incremental cost information in AOC	10.1.0	10.2.0	
2011-09	CT#53	CP-110693	0023	1	Replace of obsolete INFO RFC with replacement RFC	10.2.0	11.0.0	
2011-12	CT#54	CP-110881	0027	2	Correction on usage of AOC-S and AOC-D	11.0.0	11.1.0	