

3GPP TS 24.504 V8.18.0 (2013-09)

Technical Specification

**3rd Generation Partnership Project;
Technical Specification Group Core Network and Terminals;
Telecommunications and Internet converged Services and
Protocols for Advanced Networking (TISPAN);
PSTN/ISDN simulation services:
Communication Diversion (CDIV);
Protocol specification
(Release 8)**



The present document has been developed within the 3rd Generation Partnership Project (3GPPTM) and may be further elaborated for the purposes of 3GPP.

The present document has not been subject to any approval process by the 3GPP Organizational Partners and shall not be implemented. This Specification is provided for future development work within 3GPP only. The Organizational Partners accept no liability for any use of this Specification. Specifications and reports for implementation of the 3GPPTM system should be obtained via the 3GPP Organizational Partners' Publications Offices.

Keywords

CDIV, supplementary services

3GPP

Postal address

3GPP support office address

650 Route des Lucioles - Sophia Antipolis
Valbonne - FRANCE
Tel.: +33 4 92 94 42 00 Fax: +33 4 93 65 47 16

Internet

<http://www.3gpp.org>

Copyright Notification

No part may be reproduced except as authorized by written permission.
The copyright and the foregoing restriction extend to reproduction in all media.

© 2013, 3GPP Organizational Partners (ARIB, ATIS, CCSA, ETSI, TTA, TTC).
All rights reserved.

UMTS™ is a Trade Mark of ETSI registered for the benefit of its members
3GPP™ is a Trade Mark of ETSI registered for the benefit of its Members and of the 3GPP Organizational Partners
LTE™ is a Trade Mark of ETSI currently being registered for the benefit of its Members and of the 3GPP Organizational Partners
GSM® and the GSM logo are registered and owned by the GSM Association

Contents

Foreword	6
1 Scope	7
2 References.....	7
2.1 Normative references.....	7
3 Definitions and abbreviations	9
3.1 Definitions	9
3.2 Abbreviations.....	9
4 Communications Diversion (CDIV)	10
4.1 Introduction	10
4.2 Description.....	10
4.2.1 General description	10
4.3 Operational requirements	14
4.3.1 Provision/withdrawal.....	14
4.3.2 Requirements on the originating network side.....	15
4.3.3 Requirements in the network.....	15
4.4 Coding requirements	15
4.4.1 SIP-Messages.....	16
4.4.1.1 SIP messages for redirection.....	16
4.4.1.2 SIP messages for CDIVN	16
4.4.2 Parameters	16
4.5 Signalling requirements	17
4.5.0 General.....	17
4.5.1 Activation/deactivation	17
4.5.1a Registration/erasure	17
4.5.1b Interrogation.....	17
4.5.2 Invocation and operation.....	17
4.5.2.1 Actions at the originating UA	17
4.5.2.2 Actions at the originating P-CSCF	17
4.5.2.3 Actions at the originating S-CSCF	17
4.5.2.4 Actions at the diverting S-CSCF	18
4.5.2.5 Actions at the diverted to S-CSCF.....	18
4.5.2.6 Actions at the AS of the diverting User	18
4.5.2.6.1 Checking of the diversion limits	18
4.5.2.6.2 Setting of the diversion parameters by the AS.....	18
4.5.2.6.3 Diversion procedures at the diverting AS.....	21
4.5.2.6.4 Notification procedures of the originating user (Subscription Option)	23
4.5.2.6.5 Indication of communication diversion to the diverting user /CDIV Notification_(subscription option).....	24
4.5.2.6.6 not reachable indication	26
4.5.2.7 Actions at the AS of the diverted to user.....	26
4.5.2.8 Void	26
4.5.2.9 Actions at the incoming I-CSCF	26
4.5.2.10 Actions at the outgoing IBCF	26
4.5.2.11 Actions at the incoming IBCF	26
4.5.2.12 Actions at the BGCF	27
4.5.2.13 Actions at the MGCF	27
4.5.2.14 Actions at the destination P-CSCF	27
4.5.2.15 Actions at the diverted to UA	27
4.5.2.16 Actions at the diverting UA	27
4.6 Interaction with other services	27
4.6.1 Communication Hold (HOLD)	27
4.6.2 Terminating Identification Presentation (TIP)	27
4.6.3 Terminating Identification Restriction (TIR)	27
4.6.4 Originating Identification Presentation (OIP)	27
4.6.5 Originating Identification Restriction (OIR)	28

4.6.6	Conference calling (CONF)	28
4.6.7	Communication Diversion Services (CDIV).....	28
4.6.8	Malicious Communication Identification (MCID).....	28
4.6.9	Anonymous Communication Rejection and Communication Barring (ACR/CB).....	28
4.6.10	Explicit Communication Transfer (ECT).....	28
4.6.10.1	Actions at the diverting AS	28
4.6.10.1.1	Determine whether ECT is applied to the diverted communication	28
4.6.10.1.2	Handling of transfer requests.....	28
4.6.10.1.3	Actions when CDIV is invoked again by the transferred communication	29
4.7	Interworking with other networks	29
4.7.1	Interworking with PSTN/ISDN	29
4.7.1.1	Interworking at the O-MGCF	29
4.7.1.1.1	Void	33
4.7.1.1.2	Call forwarding within the ISUP Network appeared	33
4.7.1.2	Interworking at the I-MGCF	35
4.7.2	Interworking with PSTN/ISDN Emulation.....	40
4.7.3	Interworking with external IP networks	40
4.8	Parameter values (timers).....	40
4.8.1	No reply timer.....	40
4.8.2	CDIVN Buffer Timer	40
4.8.3	CDIV Indication Timer	41
4.9	Service Configuration for redirection services.....	41
4.9.1	Structure of the XML Document.....	41
4.9.1.1	Communication Diversion Element	41
4.9.1.1A	NoReplyTimer.....	42
4.9.1.2	Communication Diversion Rules	42
4.9.1.3	Communication Diversion Rule Conditions	42
4.9.1.4	Communication Diversion Rule Actions	43
4.9.2	XML Schema	44
4.10	Service Configuration of Communication Diversion Notification	45
4.10.1	Structure of the XML Document.....	45
4.10.1.1	Communication Diversion Information	46
4.10.1.1.1	Communication Diversion Subscription Information	46
4.10.1.1.2	Communication Diversion Notification Information	47
4.10.2	XML Schema	48
Annex A (informative): Signalling Flows.....		52
A.1	Normal cases	52
A.1.1	Communication Forwarding unconditional	52
A.1.2	Communication Deflection	54
A.1.3	Communication Forwarding on non Reply	56
A.1.4	Communication Forwarding on Busy	60
A.1.5	Communication Forwarding Not Logged-in (CFNL).....	62
A.1.6	Communication Diversion Notification (CDIVN)	63
A.2	Interworking.....	65
A.2.1	Communication Forwarding unconditional	65
A.2.2	Communication Deflection	66

Annex B (informative): Example of filter criteria.....67

Annex C (informative): Coding considerations.....68

Annex D (informative): Bibliography69

Annex E (normative): Communication Diversion Notification XML body.....70

E.1 General.....70

E.2 Document Type Definition70

E.3 XML Schema description70

E.4 MIME type definition.....70

E.4.1 Introduction70

E.4.2 Syntax.....70

E.4.3 Operation.....70

E.5 IANA Registration70

Annex F (informative): Change history.....72

Foreword

This Technical Specification (TS) was been produced by ETSI Technical Committee Telecommunications and Internet converged Services and Protocols for Advanced Networking (TISPAN) and originally published as ETSI TS 183 004 [19]. It was transferred to the 3rd Generation Partnership Project (3GPP) in in January 2008.

The contents of the present document are subject to continuing work within the TSG and may change following formal TSG approval. Should the TSG modify the contents of the present document, it will be re-released by the TSG with an identifying change of release date and an increase in version number as follows:

Version x.y.z

where:

- x the first digit:
 - 1 presented to TSG for information;
 - 2 presented to TSG for approval;
 - 3 or greater indicates TSG approved document under change control.
- y the second digit is incremented for all changes of substance, i.e. technical enhancements, corrections, updates, etc.
- z the third digit is incremented when editorial only changes have been incorporated in the document.

1 Scope

The present document specifies the, stage three, Protocol Description of the Communications Diversion (CDIV) services, based on stage one and two of the ISDN Communication diversion supplementary services. Within the Next Generation Network (NGN) the stage 3 description is specified using the IP-Multimedia Communication Control Protocol based on Session Initiation Protocol (SIP) and Session Description Protocol (SDP).

In addition, a service "Communication Diversion Notification" (CDIVN) to the CDIV PSTN/ISDN simulation services is described in the present document.

2 References

The following documents contain provisions which, through reference in this text, constitute provisions of the present document.

- References are either specific (identified by date of publication, edition number, version number, etc.) or non-specific.
- For a specific reference, subsequent revisions do not apply.
- For a non-specific reference, the latest version applies. In the case of a reference to a 3GPP document (including a GSM document), a non-specific reference implicitly refers to the latest version of that document *in the same Release as the present document*.

Referenced documents which are not found to be publicly available in the expected location might be found at <http://docbox.etsi.org/Reference>.

For online referenced documents, information sufficient to identify and locate the source shall be provided. Preferably, the primary source of the referenced document should be cited, in order to ensure traceability. Furthermore, the reference should, as far as possible, remain valid for the expected life of the document. The reference shall include the method of access to the referenced document and the full network address, with the same punctuation and use of upper case and lower case letters.

NOTE: While any hyperlinks included in this clause were valid at the time of publication ETSI cannot guarantee their long term validity.

2.1 Normative references

The following referenced documents are indispensable for the application of the present document. For dated references, only the edition cited applies. For non-specific references, the latest edition of the referenced document (including any amendments) applies.

- [1] ETSI TS 181 002: "Telecommunications and Internet converged Services and Protocols for Advanced Networking (TISPAN); Multimedia Telephony with PSTN/ISDN simulation services".
- [2] ETSI ES 283 003: "Telecommunications and Internet converged Services and Protocols for Advanced Networking (TISPAN); IP Multimedia Call Control Protocol based on Session Initiation Protocol (SIP) and Session Description Protocol (SDP) Stage 3".
- [3] IETF RFC 4244: "An Extension to the Session Initiation Protocol (SIP) for Request History Information".
- [4] ETSI TS 183 023: "Telecommunications and Internet converged Services and Protocols for Advanced Networking (TISPAN); PSTN/ISDN simulation services; Extensible Markup Language (XML) Configuration Access Protocol (XCAP) over the Ut interface for Manipulating NGN PSTN/ISDN Simulation Services".
- [5] IETF RFC 2327: "SDP: Session Description Protocol".
- [6] IETF RFC 3261: "SIP: Session Initiation Protocol".

- [7] IETF RFC 3966: "The tel URI for Telephone Numbers".
- [8] IETF RFC 3325: "Private Extensions to the Session Initiation Protocol (SIP) for Asserted Identity within Trusted Networks".
- [9] ETSI TS 183 011: "Telecommunications and Internet converged Services and Protocols for Advanced Networking (TISPAN); PSTN/ISDN simulation services: Anonymous Communication Rejection (ACR) and Communication Barring (CB); Protocol specification".
- [10] ETSI EN 300 356-15 (V4.2.1): "Integrated Services Digital Network (ISDN); Signalling System No.7 (SS7); ISDN User Part (ISUP) version 4 for the international interface; Part 15: Diversion supplementary service [ITU-T Recommendation Q.732, clauses 2 to 5 (1999) modified]".
- [11] ETSI TS 183 028: "Telecommunications and Internet converged Services and Protocols for Advanced Networking (TISPAN); Common Basic Communication procedures; Protocol specification".
- [12] ETSI ES 282 001: "Telecommunications and Internet converged Services and Protocols for Advanced Networking (TISPAN); NGN Functional Architecture".
- [13] ETSI ES 283 027: "Telecommunications and Internet converged Services and Protocols for Advanced Networking (TISPAN); Endorsement of the SIP-ISUP Interworking between the IP Multimedia (IM) Core Network (CN) subsystem and Circuit Switched (CS) networks [3GPP TS 29.163(Release 7), modified]".
- [14] IETF RFC 4458: "Session Initiation Protocol (SIP) URIs for Applications such as Voicemail and Interactive Voice Response (IVR)".
- [15] IETF RFC 3265: "Session Initiation Protocol (SIP) -Specific Event Notification".
- [16] ETSI TS 183 029: "Telecommunications and Internet converged Services and Protocols for Advanced Networking (TISPAN); PSTN/ISDN simulation services: Explicit Communication Transfer (ECT); Protocol specification".
- [17] IETF RFC 3515: "The Session Initiation Protocol (SIP) Refer Method".
- [18] IETF RFC 4745: "Common Policy: A Document Format for Expressing Privacy Preferences".
- [19] ETSI TS 183 004 V2.4.0: "Telecommunications and Internet converged Services and Protocols for Advanced Networking (TISPAN); PSTN/ISDN simulation services: Communication Diversion (CDIV); Protocol specification".
- [20] OMA-TS-XDM-Core-V1_1: "XML Document Management (XDM) Specification", Version 1.1.
- [21] draft-avasara-dispatch-comm-div-notification-012 (July 2013): "A Session Initiation Protocol (SIP) Event Package for Communication Diversion Information in support of the Communication Diversion (CDIV) Notification (CDIVN) CDIV service".

Editor's note: The above document cannot be formally referenced until it is published as an RFC.

- [22] IETF RFC 3326: "The Reason Header Field for the Session Initiation Protocol (SIP)".
- [23] IETF RFC 5627 (October 2009): "Obtaining and Using Globally Routable User Agent URIs (GRUUs) in the Session Initiation Protocol (SIP)".
- [24] IETF RFC 3023 (January 2001): "XML Media Types".
- [25] IETF RFC 4288 (December 2005): "Media Type Specifications and Registration Procedures".

3 Definitions and abbreviations

3.1 Definitions

For the purposes of the present document, the terms and definitions given in ETSI TS 181 002 [1] and the following apply:

CDIV Session Identifier URI: URI created and inserted by a diverting AS that is routed through the same AS

NOTE: This is used to solve the service interaction of CDIV and ECT.

escaped character: See IETF RFC 3261 [6].

transferee: party being transferred to the transfer target

transferor: party initiating the transfer

transfer target: party that the existing communication is transferred to

NOTE: After transfer the transferee and the transfer target are in communication with each other.

3.2 Abbreviations

For the purposes of the present document, the following abbreviations apply:

ACK	ACKnowledgement
ACM	Address Complete Message
ACR	Anonymous Communication Rejection
ANM	ANswer Message
AS	Application Server
CB	Communication Barring
CD	Communication Deflection
CDIV	Communication DIVersion
CDIVN	Communication DIVersion Notification
CFB	Communication Forwarding Busy
CFNL	Communication Forwarding on Not Logged-in
CFNR	Communication Forwarding No Reply
CFNRc	Communication Forwarding on subscriber Not Reachable
CFU	Communication Forwarding Unconditional
CONF	CONFerence
CPC	Calling Party's Category
CPG	Call ProGress message
CSCF	Call Session Control Function
ECT	Explicit Communication Transfer
HOLD	communication HOLD
IAM	Initial Address Message
IFC	Initial Filter Criteria
IMS	IP Multimedia Subsystem
IP	Internet Protocol
ISDN	Integrated Service Data Network
ISUP	Integrated Service digital network User Part
IWU	Inter Working Unit
MCID	Malicious Communication IDentification
MGCF	Media Gateway Control Function
NDC	National Destination Code
NGN	Next Generation Network
NOA	Nature Of Address
OCB	Outgoing Communication Barring
OIP	Originating Identification Presentation
OIR	Originating Identification Restriction

O-MGCF	Outgoing - Media Gateway Control Function
P-CSCF	Proxy-Call Session Control Function
PSTN	Public Switched Telephone Network
RTP	Real-Time Transport Protocol
S-CSCF	Server-Call Session Control Function
SDP	Session Description Protocol
SIP	Session Initiation Protocol
SN	Subscriber Number
TIP	Terminating Identification Presentation
TIR	Terminating Identification Restriction
UA	User Agent
UE	User Equipment
URI	Universal Resource Identifier
XCAP	XML Configuration Access Protocol
XML	eXtensible Markup Language

4 Communications Diversion (CDIV)

4.1 Introduction

The Communications Diversion (CDIV) service enables diverting user, to divert the communications addressed to diverting user to an other destination.

4.2 Description

4.2.1 General description

The service description of the following Communication Services CFU, CFB, CFNR and CD is based on the PSTN/ISDN Supplementary Services, whereas CFNL is Communication service based on requirements for IP based networks and CFNRc is based on requirements for mobile networks.

In addition, CDIVN is a communication service providing the user the capability to receive notifications about all diverted communications (CFU, CFB, CFNR, CD, CFNRc and CFNL).

Generally the following requirements should be fulfilled:

- It shall be possible for the user or the network to identify an alternative destination for an IP multimedia session or individual media of an IP multimedia session.
- It shall be possible for redirection to be initiated at various stages of an IP Multimedia session. For example:
 - Prior to the set up of an IP Multimedia session.
 - During the initial request for an IP Multimedia session (CFU).
 - During the establishment of an IP Multimedia session (CD).
- Redirection can be applied for all Multimedia sessions unconditionally or it can be caused by any of a set list of events or conditions. Typical causes could be:
 - Identity of the originating user.
 - Presence of the originating or destination party.
 - If the destination party is already in a session (CFB).
 - If the destination party is unreachable or unavailable in some other way (CFNL; CFNR, CFNRc).
 - If the destination party does not respond (CFNR).

- After a specified alerting interval (CFNR).
 - User's preference on routing for specific IP Multimedia session based on the capabilities of multiple UEs sharing the same IMS service subscription.
 - The sending party, receiving party or the network on their behalf, may initiate redirection to alternative destinations.
- It shall be possible for the user to subscribe to receive notifications of his/her communications diversions as dictated by the above requirements. The user will be further able to control:
 - If he/she wants to be notified of all or a particular subset of his/her Communication Diversions.
 - The amount of information he/she wishes to see as a part of the notifications of his/her CDIV services.
 - The time interval or availability instance when he/she wants to be notified of his/her Communication Diversions.

The following services describe applications based on a subset of the above-mentioned requirements to provide user different possibilities to divert a communication.

It should be possible that a user has the option to restrict receiving communications that are forwarded.

Communication Forwarding Unconditional (CFU)

The CFU service enables a served user to have the network redirect to another user communications which are addressed to the served user's address. The CFU service may operate on all communications, or just those associated with specified services. The served user's ability to originate communications is unaffected by the CFU supplementary service. After the CFU service has been activated, communications are forwarded independent of the status of the served user.

As a service provider option, a subscription option can be provided to enable the served user to receive a reminder indication that the CFU service has been activated. This indication shall be provided when the served user originates a communication and if the CFU service has been activated for the served user's address and for the service requested for the communication.

The maximum number of diversions permitted for each communication is a service provider option. The service provider shall define the upper limit of diversions. When counting the number of diversions, all types of diversion are included.

Communication Forwarding on Busy user (CFB)

The CFB service enables a served user to have the network redirect to another user communications which are addressed to the served user's address and meet busy. The CFB service may operate on all communications, or just those associated with specified services. The served user's ability to originate communications is unaffected by the CFB supplementary service.

As a service provider option, a subscription option can be provided to enable the served user to receive a reminder indication that the CFB service has been activated. This indication shall be provided when the served user originates a communication and if the CFB service has been activated for the served user's address and for the service requested for the communication.

The maximum number of diversions permitted for each communication is a service provider option. The service provider shall define the upper limit of diversions. When counting the number of diversions, all types of diversion are included.

For more information on the procedures for determination of the busy condition see ES 183 028 [11].

Communication Forwarding on no Reply (CFNR)

The CFNR service enables a served user to have the network redirect to another user communications which are addressed to the served user's address, and for which the connection is not established within a defined period of time. The CFNR service may operate on all communications, or just those associated with specified services. The served user's ability to originate communications is unaffected by the CFNR supplementary service.

The CFNR service can only be invoked by the network after the communication has been offered to the served user and an indication that the called user is being informed of the communication has been received.

As a service provider option, a subscription option can be provided to enable the served user to receive a reminder indication that the CFNR service has been activated. This indication shall be provided when the served user originates a communication and if the CFNR service has been activated for the served user's address and for the service requested for the communication.

The maximum number of diversions permitted for each communication is a service provider option. The service provider shall define the upper limit of diversions. When counting the number of diversions, all types of diversion are included.

Communication Forwarding on Subscriber Not Reachable (CFNRc)

The CFNRc service enables a user to have the network redirect all incoming communications, when the user is not reachable (e.g. there is no IP connectivity to the user's terminal), to another user. The CFNRc service may operate on all communications, or just those associated with specified services. The user's ability to originate communications is unaffected by the CFNRc simulation service.

As a service provider option, a subscription option can be provided to enable the user to receive an indication that the CFNRc service has been activated. This indication may be provided when the user originates a communication if the CFNRc service has been activated for the user and for the service requested for the communication.

The maximum number of diversions permitted for each communication is a service provider option. The service provider shall define the upper limit of diversions. When counting the number of diversions, all types of diversion are included.

Communication Deflection (CD)

The CD service enables the served user to respond to an incoming communication by requesting redirection of that communication to another user. The CD service can only be invoked before the connection is established by the served user, i.e. in response to the offered communication (before ringing), i.e. CD Immediate, or during the period that the served user is being informed of the communication (during ringing). The served user's ability to originate communications is unaffected by the CD supplementary service.

The maximum number of diversions permitted for each communication is a network provider option. The network provider shall define the upper limit of diversions. When counting the number of diversions, all types of diversion are included.

Communication Forwarding on Not Logged-in (CFNL)

The Communication Forwarding on Not Logged-in (CFNL) service enables a served user to redirect incoming communications which are addressed to the served user's address, to another user (forwarded-to address) in case the served user is not registered (logged-in). The CFNL service may operate on all communications, or just those associated with specified basic services.

As a service provider option, a subscription option can be provided to enable the served user to receive a reminder indication that the CFNL service has been activated. This indication shall be provided when the served user logs out according to procedures described in RFC 3261 [6].

The maximum number of diversions permitted for each communication is a service provider option. The service provider shall define the upper limit of diversions. When counting the number of diversions, all types of diversion are included.

Communication Diversion Notification (CDIVN)

The Communication Diversion Notification (CDIVN) service enables a served user to receive notification about the diversion of any of his/her incoming communications, which were addressed to the served user's address.

As a service provider option, a subscription option can be provided to enable the served user to receive a reminder indication that the CDIVN service has been activated. This indication shall be provided when the served user originates a communication and if the CDIVN service has been activated for the served user's address.

In case the user is not available to receive CDIVN (ex. user is logged out or not reachable) the Notification will be provided to the user following the user's registration, in case of CFNL when the user's CDIVN activation is still valid and if the time to buffer the Notification (CDIVN Buffer Timer) in the AS has not expired.

NOTE: In case of CFNL and CRNRc, CDIVN activation continues to be valid after user registration in case the user uses the same user's address as before having that status of no connectivity and the time of SUBSCRIBE/NOTIFY messages has not expired in the AS.

4.3 Operational requirements

4.3.1 Provision/withdrawal

The CDIV services (Communication forwarding unconditional, Communication forwarding busy, Communication forwarding no reply, Communication forwarding not logged-in, Communication deflection and Communication Diversion Notification) shall be provided after prior arrangement with the service provider.

The CDIV services shall be withdrawn at the served user's request or for administrative reasons.

The CDIV simulation services can be offered separately with subscription options. The notification service CDIVN is offered together with at least one CDIV simulation service. For each subscription option, only one value can be selected. These subscription options are part of the call diversion profile for the served user. The subscription options are shown in table 4.3.1.1.

Table 4.3.1.1: Subscription options for CDIV services

Subscription options	Value	Applicability
<i>Served user</i> receives indication that a communication has been forwarded (indication of communication diversion to the diverting user).	No (default) Yes	CFU CFB CFNR CFNR _c
<i>Originating user</i> receives notification that his communication has been diverted (forwarded or deflected).	No Yes (default)	CFU CFB CFNR CFNR _c CFNL CD
Served user allows the presentation of diverted to URI to <i>originating user</i> in diversion notification.	No Not reveal as GRUU Yes (default)	CFU CFB CFNR CFNR _c CFNL CD
Served user receives reminder indication on outgoing communication that CDIV is currently activated.	No (default) Yes	CFU CFB CFNR CFNR _c CFNL CDIVN
Served user allows the presentation of his/her URI to <i>diverted-to user</i> .	No Not reveal as GRUU Yes (default)	CFU CFB CFNR CFNR _c CFNL CD
Served user allows the presentation of his/her URI to <i>originating user</i> in diversion notification.	No Not reveal as GRUU Yes (default)	CFU CFB CFNR CFNR _c CFNL CD

The following network provider options are available for the CDIV services:

Table 4.3.1.2: Network provider options for CDIV services

Network provider option	Value	Applicability
Served user communication retention on invocation of diversion (forwarding or deflection).	Retain communication to the served user until alerting begins at the diverted-to user Clear communication to the served user on invocation of call diversion	CFNR CD

Served user communication retention when diverting is rejected at diverted-to user.	Continue to alert the diverting user (see note 1)	CFNR CD
	No action at the diverting user (see note 2)	
Subscription option is provided for "served user receives reminder indication on outgoing communication that CDIV is currently activated".	No	CFU CFB CFNR CFNRc CFNL CDIVN
	Yes	
Total number of all diversions for each communication.	Maximum number of diverted connections (upper limit is based on operator policy)	CFU CFB CFNR CFNRc CFNL CD
CDIV Indication Timer.	Timer duration shall be a service provider option	CFU CFB CFNR CFNRc CFNL CD
Communication forwarding on no reply timer.	Timer default duration shall be a service provider option (NOTE 3)	CFNR
CDIVN Buffer Timer; Timer Value for AS to store CDIVN, if it cannot be delivered as per CDIVN Configuration.	Timer duration set by the service provider. Default value is 1 day	CFNL, CFNRc in case of CDIVN
NOTE 1: This applies to the retention of the communication at invocation of communication diverting.		
NOTE 2: This applies to the clearing communication option on invocation of communication diverting.		
NOTE 3: As a network provider option, It shall be possible to change the timer duration by the served user..		

For user configuration of the CDIV the Ut interface described in ES 282 001 [12] could be used. More detail is described in clause 4.9.

Other possibilities for provisioning could be used too, like web based provisioning or pre-provisioning by the operator.

4.3.2 Requirements on the originating network side

No specific requirements are needed in the network.

4.3.3 Requirements in the network

No specific requirements are needed in the network.

4.4 Coding requirements

ES 283 003 [2] defines the messages and parameters for this simulation service. The following messages and parameters are used to support the Communication diversion service due to fulfil the requirements.

4.4.1 SIP-Messages

4.4.1.1 SIP messages for redirection

The following SIP messages are used due to the coding rules in ES 283 003 [2].

Table 4.4.1.1: SIP Header information for redirection

SIP Message	Reference	SIP Header
INVITE	[3] [8] [14] [23]	History-Info header Privacy header cause-param URI parameter "gr" URI parameter
180 (Ringing)	[3] [8] [14] [23]	History-Info header Privacy header cause-param URI parameter "gr" URI parameter in the Contact
181 (Call Is Being Forwarded)	[3] [8] [14] [23]	History-Info header Privacy header cause-param URI parameter "gr" URI parameter in the Contact
200 (OK) response	[3] [8] [14] [23]	History-Info header Privacy header cause-param URI parameter "gr" URI param URI parameter
302 (Moved Temporarily) (see note)	[2] [14]	Contact header cause-param URI parameter
NOTE: The 302 (Moved Temporarily) response is in the present document only used for the CD services.		

More information on the cause-param URI parameter is given in annex C.

An AS that implements the CDIV service shall support the REFER method RFC 3515 [17], to be able to handle the interaction with ECT TS 183 029 [16].

4.4.1.2 SIP messages for CDIVN

The following SIP messages are used for the CDIVN according to the coding rules in ES 283 003 [2]. SIP specific Event Notifications shall be used in accordance with IETF RFC 3265 [15] including as referenced in draft-avasarala-dispatch-comm-div-notification [21].

Table 4.4.1.2: SIP Header information for notification (CDIVN)

SIP Message	Reference	SIP Header
SUBSCRIBE	[15]	Event:comm-div-info
NOTIFY	[15]	Event:comm-div-info
NOTE: The event package with event name "comm-div-info" based on the SIP Event Notification framework is defined in draft-avasarala-dispatch-comm-div-notification [21].		

For more information on the message body associated with the event package "comm-div-info" refer to subclause 4.10.

4.4.2 Parameters

The Privacy header is described in ES 283 003 [2]. The present document refers for the History-Info header to RFC 4244 [3], for the Privacy header and P-Asserted-Identity to RFC 3325 [8], for GRUU to RFC 5627 [23] and for the cause-param to RFC 4458 [14].

4.5 Signalling requirements

4.5.0 General

For user configuration of the CFU, CFB, CFNR, CFNL, CFNRc and CD services the Ut interface should be used.

See clause 4.9 for further information about the structure of the XML document.

NOTE: Other possibilities for user configuration, as web-based provisioning or pre-provisioning by the operator are outside the scope of the present document.

4.5.1 Activation/deactivation

The services CFU, CFB, CFNR, CFNL, CFNRc and CD are individually activated at provisioning or at the subscribers request by using for example the Ut interface.

The services CFU, CFB, CFNR, CFNL, CFNRc and CD are individually deactivated at withdrawal or at the subscribers request by using for example the Ut interface.

For activation of the CDIVN, the message body within the SUBSCRIBE method would be used. Deactivation of CDIVN is either explicit by sending SUBSCRIBE message by the served user with "Expires" header set to "zero" or upon the expiration of the timer "Expire" in the AS. More details are described in clause 4.10.

4.5.1a Registration/erasure

For registration of diversion information for the services CFU, CFB, CFNR, CFNL, CFNRc and CD, the Ut interface should be used. The diverted-to party address of the services CFU, CFB, CFNR, CFNL, CFNRc and CD can individually be registered at the subscribers request by using the Ut interface.

For erasure of diversion information for the services CFU, CFB, CFNR, CFNL, CFNRc and CD, the Ut interface should be used. The diverted-to party address of the services CFU, CFB, CFNR, CFNL, CFNRc and CD can individually be erased at the subscribers request by using the Ut interface.

Registration/erasure is not applicable for CDIVN.

4.5.1b Interrogation

For interrogation of the services CFU, CFB, CFNR, CFNL, CFNRc and CD, the Ut interface should be used.

Interrogation is not applicable for CDIVN.

4.5.2 Invocation and operation

4.5.2.1 Actions at the originating UA

When communication diversion has occurred on the served user side and the network option "*Originating* user receives notification that his communication has been diverted (forwarded or deflected)" is set to true, the originating UA may receive a 181 (Call is being forwarded) response according to the procedures described in ES 283 003 [2].

The Information given by the History-Info header could be displayed by the UA if it is a UE.

4.5.2.2 Actions at the originating P-CSCF

Procedures according to ES 283 003 [2] shall apply.

4.5.2.3 Actions at the originating S-CSCF

Procedures according to ES 283 003 [2] shall apply.

4.5.2.4 Actions at the diverting S-CSCF

Procedures according to ES 283 003 [2] shall apply.

Based on the Initial Filter Criteria (IFC) Rules, indicating that the served user is subscribed to the CDIV simulation services, the communication is be forwarded to an AS.

NOTE: An example of the use of IFC is shown in annex B.

4.5.2.5 Actions at the diverted to S-CSCF

Procedures according to ES 283 003 [2] shall apply.

4.5.2.6 Actions at the AS of the diverting User

4.5.2.6.1 Checking of the diversion limits

When receiving an INVITE request and the AS determines that the AS shall divert a communication the AS shall check if diverting the communication exceeds the number of diversions allowed within the network. The AS shall calculate the number of diversions by examination of the History-Info header field:

- using the entries including a cause-param URI parameter with cause values specified in subclause 4.5.2.6.2.2; or
- examining the entries in the Index entries parameter;

to see if another diversion is allowed due to network provider allowed_limit of diversions.

If the number of diversions exceed the given limit then the following response sent to the originating user shall apply:

- a) communication diversion forwarding busy a 486 (Busy here) shall be sent;
- b) communication forwarding no reply, 480 (Temporarily unavailable) shall be sent;
- c) communication forwarding unconditional 480 (Temporarily unavailable) shall be sent;
- d) communication deflection, 480 (Temporarily unavailable) shall be sent.

NOTE: It is based on operator policy that the communication can be delivered to the latest diverting party when it is known.

In all cases a Warning header field indicating that the communication is released due to the extension of diversion hops (e.g. "Too many diversions appeared") shall be sent.

4.5.2.6.2 Setting of the diversion parameters by the AS

4.5.2.6.2.1 Overview

After checking the limit of diversions the following settings of the INVITE request shall be performed.

4.5.2.6.2.2 Diversion where served user is not last in received History-Info header

If an AS determines that the AS shall divert a communication and the AS shall apply the procedures in the present subclause if any of the following conditions apply for the received INVITE request:

- no History-Info header field received; or
- a History-Info header field is received in which the last history-info entry contains no hi-targeted-to-uri element for the served user.

The following information is to be set in the retargeted request:

- the diverting parties address;
- the diverted-to party address;

- diversion information.

The following header fields shall be included or modified with the specified values:

- a) **The Request URI** - shall be set to the SIP, TEL or SIPS URI where the communication is to be diverted to (see <target> element in clause 4.9.1.4).

The AS shall add the cause-param as defined by RFC 4458 [14] to the request URI. The mapping between the diversion conditions and the coding of the cause-param parameter values as defined by RFC 4458 [14] shall be as follows:

- for communication forwarding busy, the cause value "486";
- for communication forwarding no reply, the cause value "408";
- for communication forwarding unconditional, the cause value "302";
- for communication deflection (Immediate Response), the cause value "480";
- for communication forwarding not logged in , the cause value "404";
- for communication deflection during alerting, the cause value "487"; and
- for communication forwarding on subscriber not reachable, the cause value "503".

- b) **The History-Info header** field - Two hist-info entries that shall be generated.

- b.1) The first entry includes the hi-targeted-to-uri of the served user.

The privacy header "history" shall be escaped within the hi-targeted-to-uri, if:

- the served user wishes privacy (e.g. the served user is subscribed to the OIR Service); or
- the served user has the subscription option "Served user allows the presentation of his/her URI to diverted-to user" set to false.

Otherwise, if the first entry contains the "gr" parameter and the subscription option "Served user allows the presentation of his/her URI to *diverted-to* user" is set to "not-reveal-as-GRUU", then it shall be changed as follows:

- replace the first entry with the public user identity of the served user.

If the diversion is based on a SIP response from the served user, a Reason header as defined in RFC 3326 [22] shall be included in escaped form in the hi-targeted-to-uri in accordance with RFC 4244 [3].

- b.2) The second entry includes the new Request URI as described under bullet a) as hi-targeted-to-uri .

NOTE: In accordance with RFC 4458 [14], hi-targeted-to-uri will contain a cause-param in non-escaped format.

- c) **The To header** field:

If the served user does not want to reveal its identity to the diverted-to party, then the To header shall be changed to the URI where the communication is diverted to. The served user does not want to reveal its identity when one of the following conditions holds true:

- if the served user wishes privacy (e.g. the served user is subscribed to the OIR Service); or
- if the served user has the subscription option "Served user allows the presentation of his/her URI to diverted-to user" set to "false".

Otherwise, if the To header contains the "gr" parameter and the served user has the subscription option "Served user allows the presentation of his/her URI to diverted-to user" set to "not-reveal-as-GRUU", then the To header field shall be changed to a public user identity of the served user.

In all other cases the To header shall not be changed.

4.5.2.6.2.3 Diversion with served user last in received History-Info header

If an AS determines that the communication shall be diverted the AS shall apply the procedures in the present subclause if the received INVITE request includes a History-Info header, which in the last history-info entry includes a hi-targeted-to-uri with an entry for the served user, encoded as in subclause 4.5.2.6.2.2. In this case the AS shall add a new history-info entry to the History-Info header field according to the rules defined in RFC 4244 [3]. The following information has to be added to the retargeted request:

- the diverted-to party address;
- diversion information.

The following header fields shall be included or modified with the specified values;

- a) **Request URI** - shall be set to the SIP, TEL or SIPS URI where the communication is to be diverted to (see <target> element in subclause 4.9.1.4).

The AS shall add the cause-param as defined by RFC 4458 [14] to the request URI. The mapping between the diversion conditions and the coding of the cause-param parameter shall be as defined under bullet a) in subclause 4.5.2.6.2.2.

- b) **History-Info header** shall be modified in accordance with RFC 4244 [3]. The history entry corresponding to the previous request URI can be modified. One history entry is added.

b.1) The existing history entry corresponding to the previous request URI shall be treated as follows:

If the Privacy header field does not contain "history", the privacy header "history" in escaped format shall be added or modified within the hi-targeted-to-uri, if:

- the served user wishes privacy (e.g. the served user is subscribed to the OIR Service); or
- the served user has the subscription option "Served user allows the presentation of his/her URI to diverted-to user" set to false.

If the history entry representing the served user contains the "gr" parameter and the subscription option "Served user allows the presentation of his/her URI to *diverted-to* user" set to "not-reveal-as-GRUU", it shall be changed to a public user identity of the served user.

If the diversion is based on a SIP response from the served user, a Reason header in escaped form shall be included in accordance with RFC 4244 [3].

b.2) A history entry shall be added containing the new Request URI as described under bullet a) as hi-targeted-to-uri

NOTE: In accordance with RFC 4458 [14], hi-targeted-to-uri will contain a cause-param in non-escaped format.

c) **To header:**

If the served user does not want to reveal its identity to the diverted-to party, then the To header shall be changed to the URI where the communication is diverted to. The served user does not want to reveal its identity when one of the following conditions holds true:

- if the served user wishes privacy (e.g. the served user is subscribed to the OIR Service); or
- if the served user has the subscription option "Served user allows the presentation of his/her URI to diverted-to user" set to false.

Otherwise, if the To header contains the "gr" parameter and the served user has the subscription option "Served user allows the presentation of his/her URI to *diverted-to* user" set to "not-reveal-as-GRUU", then the To header shall be changed to a public user identity of the served user.

In all other cases the To header shall not be changed.

4.5.2.6.2.4 Overview of the operation

Figure 4.5.2.6.2.4 shows the example of a communication path for multiple diversions.

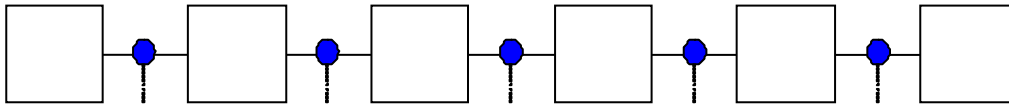

Figure 4.5.2.6.2.4: Originally A calls B Information transferred in the INVITE request

Table 4.5.2.6.2.4 shows which parameters and header fields that are added or modified in a diversion AS.

Table 4.5.2.6.2.4: Parameter information for multiple redirections

	HOP 1	HOP 2	HOP 3			HOP 4		HOP 5				
Number Information:												
P-Asserted-Identity	A	A	A	A	A	A	A	A	A	A		
Request URI	B	C	D	D	D	E	E	F	F	F		
hi-entry		B	C	B	C	D	B, C	D	E	B, C, D	E	F
Information added:												
hi-targeted-to-uri		B	C	No changes	D	No changes	E	F	No changes	F	F	
Reason header (NOTE 2)		V		V		V	U	V	U	V	U	
cause-param (NOTE 3)			U		U							
Privacy		W		W		W				W		
Hi-index (NOTE 1)		index 1	index 2	No changes	index 3	No changes	index 4				index 5	

U = Value for the cause-param parameter as specified in 4.5.2.6.2.2 and 4.5.2.6.2.3

V = Value in accordance with the rules in RFC 4244 [3].

W = privacy value (history) or (none) or no entry.

NOTE 1: The hi-index field shall be set or incremented according to the basic forwarding rules as specified in subclause 4.3.3.1.3 of RFC 4244 [3].

NOTE 2: The encoding of the reason header and the contained protocol-cause parameter are specified in RFC 3326 [22]. It is embedded in the hi-targeted-to-uri of the history info header in escaped format according to the rules in RFC 4244 [3].

NOTE 3: The cause-param is specified in RFC 4458 [14]. It is embedded in the hi-targeted-to-uri of the history info header in non-escaped format according to the rules in RFC 4458 [14].

4.5.2.6.3 Diversion procedures at the diverting AS

The diverting AS shall continue the communication depending on the service that is causing the diversion:

1) Communication Forwarding Unconditional or Communication Forwarding Busy network determined user busy or Communication for warding on Not Logged in

The AS shall continue in the following manner:

- If the notification procedure of the originating user is supported then the originating user shall be notified as described in the clause 4.5.2.6.4.
- An INVITE request containing the diverted-to URI shall sent to the (outgoing) S-CSCF. The INVITE request shall includes the parameter information as shown in table 4.5.2.6.2.4 and described in clause 4.5.2.6.2.
 - If the served user has subscribed to the indication of communication diversion to the diverting user and/or CDIVN service, then the served user will be indicated to/notified of the communication diversion as described in clause 4.5.2.6.5.
 - If the user has activated both CFNL and CDIVN, and CFNL was invoked then the AS will store the CDIVN according to the CDIVN Buffer Timer for a default time of 1 day set by the service provider.

The user has the option of overwriting this timer value in the SUBSCRIBE message to the maximum value of 1 day. See clause 4.10.1.1.2 for more details.

2) Communication Forwarding No Reply

After receiving the first 180 (Ringing) response the no reply timer (definition see clause 4.8) shall be started. If forking is provided by the S-CSCF a further received 180 (Ringing) response does not refresh the timer.

With receiving a 200 (OK) response the no reply timer shall be terminated and the call follows the Basic call procedure as described within ES 283 003 [2]. Other open early dialogs shall be terminated as described within ES 283 003 [2], clause 9.2.3.

When the no reply timer defined in clause 4.8 expires:

The dialog(s) to the diverting user shall be terminated e.g. by sending a CANCEL request or BYE request according to the rules and procedures in RFC 3261 [6].

If the notification procedure of the originating user is supported then the originating user shall be notified as described in the clause 4.5.2.6.4.

An INVITE request is sent to the (outgoing) S-CSCF towards the diverted-to user. The INVITE request includes the parameter information as shown in table 4.5.2.6.2.4.

If the served user has subscribed to the indication of communication diversion to the diverting user and/or the CDIVN service, then the served user will be notified of the communication diversion as described in clause 4.5.2.6.5.

3) Communication Forwarding No Reply (ringing continues)

After receiving the first 180 (Ringing) response the no reply timer (definition see clause 4.8) shall be started. If forking is provided by the S-CSCF a further received 180 (Ringing) response does not refresh the timer.

When the diverted-to-user has accepted the communication request (with 200 OK) then the originating user shall be notified as described in clause 4.5.2.6.4.

An INVITE is sent to the outgoing S-CSCF towards the diverted to user. The INVITE address message includes the parameter information as shown in table 4.5.2.6.2.4.

If the served user has subscribed to the indication of communication diversion to the diverting user and/or the CDIVN service, then the served user will be notified of the communication diversion as described in clause 4.5.2.6.5.

If diverting user accepts the communication after sending the INVITE request the communication path towards the diverted to user shall be released according to the rules and procedures in RFC 3261 [6].

4) Communication Forwarding User Determined Busy

The Communication Forwarding User Determined Busy is offered to the served user when the AS:

- The received 486 Busy shall be acknowledged with a ACK.
- If the notification procedures of the originating user is supported then the originating user shall be notified as described in the clause 4.5.2.6.4.
- An INVITE message containing the diverted-to URI is sent to the outgoing S-CSCF. The INVITE address message includes the parameter information as shown in table 4.5.2.6.2.4.
- If the served user has subscribed to the indication of communication diversion to the diverting user and/or the CDIVN service, then the served user will be notified of the communication diversion as described in clause 4.5.2.6.5.

5) Communication Deflection immediate response

The Communication Deflection immediate response is offered to the served user.

A 302 (Moved Temporarily) response is received.

If the notification procedures of the originating user is supported then the originating user shall be notified as described in clause 4.5.2.6.4.

An INVITE message containing the diverted-to URI is sent to the outgoing S-CSCF. The INVITE address message includes the parameter information as shown in table 4.5.2.6.2.4.

If the served user has subscribed to the indication of communication diversion to the diverting user and/or the CDIVN service, then the served user will be notified of the communication diversion as described in clause 4.5.2.6.5.

6) Communication Deflection during alerting

When Communication Deflection during alerting is invoked after the AS receives a 180 (Ringing) "Ringing" response, then:

- A 302 (Moved Temporarily) response is received; and
- if the notification procedures of the originating user is supported then the originating user shall be notified as described in clause 4.5.2.6.4; and
- an INVITE request containing the URI received in the Contact header of the 302 as the diverted-to URI shall be sent as specified in ES 283 003 [2]. The diverted-to URI could be restricted by setting the privacy header for the entry of the diverted-to URI to "history"; and
- the INVITE request shall include the parameter information as shown in table 4.5.2.6.2.4 "Parameter information for multiple redirection". If the served user has subscribed to the indication of communication diversion to the diverting user and/or the CDIVN service, then the served user will be notified of the communication diversion as described in clause 4.5.2.6.5.

7) Communication Forwarding on Subscriber Not Reachable

When the AS receives a not reachable indication (see clause 4.5.2.6.6) on the INVITE forwarded to the served user, then the following criteria shall apply before the Communication Forwarding on Subscriber Not Reachable procedure is executed:

- the served user has an active forwarding rule containing not-reachable condition (see clause 4.9); and
- the served user is registered.

The following steps shall be followed to perform Communication Forwarding on Subscriber Not Reachable:

- 1) If the notification procedures of the originating user is supported then the originating user shall be notified as described in the clause 4.5.2.6.4.
- 2) An INVITE message containing the diverted-to URI is sent to the outgoing S-CSCF. The INVITE address message includes the parameter information as shown in table 4.5.2.6.2.4.

If the served user has subscribed to the indication of communication diversion to the diverting user and/or CDIVN service, then the served user will be indicated to/notified of the communication diversion as described in clause 4.5.2.6.5.

If the user has activated both CFNRc and CDIVN, and CFNRc was invoked then the AS will store the CDIVN according to the CDIVN Buffer Timer for a default time of 1 day set by the service provider. The user has the option of overwriting this timer value in the SUBSCRIBE message to the maximum value of 1 day. See clause 4.10.1.1.1.2 for more details.

4.5.2.6.4 Notification procedures of the originating user (Subscription Option)

When Communication Diversion occurs and if served user has the subscription option "*Originating* user receives notification that his communication has been diverted (forwarded or deflected)." set to true then a 181 (Call Is Being Forwarded) response shall be sent towards the originating user.

The following header fields shall be included or modified with the specified values:

- a) The **P-Asserted-Identity** includes the URI of the diverting user.

- b) The **Privacy** header with the value "id" shall be included, if:
- the served user wishes privacy (e.g. the served user is subscribed to the TIR Service); or
 - the served user has the subscription option "Served user allows the presentation of his/her URI to *originating* user in diversion notification." set to false.
- c) The following entries shall be added to the **History-Info** header field:
- c.1) If this is the first diversion then the first entry shall be populated with the hi-targeted-to-uri of the served user. The Index is set to index = 1 according to the rules specified in RFC 4244 [3].
- c.2) On the history entry that represents the served user:
- the privacy header with value "history" shall be escaped within the hi-targeted-to-uri, if:
- the served user wishes privacy (e.g. the served user is subscribed to the TIR Service); or
 - the served user has the subscription option "Served user allows the presentation of his/her URI to *originating* user in diversion notification." set to false.
- If the history is already escaped with the correct privacy value no modification is needed.
- If the history entry representing the served user contains the "gr" parameter and the served user has the subscription option "Served user allows the presentation of his/her URI to *originating* user in diversion notification" set to "not-reveal-as-GRUU", it shall be changed to the public user identity of the diverted-to user.
- In all other cases the history entry representing the served user shall not be changed.
- c.3) A history entry shall be added according to the rules of clause 4.5.2.6.2.3 item b.2. In addition, for this entry.
- c.3.1) if the history entry representing the forwarded to URI contains the "gr" parameter and the served user has the subscription option "Served user allows the presentation of forwarded to URI to *originating* user in diversion notification" set to "not-reveal-as-GRUU", it shall be changed to the public user identity of the diverted-to user.
- c.3.2) the privacy header with value "history" shall be escaped within the hi-targeted-to-uri, if the served user has the subscription option "Served user allows the presentation of forwarded to URI to *originating* user in diversion notification" set to "false".

Additional the AS may initiate an announcement to be included towards the calling user in order to inform about the diversion. Announcements may be played according to procedures as are described in TS 183 028 [11].

4.5.2.6.5 Indication of communication diversion to the diverting user /CDIV Notification_ (subscription option)

If the subscription option "Served user receives notification that a communication has been forwarded" has been set to "yes", one or a combination of the following procedures are possible:

- 1) When the diverting user is registering to the communication system, the AS sends a MESSAGE request including the information where his calls are diverted to if any. As an option; the MESSAGE request may be sent to the user after a period of time according to the timer value T_{CDIV_IND} as defined in clause 4.8.3 that can be provided by the user.
- 2) A diverting user will be informed periodically with a MESSAGE request the information where the call is diverted to.

NOTE 1: A diverting user could be informed via a Voice mail or Message mail system in the communication states described above.

- 3) If the subscription option "Served user receives reminder notification on outgoing communication that CDIV is currently activated" has been set to "yes", then a diverting user will be informed with a MESSAGE request after

the diverting user has initiated a new outgoing communication. The MESSAGE request includes the information where the call is diverted to.

NOTE 2: A diverting user could be informed via a Voicemail or Message mail system in the communication states described above.

The description of information text contained in the MESSAGE request is out of scope of the present document.

If CDIVN has been activated according to subclause 4.5.1, then:

- The diverting AS will invoke the CDIV Notification to notifying the diverting user when CDIVN is activated. This notification is applicable for all the communication diversions which were selected by the user whilst subscribing to the CDIVN service; and
- If a NOTIFY request is sent due to the CDIV Notification, the NOTIFY request shall include a Content-Type header field set to "application/vnd.3gpp.comm-div-info+xml" and a corresponding body part with the <comm-div-info-type> element with a <comm-div-ntfy-info> child element (see annex E).

4.5.2.6.5.1 Communication Diversion Notification procedure of the served user

When Communication Diversion occurs and if the CDIVN service of the served user is supported in the network and the user has activated the CDIVN service according to subclause 4.5.1, the UE will receive a NOTIFY message according to preferences passed in a SUBSCRIBE request to an AS.

If the SUBSCRIBE request sent to the AS contains a Communication Diversion Notification XML body part, in accordance with annex E:

- the request shall include a Content-Type header field set to "application/vnd.3gpp.comm-div-info+xml"; and
- the body part shall include a <comm-div-info-type> element with a <comm-div-sub-info> child element.

In case of CFNL and CFNRc, the AS will store the CDIVN for a period of time, see clause 4.5.2.6.3. Upon user's registration, if previous subscription is not valid at that point of time (see clause 4.2.1), the user may activate CDIVN by sending SUBSCRIBE message. As a consequence, the user will receive a NOTIFY message accordingly including his stored notifications.

If the served user has subscribed to the Communication Diversion Notification service, then the diverting AS continues in the following manner:

- Identify and match the communication diversion selection criteria as mentioned by the user to select the communication diversions which have to be notified to the user. Such selection may be based on:
 - Identity of the Originating user.
 - Identity of the served user.
 - Identity of the diverted-to user.
 - Time-range of the Communication Diversion.
 - Reason for the Communication Diversion.
- Identify the amount of information which the served user has selected for including in the notification. By default, all the following information should be sent to the user. The served user has the option of disabling any of the following information, if he/she is not interested in:
 - information about the originating user;
 - information about the served user;
 - information about the diverted-to user;
 - time of the Communication Diversion;
 - reason for the Communication Diversion;

- information about the rule which triggered the communication diversion.
- Identify the trigger criteria of sending the notification to the served user. By default, the notification should be sent immediately to the served user otherwise it may be based on the following:
 - Suitable Time-range for delivering the notification.
 - A particular availability status of the served user.

4.5.2.6.5.2 Interaction of CDIVN and Indication of communication diversion to the diverting user procedures

If the CDIVN service of the served user is not supported in the network, then the indication of communication diversion to the diverting user for the communication diversion services shall apply.

If the CDIVN service of the served user is supported in the network but has not activated the CDIVN service according to subclause 4.5.1, then the indication of communication diversion to the diverting user for the communication diversion services shall apply.

4.5.2.6.6 not reachable indication

It is recommended that the AS interprets the reception of one of the following response events as not reachable indication:

- 408 Request timeout response;
- 503 Service unavailable;
- 500 Server internal error;

and no provisional response, different than 100 Trying, has been received on the same dialog.

NOTE 1: Once the response code for signalling channel outage between the UE and the P-CSCF is standardized this response has to be added to this list.

NOTE 2: There may be other means to discover this condition. These other means are out of the scope of the present document.

4.5.2.7 Actions at the AS of the diverted to user

The AS shall store the History-Info header of an incoming Request.

If a 180, 181 or 200 response does not contain a History Info header field, the AS shall include the stored History-Info header field and if diverted to user is subscribed to the TIR service the Privacy header field of all responses the priv-value of the last entry in the History-Info header field shall be set to "history".

NOTE: A response including no History-Info header Field is coming from an untrusted entity or the History-Info header field is not included due to the privacy status within the SIP request.

4.5.2.8 Void

4.5.2.9 Actions at the incoming I-CSCF

Procedures according to ES 283 003 [2] shall apply.

4.5.2.10 Actions at the outgoing IBCF

Procedures according to ES 283 003 [2] shall apply.

4.5.2.11 Actions at the incoming IBCF

Procedures according to ES 283 003 [2] shall apply.

4.5.2.12 Actions at the BGCF

Basic call procedures according to ES 283 003 [2] shall apply.

The interworking with other NGN is described in clause 4.7.3.

4.5.2.13 Actions at the MGCF

Procedures according to ES 283 003 [2] shall apply.

The interworking is described in clause 4.7.1.

4.5.2.14 Actions at the destination P-CSCF

Procedures according to ES 283 003 [2] shall apply.

4.5.2.15 Actions at the diverted to UA

Procedures according to ES 283 003 [2] shall apply.

4.5.2.16 Actions at the diverting UA

Procedures according to ES 283 003 [2] shall apply.

To invoke Communication Deflection the UA shall send a 302 including a Contact header field with the address where the communication is diverted to.

4.6 Interaction with other services

4.6.1 Communication Hold (HOLD)

No impact, i.e. neither service shall affect the operation of the other service.

4.6.2 Terminating Identification Presentation (TIP)

A P-Asserted-Identity and History-Info header field received in the diverting AS is passed unmodified to the originating entity. The originating S-CSCF is responsible for the interpretation of the privacy header field.

4.6.3 Terminating Identification Restriction (TIR)

A P-Asserted-Identity and History-Info header field received in the diverting AS is passed unmodified to the originating entity. The originating CSCF is responsible of the interpretation of the privacy header field.

If the served (diverting) user selects the option that the originating user is notified, but without the diverted-to SIP, TEL or SIPS URI, then the AS shall not send the connected user's identity when the communication is answered, unless the originating user has an override capability.

When the TIR simulation service has been invoked by the diverted-to user, the diverted-to user's address and name shall not be presented in the CDIVN notification message.

4.6.4 Originating Identification Presentation (OIP)

When a communication has been diverted and the diverted-to user has been provided with the originating identification presentation simulation service, the S-CSCF of the diverted-to user shall send the SIP, TEL or SIPS URI of the original originating user, if this originating user has not subscribed to or invoked the originating identification restriction simulation service.

4.6.5 Originating Identification Restriction (OIR)

When the originating identification restriction simulation service has been invoked, the originating user's address shall not be presented to the diverted-to user unless the diverted-to user has an override capability.

When the OIR simulation service has been invoked by the originating user, the originating user's address and name shall not be presented in the CDIVN notification message.

4.6.6 Conference calling (CONF)

No impact, i.e. neither service shall affect the operation of the other service.

4.6.7 Communication Diversion Services (CDIV)

For the redirection services, no impact, i.e. neither service shall affect the operation of the other service.

For the CDIVN service and the indication of communication diversion to the diverting user service, the provision and activation of at least one redirection service is a pre-requirement to provision and activate CDIVN service and the indication of communication diversion to the diverting user service.

4.6.8 Malicious Communication Identification (MCID)

No impact, i.e. neither service shall affect the operation of the other service.

4.6.9 Anonymous Communication Rejection and Communication Barring (ACR/CB)

If the user where the communication is forwarded to has subscribed to a call barring service "inhibition of incoming forwarded communication" the procedures described in TS 183 011 [9] shall take precedence.

If the user is subscribed to an Outgoing Communication Barring (OCB) service that includes the forwarded communication the OCB shall take precedence. The CDIV service has to check if the forwarded to SIP, TEL or SIPS URI is restricted and release the communication in such a case.

4.6.10 Explicit Communication Transfer (ECT)

4.6.10.1 Actions at the diverting AS

4.6.10.1.1 Determine whether ECT is applied to the diverted communication

See TS 183 029 [16] clause 4.5.2.4.1 on the criteria that determine that a REFER request is to be treated as a request for transfer of an existing communication.

4.6.10.1.2 Handling of transfer requests

When a REFER request is received in the context of a call transfer scenario (see clause 4.6.10.1.1), it shall perform the following steps:

- 1) Create a new CDIV Session Identifier URI addressed to this AS. The URI shall be created in such a way that a new dialog set up towards this URI can be easily correlated with the current REFER dialog.
- 2) The AS stores the value of the Refer-To header field (transfer target) from the REFER request and links it to the CDIV Session Identifier URI.
- 3) The AS Replaces the Refer-To header field with the CDIV Session Identifier URI. (This ensures that the diverting AS remains in the loop when the transferee sets up the communication with the transfer target.).
- 4) The AS forwards the REFER request to the transferee using basic communication procedures ES 283 003 [2].

4.6.10.1.3 Actions when CDIV is invoked again by the transferred communication

When an INVITE is received targeted at the CDIV Session Identifier URI created earlier when transfer of the diverted ongoing communication was requested, the AS shall perform the following actions:

- 1) The AS replaces the request URI with the stored Refer-To header field value linked to the specific CDIV Session Identifier URI.

NOTE: If needed the AS may generate charging events to charge for the extra leg.

- 2) The AS sets the diversion parameters (History-Info and To header fields) as specified in clause 4.5.2.6.2, in step 4.5.2.6.2.2 b2) or 4.5.2.6.2.3 b2) the cause-param value 302 shall be used.
- 3) The AS forwards the INVITE request towards the transfer target using basic communication procedures ES 283 003 [2].

4.7 Interworking with other networks

4.7.1 Interworking with PSTN/ISDN

In case of interworking with networks which do not provide any notification of the communication diversion or communication redirection information (e.g. redirection counter) in the signalling system, the communication continues according to the basic call procedures.

4.7.1.1 Interworking at the O-MGCF

For the mapping of IAM to the INVITE Message no additional procedures beyond the basic call and interworking procedures are needed unless Call Forwarding within the ISUP network appeared.

With regard to the backward messages the following mapping is valid.

Table 4.7.1.1.1: Mapping of SIP messages to ISUP messages

← Message sent to ISUP	← Message Received from SIP	
ACM indicating call forwarding	181 (Call Is Being Forwarded)	See table 4.7.1.1.6
CPG indicating call forwarding (see note)	181 (Call Is Being Forwarded)	See table 4.7.1.1.7
ACM indicating ringing	180 (Ringing)	See table 4.7.1.1.8
CPG indicating Alerting (see note)	180 (Ringing)	See table 4.7.1.1.9
ANM	200 (OK)	See table 4.7.1.1.10
CON	200 (OK) (Neither a 181 (Call Is Being Forwarded) nor a 180 (Ringing) was received)	See table 4.7.1.1.10
NOTE: A CPG will be sent if an ACM was already send.		

NOTE: The mapping of the basic Messages is shown in ES 283 027 [13].

Table 4.7.1.1.2: Mapping of History-Info Header to ISUP Redirection number

Source SIP header field and component	Source Component value	Redirection number	Derived value of parameter field
Hi-targeted-to-uri of the last History-Info hi-entry containing a cause-param URI parameter, as defined in IETF RFC 4458 [14]. The global number portion of the URI is assumed to be in form "+" CC + NDC + SN. (NOTE)	CC	Nature of address indicator	If CC is equal to the country code of the country where O-MGCF is located AND the next ISUP node is located in the same country, then set to "national (significant) number" else set to "international number".
	CC, NDC, SN	Address signals	If NOA is "national (significant) number" then set to NDC + SN. If NOA is "international number" then set to CC + NDC + SN.
NOTE: If it is SIP URI and doesn't contain "user=phone", mapping to redirection number is impossible, therefore no need to generate Redirection number and Redirection number restriction (per table 4.7.1.1.3). Notification subscription options can't be set as "presentation allowed with redirection number".			

Table 4.7.1.1.3: Mapping of History-Info header to ISUP Redirection number restriction

Source SIP header field and component	Source Component value	Redirection number restriction	Derived value of parameter field
Privacy, priv-value component	"history" or "session" or "header"	Presentation restricted indicator	"Presentation restricted"
	Privacy header field absent or "none"		"Presentation allowed" or absent

Table 4.7.1.1.4: Mapping of hi-targeted-to-uri to ISUP Call Diversion Information

Source SIP header field and component	Source Component value	Call Diversion Information	Derived value of parameter field
Privacy, priv-value component	"history" or "session" or "header"	Notification subscription options	If the priv-value "history" or "session" or "header" is set for the History-Info header or to the hist-info element entries concerning the redirecting (see table 4.7.1.2.2) and diverted to uri (see table 4.7.1.1.2) then <i>presentation not allowed</i> shall be set If the priv-value "history" or "session" or "header" is set only to the hist-info element concerning the diverted-to uri then <i>presentation allowed without redirection number shall be set</i>
	Privacy header field absent or "none"		<i>Presentation allowed with redirection number</i>
hi-targeted-to-uri cause-param URI parameter, as defined in RFC 4458 [14] of the last History-Info hi-entry containing such an a cause-param.	cause-param value	Call diversion information	Redirecting Reason
	404		Unknown
	302		Unconditional
	486		User busy
	408		No reply
	480		Deflection immediate
	503		Mobile subscriber not reachable
	487		Deflection during alerting

Table 4.7.1.1.5: Void

Table 4.7.1.1.6: Mapping of 181 (Call Is Being Forwarded) → ACM if no ACM was sent before

Source SIP header field and component	Source Component value	ISUP Parameter	Derived value of parameter field
181 (Call Is Being Forwarded)		ACM	
		Generic notification indicators	Call is diverting
History-Info Header	See table 4.7.1.1.2	Redirection number	See table 4.7.1.1.2
Priv-value	See table 4.7.1.1.3	Redirection number restriction	See table 4.7.1.1.3
Priv-value	See table 4.7.1.1.4	Call diversion information <i>Notification subscription options</i>	See table 4.7.1.1.4
hi-targeted-to-uri; cause-param URI parameter as defined in IETF RFC 4458[14] of the last History-Info hi-entry containing such an a cause-param.	See table 4.7.1.1.4	Call diversion information	Redirecting Reason See table 4.7.1.1.4

Table 4.7.1.1.7: Mapping of 181 (Call Is Being Forwarded) → CPG if ACM was already sent

Source SIP header field and component	Source Component value	ISUP Parameter	Derived value of parameter field
181 (Call Is Being Forwarded)		CPG	
		Generic notification indicators	Call is diverting
hi-targeted-to-uri; cause-param URI parameter, as defined in IETF RFC 4458 [14] of the last History-Info hi-entry containing such an a cause-param.	486	Event indicator	CFB (national use)
	408 (see note)		CFNR (national use)
	302		CFU (national use)
	Any other value, or if appropriate national use value CFB, CFNR or CFU is not used in a network. or if no agreement exists between operators to use these values, or if no hi-targeted-to-uri cause-param URI parameter is contained in the SIP 181.		PROGRESS
History-Info Header	See table 4.7.1.1.2	Redirection number	See table 4.7.1.1.2
Priv-value	See table 4.7.1.1.3	Redirection number restriction	See table 4.7.1.1.3
Priv-value	See table 4.7.1.1.4	Call diversion information <i>Notification subscription options</i>	See table 4.7.1.1.4
hi-targeted-to-uri; cause-param URI parameter, as defined in RFC 4458 [14]	See table 4.7.1.1.4	Call diversion information <i>Redirecting Reason</i>	See table 4.7.1.1.4
NOTE: This appears in the cases of CFNR.			

Table 4.7.1.1.8: Mapping of 180 (Ringing) → ACM if no ACM was sent before

Source SIP header field and component	Source Component value	ISUP Parameter	Derived value of parameter field
180 (Ringing)		ACM	
History Header	If hi-targeted-to-uri of at least one History-Info hi-entry contains a cause-param URI parameter, as defined in IETF RFC 4458 [113].	Generic notification indicators	Call is diverting
History Header	See table 4.7.1.1.2	Redirection number (NOTE)	See table 4.7.1.1.2
Priv-value	See table 4.7.1.1.3	Redirection number restriction (NOTE)	See table 4.7.1.1.3
Priv-value	See table 4.7.1.1.4	Call diversion information <i>Notification subscription options</i> (NOTE)	See table 4.7.1.1.4
hi-targeted-to-uri; cause-param URI parameter, as defined in IETF RFC 4458 [14] of the last History-Info hi-entry containing such an a cause-param.	See table 4.7.1.1.4	Call diversion information <i>Redirecting Reason</i> (NOTE)	See table 4.7.1.1.4
NOTE: Parameter shall only be supplied if hi-targeted-to-uri of at least one History-Info hi-entry contains a cause-param URI parameter, as defined in IETF RFC 4458 [113].			

The mapping described within table 4.7.1.1.1 can only appear if the communication has already undergone a Call Forwarding in the ISDN/PSTN and the 180 is the first provisional response sent in backward direction.

The IWU can indicate the call diversion in the mapping of 180 (Ringing) to CPG in fact if the response before was a 181 (Call Is Being Forwarded).

Table 4.7.1.1.9: Mapping of 180 (Ringing) → CPG if ACM was already sent

Source SIP header field and component	Source Component value	ISUP Parameter	Derived value of parameter field
180 (Ringing)		CPG	
History-Info header field	If hi-targeted-to-uri of at least one History-Info hi-entry contains a cause-param URI parameter, as defined in IETF RFC 4458 [113].	Generic notification indicators	Call is diverting
		Event indicator	ALERTING
History Header	See table 4.7.1.1.2	Redirection number (NOTE)	See table 4.7.1.1.2
Priv-value	See table 4.7.1.1.3	Redirection number restriction (NOTE)	See table 4.7.1.1.3
Priv-value	See table 4.7.1.1.4	Call diversion information <i>Notification subscription options</i> (NOTE)	See table 4.7.1.1.4
hi-targeted-to-uri; cause-param URI parameter, as defined in IETF RFC 4458 [14] of the last History-Info hi-entry containing such an a cause-param.	See table 4.7.1.1.4	Call diversion information <i>Redirecting Reason</i> (NOTE)	See table 4.7.1.1.4
NOTE: Parameter shall only be supplied if hi-targeted-to-uri of at least one History-Info hi-entry contains a cause-param URI parameter, as defined in IETF RFC 4458 [113].			

The mapping in table 4.7.1.1.9 appears when a 181 previously was mapped to an ACM. Therefore the statemachine of the MGCF knows that a CDIV is in Progress.

Table 4.7.1.1.10: Mapping of 200 (OK) response

Source SIP header field and component	Source Component value	ISUP Parameter	Derived value of parameter field
200 (OK) response		ANM/CON	
History-Info Header	See table 4.7.1.1.2	Redirection number	See table 4.7.1.1.2
Priv-value	See table 4.7.1.1.3	Redirection number restriction	See table 4.7.1.1.3

4.7.1.1.1 Void

4.7.1.1.2 Call forwarding within the ISUP Network appeared

The following Scenario shows if a Call Forwarding appears in the ISUP/PSTN Network and the redirected Number is within the SIP Network. Table 4.7.1.1.2.1 should be seen as example.

For the mapping of 180 (Ringing) and 200 (OK) response OK to the regarding ISUP messages and parameters no additional procedures beyond the basic call procedures are needed.

To interwork the redirection number at the O-MGCF it can be needed to create placeholder History entries. Such a History entry has to provide a hi-target-to-uri with a placeholder value "unknown@unknown.invalid" a cause-param and a index as described within table 4.7.1.1.2.1.

Table 4.7.1.1.2.1: Mapping of IAM to SIP INVITE

ISUP Parameter or IE	Derived value of parameter field	SIP component	Value
IAM		INVITE	
Redirecting number		History Header	hi-targeted-to-uri of the penultimate created hi-entry IF Redirection counter exceeds 1 ELSE no mapping
Nature of address indicator:	"national (significant) number"	hi-targeted-to-uri	Add CC (of the country where the MGCF is located) to Generic Number Address Signals then map to user portion of URI scheme used. Addr-spec "+" CC NDC SN mapped to user portion of URI scheme used
	"international number"		Map complete Redirection number Address Signals to user portion of URI scheme used.
Address Signals	If NOA is "national (significant) number" then the format of the Address Signals is: NDC + SN If NOA is "international number" then the format of the Address Signals is: CC + NDC + SN	hi-targeted-to-uri	"+" CC NDC SN mapped to userinfo portion of URI scheme used
Redirecting number	APRI	Privacy Header that corresponds to the penultimate hi-targeted-to-uri entry in the History-Info header	Priv-value
	"presentation restricted"		"History"
	"presentation allowed"		Privacy header field absent or "none" (NOTE 3)
Redirection Information	Redirecting indicator	Privacy Header that corresponds to the penultimate hi-targeted-to-uri entry in the History-Info header	Priv-value
	Call diverted		"none" (NOTE 4)
	Call diverted, all redirection info presentation restricted		"History"

ISUP Parameter or IE	Derived value of parameter field	SIP component	Value
Redirection Information	Redirection counter 1	History Index	Number of diversions are shown due to the number of Index Entries Index for original called Party Number = 1 Address Signals (CdPN) Number = 1.1
	2		Index for original called Party Number = 1 Index for Redirecting number with Index = 1.1 Address Signals (CdPN) Number = 1.1.1
	N		Index for original called Party Number = 1 Placeholder History entry with Index = 1.1 ... Fill up ... Index for Redirecting Number with = 1+[(N-1)*".1"] Index for Address Signals (CdPN) = 1+N* ".1" (e.g. N=3 → 1.1.1.1)
Redirection Information	Redirecting Reason and Original Redirection Reason (NOTE 1)	hi-targeted-to-uri; cause-param URI parameter, as defined in IETF RFC 4458 [14] . The Redirecting Reason shall be mapped to the last hi-targeted-to-uri. If the redirection counter is 2 or higher, the Original Redirection Reason shall be mapped to the second hi-targeted-to-uri. If the redirection counter is 3 or higher, for each hi-targeted-to-uri following a placeholder History entry the value "404" shall be taken (NOTE 2)	Cause value
	unknown		404
	unconditional		302
	User Busy		486
	No reply		408
	Deflection during alerting		487
	Deflection immediate response		480
	Mobile subscriber not reachable		503
Called Party Number	See Redirecting number	History Header see hi-targeted-to-uri	URI of the last hi-targeted-to-uri entry of History Header
Original Called Party Number	See Redirecting number	History Header see hi-targeted-to-uri	URI of first hi-targeted-to-uri entry of History Header
Original Called Party Number	APRI	Privacy Header	Priv-value
	"presentation restricted"		"history"
	"presentation allowed"		"none"
NOTE 1: Original Redirection Reason contains only the "unknown" parameter.			
NOTE 2: For all History entries except the first one a cause-param URI parameter as defined in RFC 4458 [14] has to be included.			
NOTE 3: If the Redirecting Indicator has the value "Call diverted, all redirection info presentation restricted", the privacy value "history" shall be set.			
NOTE 4: If the Redirecting Number APRI has the value "presentation restricted", the privacy value "history" shall be set.			

4.7.1.2 Interworking at the I-MGCF

Table 4.7.1.2.1: Mapping of SIP to ISUP messages

→ Message received from SIP	→ Message send to BICC/ISUP
INVITE	IAM

Table 4.7.1.2.2: Mapping of History-Info Header to ISUP Redirecting number

Source SIP header field and component	Source Component value	Redirecting number	Derived value of parameter field
In History-Info SIP header field, hi-targeted-to-uri in hi-entry before last hi-entry containing a cause-param URI parameter as defined in IETF RFC 4458 [14] (NOTE 1)		Redirecting number	
Hi-target-to-uri appropriate global number portion of the URI, assumed to be in form "+" CC + NDC + SN	CC	Nature of address indicator	If CC is equal to the country code of the country where MGCF is located AND the next ISUP node is located in the same country, then set to "national (significant) number" else set to "international number"
	CC, NDC, SN	Address signals	If NOA is "national (significant) number" then set to NDC + SN. If NOA is "international number" then set to CC + NDC + SN
Privacy Header , priv-value component In History-Info header field as specified in this table (NOTE 2)	"history" or "session" or "header"	APRI	"presentation restricted"
	Privacy header field absent or "none"		"presentation allowed"
NOTE 1: If it is SIP URI and doesn't contain "user=phone", mapping to redirecting number is impossible, therefore no need to generate Redirecting number.			
NOTE 2: It is possible that an entry of the In History-Info header field itself is marked as restricted or the whole History header.			

Table 4.7.1.2.3: Mapping of History-Info Header to ISUP Redirection Information

Source SIP header field and component	Source Component value	Redirection Information	Derived value of parameter field
Privacy header field and priv-value of hi-entry before the last hi-entry containing a cause-param URI parameter as defined in IETF RFC 4458 [14] of the History Info header field.	"history" or "session" or "header" for the Privacy header field or for the hi-targeted-to-uri entry	Redirecting indicator	Call diverted, all redirection info presentation restricted
	Privacy header field and the privacy component of the hi-targeted-to-uri entry either absent or "none"		Call diverted
		Original redirection reason	Unknown
Cause-param value in the last hi-targeted-to-uri containing a cause-param URI parameter, as defined in IETF RFC 4458 [14]	cause-param value	Redirecting Reason	Redirecting Reason
	404		Unknown/not available
	302		Unconditional
	486		User busy
	408		No reply
	480		Deflection immediate response
	487		Deflection during alerting
	503		Mobile subscriber not reachable
Hi-index		Redirection counter	number of History entries containing a cause-param with cause as listed in the cause-param row in this table

Table 4.7.1.2.4: Mapping of History-Info Header to ISUP Original Called number

Source SIP header field and component	Source Component value	Original called number	Derived value of parameter field
		Numbering Plan Indicator	"ISDN (Telephony) numbering plan (Recommendation E.164)"
Hi-target-to-uri of hi-entry preceding the 1 st hi-targeted-to-uri containing a cause-param URI parameter, as defined in IETF RFC 4458 [14]; the global number portion of the URI is assumed to be in form "+" CC + NDC + SN (NOTE 2)	CC	Nature of address indicator	If CC is equal to the country code of the country where MGCF is located AND the next ISUP node is located in the same country, then set to "national (significant) number" else set to "international number"
	CC, NDC, SN	Address signals	If NOA is "national (significant) number" then set to NDC + SN. If NOA is "international number" then set to CC + NDC + SN
priv-value component in History-Info header field of the History-Info header field entry as defined above in this table (Note 1)	"history" or "session" or "header"	APRI	"presentation restricted"
	Privacy header field absent or "none"		"presentation allowed"
NOTE 1: It is possible that an entry of the History-Info header field itself is marked as restricted or the whole History-Info header.			
NOTE 2: If it is SIP URI and doesn't contain "user=phone", mapping to Original Called number is impossible, therefore no need to generate Original Called number.			

Table 4.7.1.2.5: Mapping of INVITE to IAM

INVITE		IAM	
History Header	See table 4.7.1.2.2	Redirecting number	See table 4.7.1.2.2
History-Info Header	See table 4.7.1.2.3	Redirection Information	See table 4.7.1.2.3
cause-param in the last hi-targeted-to-uri containing a cause-param as defined in IETF RFC 4458 [14]cause-param	cause-param value	Redirection Information	Redirecting Reason
	404		Unknown/not available
	302		Unconditional
	486		User busy
	408		No reply
	480		Deflection immediate response
	487		Deflection during alerting
503	Mobile subscriber not reachable		
History-Info header field	See table 4.7.1.2.4	Original Called Number	See table 4.7.1.2.4

Table 4.7.1.2.6: Mapping of ISUP to SIP Messages

← Message sent to SIP	← Message Received from BICC/ISUP	
181 (Being forwarded)	ACM no indication with Redirection number and call diversion information (CFU, CFB, CDi)	See table 4.7.1.2.8
180 (Ringing)	ACM indicating ringing, oBCi: Call diversion may occur (CFNR, CDa)	Basic call procedure as described within ES 283 027 [13]
181 (Being forwarded)	CPG indicating progress or subsequent diversion indicated in the CPG with Redirection number and call diversion information (CFNR, CDa)	See table 4.7.1.2.9
180 (Ringing)	CPG indicating ringing and Redirection number restriction parameter	See table 4.7.1.2.10
200 (OK)	ANM and Redirection number restriction parameter	See table 4.7.1.2.11

In the ISUP destination Exchange of the diverted-to user (see EN 300 356-15 [10]) only the Redirection Number Restriction parameter will be included into the ACM, CPG, ANM or CON message. Therefore only the mapping of this parameter is shown in the following table.

Table 4.7.1.2.7: Mapping of ISUP Redirection Number Restriction to History-Info header field

Redirection Number Restriction	Derived value of parameter field	SIP component	Value
Presentation restricted indicator	"Presentation restricted"		"History"
	"Presentation allowed" or absent AND any previous received notification subscription option was NOT "presentation not allowed" OR was NOT "presentation allowed without redirection number"		Privacy header field absent or "none"

A received CPG shall be mapped to a 180 (Ringing) if the CPC indicates a Alerting is due to the mapping rules defined within the basic call.

Table 4.7.1.2.8: Mapping of ACM → 181 (Call Is Being Forwarded)

ISUP Parameter	Derived value of parameter field	SIP component	Value
Generic notification indicators	Call is diverting		
Redirection number		History-Info Header with one hi-entry	hi-targeted-to-uri:
Nature of address indicator:	" <i>national (significant) number</i> "	hi-targeted-to-uri	Add CC (of the country where the MGCF is located) to Redirection number Address Signals then map to user portion of URI scheme used. Addr-spec "+" CC NDC SN mapped to user portion of URI scheme used according to the rules of clause 4.5.2.6.4 item c
	" <i>international number</i> "		Map complete Redirection number Address Signals to user portion of URI scheme used according to the rules of clause 4.5.2.6.4 item c
Address Signals	If NOA is " <i>national (significant) number</i> " then the format of the Address Signals is: NDC + SN If NOA is " <i>international number</i> " then the format of the Address Signals is: CC + NDC + SN	hi-targeted-to-uri	"+" CC NDC SN mapped to userinfo portion of URI scheme used
Call diversion information	<i>Redirecting Reason</i>	IETF RFC 4458 [14] cause-param URI parameter hi-targeted-to-uri entry (NOTE)	cause-param value
	Unknown/not available		404
	Unconditional		302
	User busy		486
	No reply		408
	Deflection immediate response		480
	Deflection during alerting		487
	Mobile subscriber not reachable		503
	<i>Notification subscription option</i> unknown	Privacy	Roles
	presentation not allowed		Escaped Privacy value is set according to the rules of clause 4.5.2.6.4 item c A 181 Being Forwarded shall not be sent
	presentation allowed with redirection number		Escaped Privacy value is set according to the rules of clause 4.5.2.6.4 item c
	presentation allowed without redirection number		Escaped Privacy value is set according to the rules of clause 4.5.2.6.4 item c
NOTE: Needs to be stored for a possible inclusion into subsequent messages.			

Table 4.7.1.2.9: Mapping of CPG → 181 (Call Is Being Forwarded)

ISUP Parameter	Derived value of parameter field	SIP component	Value
Event Indicator	Progress		
Generic notification indicators	Call is diverting		
Redirection number		History-Info Header	hi-targeted-to-uri:
Nature of address indicator	" <i>national (significant) number</i> "	hi-targeted-to-uri field with one hi-entry	Add CC (of the country where the MGCF is located) to Redirection number Address Signals then map to user portion of URI scheme used. Addr-spec "+" CC NDC SN mapped to user portion of URI scheme used according to the rules of clause 4.5.2.6.4 item c
	" <i>international number</i> "	hi-targeted-to-uri	Map complete Redirection number Address Signals to user portion of URI scheme used according to the rules of clause 4.5.2.6.4 item c
Address Signals	If NOA is " <i>national (significant) number</i> " then the format of the Address Signals is: NDC + SN If NOA is " <i>international number</i> " then the format of the Address Signals is: CC + NDC + SN	hi-targeted-to-uri	"+" CC NDC SN mapped to userinfo portion of URI scheme used
Call diversion information	<i>Redirecting Reason</i>	IETF RFC 4458 [14] cause-param in the hi-targeted-to-uri (NOTE)	cause param value
	Unknown/not available		404
	Unconditional		302
	User busy		486
	No reply		408
	Deflection immediate response		480
	Deflection during alerting		487
	Mobile subscriber not reachable		503
	<i>Notification subscription option</i>		Privacy
	unknown	Escaped Privacy value is set according to the rules of clause 4.5.2.6.4 item c	
presentation not allowed	A 181 Being Forwarded shall not be sent		
presentation allowed with redirection number	Escaped Privacy value is set according to the rules of clause 4.5.2.6.4 item c		
presentation allowed without redirection number		Escaped Privacy value is set according to the rules of clause 4.5.2.6.4 item c	
NOTE: Needs to be stored for a possible inclusion into subsequent messages.			

Table 4.7.1.2.10: Mapping of CPG → 180 (Ringing)

ISUP Parameter	Derived value of parameter field	SIP component	Value
Event Indicator	Alerting		
Redirection number		History-Info Header with one hi-entry	See table 4.7.1.2.8
		RFC 4458 [14] cause-param in the hi-targeted-to-uri	Value stored from a previous received ACM or CPG. See table 4.7.1.2.8 and 4.7.1.2.9.
Redirection number restriction			See table 4.7.1.2.7

Table 4.7.1.2.11: Mapping of ANM → 200 OK (INVITE)

ISUP Parameter	Derived value of parameter field	SIP component	Value
Redirection number		History-Info Header with one hi-entry	See table 4.7.1.2.8
		RFC 4458 [14] cause-param URI parameter in the hi-targeted-to-uri	cause value= as stored from a previous received the ACM or CPG. See tables 4.7.1.2.8 and 4.7.1.2.9.
Redirection number restriction			See table 4.7.1.2.7

4.7.2 Interworking with PSTN/ISDN Emulation

The Interworking with PSTN/ISDN Emulation is for further study.

4.7.3 Interworking with external IP networks

For SIP based networks the-procedures used shall be compliant with ES 283 003 [2].

The interworking with non SIP networks is for further study.

4.8 Parameter values (timers)

4.8.1 No reply timer

No reply timer: Timer duration shall be a service provider option.

4.8.2 CDIVN Buffer Timer

CDIVN Buffer Timer: operator's option (default = 86 400 sec), may be overwritten by the user in the SUBSCRIBE message-Notification Buffer Interval.

Notification Buffer Interval: 0 sec - 86 400 sec.

4.8.3 CDIV Indication Timer

$T_{\text{CDIV_IND}}$ 60 sec - 00 sec.

The timer is started when the diverting user is registering to the communication system. Based on operator policy the user has the possibility to choose a certain timer value within the defined range.

4.9 Service Configuration for redirection services

4.9.1 Structure of the XML Document

Communication Diversion documents are subtrees of the *simservs* document specified in TS 183 023 [4]. As such, Communication Diversion documents use the XCAP application usage in TS 183 023 [4].

In addition to the considerations and constraints defined by the *simservs* document TS 183 023 [4], we define the additional constraints and considerations for the Communication Diversion subtree:

XML schema: Implementations in compliance with the present document shall implement the XML schema that minimally includes the XML Schema defined in clause 4.9.2 and the *simservs* XML schema specified in clause 6.3 of TS 183 023 [4].

Data semantics: The semantics of the communication diversion XML configuration document is specified in clause 4.9.1.

An instance of the simulation services configuration containing a communication diversion configuration document.

```
<?xml version="1.0" encoding="UTF-8"?>
<simservs
  xmlns= http://uri.etsi.org/ngn/params/xml/simservs/xcap
  xmlns:cp="urn:ietf:params:xml:ns:common-policy"
  xmlns:ocp="urn:oma:xml:xdm:common-policy">
  <communication-diversion active="true">
    rule set
  </communication-diversion>
</simservs>
```

The communication diversion service contains a rule set that specifies how the communication diversion service shall react to external stimuli.

4.9.1.1 Communication Diversion Element

The communication diversion configuration contains a `noReplyTimer` element, a rule set, or a `noReplyTimer` element followed by a rule set. The rule set reuses the syntax as specified by the common policy draft (see RFC 4745 [18]).

```
<communication-diversion active="true">
  <NoReplyTimer>NoReplyTimerValue</NoReplyTimer>
  <cp:ruleset>
    rule1
    rule2
  </cp:ruleset>
</communication-diversion>
```

In general the following procedure applies:

When the service processes a set of rules it shall start executing the first rule. If:

- the rule has no `<conditions>` element;
- the rule has an empty `<conditions>` element; or
- conditions are present and they all evaluate to true;

then the rule matches and the specified action shall be executed.

When the rule does not match the following rule shall be selected and the same procedure repeated, until a matching rule is found or the set of remaining rules is empty.

However not all rules can be matched at the same moment in the call. Some conditions imply that rules that carry them are checked at specific events in the call, for example the no-answer condition only holds when the called party does not answer after a while. In this case the same procedure shall apply as above with the modification that the set of rules to process contains only the rules applicable for that specific network event.

In clause 4.9.1.3 all allowed conditions are specified, normally rules are evaluated at communication setup time, for conditions where this is not the case this is explicitly indicated.

The shown "active" attribute is inherited from the `simservType` from TS 183 023 [4], its meaning is also specified in TS 183 023 [4].

4.9.1.1A NoReplyTimer

NoReplyTimer: An optional element that covers the time to elapse until the communication diversion shall perform, if the served user does not answer when alerted.

4.9.1.2 Communication Diversion Rules

The Communication Diversion service is configured with an ordered set of forwarding rules. The XML Schema reuses the rule syntax as specified by the common policy draft (see RFC 4745 [18]). The rules take the following form:

```

<cp:rule id="rule66">
  <cp:conditions>
    condition1
    condition2
  </cp:conditions>
  <cp:actions>
    <forward-to>
      <target>
targetAddress1
      </target>
      <notify-caller>true</notify-caller>
    </forward-to>
  </cp:actions>
</cp:rule>

```

When the service processes a set of rules it shall start executing the first rule. If:

- the rule has no `<conditions>` element;
- the rule has an empty `<conditions>` element; or
- conditions are present and they all evaluate to true;

then the rule matches and the specified action is executed. When a rule matches remaining rules in the rule set shall be discarded. Applied to the fragment above this means that only if the expression (*condition1* AND *condition2*) evaluates to true that then the *rule66* matches and the forward-to action is executed.

When the rule does not match the following rule shall be selected and the same procedure repeated, until a matching rule is found or the set of remaining rules is empty.

The "id" attribute value of a rule shall uniquely identify the rule within a rule set. This can be used in XCAP usage to address one specific rule.

4.9.1.3 Communication Diversion Rule Conditions

The following conditions are allowed by the XML Schema for the communication diversion service:

busy: This condition evaluates to true when the called user is busy. In all other cases the condition evaluates to false. Rules with this condition are evaluated when a busy indication is received from the called party.

not-registered: This condition evaluates to true when the called user is not registered. In all other cases the condition evaluates to false.

presence-status: This condition evaluates to true when the called user's current presence activity status is equal to the value set for this condition. In all other cases the condition evaluates to false.

cp:identity: This condition evaluates to true when the *calling* user's identity matches with the value of the identity element. The interpretation of all the elements of this condition is described in OMA-TS-XDM-Core-V1_1 [20]. In all other cases the condition evaluates to false. The Identity shall be matched against the value taken from the P-Asserted-Identity header field, unless both the <identity> element value and the Contact header field value contain a "gr" parameter, then the <identity> element value shall be matched against the value taken from the Contact header field.

anonymous: This condition evaluates to true when the P-Asserted-Identity of the calling user is not provided or privacy restricted.

cp:sphere: Not applicable in the context of the Communication Diversion service.

cp:validity: Specifies a period. The condition evaluates to true when the current time is within the validity period expressed by the value of this condition. In all other cases the condition evaluates to false.

media: When the incoming call request for certain media, the forwarding rule can decide to forward the call for this specific media. This condition evaluates to true when the value of this condition matches the media field in one of the "m=" lines in the SDP (RFC 2327 [5]) offered in an INVITE (RFC 3261 [6]).

no-answer: This condition evaluates to true when the called user does not answer. In all other cases the condition evaluates to false. Rules with this condition are evaluated when a no-answer timeout is detected.

rule-deactivated: This condition always evaluates to false. This can be used to deactivate a rule, without losing information. By removing this condition the rule can be activated again.

ocp:external-list: This condition evaluates to true when the calling users identity is contained in an external resource list to which the value of external-list refers. The exact interpretation of this element is specified in OMA-TS-XDM-Core-V1_1 [20] (see bibliography).

ocp:other-identity: Not applicable in the context of communication diversion service.

not-reachable: This condition evaluates to true when there is a signalling channel outage during session setup to the served user's UE and the served user is registered. In all other cases this condition evaluates to false.

NOTE: As described in RFC 4745 [18] the case of unconditional evaluates to be true in all cases where all other reasons are not applicable. A communication diversion is performed as soon as the served user is the called user. The indication of unconditional is the absence of any reason element in the ss:condition element.

The condition elements that are not taken from the common policy schema (see RFC 4745 [18]) or oma common policy schema (see OMA-TS-XDM-Core-V1_1 [20] in bibliography) are defined in the sirmservs document schema specified in 3GPP TS 183 023 [4].

4.9.1.4 Communication Diversion Rule Actions

The action supported by the communication service is forwarding of calls. For this the forward-to action has been defined. The forward-to action takes the following elements:

target: Specifies the address of the forwarding rule. It should be a SIP URI or SIPS (RFC 3261 [6]), TEL URL (RFC 3966 [7]).

notify-caller: An optional element that can be used to disable the default behaviour that the caller is notified that the call is being forwarded (see subscription option "*Originating* user receives notification that his communication has been diverted (forwarded or deflected)" in table 4.3.1.1).

reveal-served-user-identity-to-caller: An optional element that can be used to disable the default behaviour that the caller, when notified that the call is being forwarded, receives the *diverting* party's identity information (see subscription option "Served user allows the presentation of his/her URI to *originating* user in diversion notification" in table 4.3.1.1).

reveal-identity-to-caller: An optional element that can be used to disable the default behaviour that the caller, when notified that the call is being forwarded, receives some diverted-to party's identity information (see subscription option "Served user allows the presentation of forwarded to URI to *originating* user in diversion notification" in table 4.3.1.1).

notify-served-user: An optional element that can be used to enable that the served user is indicated that calls are being forwarded. Default this is switched off (see subscription option "Served user receives notification that a communication has been forwarded" in table 4.3.1.1).

notify-served-user-on-outbound-call: An optional element that can be used to enable that the served user is notified that calls are being forwarded when he makes a call attempt. Default this is switched off (see subscription option "Served user receives reminder notification on outgoing communication that forwarding is currently activated" in table 4.3.1.1).

reveal-identity-to-target: An optional element that can be used to disable the default behaviour that the diverted-to party receives some identity information of the diverting party (see subscription option "Served user allows the presentation of his/her URI to *diverted-to* user" in table 4.3.1.1).

4.9.2 XML Schema

```
<?xml version="1.0" encoding="UTF-8"?>
<xs:schema xmlns:xs="http://www.w3.org/2001/XMLSchema"
  xmlns:ss="http://uri.etsi.org/ngn/params/xml/simservs/xcap"
  xmlns:cp="urn:ietf:params:xml:ns:common-policy"
  xmlns:ocp="urn:oma:xml:xdm:common-policy"
  targetNamespace="http://uri.etsi.org/ngn/params/xml/simservs/xcap"
  elementFormDefault="qualified"
  attributeFormDefault="unqualified">
  <!-- import common policy definitions -->
  <xs:import namespace="urn:ietf:params:xml:ns:common-policy" schemaLocation="common-policy.xsd"/>
  <!-- import OMA common policy extensions -->
  <xs:import namespace="urn:oma:xml:xdm:common-policy" schemaLocation="OMA-SUP-
XSD_xdm_commonPolicy-V1_0_2-20070830-A.xsd"/>
  <!-- communication diversion specific extensions to IETF common policy conditions. The
cp:conditionsType is expanded with the elements: ss:not-registered, ss:busy, ss:no-answer, ss:not-
reachable, ss:media as optional elements -->
  <!-- communication diversion rule set based on the common policy rule set.-->
  <xs:element name="communication-diversion" substitutionGroup="ss:absService">
    <xs:annotation>
      <xs:documentation>This is the communication diversion configuration
document.</xs:documentation>
    </xs:annotation>
    <xs:complexType>
      <xs:complexContent>
        <xs:extension base="ss:simservType">
          <xs:sequence>
            <!-- add service specific elements here-->
            <xs:element ref="ss:NoReplyTimer" minOccurs="0"/>
            <xs:element ref="cp:ruleset" minOccurs="0"/>
          </xs:sequence>
        </xs:extension>
        <!-- service specific attributes can be defined here -->
      </xs:complexContent>
    </xs:complexType>
  </xs:element>

  <!-- communication diversion specific extensions to IETF common policy actions-->
  <xs:element name="forward-to" type="ss:forward-to-type" />
  <xs:simpleType name="reveal-URI-
options-type">
    <xs:restriction base="xs:string">
      <xs:enumeration value="false"/>
      <xs:enumeration value="not-reveal-GRUU"/>
      <xs:enumeration value="true"/>
    </xs:restriction>
  </xs:simpleType>
  <!-- communication diversion specific type declarations -->
  <xs:complexType name="forward-to-type">
    <xs:sequence>
      <xs:element name="target" type="xs:anyURI" minOccurs="1" maxOccurs="1"/>
      <xs:element name="notify-caller" type="xs:boolean" default="true" minOccurs="0"/>
      <xs:element name="reveal-identity-to-caller" type="ss:reveal-URI-options-type"
default="true" minOccurs="0"/>
      <xs:element name="reveal-served-user-identity-to-caller" type="ss:reveal-URI-options-
type" default="true" minOccurs="0"/>
      <xs:element name="notify-served-user" type="xs:boolean" default="false" minOccurs="0"/>
      <xs:element name="notify-served-user-on-outbound-call" type="xs:boolean" default="false"
minOccurs="0"/>
      <xs:element name="reveal-identity-to-target" type="ss:reveal-URI-options-type"
default="true" minOccurs="0"/>
    </xs:sequence>
  </xs:complexType>
</xs:schema>
```

```

    </xs:sequence>
  </xs:complexType>
  <xs:element name="NoReplyTimer">
    <xs:simpleType>
      <xs:restriction base="xs:positiveInteger">
        <xs:minInclusive value="5"/>
        <xs:maxInclusive value="180"/>
      </xs:restriction>
    </xs:simpleType>
  </xs:element>
</xs:schema>

```

4.10 Service Configuration of Communication Diversion Notification

4.10.1 Structure of the XML Document

Communication Diversion Notification documents are used for subscribing to the CDIVN service as well as for receiving the notification information about the various communication diversions.

An instance of the communication diversion notification subscription document is shown below.

```

<comm-div-info>
  <comm-div-sub-info>
    <comm-div-selection-criteria>
      <originating-user-selection-criteria>
        <user-info>
          <user-name>Boss</originating-user-name>
          <user-uri>
            sip:boss@office.com
          </user-uri>
        </user-info>
      </originating-user-selection-criteria>
      <diversion-time-selection-criteria>
        <time-range>
          <start-time>1999-05-31T13:20:00-05:00</start-time>
          <end-time>2006-05-06T13:20:00-05:00</end-time>
        </time-range>
      </diversion-time-selection-criteria>
      <diversion-reason-selection-criteria>
        <diversion-reason-info>404</diversion-reason-info>
      </diversion-reason-selection-criteria>
    </comm-div-selection-criteria>
    <comm-div-ntfy-trigger-criteria>
      <notification-time-selection-criteria>
        <time-range>
          <start-time>1999-05-31T13:20:00-05:00</start-time>
          <end-time>2006-05-06T13:20:00-05:00</end-time>
        </time-range>
      </notification-time-selection-criteria>
    </comm-div-ntfy-trigger-criteria>
  </comm-div-sub-info>
</comm-div-info>

```

Communication Diversion Notification documents have the following structure.

```

<comm-div-info>
  <comm-div-ntfy-info>
    <originating-user-info>
      <user-name>Boss</user-name>
      <user-uri>sip:boss@office.com</user-uri>
    </originating-user-info>
    <diverting-user-info>
      sip:alice@office.com
    </diverting-user-info>
    <diverted-to-user-info>
      sip:bob@office.com
    </diverted-to-user-info>
    <diversion-time-info>1999-06-01T13:20:00-05:00</diversion-time-info>
    <diversion-reason-info>404</diversion-reason-info>
    <previous-cdivn-state>IDLE</previous-cdivn-state>
  </comm-div-ntfy-info>

```

</comm-div-info>

4.10.1.1 Communication Diversion Information

The Communication Diversion Information serves two purposes:

- in the SUBSCRIBE method, it carries the filter criteria for selecting specific communication diversions of the user which should be notified;
- selecting the information about the Communication Diversion, which has to be notified to the user in the corresponding NOTIFY method.

4.10.1.1.1 Communication Diversion Subscription Information

The Communication Diversion Subscription Information allows the user to specify various filter criteria for selecting and controlling the amount of information in the notification of his/her communication diversion. This element has the following sub-elements.

4.10.1.1.1.1 Communication Diversion Selection Criteria

The user would be able to select a specific subset of the overall communication diversions for notification. This helps the user to focus only on those communication diversions which may be important (e.g. "let me know whenever calls from my boss get diverted"). The user is able to set the following criteria for selecting the communication diversions which have to be notified.

- 1) Identity of the Originating party:
The URI specified over here will be compared with the URI (Identity) of the Originating party in the incoming communication. Only if there is a match, then information about the diversion of this specific communication would be selected for notification to the Diverting user. This is an optional parameter. If absent, then all diversions for communications from any Originating party would be considered for notification, subject to other filter criteria.
- 2) Identity of the Diverting party:
The URI specified over here will be compared with the Request-URI of the Diverting user, for which a communication has been diverted. Only if there is a match, then information about this specific communication diversion would be notified to the subscribing user. This is an optional parameter. If absent, then communication diversions towards all registered contacts of the subscribing user would be considered for notification, subject to other filter criteria.
- 3) Identity of the Diverted-To party:
The URI specified over here will be compared with the URI of the Diverted-to party, to whom the communication has been diverted. Only if there is a match, then information about this specific communication diversion would be notified to the subscribing user. This is an optional parameter. If absent, then communication diversions towards any Diverted-To party would be considered for notification, subject to other filter criteria.
- 4) Time-Range of the Communication Diversion:
This specifies a time-range, within which all communication diversions would be notified to the subscribing user. If present, then any communication diversion outside of this time-range would NOT be notified to the Diverting user. This is an optional parameter. If absent, then Communication Diversions happening at any time would be considered for notification, subject to other filter criteria. A time zone should be indicated. If a time zone is not indicated the SUBSCRIBE shall be rejected with a SIP 489.
- 5) Reason for the Communication Diversion:
The Diverting user can select that only those communication diversions which match the herein specified reasons be notified (see annex C). This is an optional parameter. If absent, then all communication diversions resulting due to any reason would be considered for notification, subject to other filter criteria.

4.10.1.1.1.2 Communication Diversion Notification Trigger Criteria

As a part of the SUBSCRIBE message body, the user may specify further criteria to trigger the notification of those communication diversions, which were selected by the above mentioned criteria. These criteria enable the user to trigger the notification based on the following;

- **Time-Range:**
This specifies a time-range at which notifications of communication diversion can be sent to the user. It may be specified in the form of a time-interval to enable periodic triggering of notifications of communication diversions which took place in that time-interval. If absent, it indicates that notifications are sent immediately when the communication diversion takes place. A time zone should be indicated. If a time zone is not indicated the SUBSCRIBE shall be rejected with a SIP 489.
- **Presence-status:**
This specifies a presence state of the user, within which the user expects to receive notifications about communication diversions. If absent, it indicates that notifications are sent immediately irrespective of user's availability information.

In addition, the user may overwrite the CDIVN Buffer Timer with the Notification Buffer Interval as part of the SUBSCRIBE message body. The Buffer Interval value is time up to which the CDIVN AS should buffer the notification if it cannot be delivered to the user at the time of CDIVN AS execution. The user will be notified if CDIVN activation is valid and the CDIVN Buffer Timer to provide the notification has not expired, as described in clause 4.2.1.

- **Notification Buffer Interval:**
This specifies an optional element (in seconds) to overwrite the CDIVN Buffer Timer for which the CDIVN AS should store the CDIV Notification, if it cannot be delivered to the user, as per the criteria configured above. For example this would be required for buffering the notifications, if the user is logged out and the diversion is triggered due to CFNL/CFNRc, resulting in CDIVN for that diversion. The user may set Notification Buffer Interval value in seconds to a maximum value of 1 day. Also, if not configured by the user, the default value of 1 day (as configured by the network provider) is applicable.

4.10.1.1.1.3 Communication Diversion Information Selection Criteria

As a part of the SUBSCRIBE message body, the user may specify further criteria to enable/disable which information about the communication diversion should be notified. By default, all information about a communication diversion would be notified. However, the user may use the following elements for DISABLING a particular kind of information from being notified.

- 1) Information about the Originating party.
- 2) URI of the Diverting party.
- 3) URI of the Diverted-To party.
- 4) Time of the Communication Diversion.
- 5) Reason for the Communication Diversion.
- 6) Identity of the rule which triggered the Communication Diversion.

4.10.1.1.2 Communication Diversion Notification Information

The body of a notification of communication diversion would contain information about the communication diversion, as selected by the various filter criteria configured by the user in the SUBSCRIBE message body. If the SUBSCRIBE did not contain a message body, then all possible information about the communication diversion is notified to the User.

The notifications generated by the server shall be in one of the formats specified in the Accept header field in the SUBSCRIBE request. The XML event package is sent as the body of the NOTIFY method, would contain the following information (subject to the filter criteria) selected by the user.

- 1) **Identity of the Originating party:**
This helps the Diverting user in knowing whose communication was diverted.
- 2) **Information of the Diverting party:**
The Request-URI of the INVITE before the Communication Diversion Service was executed, is informed to the subscribing user.
- 3) **Information about the Diverted-To party:**
The Public User Identity of the Diverted-to User, to whom the communication is being diverted, is informed to the subscribing user.

- 4) Time of the Communication Diversion:
The time of the Communication Diversion is informed to the subscribing user. A time zone shall be indicated.
- 5) Reason for the Communication Diversion:
The Reason for this communication diversion is an integer value and represents the actual reason for the communication diversion. It is the same as the Reason Parameter as provisioned according to clause 4.10.1.1.1.1. The integer value is mapped to the causes defined in annex C. Specifically, the integer value is derived from the cause-param parameter in the History-info header field of the diverted communication at the AS. The UE converts the integer value of the element into a localized diversion reason according to local settings (i.e. preferred language).
- 6) Communication Diversion Rule:
This information identifies the Communication Diversion Rule as mentioned in clause 4.9.1.2 which was executed to result in the communication diversion, which is being notified to the user. It contains the "id" attribute of Communication Diversion Rule defined in [19].
- 7) State change:
Information about the state of the final state machine prior to sending the NOTIFY request. The state can be one of "IDLE", "DIVERSION_NOTIFIED" or "DIVERSION_NOT_NOTIFIED". See draft-avasara-dispatch-comm-div-notification [23].

4.10.2 XML Schema

```

<?xml version="1.0" encoding="UTF-8" ?>
<xs:schema
  targetNamespace="http://uri.etsi.org/ngn/params/xml/comm-div-info"
  xmlns:tns="http://uri.etsi.org/ngn/params/xml/comm-div-info"
  xmlns:xs="http://www.w3.org/2001/XMLSchema"
  xmlns="http://uri.etsi.org/ngn/params/xml/comm-div-info"
  elementFormDefault="qualified"
  attributeFormDefault="unqualified">
  <!--
  This import brings in the XML language definition
  -->
  <xs:import namespace="http://www.w3.org/XML/1998/namespace"
    schemaLocation="http://www.w3.org/2001/03/xml.xsd"/>
  <!--
  Communication Diversion Information. This is the top-level XML element
  -->
  <xs:element name="comm-div-info"
    type="comm-div-info-type" />
  <!--
  Communication Diversion Information Type. This is the top-level XML element
  -->
  <xs:complexType name="comm-div-info-type">
    <xs:sequence>
      <xs:element name="comm-div-sub-info"
        type="comm-div-sub-info-type" minOccurs="0" />
      <xs:element name="comm-div-ntfy-info"
        type="comm-div-ntfy-info-type" minOccurs="0" />
      <xs:any namespace="##other" processContents="lax"
        minOccurs="0" maxOccurs="unbounded"/>
    </xs:sequence>
    <xs:attribute name="entity" type="xs:anyURI"
      use="required"/>
  </xs:complexType>
  <!--
  Communication Diversion Subscription Type.
  Used at Subscription time to
  select Communication Diversions for notification,
  when to notify them and
  what to notify.
  -->
  <xs:complexType name="comm-div-sub-info-type">
    <xs:sequence>
      <xs:element name="comm-div-selection-criteria"
        type="comm-div-selection-criteria-type"
        minOccurs="0" />
      <xs:element name="comm-div-ntfy-trigger-criteria"
        type="comm-div-ntfy-trigger-criteria-type"
        minOccurs="0" />
      <xs:element name="comm-div-info-selection-criteria"

```



```

        type="comm-div-info-selection-criteria-type"
        minOccurs="0" />
      <xs:any namespace="##other" processContents="lax"
        minOccurs="0" maxOccurs="unbounded"/>
    </xs:sequence>
  <xs:anyAttribute namespace="##other" processContents="lax"/>
</xs:complexType>
<!--
Communication Diversion Notification Information Type
Used while notifying the User about the Communication Diversion
-->
<xs:complexType name="comm-div-ntfy-info-type">
  <xs:sequence>
    <xs:element name="originating-user-info"
      type="user-info-type" minOccurs="0" />
    <xs:element name="diverting-user-info"
      type="xs:anyURI" minOccurs="0" />
    <xs:element name="diverted-to-user-info"
      type="xs:anyURI" minOccurs="0" />
    <xs:element name="diversion-time-info"
      type="xs:dateTime" minOccurs="0" />
    <xs:element name="diversion-reason-info"
      type="diversion-reason-info-type" minOccurs="0" />
    <xs:element name="diversion-rule-info"
      type="diversion-rule-info-type" minOccurs="0" />
    <xs:any namespace="##other" processContents="lax"
      minOccurs="0" maxOccurs="unbounded"/>
    <xs:element name="previous-cdivn-state"
      type="cdivn-states-types" minOccurs="0" maxOccurs="1" />
  </xs:sequence>
  <xs:anyAttribute namespace="##other" processContents="lax"/>
</xs:complexType>
<!--
COMMUNICATION DIVERSION SELECTION CRITERIA
-->
<xs:complexType name="comm-div-selection-criteria-type">
  <xs:sequence>
    <xs:element name="originating-user-selection-criteria"
      type="user-selection-criteria-type"
      minOccurs="0" />
    <xs:element name="diverting-user-selection-criteria"
      type="xs:anyURI"
      minOccurs="0" />
    <xs:element name="diverted-to-user-selection-criteria"
      type="xs:anyURI"
      minOccurs="0" />
    <xs:element name="diversion-time-selection-criteria"
      type="time-range-selection-criteria-type"
      minOccurs="0" />
    <xs:element name="diversion-reason-selection-criteria"
      type="diversion-reason-selection-criteria-type"
      minOccurs="0" />
    <xs:any namespace="##other" processContents="lax"
      minOccurs="0" maxOccurs="unbounded"/>
  </xs:sequence>
  <xs:anyAttribute namespace="##other" processContents="lax"/>
</xs:complexType>
<!--
COMMUNICATION DIVERSION NOTIFICATION TRIGGER CRITERIA
-->
<xs:complexType name="comm-div-ntfy-trigger-criteria-type">
  <xs:sequence>
    <xs:element name="notification-time-selection-criteria"
      type="time-range-selection-criteria-type"
      minOccurs="0" />
    <xs:element name="presence-status-selection-criteria"
      type="presence-status-selection-criteria-type"
      minOccurs="0" />
    <xs:element name="notification-buffer-interval" minOccurs="0" default="86400">
      <xs:simpleType>
        <xs:restriction base="xs:integer">
          <xs:maxInclusive value="86400"/>
        </xs:restriction>
      </xs:simpleType>
    </xs:element>
    <xs:any namespace="##other" processContents="lax"
      minOccurs="0" maxOccurs="unbounded"/>
  </xs:sequence>

```

```

    <xs:anyAttribute namespace="##other" processContents="lax"/>
</xs:complexType>
<!--
COMMUNICATION DIVERSION INFORMATION SELECTION CRITERIA
-->
<xs:complexType name="comm-div-info-selection-criteria-type">
  <xs:sequence>
    <xs:element name="disable-originating-user-info"
      type="xs:boolean" default="false" minOccurs="0" />
    <xs:element name="disable-diverting-user-info"
      type="xs:boolean" default="false" minOccurs="0" />
    <xs:element name="disable-diverted-to-user-info"
      type="xs:boolean" default="false" minOccurs="0" />
    <xs:element name="disable-diversion-time-info"
      type="xs:boolean" default="false" minOccurs="0" />
    <xs:element name="disable-diversion-reason-info"
      type="xs:boolean" default="false" minOccurs="0" />
    <xs:element name="disable-diversion-rule-info"
      type="xs:boolean" default="false" minOccurs="0" />
    <xs:any namespace="##other" processContents="lax"
      minOccurs="0" maxOccurs="unbounded"/>
  </xs:sequence>
  <xs:anyAttribute namespace="##other" processContents="lax"/>
</xs:complexType>

<!-- User Info Type -->
<xs:complexType name="user-info-type">
  <xs:sequence>
    <xs:element name="user-name" type="xs:string" minOccurs="0" maxOccurs="1"/>
    <xs:element name="user-URI" type="xs:anyURI"/>
  </xs:sequence>
  <xs:anyAttribute namespace="##other" processContents="lax"/>
</xs:complexType>
<!--
CDIVN FSM STATES
-->
  <xs:simpleType name="cdivn-states-types">
    <xs:list itemType="cdivn-states-type"/>
  </xs:simpleType>
<xs:simpleType name="cdivn-states-type">
  <xs:restriction base="xs:string">
    <xs:enumeration value="IDLE"/>
    <xs:enumeration value="DIVERSION_NOTIFIED"/>
    <xs:enumeration value="DIVERSION_NOT_NOTIFIED"/>
  </xs:restriction>
</xs:simpleType>
<!--
DIVERSION REASON INFO
-->
  <xs:simpleType name="diversion-reason-info-types">
    <xs:list itemType="diversion-reason-info-type"/>
  </xs:simpleType>
<xs:simpleType name="diversion-reason-info-type">
  <xs:restriction base="xs:integer">
    <xs:enumeration value="404"/>
    <xs:enumeration value="486"/>
    <xs:enumeration value="408"/>
    <xs:enumeration value="302"/>
    <xs:enumeration value="487"/>
    <xs:enumeration value="480"/>
    <xs:enumeration value="503"/>
  </xs:restriction>
</xs:simpleType>
<!--
DIVERSION RULE INFO
-->
<xs:complexType name="diversion-rule-info-type">
  <xs:sequence>
    <xs:element name="diversion-rule" type="xs:string"/>
  </xs:sequence>
  <xs:anyAttribute namespace="##other" processContents="lax"/>
</xs:complexType>
<!--
ORIGINATING USER SELECTION CRITERIA
-->
<xs:complexType name="user-selection-criteria-type">
  <xs:sequence>

```

```

    <xs:element name="user-info"
      type="user-info-type" minOccurs="0"
      maxOccurs="unbounded" />
  </xs:sequence>
  <xs:anyAttribute namespace="##other" processContents="lax"/>
</xs:complexType>
<!--
DIVERSION REASON SELECTION CRITERIA
-->
<xs:complexType name="diversion-reason-selection-criteria-type">
  <xs:sequence>
    <xs:element name="diversion-reason-info"
      type="diversion-reason-info-types"/>
  </xs:sequence>
  <xs:anyAttribute namespace="##other" processContents="lax"/>
</xs:complexType>
<!--
TIME RANGE SELECTION CRITERIA
-->
<xs:complexType name="time-range-selection-criteria-type">
  <xs:sequence>
    <xs:element name="time-range"
      type="time-range-type" minOccurs="0"
      maxOccurs="unbounded" />
  </xs:sequence>
  <xs:anyAttribute namespace="##other" processContents="lax"/>
</xs:complexType>
<!--
TIME RANGE INFO
-->
<xs:complexType name="time-range-type">
  <xs:sequence>
    <xs:element name="start-time" type="xs:dateTime" />
    <xs:element name="end-time" type="xs:dateTime" />
  </xs:sequence>
  <xs:anyAttribute namespace="##other" processContents="lax"/>
</xs:complexType>
<!--
PRESENCE STATUS SELECTION CRITERIA
-->
<xs:complexType name="presence-status-selection-criteria-type">
  <xs:sequence>
    <xs:element name="presence-status-info"
      type="presence-status-info-type" minOccurs="0"
      maxOccurs="unbounded" />
  </xs:sequence>
  <xs:anyAttribute namespace="##other" processContents="lax"/>
</xs:complexType>
<!--
PRESENCE STATUS INFO
-->
<xs:complexType name="presence-status-info-type">
  <xs:sequence>
    <xs:element name="presence-status" type="xs:string" />
  </xs:sequence>
  <xs:anyAttribute namespace="##other" processContents="lax"/>
</xs:complexType>
</xs:schema>

```

Annex A (informative): Signalling Flows

A.1 Normal cases

A.1.1 Communication Forwarding unconditional

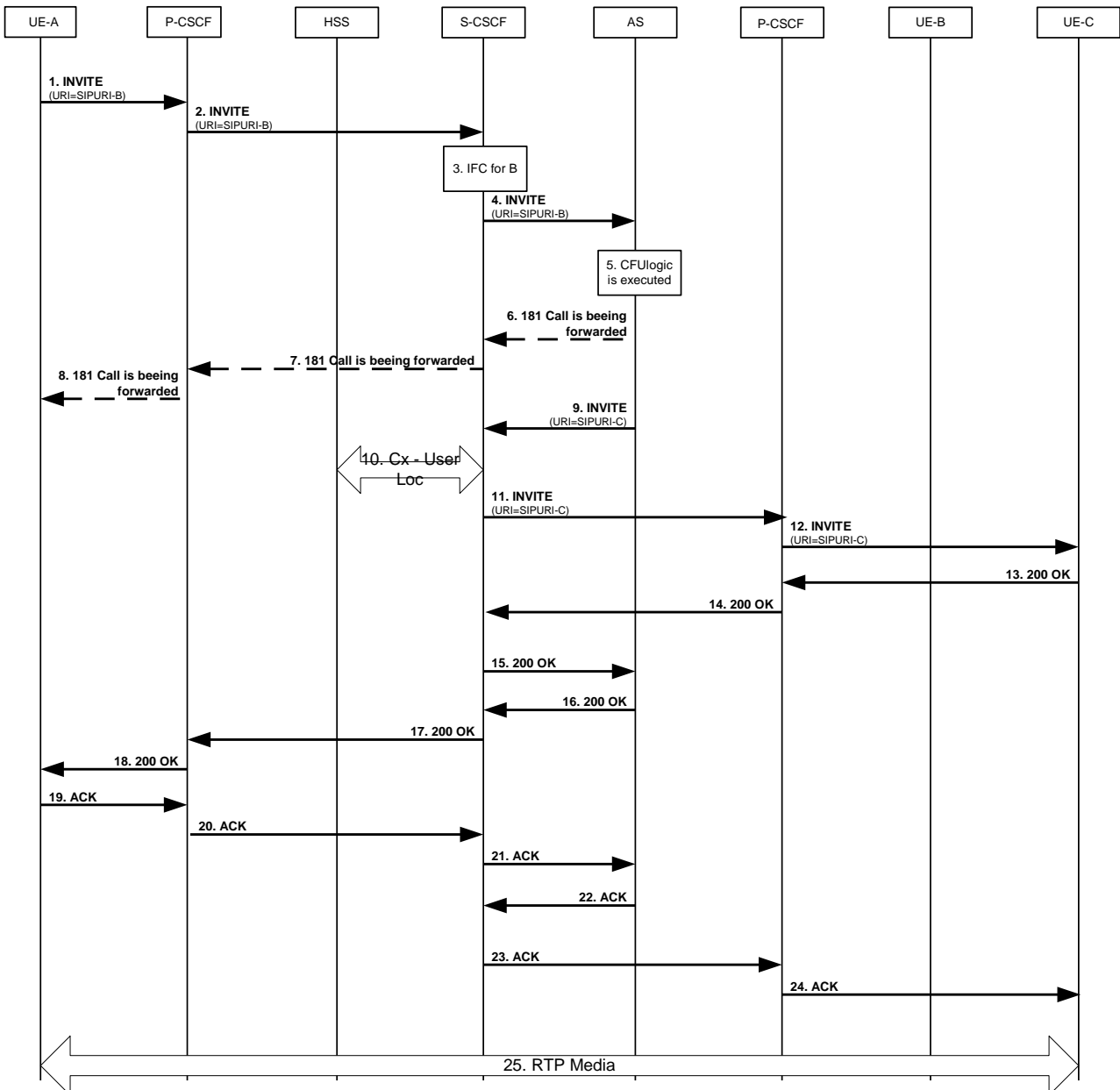

Figure A.1: CFU AS based normal case

User B has activated the CFU service.

User A is sending a communication request towards User B:

- 1 to 2) Initial INVITE request towards User B. The URI-B is subscribed to the CFU service.
- 3 to 4) The based on the IFC the INVITE is forwarded to the AS.
- 5) Procedures for CFU are executed.
- 6 to 8) A 181 may be send towards the User A indicating that the communication is diverted.
- 9) A Invite including URI-C as destination is sent back to the S-CSCF. Additional the History-Info header is included.
History-Info: <sip:User-B@example.com>;index=1,
<sip:User-C@example.com;cause=302>index=1.1.
- 10) S-CSCF looks up to the HSS to identify the location of User-C.
- 11 to 12) The communication is routed towards User-C.
- 13 to 18) The 200 OK is sent Back to the User-A.
- 19 to 24) The ACK is send back to User-B.
- 25) RTP media is established.

A.1.2 Communication Deflection

The flow below describes the Immediate CD feature the only difference compared to a regular CD is that in the regular CD case the "302 (Moved Temporarily) Moved Temporarily" is preceded by a "180 (Ringing) Ringing".

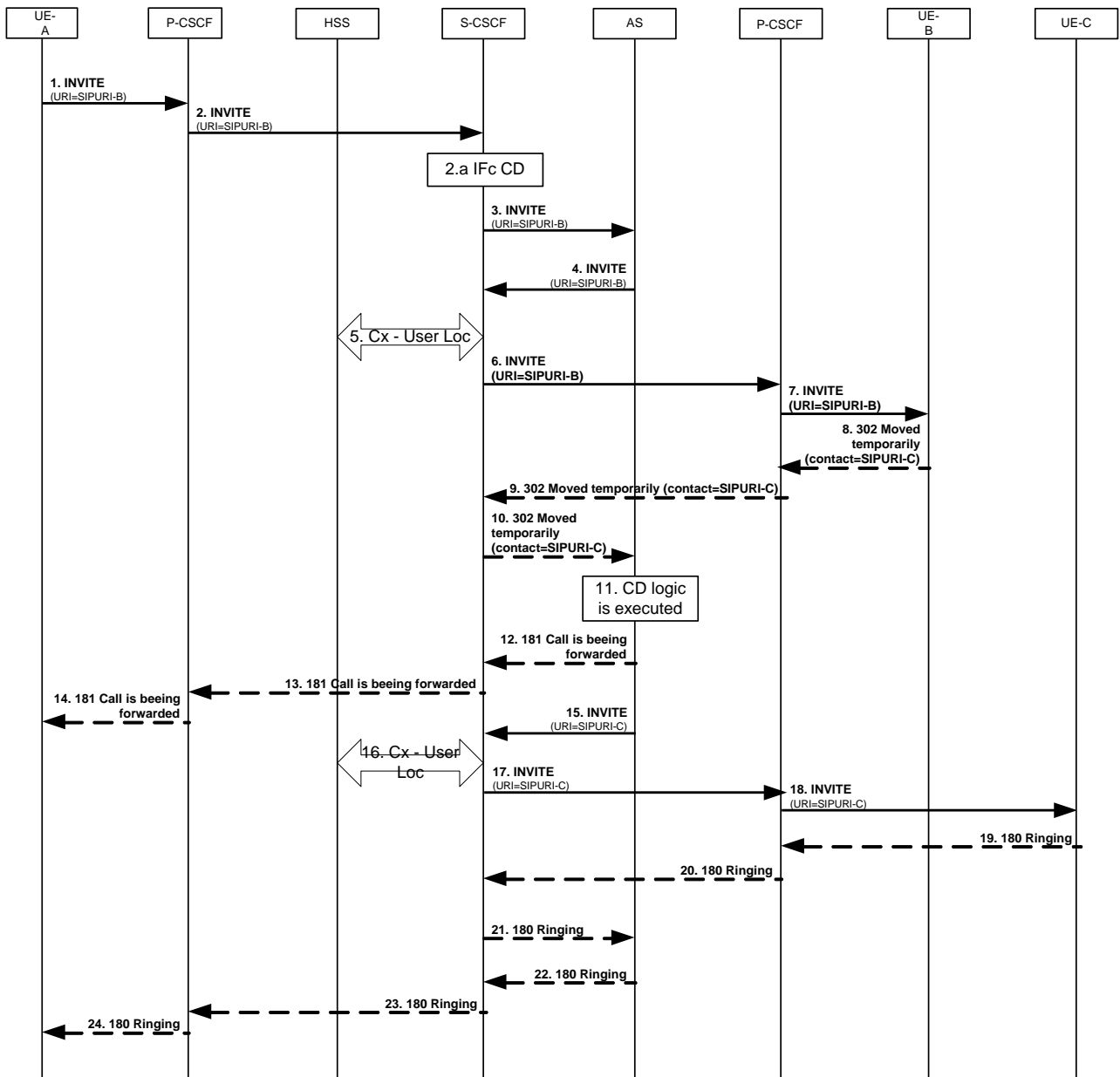

Figure A.2a

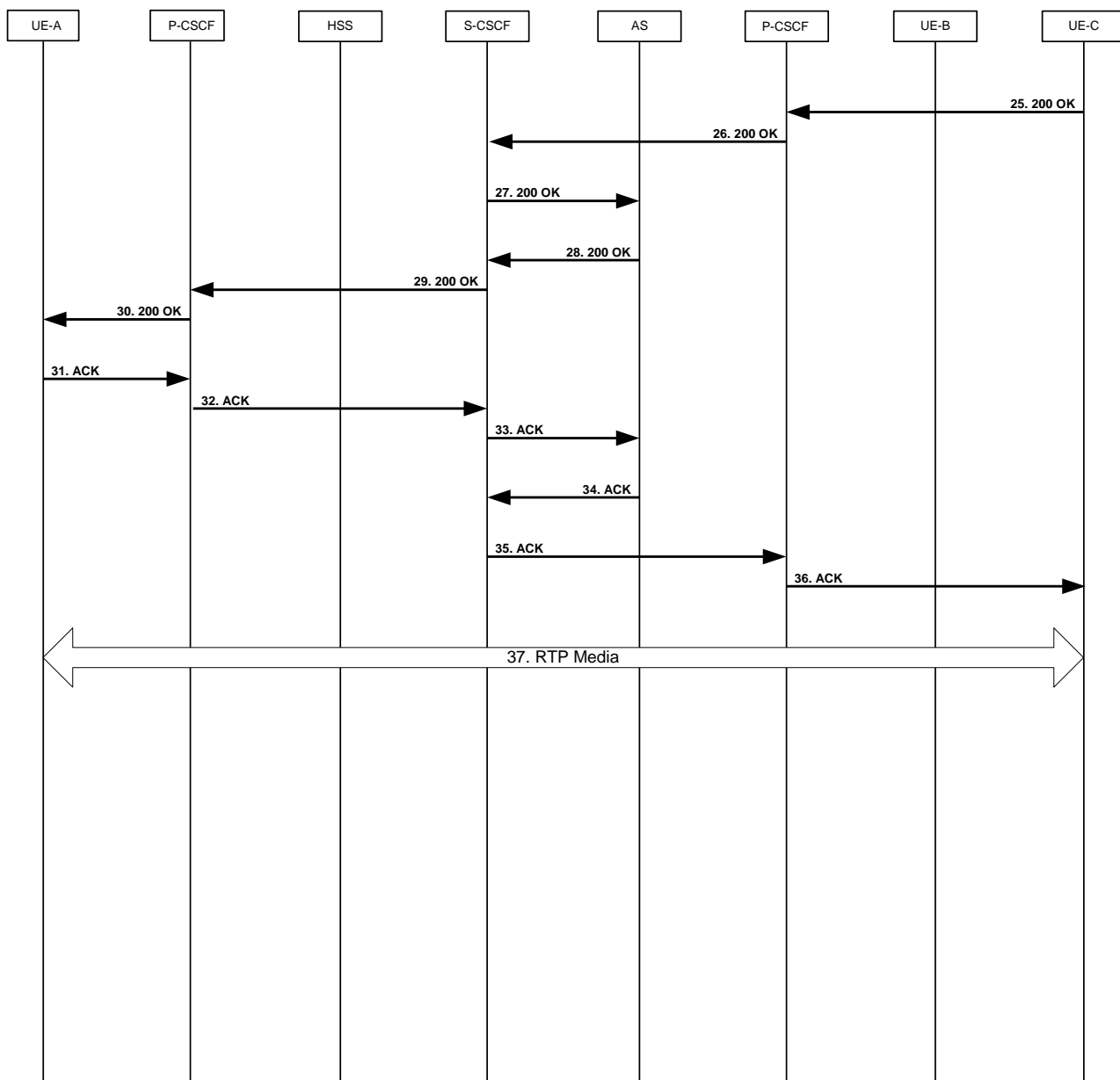

Figure A.2b

User B has activated the CD service.

User A is sending a communication request towards User B:

- 1 to 2) Initial INVITE request towards User B. The URI-B is subscribed to the CFU service.
- 2a to 3) The based on the IFC the INVITE is forwarded to the AS.
- 4 to 7) The INVITE is forwarded to User B due to normal communication procedures.
- 8 to 10) A 302 with a contact header including the URI of the forwarded to user is end back to the AS.
- 11) The CD logic is executed.
- 12 to 14) A 181 may be send towards the User A indicating that the communication is diverted.

- 15 to 18) A Invite including URI-C as destination is sent back to the S-CSCF. Additionally the History-Info header is included.
History-Info: <sip:User-B@example.com?Reason=sip%3Bcause=302>;index=1,
<sip:User-C@example.com;cause=480>index=2.
- 19 to 24) A 180 is sent back to the originating user including a History-Info header as shown above. If no restriction is given the diverted to user will be presented at the UE of user A.
- 25 to 30) The 200 OK is sent Back to the User-A.
- 31 to 36) The ACK is send back to User-B.
- 37) RTP media is established.

A.1.3 Communication Forwarding on non Reply

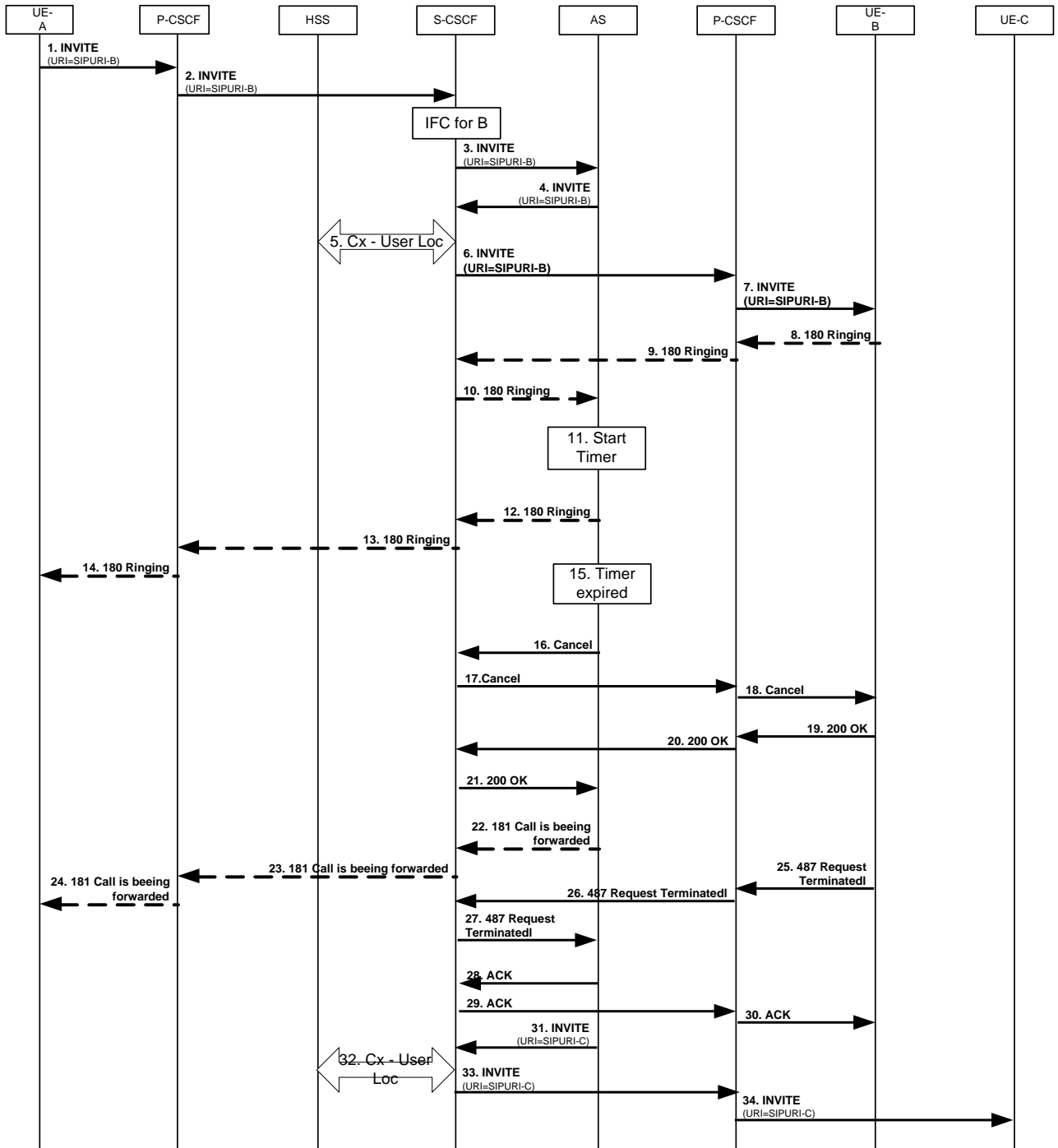

Figure A.3a

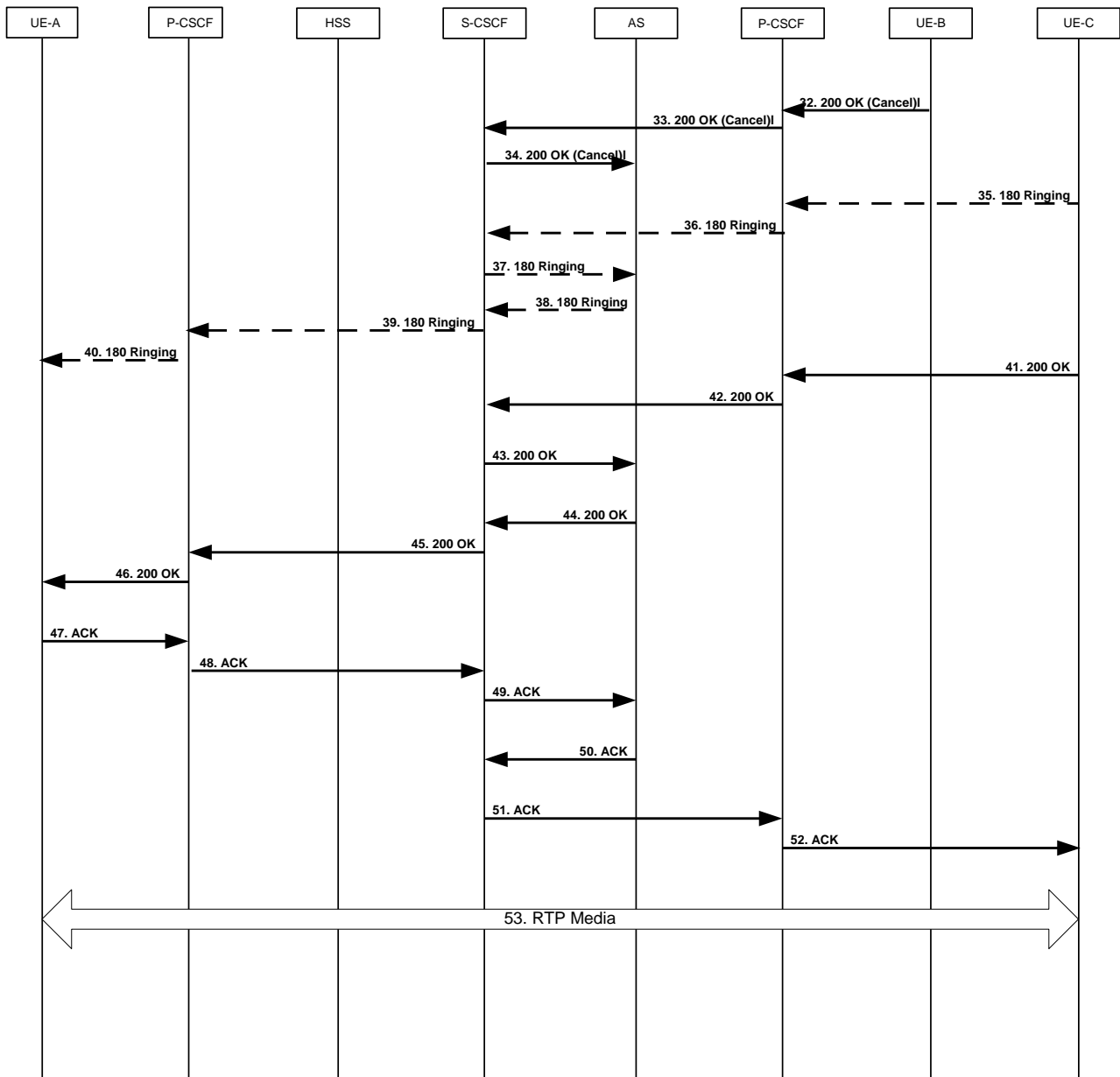

Figure A.3b

User B has activated the CFNR service.

User A is sending a communication request towards User B:

- 1 to 2) Initial INVITE request towards User B. The URI-B is subscribed to the CFU service.
- 3) The based on the IFC the INVITE is forwarded to the AS.
- 4) The INVITE is forwarded to User B due to normal communication procedures.
- 5) The non-reply timer in the AS is started.
- 6 to 7) The INVITE is forwarded to User B due to normal communication procedures.
- 8 to 14) A 180 is sent back to the originating user indicating that the terminating UE is ringing.
- 15) The timer expires.
- 16 to 18) A 181 may be send towards the User A indicating that the communication is diverted.
- 19 to 21) To release the communication to User B the AS sends a CANCEL.

- 22 to 27) A 487 response with a ACK finalize the termination of the dialog between AS and UE:B.
- 28 to 31) A INVITE including URI-C as destination is sent back towards the UE:C. Additional the History-Info header is included.
History-Info: <sip:User-B@example.com>;index=1,
<sip:User-C@example.com;\target=sip:User-B%40example.com;cause=408> index=1.1.
- 32 to 34) The 200 OK for the CANCELED is sent Back to the User-A.
- 35 to 40) A 180 is sent back to the originating user including a History-Info header as shown above. If no restriction is given the diverted to user will be presented at the UE of User A.
- 41 to 46) The 200 OK is sent Back to the User-A.
- 47 to 52) The ACK is send back to User-B.
- 53) RTP media is established.

A.1.4 Communication Forwarding on Busy

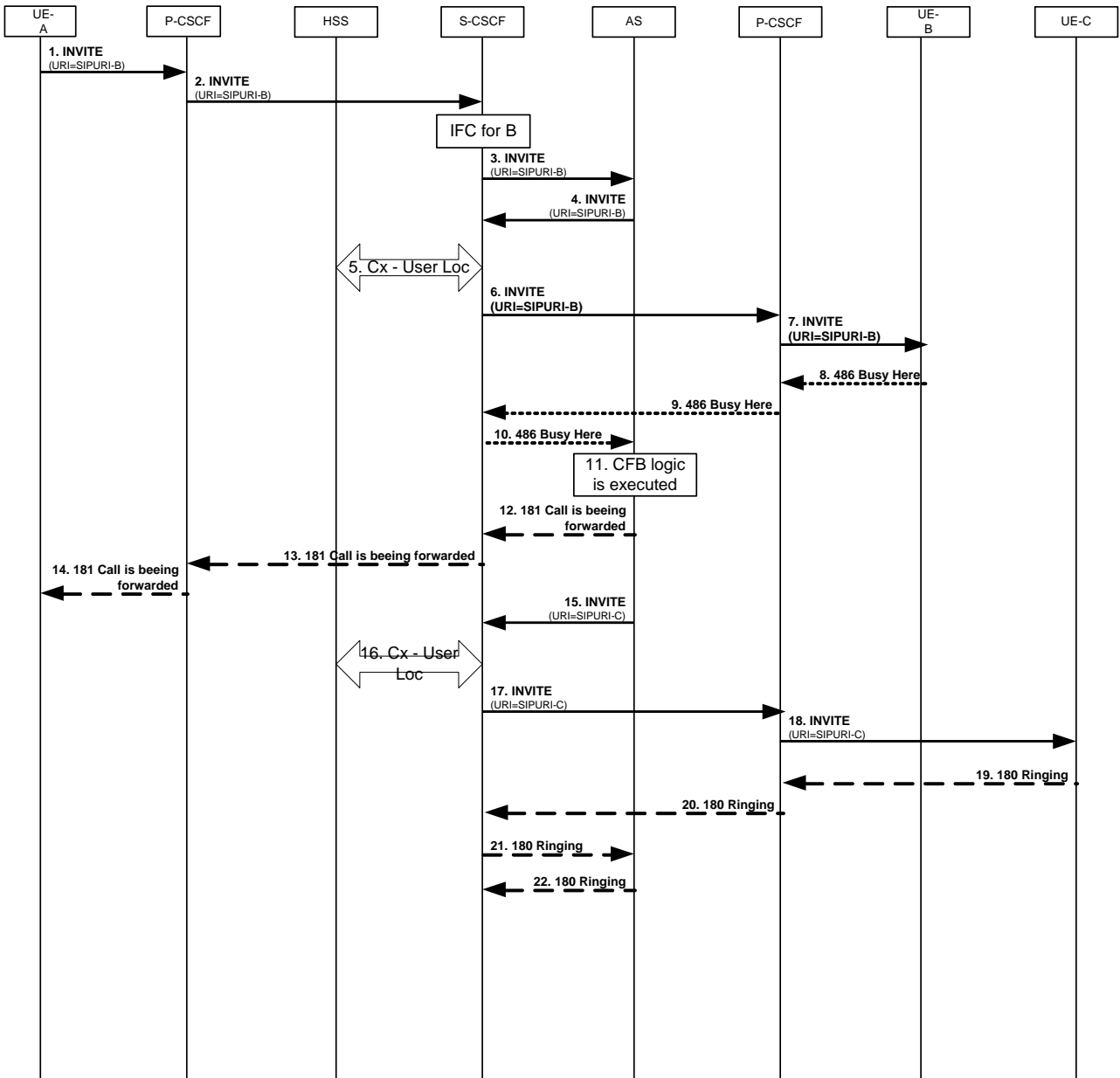

Figure A.4a

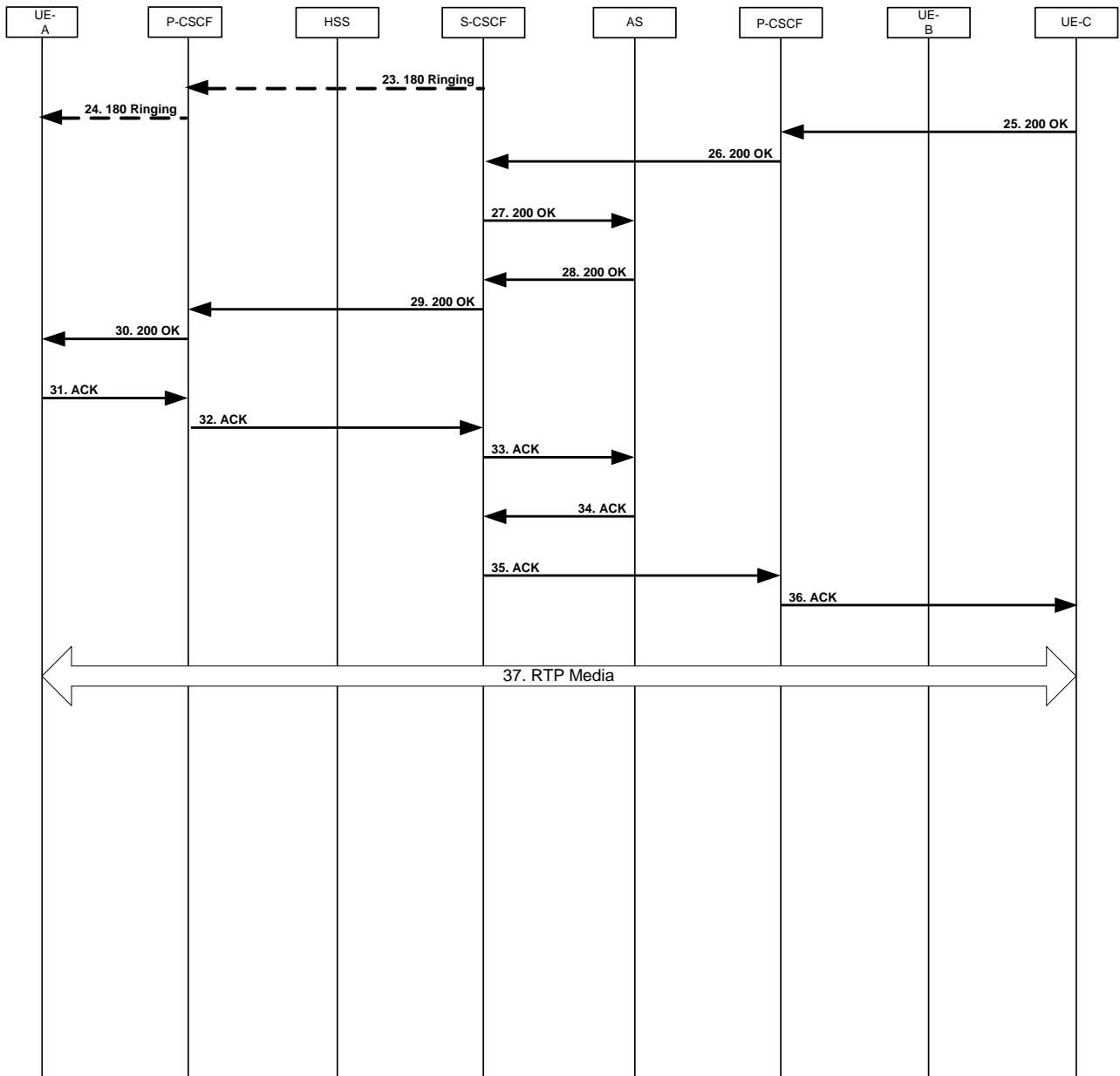

Figure A.4b

A.1.5 Communication Forwarding Not Logged-in (CFNL)

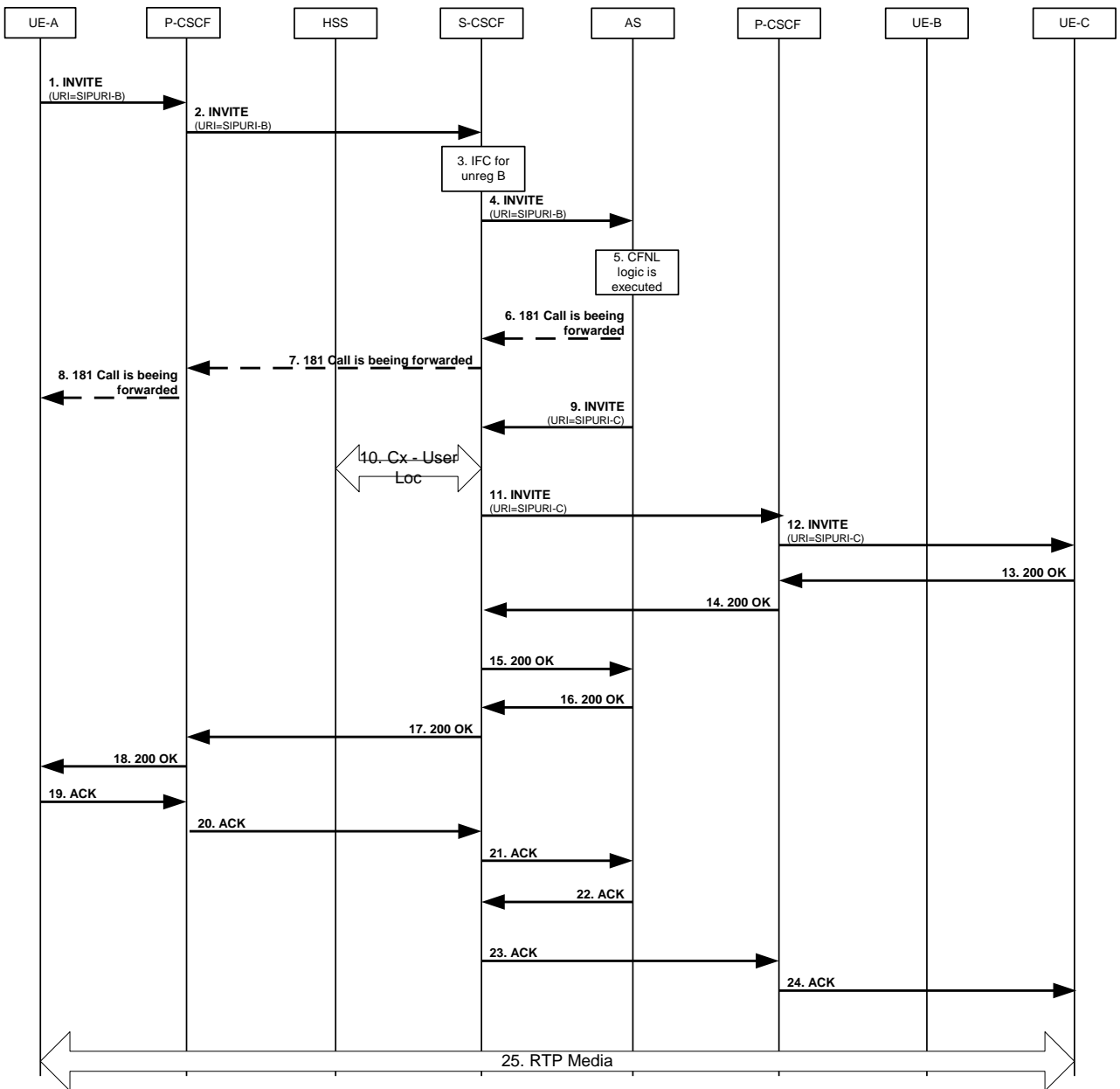

Figure A.5

A.1.6 Communication Diversion Notification (CDIVN)

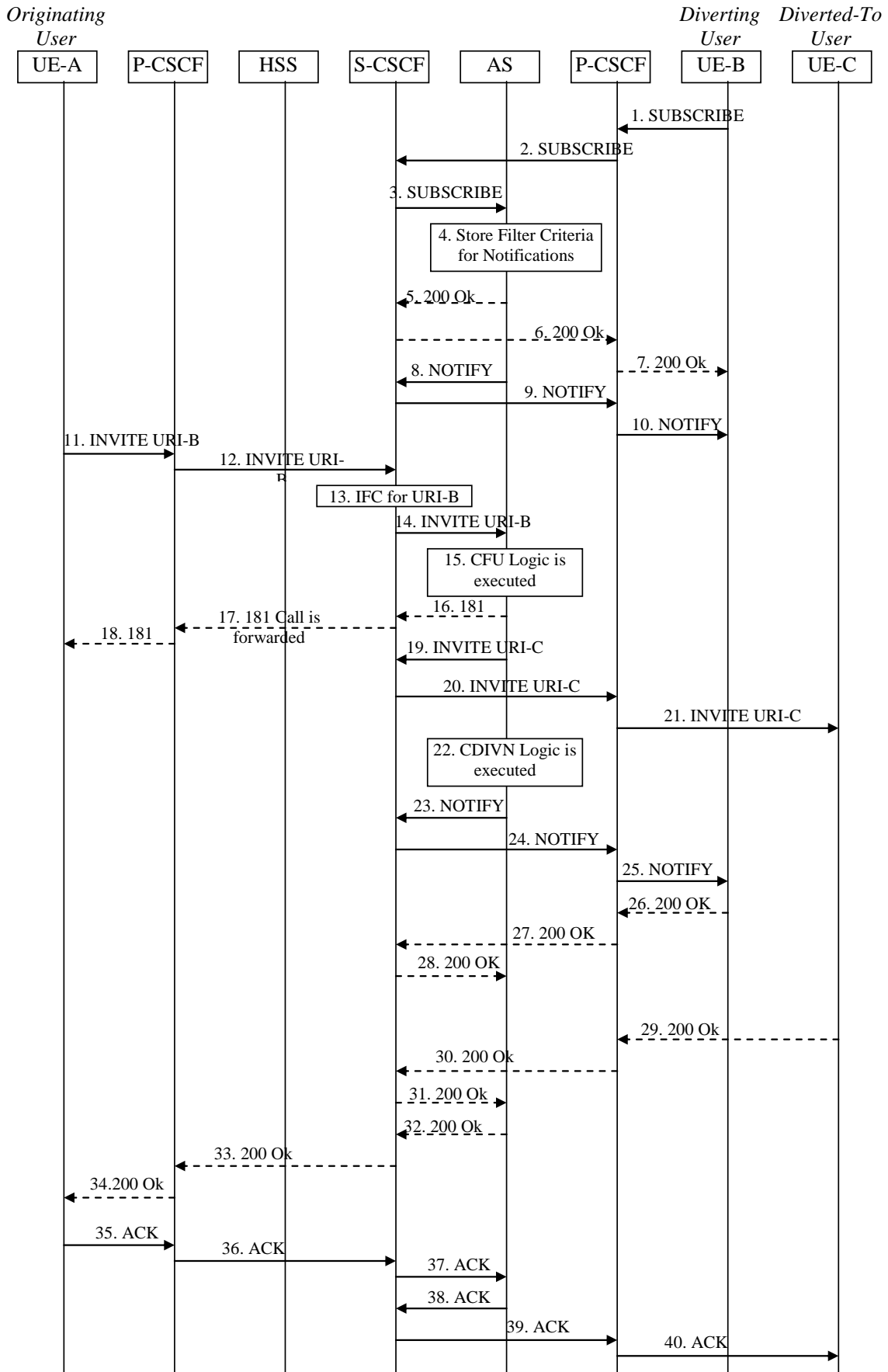

Figure A.6a

- 1 to 10) UE-B subscribing to the CDIVN services.
- 11 to 12) INVITE from caller to the Original Target (the Diverting User) URI-B.
- 13) Based on Initial Filter Criteria (IFC) for User B, the initial INVITE is forwarded to the AS which is serving the CFU Communication Diversion Service.
- 14) INVITE forwarded to the AS.
- 15) Procedures for CFU are executed.
- 16 to 18) A 181 may be send towards the User A indicating that the communication is diverted.
- 19 to 21) An Invite including URI-C as destination is sent back to the S-CSCF.
- 22) Procedures for CDIVN (Communication Diversion Notification) are executed.
- 23) A notification message (NOTIFY) is generated towards the User B (Diverting User), with information about the incoming Communication Diversion from User A being diverted to User C.
- 24 to 25) NOTIFY message with "comm.-div-info" message body is forwarded to UE-B.
- 26 to -28) 200 OK for NOTIFY from UE-B.
- 29 to 34) 200 OK for INVITE from UE-C.
- 35 to 40) ACK from UE-A to UE-C.

A.2 Interworking

A.2.1 Communication Forwarding unconditional

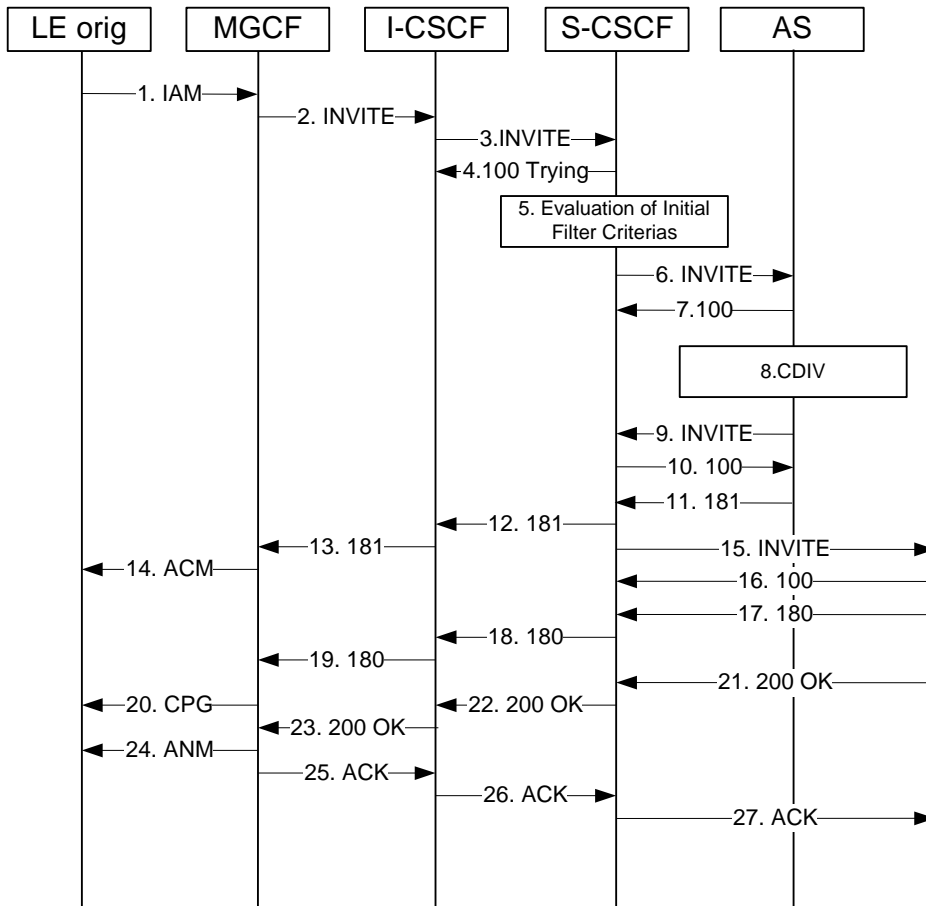

Figure A.6b: Call Forwarding Unconditional

A.2.2 Communication Deflection

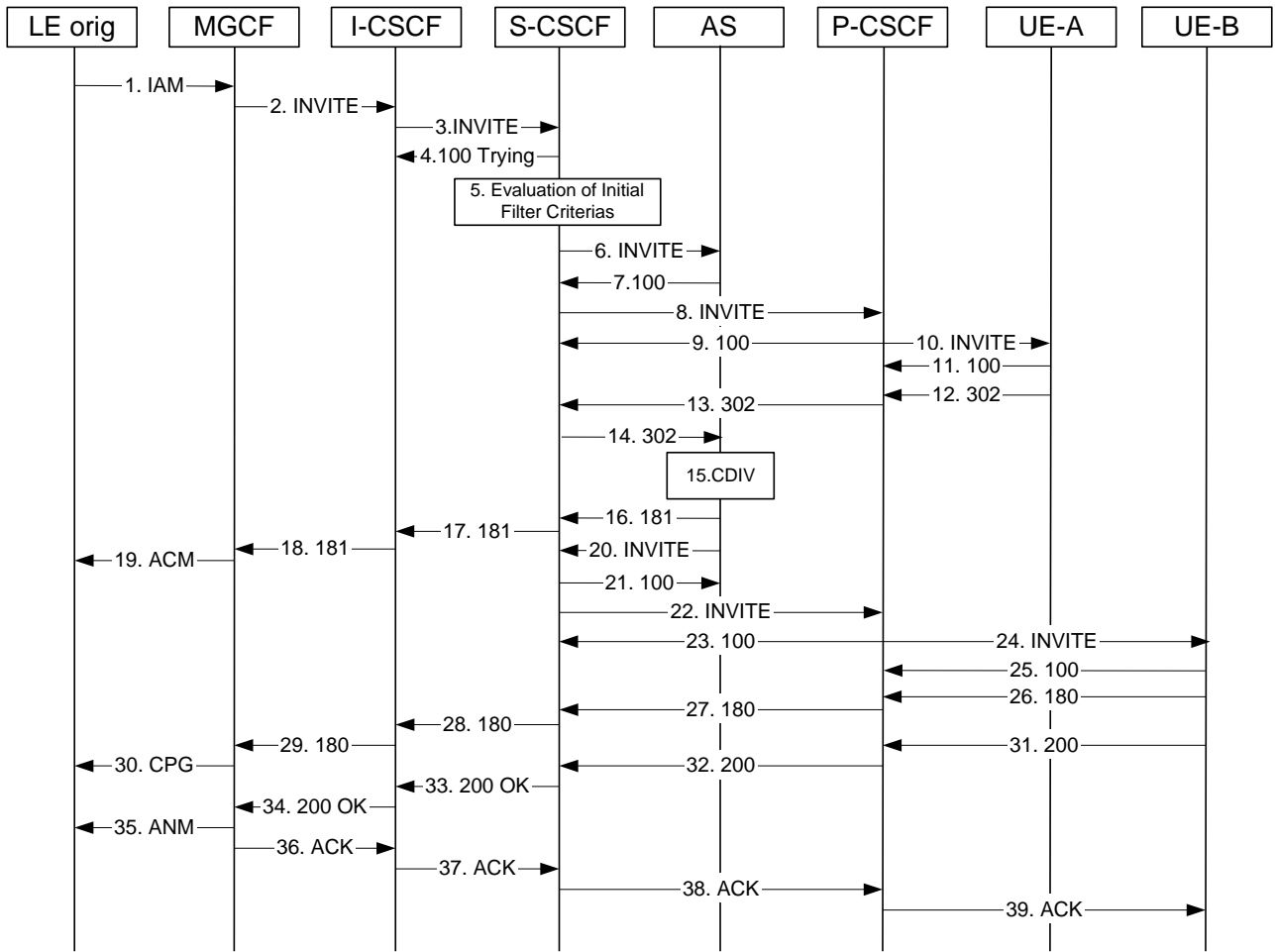

Figure A.7

Annex B (informative): Example of filter criteria

This annex provides an example of a filter criterion that triggers SIP requests that are subject to initial filter criteria evaluation.

An example of an IFC when the CDIV simulation service is active at the diverting S-CSCF is:

- Method: INVITE.

Annex C (informative): Coding considerations

This annex provides an interpretation of the coding of the cause-param URI parameter specified in RFC 4458 [14]

The cause specified in RFC 4458 [14] has the following syntax:

```
cause-param      = "cause" EQUAL Status-Code
```

The Status-Code is originally specified in RFC 3261 [6] as a sequence of 3 digits. It is noted that the Status-Code simply indicates that it is composed of 3 digits, without indicating the list of possible values. In particular, Status-Code is not bound to and must not be confused with the 3 digit numbers defined for SIP responses in RFC 3261 [6]. The Status-Code is used to hold the redirecting reason.

For the purpose of legibility, the cause-param specified in RFC 4458 [14] is interpreted according to the following syntax:

```
cause-param      = "cause" EQUAL Status-Code
Status-Code      = "404" ; Unknown/Not available
                  /  "486" ; User Busy
                  /  "408" ; No Reply
                  /  "302" ; Unconditional
                  /  "487" ; Deflection during alerting
                  /  "480" ; Deflection during immediate response
                  /  "503" ; Mobile subscriber not reachable
```

Annex D (informative): Bibliography

Void.

Annex E (normative): Communication Diversion Notification XML body

E.1 General

This subclause introduces the CDIVN XML body in XML format. The CDIVN XML shall be valid against the CDIVN XML schema defined in annex E.2.

See annex E.4 and annex E.5 for the associated MIME type definition.

E.2 Document Type Definition

The XML Schema is defined subclause 4.10.2.

E.3 XML Schema description

Subclause 4.10.1.1 describes the elements of the CDIVN XML Schema.

E.4 MIME type definition

E.4.1 Introduction

This subclause defines the MIME type for "application/vnd.3gpp.comm-div-info+xml". A CDIVN XML document can be identified with this media type.

E.4.2 Syntax

The following optional parameters are defined:

- "charset": the parameter has identical semantics to the charset parameter of the "application/xml" media type as specified in RFC 3023 [24].

E.4.3 Operation

The encoding considerations for "application/vnd.3gpp.comm-div-info+xml" are identical to those of "application/xml" as described in RFC 3023 [24].

E.5 IANA Registration

NOTE: RFC 4288 [25], subclause 9, states the process that applies in case of changes to the registry of media types. Any future changes to the format or to annex E.5 would invoke this procedure.

Editor's note (CR#0043, WID: MAINT_R2): The MIME type "application/vnd.3gpp.comm-div-info+xml" as defined in this subclause is to be registered in the IANA registry for Application Media Types based upon the following template. The MIME type should be registered after approval at TSG CT #60.

MIME media type name:

application

MIME subtype name:

vnd.3gpp.comm-div-info+xml

Required parameters:

None

Optional parameters:

"charset" the parameter has identical semantics to the charset parameter of the "application/xml" media type as specified in RFC 3023.

Encoding considerations:

binary

Security considerations:

Same as general security considerations for application/xml as specified in subclause 10 of RFC 3023 [132].

In addition, this content type provides a format for exchanging information in SIP, so the security considerations from RFC 3261 apply.

Interoperability considerations:

Same as Interoperability considerations as specified in subclause 3.1 of RFC 3023.

Published specification:

3GPP TS 24.504: "Communication Diversion (CDIV) using IP Multimedia (IM) Core Network (CN) subsystem; Protocol specification", as published in annex E.5, version 8.17.0.

Available via <<http://www.3gpp.org/specs/numbering.htm>>.

Applications which use this media:

Applications that use the 3GPP IM CN subsystem as defined by 3GPP.

Intended usage:

COMMON

Additional information:

1. Magic number(s): none
2. File extension(s): none
3. Macintosh file type code: none
4. Object Identifiers: none

Annex F (informative): Change history

TISPAN #	TISPAN Doc.	CR	Subject/Comment
14ter	14tTD616	001	Correction of XML schema
14ter	14tTD617	002	Correction of misalignment in XML schema
14ter	14tTD532r1	003	Correction of ECT interaction
14ter	14tTD536r1	004	Correction of signalling flow
15bis	15bTD337r6	005	Correction of privacy support, alignment with introduction of GRUU, and introduction of missing subscription option
15bis	15bTD338r3	006	Correction use of timezones, subscription notification option, and value of reason in communication notification
15bis	15TD346r2	007r1	Add interaction between CDIVN and OIR/TIR
15bis	15bTD441r1	008	Correction of the use of the terms Interaction and Interworking in the CDIV Simulation Service description
15bis	15b502r1	010	Correction of XML Schema and XML Schema compliance statement
TISPAN3-WG3	15b151r1	011	Correction and alignment of tables 4.3.1.1 and 4.3.1.2 with ES 302 107
		12	

Change history							
Date	TSG #	TSG Doc.	CR	Rev	Subject/Comment	Old	New
2008-01					Publication as ETSI TS 183 004		2.4.0
2008-01					Conversion to 3GPP TS 24.504		2.4.1
2008-03	CT#39	CP-080096			Based on the decision in CT#39 version 8.0.0 created by MCC	2.4.1	8.0.0
2008-06	CT#40	CP-080350	0002	2	Correction of XDM reference	8.0.0	8.1.0
2008-09	CT#41	CP-080521	0003	1	Correction to the communication diversion service	8.1.0	8.2.0
2008-09	CT#41	CP-080521	0004	1	Correction of notification service activation	8.1.0	8.2.0
2008-09	CT#41	CP-080521	0005	1	Correction of subscription options	8.1.0	8.2.0
2008-09	CT#41	CP-080521	0006	1	Value of "No reply timer" for CDIV	8.1.0	8.2.0
2008-12	CT#42	CP-080852	0007	2	Aligning XML Schema with draft-saklikar-communication-diversion-notification	8.2.0	8.3.0
2008-12	CT#42	CP-080852	0009	2	CR on 24.504 CDIV XML correction	8.2.0	8.3.0
2008-12	CT#42	CP-080851	0010		Correction of the mapping tables for interworking call forwarding	8.2.0	8.3.0
2009-03	CT#43	CP-090211	0011	1	Correct reference	8.3.0	8.4.0
2009-03	CT#43	CP-090253	0014	3	Miscellaneous corrections in History-Info mapping tables	8.3.0	8.4.0
2009-03	CT#43	CP-090124	0015		Map priv-value of "session" and "header" in History-Info	8.3.0	8.4.0
2009-03	CT#43	CP-090124	0016	1	Handle the SIPURI in History-Info	8.3.0	8.4.0
2009-03	CT#43	CP-090251	0017	3	MGCF mapping tables correction	8.3.0	8.4.0
2009-03	CT#43	CP-090124	0018	1	cause-param clarification and corrections	8.3.0	8.4.0
2009-03	CT#43	CP-090124	0019	1	NoReply Timer XML Schema	8.3.0	8.4.0
2009-06	CT#44	CP-090402	0020	3	Setting of the cause parameter when when an AS forwards a communication	8.4.0	8.5.0
2009-06	CT#44	CP-090402	0021		Correction on CDIV mapping	8.4.0	8.5.0
2009-09	CT#45	CP-090662	0022	1	Correcting GRUU matching	8.5.0	8.6.0

2009-09	CT#45	CP-090662	0023		Updating internet draft names and versions	8.5.0	8.6.0
2009-12	CT#46	CP-090905	0025		Determining if served user shall be added to History-Info	8.6.0	8.7.0
2009-12	CT#46	CP-090894	0026		Updating of GRUU references	8.6.0	8.7.0
2009-12	CT#46	CP-090905	0027		CDIV redirection parameters mapping	8.6.0	8.7.0
2010-06	CT#48	CP-100341	0028		NoReplyTimer description is not an action	8.7.0	8.8.0
2010-09	CT#49	CP-100488	0029	1	CDIV corrections	8.8.0	8.9.0
2010-10	CT#50	CP-100730	0030	3	Corrections to CDIV interworking	8.9.0	8.10.0
2011-03	CT#51	CP-110165	0031	1	Reference corrections to CDIV interworking	8.10.0	8.11.0
2011-03	CT#51	CP-110165	0032	1	Correct reference	8.10.0	8.11.0
2011-09	CT#53	CP-110657	0035		<conditions> element values	8.11.0	8.12.0
2011-12	CT#54	CP-110857	0036	1	Correction of Communication Deflection during alerting	8.12.0	8.13.0
2012-03	CT#55	CP-120097	0037	1	CDIV building of Index	8.13.0	8.14.0
2012-06	CT#56	CP-120291	0038	1	History-Info mapping correction for CDIV	8.14.0	8.15.0
2012-06	CT#56	CP-120291	0039	1	Issues with reminder notification of diversion	8.14.0	8.15.0
2013-03	CT#59	CP-130095	0040	1	Correction of CDIV-related interworking	8.15.0	8.16.0
2013-06	CT#60	CP-130224	0041	6	Update reference	8.16.0	8.17.0
2013-06	CT#60	CP-130224	0042	2	Correcting missing MIME type definition	8.16.0	8.17.0
2013-09	CT#61	CP-130484	0044		Update reference	8.17.0	8.18.0