

3GPP TS 24.447 V8.0.0 (2008-03)

Technical Specification

**3rd Generation Partnership Project;
Technical Specification Group Core Network and Terminals;
Telecommunications and Internet converged Services and
Protocols for Advanced Networking (TISPAN);
NGN IMS Supplementary Services;
Advice Of Charge (AOC)
(Release 8)**



The present document has been developed within the 3rd Generation Partnership Project (3GPPTM) and may be further elaborated for the purposes of 3GPP.

The present document has not been subject to any approval process by the 3GPP Organizational Partners and shall not be implemented. This Specification is provided for future development work within 3GPP only. The Organizational Partners accept no liability for any use of this Specification. Specifications and reports for implementation of the 3GPPTM system should be obtained via the 3GPP Organizational Partners' Publications Offices.

Keywords

AOC, ISDN, PSTN, supplementary service

3GPP

Postal address

3GPP support office address

650 Route des Lucioles - Sophia Antipolis
Valbonne - FRANCE
Tel.: +33 4 92 94 42 00 Fax: +33 4 93 65 47 16

Internet

<http://www.3gpp.org>

Copyright Notification

No part may be reproduced except as authorized by written permission.
The copyright and the foregoing restriction extend to reproduction in all media.

© 2008, 3GPP Organizational Partners (ARIB, ATIS, CCSA, ETSI, TTA, TTC).
All rights reserved.

Contents

Foreword	5
1 Scope	6
2 References.....	6
3 Definitions and abbreviations	7
3.1 Definitions	7
3.2 Abbreviations	7
4 Advice Of Charge (AOC).....	8
4.1 Introduction	8
4.2 Description.....	8
4.2.1 General description	8
4.2.2 Charging information at communication set-up time (AOC-S).....	8
4.3 Charging information during the communication (AOC-D)	8
4.4 Charging information at the end of the communication (AOC-E)	8
4.5 Operational requirements	8
4.5.1 Provision/withdrawal.....	8
4.5.2 Requirements on the originating network side.....	8
4.5.3 Requirements on the terminating network side.....	9
4.6 Coding requirements.....	9
4.7 Signalling requirements.....	9
4.7.1 Activation/deactivation/registration.....	9
4.7.2 Invocation and operation.....	9
4.7.2.1 Actions at the served UE	9
4.7.2.2 Actions at the AS of the served user.....	9
4.7.2.2.1 Actions for AOC-S	9
4.7.2.2.1.1 Served user is the originating user.....	9
4.7.2.2.1.2 Served user is the terminating user.....	10
4.7.2.2.2 Actions for AOC-D	10
4.7.2.2.3 Actions for AOC-E.....	10
4.8 Interaction with other services	10
4.8.1 Communication Waiting (CW).....	10
4.8.2 Communication Hold (HOLD)	10
4.8.3 Terminating Identification Presentation (TIP)	10
4.8.4 Terminating Identification Restriction (TIR)	11
4.8.5 Originating Identification Presentation (OIP)	11
4.8.6 Originating Identification Restriction (OIR)	11
4.8.7 CONference calling (CONF)	11
4.8.8 Communication DIVersion services (CDIV)	11
4.8.9 Advice Of Charge (AOC).....	11
4.8.10 Completion of Communications to Busy Subscriber (CCBS) Completion of Communications by No Reply (CCNR)	11
4.8.11 Malicious Communication IDentification (MCID).....	11
4.8.12 Anonymous Communication Rejection and Communication Barring (ACR/CB)	11
4.8.13 Explicit Communication Transfer (ECT).....	11
4.9 Interactions with other networks.....	11
4.10 Parameter values (timers).....	11
Annex A (informative): Signalling flows.....	12
A.1 Introduction.....	12
A.2 User originating AOC service	12
A.2.1 AOC-S	12
A.2.1.1 AOC-S with information in reliable 1xx responses	12
A.2.1.2 AOC-S with AOC information in a 200 OK response	13
A.2.2 AOC-D	14

A.2.3	AOC-E.....	14
A.3	User terminating AOC service	16
A.3.1	AOC-S	16
A.3.2	AOC-D	17
A.3.3	AOC-E.....	18
Annex B (informative):	Example of Filter Criteria.....	20
Annex C (normative):	Charging Information Elements	21
C.1	General.....	21
C.2	AOC-S.....	21
C.2.1	Charged Items	21
C.2.1.1	Charged Item: basic communication	21
C.2.1.2	Charged Item: communication attempt	21
C.2.1.3	Charged Item: communication setup	22
C.2.1.4	Charged Item: operation of services	22
C.2.1.5	Special Charging Arrangement.....	22
C.2.2	Expressing Charging Rates	22
C.2.2.1	Duration charge: Price per time unit, and unit time	22
C.2.2.2	Specific: free of charge	23
C.2.2.3	Specific: flat rate	23
C.2.2.4	Specific: special charging code N.	23
C.2.2.5	Charging unit	23
C.2.2.6	Not available	23
C.3	AOC-D.....	23
C.3.1	Type of charging information.....	23
C.3.2	Recorded charges.....	24
C.3.3	Billing identification for AOC-D.....	24
C.4	AOC-E.....	24
C.4.1	Billing identification for AOC-E.....	24
C.5	Common types/information elements.....	24
C.5.1	Time unit	24
C.5.2	Decimal	25
C.5.3	Scale	25
C.5.4	Currency identifier	25
C.5.5	Currency amount	25
C.5.6	Length of time unit	25
C.5.7	Granularity	25
C.5.8	Type of charging.....	25
C.5.9	Recorded number of currency units	25
Annex D (normative):	AOC XML Schema:.....	27
Annex E (informative):	Change history.....	30

Foreword

This Technical Specification (TS) was been produced by ETSI Technical Committee Telecommunications and Internet converged Services and Protocols for Advanced Networking (TISPAN) and originally published as ETSI TS 183 047 [x]. It was transferred to the 3rd Generation Partnership Project (3GPP) in December 2007.

The contents of the present document are subject to continuing work within the TSG and may change following formal TSG approval. Should the TSG modify the contents of the present document, it will be re-released by the TSG with an identifying change of release date and an increase in version number as follows:

Version x.y.z

where:

- x the first digit:
 - 1 presented to TSG for information;
 - 2 presented to TSG for approval;
 - 3 or greater indicates TSG approved document under change control.
- y the second digit is incremented for all changes of substance, i.e. technical enhancements, corrections, updates, etc.
- z the third digit is incremented when editorial only changes have been incorporated in the document.

1 Scope

The present document specifies the stage three Protocol Description of the Advice Of Charge (AOC) service, based on stage 1 and 2 of the ISDN Supplementary Service Advice Of Charge for all calls (permanent mode). Within the TISPA N NGN Release 2 Next Generation Network (NGN) the stage 3 description is specified using the IP Multimedia Call Control Protocol based on Session Initiation Protocol (SIP) and Session Description Protocol (SDP).

Three AOC services exist:

a) Charging information at communication set-up time (AOC-S)

The AOC-S service enables a user to receive information about the charging rates at communication set-up time and also to receive further information during the communication if there is a change of charging rates.

b) Charging information during the communication (AOC-D)

The AOC-D service enables a user to receive information on the recorded charges for a communication during the active phase of the communication.

c) Charging information at the end of the communication (AOC-E)

The AOC-E service enables a user to receive information on the recorded charges for a communication when the communication is terminated.

2 References

The following documents contain provisions which, through reference in this text, constitute provisions of the present document.

- References are either specific (identified by date of publication, edition number, version number, etc.) or non-specific.
- For a specific reference, subsequent revisions do not apply.
- For a non-specific reference, the latest version applies. In the case of a reference to a 3GPP document (including a GSM document), a non-specific reference implicitly refers to the latest version of that document *in the same Release as the present document*.

Referenced documents which are not found to be publicly available in the expected location might be found at <http://docbox.etsi.org/Reference>.

NOTE: While any hyperlinks included in this clause were valid at the time of publication ETSI cannot guarantee their long term validity.

- [1] ETSI TS 181 002: "Telecommunications and Internet converged Services and Protocols for Advanced Networking (TISPA N); Multimedia Telephony with PSTN/ISDN simulation services".
- [2] ETSI ES 283 003: "Telecommunications and Internet converged Services and Protocols for Advanced Networking (TISPA N); IP Multimedia Call Control Protocol based on Session Initiation Protocol (SIP) and Session Description Protocol (SDP) Stage 3 [3GPP TS 24.229 (Release 7), modified]".
- [3] ISO 4217: "International Organization for Standardization; Type Currency Code List".
- [4] IETF RFC 2976 (2000): "The SIP INFO method".
- [5] IETF RFC 3262 (2002): "Reliability of Provisional Responses in the Session Initiation Protocol (SIP)".
- [6] ETSI TS 183 047 V2.1.1: "Telecommunications and Internet converged Services and Protocols for Advanced Networking (TISPA N); NGN IMS Supplementary Services; Advice Of Charge (AOC)".

3 Definitions and abbreviations

3.1 Definitions

For the purposes of the present document, the terms and definitions given in TS 181 002 [1] apply.

3.2 Abbreviations

For the purposes of the present document, the following abbreviations apply:

AOC	Advice Of Charge
AOC-D	AOC During the call
AOC-E	AOC at the End of the call
AOC-S	AOC at call Set-up time
AS	Application Server
AS-O	Originating Application Server
AS-T	Terminating Application server
CB	Communication Barring
CCBS	Completion of Communication to Busy Subscriber.
CD	Communication Deflection
CDIV	Call DIVersion
CFB	Communication Forwarding Busy
CFNL	Communication Forwarding on No Logged-in
CFNRd	Communication Forwarding Not Registered
CFNRy	Communication Forwarding No Reply
CFU	Communication Forwarding Unconditional
CN	Core Network
CNR	Completion of communication on No Reply
CONF	CONFerence calling
CS	Circuit Switched
CUG	Closed User Group
CW	Communication Waiting
ECT	Explicit Communication Transfer
HOLD	Communication HOLD
IFC	Initial Filter Criteria
IM	IP Multimedia
IMS	IP Multimedia Subsystem
IP	Internet Protocol
ISDN	Integrated Service Data Network
MCID	Malicious Communication IDentification
MIME	Multipurpose Internet Mail Extensions
MMS	Multimedia Messaging Service
MPTY	Multi ParTY service
NGN	Next Generation Network
OIP	Originating Identification Presentation
OIR	Originating Identification Restriction
PLMN	Public Land Mobile Network
PSTN	Public Switch Telephone Network
QoS	Quality of Service
S-CSCF	Serving-Call Session Control Function
SIP	Session Initiation Protocol
TIP	Terminating Identification Presentation
TIR	Terminating Identification Restriction
UE	User Equipment

4 Advice Of Charge (AOC)

4.1 Introduction

Not applicable.

4.2 Description

4.2.1 General description

The Advice Of Charge (AOC) service allows the served user to be informed of IP Multimedia session related charging information.

The AOC service is limited to INVITE-initiated sessions.

The AOC service is not meant to replace the charge metering inside the network which is considered to be correct in all cases.

The charging information given shall relate to the charges incurred on a TISPAN NGN.

4.2.2 Charging information at communication set-up time (AOC-S)

When the AOC-S service is activated, the network shall provide the user with information about the charging rates at communication establishment. In addition, the network shall inform the served user if a change in charging rates takes place during the communication.

4.3 Charging information during the communication (AOC-D)

When the AOC-D service is activated, the network shall provide the user with charging information for a communication during the active phase of this communication. The supplied charging information shall be provided as a cumulative charge incurred so far for the communication (i.e. charges recorded from the start of the communication and until the moment the charging information is sent to the served user), or as charging units.

When the call is released, the network shall send the recorded charges for the communication to the served user.

4.4 Charging information at the end of the communication (AOC-E)

When the AOC-E service is activated, the network shall provide the served user with charging information indicating the recorded charges for a communication when this communication is released.

4.5 Operational requirements

4.5.1 Provision/withdrawal

The AOC services shall be provided to the served user after prior arrangement with the service provider or, as a service provider option, be generally available. Withdrawal of these services shall be made on the served user's request or for service provider reasons.

When available the AOC services shall be provided for all communications (permanent mode).

4.5.2 Requirements on the originating network side

No specific requirements are needed in the network.

4.5.3 Requirements on the terminating network side

No specific requirements are needed in the network.

4.6 Coding requirements

The INFO method according to RFC 2976 [4] is needed in support of AOC-D.

The AOC XML schema is defined in annex D. The AOC XML schema shall be transported as a SIP MIME body. The MIME type for the AOC information is "application/vnd.etsi.aoc+xml". Any SIP message that transports a body with AOC information shall identify the payload as MIME type "application/vnd.etsi.aoc+xml".

4.7 Signalling requirements

4.7.1 Activation/deactivation/registration

Not applicable.

4.7.2 Invocation and operation

Basic communication procedures according to ES 283 003 [2] shall apply, with the following additions.

4.7.2.1 Actions at the served UE

The served UE shall support the INFO method and the AOC XML schema defined in annex D.

If methods or responses are received which contain AOC information, this information may be rendered to the user.

4.7.2.2 Actions at the AS of the served user

When sending AOC information, the AS shall encode this information according to the XML-schema defined in annex D. In addition, for this MIME body the AS shall set the Content-Type header to "vnd.etsi.aoc+xml" and set the Content-Disposition to "render" with the "handling" parameter set to "optional".

In the case the AOC information is transported in a message that is forwarded by the AS that contains already a content body, the AS shall generate a multipart/mixed MIME body containing two sub-parts:

- one with the AOC information; the Content-Type and Content-Disposition of this sub-part should be coded as specified for non-multipart bodies;
- one with the received body; headers describing the content of the received SIP message (e.g. Content-type) should be moved into the headers of the this subpart.

In the case the AOC information is transported in a message that is forwarded by the AS, that contains already a content body and the served user's UE has not indicated support for multipart content, the AS shall forward the message unchanged.

NOTE: The above clause ensures that a communication setup is not affected in case a terminal does not support multipart content.

4.7.2.2.1 Actions for AOC-S

4.7.2.2.1.1 Served user is the originating user

When an INVITE request is received, and the served user is subscribed to AOC-S service, the AS shall either (network operator option) operate as a SIP proxy as specified in clause 5.7.4 of ES 283 003 [2] and in RFC 3262 [5] and include the AOC information in the content body of a reliable 1xx provisional responses, or operate as a routing B2BUA as specified in clause 5.7.5 of ES 283 003 [2] and include the AOC information in the content body a 200 OK response forwarded by the AS.

If the charging rates change during the communication, the AS shall send the AOC information to the UE of the served user in the content body of a mid-dialog request forwarded by the AS or an INFO request generated by the AS.

If no charging information is available, then the AS may, as a network option, stop the communication establishment before the session is confirmed.

4.7.2.2.1.2 Served user is the terminating user

The AS shall operate as a routing B2BUA as specified in clause 5.7.5 of ES 283 003 [2].

When an INVITE request is received, and the served user is subscribed to the AOC-S service, the AS shall include the AOC information in the content body in the INVITE before sending the INVITE to the terminating UE.

If the charging rates change during the communication, the AS shall send the AOC information to the UE of the served user in the content body of a mid-dialog request forwarded by the AS or an INFO request generated by the AS.

If no charging information is available, then the AS may, as a network option, not forward the communication invitation.

4.7.2.2.2 Actions for AOC-D

The AS shall operate as a routing B2BUA as specified in clause 5.7.5 of ES 283 003 [2].

The procedures for AOC-D service at the AS are the same for the originating and the terminating user.

If the user is subscribed to AOC-D service, the AS may provide charging information to the user at any moment during the active phase of the communication. When sending the charging information, the AS shall include the AOC information in the content body of a mid-dialog request or mid-dialog response forwarded by the AS to the served user or an INFO request to the served user generated by the AS. The supplied charging information shall be provided as a cumulative charge incurred so far for the communication (i.e. charges recorded from the start of the communication until the moment the charging information is sent to the served user).

When the communication is terminated, the AS shall include the recorded AOC information for the communication in the content body of either the BYE request or the final response to the BYE request sent to the served user. If the communication is free of charge, then the AS shall indicate the charged amount as zero in the AOC information.

4.7.2.2.3 Actions for AOC-E

The AS shall operate as a SIP proxy as specified in clause 5.7.4 of ES 283 003 [2].

The procedures for AOC-E service at the AS are the same for the originating and the terminating user.

If the user is subscribed to AOC-E service, when the communication is terminated the AS shall include the recorded AOC information for the communication in the content body of either the BYE request or the final response to the BYE request sent to the served user. If the communication is free of charge, then the AS shall indicate the charged amount as zero in the AOC information.

4.8 Interaction with other services

4.8.1 Communication Waiting (CW)

No impact, i.e. neither service shall affect the operation of the other NGN service.

4.8.2 Communication Hold (HOLD)

No impact, i.e. neither service shall affect the operation of the other NGN service.

4.8.3 Terminating Identification Presentation (TIP)

No impact, i.e. neither service shall affect the operation of the other NGN service.

4.8.4 Terminating Identification Restriction (TIR)

No impact, i.e. neither service shall affect the operation of the other NGN service.

4.8.5 Originating Identification Presentation (OIP)

No impact, i.e. neither service shall affect the operation of the other NGN service.

4.8.6 Originating Identification Restriction (OIR)

No impact, i.e. neither service shall affect the operation of the other NGN service.

4.8.7 CONFerence calling (CONF)

No impact, i.e. neither service shall affect the operation of the other NGN service.

NOTE: AOC information as result of a CONF invocation is out of scope the present document.

4.8.8 Communication DIVersion services (CDIV)

No impact, i.e. neither service shall affect the operation of the other NGN service.

4.8.9 Advice Of Charge (AOC)

If the AOC-D and AOC-E services are activated for the same communication, at the end of the communication the network shall only send AOC-E type information.

4.8.10 Completion of Communications to Busy Subscriber (CCBS) Completion of Communications by No Reply (CCNR)

No impact, i.e. neither service shall affect the operation of the other NGN service.

4.8.11 Malicious Communication IDentification (MCID)

No impact, i.e. neither service shall affect the operation of the other NGN service.

4.8.12 Anonymous Communication Rejection and Communication Barring (ACR/CB)

No impact, i.e. neither service shall affect the operation of the other NGN service.

4.8.13 Explicit Communication Transfer (ECT)

No impact, i.e. neither service shall affect the operation of the other NGN service.

NOTE: AOC information as result of a ECT invocation is out of scope of the present document.

4.9 Interactions with other networks

Not applicable.

4.10 Parameter values (timers)

Not applicable.

Annex A (informative): Signalling flows

A.1 Introduction

The service is divided into two aspects:

- a) Application Server gathers information: this is out of scope of the present document.
- b) User is provided the AOC Information.

A.2 User originating AOC service

A.2.1 AOC-S

A.2.1.1 AOC-S with information in reliable 1xx responses

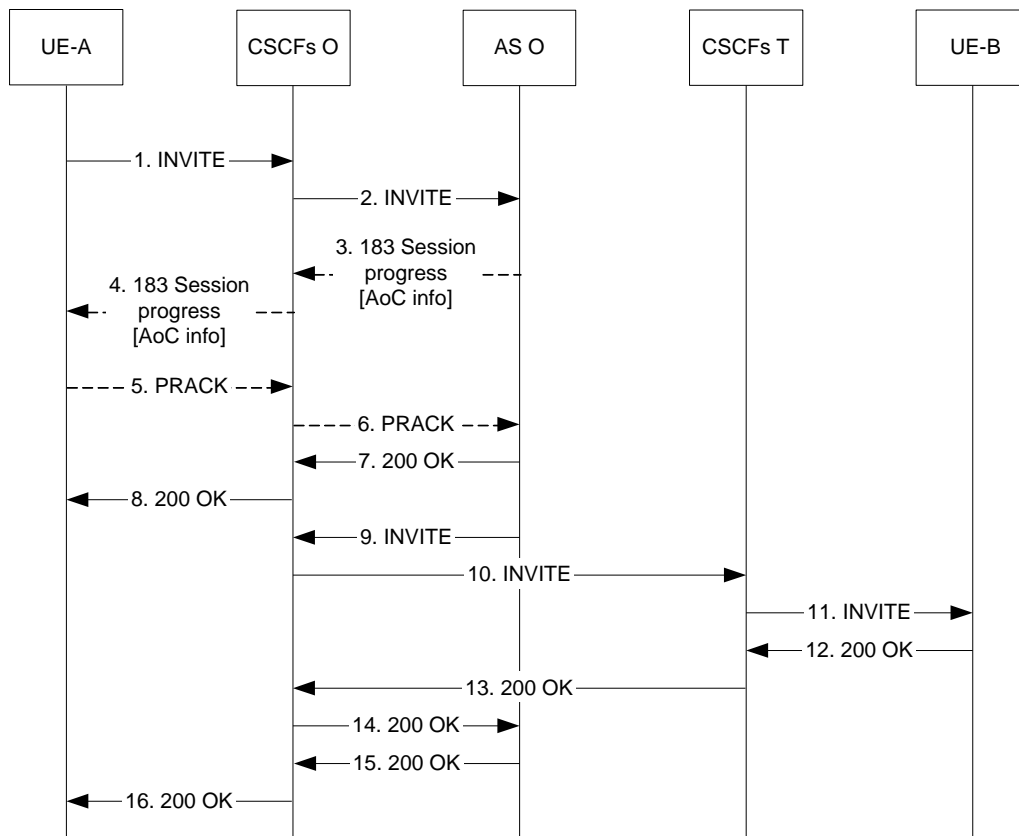

Figure A.2.1.1: Charging info during session set-up (originating side)

Figure A.2.1.1 shows one ordering of the messages. Message 3 and message 9 can be sent at the same moment.

General

The AOC information shall be provided for every communication. This is provisioned in the AS. The AOC information is sent to UE-A in a 183 Session Progress response.

Call flows

- 1 to 5 and 1 to 2 The communication is initiated by UE-A by sending an INVITE. The Request URI will include the URI of UE-B. After IFC evaluation in the S-CSCF the INVITE is routed to the Originating AS. The INVITE will indicate support for 100rel extension.
- 3 to 8 The Originating AS sends the AOC information to UE-A in a reliable 183 response.
- 9 to 11 The INVITE request is sent to UE-B.
- 12 to 16 The UE-B answers the communication. The 200 OK response is generated by UE-B.

A.2.1.2 AOC-S with AOC information in a 200 OK response

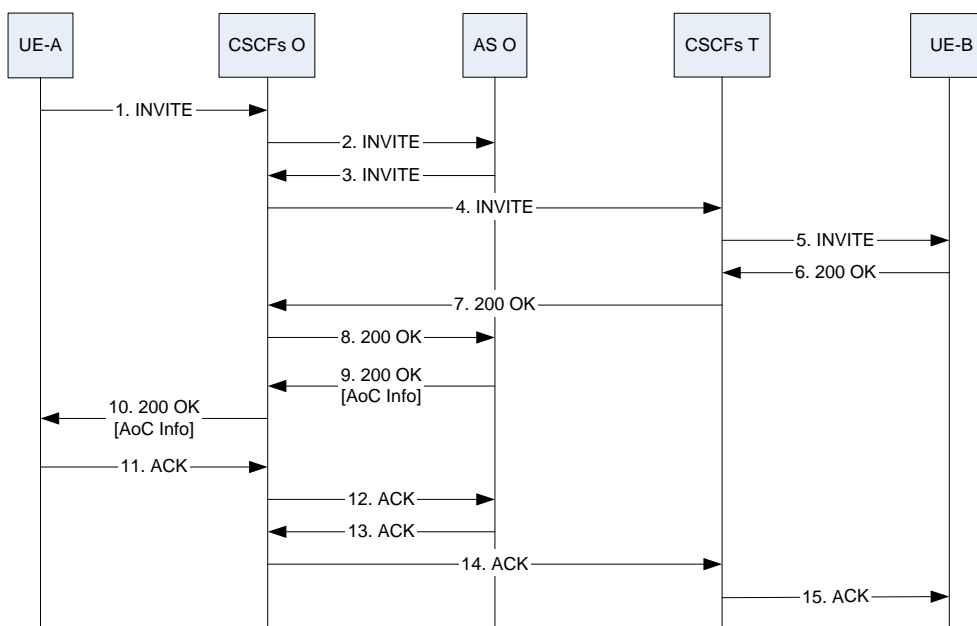

Figure A.2.1.2: Charging info in 200 OK during session set-up (originating side)

Figure A.2.1.2 shows one ordering of the messages.

General

The AOC information shall be provided for every call. This is provisioned in the AS. The AOC information is sent to UE-A in 200 OK (INVITE) after receiving a 200 OK (INVITE) response from UE-B.

Call flows

- 1-5 The call is initiated by UE-A by sending an INVITE. The Request URI will include the URI of UE-B. The INVITE is routed via the Originating AS to UE-B.
- 6-10 UE-B answers the call. The 200 OK response is generated by UE-B. The Originating AS sends the AOC information to UE-A in this 200 OK response.
- 11-15 UE-A sends ACK to UE-B and the session is established.

A.2.2 AOC-D

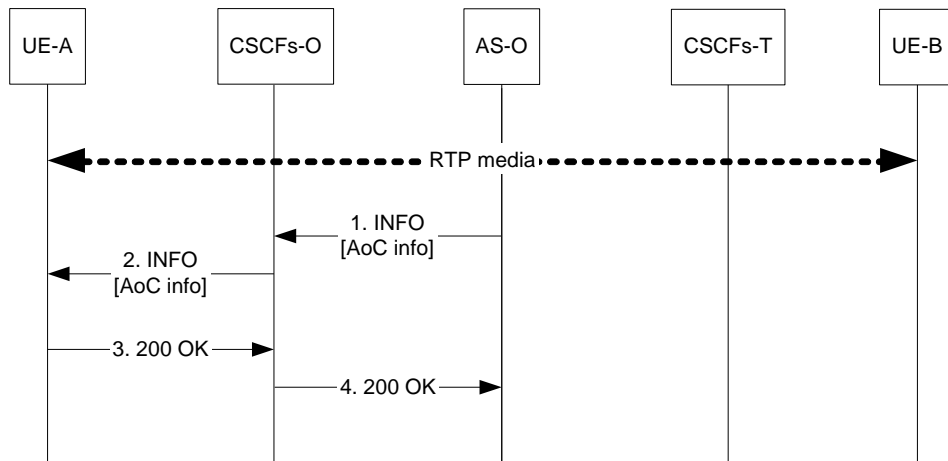

Figure A.2.2.1: Charging info during the communication

This may be a continuation of figures A.2.1.1 or A.2.1.2.

Call flow

- 1-4 When the charging rate is changes, an INFO request is send from the Originating AS to UE-A. The AOC information is included in the INFO request.

A.2.3 AOC-E

Calling party clears

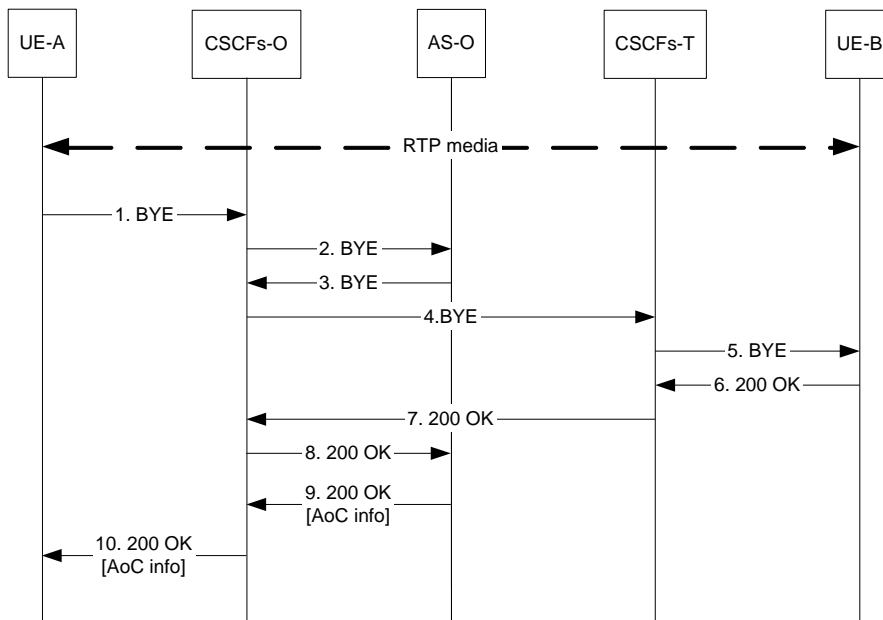

Figure A.2.3.1: Calling party clears

The AOC information shall be provided for every communication after the communication has finished. This is provisioned in the AS. The AOC information is sent to the terminal in a 200 OK (BYE), which is originated from UE-B.

Call Flow

The communication has been set up as a normal communication.

- 1-5 UE-A generates a BYE to terminate the session, which is routed to UE-B.
- 6-10 UE-B sends a 200 OK (BYE) towards UE-A. When the Originating AS receives the 200 OK response, it adds the AOC information to the 200 OK (BYE) response.

Called party clears

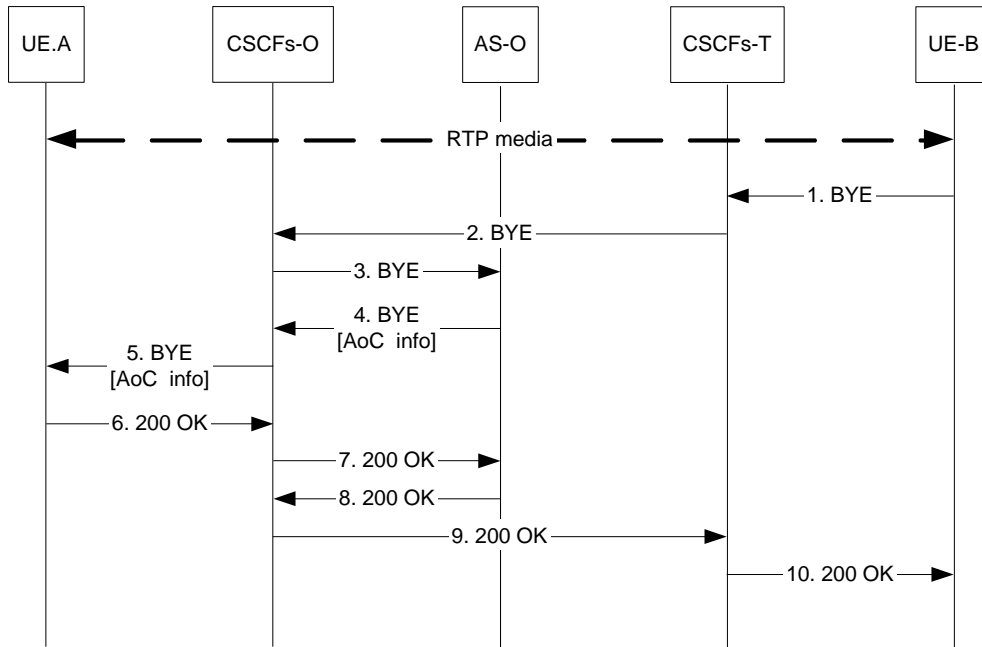

Figure A.2.3.2: Called party clears

The AOC information shall be provided for every communication after the communication has finished. This is provisioned in the AS. The charging info is sent to the terminal in a BYE request, which is originated from UE-B.

Call Flow

The communication has been set-up as a normal communication.

- 1-5 UE-B generates a BYE to terminate the session, which is routed to the UE-A. When the Originating AS receives the BYE request, it adds the AOC information to the BYE Request..
- 6-10 UE-A sends a 200 OK (BYE) towards UE-B.

A.3 User terminating AOC service

A.3.1 AOC-S

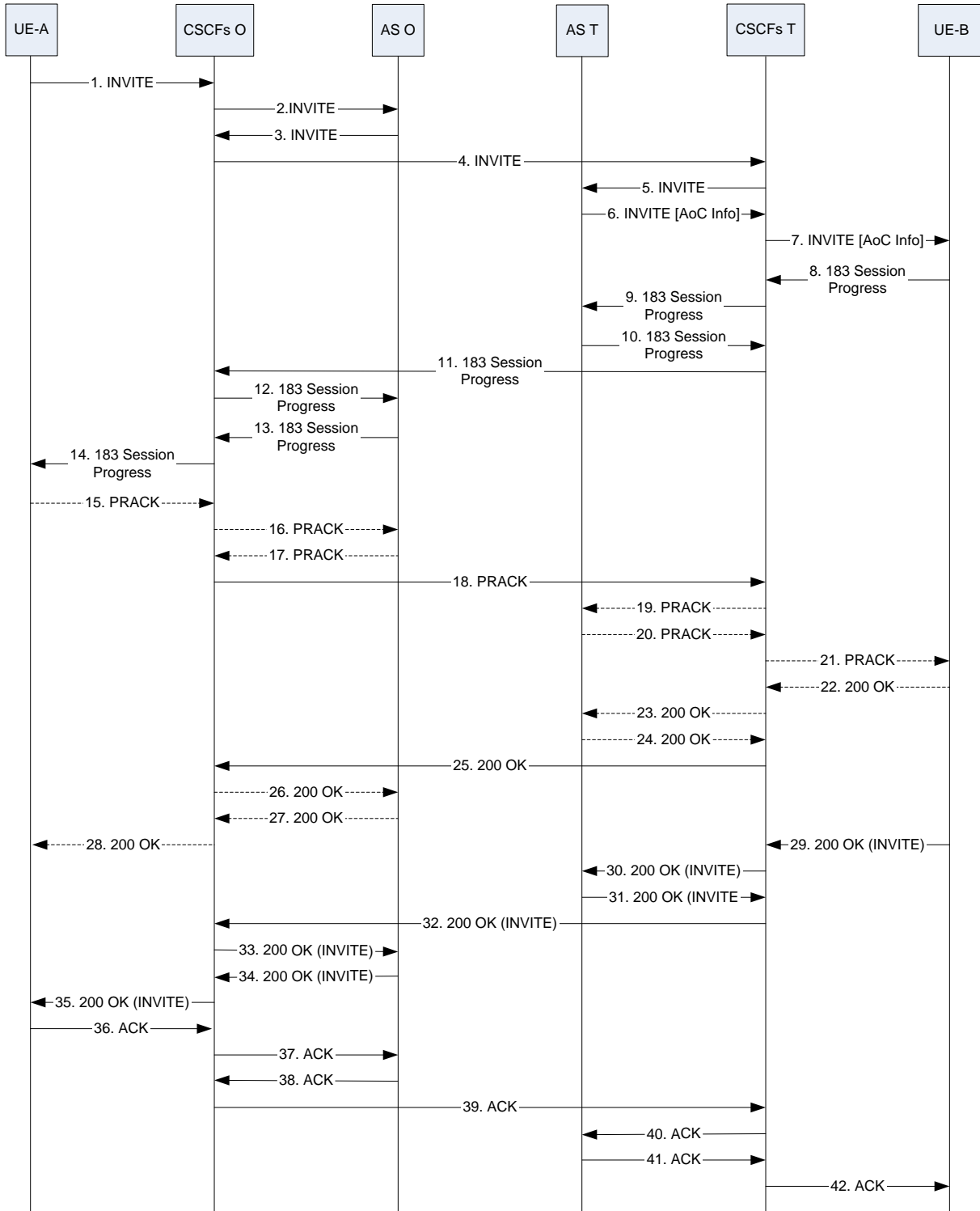

Figure A.3.1.1: Charging info during session set-up on the terminating side

General

The AOC information shall be provided for every call. This is provisioned in the AS. The AOC information is sent to the terminal in an INVITE request. Since this is a service that is charged an acknowledgement is required to ensure that the charging info is transferred.

Call flows

- 1-5 The call is initiated by UE-A by sending an INVITE. The Request URI will include the URI of UE-B. The INVITE is routed to the Originating AS and the Terminating AS. The INVITE will indicate that 100rel extension is supported.
- 6-7 the Terminating AS will include the charging info in the INVITE sent to the UE-B.
- 8-28 UE-B sends a reliable provisional response to indicate that INVITE is being processed.
- 29-35 UE-B answers with a 200 OK (INVITE) response and sends it to UE-A.
- 36-42 UE-A sends a ACK to acknowledge the 200 OK (INVITE) and the session is established successfully.

A.3.2 AOC-D

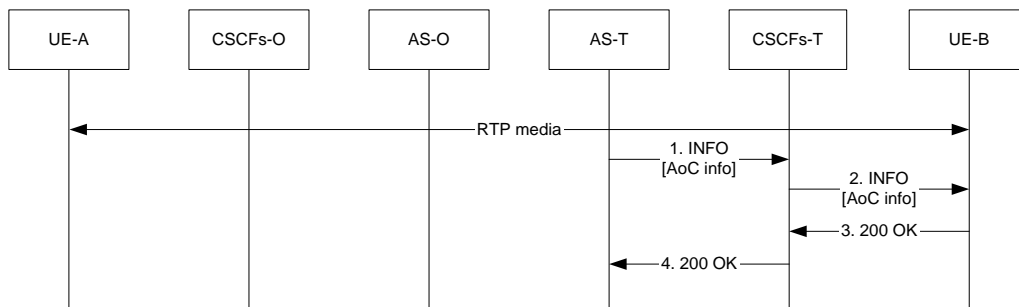

Figure A.3.2.1: Charging info during the call (terminating)

This may be a continuation of figures A.3.1.1 or A.3.1.2.1.

Call flows

- 1-4 When the charging rate is changes, an INFO request is send from the terminating AS to UE-B. The AOC information is included in the INFO request.

A.3.3 AOC-E

Calling party clears

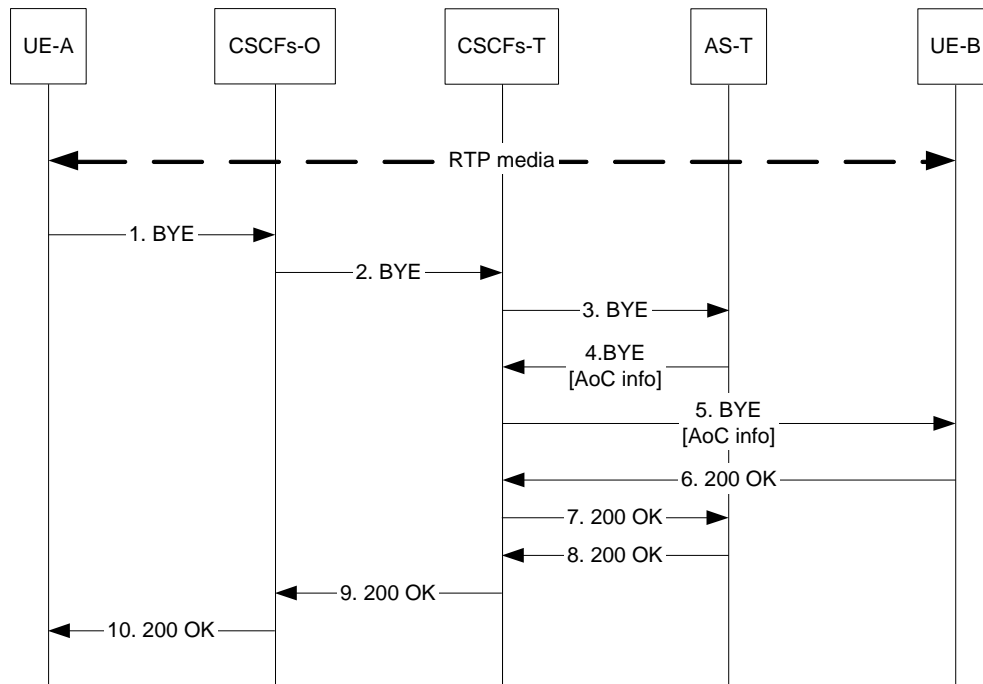

Figure A.3.3.1: Calling party clears

The AOC information shall be provided for every communication after the communication has finished. This is provisioned in the AS. The AOC information is sent to the terminating user in the BYE request which is originated from UE-A.

Call Flow

The communication has been set up as a normal communication.

- 1-5 UE-A generates a BYE to terminate the session, which is routed to the UE-B. When the Terminating AS receives the BYE request, it adds the AOC information.
- 6-10 UE-B sends a 200 OK towards UE-A.

Called party clears

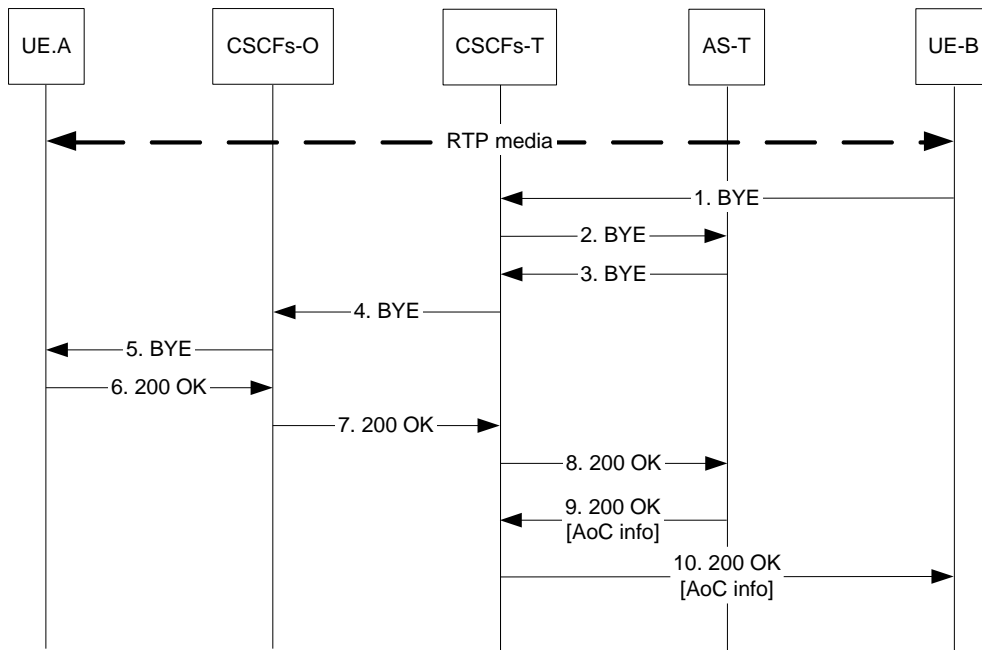

Figure A.3.3.2: Called party clears

The AOC information shall be provided for every communication after the communication has finished. This is provisioned in the AS. The charging info is sent to the terminating user in the 200 OK response, which is originated from UE-a.

Call Flow

The communication has been set-up as a normal communication.

- 1-5 UE-B generates a BYE to terminate the session, which is routed to UE-A.
- 6-10 UE-A sends a 200 OK response towards UE-B. When the Terminating AS receives the 200 OK, it adds the AOC information.

Annex B (informative): Example of Filter Criteria

This annex provides an example of a filter criterion that triggers SIP requests that are subject to initial filter criteria evaluation.

An example of an IFC when the AOC service is active at the originating S-CSCF is:

- Method: INVITE.

Annex C (normative): Charging Information Elements

C.1 General

This annex describes the charging information to be provided to the served user.

C.2 AOC-S

The AOC-S service provides tariff information at the start of the call or when tariff changes occur during the call.

C.2.1 Charged Items

AOC-S can provide a *list of charged items* or a *special charging arrangement*.

Following charged items are thought applicable:

- basic communication;
- communication attempt;
- communication setup;
- operation of supplementary services.

The special charging arrangement excludes all other charged items and is therefore mentioned separately.

C.2.1.1 Charged Item: basic communication

This expresses the rate for the basic communication.

The rate shall be expressed as:

- price per time unit and time unit (see clause C.2.2.1); or
- free of charge (see clause C.2.2.2); or
- flat rate (see clause C.2.2.3); or
- special charging code (see clause C.2.2.4); or
- not available (see clause C.2.2.6).

C.2.1.2 Charged Item: communication attempt

This expresses the cost of a communication attempt.

The cost shall be expressed as:

- free of charge (see clause C.2.2.2); or
- flat rate (see clause C.2.2.3); or
- special charging code (see clause C.2.2.4); or
- not available (see clause C.2.2.6).

C.2.1.3 Charged Item: communication setup

This expresses the cost of a communication setup.

The cost shall be expressed as:

- free of charge (see clause C.2.2.2); or
- flat rate (see clause C.2.2.3); or
- special charging code (see clause C.2.2.4); or
- not available (see clause C.2.2.6).

C.2.1.4 Charged Item: operation of services

This expresses the cost induced by the execution of services.

The cost shall be expressed as:

- price per time unit and time unit (see clause C.2.2.1); or
- free of charge (see clause C.2.2.2); or
- flat rate (see clause C.2.2.3); or
- special charging code (see clause C.2.2.4); or
- not available (see clause C.2.2.6).

C.2.1.5 Special Charging Arrangement

This expresses that a special charging arrangement exists for calculating the costs of the call.

The cost shall be expressed as:

- special charging code (see clause C.2.2.4).

C.2.2 Expressing Charging Rates

AOC-S can express charging rate as:

- price per time unit and time unit (see clause C.2.2.1); or
- free of charge (see clause C.2.2.2); or
- flat rate (see clause C.2.2.3); or
- special charging code (see clause C.2.2.4);
- charging unit (see clause C.2.2.5); or
- not available (see clause C.2.2.6).

C.2.2.1 Duration charge: Price per time unit, and unit time

Duration charge shall contain the following elements:

- currency identifier (see clause C.5.4); and
- currency amount (see clause C.5.5); and
- length of time unit (see clause C.5.6); and

- type of charging (see clause C.5.8).

and additionally it may contain the following element:

- granularity (see clause C.5.7).

C.2.2.2 Specific: free of charge

This rate represents a free charge.

C.2.2.3 Specific: flat rate

It shall be expressed as:

- currency identifier (see clause C.5.4);
- currency amount (see clause C.5.5).

C.2.2.4 Specific: special charging code N.

It shall be expressed as an integer between 1..10.

C.2.2.5 Charging unit

Charging unit shall contain the following elements:

- currency identifier (see clause C.5.4); and
- currency amount (see clause C.5.5).

C.2.2.6 Not available

Expresses that the charging information is not available.

C.3 AOC-D

The AOC-D service provides information about the recorded charges during the active phase of a call.

The information shall contain the following elements:

- type of charging information (see clause C.3.1); and
- recorded charges (see clause C.3.2).

and additionally it may contain the following element:

- billing identification (see clause C.3.3).

C.3.1 Type of charging information

Type of charging information shall have one of the following values:

- subtotal charges; or
- total charges.

C.3.2 Recorded charges

Recorded charges shall be expressed as one of the following elements:

- recorded number of currency units or charging units (see clause C.5.9); or
- free of charge; or
- not available.

C.3.3 Billing identification for AOC-D

It shall be expressed as one of the following values:

- normal charging (default); or
- reverse charging; or
- credit card charging.

C.4 AOC-E

The AOC-E service provides information about the recorded charges for a call when it is terminated.

The information consists of:

- recorded charges (see clause C.3.2)
- billing identification (see clause C.4.1).

C.4.1 Billing identification for AOC-E

It shall be expressed as one of the following values:

- normal charging (default); or
- reverse charging; or
- credit card charging;
- call forwarding unconditional;
- call forwarding busy;
- call forwarding noreply;
- call deflection;
- call transfer.

C.5 Common types/information elements

C.5.1 Time unit

Time unit shall be an integer value.

C.5.2 Decimal

Decimal shall be a decimal value.

C.5.3 Scale

The scale of time units shall have one of the following values:

- 0,01 s;
- 0,1 s;
- 1 s;
- 10 s;
- 1 min;
- 1 hour; or
- 24 hours.

C.5.4 Currency identifier

It shall be a string specifying the used currency or a charging unit identifier.

C.5.5 Currency amount

It shall be expressed as the value of decimal (see clause C.5.2).

C.5.6 Length of time unit

It shall be expressed as value of integer \times scale:

- time unit (see clause C.5.1); and
- scale (see clause C.5.3).

C.5.7 Granularity

This specifies the time unit applied for calculation of charges by the network.

It shall be expressed as value of integer \times scale:

- time unit (see clause C.5.1); and
- scale (see clause C.5.3).

C.5.8 Type of charging

Type of charging shall have one of the values of "step function" or "continuous".

C.5.9 Recorded number of currency units

It shall be expressed as:

- currency identifier (see clause C.5.4);

- currency amount (see clause C.5.5).

Annex D (normative): AOC XML Schema:

This annex defines the XML Schema to be used for providing the charging information described in annex C in the SIP methods to the served user.

The application/vnd.etsi.aoc+xml MIME type used to provide the charging information requested by the served user shall be coded as following described:

```
<?xml version="1.0" encoding="UTF-8"?>
<xs:schema targetNamespace="http://uri.etsi.org/ngn/params/xml/simservs/aoc"
xmlns="http://uri.etsi.org/ngn/params/xml/simservs/aoc" xmlns:xs="http://www.w3.org/2001/XMLSchema"
elementFormDefault="qualified" attributeFormDefault="unqualified">

  <xs:import namespace="http://www.w3.org/XML/1998/namespace"
schemaLocation="http://www.w3.org/2001/xml.xsd"/>
  <xs:annotation>
    <xs:documentation xml:lang="en">
      XML Schema Definition to the charging information related to the Advice of Charge simulation
      service.
    </xs:documentation>
  </xs:annotation>

  <xs:element name="aoc" type="aocType"/>

  <xs:complexType name="aocType">
    <xs:sequence>
      <xs:element name="aoc-s" type="aoc-sType" minOccurs="0"/>
      <xs:element name="aoc-d" type="aoc-dType" minOccurs="0"/>
      <xs:element name="aoc-e" type="aoc-eType" minOccurs="0"/>
      <xs:any namespace="##other" processContents="lax" minOccurs="0" maxOccurs="unbounded"/>
    </xs:sequence>
    <xs:anyAttribute namespace="##any" processContents="lax"/>
  </xs:complexType>

  <!-- xs:sequence is changed to xs:choice -->
  <xs:complexType name="aoc-sType">
    <xs:choice>
      <xs:element name="special-arrangement" type="xs:token"/>
      <xs:element name="charged-items" type="charged-itemsType"/>
      <xs:any namespace="##other" processContents="lax" minOccurs="0"
maxOccurs="unbounded"/>
    </xs:choice>
    <xs:anyAttribute namespace="##any" processContents="lax"/>
  </xs:complexType>

  <xs:complexType name="aoc-dType">
    <xs:sequence>
      <xs:element name="charging-info" type="charging-infoType" />
      <xs:element name="recorded-charges" type="recorded-chargesType" />
      <xs:element name="billing-id" type="billind-idType" minOccurs="0" />
      <xs:any namespace="##other" processContents="lax" minOccurs="0"
maxOccurs="unbounded"/>
    </xs:sequence>
    <xs:anyAttribute namespace="##any" processContents="lax"/>
  </xs:complexType>

  <xs:complexType name="aoc-eType">
    <xs:sequence>
      <xs:element name="recorded-charges" type="recorded-chargesType" />
      <xs:element name="billing-id" type="billind-idType" minOccurs="0" />
      <xs:any namespace="##other" processContents="lax" minOccurs="0"
maxOccurs="unbounded"/>
    </xs:sequence>
    <xs:anyAttribute namespace="##any" processContents="lax"/>
  </xs:complexType>

  <xs:complexType name="charged-itemsType">
    <xs:sequence>
      <xs:element name="basic" type="basicType" minOccurs="0"/>
      <xs:element name="communication-attempt" type="communication-attemptType"
minOccurs="0"/>
```

```

        <xs:element name="communication-setup" type="communication-setupType"
minOccurs="0"/>
        <xs:element name="services" type="servicesType" minOccurs="0" />
        <xs:any namespace="##other" processContents="lax" minOccurs="0"
maxOccurs="unbounded"/>
    </xs:sequence>
    <xs:anyAttribute namespace="##any" processContents="lax"/>
</xs:complexType>

<xs:complexType name="basicType">
    <xs:sequence>
        <xs:element name="price-time" type="price-timeType" minOccurs="0"
maxOccurs="unbounded" />
        <xs:element name="flat-rate" type="currency-id-amountType" minOccurs="0" />
        <xs:element name="free-charge" type="emptyType" minOccurs="0" />
        <xs:element name="special-code" type="xs:token" minOccurs="0" />
        <xs:element name="not-available" type="emptyType" minOccurs="0" />
    </xs:sequence>
</xs:complexType>

<xs:complexType name="communication-attemptType">
    <xs:sequence>
        <xs:element name="flat-rate" type="currency-id-amountType" minOccurs="0" />
        <xs:element name="free-charge" type="emptyType" minOccurs="0" />
        <xs:element name="special-code" type="xs:token" minOccurs="0" />
        <xs:element name="not-available" type="emptyType" minOccurs="0" />
    </xs:sequence>
</xs:complexType>

<xs:complexType name="communication-setupType">
    <xs:sequence>
        <xs:element name="flat-rate" type="currency-id-amountType" minOccurs="0" />
        <xs:element name="free-charge" type="emptyType" minOccurs="0" />
        <xs:element name="special-code" type="xs:token" minOccurs="0" />
        <xs:element name="not-available" type="emptyType" minOccurs="0" />
    </xs:sequence>
</xs:complexType>

<xs:complexType name="servicesType">
    <xs:sequence>
        <xs:element name="price-time" type="price-timeType" minOccurs="0" />
        <xs:element name="flat-rate" type="currency-id-amountType" minOccurs="0" />
        <xs:element name="free-charge" type="emptyType" minOccurs="0" />
        <xs:element name="special-code" type="xs:token" minOccurs="0" />
        <xs:element name="not-available" type="emptyType" minOccurs="0" />
    </xs:sequence>
</xs:complexType>

    <!-- length-time-unit: type="timeType" (another possibility is to keep length-time-unit with
type="xs:duration")
        granularity: type="timeType" (another possibility is type="xs:duration")
        (xs:duration: the minimum resolution is second)
-->
<xs:complexType name="price-timeType">
    <xs:sequence>
        <xs:element name="currency-id" type="xs:token" minOccurs="0"/>
        <!-- The currency-id shall be coded according to ISO 4217 [3] or set to the value
"UNIT" for the sending of charging units. -->
        <xs:element name="currency-amount" type="xs:decimal" minOccurs="0" />
        <xs:element name="length-time-unit" type="timeType" minOccurs="0" />
        <xs:element name="charging-type" type="charging-typeType" minOccurs="0" />
        <xs:element name="granularity" type="timeType" minOccurs="0" />
    </xs:sequence>
</xs:complexType>

<xs:complexType name="currency-id-amountType">
    <xs:sequence>
        <xs:element name="currency-id" type="xs:token" minOccurs="0"/>
        <!-- The currency-id shall be coded according to ISO 4217 [3] or set to the value
"UNIT" for the sending of charging units. -->
        <xs:element name="currency-amount" type="xs:decimal" minOccurs="0" />
    </xs:sequence>
</xs:complexType>

<!-- timeType is represented with time-unit (unsigned int) * scale (enum) -->
<xs:complexType name="timeType">
    <xs:sequence>
        <xs:element name="time-unit" type="xs:unsignedInt"/>

```

```

        <xs:element name="scale" type="scaleType"/>
    </xs:sequence>
</xs:complexType>

<xs:simpleType name="scaleType">
    <xs:restriction base="xs:token">
        <xs:enumeration value="one-hundreth-second"/>
        <xs:enumeration value="one-tenth-second"/>
        <xs:enumeration value="one-second"/>
        <xs:enumeration value="ten-seconds"/>
        <xs:enumeration value="one-minute"/>
        <xs:enumeration value="one-hour"/>
        <xs:enumeration value="twenty-four-hours"/>
    </xs:restriction>
</xs:simpleType>
<!-- end of timeType definition -->

    <xs:complexType name="emptyType">
        <xs:complexContent>
            <xs:restriction base="xs:anyType"/>
        </xs:complexContent>
    </xs:complexType>

<!-- simplified -->
<xs:simpleType name="charging-infoType">
    <xs:restriction base="xs:token">
        <xs:enumeration value="total" />
        <xs:enumeration value="subtotal" />
    </xs:restriction>
</xs:simpleType>

<!-- xs:sequence is changed to xs:choice -->
<xs:complexType name="recorded-chargesType">
    <xs:choice>
        <xs:element name="recorded-currency-units" type="currency-id-amountType"/>
        <xs:element name="free-charge" type="emptyType"/>
        <xs:element name="not-available" type="emptyType"/>
    </xs:choice>
</xs:complexType>

<xs:simpleType name="billind-idType">
    <xs:restriction base="xs:string">
        <xs:enumeration value="normal-charging"/>
        <xs:enumeration value="reverse-charging"/>
        <xs:enumeration value="credit-card"/>
        <xs:enumeration value="cfu"/>
        <xs:enumeration value="cfb"/>
        <xs:enumeration value="cfnr"/>
        <xs:enumeration value="cd"/>
        <xs:enumeration value="ct"/>
    </xs:restriction>
</xs:simpleType>

    <xs:simpleType name="charging-typeType">
        <xs:restriction base="xs:string">
            <xs:enumeration value="step-functor" />
            <xs:enumeration value="continuous" />
        </xs:restriction>
    </xs:simpleType>
</xs:schema>

```

Annex E (informative): Change history

Change history							
Date	TSG #	TSG Doc.	CR	Rev	Subject/Comment	Old	New
2007-03					Publication as ETSI TS 183 047		2.1.1
2007-12					Conversion to 3GPP TS 24.447		2.1.2
2008-03	CT#39	CP-080092			Based on the decision in CT#39 version 8.0.0 created by MCC	2.1.2	8.0.0