

3GPP TS 24.410 V8.1.0 (2012-12)

Technical Specification

**3rd Generation Partnership Project;
Technical Specification Group Core Network and Terminals;
Telecommunications and Internet converged Services and
Protocols for Advanced Networking (TISPAN);
NGN Signalling Control Protocol;
Communication HOLD (HOLD) PSTN/ISDN simulation services;
Protocol specification
(Release 8)**



The present document has been developed within the 3rd Generation Partnership Project (3GPP™) and may be further elaborated for the purposes of 3GPP.

The present document has not been subject to any approval process by the 3GPP Organizational Partners and shall not be implemented. This Specification is provided for future development work within 3GPP only. The Organizational Partners accept no liability for any use of this Specification. Specifications and reports for implementation of the 3GPP™ system should be obtained via the 3GPP Organizational Partners' Publications Offices.

Keywords

hold, supplementary service

3GPP

Postal address

3GPP support office address

650 Route des Lucioles - Sophia Antipolis
Valbonne - FRANCE
Tel.: +33 4 92 94 42 00 Fax: +33 4 93 65 47 16

Internet

<http://www.3gpp.org>

Copyright Notification

No part may be reproduced except as authorized by written permission.
The copyright and the foregoing restriction extend to reproduction in all media.

© 2012, 3GPP Organizational Partners (ARIB, ATIS, CCSA, ETSI, TTA, TTC).
All rights reserved.

UMTS™ is a Trade Mark of ETSI registered for the benefit of its members
3GPP™ is a Trade Mark of ETSI registered for the benefit of its Members and of the 3GPP Organizational Partners
LTE™ is a Trade Mark of ETSI registered for the benefit of its Members and of the 3GPP Organizational Partners
GSM® and the GSM logo are registered and owned by the GSM Association

Contents

Foreword	5
1 Scope	6
2 References.....	6
3 Definitions and abbreviations	7
3.1 Definitions	7
3.2 Abbreviations.....	7
4 Communication Hold (HOLD).....	7
4.1 Introduction	7
4.2 Description.....	7
4.2.1 General description	7
4.3 Operational requirements	7
4.3.1 Provision/withdrawal.....	7
4.3.2 Requirements on the originating network side.....	8
4.3.3 Requirements in the network.....	8
4.3.4 Requirements on the terminating network side.....	8
4.4 Coding requirements	8
4.5 Signalling requirements	8
4.5.1 Activation/deactivation	8
4.5.2 Invocation and operation.....	8
4.5.2.1 Actions at the invoking UE.....	8
4.5.2.2 Actions at the P-CSCF of the invoking UE.....	9
4.5.2.3 Actions at the S-CSCF	9
4.5.2.4 Actions at the AS of the invoking UE	9
4.5.2.5 Actions at the incoming I-CSCF	9
4.5.2.6 Actions at the outgoing IBCF	9
4.5.2.7 Actions at the incoming IBCF	9
4.5.2.8 Actions at the P-CSCF of the held UE.....	9
4.5.2.9 Actions at the held UE	9
4.6 Interaction with other services	9
4.6.1 Communication Hold (HOLD)	9
4.6.2 Terminating Identification Presentation (TIP).....	10
4.6.3 Terminating Identification Restriction (TIR)	10
4.6.4 Originating Identification Presentation (OIP)	10
4.6.5 Originating identification restriction (OIR).....	10
4.6.6 Conference calling (CONF)	10
4.6.7 Communication DIVersion services (CDIV)	10
4.6.8 Malicious Communication IDentification (MCID).....	10
4.6.9 Anonymous Communication Rejection and Communication Barring (ACR/CB)	10
4.6.10 Explicit Communication Transfer (ECT).....	10
4.7 Interactions with other networks	10
4.7.1 Interaction with PSTN/ISDN	10
4.7.2 Interaction with PSTN/ISDN Emulation	10
4.7.3 Interaction with external IP networks	11
4.8 Parameter values (timers).....	11
Annex A (informative): Signalling Flows.....	12
A.1 HOLD communication	12
A.1.1 HOLD communication without announcement	12
A.1.2 HOLD communication with announcement.....	13
A.2 RESUME Communication.....	14
A.2.1 RESUME communication without announcement.....	14
A.2.2 RESUME communication with announcement	15

Annex B (informative): **Change history.....16**

Foreword

This Technical Specification (TS) was produced by ETSI Technical Committee Telecommunications and Internet converged Services and Protocols for Advanced Networking (TISPAN) and originally published as ETSI TS 183 010 [7]. It was transferred to the 3rd Generation Partnership Project (3GPP) in December 2007.

The contents of the present document are subject to continuing work within the TSG and may change following formal TSG approval. Should the TSG modify the contents of the present document, it will be re-released by the TSG with an identifying change of release date and an increase in version number as follows:

Version x.y.z

where:

- x the first digit:
 - 1 presented to TSG for information;
 - 2 presented to TSG for approval;
 - 3 or greater indicates TSG approved document under change control.
- y the second digit is incremented for all changes of substance, i.e. technical enhancements, corrections, updates, etc.
- z the third digit is incremented when editorial only changes have been incorporated in the document.

1 Scope

The present document specifies the, stage three, Protocol Description of the Communication Hold (HOLD) services, based on stages one and two of the ISDN Hold (HOLD) supplementary services. Within the Next Generation Network (NGN) the stage 3 description is specified using the IP-Multimedia Call Control Protocol based on Session Initiation Protocol (SIP) and Session Description Protocol (SDP).

2 References

The following documents contain provisions which, through reference in this text, constitute provisions of the present document.

- References are either specific (identified by date of publication, edition number, version number, etc.) or non-specific.
- For a specific reference, subsequent revisions do not apply.
- For a non-specific reference, the latest version applies. In the case of a reference to a 3GPP document (including a GSM document), a non-specific reference implicitly refers to the latest version of that document *in the same Release as the present document*.

Referenced documents which are not found to be publicly available in the expected location might be found at <http://docbox.etsi.org/Reference>.

NOTE: While any hyperlinks included in this clause were valid at the time of publication ETSI cannot guarantee their long term validity.

- [1] ETSI ES 283 003: "Telecommunications and Internet converged Services and Protocols for Advanced Networking (TISPAN); IP Multimedia Call Control Protocol based on Session Initiation Protocol (SIP) and Session Description Protocol (SDP) Stage 3 [3GPP TS 24.229 (Release 7), modified]".
- [2] ETSI ES 283 027: " Telecommunications and Internet converged Services and Protocols for Advanced Networking (TISPAN); Endorsement of the SIP-ISUP Interworking between the IP Multimedia (IM) Core Network (CN) subsystem and Circuit Switched (CS) networks [3GPP TS 29.163 (Release 7), modified]".
- [3] ETSI TS 129 163: "Digital cellular telecommunications system (Phase 2+); Universal Mobile Telecommunications System (UMTS); Interworking between the IP Multimedia (IM) Core Network (CN) subsystem and Circuit Switched (CS) networks (3GPP TS 29.163)".
- [4] IETF RFC 3264 (2002): "An Offer/Answer Model with the Session Description Protocol (SDP)".
- [5] ETSI TS 181 002: "Telecommunications and Internet converged Services and Protocols for Advanced Networking (TISPAN); Multimedia Telephony with PSTN/ISDN simulation services".
- [6] ETSI TS 183 028: "Telecommunications and Internet converged Services and Protocols for Advanced Networking (TISPAN); Common Basic Communication procedures; Protocol specification".
- [7] ETSI TS 183 010 V1.2.2: "Telecommunications and Internet converged Services and Protocols for Advanced Networking (TISPAN); NGN Signalling Control Protocol; Communication HOLD (HOLD) PSTN/ISDN simulation services; Protocol specification".

3 Definitions and abbreviations

3.1 Definitions

For the purposes of the present document, the terms and definitions given in TS 181 002 [5] apply.

3.2 Abbreviations

For the purposes of the present document, the following abbreviations apply:

ACR/CB	Anonymous Communication Rejection and Communication Barring
AS	SIP Application Server
CDIV	Communication DIVersion
CSCF	Call Session Control Function
ECT	Explicit Communication Transfer
HOLD	communication session HOLD
IBCF	Interconnect Border Control Function
I-CSCF	Interrogation-CSCF
IMS	IP Multimedia Subsystem
IP	Internet Protocol
ISDN	Integrated Service Data Network
MCID	Malicious Communication IDentification
NGN	Next Generation Network
OIP	Originating Identification Presentation
OIR	Originating Identification Restriction
P-CSCF	Proxy-CSCF
PSTN	Public Switched Telephone Network
S-CSCF	Serving-CSCF
SDP	Session Description Protocol
SIP	Session Initiation Protocol
TIP	Terminating Identification Presentation
TIR	Terminating Identification Restriction
UE	User Equipment

4 Communication Hold (HOLD)

4.1 Introduction

Not applicable.

4.2 Description

4.2.1 General description

The Communication Hold supplementary service enables a user to suspend the media stream(s) of an established IP multimedia session, and resume the media stream(s) at a later time.

4.3 Operational requirements

4.3.1 Provision/withdrawal

The HOLD service that includes announcements shall be provided after prior arrangement with the service provider.

4.3.2 Requirements on the originating network side

No specific requirements are needed in the network.

4.3.3 Requirements in the network

No specific requirements are needed in the network.

4.3.4 Requirements on the terminating network side

No specific requirements are needed in the network.

4.4 Coding requirements

No specific coding requirements are needed.

4.5 Signalling requirements

4.5.1 Activation/deactivation

The HOLD service is activated at provisioning and deactivated at withdrawal.

Not applicable.

4.5.1A Registration/erasure

The HOLD service requires no registration. Erasure is not applicable.

4.5.1B Interrogation

Interrogation of HOLD is not applicable.

4.5.2 Invocation and operation

4.5.2.1 Actions at the invoking UE

In addition to the application of basic call procedures according to ES 283 003 [1] the following procedures shall be applied at the invoking UE in accordance with RFC 3264 [4].

A UE shall not invoke the HOLD service on a dialog associated with an emergency call the UE has initiated.

If individual media streams are affected:

- for each media stream that shall be held, the invoking UE shall generate a new SDP offer that contains:
 - an "inactive" SDP attribute if the stream was previously set to "recvonly" media stream; or
 - a "sendonly" SDP attribute if the stream was previously set to "sendrecv" media stream; or
- for each media stream that shall be resumed, the invoking UE shall generate a new SDP offer that contains:
 - a "recvonly" SDP attribute if the stream was previously an inactive media stream; or
 - a "sendrecv" SDP attribute if the stream was previously a sendonly media stream, or the attribute may be omitted, since sendrecv is the default.

If all the media streams in the SDP are affected:

- for the media streams that shall be held, the invoking UE shall generate a session level direction attribute in the SDP that is set to:
 - "inactive" if the streams were previously set to "recvonly" media streams; or
 - "sendonly" if the streams were previously set to "sendrecv" media streams; or
- for the media streams that shall be resumed, the invoking UE shall generate a session level direction attribute in the SDP that is set to:
 - "recvonly" if the streams were previously inactive media streams; or
 - "sendrecv" if the streams were previously sendonly media streams, or the attribute may be omitted, since sendrecv is the default.

Then the UE shall send the generated SDP offer in a re-INVITE (or UPDATE) request to the held UE.

4.5.2.2 Actions at the P-CSCF of the invoking UE

Basic communication procedures according to ES 283 003 [1] shall apply.

4.5.2.3 Actions at the S-CSCF

Basic communication procedures according to ES 283 003 [1] shall apply.

4.5.2.4 Actions at the AS of the invoking UE

As a network option the AS of the invoking UE shall initiate the procedures for the provision of an announcement to the held user in accordance with TS 183 028 [6].

4.5.2.5 Actions at the incoming I-CSCF

Basic communication procedures according to ES 283 003 [1] shall apply.

4.5.2.6 Actions at the outgoing IBCF

Basic communication procedures according to ES 283 003 [1] shall apply.

4.5.2.7 Actions at the incoming IBCF

Basic communication procedures according to ES 283 003 [1] shall apply.

4.5.2.8 Actions at the P-CSCF of the held UE

Basic communication procedures according to ES 283 003 [1] shall apply.

4.5.2.9 Actions at the held UE

Basic communication procedures according to ES 283 003 [1] shall apply.

4.6 Interaction with other services

4.6.1 Communication Hold (HOLD)

No impact, i.e. neither service shall affect the operation of the other service.

4.6.2 Terminating Identification Presentation (TIP)

No impact, i.e. neither service shall affect the operation of the other service.

4.6.3 Terminating Identification Restriction (TIR)

No impact, i.e. neither service shall affect the operation of the other service.

4.6.4 Originating Identification Presentation (OIP)

No impact, i.e. neither service shall affect the operation of the other service.

4.6.5 Originating identification restriction (OIR)

No impact, i.e. neither service shall affect the operation of the other service.

4.6.6 Conference calling (CONF)

If a participant of a conference invokes the HOLD service, it is not desirable to provide an announcement to the conference. Therefore if a communication to a remote URI shall be held by sending a re-INVITE (or UPDATE) request which includes the "isfocus" feature parameter in the Contact header, the AS of the invoking UE shall not initiate the procedures for the provision of an announcement to the held user.

4.6.7 Communication DIVersion services (CDIV)

No impact, i.e. neither service shall affect the operation of the other service.

4.6.8 Malicious Communication IDentification (MCID)

No impact, i.e. neither service shall affect the operation of the other service.

4.6.9 Anonymous Communication Rejection and Communication Barring (ACR/CB)

No impact, i.e. neither service shall affect the operation of the other service.

4.6.10 Explicit Communication Transfer (ECT)

No impact, i.e. neither service shall affect the operation of the other service.

4.7 Interactions with other networks

4.7.1 Interaction with PSTN/ISDN

The procedures of ETSI TS 129 163 [3], clause 7.4.10 shall apply with the additions of ES 283 027 [2].

NOTE: If the Hold and Resume procedures are initiated from the PSTN/ISDN network side, only the UPDATE request is used to signal the new SDP, in accordance with ES 283 003 [1].

4.7.2 Interaction with PSTN/ISDN Emulation

For Further Study.

4.7.3 Interaction with external IP networks

The procedures of ES 283 003 [1] shall apply.

4.8 Parameter values (timers)

Not applicable.

Annex A (informative): Signalling Flows

A.1 HOLD communication

Assumption is that a session has been established between UE-A and UE-B using basic communication procedures according to ES 283 003 [1], therefore the following signalling flows do not apply to the initial INVITE.

A.1.1 HOLD communication without announcement

The following diagram shows a communication session put on hold using a reINVITE request, note that the same can be achieved by sending an UPDATE request.

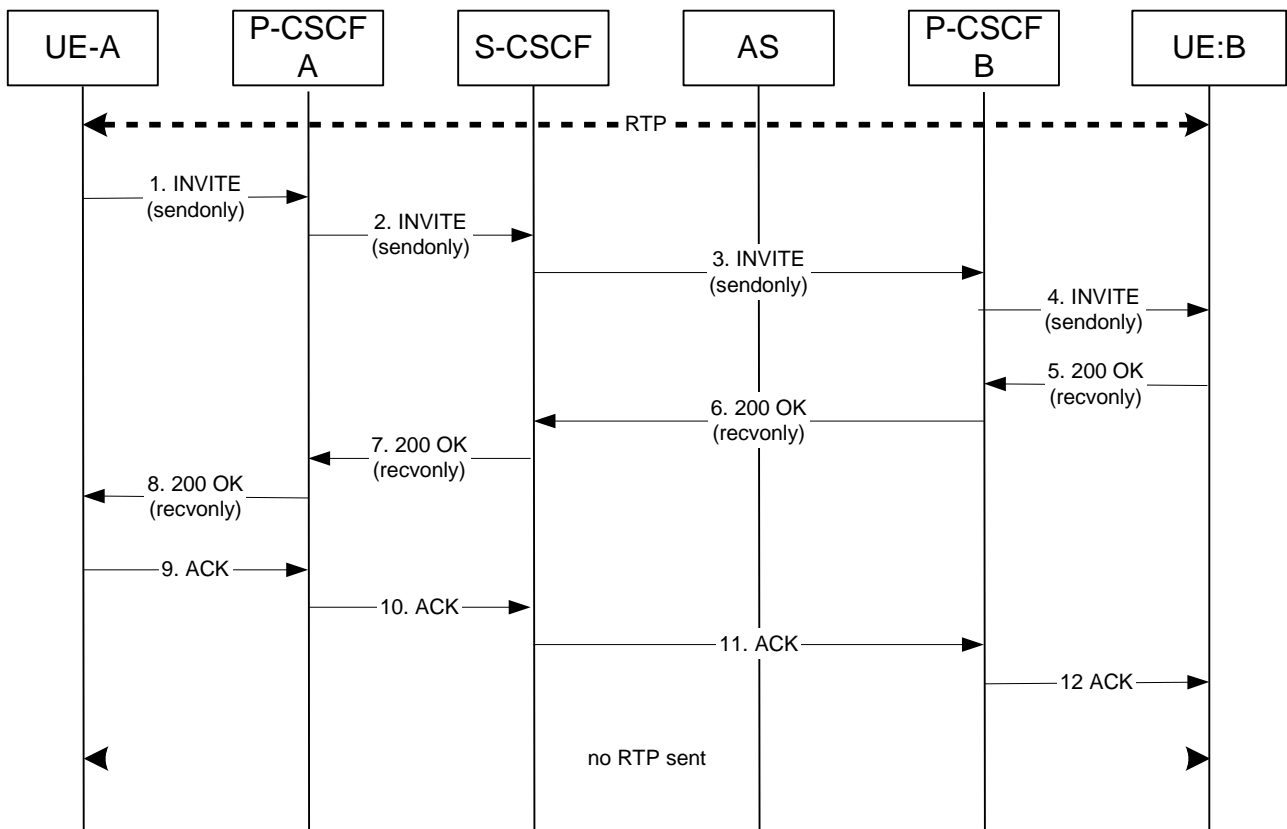

Figure A.1.1.1: HOLD communication without announcement to the held user

1. UE-A sends an INVITE to UE-B to hold the session. Hold is done by changing the SDP attribute:

- "a=sendonly", if the stream was previously a sendrecv media stream;
- "a=inactive", if the stream was previously a recvonly media stream.

A.1.2 HOLD communication with announcement

The following diagram shows a communication session put on hold using a reINVITE request, note that the same can be achieved by sending an UPDATE request.

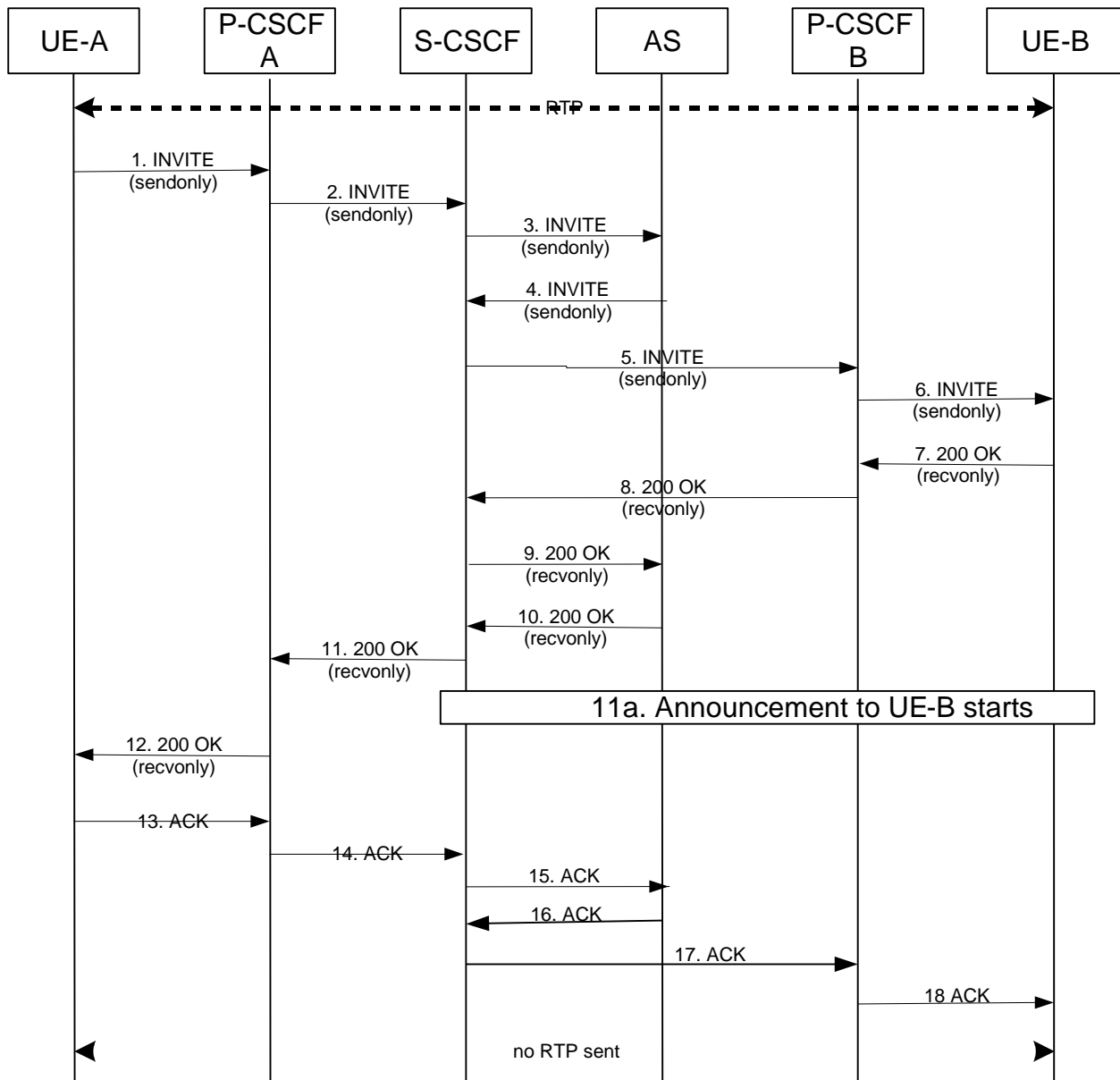

Figure A.1.2.1: HOLD communication with announcement to the held user

1. UE-A sends an INVITE to UE-B to hold the session. Hold is done by changing the SDP attribute:

- "a=sendonly", if the stream was previously a sendrecv media stream;
- "a=inactive", if the stream was previously a recvonly media stream.

A.2 RESUME Communication

A.2.1 RESUME communication without announcement

The following diagram shows how a communication session is resumed using a reINVITE request, note that the same can be achieved by sending an UPDATE request.

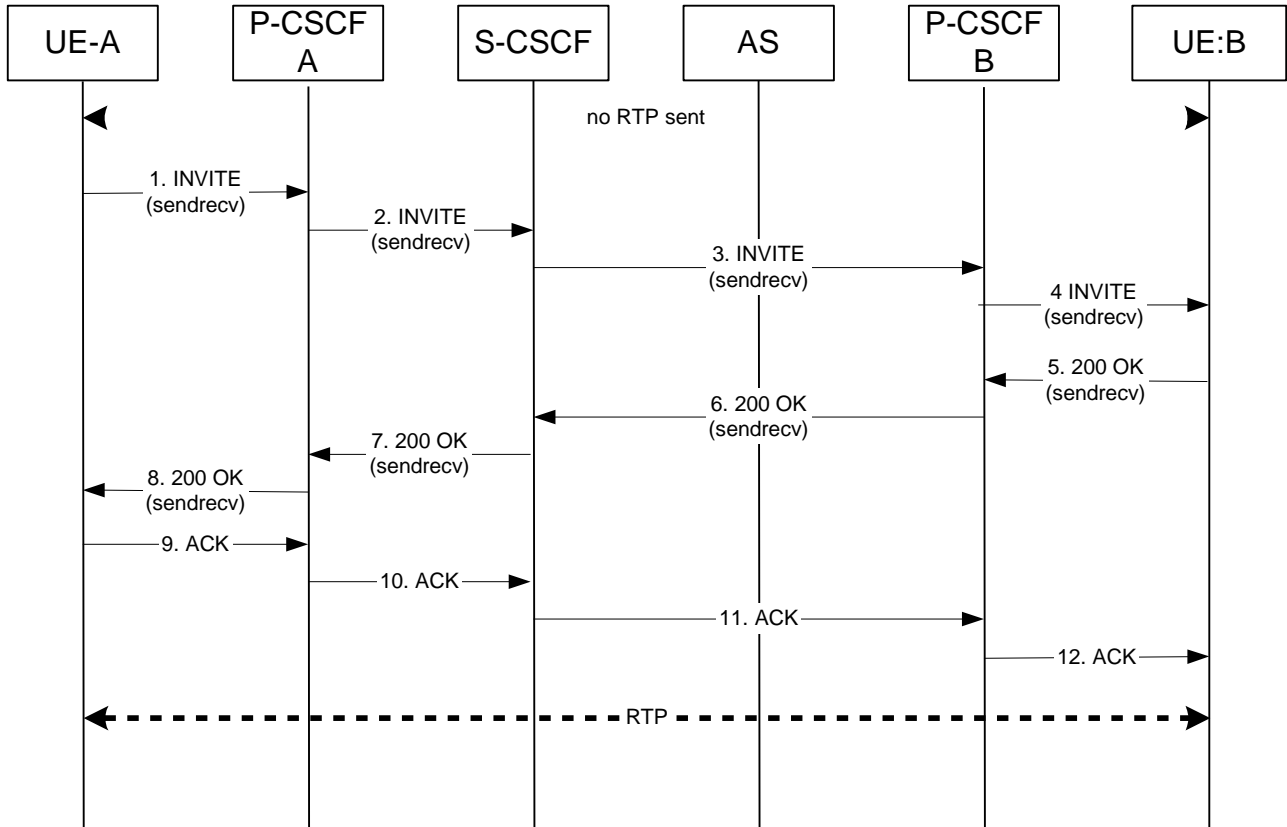

Figure A.2.1.1: RESUME communication without announcement to the held user

1. UE-A sends an INVITE to UE-B to resume the session. Resume is done by changing the SDP attribute:

- "a=sendrecv", if the stream was previously a recvonly media stream, or the attribute may be omitted, since sendrecv is the default;
- "a=recvonly", if the stream was previously an inactive media stream.

A.2.2 RESUME communication with announcement

The following diagram shows how a communication session is resumed using a reINVITE request, note that the same can be achieved by sending an UPDATE request.

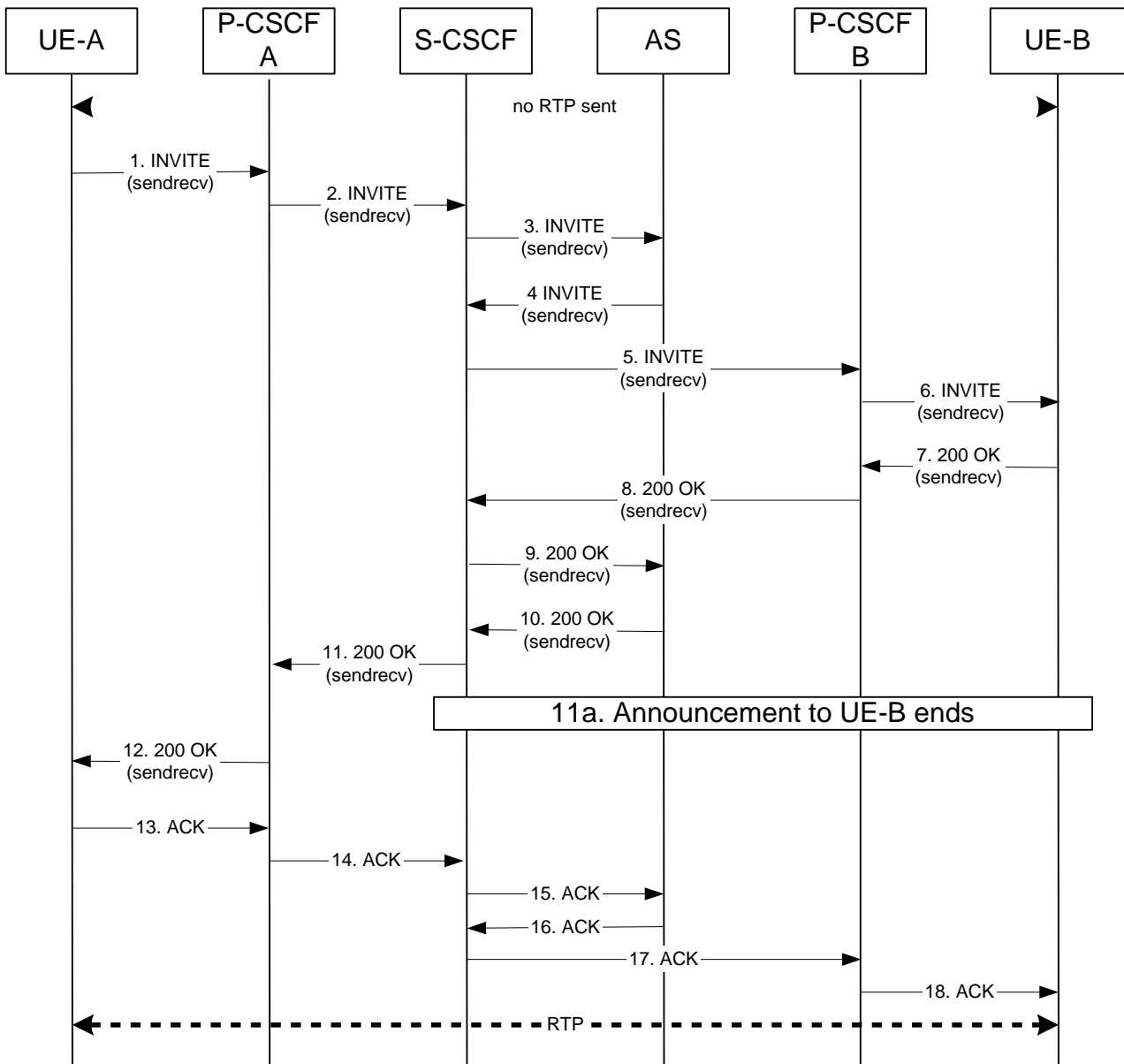

Figure A.2.2.1: RESUME communication with announcement to the held user

1. UE-A sends an INVITE to UE-B to resume the session. Resume is done by changing the SDP attribute:

- "a=sendrecv", if the stream was previously a recvonly media stream, or the attribute may be omitted, since sendrecv is the default;
- "a=recvonly", if the stream was previously an inactive media stream.

Annex B (informative): Change history

Change history							
Date	TSG #	TSG Doc.	CR	Rev	Subject/Comment	Old	New
2005-08					Publication as ETSI TS 183 010		1.1.1
2006-04					Publication as ETSI TS 183 010		1.2.1
2007-04					Publication as ETSI TS 183 010		1.2.2
2007-12					Conversion to 3GPP TS 24.410		1.2.3
2008-03	CT#39	CP-080080			Version 1.2.3 approved in CT#39 and version 7.0.0 created by MCC	1.2.3	7.0.0
2008-03					Based on the decision in CT#39 version 8.0.0 was created by MCC	7.0.0	8.0.0
2012-12	CT#58	CP-120778	0001	1	Emergency call HOLD suppression	8.0.0	8.1.0