

3GPP TS 24.002 V11.0.0 (2012-09)

Technical Specification

3rd Generation Partnership Project; Technical Specification Group Core Network and Terminals; GSM - UMTS Public Land Mobile Network (PLMN) Access Reference Configuration (Release 11)



The present document has been developed within the 3rd Generation Partnership Project (3GPP™) and may be further elaborated for the purposes of 3GPP. The present document has not been subject to any approval process by the 3GPP Organisational Partners and shall not be implemented. This Specification is provided for future development work within 3GPP only. The Organisational Partners accept no liability for any use of this Specification. Specifications and reports for implementation of the 3GPP™ system should be obtained via the 3GPP Organisational Partners' Publications Offices.

Keywords

GSM, UMTS, network, architecture

3GPP

Postal address

3GPP support office address

650 Route des Lucioles - Sophia Antipolis
Valbonne - FRANCE
Tel.: +33 4 92 94 42 00 Fax: +33 4 93 65 47 16

Internet

<http://www.3gpp.org>

Copyright Notification

No part may be reproduced except as authorized by written permission.
The copyright and the foregoing restriction extend to reproduction in all media.

© 2012, 3GPP Organizational Partners (ARIB, ATIS, CCSA, ETSI, TTA, TTC).
All rights reserved.

UMTS™ is a Trade Mark of ETSI registered for the benefit of its members
3GPP™ is a Trade Mark of ETSI registered for the benefit of its Members and of the 3GPP Organizational Partners
LTE™ is a Trade Mark of ETSI currently being registered for the benefit of its Members and of the 3GPP Organizational Partners
GSM® and the GSM logo are registered and owned by the GSM Association

Contents

Foreword	4
1 Scope	5
1.1 References.....	5
1.2 Abbreviations	6
2 General definitions	6
2.1 Reference Configurations.....	7
2.2 Functional Groups	7
2.3 Reference Points	7
2.4 Interface Points	7
2.5 Terminal Definitions	7
3 Reference Configuration	8
3.0 General	8
3.1 Mobile Termination (MT).....	9
3.2 Void	10
4 Physical Realisation	10
Annex A (informative): Change history.....	11

Foreword

This Technical Specification has been produced by the 3rd Generation Partnership Project (3GPP).

The contents of the present document are subject to continuing work within the TSG and may change following formal TSG approval. Should the TSG modify the contents of the present document, it will be re-released by the TSG with an identifying change of release date and an increase in version number as follows:

Version x.y.z

where:

- x the first digit:
 - 1 presented to TSG for information;
 - 2 presented to TSG for approval;
 - 3 or greater indicates TSG approved document under change control.
- y the second digit is incremented for all changes of substance, i.e. technical enhancements, corrections, updates, etc.
- z the third digit is incremented when editorial only changes have been incorporated in the document.

1 Scope

The present document describes the reference configuration for access to a PLMN.

A user accesses a PLMN via a number of interfaces, including the MS-BS (in A/Gb mode and GERAN Iu mode), UE-UTRAN (in UTRAN Iu mode) and UE-E-UTRAN interface. The purpose of this document is to indicate the possible access arrangements that may be used in conjunction with the MS-BS (in A/Gb mode and GERAN Iu mode), UE-UTRAN (in UTRAN Iu mode) and UE-E - UTRAN interface.

1.1 References

The following documents contain provisions which, through reference in this text, constitute provisions of the present document.

- References are either specific (identified by date of publication, edition number, version number, etc.) or non-specific.
- For a specific reference, subsequent revisions do not apply.
- For a non-specific reference, the latest version applies. In the case of a reference to a 3GPP document (including a GSM document), a non-specific reference implicitly refers to the latest version of that document *in the same Release as the present document*.

[1]	Void.
[2]	Void.
[3]	Void.
[4]	Void.
[5]	Void.
[6]	Void.
[7]	Void.
[8]	Void.
[9]	Void.
[10]	Void.
[11]	Void.
[12]	Void.
[13]	Void.
[14]	3GPP TS 44.021: "Rate adaption on the Mobile Station - Base Station System (MS - BSS) interface".
[15]	Void.
[16]	Void.
[17]	Void.
[18]	Void.
[19]	Void.
[20]	Void.

- [21] Void.
- [22] Void.
- [23] Void.
- [24] Void.
- [25] Void.
- [26] Void.
- [27] Void.
- [28] Void.
- [29] Void.
- [30] Void.
- [31] Void.
- [32] Void.
- [33] 3GPP TS 27.001: "General on Terminal Adaptation Functions (TAF) for Mobile Stations (MS)".
- [34] 3GPP TS 27.002: "Terminal Adaptation Functions (TAF) for services using asynchronous bearer capabilities".
- [35] 3GPP TS 27.003: "Terminal Adaptation Functions (TAF) for services using synchronous bearer capabilities".
- [36] Void.
- [37] Void.
- [38] Void.
- [39] 3GPP TR 21.905: "Vocabulary for 3GPP Specifications".
- [40] Void.
- [41] 3GPP TS 25.322: "Radio Link Control (RLC) Protocol Specification".
- [42] ITU-T Recommendation V.24 (1996): "List of definitions for interchange circuits between data terminal equipment (DTE) and data circuit-terminating equipment (DCE)".
- [43] ITU-T Recommendation V.28 (1993): "Electrical characteristics for unbalanced double-current interchange circuits".
- [44] Infrared Data Association IrDA: "IrPHY Physical layer signalling standard".
- [45] Personal Computer Memory Card Association: "PCMCIA 2.1 or PC-Card 3.0 electrical specification or later revisions".
- [46] Void.

1.2 Abbreviations

Abbreviations used in the present document are listed in 3GPP TR 21.905 [39].

2 General definitions

The following definitions 2.1-2.3 are based on those used for ISDN.

2.1 Reference Configurations

Reference Configurations are conceptual configurations useful in identifying access arrangements to a network. Two concepts are used in defining reference configurations:

reference points and functional groups.

2.2 Functional Groups

Functional Groups are sets of functions which may be needed in network access arrangements. In a particular access arrangement, specific functions in a functional group may or may not be present. Specific functions in a functional group may be performed in one or more pieces of equipment.

2.3 Reference Points

Reference Points are the conceptual points dividing functional groups. In a specific access arrangement, a reference point may correspond to a physical interface between pieces of equipment, or there may not be any physical interface corresponding to the reference point.

2.4 Interface Points

Interface Points are reference points within a PLMN at which a 3GPP specified interface is always identified.

2.5 Terminal Definitions

The term 'mobile station' (MS) in the present document is synonymous with the term 'user equipment' (UE) in 3G terminology as defined in 3GPP TR 21.905 [39].

The term 'TE2' in the present document is synonymous with the term 'TE' in 3G terminology as defined in 3GPP TR 21.905 [39].

The term 'MT2' in the present document is synonymous with the term 'MT' in 3G terminology as defined in 3GPP TR 21.905 [39].

3 Reference Configuration

3.0 General

The reference configuration for PLMN (in A/Gb mode and GERAN Iu mode) access interfaces is shown in figure 1.

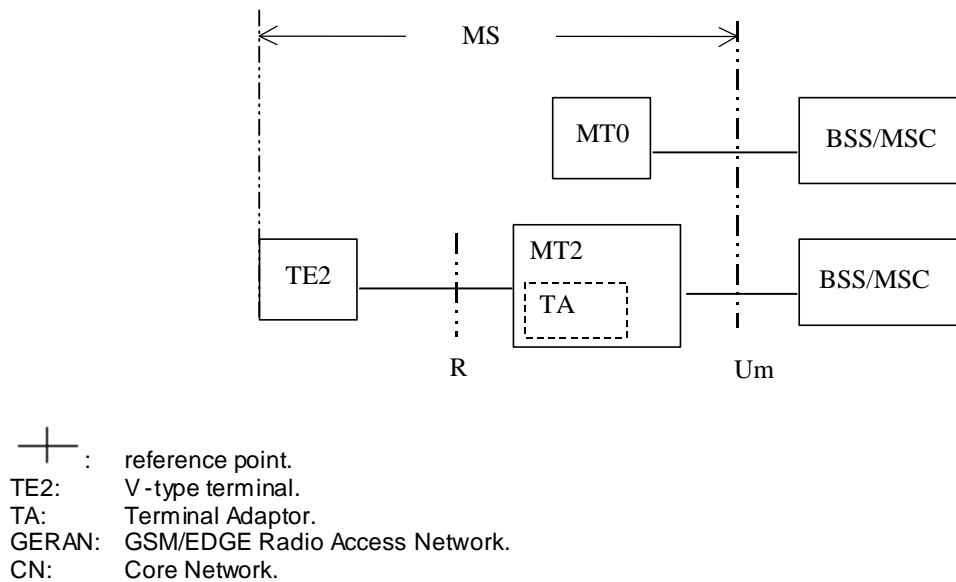

Figure 1: PLMN Access Reference Configuration (in A/Gb mode and GERAN Iu mode)

There are two types of MT:

- MT0 includes functions belonging to the functional group MT, with support of no terminal interfaces.
- MT2 includes functions belonging to the functional group MT, and with an interface that complies with the 3GPP TS 27.00z series Terminal Adaptation Function specifications [33], [34], [35]. Accordingly, the interchange circuit mapping at the MT2 to TE interface shall comply with the ITU-T V.24 [42] recommendation; while the physical implementation shall conform either to the ITU-T V.28 [43], or to the IrDA IrPHY Physical signalling standard specification [44], or to the PCMCIA 2.1 [45], or to the PC-Card 3.0 [45], electrical specification or to later revisions.

The MT plus any TE constitutes the Mobile Station, MS.

The terminal equipment functional groups TE2 and TA are conceptually the same functional groups as those in the ISDN.

The reference configuration for PLMN (Iu mode) access interfaces is shown in figure 2.

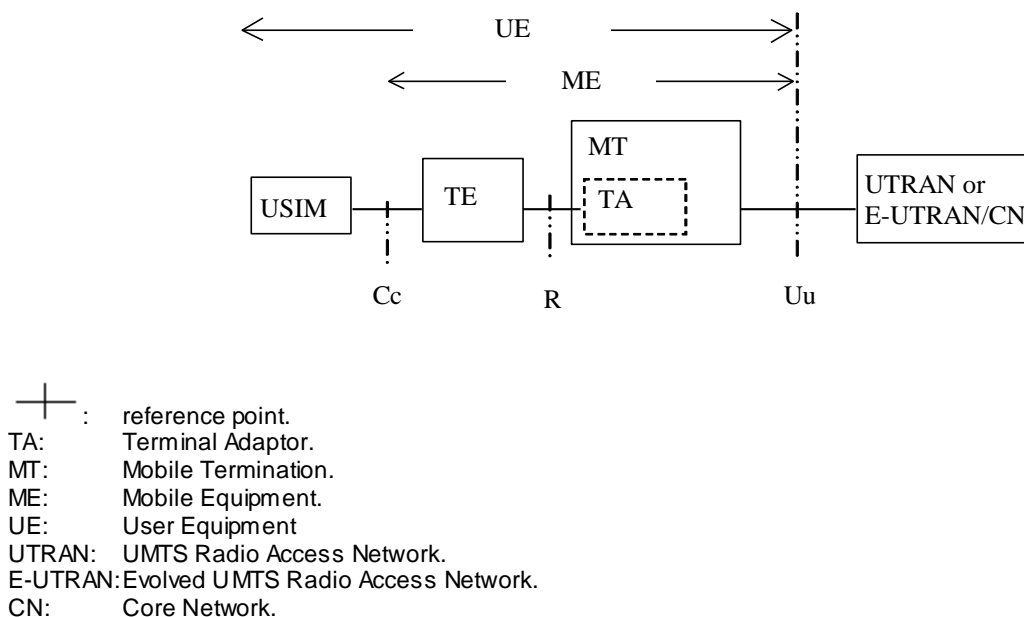

Figure 2: PLMN Access Reference Configuration (UTRAN Iu mode or E-UTRAN)

There is no reference point identified for the TA Function. The TA Function is considered as a part of the Mobile Termination and with an interface that complies with the 3GPP TS 27.00z series Terminal Adaptation Function specifications [33], [34], [35].

3.1 Mobile Termination (MT)

The MT performs the following functions, which performs the following functions:

- radio transmission termination;
- radio transmission channel management;
- terminal capabilities, including presentation of a man-machine interface to a user;
- speech encoding/decoding;
- error protection for all information sent across the radio path. This includes FEC (forward error correction) and, for signalling and user data (except for transparent data services), ARQ (automatic request for retransmission);
- flow control of signalling and mapping of user signalling to/from PLMN access signalling;
- flow control of user data (except for transparent data services) and mapping of flow control for asynchronous transparent data services;
- rate adaptation of user data (see 3GPP TS 44.021[14]) and data formatting for the transmission SAP (3GPP TS 25.322 [41]);
- multiple terminal support;
- mobility management.

3.2 Void

4 Physical Realisation

In a PLMN, the reference point Um/Uu is an interface point, i.e. it is always implemented as a physical interface (according to 3GPP Technical Specifications in the 44, 45, 24, 25 and 36 series). The R reference point may be optionally implemented as physical interface. The implementation of interfaces at this reference point is according to 3GPP TS 27.001 [33], 3GPP TS 27.002 [34] and 3GPP TS 27.003 [35].

Figure 3 gives examples of configurations illustrating combinations of physical interfaces at the R reference point. The examples shown are not exhaustive, but only serve to illustrate possible implementations of the respective functional blocks.

Example (a) of figure 3 illustrates a fully integrated MS including data terminal functions within the mobile station equipment.

Example (c) of figure 3 illustrates the connection of a TE2 by an ITU-T V series interface according to 3GPP TS 27.002 [34] and 3GPP TS 27.003 [35].

Example (d) of figure 3 illustrates the connection of a MT2 PCMCIA card to a TE2 by a PCMCIA 2.1 interface according to 3GPP TS 27.002 [34] and 3GPP TS 27.003 [35].

Example (f) of figure 3 illustrates the connection of a speech only MS.

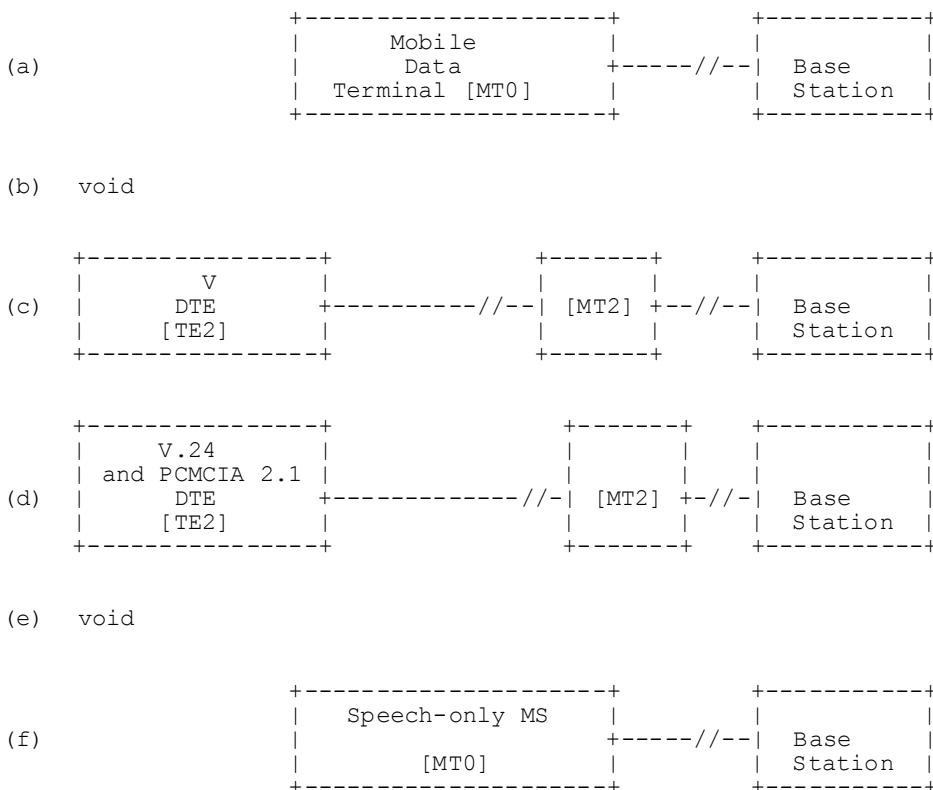

Figure 3: Examples of physical implementations

Annex A (informative): Change history

Change history							
Date	TSG #	TSG Doc.	CR	Rev	Subject/Comment	Old	New
30.3.2000	CN#7	-	-	-	Transferred to 3GPP for R99 (from GSM 04.02 v7.0.0).		3.0.0
12-2000	NP-10	NP-000673	001	2	CR 24.002 on Adaptations for UMTS	3.0.0	3.1.0
03-2001	NP-11				TSG CN#11 decided to issue RELEASE 4 of the specification 3GPP TS 24.002	3.1.0	4.0.0
06-2002	NP-16				CN#16 decided to issue this TS also for Release 5. Additionally MCC made editorial and reference updates.	4.0.0	5.0.0
03-2003	NP-19	NP-030044	003	1	Removal of the S reference point within the MS	5.0.0	5.1.0
06-2003					Corrected the coverpage and some formatting, - MCC editorial.	5.1.0	5.1.1
12-2004	NP-26				Rel-6 published after CN#26	5.1.1	6.0.0
					Upgraded to Rel-7 by MCC	6.0.0	7.0.0
					Upgraded to Rel-8 by MCC	7.0.0	8.0.0
03-2009	CP-43	CP-090243	0004	4	Inclusion of LTE in scope	8.0.0	8.1.0
03-2009	CP-43	CP-090159	0005		Removal of unused references	8.0.0	8.1.0
12-2009	CP-46				Upgraded to Rel-9 by MCC	8.1.0	9.0.0
03-2011	CP-51				Upgraded to Rel-10 by MCC	9.0.0	10.0.0
09-2012	CP-57				Upgraded to Rel-11 by MCC	10.0.0	11.0.0