

# 3GPP TR 23.910 V5.5.0 (2005-03)

---

*Technical Report*

## **3rd Generation Partnership Project; Technical Specification Group Core Network; Circuit switched data bearer services (Release 5)**



The present document has been developed within the 3<sup>rd</sup> Generation Partnership Project (3GPP<sup>TM</sup>) and may be further elaborated for the purposes of 3GPP.

The present document has not been subject to any approval process by the 3GPP Organisational Partners and shall not be implemented. This Specification is provided for future development work within 3GPP only. The Organisational Partners accept no liability for any use of this Specification. Specifications and reports for implementation of the 3GPP<sup>TM</sup> system should be obtained via the 3GPP Organisational Partners' Publications Offices.

---

Keywords

---

UMTS, circuit mode, bearer, data, network

**3GPP**

Postal address

---

3GPP support office address

---

650 Route des Lucioles - Sophia Antipolis  
Valbonne - FRANCE  
Tel.: +33 4 92 94 42 00 Fax: +33 4 93 65 47 16

Internet

---

<http://www.3gpp.org>

---

**Copyright Notification**

---

No part may be reproduced except as authorized by written permission.  
The copyright and the foregoing restriction extend to reproduction in all media.

© 2005, 3GPP Organizational Partners (ARIB, ATIS, CCSA, ETSI, TTA, TTC).  
All rights reserved.

# Contents

Foreword .....	5
1 Scope .....	6
2 References.....	6
3 Definitions and abbreviations .....	7
3.1 Definitions .....	7
3.2 Abbreviations .....	7
4 General.....	7
4.1 Limited set of UTRAN Iu mode PLMN connection models .....	8
4.1.1 Transparent data.....	8
4.1.2 Non-transparent data.....	10
4.2 Limited set of GERAN Iu mode PLMN connection models .....	10
4.2.1 Transparent data.....	10
4.2.2 Non-transparent data.....	12
5 Bearer Capabilities for UMTS Data Services .....	12
5.1 Bearer Capabilities for UMTS Data Services .....	13
5.1.1 Transparent Data .....	13
5.1.2 Non-Transparent Fax.....	13
5.1.3 NT Data.....	13
5.1.4 Transparent Data for Support of Multimedia .....	13
5.2 BC-IE to RAB QoS Mapping.....	14
5.2.1 Non-transparent services, including Fax for UTRAN Iu mode .....	14
5.2.2 Transparent Data, including Multimedia .....	15
5.2.3 Non-transparent services for GERAN Iu mode .....	16
6 Iu and Nb User Plane.....	18
6.1 NT services .....	18
6.2 T services .....	18
6.2.1 Avoidance of delay at RNC.....	19
6.2.2 Recovery from the loss of ATM cells.....	19
7 RLC.....	19
8 Initial Synchronisation and resynchronisation .....	19
8.1 Modem services (3.1 kHz audio) .....	19
8.1.1 Transparent Case.....	19
8.1.2 Non-Transparent Case.....	20
8.2 Digital services.....	20
8.2.1 Transparent case.....	20
8.2.2 Non-Transparent case.....	20
8.3 Loss of synchronisation.....	20
9 Call Control.....	20
10 Handover Issues.....	20
10.1 Signalling issues .....	20
10.1.1 Loss of BC Information during Handover from A/Gb mode to UTRAN Iu mode .....	20
10.1.2 Handover from UTRAN Iu mode to A/Gb mode .....	21
10.1.3 Loss of BC Information during Handover from A/Gb mode to GERAN Iu mode .....	21
10.1.4 Handover from GERAN Iu mode to A/Gb mode .....	21
10.1.5 Handover from UTRAN Iu mode to GERAN Iu mode .....	21
10.1.6 Handover from GERAN Iu mode to UTRAN Iu mode .....	21
10.2 User Plane .....	22
10.2.1 Handover from Iu mode to A/Gb mode .....	22
10.2.2 Handover from A/Gb mode to UTRAN Iu mode .....	22
10.2.2.1 Frame layout for the different transparent user rates .....	22
10.2.2.2 A-TRAU' frame format .....	23

10.2.3 Handover from A/Gb mode to GERAN Iu mode .....25

10.2.3.1 User plane for transparent services .....25

10.2.3.2 User plane for non-transparent services.....25

10.2.3.2.1 A-TRAU" frame format ..... 25

10.2.4 Handover within Iu mode PLMNs ..... 28

10.2.5 Handover for 56 kbit/s..... 28

**Annex A: Change history.....29**

---

# Foreword

This Technical Report (TR) has been produced by the 3<sup>rd</sup> Generation Partnership Project (3GPP).

The contents of the present document are subject to continuing work within the TSG and may change following formal TSG approval. Should the TSG modify the contents of the present document, it will be re-released by the TSG with an identifying change of release date and an increase in version number as follows:

Version x.y.z

where:

- x the first digit:
  - 1 presented to TSG for information;
  - 2 presented to TSG for approval;
  - 3 or greater indicates TSG approved document under change control.
- y the second digit is incremented for all changes of substance, i.e. technical enhancements, corrections, updates, etc.
- z the third digit is incremented when editorial only changes have been incorporated in the document.

---

# 1 Scope

The present document provides an overview of the architecture and issues related to the provision of Circuit Switched Bearer Services in a 3G mobile network (UMTS) operating in UTRAN or GERAN Iu mode. Handover to GERAN A/Gb mode is also considered.

NOTE: The Gb interface does not play any role in the scope of the present document although the term "A/Gb mode" is used.

---

# 2 References

The following documents contain provisions which, through reference in this text, constitute provisions of the present document.

- References are either specific (identified by date of publication, edition number, version number, etc.) or non-specific.
- For a specific reference, subsequent revisions do not apply.
- For a non-specific reference, the latest version applies. In the case of a reference to a 3GPP document (including a GSM document), a non-specific reference implicitly refers to the latest version of that document in the same Release as the present document.

- [1] 3GPP TS 43.010: "GSM Public Land Mobile Network (PLMN) connection types".
- [2] 3GPP TR 21.905: "Vocabulary for 3GPP Specifications".
- [3] 3GPP TS 22.100: "UMTS phase 1".
- [4] 3GPP TS 22.002: "Circuit Bearer Services (BS) supported by a Public Land Mobile Network (PLMN)".
- [5] 3GPP TS 22.101: "Service principles".
- [6] 3GPP TS 22.105: "Services and service capabilities".
- [7] 3GPP TS 23.002: "Network architecture".
- [8] 3GPP TS 23.034: "High Speed Circuit Switched Data (HSCSD) -Stage 2".
- [9] 3GPP TS 23.101: "General UMTS architecture".
- [10] 3GPP TS 23.107: "Quality of Service (QoS), concept and architecture".
- [11] 3GPP TS 24.022: "Radio Link Protocol (RLP) for circuit switched bearer and teleservices".
- [12] 3GPP TS 25.322: "Radio Link Control (RLC) protocol specification".
- [13] 3GPP TS 25.415: "UTRAN Iu Interface user plane protocols".
- [14] 3GPP TS 27.001: "General on Terminal Adaption Functions (TAF) for Mobile Station (MS)".
- [15] 3GPP TS 29.007: "General requirements on interworking between the Public Land Mobile Network (PLMN) and the Integrated Services Digital Network (ISDN) or Public Switched Telephone Network (PSTN)".
- [16] ITU-T Recommendation V.90: "A digital modem and analogue modem pair for use on the Public Switched Telephone Network (PSTN) at data signalling rates of up to 56 000 bit/s downstream and up to 33 600 bit/s upstream".
- [17] ITU-T Recommendation T.30 "Procedures for document facsimile transmission in the general switched telephone network".
- [18] 3GPP TS 44.021: "Rate adaption on the Mobile Station - Base Station System (MS - BSS) interface".

- [19] 3GPP TS 48.020: " Rate adaption on the Base Station System - Mobile-services Switching Centre (BSS - MSC) interface".
- [20] ITU-T Recommendation I.366.1: "Segmentation and Reassembly Service Specific Convergence Sublayer for the AAL type 2".
- [21] ITU-T Recommendation Q.2630.1: "AAL type 2 signalling protocol (Capability Set 1)".
- [22] 3GPP TS 43.051: "GSM/EDGE Radio Access Network (GERAN) overall description, stage 2"
- [23] 3GPP TS 43.010: "GSM Public Land Mobile Network (PLMN) connection types"
- [24] 3GPP TS 29.415: "Customized Applications for Mobile network Enhanced Logic (CAMEL) Phase 3; CAMEL Application Part (CAP) specification".
- [25] ITU-T Recommendation I.363.2: "B-ISDN ATM Adaptation Layer specification : Type 2 AAL".
- [26] ITU-T Recommendation I.460: "Multiplexing, rate adaption and support of existing interfaces".
- [27] ITU-T Recommendation I.366.2: "AAL type 2 service specific convergence sublayer for narrow-band services".

---

## 3 Definitions and abbreviations

### 3.1 Definitions

The term 'Mobile Station' (MS) in the present document is synonymous with the term 'User Equipment' (UE) as defined in 3GPP TR 21.905 [2].

For the purposes of the present document the following terms and definitions given in 3GPP TS 21.905 [2] and the following apply:

**A/Gb mode:** indicates that the text applies only to a system or sub-system which operate in A/Gb mode of operation, i.e. with a functional division that is in accordance with the use of an A or a Gb interface between the radio access network and the core network

**Iu mode:** indicates that the text applies only to a system or a sub-system which operates in Iu mode of operation, i.e. with a functional division that is in accordance with the use of an Iu-CS or Iu-PS interface between the radio access network and the core network

### 3.2 Abbreviations

For the purposes of the present document, the abbreviations given in 3GPP TS 21.905 [2] and the following apply.

BC	Bearer Capability
CE	Connection Element
CT	Circuit
GBR	Guaranteed Bitrate
MBR	Maximum Bitrate
RA	Rate Adaptation Functions
RNL	Radio Network Layer
S/C	Split/Combine Function
WAIUR	Wanted Air Interface User Rate

---

## 4 General

CS data services in UMTS are build on services provided by the Access Network. These Radio Access Bearer Services are invoked through the RNL-SAP provided by the Iu User Plane to the Non-access stratum on the Core Network side, and the corresponding SAP provided by the RLC to the Non-access stratum on the Terminal side. Transport within the

CN (the CN Bearer services) is outside the scope of the present document. Interworking with External Bearer services is within the scope of the present document. (see figure 1).

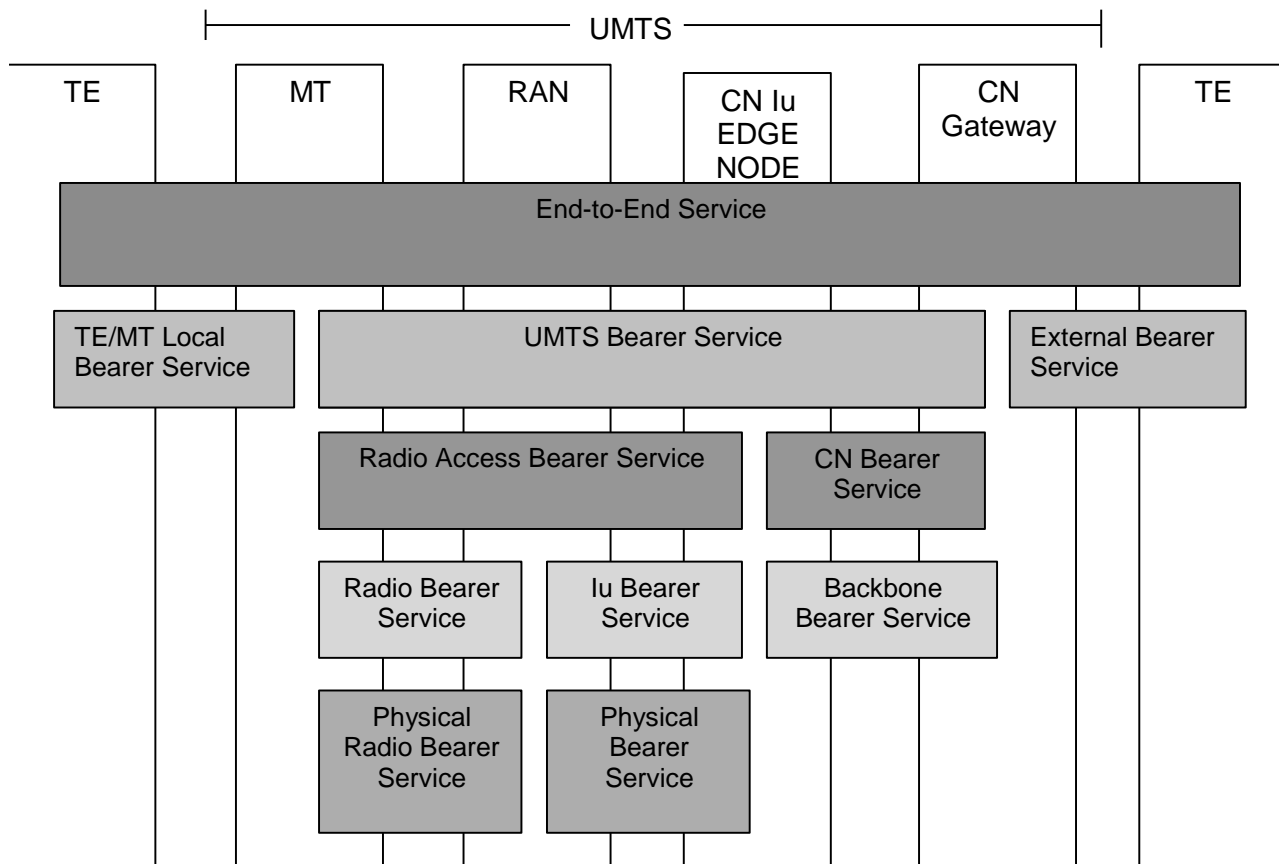

Figure 1: Service architecture

## 4.1 Limited set of UTRAN Iu mode PLMN connection models

### 4.1.1 Transparent data

Figure 2 shows the connection model for synchronous transparent CS data. In general all the user data bits are conveyed between the MT and the IWF as they are received from the TE. This implies that the RLC SDU/ Iu UP frame is transparent.

Figure 3 shows the connection model for asynchronous transparent CS data. The rate adaptation function RA0 from 3GPP TS 44.021 [18] (adapted to the RLC SDU size) is used for converting between asynchronous data and a synchronous bit stream. End-to-end flow control is not applicable in UTRAN Iu mode, thus no status bits are conveyed over RAN/UTRAN (see 3GPP TS 27.001 [14]).



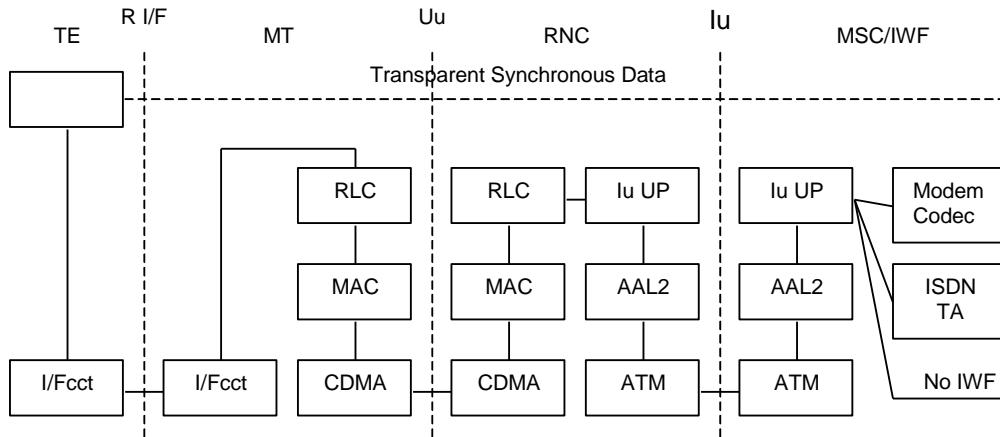

Figure 2: Connection model for Synchronous T CS data

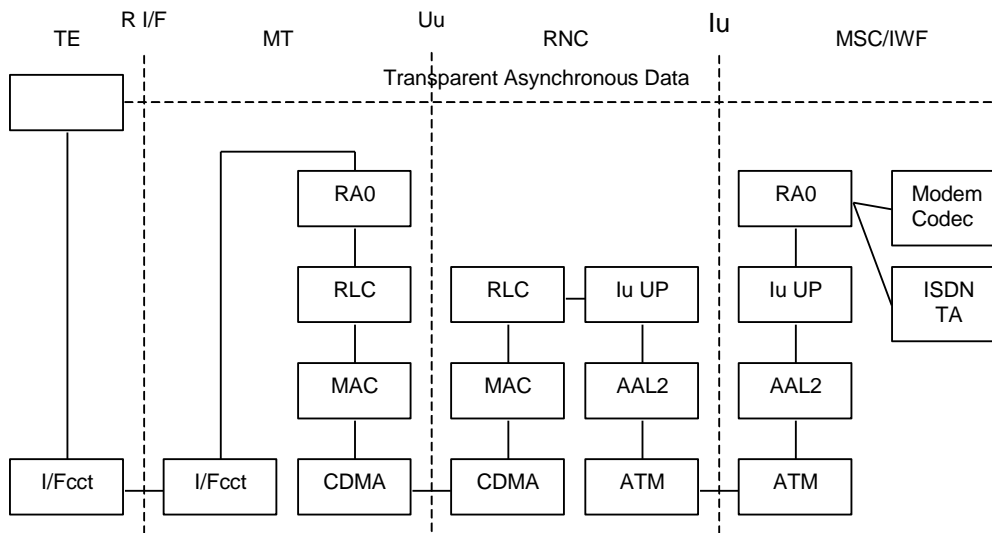

Figure 3: Connection model for Asynchronous T CS data

## 4.1.2 Non-transparent data

Figure 4 shows the connection model for asynchronous non-transparent CS data.

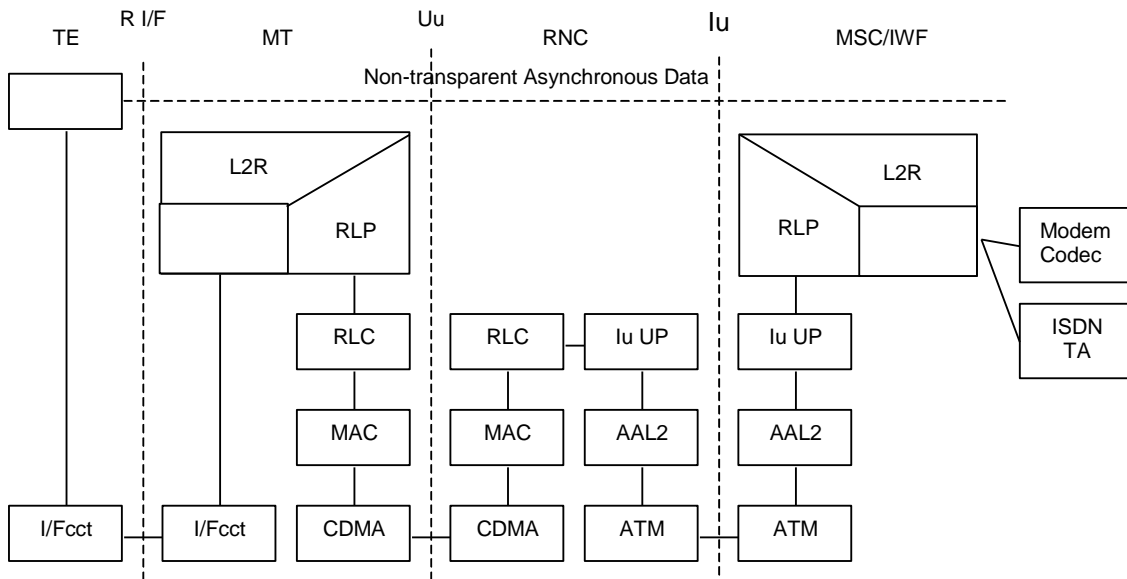

Figure 4: Connection model for Asynchronous NT CS data

## 4.2 Limited set of GERAN Iu mode PLMN connection models

This subclause gives an overall overview on the PLMN connection models for circuit switched data services in GERAN Iu mode. The stage 2 description is given in 3GPP TS 43.051 [22]. For details concerning the PLMN connection models refer to 3GPP TS 43.010 [23].

### 4.2.1 Transparent data

Figure 5 shows the connection model for synchronous transparent CS data. In general all the user data bits are conveyed between the MT and the IWF as they are received from the TE. This implies that the RLC SDU/ Iu UP frame is transparent.

Figure 6 shows the connection model for asynchronous transparent CS data. The rate adaptation function RA0 from 3GPP TS 44.021 [18] (adapted to the RLC SDU size) is used for converting between asynchronous data and a synchronous bit stream. End-to-end flow control is not applicable in GERAN Iu mode, thus no status bits are conveyed over RAN/GERAN (see 3GPP TS 27.001 [14]).

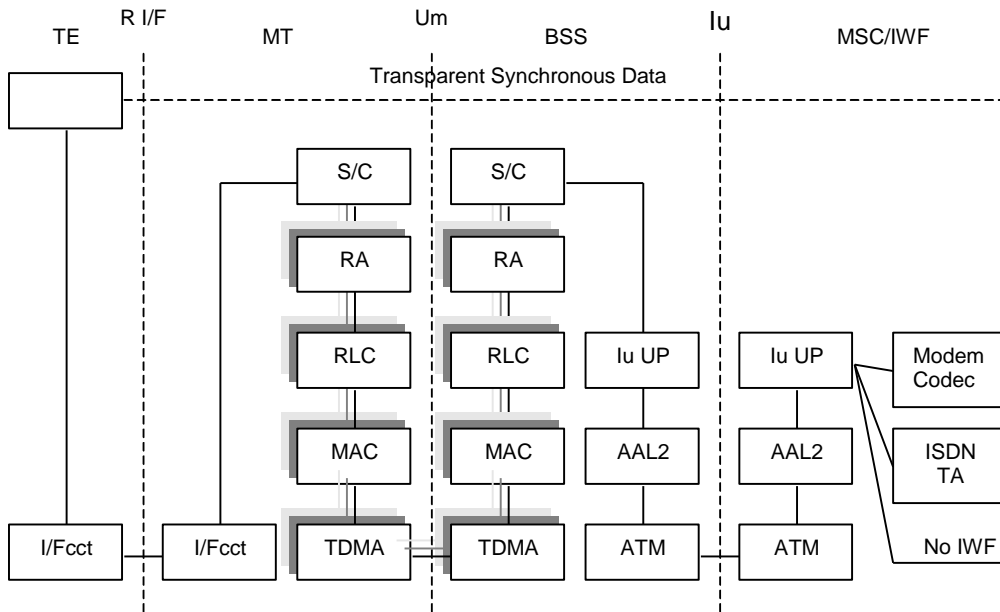

Figure 5: Connection model for Synchronous T CS data

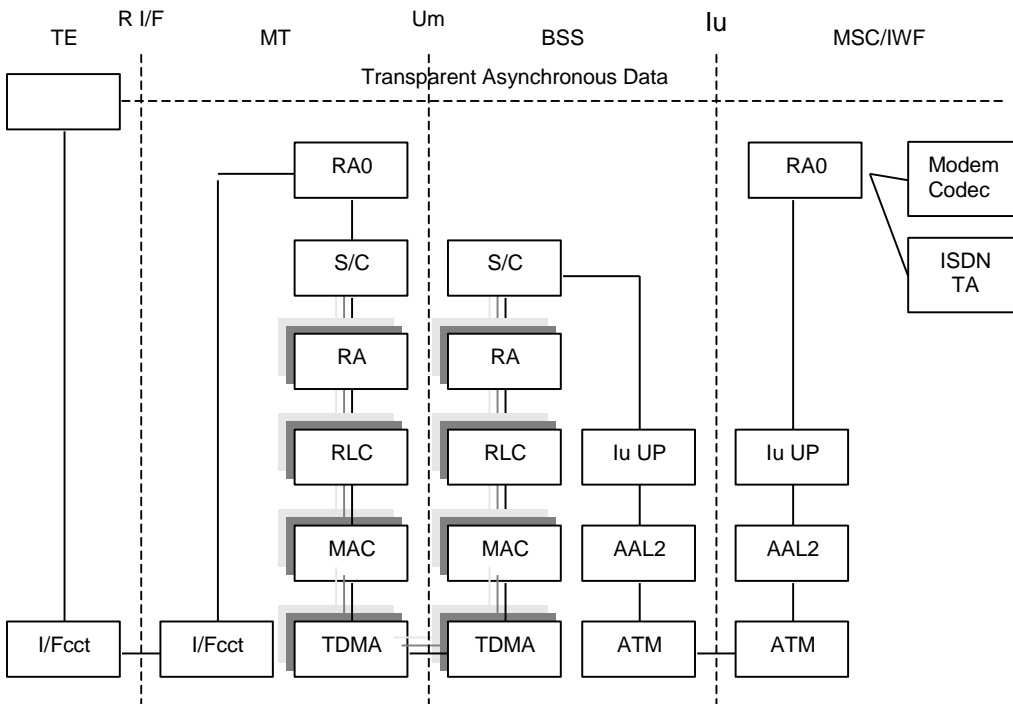

Figure 6: Connection model for Asynchronous T CS data

## 4.2.2 Non-transparent data

Figure 7 shows the connection model for asynchronous non-transparent CS data.

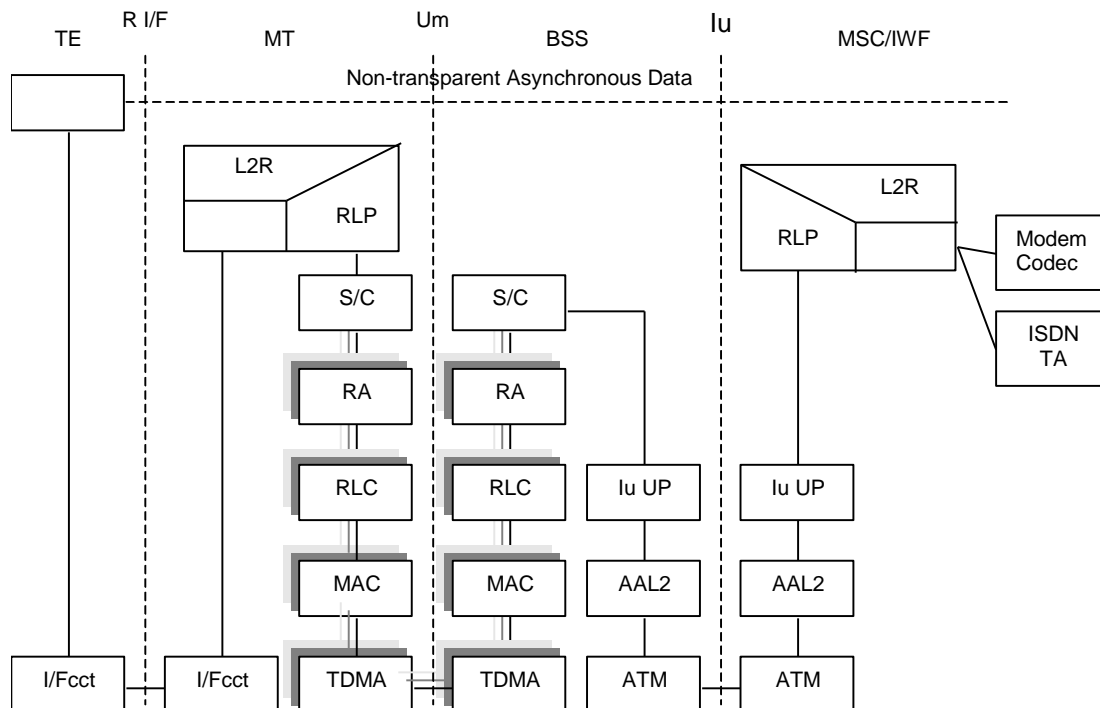

Figure 7: Connection model for Asynchronous NT CS data

## 5 Bearer Capabilities for UMTS Data Services

The UMTS bearer services are described by the PLMN BC-IE. Five services (or services categories) are currently distinguishable from the PLMN BC-IE in UTRAN Iu mode:

- Speech.
- Transparent Data for support of Multimedia.
- Transparent Data.
- Non-transparent Fax.
- Non-transparent data.

Four services (or services categories) are currently distinguishable from the PLMN BC-IE in GERAN Iu mode:

- Speech.
- Transparent Data for support of Multimedia.
- Transparent Data.
- Non-transparent data.

Speech is currently not in the scope of the present document.

Each UMTS bearer service is supported by a Radio Access Bearers (RAB). The RABs in turn are described by the QoS parameters. There may be one or several RAB candidates for supporting a UMTS bearer service. The possible candidates are described by a mapping of the BC-IE to RAB QoS described in subclause 5.2.

## 5.1 Bearer Capabilities for UMTS Data Services

### 5.1.1 Transparent Data

This service is distinguished by the following BC-IE parameters:

- ITC = UDI or 3.1 kHz audio or Other ITC = RDI.
- CE = transparent.

For this service the FNUR at the setup is restricted to:

- 64 kbit/s, in case ITC = UDI.
- 56 kbit/s in case ITC = UDI or Other ITC = RDI.
- 28,8 kbit/s, in case ITC = 3,1 kHz audio.

NOTE: ITU-T Recommendation V.90 [16] is not supported in transparent mode, because asymmetric user rates are not supported in transparent mode.

### 5.1.2 Non-Transparent Fax

This service is only applicable for UTRAN Iu mode. It is distinguished by the following BC-IE parameters:

- ITC = Fax Group 3 (ITU-T Recommendation T.30 [17]).
- CE = non-transparent.

WAIUR shall not be more than 28.8 kbit/s. The possible AIURs are limited to 14,4 kbit/s and 28,8 kbit/s.

### 5.1.3 NT Data

This service is distinguished by the following BC-IE parameters:

- ITC = UDI or 3.1 kHz audio or Other ITC = RDI.
- CE = non-transparent.

The possible AIURs in UTRAN Iu mode are limited to 14,4 kbit/s, 28,8 kbit/s and 57,6 kbit/s. For GERAN Iu mode the following AIURs are possible: 9,6 kbit/s, 14,4 kbit/s, 19,2 kbit/s, 28,8 kbit/s, 38,4 kbit/s, 43,2 kbit/s and 57,6 kbit/s.

### 5.1.4 Transparent Data for Support of Multimedia

This service is distinguished by the following BC-IE parameters:

- ITC = UDI or 3.1 kHz audio or Other ITC = RDI.
- CE = transparent.
- Other rate adaptation = H.223 and H.245.

For this service the FNUR at the setup is restricted to:

- 64 kbit/s, in case ITC = UDI.
- 56 kbit/s in case Other ITC = RDI.
- 33,6 kbit/s, in case ITC = 3,1 kHz audio.
- 32 kbit/s, in case ITC = UDI.
- 28,8 kbit/s, in case ITC = 3,1 kHz audio.

NOTE: Transmission rates 31.2 kbit/s and 28.8 kbit/s negotiated by the modems in a 3.1 kHz multimedia call may be used with a rate adaptation to 33.6 kbit/s between the UE and the IWF (see 3GPP TS 27.001 [14] and 3GPP TS 29.007 [15]). The negotiated values shall be provided by the MSC by way of a MODIFY message.

## 5.2 BC-IE to RAB QoS Mapping

Since UMTS bearer services are described by BC-IEs and RABs by QoS parameters, this subclause provides implicitly a mapping between the UMTS bearer services and the possible RABs that support them. The QoS mapping is based on 3GPP TS 23.107 [10].

### 5.2.1 Non-transparent services, including Fax for UTRAN Iu mode

Service identified by the BC IE	Non-transparent data	Comments
Traffic Class	Streaming	Subject to operator tuning
RAB Asymmetry Indicator	Symmetric	
Maximum bit rate (1)	14,4 kbit/s, 28,8 kbit/s, 57.6 kbit/s	Maximum bit rate is set to the highest value $\leq$ WAIUR (Note 1)
Guaranteed bit rate	14,4 kbit/s, 28,8 kbit/s, 57.6 kbit/s	Operator may choose any of the possible values less or equal to WAIUR. (Note 1)
Delivery Order	Yes	
Maximum SDU size	576 bits	
Transfer Delay	250 ms	Subject to operator tuning
Traffic Handling Priority	-	Not applicable to the streaming traffic class
Source statistics descriptor	Unknown	
SDU Parameters		
Residual bit error ratio	$10^{-3}$	Subject to operator tuning.
Delivery of erroneous SDUs	No error detection consideration	
SDU format information		
RAB Subflow Combination bit rate	57,6 kbit/s	(Note 2)
RAB Subflow Combination bit rate	28,8 kbit/s	(Note 2)
RAB Subflow Combination bit rate	14,4 kbit/s	
RAB Subflow Combination bit rate	0 kbit/s	indicates DTX, RFCI is not assigned
NOTE 1: If WAIUR is less or equal to 14.4 kbit/s then GBR and MBR shall be set to 14.4 kbit/s.		
NOTE 2: Only RAB subflow combination bit rates $\leq$ maximum bit rate shall be specified.		

## 5.2.2 Transparent Data, including Multimedia

Service identified by the BC IE	Transparent data and BS for support of multimedia service	Comments
Traffic Class	Conversational	Subject to operator tuning
Maximum bit rate	= guaranteed bit rate	
Guaranteed bit rate	FNUR = 64 .. 28.8 kbit/s (Note 2)	GBR for FNUR=56 kbit/s is 64 kbit/s (Note 1)
Delivery Order	Yes	
Maximum SDU size	640 bits for FNUR=32, 56 and 64 kbit/s 576 bits for FNUR=28.8 kbit/s 672 bits for FNUR=33.6 kbit/s	
Transfer Delay	< 200 ms	Subject to operator tuning
Traffic Handling Priority	-	Not applicable for the conversational traffic class
Source statistics descriptor	Unknown	
SDU Parameters		
SDU error ratio	-	Not applicable
Residual bit error ratio	$10^{-4}$	Subject to operator tuning according to 3GPP TS 23.107. Operator may also choose different value for Multimedia and other transparent data services.
Delivery of erroneous SDUs	-	No error detection in the core network

NOTE 1: In case the FNUR = 56 kbit/s, the GBR is set to 64 kbit/s. Last bit in each data octet is set to 1.

NOTE 2: If the FNUR is changed as a result of a MODIFY procedure during the call, the guaranteed bit rate is not changed.

### 5.2.3 Non-transparent services for GERAN Iu mode

Service identified by the BC IE	Non-transparent data	Comments
Traffic Class	Streaming	Subject to operator tuning
RAB Asymmetry Indicator	Symmetric	
Maximum bit rate	12 kbit/s, 14,4 kbit/s, 24 kbit/s, 28,8 kbit/s, 36 kbit/s, 43,2 kbit/s, 48 kbit/s, 57.6 kbit/s	Maximum bit rate is set to the highest value $\leq$ WAIUR (Notes 1, 3, 4, 5 and 6)
Guaranteed bit rate	12 kbit/s, 14,4 kbit/s, 24 kbit/s, 28,8 kbit/s, 36 kbit/s, 43,2 kbit/s, 48 kbit/s, 57.6 kbit/s	Operator may choose any of the possible values less or equal to WAIUR. (Note 1)
Delivery Order	Yes	
Maximum SDU size	480 bits if only RAB Subflow Combination bit rates of multiples of 12 kbit/s are possible, 576 bits in all other cases	
Transfer Delay	230 ms if only RAB Subflow Combination bit rates of multiples of 12 kbit/s are possible, 250 ms in all other cases	Subject to operator tuning
Traffic Handling Priority	-	Not applicable to the streaming traffic class
Source statistics descriptor	Unknown	
SDU Parameters		
Residual bit error ratio	$10^{-3}$	Subject to operator tuning.
Delivery of erroneous SDUs	No error detection consideration	
SDU format information		
	Subflow SDU size	576 bit (Note 7)
	RAB Subflow Combination bit rate	57,6 kbit/s (Note 2)
	Subflow SDU size	480 bit (Note 7)
	RAB Subflow Combination bit rate	48 kbit/s (Notes 2 and 3)
	Subflow SDU size	576 bit (Note 7)
	RAB Subflow Combination bit rate	43,2 kbit/s (Note 2)
	Subflow SDU size	480 bit (Note 7)
	RAB Subflow Combination bit rate	36 kbit/s (Notes 2 and 4)
	Subflow SDU size	576 bit (Note 7)
	RAB Subflow Combination bit rate	28,8 kbit/s (Note 2)
	Subflow SDU size	480 bit (Note 7)
	RAB Subflow Combination bit rate	24 kbit/s (Notes 2 and 5)
	Subflow SDU size	576 bit (Note 7)
	RAB Subflow Combination bit rate	14,4 kbit/s (Note 2)
	Subflow SDU size	480 bit (Note 7)
	RAB Subflow Combination bit rate	12 kbit/s (Notes 2 and 6)
	RAB Subflow Combination bit rate	0 kbit/s indicates DTX, RFCI is not assigned
NOTE 1: If WAIUR is less or equal to 14.4 kbit/s then GBR and MBR shall be set to 14.4 kbit/s for TCH/F14.4. If WAIUR is less or equal to 9.6 kbit/s then GBR and MBR shall be set to 12 kbit/s for TCH/F9.6. The maximum values for GBR and MBR shall not exceed the WAIUR unless the higher GBR and MBR can be reached with a smaller number of TCH/F (see 3GPP TS 27.001 [14], subclause B.1.12.2). This means, that e.g., a GBR and MBR of 24 kbit/s (2 x TCH/F9.6) can be selected for a WAIUR of 19,2 kbit/s.		
NOTE 2: Only RAB subflow combination bit rates $\leq$ maximum bit rate shall be specified.		
NOTE 3: If the WAIUR is 38,4 kbit/s, a GBR and MBR of 48 kbit/s is possible for 4 x TCH/F9.6.		
NOTE 4: If the WAIUR is 28,8 kbit/s, a GBR and MBR of 36 kbit/s is possible for 3 x TCH/F9.6.		
NOTE 5: If the WAIUR is 19,2 kbit/s, a GBR and MBR of 24 kbit/s is possible for 2 x TCH/F9.6.		
NOTE 6: If the WAIUR is 9,6 kbit/s, a GBR and MBR of 12 kbit/s is possible for 1 x TCH/F9.6.		
NOTE 7: The Subflow SDU size should only be present when the individual Subflows have different sizes.		





## 6 Iu and Nb User Plane

### 6.1 NT services

On the Iu interface and if TDM is not used on the Nb interfaces between the access network and the IWF, this paragraph is applicable, except for the Nb interface in the case of inter-MSC relocation. The Iu and Nb user planes are used in support mode, see 3GPP TS 25.415 [13] and 3GPP TS 29.415 [24]. Each SDU corresponds to one RLP frame and, consequently, is 576 bits long. In GERAN Iu mode another SDU size of 480 bits is possible. It carries two RLP frames of 240 bits and is used if TCH/F9.6 is used in GERAN. Each SDU is transported in one Iu or Nb UP PDU of Type 1. In UTRAN Iu mode, the range of RAB Subflow Combination bit rate values is 14,4 kbit/s, 28,8 kbit/s, 57,6 kbit/s, limited by the maximum bit rate, and varies with the transmission period on the Uu interface, which is 40 ms, 20 ms or 10 ms. In GERAN Iu mode these values are valid if TCH/F14.4, TCH/28.8 or TCH/F43.2 is used. In addition GERAN Iu mode has a RAB Subflow Combination bit rate of 43,2 kbit/s with a transmission period of 13½ ms. If TCH/F9.6 is used, the range of RAB Subflow Combination bit rate values is 12 kbit/s, 24 kbit/s, 36 kbit/s, 48 kbit/s, limited by the maximum bit rate, and varies with the transmission period on the Um interface, which is 40 ms, 20 ms, 13½ ms or 10 ms. A change in the transmission period is signalled to the IWF through the Iu and Nb UP protocols. The Iu or Nb UP primitive Iu- or Nb-UP-DATA-REQUEST is invoked each time an RLP frame is ready to be sent from the IWF towards the UE. DTX indication is not used.

The following table shows the connection between the RAB subflow combination bit rate and the AIUR.

RAB subflow combination bit rate	AIUR	Used number of traffic channels and channel coding for GERAN Iu mode	Comment
57,6 kbit/s	57,6 kbit/s	4xTCH/F14.4, 2xTCH/F28.2	(Note 1)
43,2 kbit/s	43,2 kbit/s	3xTCH/F14.4, 1xTCH/F43.2	(Note 2)
48 kbit/s	38,4 kbit/s	4xTCH/F9.6	(Note 2)
36 kbit/s	28,8 kbit/s	3xTCH/F9.6	(Note 2)
28,8 kbit/s	28,8 kbit/s	2xTCH/F14.4, 1xTCH/F28.2	(Note 1)
24 kbit/s	19,2 kbit/s	2xTCH/F9.6	(Note 2)
14,4 kbit/s	14,4 kbit/s	1xTCH/F14.4	(Note 1)
12 kbit/s	9,6 kbit/s	1xTCH/F9.6	(Note 2)
NOTE 1: RAB subflow combination bit rate is used in UTRAN Iu mode and GERAN Iu mode			
NOTE 2: RAB subflow combination bit rate is only used in GERAN Iu mode			

For Inter-MSC relocation this paragraph is applicable for the Nb interface between the access network and the IWF. The Nb UP protocol is applied in support mode and the SDU size is 320 bits, transmitted every 5 ms. PDU type 0 is used. The data within the PDU is encoded as A-TRAU' frames.

If TDM is not used, then between the IWF and the fixed network (ISDN or PSTN), the Nb UP protocol is applied in support mode and the SDU size is 320 bits, transmitted every 5 ms. PDU type 0 is used.

### 6.2 T services

On the Iu interface, the Iu UP is used in transparent mode, see 3GPP TS 25.415 [13]. The payload of the Iu and Nb frames will consist of user data bits only for synchronous data, and RA0 synchronous bit streams for asynchronous data.

On the Iu interfaces, the payload (SDU) size is fixed, determined by the bit rate. Following table shows SDU sizes. AAL2 is used. The AAL2 SSCS layer shall be supported for segmentation and re-assembly.

Bit rate	SDU size (= RLC PDU payload size)
28.8 kbit/s	576 bits
33.6 kbit/s	672 bits
32 kbit/s	640 bits
56/64 kbit/s	640 bits

The primitive Iu-UP \_UNIT-DATA-REQUEST is invoked at regular intervals in order to have a constant bit rate (every SDU).

If TDM is not used at the Nb interface, then the Nb UP protocol is applied in support mode and the SDU size is 320 bits, transmitted every 5 ms. PDU type 0 is used.

## 6.2.1 Avoidance of delay at RNC

The TTI-to-CPS Packet packaging delay can be avoided by choosing the length of the CPS packet payload so that the payloads of an integer number of CPS Packets fill one TTI. The contents of the whole TTI can be sent further towards the MSC immediately after the reception without waiting for the next TTI.

## 6.2.2 Recovery from the loss of ATM cells

The ATM cell loss rate is estimated to be very small (less than  $10^{-6}$  ...  $10^{-8}$ ), the quality of transmission being comparable to that of a high quality ISDN.

The following happens if a cell is lost (see ITU-T Recommendation I.363.2 [25]):

- At least one CPS packet is distorted.
- The distorted CPS packet(s) is/are discarded by the receiver.
- If only one CPS packet is discarded, the upper layer can identify the event by the UUI/SSSAR sequence number, and consequently insert a fill sequence of the length of a CPS payload field to the correct place in the bit stream. ITU-T Recommendation I.366.1[20] (SSSAR) describes that UUI takes value between 0 and 26 for final data and value 27 for more data, but UUI should take value 26 for final data considering compatibility with other SSSAR specifications. When UUI works as sequence number by repetition of 27 and 26, CPS packet payload size is equal to half a SDU size. This CPS packet payload size also satisfies the requirement described in subclause 6.2.1. CPS packet payload size is set by ITU-T Recommendation Q.2630.1 [21] over Iu interface.
- If more than one CPS packets are discarded, the upper layer can identify the event by monitoring the buffer level at the ATM/TDM interface or by monitoring the reception of CPS packets with a timer. (The modulo 2 sequence number cannot indicate the loss of two consecutive CPS packets). The following figures apply for the 40 octet payload field.
- Worst case: 2 packets lost  $\Rightarrow 2 \times 40$  octets  $\times 8$  bits/octet : 64 kbit/s = 10 ms, i.e. buffer level decreased by 80 octets.
- Consequently, recovery with fill inserted in the correct place is possible, if the ATM cell jitter (i.e. transmission delay variation) is less than 5 ms. With a bigger jitter fill may be inserted in a wrong place in the TDM bit stream.

---

# 7 RLC

The RLC shall be used in transparent mode for T and NT services.

---

# 8 Initial Synchronisation and resynchronisation

## 8.1 Modem services (3.1 kHz audio)

### 8.1.1 Transparent Case

The IWF does not send any SDUs down link until the modem connection has been established and the modems have synchronised. Thereafter the IWF through connects, mapping data from the fixed network side onto SDUs that are sent toward the MS, and mapping data in the received SDUs to the fixed network side.

The MS sends no SDUs until an SDU is received at the transmission SAP. Until the first access stratum SDU is received, CT 106, 107 and 109 remain in the OFF condition. At the reception of the first SDU, CT 106, CT 107 and

CT 109 are changed from OFF to ON at the DCE/DTE (TE/TAF) interface. The data in the received SDUs are mapped to CT 104 and data on CT 103 are mapped to SDUs sent toward the RNC.

### 8.1.2 Non-Transparent Case

At the IWF, the synchronisation of modems on the transit network is performed after establishment of the physical connection. The RLP establishment may be initiated by the IWF, but is normally initiated by the MS. If the modems synchronise before the RLP has been established, the IWF stores the information received from the other modem in the L2R buffers.

The UE initiates the RLP after the physical connection has been established. When the RLP link has been established, CT107 at the DCE/DTE interface will be changed from "OFF" to "ON". From this time the information from/to the RLP, including status changes, will be mapped by the L2R entity.

## 8.2 Digital services

### 8.2.1 Transparent case

The procedures are the same as for the modem case, but, depending on implementation, the IWF may through connect before the fixed network leg has been synchronised.

### 8.2.2 Non-Transparent case

The procedures are the same as for the modem case.

## 8.3 Loss of synchronisation

The PLMN side is not synchronous so loss of synchronisation is not possible. For T services, SDUs may be lost or arrive irregularly, which handling is implementation dependent.

Loss of synchronisation on the fixed network side is handled as in A/Gb mode.

---

# 9 Call Control

BC-IE negotiation procedures and mapping to ISDN are specified in 3GPP TS 27.001 [14] and 3GPP TS 29.007 [15]. BC-IE parameter values shall be restricted as indicated in subclause 5.1. See also 3GPP TS 27.001 [14], annex B, table B.5a for further details on the validity of parameter values in A/Gb mode and Iu mode.

---

## 10 Handover Issues

### 10.1 Signalling issues

#### 10.1.1 Loss of BC Information during Handover from A/Gb mode to UTRAN Iu mode

In the case of inter-MSC handover from A/Gb mode to UTRAN Iu mode, the serving A/Gb mode MSC/VLR sends a MAP message Prepare Handover carrying the BSSMAP message Handover Request. This message includes the parameter Channel Type, indicating whether radio resources are to be allocated for speech or data (parameter 'Speech or data indicator') and, among other data, the type of data service (transparent/non transparent) and the user rates (both included in the parameter 'Data rate and transparency indicator').

As no other bearer capability related parameters are received, it is not possible to distinguish between any other services than 'speech', 'data transparent' and 'data non-transparent'.

The mapping into QoS radio access parameters would be done as described in subclause 5.2, limited to the services 'speech', 'data, non-transparent' and 'data, transparent'.

### 10.1.2 Handover from UTRAN Iu mode to A/Gb mode

In case a UTRAN Iu mode call is set up in the CN, the BC IE parameters are mapped into QoS RAB parameters at call setup.

If the CN has to perform a handover towards A/Gb mode, the non-anchor MSC needs to perform an assignment based on GSM traffic channel parameters.

In case of handover from UTRAN Iu mode to A/Gb mode, the anchor MSC maps the BC IE parameters into A/Gb mode traffic channel parameters. This requires that the BC IE is coded according to A/Gb mode protocol requirements, i.e. all those parameters ignored in UTRAN Iu mode should nevertheless be correctly specified by the UE in order to perform a handover to A/Gb mode.

### 10.1.3 Loss of BC Information during Handover from A/Gb mode to GERAN Iu mode

Subclause 10.1.1 applies also to handover from A/Gb mode to GERAN Iu mode.

Additionally, the serving A/Gb mode MSC/VLR will include the parameter GERAN Classmark in the MAP message Prepare Handover, if this parameter is available. The GERAN Classmark, which indicates the capabilities of the BSS in the target cell (e.g. allowed channel codings and maximum number of traffic channels), shall be taken into account by the target MSC when it performs the mapping into QoS radio access parameters.

### 10.1.4 Handover from GERAN Iu mode to A/Gb mode

Subclause 10.1.2 applies also to handover from GERAN Iu mode to A/Gb mode.

**NOTE:** The protocol requirements for the coding of the BC IE according to GERAN Iu mode are the same as for A/Gb mode, i.e. all those parameters needed in order to perform a handover to A/Gb mode are available.

### 10.1.5 Handover from UTRAN Iu mode to GERAN Iu mode

The serving UTRAN Iu mode MSC/VLR will send a MAP message Prepare Handover carrying the RANAP message Relocation Request. When setting the QoS RAB parameters in the RANAP message Relocation Request, the serving UTRAN Iu mode MSC/VLR shall take into account:

- the GERAN Classmark of the target cell, if this parameter is available;
- the allowed channel codings and the maximum number of traffic channels from the BC IE, if the serving MSC is the anchor MSC; and
- the allowed radio interface rates (included in the parameter Channel Type), if the serving MSC is not the anchor MSC.

This requires that the BC IE is coded according to GERAN Iu mode protocol requirements, i.e. all those parameters ignored in UTRAN Iu mode should nevertheless be correctly specified by the UE in order to perform a handover to GERAN Iu mode. Furthermore, it requires that the anchor MSC maps the BC IE parameters into A/Gb mode traffic channel parameters and includes the parameter Channel Type in the MAP message Prepare Handover also for basic handover to UTRAN Iu mode.

### 10.1.6 Handover from GERAN Iu mode to UTRAN Iu mode

The serving GERAN Iu mode MSC/VLR will send a MAP message Prepare Handover carrying the RANAP message Relocation Request. When setting the QoS RAB parameters in the RANAP message Relocation Request, the serving GERAN Iu mode MSC/VLR shall take the mode of the target cell into account. (See subclause 5.2. For non-transparent services, some of the RAB Subflow Combination bit rates are supported in GERAN Iu mode, but not in UTRAN Iu mode.)

## 10.2 User Plane

### 10.2.1 Handover from Iu mode to A/Gb mode

After a handover from Iu mode to A/Gb mode the user plane between the anchor MSC and the visited MSC shall comply to:

- the standard A/Gb mode A-interface protocols, i.e.:
  - A-TRAU or modified V.110 frames as defined in 3GPP TS 44.021 [18] and 3GPP TS 48.020 [19].
  - Up to four 16kbit/s substreams are multiplexed in one 64kbit/s channel (Split/Combine function and Multiplexing function as defined in 3GPP TS 44.021 [18] and 3GPP TS 48.020 [19]).
- the Nb UP protocol if the anchor MSC or MGW and the visited MSC or MGW are connected via an ATM interface or IP interface. The NbUP shall be configured in support mode, the data is transported in a 64 kbit/s bit stream, formatted in SDUs of 40 octets and transmitted every 5 ms, in accordance with Annex P of ITU-T Recommendation I.366.2 [25]. PDU type 0 is used, i.e., payload CRC is applied. This is needed for the framing to be handled the same for all transports but the Frame Quality Classification control shall be ignored (3GPP property Delivery Of Erroneous SDUs = yes) and therefore interim nodes shall only pass on the CRC. The data is encoded between MSC-B/MGW -B (non-Anchor) and MSC-A/MGW -A (Anchor) as for the TDM case.

### 10.2.2 Handover from A/Gb mode to UTRAN Iu mode

After a handover from A/Gb mode to UTRAN Iu mode the user plane between the anchor MSC and the visited MSC shall comply to:

- the A-TRAU' protocol except for FNUR = 56 kbit/s (ITC=RDI) and FNUR = 64 kbit/s (ITC=UDI). For both exceptions a plain 64 kbit/s channel is used between the MSCs.
- the Nb UP protocol if the anchor MSC or MGW and the visited MSC or MGW are connected via an ATM interface or IP interface. The NbUP shall be configured in support mode, the data is transported in a 64 kbit/s bit stream, formatted in SDUs of 40 octets and transmitted every 5 ms, in accordance with Annex P of ITU-T Recommendation I.366.2 [25]. PDU type 0 is used, i.e., payload CRC is applied. This is needed for the framing to be handled the same for all transports but the Frame Quality Classification control shall be ignored (3GPP property Delivery Of Erroneous SDUs = yes) and therefore interim nodes shall only pass on the CRC. The data is encoded between MSC-B/MGW -B (non-Anchor) and MSC-A/MGW -A (Anchor) as for the TDM case (A-TRAU' protocol or plain 64kbits/s).

The A-TRAU' protocol is defined as follows:

- A-TRAU' frames are transmitted in regular intervals of 10 ms;
- an A-TRAU' frame consists of two consecutive A-TRAU frames (as defined in 3GPP TS 48.020 [19]) each with a length of 320 bit;
- the A-TRAU' protocol is used on a plain 64 kbit/s channel without substreams;
- the same A-TRAU' format is used for the transparent and non-transparent transmission mode;
- in transparent mode the number of data bits in an A-TRAU' frame depend on the user rate only, each user rate corresponds to a fixed number of data bits (see below);
- in non-transparent mode A-TRAU' frames contain always complete RLP frames, rate adaptation is performed by means of the M2 bit;
- the M1-bit is used to identify 1<sup>st</sup> and 2<sup>nd</sup> frame in both transmission modes.

#### 10.2.2.1 Frame layout for the different transparent user rates

The number of data bits in an A-TRAU' frame depend on the user rate only, each user rate corresponds to a fixed number of data bits in an A-TRAU' frame.

Date Rate	Number of data bits per A-TRAU' frame
33,6 kbit/s	336
28,8 kbit/s	288

The data bits are inserted in the A-TRAU' frame starting with D1 of Data field 1 of the first A-TRAU frame. The unused bits are filled with binary '1'.

### 10.2.2.2 A-TRAU' frame format

One A-TRAU' frame consists of two consecutive A-TRAU frames. Figure 8 shows the format of one A-TRAU frame.

Octet number	bit number								
	0	1	2	3	4	5	6	7	
0	0	0	0	0	0	0	0	0	
1	0	0	0	0	0	0	0	0	
2	1	<b>C1</b>	<b>C2</b>	<b>C3</b>	<b>C4</b>	<b>C5</b>	<b>M1</b>	<b>M2</b>	
3	<b>Z1</b>	D1	D2	D3	D4	D5	D6	D7	
4	D8	D9	D10	D11	D12	D13	D14	D15	36 bit data field 1
5	D16	D17	D18	D19	D20	D21	D22	D23	
6	D24	D25	D26	D27	D28	D29	D30	D31	
7	D32	D33	D34	D35	D36	<b>Z2</b>	D1	D2	
8	D3	D4	D5	D6	D7	D8	D9	D10	
9	D11	D12	D13	D14	D15	D16	D17	D18	36 bit data field 2
10	D19	D20	D21	D22	D23	D24	D25	D26	
11	D27	D28	D29	D30	D31	D32	D33	D34	
12	D35	D36	<b>Z3</b>	D1	D2	D3	D4	D5	
13	D6	D7	D8	D9	D10	D11	D12	D13	
14	D14	D15	D16	D17	D18	D19	D20	D21	36 bit data field 3
15	D22	D23	D24	D25	D26	D27	D28	D29	
16	D30	D31	D32	D33	D34	D35	D36	<b>Z4</b>	
17	D1	D2	D3	D4	D5	D6	D7	D8	
18	D9	D10	D11	D12	D13	D14	D15	D16	36 bit data field 4
19	D17	D18	D19	D20	D21	D22	D23	D24	
20	D25	D26	D27	D28	D29	D30	D31	D32	
21	D33	D34	D35	D36	<b>Z5</b>	D1	D2	D3	
22	D4	D5	D6	D7	D8	D9	D10	D11	
23	D12	D13	D14	D15	D16	D17	D18	D19	36 bit data field 5
24	D20	D21	D22	D23	D24	D25	D26	D27	
25	D28	D29	D30	D31	D32	D33	D34	D35	
26	D36	<b>Z6</b>	D1	D2	D3	D4	D5	D6	
27	D7	D8	D9	D10	D11	D12	D13	D14	
28	D15	D16	D17	D18	D19	D20	D21	D22	36 bit data field 6
29	D23	D24	D25	D26	D27	D28	D29	D30	
30	D31	D32	D33	D34	D35	D36	<b>Z7</b>	D1	
31	D2	D3	D4	D5	D6	D7	D8	D9	
32	D10	D11	D12	D13	D14	D15	D16	D17	
33	D18	D19	D20	D21	D22	D23	D24	D25	36 bit data field 7
34	D26	D27	D28	D29	D30	D31	D32	D33	
35	D34	D35	D36	<b>Z8</b>	D1	D2	D3	D4	
36	D5	D6	D7	D8	D9	D10	D11	D12	
37	D13	D14	D15	D16	D17	D18	D19	D20	36 bit data field 8
38	D21	D22	D23	D24	D25	D26	D27	D28	
39	D29	D30	D31	D32	D33	D34	D35	D36	

Figure 8: A-TRAU 320 bit frame

**Data Bits (Dxx):**

The 288 data bits of an A-TRAU frame are divided in eight fields of 36 bits.

**Control bits (C Bits):**

**C1 to C4:**

The Control bits C1 to C4 define the used data rate. C1 to C4 in the first A-TRAU frame indicate the data rate in send direction.

C1 to C4 in the second A-TRAU frame indicate the used data rate in backward direction. This is required for Rate Control that is required in uplink direction. For details on rate control see 3GPP TS 25.415 [13].

C1	C2	C3	C4	Radio Interface User Rate
1	0	1	1	57,6 kbit/s
1	0	1	0	33,6 kbit/s
1	0	0	0	28,8 kbit/s
0	1	1	1	14,4 kbit/s

**C5:**

C5 is not used, it is set to binary '1'.

**Bit M1:**

An A-TRAU' frame is made of two consecutive A-TRAU which build the transport container for 576 data bits. Bit M1 is used to determine the order of the A-TRAU frames within an A-TRAU' frame.

The two M1 bits are referred to as the Frame Start Identifier. The FSI value is 01. These values are assigned to the M1 bit as shown below:

	M1 bit
First A-TRAU frame	0
Second A-TRAU frame	1

**Bit M2:**

The M2 bit is used to indicate 'valid' A-TRAU' frames. The M2 bit in both of the two consecutive A-TRAU frames relating to an A-TRAU' frame shall have the same value.

Transparent mode:

In transparent mode M2 is clamped to binary '0'.

Non-transparent mode:

In non-transparent mode M2 is used for DTX. If DTX is applied, M2 is set to binary '1'. If DTX is not to be applied, M2 bit is set to binary '0'. The DTX handling is used in both directions for rate adaptation purpose. This means that the sending entity will insert 'fill RLP-frames' with DTX set to binary '1' in case no RLP-frame is available.

Fill frames are also sent in order to adapt the RLP transmission frequency to the AIUR. The ratio between RLP frames and 'fill' RLP frames is defined in the following table.

AIUR	Ratio between RLP and 'fill' RLP frames
57.6 kbit/s	Only valid frames
28.8 kbit/s	1 valid frame followed by 1 'fill' frame
14.4 kbit/s	1 valid frame followed by 3 'fill' frames

**Z bits:**

The bits Zi are used for Framing Pattern Substitution mechanism. This mechanism is defined in 3GPP TS 48.020 [19].

**Mapping of A-TRAU' frames to PCM time slots:**



A-TRAU' frames shall be mapped octet aligned to PCM time slots. I.e. bit number 0 to 7 of each octet of an A-TRAU' frame shall be mapped to bit number 0 to 7 of the PCM time slot.

## 10.2.3 Handover from A/Gb mode to GERAN Iu mode

### 10.2.3.1 User plane for transparent services

After a handover from a GERAN A/Gb mode MSC to a GERAN Iu mode MSC the user plane for transparent services between the anchor MSC and the visited MSC shall comply to:

- the A-TRAU' protocol except for FNUR = 32 kbit/s (ITC = UDI), FNUR = 56 kbit/s (ITC=RDI) and FNUR = 64 kbit/s (ITC = UDI). For these exceptions a plain 64 kbit/s channel is used between the MSCs. The rate adaptation between 64 kbit/s and 32 kbit/s is based on ITU-T Recommendation I.460 [26].
- the Nb UP protocol if the anchor MSC or MGW and the visited MSC or MGW are connected via an ATM interface or IP interface. The NbUP shall be configured in support mode, the data is transported in a 64 kbit/s bit stream, formatted in SDUs of 40 octets and transmitted every 5 ms, in accordance with Annex P of ITU-T Recommendation I.366.2 [25]. PDU type 0 is used, i.e., payload CRC is applied. This is needed for the framing to be handled the same for all transports but the Frame Quality Classification control shall be ignored (3GPP property Delivery Of Erroneous SDUs = yes) and therefore interim nodes shall only pass on the CRC. The data is encoded between MSC-B/MGW -B (non-Anchor) and MSC-A/MGW -A (Anchor) as for the TDM case (A-TRAU' protocol or plain 64kbits/s).

### 10.2.3.2 User plane for non-transparent services

After a handover from a GERAN A/Gb mode MSC to a GERAN Iu mode MSC the user plane for non-transparent services between the anchor MSC and the visited MSC shall comply to:

- the A-TRAU'' protocol as defined below for the RAB subflows with 12 kbit/s, 24 kbit/s, 36 kbit/s and 48 kbit/s and the A-TRAU' protocol for the RAB subflows with 14,4 kbit/s, 28,8 kbit/s, 43,2 kbit/s and 57,6 kbit/s, if both MSCs are connected via a TDM interface.
- the Nb UP protocol if the anchor MSC or MGW and the visited MSC or MGW are connected via an ATM interface or IP interface. The NbUP shall be configured in support mode, the data is transported in a 64 kbit/s bit stream, formatted in SDUs of 40 octets and transmitted every 5 ms, in accordance with Annex P of ITU-T Recommendation I.366.2 [25]. PDU type 0 is used, i.e., payload CRC is applied. This is needed for the framing to be handled the same for all transports but the Frame Quality Classification control shall be ignored (3GPP property Delivery Of Erroneous SDUs = yes) and therefore interim nodes shall only pass on the CRC. The data is encoded between MSC-B/MGW -B (non-Anchor) and MSC-A/MGW -A (Anchor) as for the TDM case (A-TRAU'' or A-TRAU' protocol).

#### 10.2.3.2.1 A-TRAU'' frame format

The RLP frame length of 240 bit is used. For the transfer of this RLP frame length the A-TRAU'' protocol is introduced. An A-TRAU'' frame has the same layout as the A-TRAU' frame and contains two A-TRAU frames.

One RLP frame with the length of 240 bit is contained in one A-TRAU frame. The A-TRAU'' protocol is only used for the non-transparent services.

In figure 9, the format of the A-TRAU frame for the RLP frame length of 240 is shown.

Octet number	Bit number								
	0	1	2	3	4	5	6	7	
0	0	0	0	0	0	0	0	0	
1	0	0	0	0	0	0	0	0	
2	1	<b>C1</b>	<b>C2</b>	<b>C3</b>	<b>C4</b>	<b>C5</b>	<b>M1</b>	<b>M2</b>	
3	<b>Z1</b>	D1	D2	D3	D4	D5	D6	D7	36 bit data field 1
4	D8	D9	D10	D11	D12	D13	D14	D15	
5	D16	D17	D18	D19	D20	D21	D22	D23	
6	D24	D25	D26	D27	D28	D29	D30	D31	
7	D32	D33	D34	D35	D36	<b>Z2</b>	D1	D2	36 bit data field 2
8	D3	D4	D5	D6	D7	D8	D9	D10	
9	D11	D12	D13	D14	D15	D16	D17	D18	
10	D19	D20	D21	D22	D23	D24	D25	D26	
11	D27	D28	D29	D30	D31	D32	D33	D34	36 bit data field 3
12	D35	D36	<b>Z3</b>	D1	D2	D3	D4	D5	
13	D6	D7	D8	D9	D10	D11	D12	D13	
14	D14	D15	D16	D17	D18	D19	D20	D21	
15	D22	D23	D24	D25	D26	D27	D28	D29	36 bit data field 4
16	D30	D31	D32	D33	D34	D35	D36	<b>Z4</b>	
17	D1	D2	D3	D4	D5	D6	D7	D8	
18	D9	D10	D11	D12	D13	D14	D15	D16	
19	D17	D18	D19	D20	D21	D22	D23	D24	36 bit data field 5
20	D25	D26	D27	D28	D29	D30	D31	D32	
21	D33	D34	D35	D36	<b>Z5</b>	D1	D2	D3	
22	D4	D5	D6	D7	D8	D9	D10	D11	
23	D12	D13	D14	D15	D16	D17	D18	D19	36 bit data field 6
24	D20	D21	D22	D23	D24	D25	D26	D27	
25	D28	D29	D30	D31	D32	D33	D34	D35	
26	D36	<b>Z6</b>	D1	D2	D3	D4	D5	D6	
27	D7	D8	D9	D10	D11	D12	D13	D14	36 bit data field 7
28	D15	D16	D17	D18	D19	D20	D21	D22	
29	D23	D24	D25	D26	D27	D28	D29	D30	
30	D31	D32	D33	D34	D35	D36	<b>Z7</b>	D1	
31	D2	D3	D4	D5	D6	D7	D8	D9	36 bit data field 8
32	D10	D11	D12	D13	D14	D15	D16	D17	
33	D18	D19	D20	D21	D22	D23	D24	D25	
34	D26	D27	D28	D29	D30	D31	D32	D33	
35	D34	D35	D36	<b>Z8</b>	D1	D2	D3	D4	
36	D5	D6	D7	D8	D9	D10	D11	D12	
37	D13	D14	D15	D16	D17	D18	D19	D20	
38	D21	D22	D23	D24	D25	D26	D27	D28	
39	D29	D30	D31	D32	D33	D34	D35	D36	

Figure 9: Use of A-TRAU frame for RLP frame size of 240 bits

**Data Bits (Dxx):**

The 288 data bits of an A-TRAU frame are divided in eight fields of 36 bits.

Only 240 data bits will be used. The data bits D25 ... D 26 of the data field 7 and the data bits D1 ... D36 of the data field 8 are set to '1' in of transfer of 240 bit long RLP frames.

**Control bits (C Bits):**

**C1 to C4:**

The Control bits C1 to C4 define the used data rate. C1 to C4 in the first A-TRAU frame indicate the data rate in send direction.

C1 to C4 in the second A-TRAU frame indicate the used data rate in backward direction. This is required for Rate Control in uplink direction.

C1	C2	C3	C4	Radio Interface User Rate
1	0	1	1	57,6 bit/s
1	0	0	0	28,8 kbit/s
0	1	1	1	14,4 kbit/s
0	1	1	0	38,4 kbit/s
0	1	0	1	19,2 kbit/s
0	1	0	0	9,6 kbit/s

#### C5:

The C5 bit indicates that the A-TRAU'' protocol is used and one A-TRAU frame contains one RLP frame with the length of 240 bit. In this case C5 is set binary '0'.

#### Bit M1:

For A-TRAU'' the M1 bit in each A-TRAU frame is always set to '1'.

#### Bit M2:

A-TRAU'' protocol is only used in non-transparent mode.

The M2 is used for DTX. If DTX is applied, M2 is set to binary '1'. If DTX is not to be applied, M2 bit is set to binary '0'. The DTX handling is used in both directions for rate adaptation purpose. This means that the sending entity will insert 'fill RLP-frames' with DTX set to binary '1' in case no RLP-frame is available.

Fill frames are also sent in order to adapt the RLP transmission frequency to the AIUR. The ratio between RLP frames and 'fill' RLP frames is defined in the following table for the A-TRAU'' protocol:

AIUR	Ratio between RLP and 'fill' RLP frames
38,4 kbit/s	Each A-TRAU frame is valid
28,8 kbit/s	An A-TRAU'' frame with two valid frames is followed by an A-TRAU'' frame containing one valid frame and one fill frame.
19,2 kbit/s	Each A-TRAU'' frame contains one valid frame and one fill frame.
9,6 kbit/s	An A-TRAU'' frame with one valid frame and one fill frame is followed by an A-TRAU'' frame containing two fill frames

#### Z bits:

The bits Zi are used for Framing Pattern Substitution mechanism. This mechanism is defined in 3GPP TS 48.020 [19].

#### Mapping of A-TRAU' frames to PCM time slots:

A-TRAU'' frames shall be mapped octet aligned to PCM time slots. I.e. bit number 0 to 7 of each octet of an A-TRAU' frame shall be mapped to bit number 0 to 7 of the PCM time slot.

## 10.2.4 Handover within Iu mode PLMNs

After a handover from an Iu mode MSC to a UTRAN Iu mode MSC the user plane between the anchor MSC or MGW and the visited MSC or MGW shall comply to

- the A-TRAU' protocol if both MSC are connected via a TDM interface except for the transparent cases FNUR = 32 kbit/s (ITC = UDI), FNUR = 56 kbit/s (ITC=RDI) and FNUR = 64 kbit/s (ITC=UDI). For these exceptions a plain 64 kbit/s channel is used between the MSCs. The rate adaptation between 64kbit/s and 32kbit/s is based on ITU-T Recommendation I.460 [26].
- the Nb UP protocol if the anchor MSC or MGW and the visited MSC or MGW are connected via an ATM interface or IP interface. The Nb UP shall be configured in support mode, the data is transported in a 64 kbit/s bit stream, formatted in SDUs of 40 octets and transmitted every 5 ms, in accordance with annex P of ITU-T Recommendation I.366.2 [27]. PDU type 0 is used, i.e., payload CRC is applied. This is needed for the framing to be handled the same for all transports but the Frame Quality Classification control shall be ignored (3GPP property Delivery Of Erroneous SDUs = yes) and therefore interim nodes shall only pass on the CRC. The data is encoded between MSC-B/MGW -B (non-Anchor) and MSC-A/MGW -A (Anchor) as for the TDM case (A-TRAU' protocol or plain 64kbit/s).

After a handover from an Iu mode MSC to a GERAN Iu mode MSC the user plane between the anchor MSC or MGW and the visited MSC or MGW shall comply to

- the A-TRAU' or A-TRAU'' protocol or a plain 64 kbit/s channel if both MSC are connected via a TDM interface. The A-TRAU' protocol shall be used for transparent services except for the transparent cases FNUR = 32 kbit/s (ITC = UDI), FNUR = 56 kbit/s (ITC=RDI) and FNUR = 64 kbit/s (ITC=UDI). For these exceptions a plain 64 kbit/s channel shall be used between the MSCs. The rate adaptation between 64kbit/s and 32kbit/s is based on ITU-T Recommendation I.460 [26]. For non-transparent services, the A-TRAU'' protocol shall be used for the RAB subflows with 12 kbit/s, 24 kbit/s, 36 kbit/s and 48 kbit/s and the A-TRAU' protocol shall be used for the RAB subflows with 14,4 kbit/s, 28,8 kbit/s, 43,2 kbit/s and 57,6 kbit/s.
- the Nb UP protocol if the anchor MSC or MGW and the visited MSC or MGW are connected via an ATM interface or IP interface. The Nb UP shall be configured in support mode, the data is transported in a 64 kbit/s bit stream, formatted in SDUs of 40 octets and transmitted every 5 ms, in accordance with annex P of ITU-T Recommendation I.366.2 [27]. PDU type 0 is used, i.e., payload CRC is applied. This is needed for the framing to be handled the same for all transports but the Frame Quality Classification control shall be ignored (3GPP property Delivery Of Erroneous SDUs = yes) and therefore interim nodes shall only pass on the CRC. The data is encoded between MSC-B/MGW -B (non-Anchor) and MSC-A/MGW -A (Anchor) as for the TDM case (A-TRAU'' protocol, A-TRAU' protocol or plain 64kbit/s).

## 10.2.5 Handover for 56 kbit/s

The FNUR = 56 kbit/s in transparent mode can be supported in A/Gb mode by two configurations:

1. without IWF with the following channel codings:
  - 2\*TCH/F32.0
  - 5\*TCH/F9.6
2. with IWF with the following channel coding:
  - 4\*TCH/F14.4

The FNUR = 56 kbit/s in transparent mode is supported in UTRAN Iu mode by a configuration without IWF only. Therefore handover for 56kbit/s in transparent mode between UTRAN Iu mode and A/Gb mode can be supported only for configurations without IWF.

## Annex A: Change history

Change history							
Date	TSG #	TSG Doc.	CR	Rev	Subject/Comment	Old	New
03-2000	TSG#07	NP-000053			Approved to be placed under TSG Change control	2.0.0	3.0.0
06-2000	TSG#08	NP-000223	001		Deletion of T 56 kbit/s for UDI	3.0.0	3.1.0
06-2000	TSG#08	NP-000223	002		Residual bit error ratio in Transparent Data	3.0.0	3.1.0
06-2000	TSG#08	NP-000223	003		Adding the value of GBR of NT services	3.0.0	3.1.0
06-2000	TSG#08	NP-000223	004		Indication of discontinuous transfer for NT data	3.0.0	3.1.0
06-2000	TSG#08	NP-000229	005		Clarification of lu UP in Transparent	3.0.0	3.1.0
06-2000	TSG#08	NP-000223	006		Clarification for 56 and 64 kbit/s	3.0.0	3.1.0
06-2000	TSG#08	NP-000223	007		Alignment with 29.007	3.0.0	3.1.0
06-2000	TSG#08	NP-000229	008		Clarification of lu UP PDU Type for NT data	3.0.0	3.1.0
09-2000	TSG#09	NP-000359	010		Transparent 32 kbit/s data rate with I.460 rate adaptation	3.1.0	4.0.0
09-2000	TSG#09	NP-000369	013		Cleanup of RAB parameter setting	3.1.0	4.0.0
09-2000	TSG#09	NP-000427	015		Delivery of erroneous SDUs parameter value	3.1.0	4.0.0
09-2000	TSG#09	NP-000481	017		3.1 kHz multimedia calls at 33.6 kbit/s data rate	3.1.0	4.0.0
10-2000					Correction to references	4.0.0	4.0.1
12-2000	TSG#10	NP-000605	019		Handover for 56kbit/s	4.0.1	4.1.0
03-2001	TSG#11	NP-010041	021		A-TRAU' correction	4.1.0	4.2.0
03-2001	TSG#11	NP-010043	025		Correction of service's scope	4.1.0	4.2.0
03-2001	TSG#11	NP-010045	026		Introduction of Nb UP	4.1.0	4.2.0
03-2001	TSG#11	NP-010041	027		A-TRAU' correction	4.1.0	4.2.0
03-2001	TSG#11	NP-010042	028		RAB- assignment request (RAB parameter)	4.1.0	4.2.0
06-2001	TSG#12	NP-010255	030		Connection models for CSD and editorial changes.	4.2.0	4.3.0
12-2001	TSG#14	NP-010410	031		SDU size for transparent data at 33.6 kbit/s	4.3.0	4.4.0
12-2001	TSG#14	NP-010410	032	2	Terminology clarifications as requested by TSG GERAN	4.4.0	5.0.0
09-2002	TSG#17	NP-020404	035		Handling of M2 Bit for Handover	5.0.0	5.1.0
09-2002	TSG#17	NP-020404	038		Removal of SDU error ratio for NT services	5.0.0	5.1.0
09-2002	TSG#17	NP-020406	041		Handling of CSD calls and Inter-MSC Relocation	5.0.0	5.1.0
12-2002	TSG#18	NP-020617	039	1	CS Data Services (including HSCSD and EDGE) for GERAN lu mode	5.1.0	5.2.0
12-2002	TSG#18	NP-020616	042	1	Use of lu UP in support mode for transparent data services at the Nb interface	5.1.0	5.2.0
03-2003	TSG#19	NP-030076	045	1	Use of Nb UP protocol after inter-MSC handover	5.2.0	5.3.0
09-2003	TSG#21	NP-030327	047	1	Clarification of Handover description	5.3.0	5.4.0
03-2004	TSG#27	NP-050099	050	3	Nb transport for handover between UMTS and GSM	5.4.0	5.5.0