

3GPP TR 23.885 V11.0.0 (2011-09)

Technical Report

**3rd Generation Partnership Project;
Technical Specification Group Services and System Aspects;
Feasibility Study of Single Radio Voice Call Continuity
(SRVCC) from UTRAN/GERAN to E-UTRAN/HSPA;
Stage 2
(Release 11)**



The present document has been developed within the 3rd Generation Partnership Project (3GPP™) and may be further elaborated for the purposes of 3GPP. The present document has not been subject to any approval process by the 3GPP Organizational Partners and shall not be implemented. This Report is provided for future development work within 3GPP only. The Organizational Partners accept no liability for any use of this Specification. Specifications and Reports for implementation of the 3GPP™ system should be obtained via the 3GPP Organizational Partners' Publications Offices.

Keywords

3GPP, Architecture, SRVCC

3GPP

Postal address

3GPP support office address

650 Route des Lucioles - Sophia Antipolis
Valbonne - FRANCE
Tel.: +33 4 92 94 42 00 Fax: +33 4 93 65 47 16

Internet

<http://www.3gpp.org>

Copyright Notification

No part may be reproduced except as authorized by written permission.
The copyright and the foregoing restriction extend to reproduction in all media.

© 2011, 3GPP Organizational Partners (ARIB, ATIS, CCSA, ETSI, TTA, TTC).
All rights reserved.

UMTS™ is a Trade Mark of ETSI registered for the benefit of its members
3GPP™ is a Trade Mark of ETSI registered for the benefit of its Members and of the 3GPP Organizational Partners
LTE™ is a Trade Mark of ETSI registered for the benefit of its Members and of the 3GPP Organizational Partners
GSM® and the GSM logo are registered and owned by the GSM Association

Contents

Foreword	6
1 Scope	7
2 References.....	7
3 Definitions and abbreviations	8
3.1 Definitions	8
3.2 Abbreviations	8
4 Requirements and Assumptions	8
4.1 Assumptions.....	8
4.2 Architectural requirements.....	8
4.3 Performance requirements	9
4.4 Reverse SRVCC deployment scenarios.....	10
5 Architecture model and reference points	10
5.1 General	10
5.2 Reference architecture	11
5.2.1 3GPP UTRAN/GERAN and E-UTRAN SRVCC architecture.....	11
5.2.2 3GPP UTRAN/GERAN and UTRAN (HSPA) SRVCC architecture	11
5.3 Functional Entities.....	12
5.3.1 MSC Server enhanced for SRVCC	12
5.4 Reference points	12
6 Solutions	12
6.1 Solution 1: Session transfer initiated on E-UTRAN/HSPA	12
6.1.1 Functional Description	12
6.1.2 Information flows.....	13
6.1.2.1 GERAN/UTRAN Attach procedure.....	13
6.1.2.2 E-UTRAN attach procedure.....	13
6.1.2.3 Call establishment procedure in GERAN/UTRAN	13
6.1.2.4 SRVCC from E-UTRAN/HSPA to GERAN/UTRAN.....	14
6.1.2.5 Handover procedure in GERAN/UTRAN.....	14
6.1.2.6 Call flows for SRVCC from UTRAN/GERAN to E-UTRAN	14
6.1.2.6.1 SRVCC handover from GERAN without DTM support to E-UTRAN	14
6.1.2.6.2 SRVCC handover from UTRAN or GERAN with PS handover support to E-UTRAN.....	16
6.1.2.7 Call flows for SRVCC from UTRAN/GERAN to HSPA	18
6.1.2.7.1 SRVCC handover from GERAN without DTM support to HSPA	18
6.1.2.7.2 SRVCC handover from UTRAN or GERAN with PS handover support to HSPA	19
6.2 Solution 2: Session transfer initiated on E-UTRAN/HSPA	20
6.2.0 General	20
6.2.1 Functional Description	21
6.2.2 Information flows.....	21
6.2.2.1 GERAN/UTRAN Attach procedure.....	21
6.2.2.2 E-UTRAN attach procedure.....	21
6.2.2.3 Call establishment procedure in GERAN/UTRAN	21
6.2.2.4 SRVCC from E-UTRAN/HSPA to GERAN/UTRAN.....	22
6.2.2.5 Handover procedure in GERAN/UTRAN.....	22
6.2.2.6 Call flows for SRVCC from UTRAN/GERAN to E-UTRAN	23
6.2.2.6.1 SRVCC handover from GERAN without DTM support to E-UTRAN	23
6.2.2.6.2 SRVCC handover from UTRAN or GERAN with PS handover support to E-UTRAN.....	24
6.3 Solution 3+5: Media anchoring in serving network with Access Transfer Control Functionality	25
6.3.1 Architecture Reference Model.....	25
6.3.2 Functional Entities	26
6.3.2.1 ATCF	26
6.3.2.2 SCC AS	27
6.3.2.3 P-CSCF	27
6.3.2.4 MSC Server enhanced for reverse SRVCC	27

6.3.2.5	SGSN enhanced for rSRVCC	27
6.3.2.6	UE enhanced for rSRVCC	27
6.3.2.7	HSS	28
6.3.2.8	MME/SGSN enhanced for rSRVCC	28
6.3.3	Message Flows	28
6.3.3.1	General principles	28
6.3.3.2	GERAN/UTRAN Attach procedure.....	29
6.3.3.3	E-UTRAN attach procedure.....	29
6.3.3.3a	Informing the source RAN about the possibility to perform rSRVCC.....	29
6.3.3.4	Codec and transport address related procedure	30
6.3.3.4.1	General.....	30
6.3.3.4.2	Information in IMS registration and handover procedure	30
6.3.3.5	Establish a session over CS.....	30
6.3.3.5.1	STN-SR allocated by the ATCF and Transfer Info sent to ATCF	30
6.3.3.5.2	Registration when ATCF involved	31
6.3.3.5.3	Origination procedures when ATCF involved.....	31
6.3.3.5.4	Termination procedures when ATCF involved	32
6.3.3.6	CS – PS Access Transfer Overview	33
6.3.3.6.1	Anchored in ATGW	33
6.3.3.6.2	Not Anchored in ATGW	34
6.3.3.7	Access Transfer Preparation	34
6.3.3.7.1	Access Transfer Preparation Alternative 1	34
6.3.3.7.2	Access Transfer Preparation Alternative 2	36
6.3.3.7.3	Access Transfer Preparation Alternative 3	38
6.3.3.7.4	Access Transfer Preparation Alternative 4	40
6.3.3.7.5	Access Transfer Preparation Alternative 5 (the combination)	43
6.3.3.8	IMS Session Continuity procedure	45
6.3.3.8.0	General.....	45
6.3.3.8.1	Anchored in ATGW	46
6.3.3.8.2	Not Anchored in ATGW	47
6.3.3.9	Identification of serving PS node	48
6.3.3.9.1	Alternative 1: CN nodes based.....	48
6.3.3.9.2	Alternative 2: UE and/or RAN provided information	48
6.3.3.9.3	Alternative 3: RAN provided information.....	49
6.3.4	IMS registration Considerations	50
6.3.4.1	General.....	50
6.3.4.2	ATCF controlled registration.....	50
6.3.4.3	SCC AS controlled registration	51
6.3.4.4	rSRVCC HO Cancellation in case of UE loss of IMS registration	52
6.4	Solution 4: Session transfer by local anchoring with Indirect Forwarding	53
6.4.1	Functional Description	53
6.4.2	Architecture Reference Model.....	54
6.4.2	Information flows	54
6.4.2.1	Initial ATTACH / TA update procedure.....	54
6.4.2.2	Call origination procedure in GERAN/UTRAN	54
6.4.2.3	Call termination procedure in GERAN/UTRAN	56
6.4.2.4	SRVCC handover from UTRAN or GERAN to LTE	57
6.5	Solution 5: IMS procedure is initiated by MSC Server to ATCF	59
6.5.1	Architecture Reference Model.....	59
6.5.1.1	General.....	59
6.5.1.2	Concepts of reverse SRVCC.....	60
6.5.2	Functional Entities	61
6.5.2.1	ATCF	61
6.5.2.2	SCC AS	61
6.5.2.3	S-CSCF	62
6.5.2.4	MSC Server enhanced for reverse SRVCC	62
6.5.2.5	MME.....	62
6.5.2.6	UE enhanced for reverse SRVCC	62
6.5.2.7	UTRAN/GERAN.....	62
6.5.3	Message Flows	63
6.5.3.1	Home control rSRVCC	63
6.5.3.2	RAU/LAU/TAU procedure.....	63

6.5.3.3	GERAN/UTRAN performs handover procedure	63
6.5.3.4	Maintaining IMS Registration	63
6.5.3.5	Preparation of media transfer	63
6.5.3.6	Selection of the ATCF	64
6.5.3.7	Originating sessions in CS	65
6.5.3.7.1	Serving MSC Server is not enhanced for ICS	65
6.5.3.7.2	Serving MSC Server is enhanced for ICS	66
6.5.3.7.3	Serving MSC Server is enhanced for rSRVCC	66
6.5.3.7.4	UE is enhanced for ICS	67
6.5.3.8	Terminating sessions in CS	68
6.5.3.8.1	UE is not enhanced for ICS	68
6.5.3.8.2	UE is enhanced for ICS	69
6.5.3.9	CS - PS Access Transfer.....	70
6.5.3.9.0	Introduction.....	70
6.5.3.9.1	IMS Session Continuity procedure	70
6.5.3.9.2	CS to PS handover procedure	71
6.5.3.9	Failure to complete CS-PS Access Transfer	72
7	Assessment of the solutions	73
7.1	Assessment Criteria	73
7.2	Assessment of the solution 3+5 access transfer preparation alternatives	74
8	Conclusion	77
8.1	General	77
8.2	Access Transfer preparation / How to reserve bearer for VoIP	77
8.3	Source SGSN selection by MSC Server	77
8.4	Maintaining IMS registration over PS access during the CS session	77
8.5	Summary	77
Annex A:	Mechanisms to re-enable E-UTRAN capability.....	78
A.1	Functional description	78
A.2	Information flows.....	79
A.2.1	Proposed signalling flow for Alternative A to re-enable E-UTRAN capabilities using broadcast indicator.....	79
A.2.2	Proposed signalling flow for Alternative B to re-enable E-UTRAN capabilities using NAS indicator.....	80
A.2.3	Proposed signalling flow for Alternative C to re-enable E-UTRAN capabilities using change in RFSP/RAC of the UE	81
Annex B:	Mechanisms for GERAN/UTRAN sending Handover/Relocation Required message...82	
Annex C:	Change history	83

Foreword

This Technical Report has been produced by the 3rd Generation Partnership Project (3GPP).

The contents of the present document are subject to continuing work within the TSG and may change following formal TSG approval. Should the TSG modify the contents of the present document, it will be re-released by the TSG with an identifying change of release date and an increase in version number as follows:

Version x.y.z

where:

- x the first digit:
 - 1 presented to TSG for information;
 - 2 presented to TSG for approval;
 - 3 or greater indicates TSG approved document under change control.
- y the second digit is incremented for all changes of substance, i.e. technical enhancements, corrections, updates, etc.
- z the third digit is incremented when editorial only changes have been incorporated in the document.

1 Scope

The objective of the feasibility study is to investigate a solution for supporting Single Radio Voice Call Continuity (SRVCC) from 3GPP UTRAN/GERAN CS access to 3GPP E-UTRAN/HSPA access, for voice call initiated in LTE/HSPA access and previously handed over to UTRAN/GERAN CS access, as well as for the voice call directly initiated in UTRAN/GERAN CS access.

This Technical Report investigates solutions for SRVCC for voice calls that are anchored in the IMS.

Coordination between the SRVCC for voice call and the handover of non-voice PS bearers is also covered.

2 References

The following documents contain provisions which, through reference in this text, constitute provisions of the present document.

- References are either specific (identified by date of publication, edition number, version number, etc.) or non-specific.
- For a specific reference, subsequent revisions do not apply.
- For a non-specific reference, the latest version applies. In the case of a reference to a 3GPP document (including a GSM document), a non-specific reference implicitly refers to the latest version of that document *in the same Release as the present document*.

- [1] 3GPP TR 21.905: "Vocabulary for 3GPP Specifications".
- [2] 3GPP TS 22.278: "Service requirements for the Evolved Packet System (EPS)".
- [3] 3GPP TS 23.292: "IP Multimedia System (IMS) centralized services; Stage 2".
- [4] 3GPP TS 23.237: "IP Multimedia Subsystem (IMS) Service Continuity; Stage 2".
- [5] 3GPP TS 23.401: "General Packet Radio Service (GPRS) enhancements for Evolved Universal Terrestrial Radio Access Network (E-UTRAN) access".
- [6] 3GPP TS 23.060: "General Packet Radio Service (GPRS); Service description; Stage 2".
- [7] 3GPP TS 23.216: "Single Radio Voice Call Continuity (SRVCC); Stage 2".
- [8] 3GPP TR 23.856: "Feasibility study of SR-VCC enhancements".
- [9] 3GPP TS 23.221: "Architectural requirements (Release 9)".
- [10] 3GPP TS 24.301: "Non-Access-Stratum (NAS) protocol for Evolved Packet System (EPS); Stage 3".
- [11] 3GPP TS 23.228: "IP Multimedia Subsystem (IMS); Stage 2".
- [12] 3GPP TS 25.413: "UTRAN Iu interface Radio Access Network Application Part (RANAP) signalling".
- [13] 3GPP TS 44.018: "Mobile radio interface layer 3 specification; Radio Resource Control (RRC) protocol".
- [14] 3GPP TS 29.280: "Evolved Packet System (EPS); 3GPP Sv interface (MME to MSC, and SGSN to MSC) for SRVCC".

3 Definitions and abbreviations

3.1 Definitions

For the purposes of the present document, the terms and definitions given in TR 21.905 [1] and the following apply. A term defined in the present document takes precedence over the definition of the same term, if any, in TR 21.905 [1].

Reverse Single Radio Voice Call Continuity: Voice call continuity from UTRAN/GERAN access to IMS over E-UTRAN/HSPA access for calls that are anchored in IMS when the UE is capable of transmitting/receiving on only one of those access networks at a given time. This is also referred to as Single Radio Voice Call Continuity from E-UTRAN/HSPA to UTRAN/GERAN in this technical report.

Single Radio Voice Call Continuity: Voice call continuity from IMS over E-UTRAN/HSPA access to UTRAN/GERAN access for calls that are anchored in IMS when the UE is capable of transmitting/receiving on only one of those access networks at a given time. This is also referred to as Single Radio Voice Call Continuity from UTRAN/GERAN to E-UTRAN/HSPA in this technical report.

Service Continuity: see TS 22.278 [2].

3.2 Abbreviations

For the purposes of the present document, the abbreviations given in TR 21.905 [1] and the following apply. An abbreviation defined in the present document takes precedence over the definition of the same abbreviation, if any, in TR 21.905 [1].

rSRVCC	Reverse Single Radio Voice Call Continuity
SRVCC	Single Radio Voice Call Continuity

4 Requirements and Assumptions

4.1 Assumptions

For SRVCC from 3GPP UTRAN/GERAN CS access to 3GPP E-UTRAN/HSPA access shall re-use existing functions defined for SRVCC from E-UTRAN/HSPA to UTRAN/GERAN in TS 23.216 [7] as much as possible. The solution shall minimize impacts to Rel-8 SRVCC mechanisms. The results of the study on performance enhancements in TR 23.856 [8] shall be taken into account in this study. The following scenarios shall be studied:

- SRVCC from GERAN without DTM support to E-UTRAN.
- SRVCC from UTRAN/GERAN with PS HO support to E-UTRAN.
- SRVCC from GERAN without DTM support to UTRAN (HSPA).
- SRVCC from UTRAN/GERAN with PS HO support to UTRAN (HSPA).

It is assumed that the support of IMS voice over PS Session is homogeneous in the E-UTRAN network.

4.2 Architectural requirements

- The rSRVCC solution shall not require UE with multiple RATs capability to simultaneously signal on two different RATs.
- Impact on user service quality experience, e.g. QoS, call drop, interruption time, should be minimized.
- Overall duration of the 3GPP UTRAN/GERAN CS access to 3GPP E-UTRAN/HSPA access handover procedure shall be minimized.

- RAT/domain selection change shall be network initiated and under network control.
- In case where the UE has disabled its E-UTRAN capability due to mismatch with the voice capabilities of the network, it shall be able for the UE to re-enable its E-UTRAN capability.
- It shall be possible to restrict RAT/domain selection change to specific access systems and specific subscribers, depending on operator policies (for example restrict handover of voice calls from UTRAN/GERAN CS access to PS domain) and capabilities of the network and the UE, and these shall be network initiated and under network control.
- In roaming cases, the VPLMN shall be able to control the RAT/domain selection change while taking into account any related HPLMN policies. In particular, the HPLMN shall be able to restrict handover to PS domain for a given VPLMN.
- E-UTRAN shall not be required to convert any CS specific RAB information for rSRVCC operation.
- Handovers from UTRAN/GERAN CS access to E-UTRAN/HSPA for voice call initiated in LTE and previously handed over to UTRAN/GERAN CS access as well as for voice calls directly initiated in UTRAN/GERAN CS access shall be supported, provided that the calls have been anchored in IMS at the time of their establishment (for example in the case of voice calls directly initiated in UTRAN/GERAN CS access the MSC Server has been enhanced for ICS).
- The signalling to the HPLMN for inter-domain handover in the VPLMN should be minimized.
- Impacts to Rel-10 SRVCC mechanisms shall be minimized.
- For calls that have been handed over from PS via SRVCC, provided that the UE and the network support rSRVCC procedures, rSRVCC should be possible no matter which SRVCC Release 10 procedure applied:
 - ATCF with media anchored in the ATGW
 - ATCF without media anchored in the ATGW
 - ATCF not included at registration or no ATCF (i.e. SRVCC Release 9 architecture)

NOTE 1: In some of the aforementioned scenarios, the performance requirements might not always be possible to fulfill.

- In case of active PS bearer(s) on UTRAN/GERAN, PS bearer handover to E-UTRAN/HSPA shall be handled as specified in TS 23.401 [5] in conjunction with SRVCC to E-UTRAN/HSPA as specified in TS 23.216 [7]. The rSRVCC solution shall not impact the PS bearer handover.
- The solution shall be applicable to networks where UTRAN/GERAN PS domain cannot provide IMS voice service.
- After transfer from UTRAN/GERAN CS domain to E-UTRAN/HSPA PS-domain, it shall support moving the session back to UTRAN/GERAN CS domain..
- The solution shall support the MSC to initiate reverse SRVCC due to traffic reasons (e.g., for capacity reason, re-enabling high speed broadband access when LTE is available)
- The solution shall support the UE to return to the source BSS/RAN when HO failed and shall not cause any audible disruption on the voice call.

4.3 Performance requirements

The RAT change procedure executed to enable **Service Continuity** for an established voice call shall target an interruption time not higher than 300 ms.

4.4 Reverse SRVCC deployment scenarios

This section details the most likely reasons that can lead operators to deploy rSRVCC, and the handover scenarios which are most important in the different cases:

1) Providing users better service:

As packet services are better provided over E-UTRAN/HSPA, the operator deploys rSRVCC to make sure that users get service on E-UTRAN/HSPA as soon as E-UTRAN/HSPA becomes available (i.e. typically when the E-UTRAN/HSPA cell quality is better than a given threshold).

2) Optimizing network usage:

The operator wants to minimize the CS core network usage and to optimize the radio network usage, so it chooses to handover calls to PS as soon as E-UTRAN/HSPA becomes available. (i.e. typically when the E-UTRAN/HSPA cell quality is better than a given threshold)

3) Enhancing coverage:

The operator wants to enhance its radio coverage by adding the possibility to handover calls to E-UTRAN where GERAN/UTRAN coverage is getting weak.

It could either be that the E-UTRAN cell quality is getting better than the GERAN/UTRAN cell quality, or that the GERAN/UTRAN cell quality gets worse than a given threshold, while the E-UTRAN cell quality is better than another one.

It is expected that scenarios 1) and 2) will be the most common, and consequently, that even if coverage triggered rSRVCC handovers are expected to occur, they should not be the most frequent.

5 Architecture model and reference points

5.1 General

The architecture for SRVCC from UTRAN/GERAN to E-UTRAN/HSPA reuses the architecture model as defined in TS 23.216 [7].

The overall model and impacts to the various elements is provided in the following clauses.

5.2 Reference architecture

5.2.1 3GPP UTRAN/GERAN and E-UTRAN SRVCC architecture

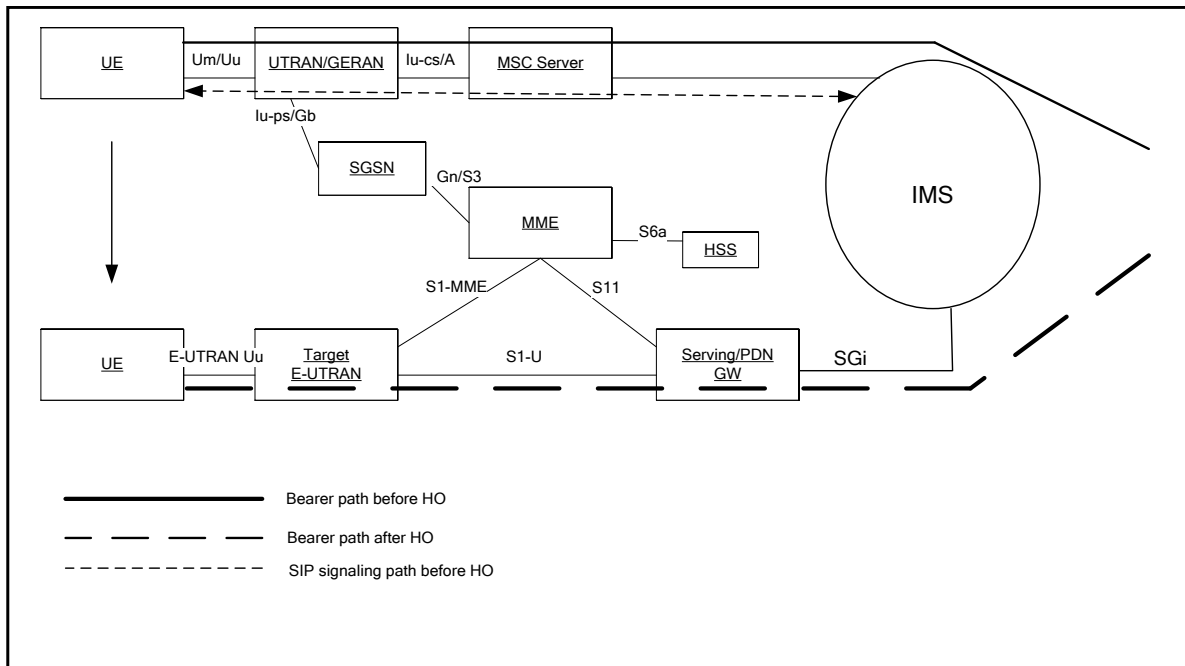

- NOTE 1: The following figure only shows the necessary components related to MSC Server enhanced with SRVCC.
 NOTE 2: MSC Server shown in the figure is enhanced for SRVCC.
 NOTE 3: This architecture also applies to roaming scenario (i.e. S8, S6a are not impacted due to SRVCC).
 NOTE 4: Both Gn-SGSN and S4-SGSN are supported.

Figure 5.2.1-1: SRVCC architecture for UTRAN/GERAN to E-UTRAN

5.2.2 3GPP UTRAN/GERAN and UTRAN (HSPA) SRVCC architecture

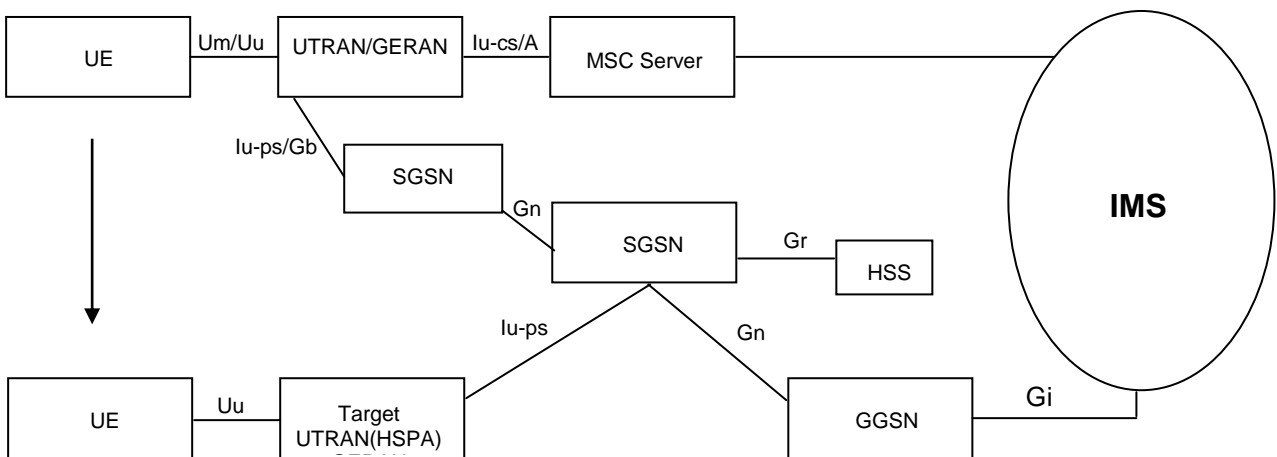
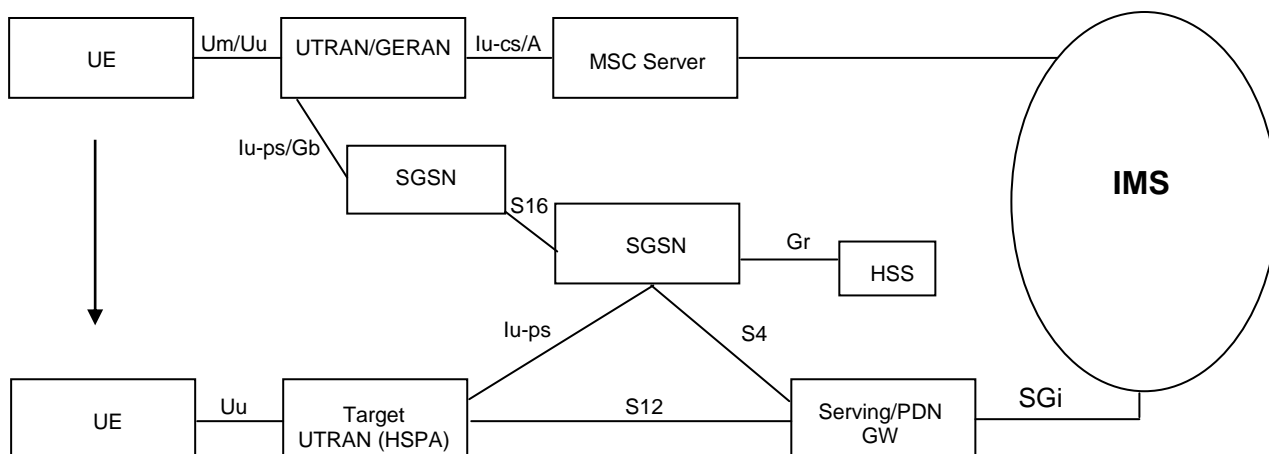

Figure 5.2.2-1: SRVCC architecture for UTRAN/GERAN to UTRAN (HSPA) with Gn based SGSN



NOTE 1: The above figures only show the necessary components related to MSC Server enhanced with SRVCC.

NOTE 2: MSC Server shown in the above figures are enhanced for SRVCC.

NOTE 3: This architecture also applies to roaming scenario.

Figure 5.2.2-2: SRVCC architecture for UTRAN/GERAN to UTRAN (HSPA) with S4 based SGSN

5.3 Functional Entities

NOTE: IMS components are not described here. Please refer to TS 23.237 [4] and TS 23.292 [3].

5.3.1 MSC Server enhanced for SRVCC

In addition to the standard MSC Server behaviour defined in TS 23.216 [7], an MSC Server which has been enhanced for SRVCC from UTRAN/GERAN to E-UTRAN/HSPA provides the following functions:

- Handling the Relocation Preparation procedure requested for the voice component from BSC/RSC via Sv reference point;

5.4 Reference points

No reference point is introduced for the purpose of SRVCC from UTRAN/GERAN CS access to E-UTRAN/HSPA access.

6 Solutions

6.1 Solution 1: Session transfer initiated on E-UTRAN/HSPA

6.1.1 Functional Description

A prerequisite for calls to be possible to handover from UTRAN/GERAN to E-UTRAN/HSPA is that they have been anchored in IMS at the time of their establishment. For calls established on the UTRAN/GERAN side with no voice over IMS support implies the existence of ICS capabilities in the network or in the UE.

Editor's Note: The functional description of the MSC enhanced for rSRVCC and of the UE enhanced for rSRVCC need to be added to this section.

6.1.2 Information flows

6.1.2.1 GERAN/UTRAN Attach procedure

The UTRAN/GERAN Attach procedure for an SRVCC from UTRAN/GERAN to E-UTRAN capable UE is performed as defined in clause 6.5 of TS 23.060 [6] with the following additions:

- 1) The UE indicates to the network its capability to perform SRVCC from UTRAN/GERAN to E-UTRAN as follows:
 - a) In case of a network of Network Mode of Operation type I:
 - The "rSRVCC capability indication" is sent by the UE in the Attach Request message sent to the SGSN at combined GPRS/IMSI Attach, and in the Routing Area Update Request message at combined RA/LA Update.
 - If received by the SGSN, the "rSRVCC capability indication" is transmitted by the SGSN to the MSC in the Location Updating procedure.
 - b) In case of a network of Network Mode of Operation types II or III:
 - The "rSRVCC capability indication" is sent by the UE in the Location Updating Request it sends to the network.
- 2) If the subscriber is allowed to have rSRVCC in the VPLMN, the HSS shall include the "rSRVCC allowed" indication in the Insert Subscriber Data sent to the MSC at Attach or at Location Area Update.
- 3) The MSC enhanced for rSRVCC shall subscribe to the registration event package at Attach or Location Area Update. This will be used for it to monitor the IMS registration status of the UE.

Editor's Note: Whether this is possible in case the MSC does not register the user on behalf of the UE (as an MSC enhanced for ICS does) is FFS.

Editor's Note: Whether the MSC can correlate the registration status received from the SCC AS with the identity used by the UE in the ongoing session is FFS.

6.1.2.2 E-UTRAN attach procedure

The E-UTRAN attach procedure for 3GPP rSRVCC UE is performed as defined in clause 6.3.1 of TS 23.216 [7] with the following additions:

- 1) rSRVCC UE includes the "rSRVCC capability indication" as part of the "MS Network Capability" in the Attach Request message and in Tracking Area Updates.
- 2) If the subscriber is allowed to have rSRVCC in the VPLMN, the HSS shall include the "rSRVCC allowed" indication as part of the subscription data sent to the MME.

6.1.2.3 Call establishment procedure in GERAN/UTRAN

If the MSC server enhanced for rSRVCC determines that rSRVCC is allowed for a given call, it shall include an "rSRVCC possible indication" to the RNS/BSS at call set up to/from an rSRVCC capable UE in:

- 1) The RAB Assignment Message sent over the Iu-CS interface for a network in Iu mode.
- 2) The Assignment Request sent over the A interface for a network in A/Gb mode.

The setting of the "rSRVCC possible indication" by the MSC shall at least take into account the following elements:

- 1) rSRVCC capability of the UE

The "rSRVCC capability indication" is received from the GERAN/UTRAN to E-UTRAN SRVCC capable UE at Attach or Location Area Update, see clause 6.1.2.1.

- 2) Authorization of the user for rSRVCC

The "rSRVCC allowed" information is received from the GERAN/UTRAN to E-UTRAN SRVCC capable UE at Attach or Location Area Update, see clause 6.1.2.1.

3) Prior anchoring of a voice call in the SCC AS

At call establishment, the rSRVCC capable MSC server shall consider the call as anchored in the SCC AS in the two following cases:

- a) The voice call was initiated by the UE on UTRAN/GERAN using CS domain procedures and the MSC has itself anchored using ICS procedures (which can only be the case if the MSC is enhanced for ICS).
- b) The voice call was initiated on GERAN/UTRAN by a UE enhanced for ICS, using the Gm or the I1 interface for service control purposes.

To enable the MSC enhanced for rSRVCC to distinguish such calls, rSRVCC capable UEs which are also ICS capable (as defined in TS 23.292 [3]) shall include an "IMS anchoring performed" indicator in a CS CALL SETUP message corresponding to bearer control signalling for a call established using Gm or I1. The presence of that indicator shall be understood by the MSC enhanced for rSRVCC as the fact that the UE has anchored the call in IMS using ICS capabilities.

4) IMS registration status of the UE

Additionally, operator policies or local policies could be used for the MSC enhanced for rSRVCC in setting the "rSRVCC possible indication" sent towards the RNS/BSS at call establishment.

The BSS/RNS shall use that indication to decide for which cells the UE shall report measurements, as a basis for triggering a SRVCC handover from GERAN/UTRAN to E-UTRAN/HSPA.

6.1.2.4 SRVCC from E-UTRAN/HSPA to GERAN/UTRAN

The procedures defined in 6.2 and 6.3 of TS 23.216 [7] apply with the following additions:

If received from the UE and the HSS respectively, the MME/SGSN shall include the "rSRVCC capability indication" as well as the "rSRVCC allowed" in the SRVCC PS to CS Request it sends to the target MSC (via the MSC enhanced for SRVCC).

In case the MSC server enhanced for rSRVCC determines that rSRVCC is allowed for a given call, it shall include an "rSRVCC possible indication" to the RNS/BSS in the Handover Request/Iu Relocation Request it sends towards the BSS/RNS.

Once the SRVCC handover procedure is over, the MSC enhanced for rSRVCC shall subscribe to the registration event package at Attach or Location Area Update. This will be used for it to monitor the IMS registration status of the UE.

Editor's Note: Whether this is possible in case the MSC does not register the user on behalf of the UE (as an MSC enhanced for ICS does) is FFS.

Editor's Note: Whether the MSC can correlate the registration status received from the SCC AS with the identity used by the UE in the ongoing session is FFS.

6.1.2.5 Handover procedure in GERAN/UTRAN

If the CS domain call is subject to radio-level handover (e.g. intra-RAT, inter-RAT, intra-MSC, inter-MSC, etc) while remaining in the CS domain, the "rSRVCC possible indication" needs to be forwarded to the target radio access (RNS/BSS) provided that it still applies.

Editor's Note: The way this information is conveyed needs to be further detailed.

6.1.2.6 Call flows for SRVCC from UTRAN/GERAN to E-UTRAN

6.1.2.6.1 SRVCC handover from GERAN without DTM support to E-UTRAN

Depicted in Figure 6.1.2.6.1-1 is a call flow for SRVCC handover from GERAN without DTM support to E-UTRAN.

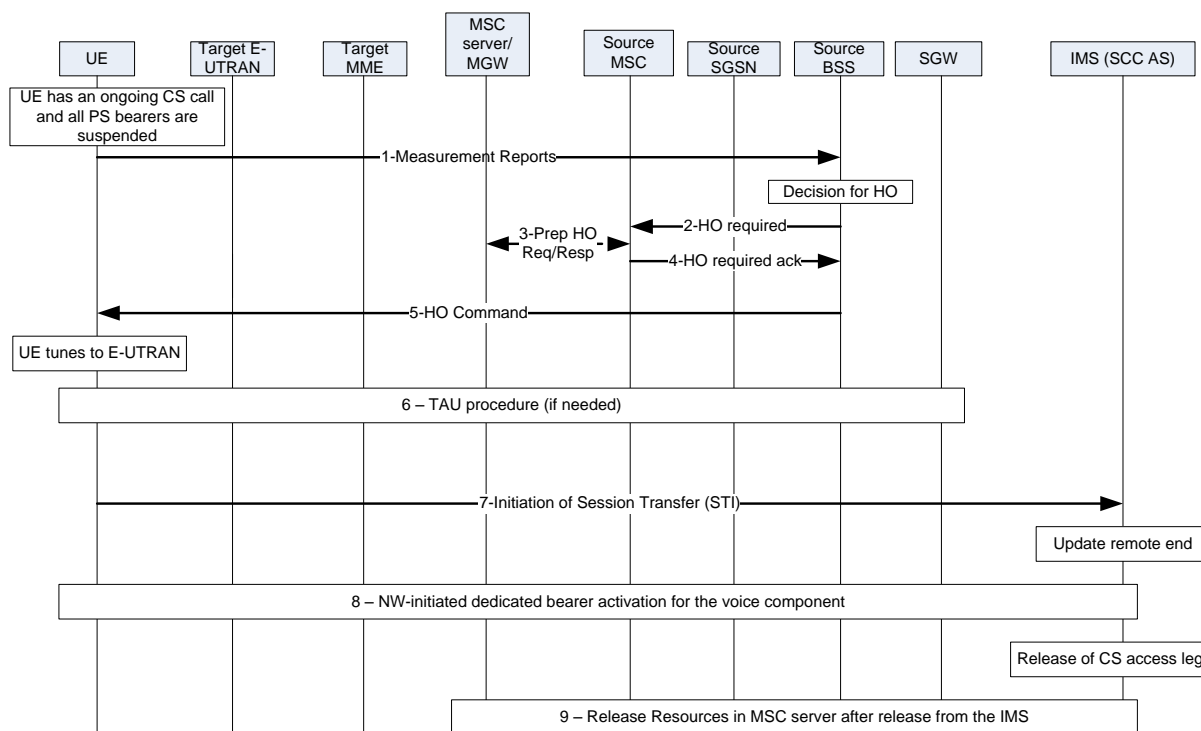

Figure 6.1.2.6.1-1: SRVCC handover from GERAN without DTM support to E-UTRAN

At the beginning of the call flow, all PS bearers are suspended. The source system is configured to know that the target MME/TA where the UE is moving support IMS VoIP.

1. Based on UE measurement reports the source BSS decides to trigger a handover to E-UTRAN.
2. Source BSS sends a Handover Required (Source to Target Transparent Container) message to the source MSC.
3. Source MSC executes the inter-MSC handover procedure by exchanging Prepare HO Request/ Response messages with the MSC Server. The MSC server checks whether the IMS registration of the user on the UE is still valid or not. In case it is not, it rejects the handover request, indicating in the cause value that rSRVCC is not possible any longer. That should trigger the RAN to reconfigure the cells the UE shall measure. If the IMS registration is still valid, the MSC Server signals successful CS handover without allocating any E-UTRAN resources.
4. Source MSC sends a Handover Required Acknowledge message to the source BSS.
5. Source BSS sends a Handover Command to the UE instructing it to perform a CS to PS handover to E-UTRAN. Note that this message does not contain any transparent container information.
6. UE re-tunes to E-UTRAN radio and performs a TAU procedure as specified in TS 23.401 [5]. UE uses the Active flag in the TAU Request to MME to resume the suspended SIP signalling bearer and any other suspended non-voice bearers. The MME requests the context from the source SGSN. The MME will inform S-GW and PDN-GW(s) to resume the suspended bearers
7. Subsequently UE initiates the Session Transfer procedure e.g. by sending a SIP INVITE (STI) message to the SCC AS. Standard IMS Service Continuity procedures are applied for execution of the Session Transfer, see TS 23.237 [4]. As part of this procedure the remote end is updated with the SDP of the IMS access leg. The downlink flow of VoIP packets is switched towards the PDN GW at this point.
8. The IMS triggers a network-initiated dedicated bearer activation for the voice component.
9. The IMS releases the CS access leg which result in release of resources in the MSC Server.

6.1.2.6.2 SRVCC handover from UTRAN or GERAN with PS handover support to E-UTRAN

Depicted in Figure 6.1.2.6.2-1 is a call flow for SRVCC handover from UTRAN or GERAN with PS handover support to E-UTRAN, including the handling of the non-voice component. E-UTRAN neighbouring cells have to be configured in UTRAN/GERAN for the purpose of measurements. The source system is configured to know that the target MME/TA where the UE is moving support IMS VoIP.

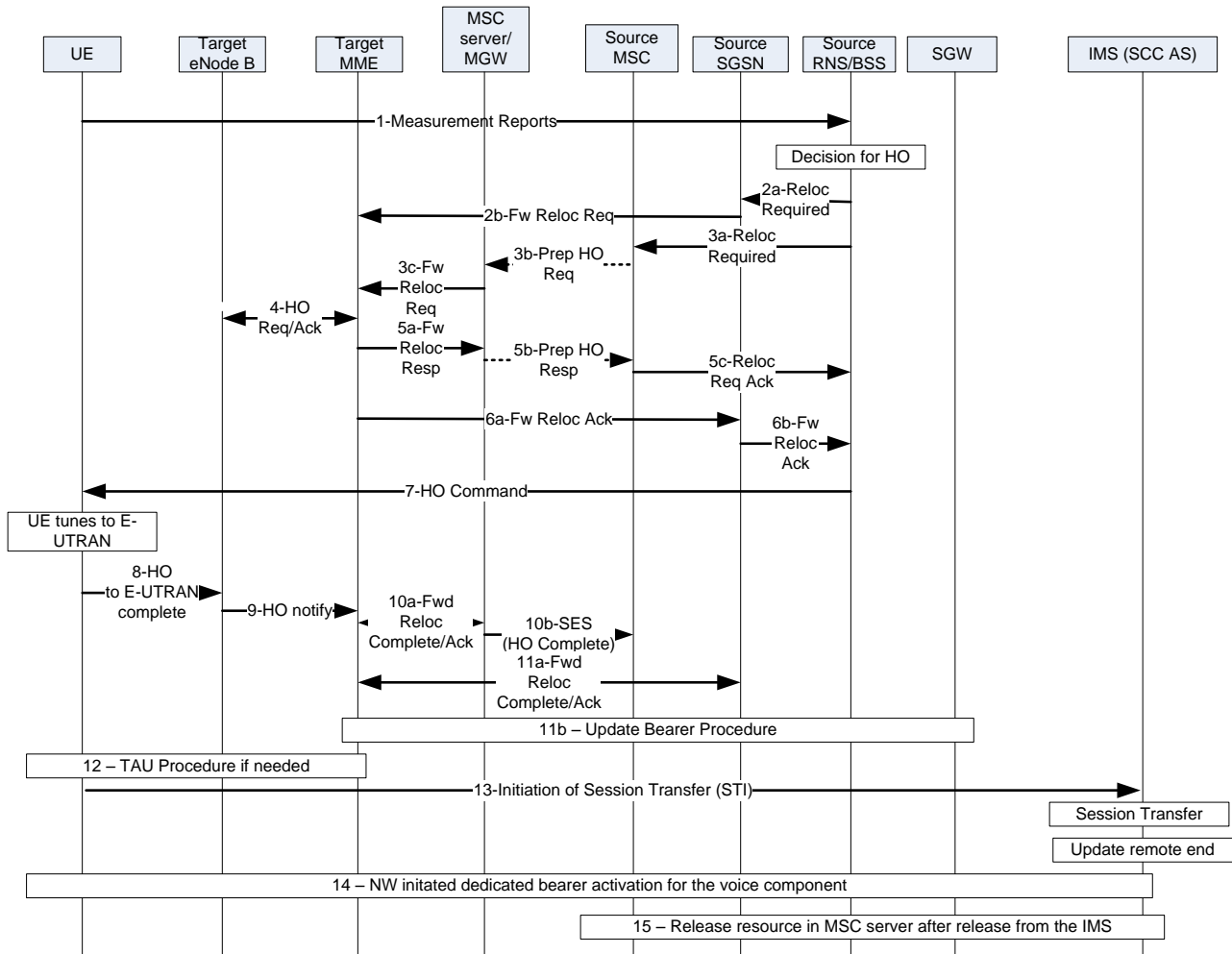

Figure 6.1.2.6.2-1: SRVCC handover from UTRAN or GERAN with PS handover support to E-UTRAN

- Based on UE measurement reports the RNS/BSS decides to trigger a handover to E-UTRAN.
- Source RNS initiates PS relocation. The following steps are performed:
 - Source RNS/BSS sends a Relocation Required (Source to Target Transparent Container) message to source SGSN.
 - Source SGSN sends a Forward Relocation Request message to the target MME including information about the non-voice component only.
- In parallel to the previous step, the source RNS/BSS initiates CS relocation. The following steps are performed:
 - Source RNS/BSS sends a Relocation Required (Source to Target Transparent Container) message to the source MSC.
 - Source MSC sends a Prepare HO Request to the MSC Server.
 - The MSC server checks whether the IMS registration of the user on the UE is still valid or not. In case it is not, it shall reject the handover request, indicating in the cause value that rSRVCC is not possible any longer. That should trigger the RAN to cancel the relocation procedure that was started towards the SGSN and to

reconfigure the cells the UE shall measure. In case the IMS registration is still valid, the MSC Server sends a Forward Relocation Request (Source to Target Transparent Container) message to the target MME.

4. Target MME synchronises the two Forward Relocation Request messages and requests resource allocation for the non-voice component only by exchanging Handover Request/Acknowledge messages with the target E-UTRAN.
5. Target MME acknowledges the prepared CS relocation towards the source access. The following steps are performed:
 - a) Target MME sends a Forward Relocation Response (Target to Source Transparent Container) message to the MSC Server.
 - b) MSC Server sends a Prepare HO Response to the source MSC.
 - c) Source MSC sends a Relocation Required Acknowledge (Target to Source Transparent Container) message to source RNS/BSS.
6. In parallel to the previous step, the target MME acknowledges the prepared PS relocation towards the source access. The following steps are performed:
 - a) Target MME sends a Forward Relocation Response (Target to Source Transparent Container) message to the source SGSN.
 - b) Source SGSN sends a Relocation Required Acknowledge (Target to Source Transparent Container) message to the source RNS/BSS.
7. Source RNS/BSS synchronises the two Relocation Required Acknowledge messages and sends a HO Command message to the UE instructing it to perform a handover to E-UTRAN, including the relocation of the voice bearer to the PS domain.
8. UE re-tunes to E-UTRAN radio and sends a Handover to E-UTRAN Complete message to the E-UTRAN.
9. Target E-UTRAN informs the target MME by sending a Handover Notify message.
10. Target MME completes the CS relocation. The following steps are performed:
 - a) Target MME sends a Forward Relocation Complete message to the MSC Server. MSC Server acknowledges the information by sending a Forward Relocation Complete Acknowledge message to the source MME.
 - b) MSC Server sends a Handover Complete message to the source MSC.
11. In parallel to the previous step the target MME completes the PS relocation. The following steps are performed:
 - a) Target MME exchanges Forward Relocation Complete / Acknowledge messages with the source SGSN.
 - b) Target MME performs the Update bearer procedure with the Serving GW and the PDN GW. At this point the relocation of all non-voice PS bearers is completed and the user data are flowing across E-UTRAN access in both directions.
12. UE performs a TAU procedure if required (e.g. due to UE mobility under CS coverage).
13. UE initiates the Session Transfer procedure e.g. by sending a SIP INVITE (STI) message to the SCC AS. Standard IMS Service Continuity procedures are applied for execution of the Session Transfer, see TS 23.292 [3] and TS 23.237 [4]. As part of this procedure the remote end is updated with the SDP of the IMS access leg. The downlink flow of VoIP packets is switched towards the PDN GW at this point. This step can occur in parallel with step 12.
14. The IMS triggers a network-initiated dedicated bearer for the voice component.
15. The IMS releases the CS access leg which result in release of resources in the MSC Server.

6.1.2.7 Call flows for SRVCC from UTRAN/GERAN to HSPA

6.1.2.7.1 SRVCC handover from GERAN without DTM support to HSPA

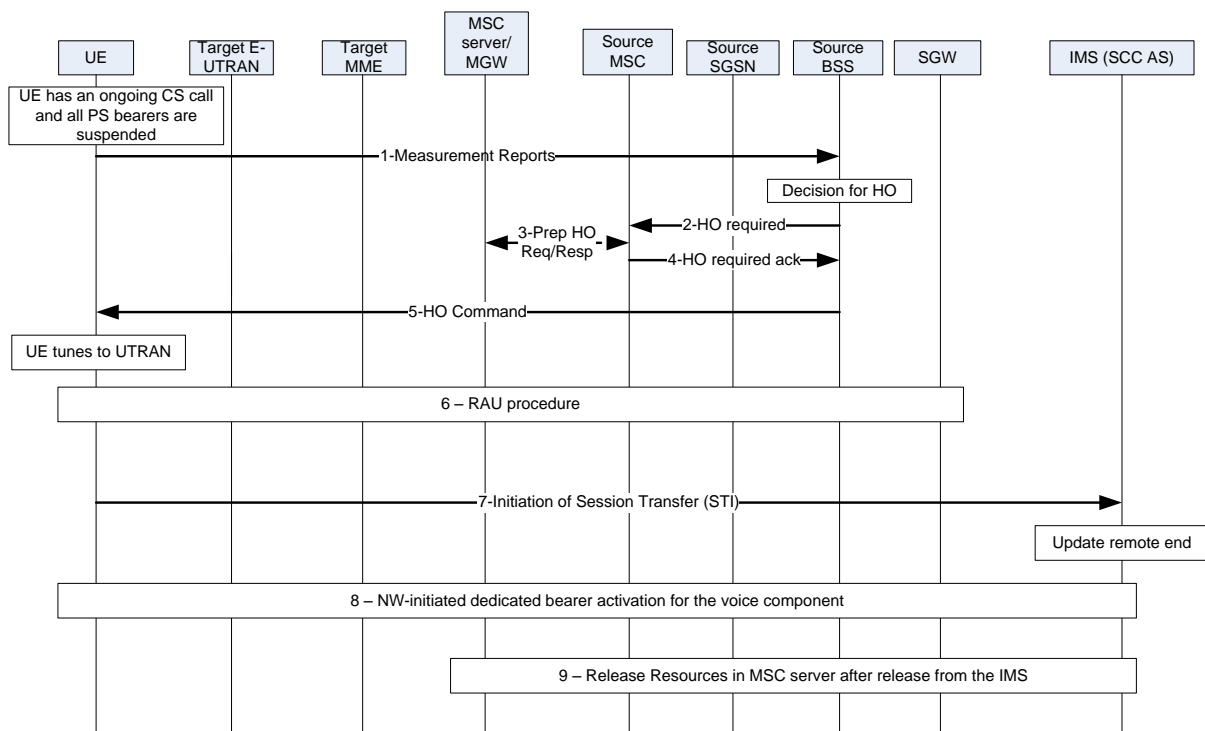

Figure 6.1.2.7.1-1: SRVCC handover from GERAN without DTM support to HSPA

At the beginning of the call flow all PS bearers are suspended. The source system is configured to know that the target MME/TA where the UE is moving support IMS VoIP.

1. The UE reports that a UTRAN has now good quality by sending a Measurement Report to the BSS. Based on that input, the BSS decides to trigger SRVCC to UTRAN/HSPA.
2. Source BSS sends a Handover Required (Source to Target Transparent Container) message to the source MSC.
3. Source MSC executes the inter-MSC handover procedure by exchanging Prepare HO Request/ Response messages with the MSC Server. The MSC server checks whether the IMS registration of the user on the UE is still valid or not. In case it is not, it shall reject the handover request, indicating in the cause value that rSRVCC is not possible any longer. That should trigger the RAN to reconfigure the cells the UE shall measure. In case the IMS registration is still valid, the MSC Server signals successful CS handover without allocating any E-UTRAN resources.
4. Source MSC sends a Handover Required Acknowledge message to the source BSS.
5. Source BSS sends a Handover Command to the UE. The Handover Command includes an indication that this is a CS to PS handover.
6. UE re-tunes to UTRAN radio and performs a RAU procedure to resume the suspended SIP signalling bearer and any other suspended non-voice bearers.
7. Subsequently UE initiates the Session Transfer procedure e.g. by sending a SIP INVITE (STI) message to the SCC AS. Standard IMS Service Continuity procedures are applied for execution of the Session Transfer, see TS 23.292 [3] and TS 23.237 [4]. As part of this procedure the remote end is updated with the SDP of the IMS access leg. The downlink flow of VoIP packets is switched towards the PDN GW at this point.
8. The IMS triggers network-initiated dedicated bearer activation for the voice component.
9. The IMS releases the CS access leg which result in release of resources in the MSC Server.

6.1.2.7.2 SRVCC handover from UTRAN or GERAN with PS handover support to HSPA

Depicted in Figure 6.1.2.3.2-1 is a call flow for SRVCC handover from UTRAN or GERAN with PS handover support to HSPA, including the handling of the non-voice component. The source system is configured to know that the target MME/TA where the UE is moving support IMS VoIP.

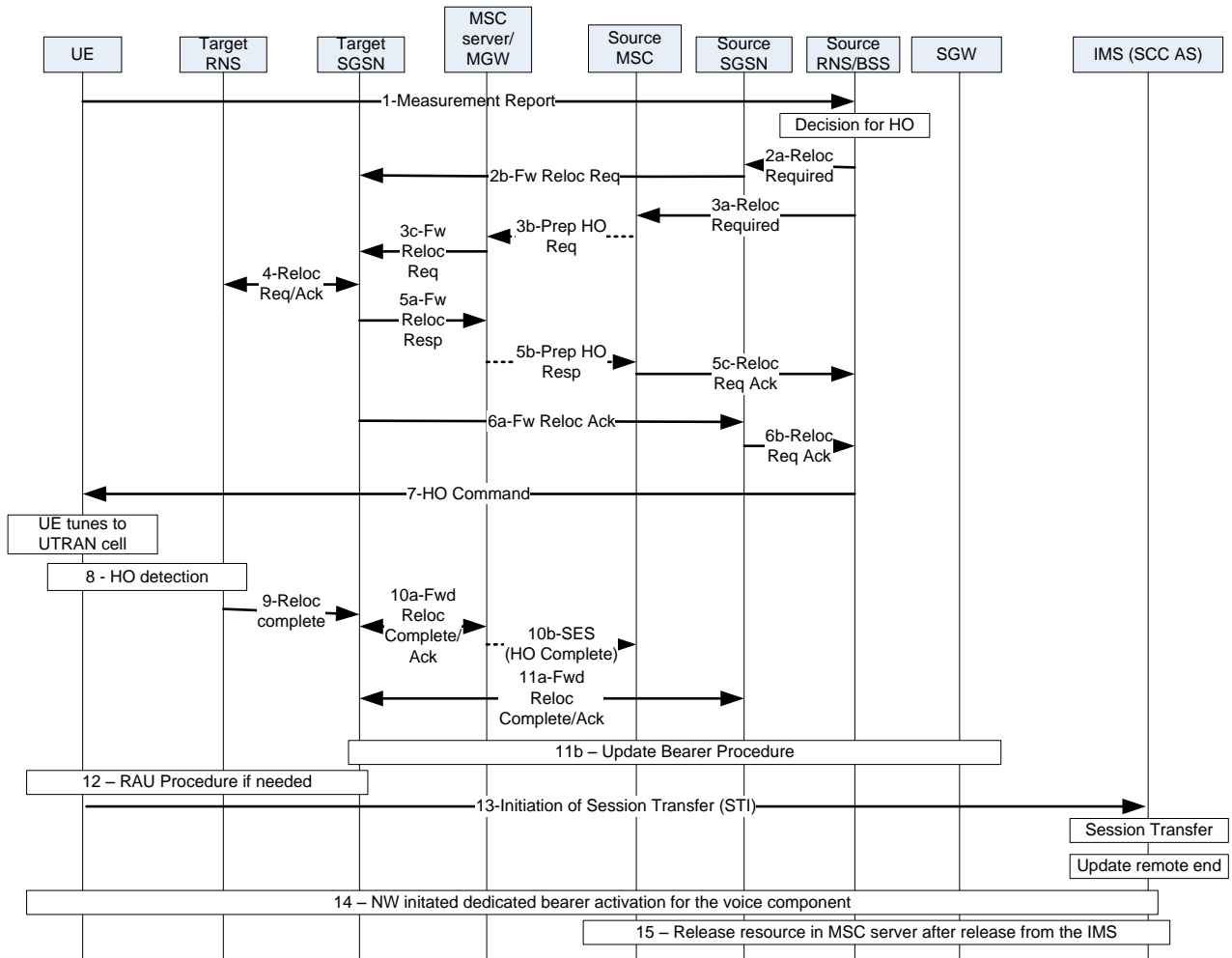

Figure 6.1.2.7.2-1: SRVCC handover from UTRAN or GERAN with PS handover support to HSPA

1. Based on UE measurement reports the RNS decides to trigger a handover to UTRAN/HSPA.
2. Source RNS initiates PS relocation. The following steps are performed:
 - a) Source RNS sends a Relocation Required (Source to Target Transparent Container) message to source SGSN.
 - b) Source SGSN sends a Forward Relocation Request message to the target SGSN including information about the non-voice component only.
3. In parallel to the previous step, the source RNS initiates CS relocation. The following steps are performed:
 - a) Source RNS sends a Relocation Required (Source to Target Transparent Container) message to the source MSC.
 - b) Source MSC sends a Prepare HO Request to the MSC Server.
 - c) The MSC server checks whether the IMS registration of the user on the UE is still valid or not. In case it is not, it shall reject the handover request, indicating in the cause value that rSRVCC is not possible any longer. That should trigger the RAN to cancel the relocation procedure that was started towards the SGSN and to reconfigure the cells the UE shall measure. In case the IMS registration is still valid, the MSC Server sends a Forward Relocation Request (Source to Target Transparent Container) message to the target SGSN.

4. Target SGSN synchronises the two Forward Relocation Request messages and requests resource allocation for the non-voice component only by exchanging Handover Request/Acknowledge messages with the target E-UTRAN.
5. Target SGSN acknowledges the prepared CS relocation towards the source access. The following steps are performed:
 - a) Target SGSN sends a Forward Relocation Response (Target to Source Transparent Container) message to the MSC Server.
 - b) MSC Server sends a Prepare HO Response to the source MSC.
 - c) Source MSC sends a Relocation Required Acknowledge (Target to Source Transparent Container) message to source RNS.
6. In parallel to the previous step, the target SGSN acknowledges the prepared PS relocation towards the source access. The following steps are performed:
 - a) Target SGSN sends a Forward Relocation Response (Target to Source Transparent Container) message to the source SGSN.
 - b) Source SGSN sends a Relocation Required Acknowledge (Target to Source Transparent Container) message to the source RNS.
7. Source RNS synchronises the two Relocation Required Acknowledge messages and sends a HO Command message to the UE instructing it to move to UTRAN/HSPA for VoIMS.
8. Handover Detection at the target RNS. The UE sends an RRC message indicating the successful handover of the PS bearers to UTRAN/HSPA.
9. The Target RNS sends a Relocation Complete message to the Target SGSN.
10. Target SGSN completes the CS relocation. The following steps are performed:
 - a) Target SGSN sends a Forward Relocation Complete message to the MSC Server. MSC Server acknowledges the information by sending a Forward Relocation Complete Acknowledge message to the source SGSN.
 - b) MSC Server sends a Handover Complete message to the source MSC.
11. In parallel to the previous step the target SGSN completes the PS relocation. The following steps are performed:
 - a) Target SGSN exchanges Forward Relocation Complete / Acknowledge messages with the source SGSN.
 - b) Target SGSN performs the Update bearer procedure with the Serving GW and the PDN GW. At this point the relocation of all non-voice PS bearers is completed and the user data are flowing across UTRAN access in both directions.
12. UE performs a RAU procedure if required (e.g. due to UE mobility under CS coverage).
13. UE initiates the Session Transfer procedure e.g. by sending a SIP INVITE (STI) message to the SCC AS. Standard IMS Service Continuity procedures are applied for execution of the Session Transfer, see TS 23.292 [3] and TS 23.237 [4]. As part of this procedure the remote end is updated with the SDP of the IMS access leg. The downlink flow of VoIP packets is switched towards the PDN GW at this point. This step can occur in parallel with step 12.
14. The IMS triggers a network-initiated dedicated bearer for the voice component.
15. The IMS releases the CS access leg which result in release of resources in the MSC Server.

6.2 Solution 2: Session transfer initiated on E-UTRAN/HSPA

6.2.0 General

This solution reuses the proposal from Solution 1 with simplification to CS HO procedure.

6.2.1 Functional Description

A prerequisite for calls to be possible to handover from UTRAN/GERAN to E-UTRAN/HSPA is that they have been anchored in IMS at the time of their establishment. For calls established on the UTRAN/GERAN side with no Voice over IMS support, that implies some ICS capabilities in the network or in the UE.

Editor's Note: The functional description of the MSC enhanced for rSRVCC and of the UE enhanced for rSRVCC need to be added to this section.

6.2.2 Information flows

6.2.2.1 GERAN/UTRAN Attach procedure

The UTRAN/GERAN Attach procedure for an SRVCC from UTRAN/GERAN to E-UTRAN capable UE is performed as defined in TS 23.060 [6] with the following additions:

- 1) The UE indicates to the network its capability to perform SRVCC from UTRAN/GERAN to E-UTRAN as follows:
 - a) In case of a network of Network Mode of Operation type I:
 - The "rSRVCC capability indication" is sent by the UE in the Attach Request message sent to the SGSN at combined GPRS/IMSI Attach, and in the Routing Area Update Request message at combined RA/LA Update.
 - If received by the SGSN, the "rSRVCC capability indication" is transmitted by the SGSN to the MSC in the Location Updating Procedure.
 - b) In case of a network of Network Mode of Operation types II or III:
 - The "rSRVCC capability indication" is sent by the UE in the Location Updating Request it sends to the network.
- 2) If the subscriber is allowed to have rSRVCC in the VPLMN, the HSS shall include the "rSRVCC allowed" indication in the Insert Subscriber Data sent to the MSC at Attach or at Location Area Update.

Editor's Note: Whether a new "rSRVCC allowed" indication is required remains to be confirmed. If the information elements already defined for SRVCC are enough the parts related to that indication in this chapter and in the following ones need to be revisited.

6.2.2.2 E-UTRAN attach procedure

The E-UTRAN attach procedure for 3GPP rSRVCC UE is performed as defined in TS 23.216 [7] with the following additions:

- 1) rSRVCC UE includes the "rSRVCC capability indication" as part of the "MS Network Capability" in the Attach Request message and in Tracking Area Updates.
- 2) If the subscriber is allowed to have rSRVCC in the VPLMN, the HSS shall include the "rSRVCC allowed" indication as part of the subscription data sent to the MME.

6.2.2.3 Call establishment procedure in GERAN/UTRAN

In case the MSC server enhanced for rSRVCC determines that rSRVCC is allowed for a given call, it shall include an "rSRVCC possible indication" to the RNS/BSS at call set up to/from an rSRVCC capable UE in:

- 1) The RAB Assignment Message sent over the Iu-CS interface for a network in Iu mode.
- 2) The Assignment Request sent over the A interface for a network in A/Gb mode.

The setting of the "rSRVCC possible indication" by the MSC shall at least take into account the following elements:

- 1) rSRVCC capability of the UE

The "rSRVCC capability indication" is received from the GERAN/UTRAN to E-UTRAN SRVCC capable UE at Attach or Location Area Update, see clause 6.1.2.1.

2) Authorization of the user for rSRVCC

The "rSRVCC allowed" information is received from the GERAN/UTRAN to E-UTRAN SRVCC capable UE at Attach or Location Area Update, see clause 6.1.2.1.

3) Prior anchoring of a voice call in the SCC AS

At call establishment, the rSRVCC capable MSC server shall consider the call as anchored in the SCC AS in the two following cases:

- a) The voice call was initiated by the UE on UTRAN/GERAN using CS domain procedures and the MSC has itself anchored using ICS procedures (which can only be the case if the MSC is enhanced for ICS).
- b) The voice call was initiated on GERAN/UTRAN by a UE enhanced for ICS, using the Gm or the I1 interface for service control purposes.

To enable the MSC enhanced for rSRVCC to distinguish such calls, rSRVCC capable UEs which are also ICS capable (as defined in TS 23.292 [3]) shall include an "IMS anchoring performed" indicator in a CS CALL SETUP message corresponding to bearer control signalling for a call established using Gm or I1. The presence of that indicator shall be understood by the MSC enhanced for rSRVCC as the fact that the UE has anchored the call in IMS using ICS capabilities.

4) IMS registration status of the UE

Editor's Note: The IMS registration of the UE is implicitly signalled by the ICS UE enhanced for rSRVCC through the "IMS anchoring performed" indication included in the CS call setup message. How the MSC enhanced for ICS gets the IMS registration status of the UE is FFS.

Editor's Note: How to handle IMS registration expiration during a call is FFS.

Additionally, operator policies or local policies could be used for the MSC enhanced for rSRVCC in setting the "rSRVCC possible indication" sent towards the RNS/BSS at call establishment.

The BSS/RNS shall use that indication to decide for which cells the UE shall report measurements, as a basis for triggering a SRVCC handover from GERAN/UTRAN to E-UTRAN/HSPA.

6.2.2.4 SRVCC from E-UTRAN/HSPA to GERAN/UTRAN

The procedures defined in clauses 6.2 and 6.3 of TS 23.216 [7] apply with the following additions:

If received from the UE and the HSS respectively, the MME/SGSN shall include the "rSRVCC capability indication" as well as the "rSRVCC allowed" in the SRVCC PS to CS Request it sends to the target MSC (via the MSC enhanced for SRVCC).

In case the MSC server enhanced for rSRVCC determines that rSRVCC is allowed for a given call, it shall include an "rSRVCC possible indication" to the RNS/BSS in the Handover Request/Iu Relocation Request it sends towards the BSS/RNS.

6.2.2.5 Handover procedure in GERAN/UTRAN

If the CS domain call is subject to radio-level handover (e.g. intra-RAT, inter-RAT, intra-MSC, inter-MSC, etc) while remaining in the CS domain, the "rSRVCC possible indication" needs to be forwarded to the target radio access (RNS/BSS) provided that it still applies.

Editor's Note: The way this information is conveyed needs to be further detailed.

6.2.2.6 Call flows for SRVCC from UTRAN/GERAN to E-UTRAN

6.2.2.6.1 SRVCC handover from GERAN without DTM support to E-UTRAN

Depicted in Figure 6.2.2.1-1 is a call flow for SRVCC handover from GERAN without DTM support to E-UTRAN.

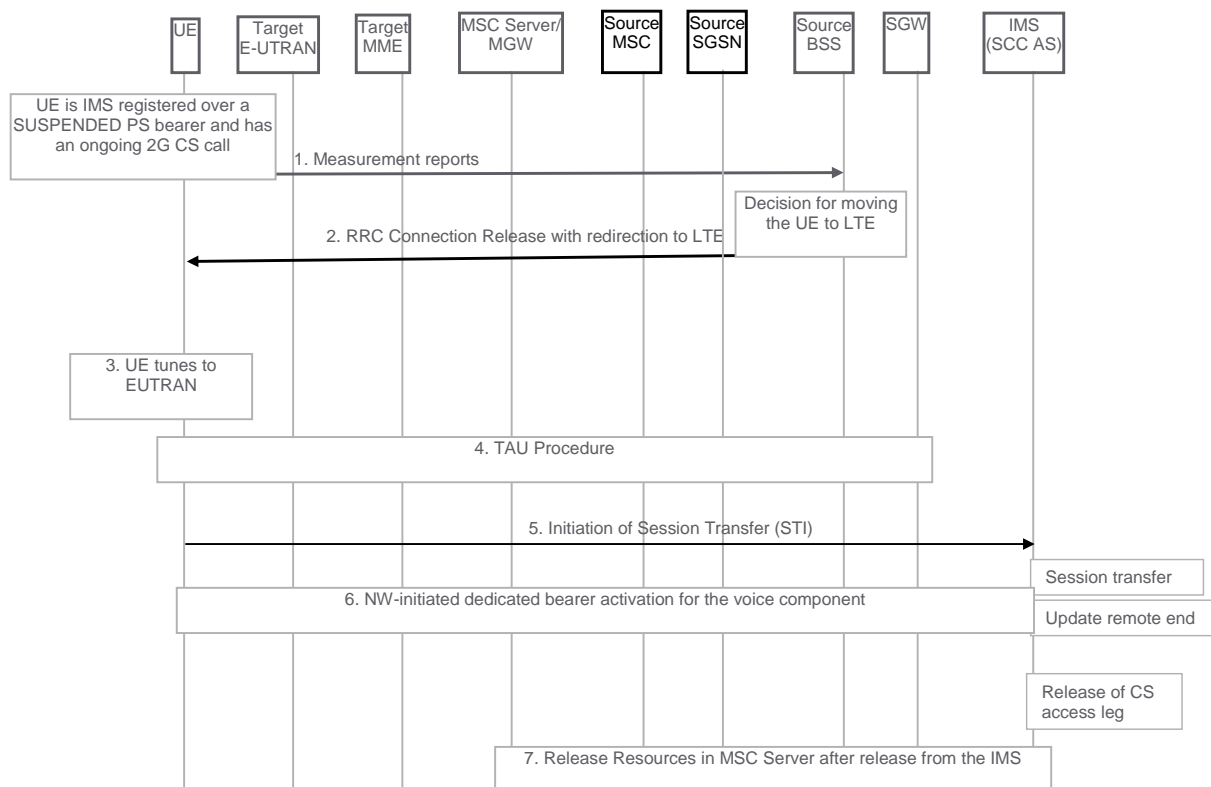

Figure 6.2.2.6.1-1: SRVCC handover from GERAN without DTM support to E-UTRAN

At the beginning of the call flow the UE is IMS registered and all PS bearers are suspended. The source system is configured to know that the target MME/TA where the UE is moving support IMS VoIP.

1. Based on UE measurement reports the source BSS decides to move this UE to E-UTRAN.

Editor's Note: How BSS determine this UE can be redirected to E-UTRAN is FFS!

2. Source BSS triggers RRC connection release with redirection to E-UTRAN for rSRVCC
- 3-4. UE re-tunes to E-UTRAN radio and performs a TAU procedure as specified in TS 23.401 [5]. UE uses the Active flag in the TAU Request to MME to resume the suspended SIP signalling bearer and any other suspended non-voice bearers. The MME requests the context from the source SGSN. The MME will inform S-GW and PDN-GW(s) to resume the suspended bearers
5. Subsequently UE initiates the Session Transfer procedure e.g. by sending a SIP INVITE (STI) message to the SCC AS. Standard IMS Service Continuity procedures are applied for execution of the Session Transfer, see TS 23.237 [4]. As part of this procedure the remote end is updated with the SDP of the IMS access leg. The downlink flow of VoIP packets is switched towards the PDN GW at this point.
6. The IMS triggers a network-initiated dedicated bearer activation for the voice component.
7. The IMS releases the CS access leg which result in release of resources in the MSC Server.

6.2.2.6.2 SRVCC handover from UTRAN or GERAN with PS handover support to E-UTRAN

Depicted in Figure 6.2.2.2-1 is a call flow for SRVCC handover from UTRAN or GERAN with PS handover support to E-UTRAN, including the handling of the non-voice component. E-UTRAN neighbouring cells have to be configured in UTRAN/GERAN for the purpose of measurements. The source system is configured to know that the target MME/TA where the UE is moving support IMS VoIP.

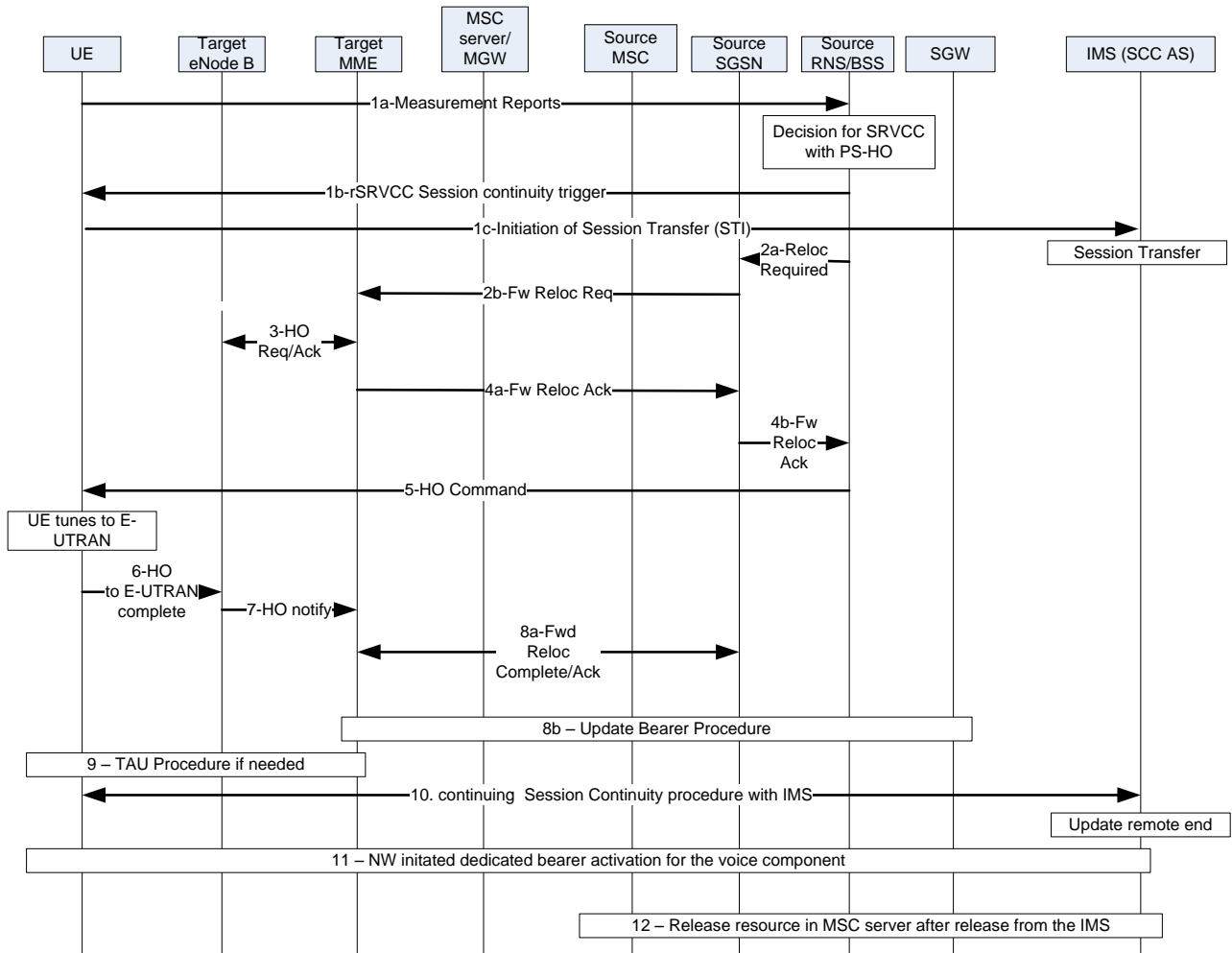

Figure 6.2.2.6.2-1: SRVCC handover from UTRAN or GERAN with PS handover support to E-UTRAN

Editor's Note: How to ensure the voice bearer switching only occur after the UE has gone to the target side is FFS.

- 1a. Based on UE measurement reports the RNS/BSS decides to trigger a SRVCC and PS handover to E-UTRAN.
- 1b. Since PS bearer is active; BSS/RNS sends an indication to UE to start session transfer procedure.
- 1c. UE starts the session transfer procedure with STI to IMS
2. Source RNS initiates PS relocation. The following steps are performed:
 - a) Source RNS/BSS sends a Relocation Required (Source to Target Transparent Container) message to source SGSN.
 - b) Source SGSN sends a Forward Relocation Request message to the target MME including information about the non-voice component only.
3. Target MME handles the Forward Relocation Request messages and requests resource allocation for the non-voice component only by exchanging Handover Request/Acknowledge messages with the target E-UTRAN.

4. The target MME acknowledges the prepared PS relocation towards the source access. The following steps are performed:
 - a) Target MME sends a Forward Relocation Response (Target to Source Transparent Container) message to the source SGSN.
 - b) Source SGSN sends a Relocation Required Acknowledge (Target to Source Transparent Container) message to the source RNS/BSS.
5. Source RNS/BSS receives the Relocation Required Acknowledge message for the PS HO and sends a HO Command message to the UE instructing it to perform a handover to E-UTRAN.
6. UE re-tunes to E-UTRAN radio and sends a Handover to E-UTRAN Complete message to the E-UTRAN.
7. Target E-UTRAN informs the target MME by sending a Handover Notify message.
8. The target MME completes the PS relocation. The following steps are performed:
 - a) Target MME exchanges Forward Relocation Complete / Acknowledge messages with the source SGSN.
 - b) Target MME performs the Update bearer procedure with the Serving GW and the PDN GW. At this point the relocation of all non-voice PS bearers is completed and the user data are flowing across E-UTRAN access in both directions.
9. UE performs a TAU procedure if required (e.g. due to UE mobility under CS coverage).
10. UE continues the Session Transfer procedure which was started at the source side with SCC AS. As part of this procedure the remote end is updated with the SDP of the IMS access leg. The downlink flow of VoIP packets is switched towards the PDN GW at this point. This step can occur in parallel with step 9.
11. The IMS triggers a network-initiated dedicated bearer for the voice component.
12. The IMS releases the CS access leg which result in release of resources in the MSC Server.

6.3 Solution 3+5: Media anchoring in serving network with Access Transfer Control Functionality

6.3.1 Architecture Reference Model

The architecture is in accordance to SRVCC using ATCF enhancements as specified in TS 23.237 [4]. The source MSC Server is assumed to be enhanced for rSRVCC.

Figure 6.3.1-1 provides a further clarification of the reference architecture for rSRVCC. The figure only depicts the specific reference points for reverse SRVCC.

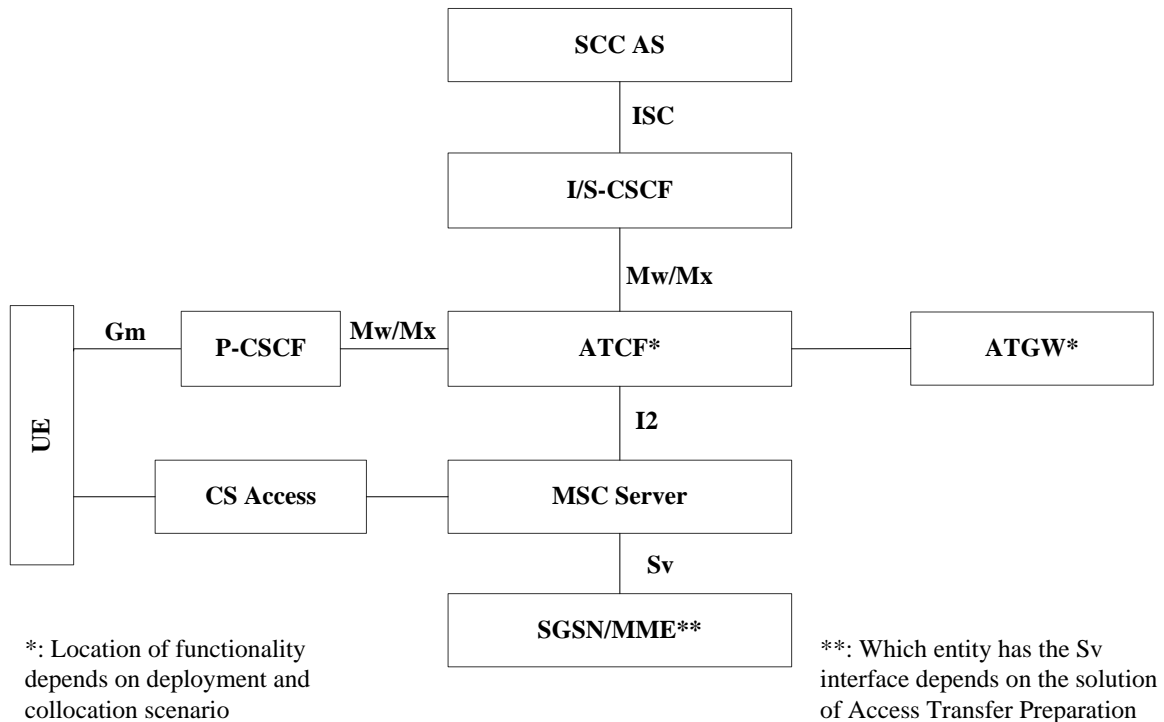

Figure 6.3.1-1: Reference Architecture for reverse SRVCC.

NOTE 1: MSC Server and SGSN/MME shown in the figure are enhanced for reverse SRVCC. Whether SGSN, or MME, or both are enhanced depends on sub-alternatives.

Depending on the alternative chosen for the access transfer preparation, some of the elements shown in the figure might not be impacted, see clause 6.3.2.

No matter which alternative is chosen for the access transfer preparation, the solution proposed here does not require all MSCs in the operator's network to be upgraded for rSRVCC. Only the ones controlling location areas close to E-UTRAN/HSPA tracking / routing areas with VoIMS support would need to be upgraded.

NOTE 2: CS calls started in location areas that are controlled by an MSC not supporting rSRVCC can not be transferred to E-UTRAN.

For access transfer preparation alternatives 1 and 2, only the source SGSNs covering cells close to E-UTRAN/HSPA cells with VoIMS support would need to be upgraded.

For access transfer preparation alternative 3, all source SGSNs in the operator's network would need to be upgraded.

6.3.2 Functional Entities

6.3.2.1 ATCF

The ATCF shall be based on the functionality specified in TS 23.237 [4], with the following enhancements:

- At registration from MSC Server enhanced for rSRVCC, the ATCF includes itself to the path for future session establishments over CS and correlates the registration with the related PS registration.
- Make media anchoring decision with additional criteria of UE's reverse SRVCC capability for session setups initiated from/m/destined to the MSC Server enhanced for rSRVCC;
- Correlate the Session Transfer procedures initiated by the UE and the MSC Server enhanced for rSRVCC.
- If media anchoring has been made at session establishment, perform the Access Transfer and update the ATGW with the new media path for the new (PS) access leg, without requiring updating the remote leg;
- If media anchoring has not been made at session establishment,

- Optionally anchor the call in the ATGW as part of the rSRVCC procedure by establishing the new media path between MGW and ATGW for the new (PS) access leg,
- And updating the remote leg once the UE is on the target access and performs the service continuity procedure;

Editor's Note 2: If the call (voice media) is not anchored in the ATGW, executing the remote leg update procedure following rSRVCC handover is required, and whether or not the performance of rSRVCC will then be acceptable is FFS.

6.3.2.2 SCC AS

The SCC AS shall be based on the functionality specified in TS 23.237 [4], with the following enhancements:

- If indicated from the MSC Server enhanced for rSRVCC, the SCC AS shall notify the MSC Server enhanced for rSRVCC of the STN-SR of the ATCF when changes to this occur (i.e., during an initial IMS registration from the UE over PS access).

6.3.2.3 P-CSCF

- If access transfer preparation alternatives 1 and 3: The P-CSCF may interact with PCRF for the preparation of the Access Transfer if informed by the ATCF.

6.3.2.4 MSC Server enhanced for reverse SRVCC

The MSC Server enhanced for reverse SRVCC shall be based on the functionality specified in TS 23.216 [7], TS 23.292 [3], and TS 23.237 [4], with the following enhancements:

- If an ATCF was allocated at IMS registration from the UE and decided to remain in the session paths:
 - Discover the ATCF address if not already available.
 - Using the ATCF as outgoing proxy when performing IMS registration.
- If access transfer preparation alternative 1: Initiate the session transfer procedure from CS to IMS;
- Initiating the CS to PS handover procedure for handover of the voice component to the target cell via the Sv interface.

It is assumed the MSC Server supports the I2 reference point, and is capable of registering on behalf of the user to the IMS as specified in TS 23.292 [3].

6.3.2.5 SGSN enhanced for rSRVCC

The source SGSN shall:

- If access transfer preparation alternatives 1 and 2: Handle the Relocation Preparation procedure requested from MSC Server enhanced for rSRVCC via Sv reference point;
- If access transfer preparation alternative 2: Perform the bearer reservation procedure for voice media in target access;
- If access transfer preparation alternative 3: Establish voice bearer without allocating radio resources for it;
- If access transfer preparation alternatives 1 and 2: Coordinating PS handover and CS to PS handover procedures when both procedures are performed.

6.3.2.6 UE enhanced for rSRVCC

The rSRVCC UE shall:

- Indicate to the access network and IMS that the UE is rSRVCC capable.

- Pre-allocate ports to be used for voice after an rSRVCC handover and inform the network about them OR use pre-defined ports after such a handover
- Inform the network about supported Codecs that could be used for voice after rSRVCC handover OR use a pre-defined codec for voice after such a handover.
- If access transfer preparation alternatives 1 and 2: receive information about the voice bearer as part of the handover procedure and start using it as soon as going over to the target access.
- If access transfer preparation alternative 3: Trigger the establishment of a voice bearer to be used after rSRVCC handover after performing IMS registration.
- Re-establish the session control of the media after handover to the target access.

6.3.2.7 HSS

The HSS shall be based on the functionality specified in TS 23.237 [4], with the following enhancements:

- Include a rSRVCC allowed indication as part of the subscriber data.

6.3.2.8 MME/SGSN enhanced for rSRVCC

- If handover preparation alternative 4: Handle the Relocation Preparation procedure requested from MSC Server enhanced for rSRVCC via Sv reference point;
- If handover preparation alternative 4: Retrieve PDP context related information from the source SGSN if PS-PS handover is not performed at the same time as a rSRVCC handover.
- If handover preparation alternative 4: Perform the bearer reservation procedure for voice media in target access;

6.3.3 Message Flows

6.3.3.1 General principles

This solution has the following characteristics:

- It is assumed the MSC Server is enhanced for ICS and has an I2 interface to be able to register on behalf of the UE.
- The source RAN is capable of including E-UTRAN cells with VoIP capability into the neighbour cell list.
- The architecture reuses the eSRVCC architecture, i.e. SRVCC with ATCF enhancements.
- It is assumed that the MSC Server obtains the address of the ATCF prior registration through the ATCF.
- rSRVCC will be used for a UE if the UE is rSRVCC capable, the rSRVCC allowed indication was part of the subscriber data received from HSS, and the UE is IMS registered.
- When registering to IMS on behalf of the UE, the MSC Server will register through the ATCF if rSRVCC can be used for the UE (i.e., UE is rSRVCC capable and the subscriber has the rSRVCC allowed indication set) and if an ATCF was allocated and decided to remain in the session paths of the UE when it registered over IMS.
- If rSRVCC can be used for the UE, originating and terminating calls established over CS are routed through the ATCF as per existing IMS procedures if an ATCF was involved at registration time. The ATCF then decides whether to anchor the media or not in the ATGW.
- At a high level, the rSRVCC handover procedure is based on the following steps:
 - 1) The PS bearer for the active voice session is established in the PS core network before sending the UE to the target access.
 - 2) The media plane for the active voice call is switched to the target access while the UE is instructed to move to the target access, so the UE is able to receive/transmit voice as soon as it has tuned to the target access.

- 3) The control plane and the media for the held calls are switched by the UE after tuning to the target access.

A prerequisite for the flows is that the user is registered in IMS and has at least one PS bearer (used for SIP signalling).

6.3.3.2 GERAN/UTRAN Attach procedure

The UTRAN/GERAN Attach procedure for an rSRVCC capable UE is performed as defined in TS 23.060 [6] with the following additions:

- The UE indicates to the network its capability to perform rSRVCC as follows:
 - In case of a network of Network Mode of Operation type I:
 - The "rSRVCC capability indication" is sent by the UE in the Attach Request message to the SGSN at combined GPRS/IMSI Attach, and in the Routing Area Update Request message at combined RA/LA Update.
 - If received by the SGSN, the "rSRVCC capability indication" is sent to the MSC in the Location Updating Procedure.
 - In case of a network of Network Mode of Operation types II or III:
 - The "rSRVCC capability indication" is sent by the UE in the Attach Request message sent to the MSC.
- If the subscriber is allowed to have rSRVCC in the VPLMN, the HSS shall include the "rSRVCC allowed" indication in the Insert Subscriber Data sent to the MSC Server.

6.3.3.3 E-UTRAN attach procedure

The E-UTRAN attach procedure for 3GPP rSRVCC UE is performed as defined in TS 23.216 [7] with the following addition:

- rSRVCC UE includes the "rSRVCC capability indication" as part of the "MS Network Capability" in the Attach Request message and in Tracking Area Updates.
- If the subscriber is allowed to have rSRVCC in the VPLMN, the HSS shall include the "rSRVCC allowed" indication as part of the subscription data sent to the MME.

6.3.3.3a Informing the source RAN about the possibility to perform rSRVCC

The MSC Server determines the possibility of performing rSRVCC based on:

- The rSRVCC capability of the UE.
- The presence of the rSRVCC allowed indication in the subscription data of the user.
- The IMS registration status of the UE (i.e., if the MSC Server has registered through the ATCF).
- For access transfer preparation alternatives 1 and 2: the rSRVCC capability of the SGSN the UE is currently registered.

The MSC Server informs the RAN about the possibility to perform rSRVCC by sending an "rSRVCC operation possible" to the RNC/BSC:

- in the case of the Iu-CS interface: the Common ID message when the Iu Connection is setup between the MSC Server and the RNC/BSC at Attach Request, Location Area Update, at SRNS relocation, at inter-RAT handover from GERAN,
- in the case of the A interface: in the appropriate message(s) to be defined at stage 3 at attach request, location area update, at intra and inter-MSC handover, at inter-RAT handover from UTRAN.

In case of inter-MSC handover, the rSRVCC operation possible indication shall be conveyed in the prepare HO required message sent from the anchor MSC to the target MSC.

The RAN shall use that information for deciding the cells for which the UE shall report measurements that lead to handover request to the core network.

6.3.3.4 Codec and transport address related procedure

6.3.3.4.1 General

For rSRVCC to work, the network needs to know the following information about the UE:

- the IP address and port number used by the UE for receiving voice media on PS access,
- identifier of the new SGSN / old MME.

The UE needs to reserve a port for rSRVCC. The UE needs to know the IP address, port number and codec for sending media to the ATGW (in case of media anchoring) or the remote end (in case no media anchoring took place).

NOTE: Depending on the alternative for access transfer preparation, different network elements that need to have that information: the ATCF (alternative 1), the MSC (alternative 2), the source SGSN / old MME (alternative 3), and the target MME (alternative 4).

6.3.3.4.2 Information in IMS registration and handover procedure

For access transfer preparation alternatives 1 and 2: The IP address of the UE is assigned by the network. When registering in the IMS, the UE can indicate its IP address, port and default codec (or list of supported codecs) it will receive media on when a transfer is performed. The MSC Server or ATCF can learn this information and if needed the address of the P-CSCF from the IMS (e.g. during IMS registration or using an event package).

For access transfer preparation alternative 3 and 4: the codec, IP address and ports are sent from the UE to the network in the post registration IMS signaling used to pre-establish a PS voice bearer.

6.3.3.5 Establish a session over CS

6.3.3.5.1 STN-SR allocated by the ATCF and Transfer Info sent to ATCF

When the UE performs IMS registration, the request is routed through the ATCF, since it is assumed that that ATCF is co-located with a node processing the IMS registration in the serving network, roaming if not home. The ATCF may decide to be involved in the session establishments made over IMS or not at that point, as described in TS 23.216 [7]. In case it does, and if the MSC Server (according to TS 23.292 [3], clause 7.2.1) registered the user in the IMS based on the CS attach before the UE has performed IMS registration, the MSC Server will not have the address of the ATCF when the IMS registration is performed. Therefore it is proposed to proceed as follows:

- 1) The MSC Server performs IMS Registration according to TS 23.292 [3], clause 7.2.1 and indicates to the SCC AS that it wishes to be informed about STN-SR allocated by the ATCF in case of user registration over PS.
- 2) The UE performs IMS registration via Gm. ATCF is allocated and SCC AS is informed if the ATCF wishes to remain in the path of future session establishments (which is the case assumed in the following steps).
- 3) The SCC AS, when receiving 3rd party registration from the UE including dynamically allocated STN-SR from the ATCF and having received the indication of interest in the STN-SR by the MSC Server informs MSC Server about allocated ATCF. In the case of access transfer preparation alternative #2, the SCC AS also indicates to the MSC the IP address of the UE, the ports allocated by it, and the codecs it supports.
- 4) When receiving a new STN-SR from the SCC AS, the MSC Server performs re-registration towards the allocated ATCF (see clause 6.3.3.5.2).

If the ATCF involves in the session made over IMS, the procedure of SCC AS providing C-MSISDN and ATU-STI to ATCF as specified in clause 6.3.1.7 of TS 23.237 [4] shall be applied.

The dynamic STI-rSR shall be provided to the UE from the ATCF. It is left for stage 3 to decide on appropriate mean to provide the dynamic STI-rSR to the UE.

6.3.3.5.2 Registration when ATCF involved

The CS registration is done according to TS 23.292 [3] clause 7.2.1, with the difference that the registration is routed through the ATCF.

The scenario where the ATCF is involved in the registration path, and decides to include itself for the duration of the registration is shown in figure 6.3.3.5.2-1 below.

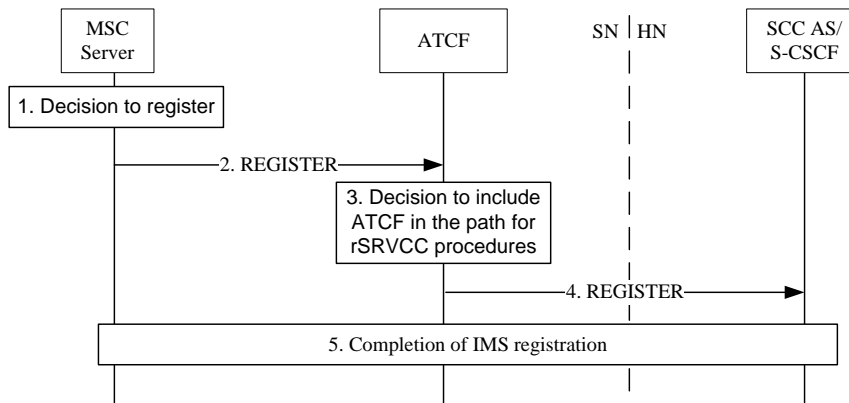

Figure 6.3.3.5.2-1: Registration from CS through ATCF

1. The MSC Server decides to register the UE through CS according to TS 23.292 [3].
2. If rSRVCC can be used for the UE and if an ATCF has decided to remain in the path of session establishments when the UE registered over IMS, the MSC Server sends the REGISTER to the IMS through the ATCF (using the STN-SR that identifies the ATCF).
3. The ATCF detects that the Register is received from the MSC Server and decides to include itself for the session by adding itself in the route path.
4. The Register is forwarded towards the registrar according to TS 23.292 [3].
5. The registration process is completed.

When the ATCF involves in the session made over IMS, the procedure of SCC AS providing C-MSISDN and ATU-STI to ATCF as specified in clause 6.3.1.7 of TS 23.237 [4] shall be applied also for the MSC Server registration.

6.3.3.5.3 Origination procedures when ATCF involved

The CS origination is done according to TS 23.292 [3], clause 7.3, with the difference that the call is routed through the ATCF (that was added to the call path during registration according to clause 6.3.3.5.2).

NOTE: The call may also have been transferred to CS by an SRVCC PS to CS access transfer procedure.

The scenario where the ATCF is involved in the call set up, and decides to anchor the media in the ATGW is shown in figure 6.3.3.5.3-1 below.

Once the session is established, the ATCF will act as the access transfer function in the call.

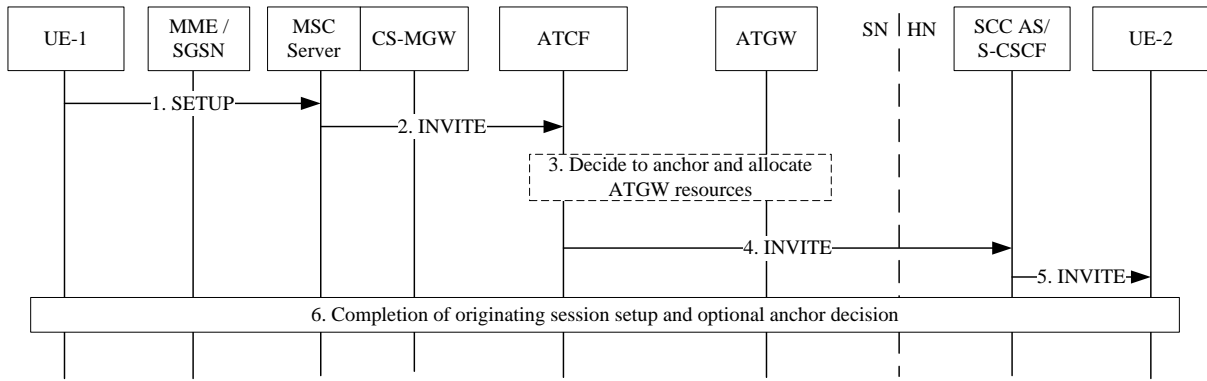

Figure 6.3.3.5.3-1: Originating call setup over CS through ATCF

1. The MSC Server receives the CS setup message.
2. The MSC Server initiates an INVITE origination according to TS 23.292 [3] clause 7.3. As the ATCF is in the route, the MSC server, forwards the INVITE to the ATCF.
3. The ATCF may decide whether to anchor the media session and allocate if needed ATGW resources to it. Anchoring criteria used could be same as for eSRVCC (see TS 23.237 [4]).
- 4-5. The call setup proceeds and is routed to the remote UE-2.
6. The call setup is completed.

6.3.3.5.4 Termination procedures when ATCF involved

The CS termination is done according to TS 23.292 [3] clause 7.4, with the difference that the call is routed through the ATCF (that was added to the call path during registration according to clause 6.3.3.5.2).

NOTE: The call may also have ended up in CS by an SRVCC PS to CS access transfer procedure.

The scenario where the ATCF is involved in the call set up, and decides to anchor the media in the ATGW is shown in figure 6.3.3.5.4-1 below.

Once the session is established, the ATCF will act as the access transfer function in the call.

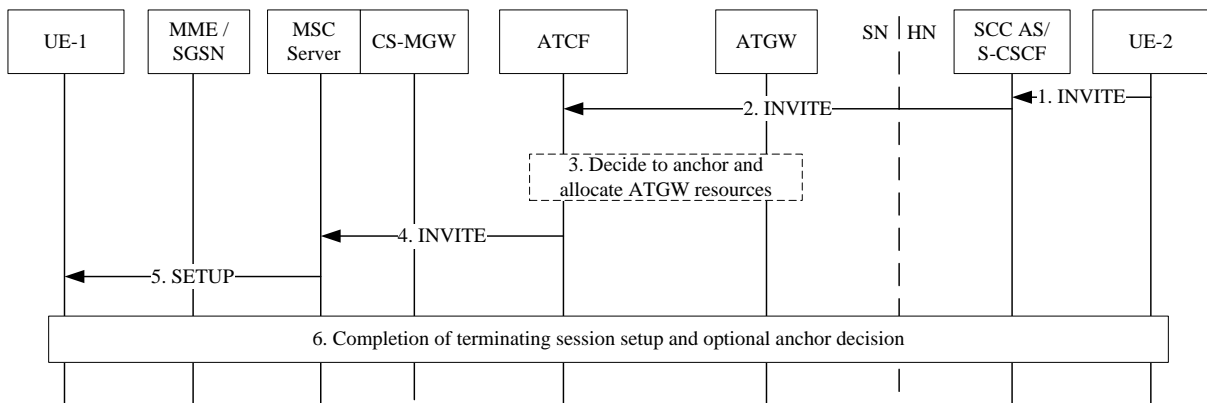

Figure 6.3.3.5.4-1: Terminating call setup over CS through ATCF

- 1-2. UE-2 sends an INVITE towards UE-2. The call is routed towards UE-1 via ATCF as the ATCF was added in the route during registration.
3. The ATCF may decide whether to anchor the media session and allocate if needed ATGW resources to it. Anchoring criteria used could be same as for eSRVCC (see TS 23.237 [4]).
- 4-5. The call setup proceeds and is routed toward UE-1 according to TS 23.292 [3].

6. The call setup is completed.

6.3.3.6 CS – PS Access Transfer Overview

6.3.3.6.1 Anchored in ATGW

This clause describes the main steps of the rSRVCC procedure when using ATCF enhancements.

The following flow assumes that the UE has indicated to both MSC and SGSN that it is rSRVCC capable.

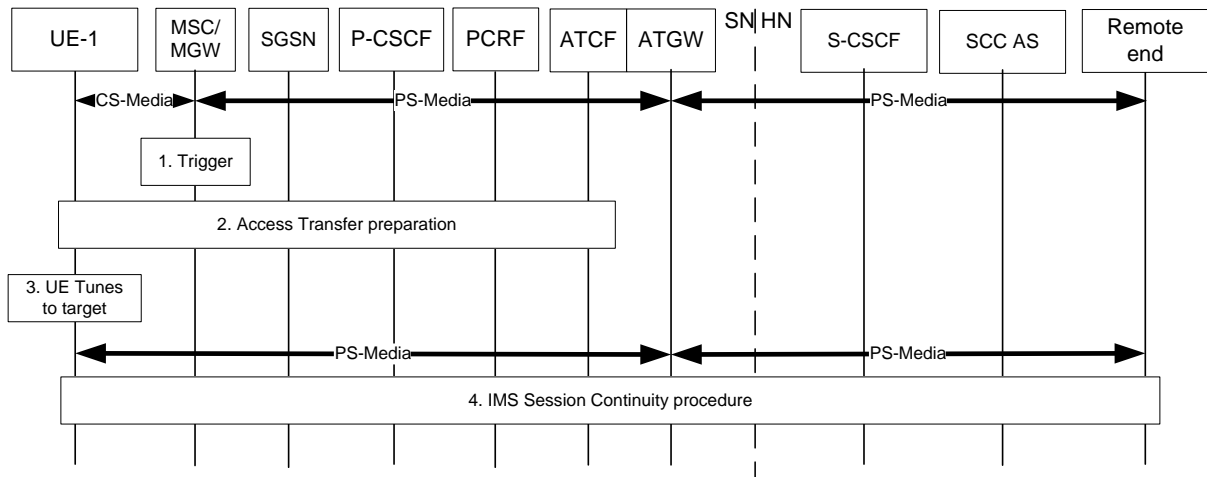

Figure 6.3.3.6.1-1: CS-PS Access Transfer – with media anchored in ATGW

The media paths shown in the figure assume that the media has been anchored in the ATGW at call set up.

1. The MSC Server receives the trigger to initiate the access transfer.
2. Access Transfer preparation: This step is further detailed below in clause 6.3.3.7.
3. UE tunes to target radio access. UE sends and receives voice media over PS.
4. The access transfer is completed by moving the session control to the PS access leg. This step is further detailed below in clause 6.3.3.8.

NOTE: After step 4, the media path is between the UE via EPC to the ATGW.

6.3.3.6.2 Not Anchored in ATGW

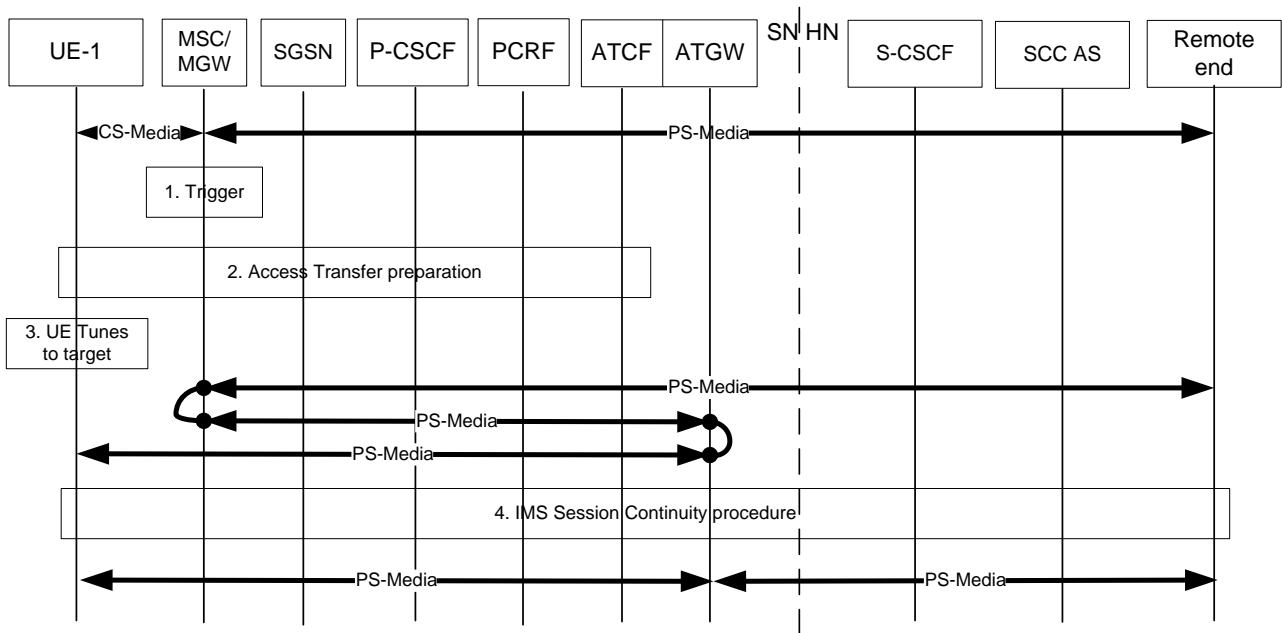

Figure 6.3.3.6.2-1: CS-PS Access Transfer –without media anchored in ATGW

The media paths shown in the figure assume that the media has not been anchored in the ATGW at call set up.

1. The MSC Server receives the trigger to initiate the access transfer.
2. Access Transfer preparation: This step is further detailed below in clause 6.3.3.7.
3. UE tunes to target radio access. UE sends and receives voice media over PS.
4. The access transfer is completed by moving the session control to the PS access leg. This step is further detailed below in clause 6.3.3.8.

6.3.3.7 Access Transfer Preparation

6.3.3.7.1 Access Transfer Preparation Alternative 1

The more detailed procedures of the Access Transfer Preparation step are shown in the following figure. In this alternative, the source MSC Server together with the ATCF interacts with the P-CSCF to initiate the voice bearer setup. The address of the P-CSCF is known to the ATCF from the IMS registration of the UE, and the ATCF address is known to the MSC Server from the STN-SR. It is also assumed that PCC is used.

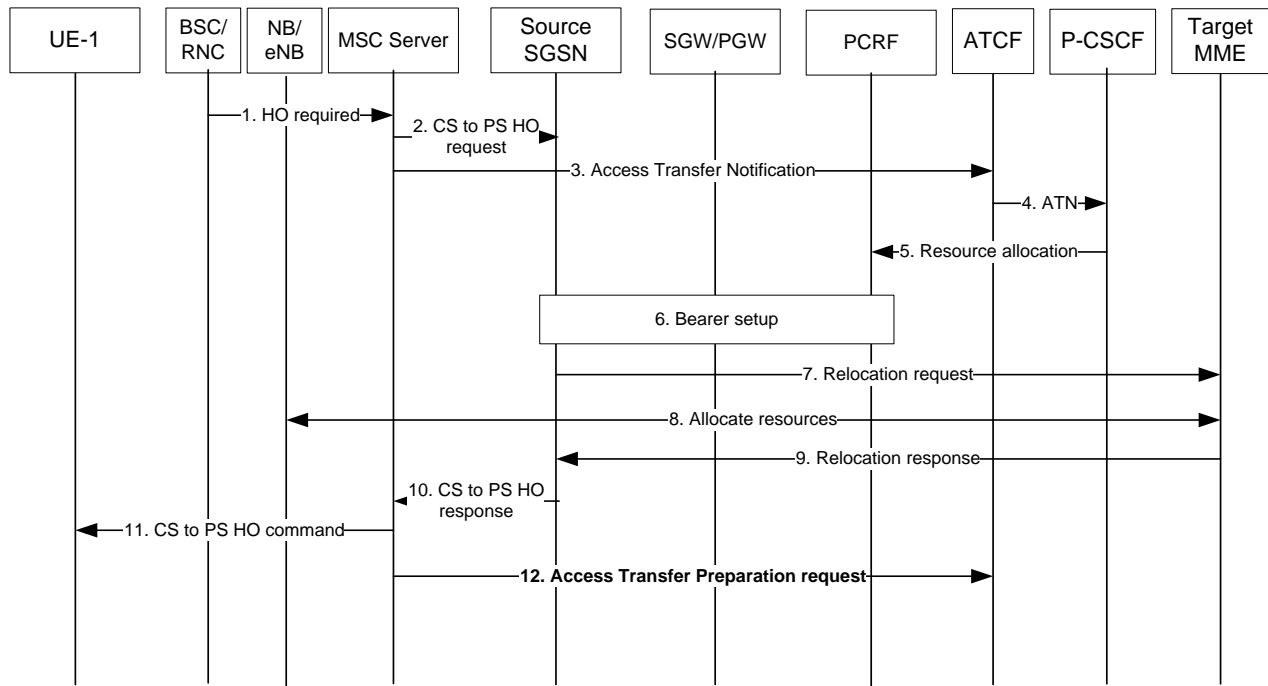

Figure 6.3.3.7.1-1: Access Transfer Preparation Alternative 1

1. The RNC/BSC sends a HO required to the MSC Server including an indication this HO is for SRVCC. If the MSC Server is the target MSC, it forwards the HO required to the anchor MSC Server.

NOTE 1: If the UE is active in PS domain, the RNC/BSC sends also a Relocation Required message to source SGSN. If the Relocation Required message for PS HO arrives first and the message indicates CS to PS HO is initiated, the source SGSN waits for the CS to PS HO request before performing inter-RAT handover procedure.

2. The MSC Server sends a SRVCC CS to PS HO command to the Source SGSN / old MME. The IMSI should be included in the message to allow the source SGSN/MME to identify UE.
3. The MSC Server sends an Access Transfer Notification to the ATCF, e.g. a SIP re-INVITE or INVITE message, which indicates the ATCF that it should prepare for the transfer of media to PS.
4. The ATCF retrieves the ports/codecs received from the UE in its IMS registration (The MSC is able to correlate the IMS registration made by the UE and the one made by the MSC on behalf of the UE for instance based on the C-MSISDN or on the IMEI derived instance-id used by both those registrations). The ATCF allocates media ports on the ATGW, then forwards the Transfer Preparation Request to the P-CSCF after including in that message the IP address/ports the UE intends to use after rSRVCC, as well as the IP address/ports the ATGW is sending voice media to (i.e. the SDP for both UE and ATGW will be included in the message).
5. The P-CSCF interacts with the PCRF to establish a voice bearer for the session being transferred using the information received from the ATCF in the Transfer Preparation Request message. The PCC indicates that this bearer establishment is due to rSRVCC.

NOTE 2: The Transfer Preparation Request message could e.g., be implemented using a INVITE or other appropriate message. It is left for stage 3 to decide on appropriate message.

6. The PCRF initiates the bearer setup towards P-GW and indicates that this bearer establishment is due to rSRVCC. Once the bearer setup reaches source SGSN / old MME, the SGSN / MME associates the new bearer with the HO CS to PS request that was received previously. The source SGSN / old MME will handle the bearer setup locally, without requiring a full reservation at the source side of the voice bearer.

NOTE 3: If ISR is activated and the Serving GW does not have a downlink S1-U, the Serving GW sends Downlink Data Notification to the MME and the SGSN before sending the Update Bearer Request message with an indication that this is due to rSRVCC. The serving PS node that received the CS to PS HO request from the MSC will then answer to it with a Modify Bearer Request, without paging the UE. The SGW will answer that message without propagating it to the PGW.

7. Source SGSN / old MME sends a relocation request to the target SGSN/MME.
8. Target SGSN/MME allocates resources in UTRAN/E-UTRAN.
9. A relocation response is returned to the Source SGSN/ old MME.
10. A SRVCC CS to PS HO response is returned from the Source SGSN/ old MME to the MSC Server. The SGSN also includes in that message the EPS bearer information.
11. MSC Server sends HO required Ack to the RAN, possibly via the target MSC, and the RAN send HO command to UE, indicating CS to PS handover. The MSC Server also includes in that message the EPS bearer information as well as the IP address/ports and selected codec for the ATGW, for the MGW or for the remote end depending on the situation.
12. In case of ATCF with media anchored in ATGW, the MSC Server sends an Access Transfer Preparation Request, e.g. a SIP re-INVITE or PRA CK message, to the ATCF to trigger the ATCF/ATGW to have the media path switched to the IP address/port of the UE on the target access.

In case of without media anchored in ATGW, MSC Server sends an Access Transfer Preparation Request to ATCF and the media path between ATCF/ATGW and the MSC Server/MGW is to be established.

Editor's Note 1: The responsibility to release the voice bearer in error cases during this procedure are FFS.

Editor's Note 2: It is FFS how to resume suspended PS bearers after UE tunes to target access, e.g. UE handover from GERAN not supporting DTM.

6.3.3.7.2 Access Transfer Preparation Alternative 2

The more detailed procedures of the Access Transfer Preparation step are shown in the following figure. In this alternative, the source SGSN initiates the voice bearer setup.

Editor's Note 1: The role of the target MSC in this solution is FFS.

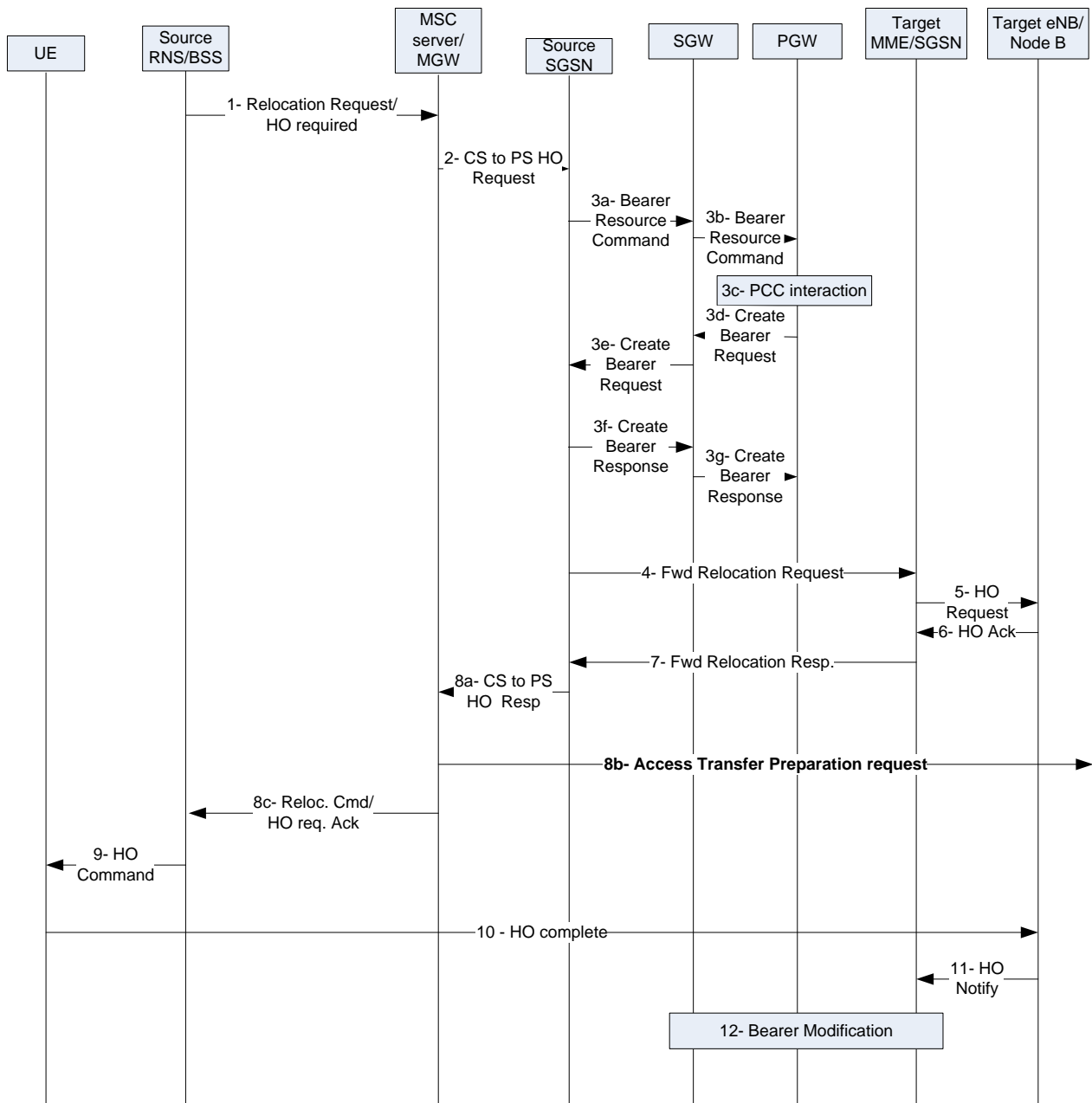

Figure 6.3.3.7.2-1: Access Transfer Preparation – Alternative 2

1. The RNS/BSS decides that an rSRVCC handover should take place. It therefore sends a Relocation Required (case of the Iu interface), or a Handover Required (in the case of the A interface) to the MSC. That message includes an indication that an rSRVCC handover is requested.
2. The MSC Server forwards the rSRVCC request to the source SGSN or the source MME according to what it stored as "serving PS node" for the UE, in a CS to PS HO Request. That message includes the transport address provided by the UE (see also clause 6.3.3.4), as well as the address it is sending voice media to (e.g. the transport address of the ATGW or of the remote end). It also includes information related to the pre-agreed codec for voice. In addition, the IMSI should be also included to allow the source SGSN/MME to identify UE.
- 3a. When receiving that message, the SGSN/MME sends a Bearer Resource Command to the SGW, to trigger the set up the PS voice bearer. The Traffic Aggregate Description (TAD) includes transport address information for both ends of the future packet voice access leg i.e. information provided by both UE and MGW. The requested QoS corresponds to the QoS of a packet voice bearer and may take into account the codec information.
- 3b. The SGW forwards the Bearer Resource Command to the PGW.
- 3c. The PGW interacts with the PCRF in case dynamic PCC is deployed.

- 3d. The PGW initiates (either based on the response of the PCRF in case of dynamic PCC, or as its own decision) the creation of the bearer, by sending a Create Bearer Request to the SGW. The message includes the essential EPS bearer information i.e. the TFT (compiled from TAD information) and the QoS of the future EPS bearer supporting packet voice on E-UTRAN side, with the exception of the EPS Bearer ID/NSAPI, which is assigned later. The message may also include the IP address assigned to the UE in order to cope with some cases when the SGSN/MME is not aware of it.
 - 3e. The SGW forwards the Create Bearer Request to the Source SGSN / Source MME. The message includes the essential EPS bearer information, with the exception of the EPS Bearer ID/NSAPI, which is assigned later. The message may also include the IP address assigned to the UE in order to cope with some cases when the SGSN is not aware of it.
 - 3f. The source SGSN / source MME assigns the EPS Bearer ID/NSAPI for the future packet voice bearer, and replies with a Create Bearer Response to the SGW. It does not request the RNS/BSS to allocate any radio resources for that bearer.
 - 3g. The SGW sends a Create Bearer Response to the PGW, which finalizes the voice bearer creation.
 4. When step 3f has occurred, the Source SGSN / source MME sends a Forward Relocation Request to the Target MME/SGSN. The message includes bearer context for all bearers, including the future packet voice bearer.
 - 5-6. The Target MME/SGSN requests the Target eNodeB/NodeB to allocate resources for all bearers (including the voice bearer). The Target eNode B/Node B answers, including the transparent container destined to the UE.
 7. The Target MME/SGSN answers to the Source SGSN / source MME, indicating that the resources have been allocated in the Target eNodeB/Node B.
 - 8a. The source SGSN / source MME answers to MSC Server in a CS to PS HO Response indicating the success of the procedure. The essential EPS bearer information the UE will use for voice after rSRVCC handover and UE's IP address is included in that message.
 - 8b. When receiving that message, in case of ATCF with media anchored in ATGW, the MSC Server sends an Access Transfer Preparation Request, e.g. a SIP re-INVITE or INVITE message, to the ATCF to have the media path switched to the transport address of the UE on the target access. That step could also occur anytime after step 2.
- In case of without media anchored in ATGW, MSC Server sends an Access Transfer Preparation Request to ATCF and the media path between ATCF / ATGW and the MSC Server / MGW is to be established.
- 8c. The MSC Server sends a Relocation Command to the Source RNS/BSS. This message also includes the EPS bearer information as well as the IP address/ports and selected codec for the ATGW, for the MGW or for the remote end depending on the situation.
 9. When receiving the Relocation Command from the MSC Server, the source BSS/RNS sends a HO Command to the UE. This message also includes the EPS bearer information as well as the IP address/ports and selected codec for the ATGW, for the MGW or for the remote end depending on the situation.
 10. The UE retunes to the target access (E-UTRAN/HSPA). The UE sets up locally a PS voice bearer using the NAS information received from the network in the HO Command of step 9. As a result of that message, the UE also resumes the other existing PS bearers in case those were suspended. The UE sends a HO Complete message to the Target eNB/Node B. It starts sending and receiving voice using the PS voice bearer.
 11. When receiving that message from the UE, the target eNode B/Node B sends a Handover Notify to the target MME/SGSN.
 12. The target MME/SGSN performs the bearer modification procedure towards the SGW/PGW, effectively completing the EPS-level handover procedure. Note that in case the PS bearers were suspended, they are resumed in the SGW/PGW as an implicit result of the bearer modification procedure.

6.3.3.7.3 Access Transfer Preparation Alternative 3

The more detailed procedures of the Access Transfer Preparation step are shown in the following figure. This alternative is based on the Alternative 1, the difference is the UE and ATCF negotiate the codec by standard SDP offer/answer procedure prior to the CS call, e.g. immediately after the IMS registration. At the same time, also the voice

media bearer (QCI=1) is reserved from the source RAT, but the media flow is not activated. For this reason, unlike in Alternative 1, the transfer preparation for the voice media bearer is not needed between MSC Server – ATCF – P-CSCF – PCRF, which makes the transfer phase less complex and speeds up the procedure. On the downside, this alternative requires more resources from the VPLMN; besides to the SIP and media resources from ATCF, also suspended QCI=1 bearer is reserved for all UEs with rSRVCC capability.

Only the differences to the Alternative 1 are highlighted below.

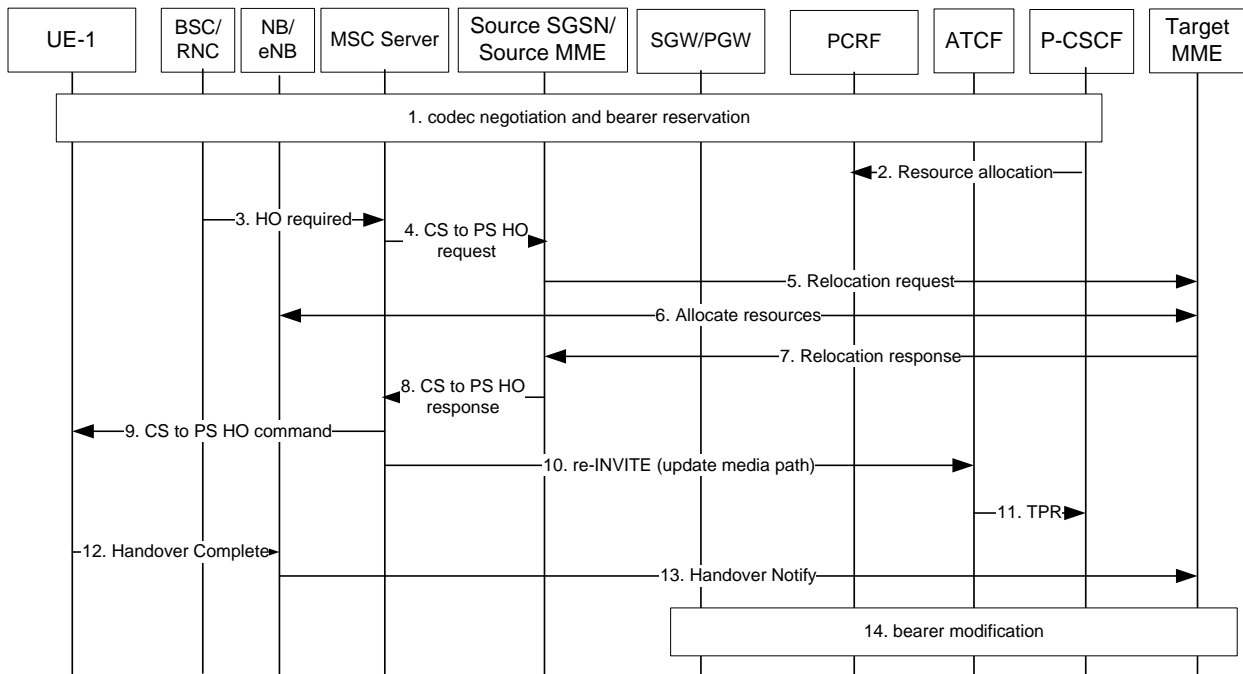

Figure 6.3.3.7.3-1: Access Transfer Preparation Alternative 3

Editor's Note: The role of the target MSC in this solution is FFS.

1. After the IMS registration or after successful rSRVCC handover, the UE negotiates the voice codec with the ATCF (via P-CSCF) using the standard SDP offer / answer procedure. Also the IP address and port number for the RTP voice media is negotiated at the same time. UE may use e.g. a preconfigured PSI to send the SDP offer in INVITE to the ATCF. Or alternatively, the UE may learn the PSI during the IMS registration. A special indicator may be set by UE or ATCF to indicate that this media reservation is only for the rSRVCC preparation. Note that only the IP address and port allocated by the local UE for voice after rSRVCC are used for establishing the pre-establishing the voice bearer in the network.

NOTE 1: when SRVCC takes place, the source MME/SGSN does not split the suspended QCI-1 bearer from the other PS bearers, but hands it over together with the other PS bearers. The non suspended QCI-1 bearers are released as per the current SRVCC procedures.

2. P-CSCF reserves the bearer for voice media (QCI=1) using the standard PCC procedures. A special media authorization rules can be used to authorize the QCI=1 bearer at PCRF even though the source RAT does not support GBR bearers, or there is no sufficient bandwidth available. The media flow is not activated at this point and the QCI=1 bearer is marked as suspended.
3. CS call is established as described elsewhere in this solution.

When the rSRVCC occurs, the RNC/BSC sends a HO required to the MSC Server including an indication this HO is for rSRVCC. Since the PS bearers are suspended, no HO required is send by RAN to the source SGSN.

4. The MSC Server sends a SRVCC CS to PS HO command to the Source SGSN or the source MME according to what it stored as "serving PS node" for the UE.
5. Source SGSN / source MME sends a relocation request to the target SGSN/MME. That message includes an indicator that the pre-established voice bearer status shall become active.

6. Target SGSN/MME allocates resources in UTRAN/E-UTRAN.
7. A relocation response is returned to the Source SGSN / source MME.
8. A SRVCC CS to PS HO response is returned from the Source SGSN / source MME to the MSC Server.
9. MSC sends HO required Ack to the RAN and the RAN send HO command to UE, indicating CS to PS handover. There is no need to add the coded information to the HO command, as the codec was negotiated prior to the SRVCC. The HO Command message includes the EPS bearer information related to the pre-established PS voice bearer, as well as the transport address of either the ATGW or the remote end.
10. In case of ATCF with media anchored in ATGW, the MSC Server sends a re-INVITE to the ATCF to trigger the ATCF/ATGW to have the media path switched to the IP address/port of the UE on the target access.
In case of without media anchored in ATGW, MSC Server sends a re-INVITE or INVITE to ATCF and the media path between ATCF/ATGW and the MSC Server/MGW is to be established.
11. ATCF is aware of the voice codec, IP address and port number which were negotiated with the UE prior to the SRVCC. Depending on the selected voice codec and the codec used in the ongoing session between ATCF and remote end, the ATCF/ATGW may begin to perform transcoding.

Editor's Note: The responsibility to release the voice bearer in error cases during this procedure are FFS.

NOTE 2: The MGW can for a certain period of time send media both on the source access leg and the new target access leg to minimize the interruption delay further.

12. The UE sends a Handover Complete message on the target RAN when it has successfully performed the handover.
13. The target RAN notifies the target MME/SGSN of the successful handover.
14. The target MME/SGSN initiates the Modify Bearer procedure, including an indicator that the suspended voice bearer now needs to be activated.

NOTE 3: when the IMS session continuity procedure takes place, the TFT of the PS voice bearer will be modified to take into account the transport address used by the ATGW or by the remote end.

6.3.3.7.4 Access Transfer Preparation Alternative 4

This alternative is similar with the Alternative 3 that UE and ATCF negotiate the codec, IP address, and port number for the RTP media by standard IMS session setup procedure prior to rSRVCC, e.g. sending an INVITE request immediately after the IMS registration. The major difference is that, in this alternative, MSC Server sends CS to PS handover request to target MME/SGSN instead of serving PS node.

The SDP offer in the INVITE request indicates to reserve a non-GBR voice media bearer (e.g. QCI=7) from the source RAT, e.g. by using "b=AS:0" line. The radio resource of the non-GBR voice media bearer will be released by source RAN in seconds.

After triggered to perform rSRVCC procedure, the MSC Server sends CS to PS handover request to target MME/SGSN via Sv interface, the target MME/SGSN may query PDP contexts/connections from source SGSN / old MME before performing standard PS-PS handover procedure.

The target MME/SGSN shall synchronize PS HO and CS to PS HO based on the IMSI and the rSRVCC HO indication sent from RNC/BSS to MSC Server/SGSN. The rSRVCC HO indication shows whether CS to PS HO is triggered or CS+PS to PS HO is triggered.

After UE tunes to target access network, UE can transfer voice media data using the non-GBR voice bearer temporarily. After UE complete the IMS Session Continuity procedure as described in clause 6.3.3.8, UE can transfer voice media data using new created GBR voice bearer (QCI=1) bearer.

Figure 6.3.3.7.4-1 shows an example of the solution when ATCF is involved in the IMS registration made by UE:

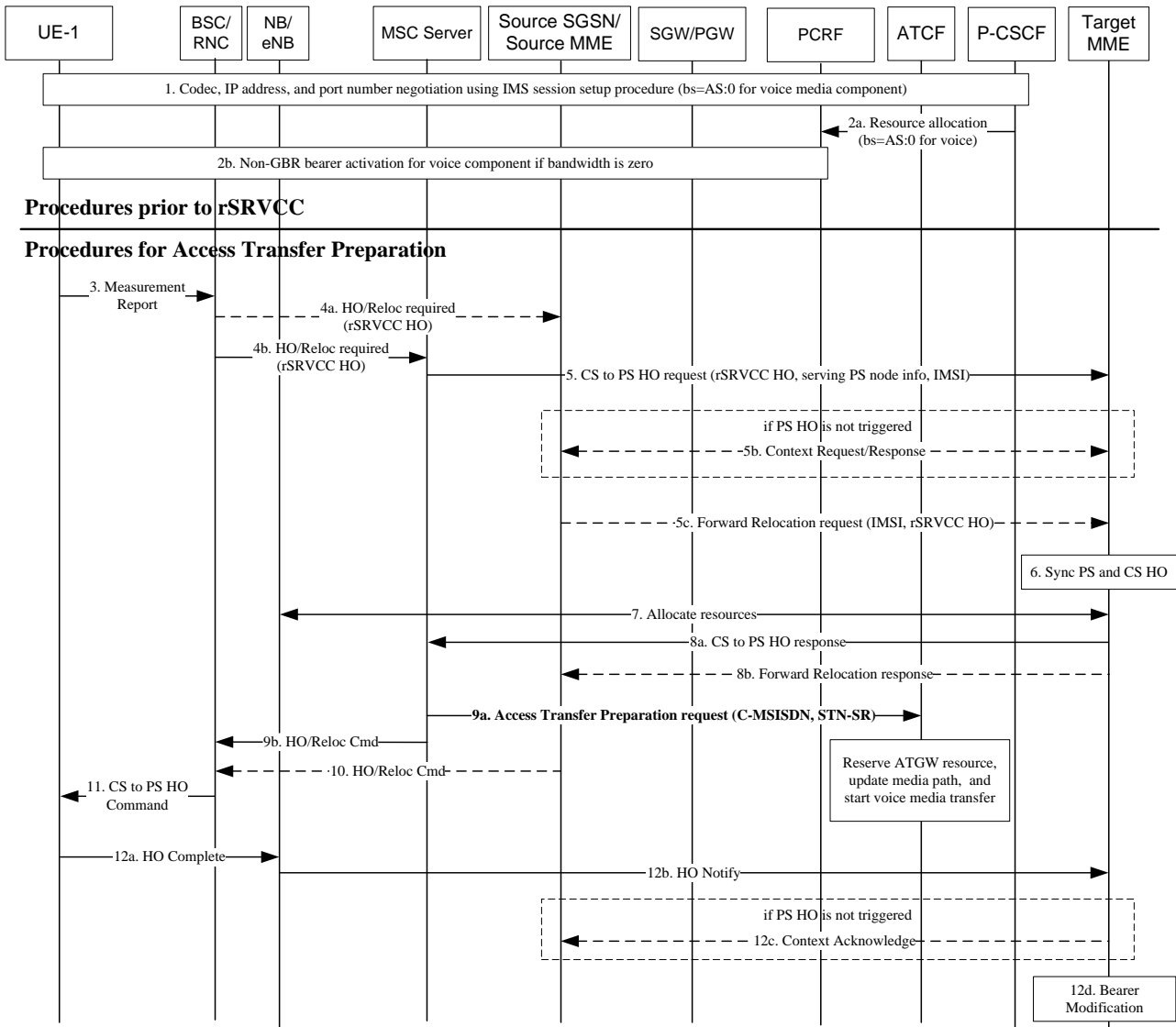

Figure 6.3.3.7.4-1: Access Transfer Preparation Alternative 4

Following step 1 and 2 are procedures prior to rSRVCC:

1. After the IMS registration, UE negotiates the voice codec, IP address, and port number for the RTP voice media with the ATCF (via P-CSCF) using the standard IMS session setup procedure, e.g. sending an SIP INVITE request. UE uses STI-rSR to send the SDP offer in a SIP INVITE request to the SCC AS via the ATCF, and uses "b=AS:0" in SDP offer to indicate the bearer reservation and session setup for rSRVCC. As bandwidth is zero, the ATGW will not handle the uplink traffic if sent by UE fraudulently. The ATCF forwards it to SCC AS immediately. When ATCF and SCC AS receives a SDP offer in a SIP INVITE with valid zero bandwidth voice media, then, if the SIP INVITE is destined to the STI-rSR, it responds with "b=AS:0" in the SDP answer, otherwise reject it.
2. P-CSCF reserves the bearer for voice media using the standard PCC procedures. Knowing from the zero bandwidth for voice media, the PCRF reserves a non-GBR voice media bearer (e.g. QCI=7).

Following steps are procedures for Access Transfer Preparation:

3. UE sends Measurement Report message.
4. Source RNC/BSS knows that UE is able to perform rSRVCC as described in clause 6.3.3.3a, and determines to trigger rSRVCC procedure. The following steps are performed :
 - a) If UE is active in PS domain, and UTRAN supports PS HO or GERAN support DTM HO, source RNC/BSS sends Handover/Relocation Required message with rSRVCC HO indication to source SGSN. The rSRVCC

HO indication can use e.g. new defined values of "CS to PS relocation triggered" and "CS+PS to PS relocation triggered" for Cause IE. The Cause IE is transparent to source SGSN for Inter-RAT handover.

- b) In parallel with step a), source RNC/BSS sends Handover/Relocation Required (rSRVCC HO) message to anchor MSC Server.
5. Target MME/SGSN handles handover request from PS domain and CS domain as follows:
 - a) Receives the CS to PS handover request (rSRVCC HO, serving PS node info, IMSI) from MSC Server enhanced for rSRVCC. The "serving PS node info" is obtained according to clause 6.3.3.9.
 - b) If PS HO is not triggered, sends Context Request to source SGSN / old MME and receives the response.
 - c) If PS HO is triggered, wait for receiving the Forward Relocation Request (rSRVCC HO, IMSI) from source SGSN. The rSRVCC HO is received from source RNC/BSS and transparently forwarded by the source SGSN.
 6. Target MME/SGSN synchronizes PS handover and CS to PS handover based on the rSRVCC HO indication and IMSI. The rSRVCC HO also indicates whether PS HO is triggered or not.
 7. Target MME/SGSN allocates resources from target eNB/RNC.
 8. If resource allocation is done, target MME/SGSN finishes the handover preparation procedure. The following steps are performed:
 - a) Target MME/SGSN sends CS to PS handover response to MSC Server enhanced for rSRVCC. When resource allocation fails, the target MME/SGSN shall send a reject indication to the MSC Server.
 - b) In parallel with step a), if PS handover is triggered, target MME/SGSN sends Forward Relocation Response to source SGSN.
 9. MSC Server enhanced for rSRVCC handles the CS to PS handover response as follows:
 - a) Sends Access Transfer Preparation request (C-MSISDN, STN-SR) to the ATCF, e.g. by using SIP INVITE request. In case of media path anchored in ATGW, if transcoding is needed, the media path between ATCF/ATGW and the MSC Server/MGW may be established by ATCF to make the MSC Server/MGW performing transcoding.

The ATCF interacts with ATGW to reserve the resources, have the media path switched, and start voice data transfer for the session established at step 1.

 - b) In parallel with step a), sends Handover/Relocation Command to source RNC/BSS.
 10. If PS HO is triggered, after step 8c, source SGSN sends Handover/Relocation Command message to source RNC/BSS.
 11. Source RNC/BSS sends Handover from UTRAN/GERAN Command message to UE, indicating CS to PS handover, e.g. by including RAB info to remove IE that contains the CS RAB information. There is no need to add the codec and NAS information (e.g. TFT, EPS bearer ID, etc) to the HO from UTRAN/GERAN Command, as the codec and NAS information was negotiated prior to the rSRVCC.

NOTE: After UE tunes to E-UTRAN, to minimize the interruption delay, it can use the non-GBR voice media bearer to continue to transfer voice data until a GBR voice media bearer (QCI=1) for the session has been created.

12. UE tunes to LTE/HSPA, and following steps are performed:
 - a) UE sends Handover complete message to target eNB/RNC, the UE also resumes the existing PS bearers in case those were suspended.
 - b) Target eNB/RNC sends Handover Notify message to target MME/SGSN.
 - c) If PS HO is not triggered, target MME/SGSN sends Context Acknowledge to source SGSN / old MME. When resource allocation fails or UE fails to camp on E-UTRAN/HSPA, the target MME/SGSN shall send a reject indication to the source SGSN / old MME, e.g. by using "no resource available" or "system failure" cause value.

- d) Target MME/SGSN performs bearer modification procedure towards the SGW/PGW, effectively completing the EPS-level handover procedure. Note that in case the PS bearers were suspended, they are resumed in the SGW/PGW as an implicit result of the bearer modification procedure.

Editor's note: It is FFS what if UE fails to establish QCI=1 bearer after tunes to target access, e.g. due to lack of radio resources.

6.3.3.7.5 Access Transfer Preparation Alternative 5 (the combination)

The more detailed procedures of the Access Transfer Preparation steps are shown in the following figure.

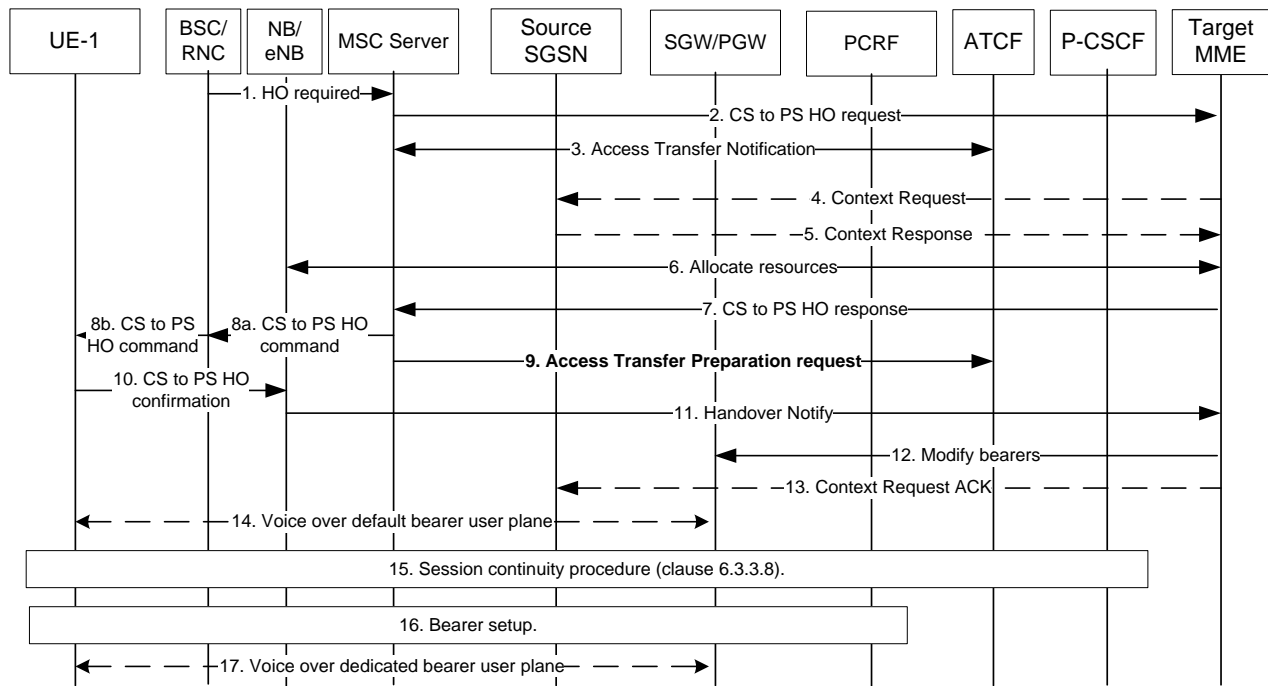

Figure 6.3.3.7.5-1: Access Transfer Preparation Alternative 5, non-DTM case

1. The RNC/BSC sends a HO required to the MSC Server including an indication this HO is for rSRVCC. If the MSC Server is the target MSC, it forwards the HO required to the anchor MSC Server.
2. The MSC Server sends a SRVCC CS to PS HO request to the Target MME. If required, the IMSI is provided for identifying the UE.
3. The MSC Server sends an Access Transfer Notification to the ATCF, e.g. a SIP re-INVITE or INVITE message, which indicates the ATCF that it should prepare for the transfer of media to PS. The ATCF allocates media ports on the ATGW. The media ports and codecs allocated by the ATCF are provided to the MSC Server in the response message. This step is independent of step 2.

NOTE 1: The ATCF retrieves the ports/codecs received from the UE in its IMS registration. The ATCF is able to correlate the IMS registration made by the UE and the one made by the MSC Server on behalf of the UE for instance based on the C-MSISDN or on the IMEI derived instance-id used by both those registrations.

NOTE 2: The Access Transfer Notification message could e.g., be implemented using an INVITE or other appropriate message. It is left for stage 3 to decide on appropriate message.

4. If the MME has no UE context it sends Context Request using P-TMSI and RAI to find the old SGSN.
5. The SGSN responses with Context Response message including all UE contexts.
6. Target MME allocates resources in E-UTRAN.
7. A SRVCC CS to PS HO response is returned from the target MME to the MSC Server.

8. MSC Server sends HO required Ack to the RAN, possibly via the target MSC, and the RAN send HO command to UE, indicating CS to PS handover. The MSC Server also includes in that message the IP address/ports and selected codec for the ATGW.
9. In case of ATCF with media anchored in ATGW, the MSC Server sends an Access Transfer Preparation Request, e.g. a SIP re-INVITE or P-ACK message, to the ATCF to trigger the ATCF/ATGW to have the media path switched to the IP address/port of the UE on the target access.

In case of ATCF without media anchored in ATGW, MSC Server sends an Access Transfer Preparation Request to ATCF and the media path between ATCF/ATGW and the MSC Server/MGW is to be established.

10. The UEs send Handover confirmation to the eNB.
11. The eNB send Handover Notify to the MME.
12. The MME sends Modify Bearer Request to the SGW, which is forwarded to the PGW to update PS bearer contexts.
13. The MME sends the Acknowledgment to the Context Response to the SGSN.
14. The voice media is started directly.

NOTE 3: During a short period of time prior the RAT has been changed and the new bearer has been established, the media will be sent over the default bearer.

15. The UE initiates the session continuity procedures according to clause 6.3.3.8 towards the ATCF.
16. As a result of the session continuity procedures, the bearer setup is performed (initiated by the P-CSCF).
17. The voice media is sent in the dedicated bearer.

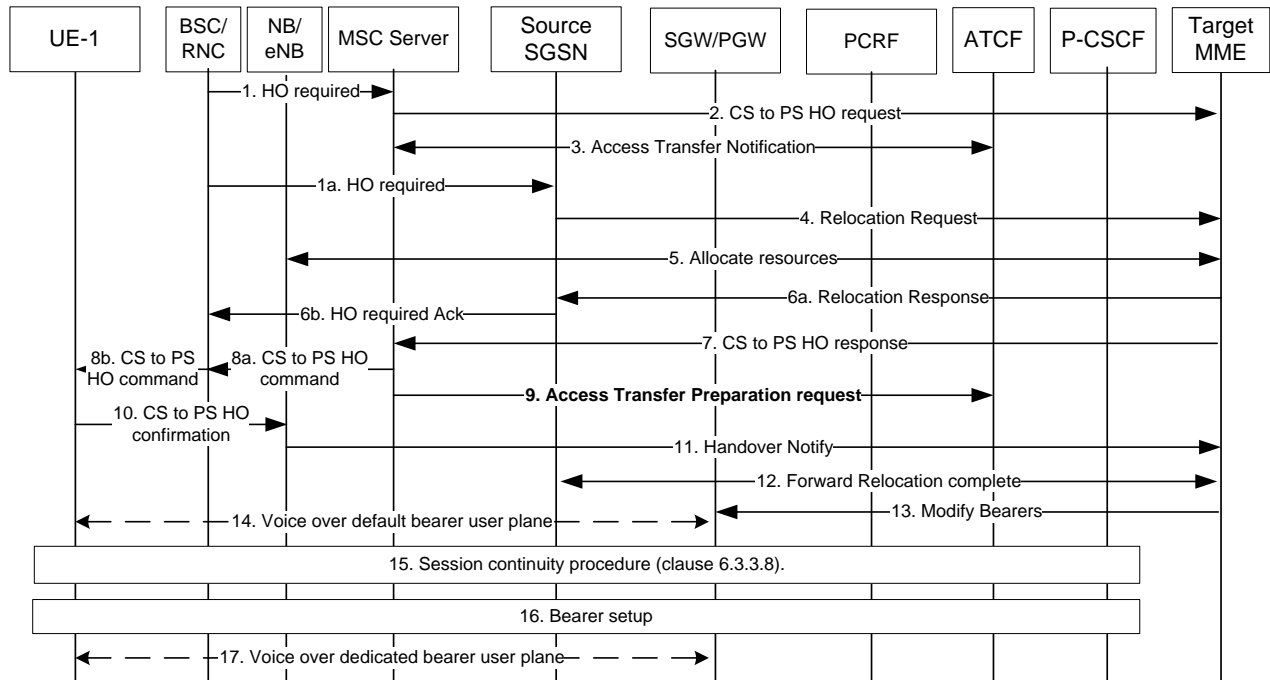

Figure 6.3.3.7.5-2: Access Transfer Preparation Alternative 5, DTM case

1. The RNC/BSC sends a HO required to the MSC Server including an indication this HO is for rSRVCC. If the MSC Server is the target MSC, it forwards the HO required to the anchor MSC Server.
- 1a. In the DTM case the UE is active in PS domain, the RNC/BSC sends also a Relocation Required message to source SGSN.

2. The MSC Server sends a SRVCC CS to PS HO request to the Target MME. If required, the IMSI is provided for identifying the UE.
3. The MSC Server sends an Access Transfer Notification to the ATCF, e.g. a SIP re-INVITE or INVITE message, which indicates the ATCF that it should prepare for the transfer of media to PS. The ATCF allocates media ports on the ATGW. The media ports and codecs allocated by the ATCF are provided to the MSC Server in the response message. This step is independent of step 2.

NOTE 4: The ATCF retrieves the ports/codecs received from the UE in its IMS registration. The ATCF is able to correlate the IMS registration made by the UE and the one made by the MSC Server on behalf of the UE for instance based on the C-MSISDN or on the IMEI derived instance-id used by both those registrations.

NOTE 5: The Access Transfer Notification message could e.g., be implemented using an INVITE or other appropriate message. It is left for stage 3 to decide on appropriate message.

4. Source SGSN sends Relocation Request to the target MME.
5. Target MME allocates resources in E-UTRAN.
- 6a. A relocation response is returned to the Source SGSN.
- 6b. Source SGSN sends HO Required Ack to RAN.
7. A SRVCC CS to PS HO response is returned from the target MME to the MSC Server.
8. MSC Server sends HO required Ack to the RAN, possibly via the target MSC, and the RAN send HO command to UE, indicating CS to PS handover. The MSC Server also includes in that message the IP address/ports and selected codec for the ATGW.
9. In case of ATCF with media anchored in ATGW, the MSC Server sends an Access Transfer Preparation Request, e.g. a SIP re-INVITE or P-ACK message, to the ATCF to trigger the ATCF/ATGW to have the media path switched to the IP address/port of the UE on the target access.

In case of ATCF without media anchored in ATGW, MSC Server sends an Access Transfer Preparation Request to ATCF and the media path between ATCF/ATGW and the MSC Server/MGW is to be established.

10. The UEs send Handover confirmation to the eNB.
11. The eNB send Handover Notify to the MME.
12. The MME sends Forward relocation Complete to the old SGSN.
13. The MME sends Modify Bearer Request to the SGW which is forwarded to the PGW to update PS bearer contexts.
14. The voice media is started directly.

NOTE 6: During a short period of time prior the RAT has been changed and the new bearer has been established, the media will be sent over the default bearer.

15. The UE initiates the session continuity procedures according to clause 6.3.3.8 towards the ATCF.
16. As a result of the session continuity procedures, the bearer setup is performed (initiated by the P-CSCF).
17. The voice media is sent in the dedicated bearer.

6.3.3.8 IMS Session Continuity procedure

6.3.3.8.0 General

IMS Session Continuity procedure can be accomplished by sending an Access Transfer Complete request to IMS, e.g. by using a SIP INVITE. If the ATCF was involved in the IMS registration made by UE, the P-CSCF routes the Access Transfer Complete request to the ATCF. The Access Transfer Complete request to IMS is addressed using a dynamically provided STI-rSR (Session Transfer Identifier for rSRVCC).

If the ATCF was involved and receives an Access Transfer Complete request, it notifies the SCC AS about the fact the UE has now moved to the target access. The SCC AS then releases the source access leg as described in 3GPP TS 23.237 [4].

If MSC Server receives the release of the original dialog, it shall release the dialog between the MSC Server and the allocated ATCF.

6.3.3.8.1 Anchored in ATGW

Following figure 6.3.3.8.1-1 shows an example that ATCF is involved in the IMS registration made by UE and ATGW anchors the media.

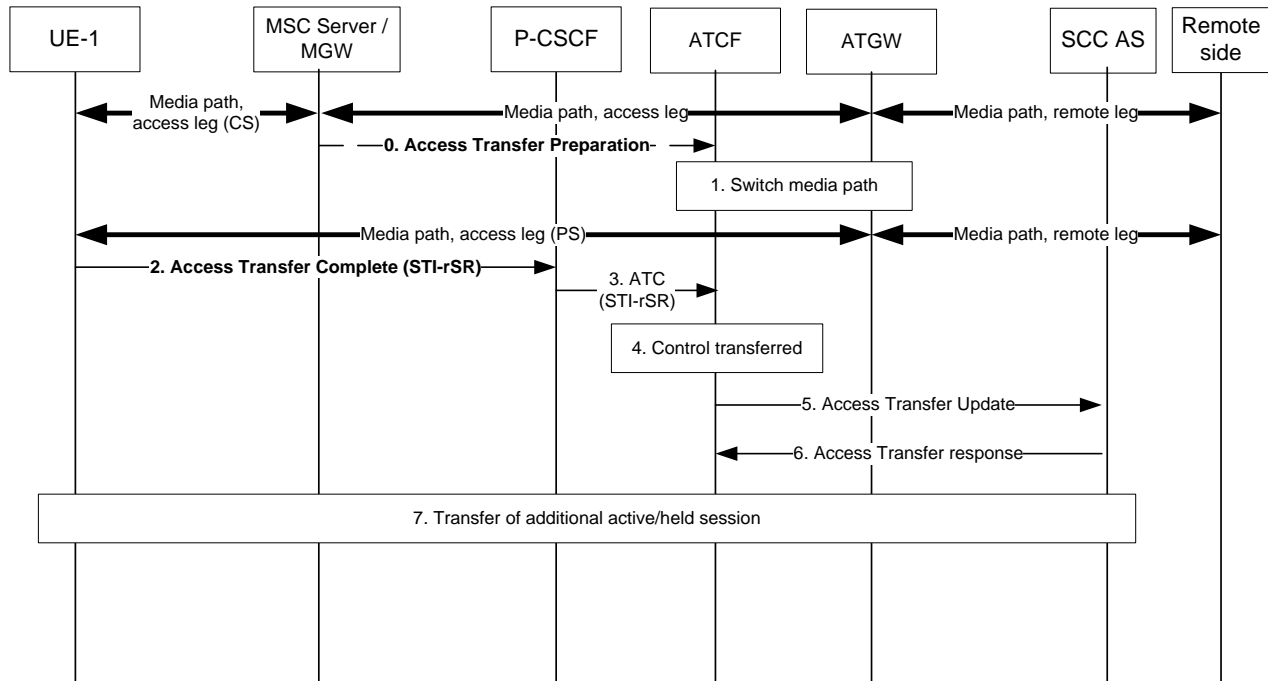

Figure 6.3.3.8.1-1: IMS Session Continuity procedure – with media anchored in ATGW

- The IMS Session Continuity procedure starts when the media path switching is requested from the MSC server during the Access transfer preparation phase (see Step 12 in clause 6.3.3.7.1, Step 8b in clause 6.3.3.7.2, Step 10 in clause 6.3.3.7.3, and Step 9a in clause 6.3.3.7.4 respectively).
- When receiving the Access Transfer Preparation request from the MSC Server, the ATCF updates the ATGW to switch the media path to the PS access leg. For alternative 3 and 4, the access media leg is switched to the access media leg of the pre-established session.
- When the UE has moved to PS, it can receive media on the pre-decided ports. It will re-establish the session control of the media by sending an Access Transfer Complete request with the provided STI-rSR, e.g. by using a SIP INVITE request. For alternative 1, 2 and 3, it shall use the media information it already uses.
For alternative 4, if a new QCI=1 bearer has been created, UE uses it for voice media data transfer.
- The Access Transfer Complete request is forwarded to the ATCF.
- The ATCF correlates the Access Transfer Complete request with the Access Transfer Preparation request and the ongoing sessions, and moves the session control of the session to the new access leg. For alternative 4, the ATCF informs the UE to use the codec that original session used if possible.
- After receiving the Access Transfer Complete request, the ATCF re-establishes the communication with the SCC AS and updates the SCC AS that the transfer has taken place by sending an Access Transfer Update message to the SCC AS. As there is no update in the session description, no remote end update will be sent by the SCC AS.
- The SCC AS sends confirmation response to the ATCF.

7. The UE may initiate transfer of any additional active/held session.

6.3.3.8.2 Not Anchored in ATGW

Following figure 6.3.3.8.2-1 shows an example that ATCF is involved in the IMS registration made by UE and not involved in the IMS registration made by MSC Server.

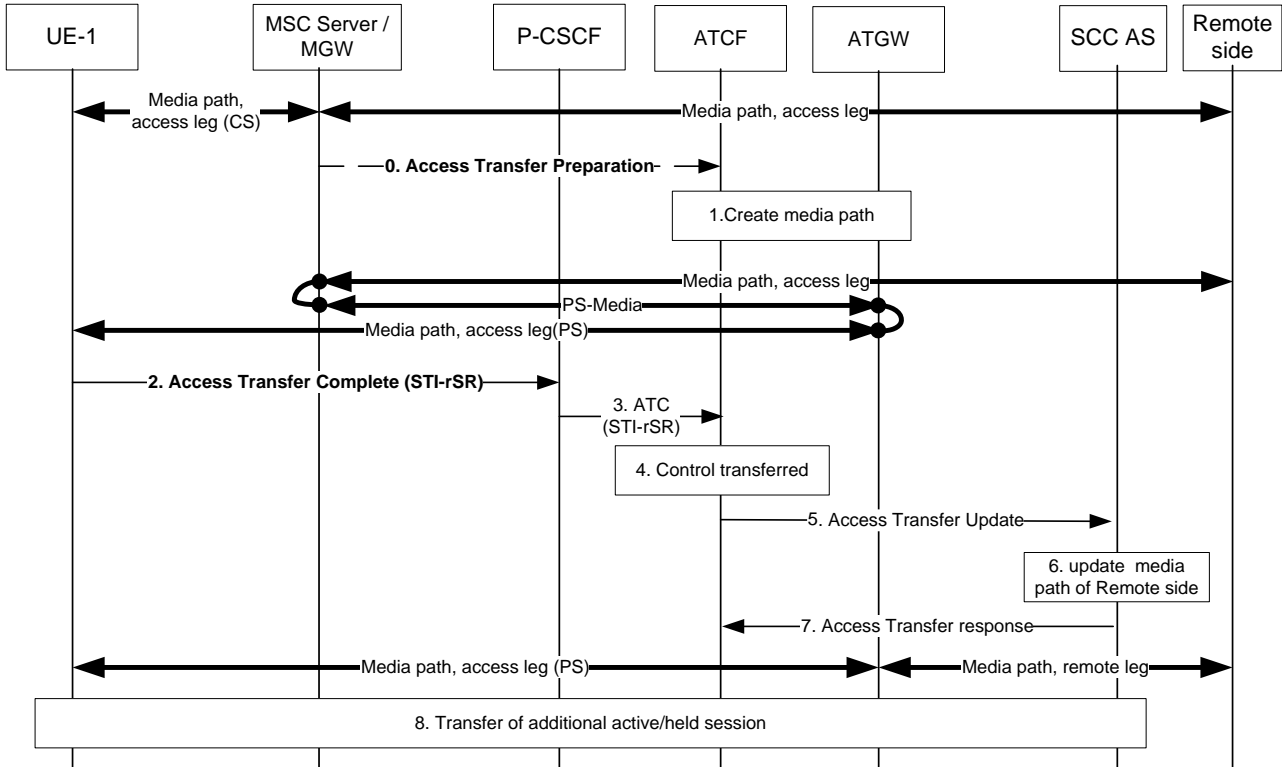

Figure 6.3.3.8.2-1: IMS Session Continuity procedure - without media anchored in ATGW

0. The IMS Session Continuity procedure starts when the media path switching is requested from the MSC server during the Access transfer preparation phase (see Step 12 in clause 6.3.3.7.1, Step 8b in clause 6.3.3.7.2, Step 10 in clause 6.3.3.7.3, and Step 9a in clause 6.3.3.7.4 respectively).

1. When receiving the Access Transfer Preparation request from the MSC Server, the ATCF reserves ATGW resources for the media path connected to MSC Server/MGW.

2. When the UE has moved to PS, it can receive media on the pre-decided ports. It will re-establish the session control of the media by sending an Access Transfer Complete request with the provided STI-rSR, e.g. by using a SIP INVITE request. For alternative 1, 2 and 3, it shall use the media information it already uses.

For alternative 4, if a new QCI=1 bearer has been created, UE uses it for voice media data transfer.

3. The Access Transfer Complete request is forwarded to the ATCF. If ATCF was not involved in the IMS registration procedure made by UE, the Access Transfer Complete request is forwarded to the SCC AS.

Following steps 4, 5 and 7 is for ATCF involved in the IMS registration made by UE.

4. The ATCF correlates the Access Transfer Complete request with the Access Transfer Preparation request, and moves the session control of the session to the new access leg. For alternative 4, the ATCF informs the UE to use the codec that original session used if possible.

5. After receiving the Access Transfer Complete request, the ATCF re-establishes the communication with the SCC AS and updates the SCC AS that the transfer has taken place by sending an Access Transfer Update request to the SCC AS. The ATCF updates the ATGW to switch the media path to the PS access leg. For alternative 1 and 2, the access media leg is switched to the access media leg pre-negotiated during IMS registration procedure made by UE. For alternative 3 and 4, the access media leg is switched to the access media leg of the pre-established session.

6. After receiving the Access Transfer Update/Access Transfer Complete request, the SCC AS may send remote end update.
7. The SCC AS sends confirmation response to the ATCF.
8. The UE may initiate transfer of any additional active/held session.

6.3.3.9 Identification of serving PS node

6.3.3.9.1 Alternative 1: CN nodes based

Provision of the SGSN identity to the MSC via HSS Insert Subscriber Data and via SGSN notifications

1. SGSN functionality:
 - At Attach and at Inter-SGSN routing area update, the new SGSN gets the address of the MSC serving the UE in the Insert Subscriber Data which it receives from the HSS as part of the existing procedure.
 - The SGSN then notifies the MSC (serving or anchor) that it has become the serving SGSN for the user if the UE is rSRVCC capable, and if the MSC is rSRVCC capable.
2. Additional MSC functionality:
 - At IMSI Attach and at Inter-MSC Location Area Update, if an SGSN is serving the UE, the MSC stores as "serving PS CN node" the address of the serving SGSN it receives from the HSS in the Insert Subscriber Data as part of the Location Area Update.
 - When getting notified by an SGSN, the MSC stores as "serving PS CN node" the identity of the SGSN that issued the notification.
 - At SRVCC, the MSC initializes the "serving PS CN node" to the identity of the MME that issued the PS to CS request.
3. Additional HSS functionality:
 - The HSS needs to include the serving MSC identity in the Insert Subscriber Data it sends to the SGSN.
4. Additional UE functionality:
 - The UE signals its rSRVCC capability to the SGSN at Attach and at Routing Area Update.

At SRVCC handover combined with PS handover, the UE needs to slightly delay the sending of the Routing Area Update it sends once getting on the target access. (This would be required to make sure the MSC has performed the Location Updating towards the HSS, and that the SGSN will therefore be able to get the identity of the MSC it needs to notify).

6.3.3.9.2 Alternative 2: UE and/or RAN provided information

UE packs one of the following information into rSRVCC IE, which can be used by the MSC to locate source SGSN / old MME:

- a. RAI, P-TMSI, and P-TMSI signature if serving PS node is in UTRAN network.
- b. RAI and TLLI if serving PS node is in GERAN network.
- c. GUTTI if serving PS node is in E-UTRAN network.

UE reports rSRVCC IE to RNC/BSC when it is involved in CS call establishment (including CS MO/MT, CS handover, and SRVCC cases).

Examples of methods that could be used to report the rSRVCC IE to the RNC/BSC:

- RRC message: examples are the ASSIGNMENT COMPLETE message and HANDOVER COMPLETE messages (the "RRC Measurement Report" message shall not be used). The inclusion of rSRVCC IE shall be according to clause 10.1.1.1.2 of TS 25.331 for non-critical extension of a RRC message with additional

information elements (currently RAN2 does not recommend modifying RRC messages to include rSRVCC Info IE) or clause 8.6.1 of TS 44.018 [13].

- Suspend procedure in case of non-DTM capable GERAN network
- Additional RA U procedure or assignment procedure for UE in dedicated mode.
- For UE in dedicated mode, in case of normal CS HO but without RA change (e.g. inter RNC HO without RA change), following methods can be used:
 - a. the UE reports rSRVCC IE to RNC/BSC using handover complete procedure.
 - b. the source RNC/BSC sends the rSRVCC IE to target RNC/BSC by including it in the Transparent Container.

NOTE: Which method is used needs to be decided by RAN groups / stage 3.

RNC/BSC includes the rSRVCC Info IE in Handover/Relocation Required message for CS to PS handover, e.g. by including the rSRVCC Info IE into GERAN Classmark.

The following figure shows an example call flow.

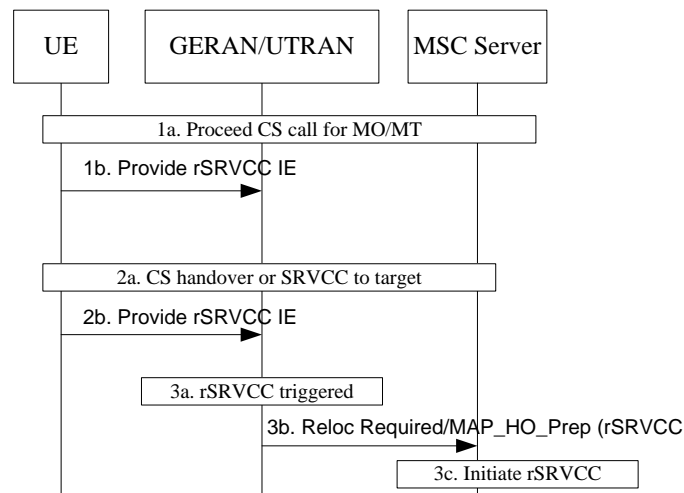

Figure 6.3.3.9.2-1

1. UE involves in CS session by proceeding CS MO/MT procedure. UE packs the serving PS node information into rSRVCC IE and reports the rSRVCC IE to RNC/BSC. In case the used message contains already the serving PS node information, then there is no need to include the rSRVCC IE additionally and the RNC/BSC can construct the rSRVCC IE on its own.
2. UE involves in CS session by performing SRVCC procedure. UE packs the serving PS node information into rSRVCC IE and reports the rSRVCC IE to RNC/BSC. In case the used message contains already the serving PS node information, then there is no need to include the rSRVCC IE and the RNC/BSC can construct the rSRVCC IE on its own. In case of inter-SGSN change or intra SGSN with RAI change and the BSC/RNC has generated P-TMSI/TLLI+target RAI the RNC/BSC can replace the P-TMSI/TLLI+RAI received from the UE with the RNC/BSC generated P-TMSI/TLLI+target RAI pointing to the target SGSN.
3. When the RNC/BSC supporting rSRVCC triggers the rSRVCC procedure, it sends Relocation Required/Handover Required message with received rSRVCC IE content to anchor MSC Server. The anchor MSC Server sends MAP-Handover-Preparation request with the received rSRVCC IE content to target MSC Server.

6.3.3.9.3 Alternative 3: RAN provided information

According to 6.3.3.9.2:

Regarding bullet a and bullet b where GERAN is DTM capable:

In case of UTRAN or DTM capable GERAN network, during attachment procedure or RAU procedure, the RNC/BSC has the information pointed to the serving SGSN, which can be stored in RNC/BSC in case of active CS session. When RNC/BSC needs to start rSRVCC HO, it includes this serving SGSN address as part of the HO signalling toward the MSC enhanced for rSRVCC.

As RNC/BSC have no UE context for the UE in PS idle mode, the UE should initiate additional RAU to provide the RNC or BSC with the RAI/P-TMSI/P-TMSI signature or RAI/TLLI respectively when initiating CS call.

In case of normal CS HO without RA change for PS idle mode UE, there seem two alternative solutions as described below:

- 1) The serving SGSN information is to be transferred as BSC-to-BSC / RNC-to-RNC information in Handover / Relocation Required and Handover / Relocation Request messages and the target RNC/BSC stores the related information for future rSRVCC HO procedure.
- 2) In normal CS HO procedure, the source RNC/BSC reuses the rSRVCC Info IE to include the serving SGSN information in Handover / Relocation Required message and the anchor MSC Server stores the related information for future rSRVCC HO procedure.

Regarding bullet b where GERAN is Non-DTM capable:

In case of Non-DTM capable GERAN network, according to clause 16.2.1.1.1 of TS 23.060 [6], it seems the suspend procedure can be reused to transfer RAI and TLLI to BSC.

In this case, when UE has been involved in active CS call, the UE sends RR Suspend (TLLI, RAI) message to the BSC and BSC stores the related information. If the MS performs an inter-BSC handover while suspended, the TLLI and RAI should be transferred as BSC-to-BSC information in the Handover Required and Handover Request messages.

Please note that MSC Server only uses RAI/TLLI to resolve the address of the serving MME and IMSI still needs to be transferred to MME for UE identification.

Regarding bullet c:

This applies to the scenario of CS voice call established during SRVCC from E-UTRAN to GERAN without DTM support where the UE will be in GPRS PS suspend state in GERAN.

In this case, the UE will send RR Suspend with TLLI/RAI to BSC that is mapped from GUTI pointed to old serving MME and the following procedure is similar with the bullet b.

Alternatively, SRVCC MSC Server is the anchor MSC Server and can store the information of serving MME node. Assuming SRVCC MSC Server can also act as rSRVCC MSC Server, the stored MME information can be used by the anchor MSC Server to find the correct MME.

NOTE: The SRVCC MSC Server is able to find the source MME based on the received information during SRVCC PS to CS procedure according to TS 29.280 [14].

During rSRVCC procedure, RNC/BSC includes the rSRVCC Info IE with serving SGSN/MME information in Handover/Relocation Required message for CS to PS handover, which is used by MSC Server to find the serving SGSN/MME correctly.

6.3.4 IMS registration Considerations

6.3.4.1 General

As a prerequisite for rSRVCC, the UE is IMS registered over PS.

6.3.4.2 ATCF controlled registration

To avoid that the IMS registration expires during an ongoing voice call over GERAN/ UTRAN without DTM support, the ATCF instructs the P-CSCF as follows:

- While the voice call is ongoing on the CS access leg (to/from the ATCF), the P-CSCF shall update the local registration timer of the PS access leg such that it does not expire during the ongoing call.

- If needed, the P-CSCF will also further instruct the S-CSCF to update its registration timer for the PS access leg such that it does not expire during the ongoing call.

After releasing the voice call(s), and if needed, the UE itself updates the IMS registration, i.e. in case the original IMS registration timer on the UE has already expired, the UE will immediately perform re-registration.

NOTE: If the UE's IMS registration timer expires locally during the ongoing call, the UE ignores this until the call is completed and is able to perform a re-registration.

Following figure shows an example of the solution:

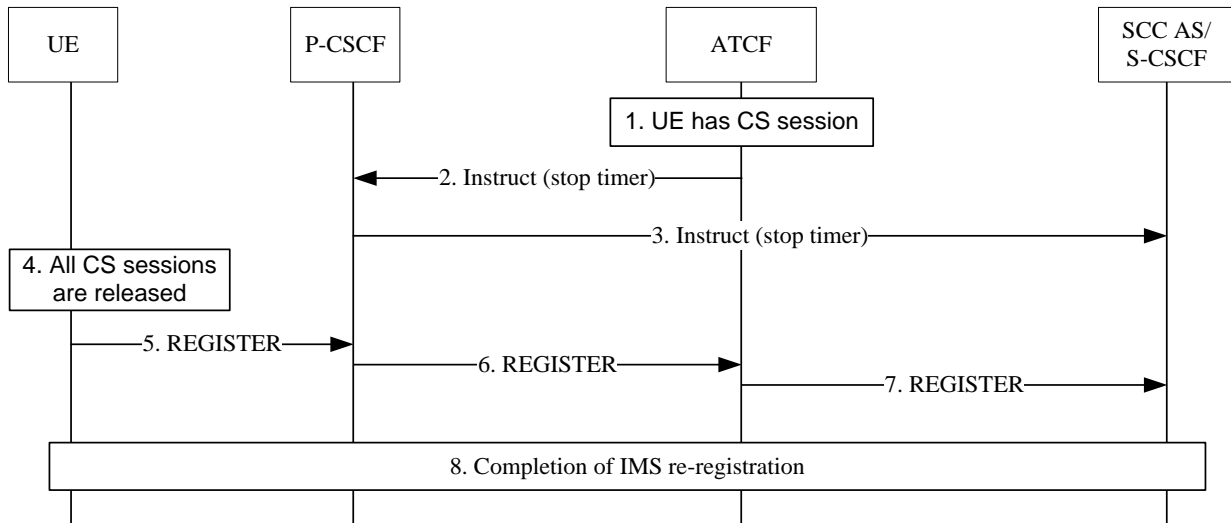

Figure 6.3.4.2-1: ATCF controlled registration

Editor's Note: It is FFS that whether a resume timer is needed and what if CS session is not anchored on ATCF.

6.3.4.3 SCC AS controlled registration

During the IMS (re-)registration procedure, The UE shall send a SIP REGISTER request with an additional time interval T_{maintain} to IMS to maintain IMS registration when UE is involved in CS session. The time interval for IMS re-registration is called $T_{\text{Registration}}$. In order not to impact P-CSCF, the T_{maintain} shall be included in the Expires header field of the SIP REGISTER request and the response.

The S-CSCF shall not reduce the T_{maintain} if the 3rd party registration needs to be performed to a SCC AS. The S-CSCF may reduce the $T_{\text{Registration}}$ according to local policy. The S-CSCF shall forward the $T_{\text{Registration}}$ to the SCC AS via 3rd party registration procedure and forward the $T_{\text{Registration}}$ to the UE, e.g. by including the $T_{\text{Registration}}$ in the response to the SIP REGISTER request.

The SCC AS may hold a time interval T_{Transfer} corresponding to the approximate transfer time of the SIP REGISTER request. The SCC AS shall reset the time interval for monitoring IMS re-registration to $(T_{\text{Registration}} + T_{\text{Transfer}})$ when all CS sessions of the UE has been released or the UE re-registration has been informed, and stop monitoring the IMS re-registration when CS session of the UE can be detected. If the time expired, the SCC AS shall inform the HSS to de-register the UE.

Following figure shows an example of the solution:

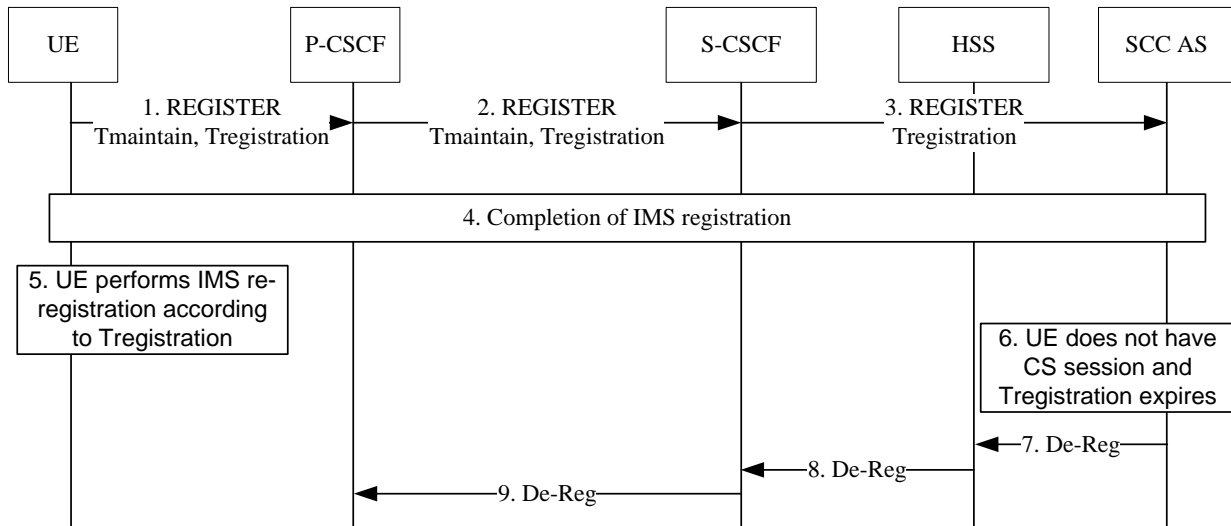

Figure 6.3.4.3-1: SCC AS controlled registration

6.3.4.4 rSRVCC HO Cancellation in case of UE loss of IMS registration

The clause handles the case the IMS registration from the UE expires during an ongoing call.

Two steps are performed to handle the IMS registration expiration.

1. MSC Server subscribes to the UE’s IMS registration status.

NOTE 1: This does not imply the use of Subscribe at stage 3.

2. The MSC Server uses the IMS registration status to ensure that full rSRVCC procedures are not performed, when the session may be lost due to de-registration.

Figure 6.3.4.4-1 provides the procedures of how the MSC server subscribes to the UE’s IMS registration status and is notified with changes.

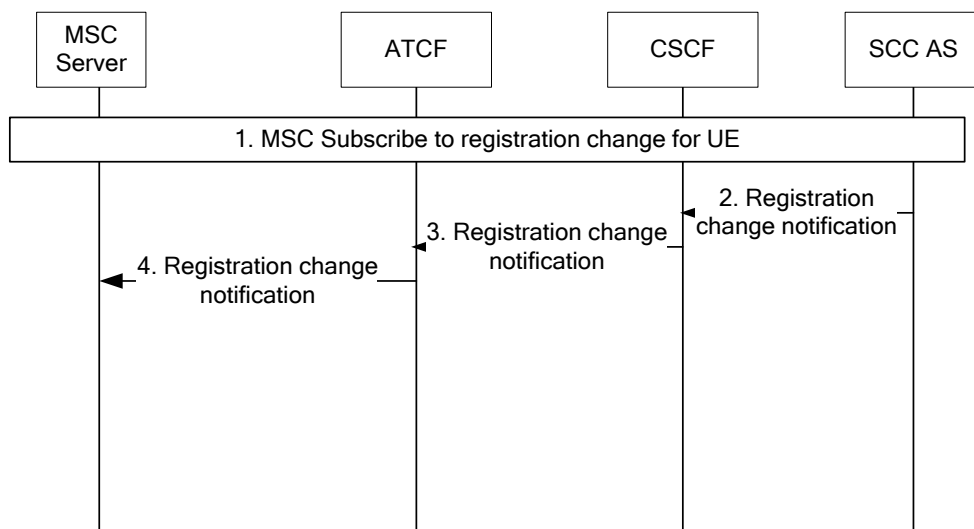

Figure 6.3.4.4-1: Subscription to UE’s IMS registration status

1. MSC Server subscribes to the UE’s IMS registration status.

- 2-4. If the UE’s IMS registration status changes, the MSC Server is notified by the IMS network.

Figure 6.3.4.4-2 provides the procedures of how the MSC server handles errors when HO Required is received.

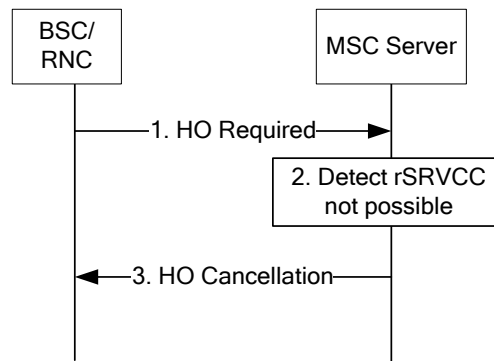

Figure 6.3.4.4-2: Error handling during HO.

1. The RNC/BSC sends a HO required to the MSC Server including an indication this HO is for SRVCC.
2. The MSC Server checks if HO is possible, e.g., that the UE is still registered in IMS (additional checks may be performed, such as if MSC server have a registration through ATCF). In this flow, the MSC Server detects that rSRVCC cannot be performed.
3. MSC Server cancels the HO.

NOTE 2: After receiving the HO cancellation due to rSRVCC, the RNC/BSC will not perform further HO attempts for rSRVCC.

6.4 Solution 4: Session transfer by local anchoring with Indirect Forwarding

6.4.1 Functional Description

This solution is a counter part of the alternative 12 in the TR 23.856 [8] such as enhancement of the SRVCC currently studied in SA2. This alternative aims to provide high performance in handover between CS domain voice service and LTE/HSPA IMS based voice media service by anchoring in local network.

This solution is provided by the following components.

- New routing number for the MSC Server/MGW enhanced for SRVCC is adapted in this solution in order to establish the CS domain connection between UE and the MSC Server/MGW enhanced for SRVCC.

Editor's Note: How UE gets new routing number is FFS. It is also possible to route to the MSC Server/MGW enhanced for SRVCC by adding prefix information in front of called number. In this case, added prefix is translated in the MSC. If the MSC Server/MGW enhanced for SRVCC is collocated to every MSC in the VPLMN, new routing number is not needed at all.

- The call control is mainly performed in IMS infrastructure coordinated with the CS domain call control, PCC architecture and EPC session control.
- The PCC and EPC are enhanced for exchanging session related information between the SCC AS and the MSC Server/MGW enhanced for SRVCC.
- Once the MSC Server/MGW enhanced for SRVCC receives a call establishment request from the UE, the MSC Server/MGW enhanced for SRVCC contacts to the SCC AS to inform an IP address of the its MGW. This IP address is conveyed to SGSN via P-CSCF, PCRF, PGW and SGW. Then SGSN use this IP address to contact to the MGW to establish the EPC bearer between SGW and MGW for VoIP media.
- The EPC is enhanced to establish Y shape connection anchored by the SGW. The Y shape is structured by one leg between PGW and UE as normal EPC bearer for packet domain, and the other one leg between PGW and the MSC Server/MGW enhanced for SRVCC for rSRVCC specific EPC bearer. Both legs are anchored by the SGW. The high HO performance can be achieved by this connection model since this model utilizes the inter RAT HO and no "session transfer" is required if PS HO is supported, i.e. SIP signalling session is kept both before and after HO.

- For both origination and termination, the SIP level call control and CS domain call control can be executed parallel in order to minimize call setup time.

Editor's Note: It is FFS how to support non-DTM support case.

Editor's Note: It is FFS how to handle the case where inter-MSC handover happens in this solution.

6.4.2 Architecture Reference Model

The Figure 6.4.2-1 shows the architecture reference model of this solution.

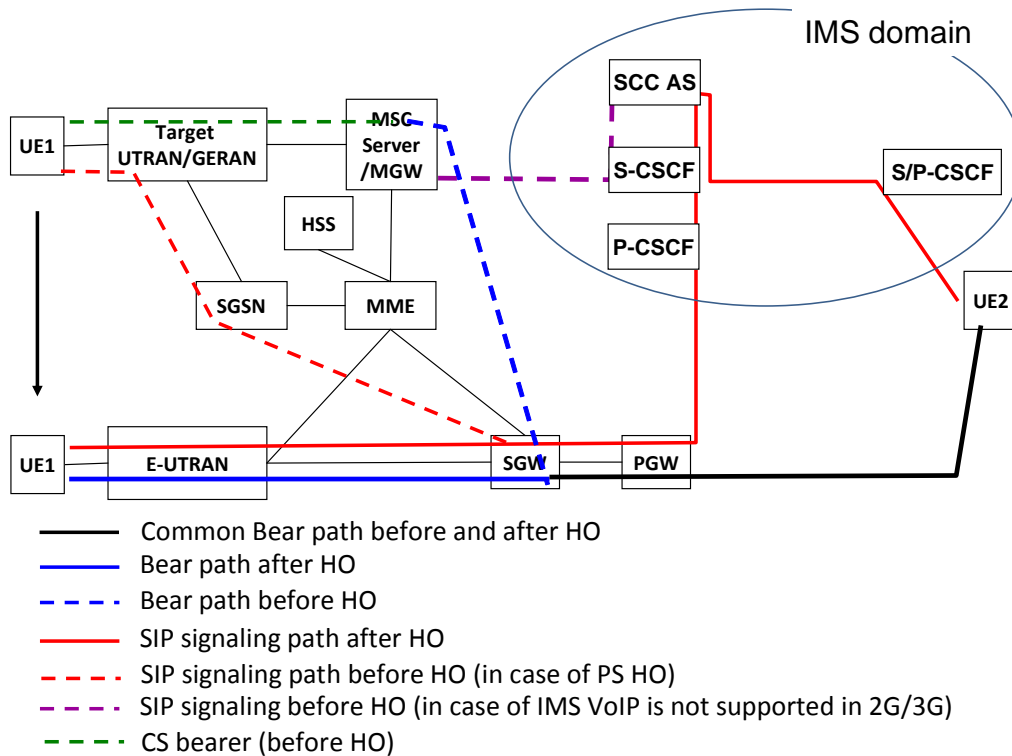

Figure 6.4.2-1: rSRVCC solution using local anchoring

Editor's Note: The architecture figure will include the PCRF.

6.4.2 Information flows

6.4.2.1 Initial ATTACH / TA update procedure

The E-UTRAN attach procedure for 3GPP rSRVCC UE is performed as defined in TS 23.216 [7] with the following additions:

- 1) rSRVCC UE includes the "rSRVCC capability indication" as part of the "MS Network Capability" in the Attach Request message and in Tracking Area Updates.
- 2) If the subscriber is allowed to have rSRVCC in the VPLMN, the HSS shall include the "rSRVCC allowed" indication as part of the subscription data sent to the MME.

6.4.2.2 Call origination procedure in GERAN/UTRAN

In case rSRVCC capable UE determines to establish rSRVCC call, the following procedure takes place.

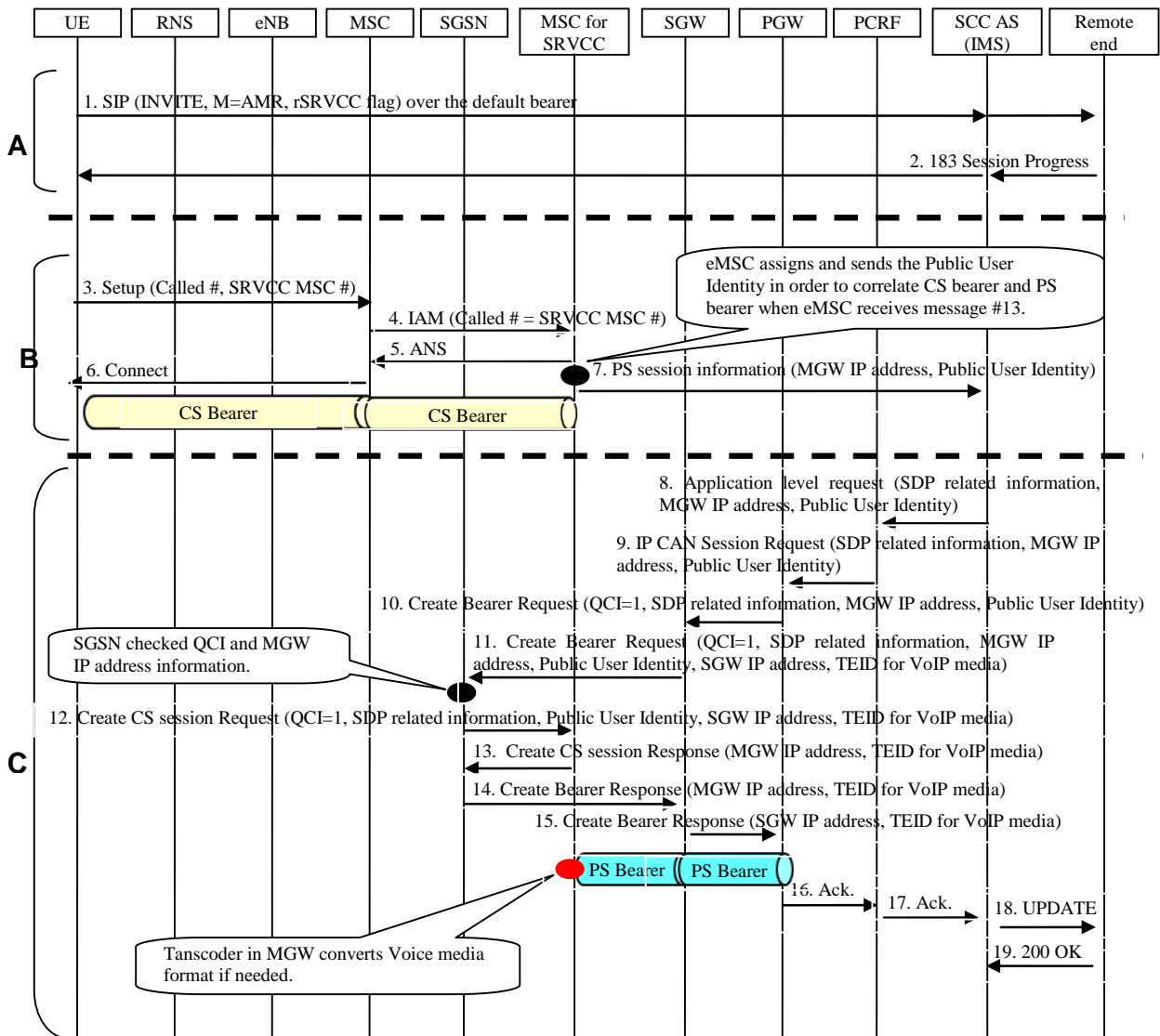

Figure 6.4.2.2-1: Call origination procedure in GERAN/UTRAN

NOTE: Steps in A and B can be performed in parallel. Steps in C is triggered by SCC AS after completing both steps A and B.

1. UE sends the INVITE message with the rSRVCC flag in SIP header if UE wishes to perform HO to IMS in case it would be necessary during a call.
2. When SCC AS receives the 183 Session Progress message from peer end, SCC AS checks the rSRVCC flag. If eSRVCC flag is active, then SCC AS waits for the step 7 to arrive and initiate step 8.
3. UE sends the setup message over the NAS signal. This message triggers the establishment of the CS bearer from UE to MSC for SRVCC via MSC. This setup message has the SRVCC MSC number in order to reach to the MSC Server/MGW enhanced for SRVCC. Alternatively, called number with prefix could also route to the MSC Server/MGW enhanced for SRVCC. This step can be initiated parallel with the step 1.
4. MSC sends the IMS message to the MSC Server/MGW enhanced for SRVCC.
5. The MSC Server/MGW enhanced for SRVCC sends ANSWER message to MSC.
6. The MSC sends connect message to UE. The voice path in the CS domain is established at this point. The MGW waits the Create CS Session Request message (Step 10) to come if the MGW has not received the Create CS Session Request message.

7. The MSC Server/MGW enhanced for SRVCC sends the PS session information to the SCC AS. This message contains the MGW IP address information and the Public User Identity. The MGW IP address is used in SGSN to contact to the right MGW that terminates the voice path in CS domain. The MSC Server/MGW enhanced for SRVCC assigns the SRVCC specific Public User Identity as the similar way as the ICS enhanced MSC server as described in the 3GPP TS 23.292 [3].
8. Once SCC AS receives the 183 Session Progress message, SCC AS send Application level request to the PCRF in order to reserves the network resources for VoIP communication. This message carries the SDP related information, the MGW IP address information and the Public User Identity.
9. The PCRF sends the IP CAN Session request message to the PGW in order to enforce a PCC rule. This message carries the SDP related information, the MGW IP address information and the Public User Identity.
10. The PGW sends the Create Bearer Request message to the SGW. This message carries the SDP related information, the MGW IP address information and the Public User Identity.
11. The SGW sends the Create Bearer Request message to the SGSN. In addition to the SDP related information, the MGW IP address information and the Public User Identity, SGW adds the IP address and TEID for VoIP communication.
12. If the MGW IP address is included in the Create Bearer Request message, the SGSN sends the Create CS Session Request message to the MGW using the MGW IP address received in the step 11. This message carries the SGW IP address, TEID, SDP related information and the Public User Identity. The MGW correlates with the CS voice path that is made by stem 3 to 6 by using the Public User Identity. The SDP related information includes codec related information, routing information to the remote end, etc. The codec related information is used when MGW performs a voice media transcoding.
13. The MGW sends the Create CS session response to the SGSN. This message carries the MGW IP address and TEID to be used for VoIP communication.
14. The SGSN sends the Create bearer response to the SGW. This message carries the MGW IP address and TEID to be used for VoIP communication between the MGW and the SGW.
15. The SGW sends the Create bearer response to the PGW.
16. The PGW sends the acknowledge message to the PCRF.
17. The PCRF sends the acknowledge message to the SPCC AS
18. Once SCC AS receives the Acknowledge message in step 15. The SCC AS sends the UPDATE message to the remote end to inform that all necessary resources has been allocated.
19. The remote end send 200 OK for reply to the message in step 16.

6.4.2.3 Call termination procedure in GERAN/UTRAN

In case rSRVCC capable UE determines to establish rSRVCC call, the following procedure takes place.

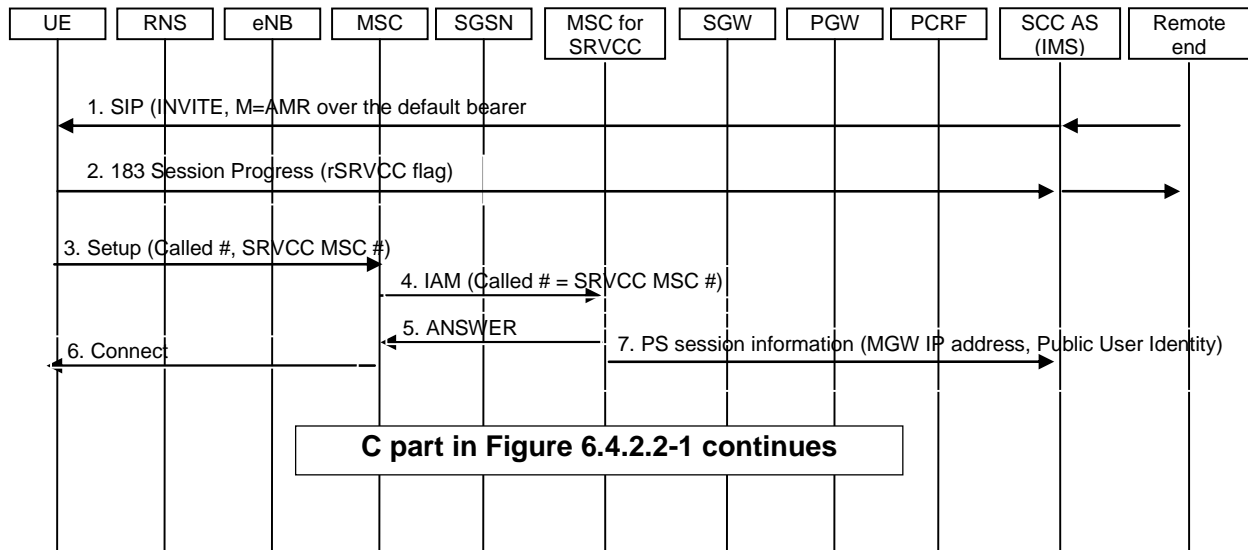

Figure 6.4.2.3-1: Call termination procedure in GERAN/UTRAN

1. UE receives the INVITE message.
2. If UE wishes to perform HO to IMS in case it would be necessary during a call, UE sends the 183 Session Progress message with the rSRVCC flag in SIP header. When SCC AS receives the 183 Session Progress message from UE, SCC AS checks the rSRVCC flag. If rSRVCC flag is active, then SCC AS initiates step 8 in the Figure 6.4.2.2-1 after waiting for step 7 arrived.
3. UE sends the setup message over the NAS signal. This setup message has the SRVCC MSC number in order to reach to the MSC Server/MGW enhanced for SRVCC. Alternatively, called number with prefix could also route to the MSC Server/MGW enhanced for SRVCC. This step can be initiated parallel with the step 1.
4. MSC sends the IMS message to the MSC Server/MGW enhanced for SRVCC.
5. The MSC Server/MGW enhanced for SRVCC sends ANSWER message to MSC.
6. The MSC sends connect message to UE. The voice path in the CS domain is established at this point. The MGW waits the Create CS Session Request message (Step 10) to come if the MGW has not received the Create CS Session Request message.
7. The MSC Server/MGW enhanced for SRVCC sends the PS session information to the SCC AS. This message contains the MGW IP address information. The MGW IP address is used in SGSN to contact to the right MGW that terminates the voice path in CS domain.

After step 7, The C part in the Figure 6.4.2.2-1 continues.

6.4.2.4 SRVCC handover from UTRAN or GERAN to LTE

This procedure is basically same as the UTRAN to E-UTRAN Inter RAT HO procedure as described in TS 23.401 [5]. The deltas are indicated in RED font in the Figure 6.4.2.4-1.

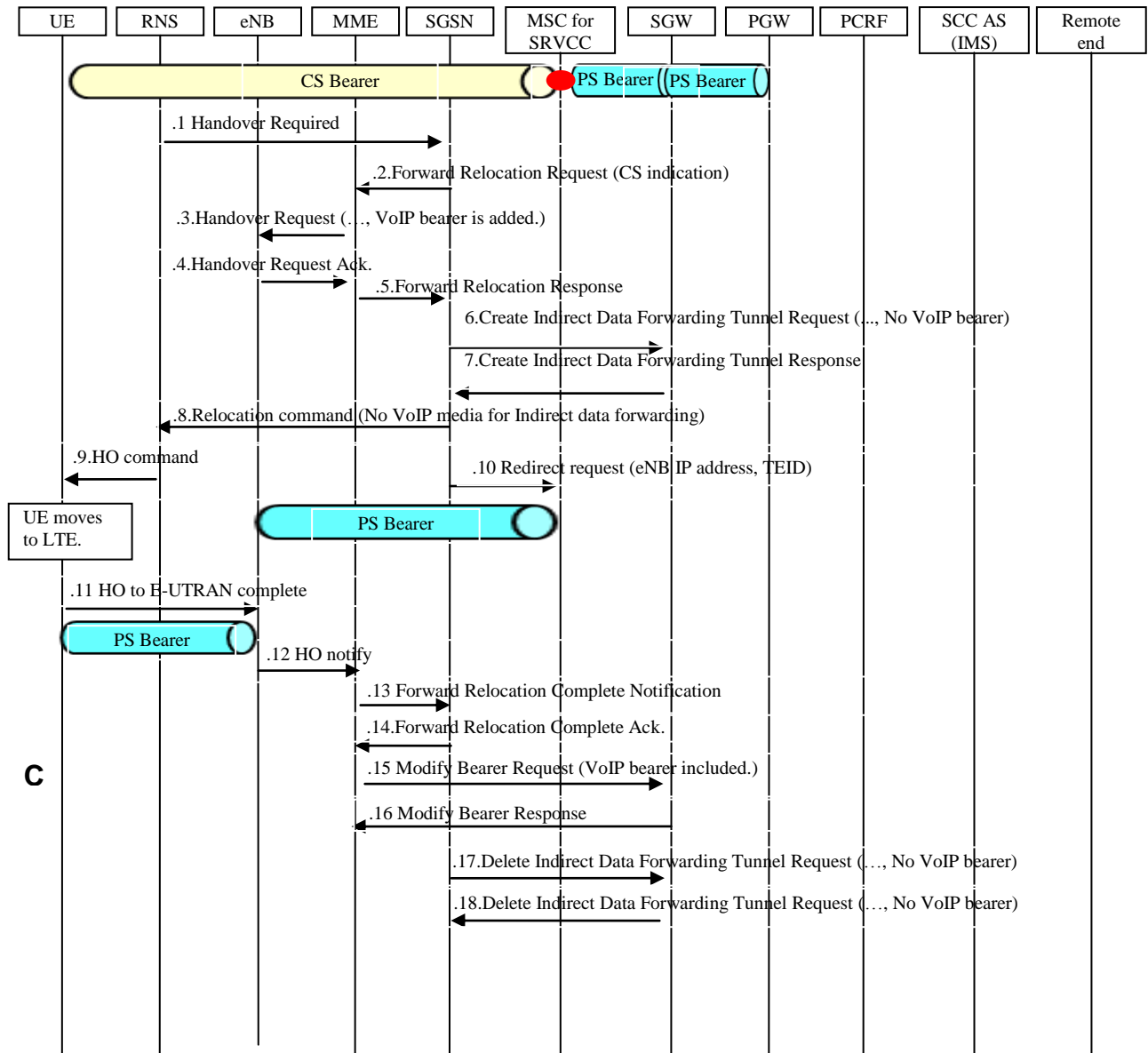

Figure 6.4.2.4-1: SRVCC handover from UTRAN or GERAN to LTE

1. Depending on the radio condition, RNS sends the Handover Required message to SGSN. Note that RNS does not send the Handover Required message to MSC since there is no CS domain available in the LTE.

Editor's Note: How RNS decides to send Handover Required message to SGSN is FFS.

2. SGSN sends the Forward Relocation Request message to the MME with the CS indication. The CS indication indicates that the Voice media exists in CS domain and needs to be handed over the LTE.
3. MME sends the Handover Request message to eNB. eNB reserves all necessary bearer resources including a bearer resources for the VoIP media.

Editor's Note: Voice bearer is created by the separate bearer establishment procedure and the detail is FFS.

4. eNB sends the Handover Request Ack message to the MME.
5. MME sends the Forward Relocation Response message to the SGSN. This message contains the eNB IP address and TEID for VoIP media.
6. MME sends the Create Indirect Data Forwarding Tunnel Request message to the SGW. This message does not create the indirect data tunnel for VoIP media since indirect data forwarding is not performed for VoIP media.
7. SGW sends the Create Indirect Data Forwarding Tunnel Response message to the MME.

8. SGSN sends the Relocation command message to the RNS to command hand over to the LTE.
9. RNS sends HO command to the UE.
10. SGSN sends the Redirect request to the MSC Server/MGW enhanced for SRVCC. This message contains the eNB IP address and TEID that to be used for VoIP media. This message can be sent after the SGSN receives the Forward Relocation Response message from MME. When the MSC Server/MGW enhanced for SRVCC receives this message, the MSC Server/MGW enhanced for SRVCC starts sending DL voice data to the eNB. The MSC Server/MGW enhanced for SRVCC may optionally bi-cast DL voice to both MSC and eNB.

The MSC Server/MGW enhanced for SRVCC starts the release procedure toward the CS domain after a configurable time has passed. This process is not shown in this flow.
11. After UE tunes to the LTE, UE sends the HO to E-UTAN complete message to the eNB.
12. eNB sends HO notify to the MME.
13. MME sends the Forward Relocation Complete Notification message to the SGSN.
14. SGSN sends the Forward Relocation Complete Ack message to MME.
15. MME sends the Modify Bearer Request to the SGW. This message includes the eNB TEID for VoIP media.
NOTE: eNB TEID information is already available at step 4.
16. SGW sends the Modify Bearer Response to the MME.
17. SGSN sends the Delete Indirect Data Forwarding Tunnel Request to the SGW. This message does not include the bearer information for VoIP media.
18. SGW sends the Delete Indirect Data Forwarding Tunnel Response to the SGSN.

6.5 Solution 5: IMS procedure is initiated by MSC Server to ATCF

6.5.1 Architecture Reference Model

6.5.1.1 General

Figure 6.5.1.1-1 provides the reference architecture for reverse SRVCC. The figure only depicts the specific reference points for reverse SRVCC.

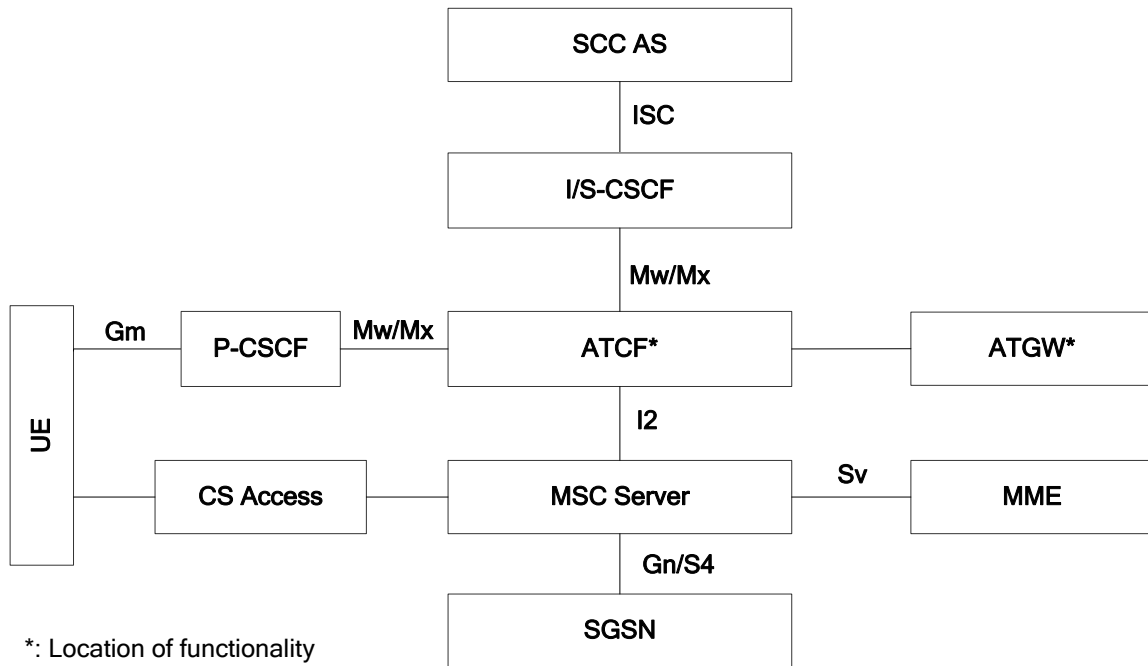

NOTE 1: MSC Server shown in the figure is enhanced for reverse SRVCC

NOTE 2: The MSC server enhanced for reverse SRVCC may not be the source MSC which connects to the source cell.

Figure 6.5.1.1-1: Reference Architecture for reverse SRVCC.

6.5.1.2 Concepts of reverse SRVCC

For facilitating session transfer (reverse SRVCC) of the voice component to the PS domain, the IMS multimedia telephony sessions needs to be anchored in the IMS (ATCF).

For reverse SRVCC from UTRAN/GERAN to E-UTRAN/UTRAN (HSPA), MSC Server enhanced for reverse SRVCC receives the CS handover request of UTRAN/GERAN with the indication that whether PS handover is initiated and this is for reverse SRVCC handling. If PS handover is initiated, the Source SGSN sends PS handover request to the MSC Server enhanced for reverse SRVCC. MSC Server enhanced for reverse SRVCC synchronises the CS and PS handover requests and triggers the CS to PS Handover procedure with the target MME via the Sv reference point. MSC Server enhanced for reverse SRVCC then initiates the session transfer procedure to IMS (ATCF) and coordinates it with the CS to PS Handover SRVCC procedure. Target MME then sends CS to PS handover Response to MSC Server enhanced for reverse SRVCC, which includes all the components information including voice for the UE to access the E-UTRAN/UTRAN (HSPA). After UE tunes to the target access, it initiates the session transfer procedure to IMS (ATCF), and ATCF coordinates the two session transfer procedures.

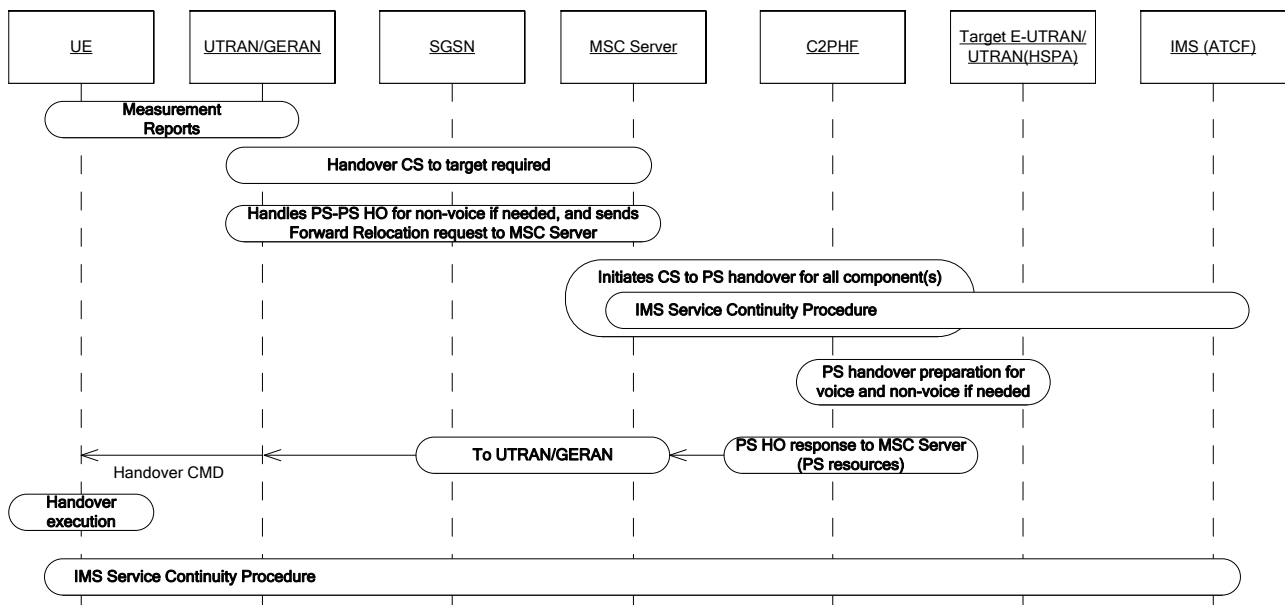

Figure 6.5.1.2-1: Overall high level concepts for reverse SRVCC

6.5.2 Functional Entities

6.5.2.1 ATCF

The ATCF shall be based on the functionality specified in TS 23.237 [4], with the following enhancements:

NOTE 1: For transferring emergency session, the ATCF can be co-located with E-SCC AS.

- Based on operator policy, decide to
 - allocate a STN-rSR;
- Perform the Access Transfer and update the ATGW with the new media path for the new (PS) access leg, without requiring updating the remote leg;
- Make anchoring decision with additional criteria of UE's reverse SRVCC capability;
- Forward the originating call destined to an IMRN pointing to the ATCF;
- Forward the terminating call to CS domain if CS identity is received for the call;
- Inform the MSC Server enhanced for rSRVCC that the Access Transfer is success after response to the Session Transfer message sent by UE;
- Correlate the Session Transfer procedures initiated by the UE and the MSC server enhanced for rSRVCC.

6.5.2.2 SCC AS

The SCC AS shall be based on the functionality specified in TS 23.237 [4], with the following enhancements:

- Clear any existing STN-rSR that has been set to the HSS if a third-party register without a STN-rSR is received;
- Provide the STN-rSR received in a third-party register to the HSS;
- When an ATCF is used, provide during session establishment the PUI registered by the UE to the ATCF;
- If the session is originated from CS domain, instruct the serving network to redirect the call to a number point to the ATCF or instruct the serving network to resend the call via the ATCF, which allocates the STN-rSR;
- Route the call to the ATCF during terminating session establishment if T-ADS selects CS domain.

- Monitor the IMS re-registration of the UE as described in clause 6.5.3.4 and inform the HSS to de-register the UE if needed.

6.5.2.3 S-CSCF

The S-CSCF shall perform IMS Registration procedure for the rSRVCC UE as described in clause 6.5.3.6.

6.5.2.4 MSC Server enhanced for reverse SRVCC

The MSC Server enhance for reverse SRVCC shall be based on the functionality specified in TS 23.216 [7] and TS 23.292 [3], with the following enhancements:

- Perform the session transfer procedure or emergency session transfer procedure from CS to IMS as described in clause 6.5.3.9.1;
- Initiating the CS to PS handover procedure for handover of the voice component to the target cell via the Sv interface and including an emergency indication if this is an emergency session. This procedure is only triggered once regardless of the number of CS sessions those are in use by the UE.
- Coordinating the CS to PS handover and session transfer procedures;
- Not perform MAP_Update_Location procedure for CS to PS handover procedure;
- Synchronize PS handover and CS handover procedures when both procedures are performed.

6.5.2.5 MME

The MME shall be based on the functionality specified in TS 23.401 [5], with the following enhancements:

- Handling the Relocation Preparation procedure requested from MSC Server enhanced for rSRVCC via Sv reference point;
- Perform the bearer reservation procedure for voice media in target access as described in clause 6.5.3.9.2;

6.5.2.6 UE enhanced for reverse SRVCC

The rSRVCC UE shall:

- Indicate to the IMS that the UE is rSRVCC capable when being configured for using IMS speech service supported by the home operator, e.g. the IMS Multimedia Telephony Service for bi-directional speech and the operator policy on the rSRVCC UE as specified in TS 23.237 [4] does not restrict the session transfer.
- Initiate RAU/LAU procedure to indicate the GERAN/UTRAN that the user is allowed to use rSRVCC.
- Initiate a Session Transfer procedure as described in TS 23.237 [4] after handover to the target access is completed.
- Perform IMS Registration procedure as described in clause 6.5.3.6.

6.5.2.7 UTRAN/GERAN

When UTRAN/GERAN selects a target VoIP-capable cell for CS to PS handover, it needs to send an indication to SGSN that this handover procedure requires rSRVCC.

UTRAN/GERAN may be capable of determining the neighbour cell list based on the allowance of rSRVCC and/or presence of CS sessions for a specific UE as described in clause 6.5.3.2.

6.5.3 Message Flows

6.5.3.1 Home control rSRVCC

When the S-CSCF receives IMS registration from a rSRVCC UE, it shall send the rSRVCC subscription information of the user to the UE if it exists. After receiving the rSRVCC subscription information, the UE shall perform RAU/LAU/TAU procedure depends on where it attaches to send an "rSRVCC allowed" indication to the NB/eNB.

6.5.3.2 RAU/LAU/TAU procedure

RAU/LAU/TAU procedure for 3GPP rSRVCC UE is performed as defined in TS 23.060 [6] or TS 23.401 [5] with the following additions:

- NB/eNB receives "rSRVCC allowed" indication as part of the "UE Radio Access Capability". NB/eNB stores this information for rSRVCC operation.

NOTE 1: If the indication is populated by core network, considering not all MSC Server/SGSN need to be enhanced for rSRVCC, if UE initiates CS session with that MSC Server and performs CS handover, this indication will be lost in target NB.

When UE attaches to GERAN/UTRAN, if the "rSRVCC allowed" indication is set to "true" and/or the UE is involved in CS session, then VoIP-capable cells may be included as candidate target cells in the NCL.

NOTE 2: The UE will receive the "rSRVCC allowed" indication via IMS registration procedure.

6.5.3.3 GERAN/UTRAN performs handover procedure

If the GERAN/UTRAN decides to handover the UE with CS session to a VoIP-capable cell, it shall include an rSRVCC indication in the Handover/Relocation Required message for CS handover, and for PS handover if happened, and destine the Handover/Relocation Required message for CS handover to a MSC Server enhanced for rSRVCC.

Annex Y shows an example of how the GERAN/UTRAN packs the rSRVCC indication.

6.5.3.4 Maintaining IMS Registration

During the IMS (re-)registration procedure, The UE shall send a SIP REGISTER request with an additional time interval T_{maintain} to IMS to maintain IMS registration when UE is involved in CS session. The time interval for IMS re-registration is called $T_{\text{Registration}}$. In order not to impact P-CSCF, the T_{maintain} shall be included in the Expires header field of the SIP REGISTER request and the response.

The S-CSCF shall not reduce the T_{maintain} if the 3rd party registration needs to be performed to a SCC AS. The S-CSCF may reduce the $T_{\text{Registration}}$ according to local policy. The S-CSCF shall forward the $T_{\text{Registration}}$ to the SCC AS via 3rd party registration procedure and forward the $T_{\text{Registration}}$ to the UE, e.g. by including the $T_{\text{Registration}}$ in the response to the SIP REGISTER request.

The SCC AS may hold a time interval T_{Transfer} corresponding to the approximate transfer time of the SIP REGISTER request. The SCC AS shall reset the time interval for monitoring IMS re-registration to $(T_{\text{Registration}} + T_{\text{Transfer}})$ when all CS sessions of the UE has been released or the UE re-registration has been informed, and stop monitoring the IMS re-registration when CS session of the UE can be detected. If the time expired, the SCC AS shall inform the HSS to de-register the UE.

6.5.3.5 Preparation of media transfer

UE need to transfer VoIP media right after CS to PS handover procedure described in clause 6.5.3.9.2 is finished. The ATCF and/or MSC Server enhanced for rSRVCC needs to know the IP address and port number used by the UE for receiving media on PS access during CS-PS access transfer. The UE needs to know the IP address, port number and codec for sending media to the ATGW during CS-PS access transfer.

The IP address of the UE is assigned by the network and used for IMS registration procedure. When registering in the IMS, the UE indicates its port number and default codec (or list of codecs) it will receive media on when a transfer is performed. The ATCF can learn this information during IMS registration procedure, and therefore forward the

information, as well as the IP address/port of the ATGW for receiving voice media, to the MSC Server enhanced for rSRVCC during CS-PS access transfer as described in clause 6.5.3.9.

6.5.3.6 Selection of the ATCF

In order to ensure that the MSC Server selects the ATCF during rSRVCC procedure, who may anchor the session, a STPN-rSR (Session Transfer Number for rSRVCC) that can be used by the MSC Server to find the ATCF shall be provided to the serving MSC Server before rSRVCC procedure is triggered.

The ATCF shall allocate the STPN-rSR when the user registers in the IMS. The STN-rSR shall be provided through IMS and via third-party registration to the SCC AS. The SCC AS shall further provide the modified C-MSISDN with prefix of STN-rSR to the HSS, which in turn shall update the serving MSC Server.

NOTE 1: The STN-rSR is not a routable number, and maybe part of the STN-SR. If the SCC AS receives a third-party register without a STPN-rSR, it will remove any prefix of the C-MSISDN.

The following figure shows an example of IMS registration flow where the ATCF provides the STN-rSR to the home network. Existing IMS Registration procedures described in TS 23.228 [11] are used to register the user in IMS.

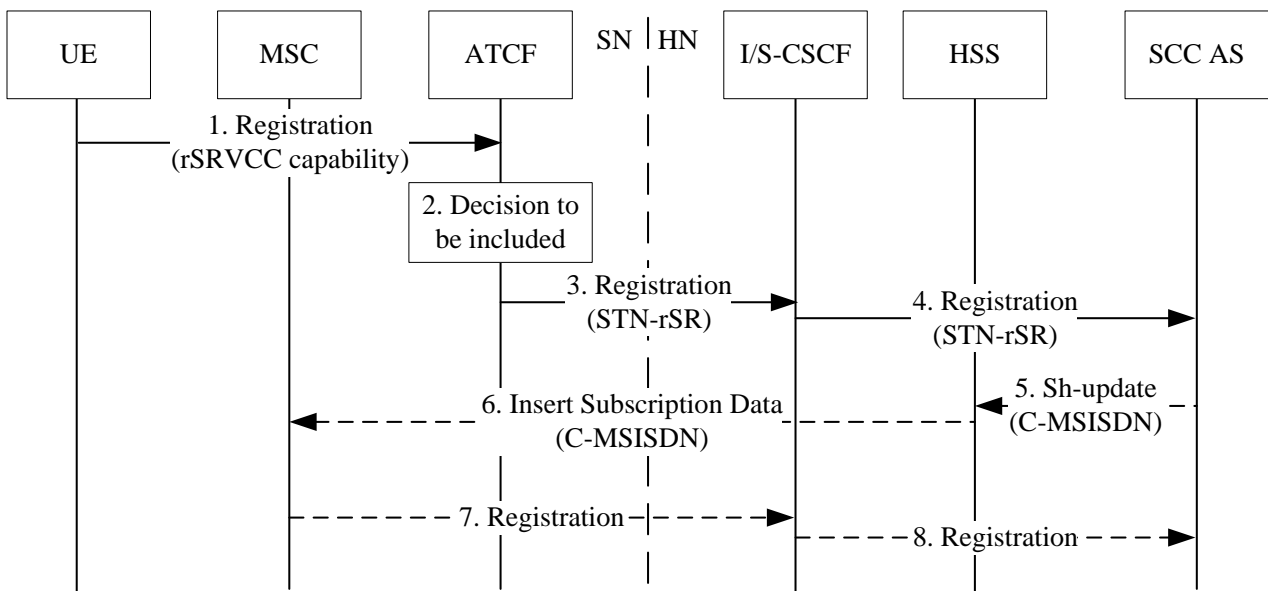

Figure 6.5.3.6-1: IMS Registration

1. UE sends an initial SIP REGISTER request with rSRVCC capability indication to home network via ATCF (P-CSCF not shown in flow). The rSRVCC capability indication is the additional time interval, reserved port, and default codec (or list of codecs).
2. ATCF decides, based on operator policy and in case the home network supports rSRVCC, to allocate a STPN-rSR.
3. The ATCF includes the STN-rSR in the request forwarded to the I/S-CSCF.

NOTE 2: Service level agreements are used to understand whether the home network supports rSRVCC.

4. The I/S-CSCF sends the SIP REGISTER request to the SCC AS according to the third-party registration procedure. The S-CSCF shall forward the rSRVCC subscription information to the UE, e.g. by including this information in the response to the SIP REGISTER request. If the UE receives the information, it shall trigger RAU/LAU/TAU immediately to set the rSRVCC allowed indication to "true".

NOTE 3: In case of multiple registrations from the UE from multiple accesses, the SCC AS will only receive and use a STPN-rSR from an ATCF in the mobile network.

5. SCC AS uses the STN-rSR as the prefix of C-MSISDN and provides the modified C-MSISDN into the HSS.

NOTE 4: If an ATCF does not exist, the SCC AS will remove the prefix of C-MSISDN and provide the modified C-MSISDN in the HSS.

6. If the UE attached in GERAN/UTRAN, HSS provides the STN-rSR as prefix of C-MSISDN to the serving MSC Server because of the change of the subscription data.

7-8.If MSC Server is enhanced for ICS, the MSC Server will perform IMS registration for the UE too, and if the MSC Server also is enhanced for rSRVCC, the SIP REGISTER request may go through the ATCF determined by the STN-rSR.

6.5.3.7 Originating sessions in CS

6.5.3.7.1 Serving MSC Server is not enhanced for ICS

Figure 6.5.3.7.1-1 shows an originating session when the ATCF has previously been included in the signalling path (see clause 6.5.3.6) and serving MSC Server is not enhanced for ICS. If the ATCF was not included in the signalling path then existing Mobile Origination procedures described in TS 23.228 [11] are used.

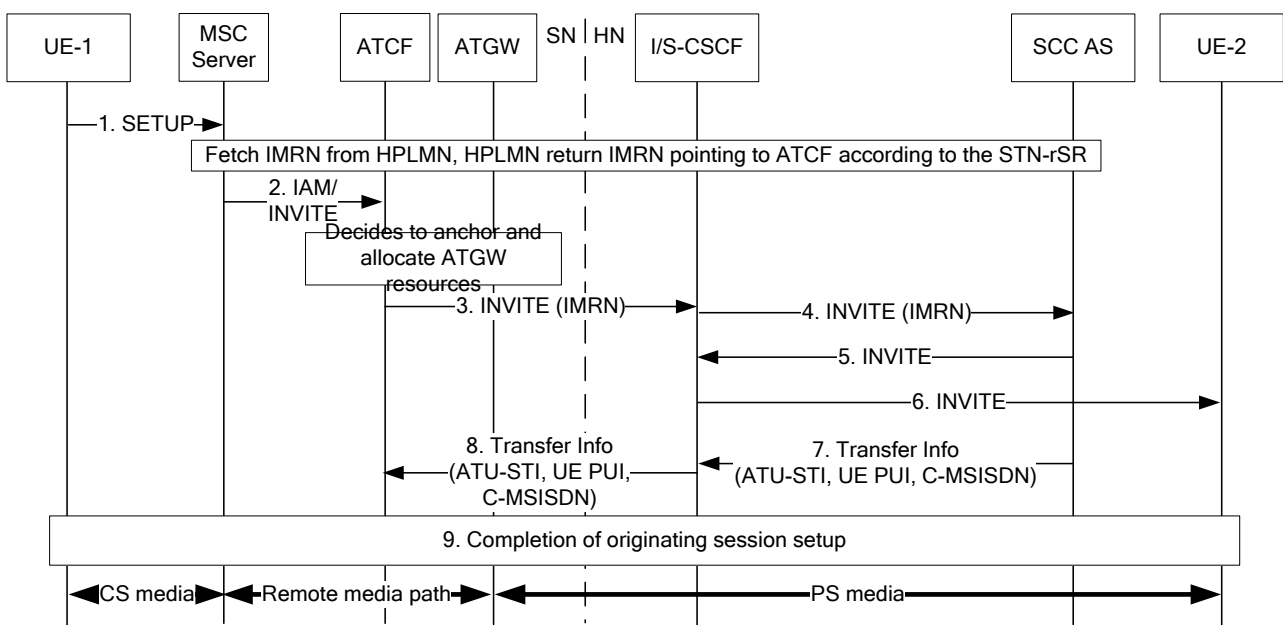

Figure 6.5.3.7.1-1: Originating session that uses only CS media (MSC Server not supporting ICS)

1. UE-1 sends a SETUP message in CS domain to initiate a CS call to UE-2.
2. MSC Server not supporting ICS fetches IMRN from UE-1's home network with terminating number in order to forward the session establishment message to IMS. SCC AS derives an IMRN pointing to the ATCF based on the STN-rSR and roaming agreement. The MSC Server sends an ISUP IAM or SIP INVITE message to the ATCF using the IMRN via a local MGCF.
- 3~4.The ATCF decides to anchor based on local policy and allocates ATGW resources and forwards the SIP INVITE message to the I/S-CSCF of the UE-1's home network. The S-CSCF will forward the SIP INVITE message to the SCC AS according to the originating iFC.
- 5~6.SCC AS changes the request URI of the SIP INVITE request to the terminating number and forwards the SIP INVITE request to the remote UE.
- 7~8. SCC AS sends Access Transfer Info to the ATCF with a dynamic/static ATU-STI, the UE PUI registered by the UE, and the C-MSISDN. The ATCF shall store the Access Transfer Info.

NOTE 1: The Access Transfer Info (step 7 and 8) can be sent as part of the existing session response (step 9) to the INVITE.

NOTE 2: The ATU-STI is a routable address pointing to the SCC AS. It could either be dynamically allocated (for each session) or statically allocated (for the SCC AS).

9. Completion of originating session setup.

6.5.3.7.2 Serving MSC Server is enhanced for ICS

Figure 6.5.3.7.2-1 shows an originating session when the ATCF has previously been included in the signalling path (see clause 6.5.3.6) and serving MSC Server is enhanced for ICS. If the ATCF was not included in the signalling path then existing Mobile Origination procedures described in TS 23.228 [11] are used.

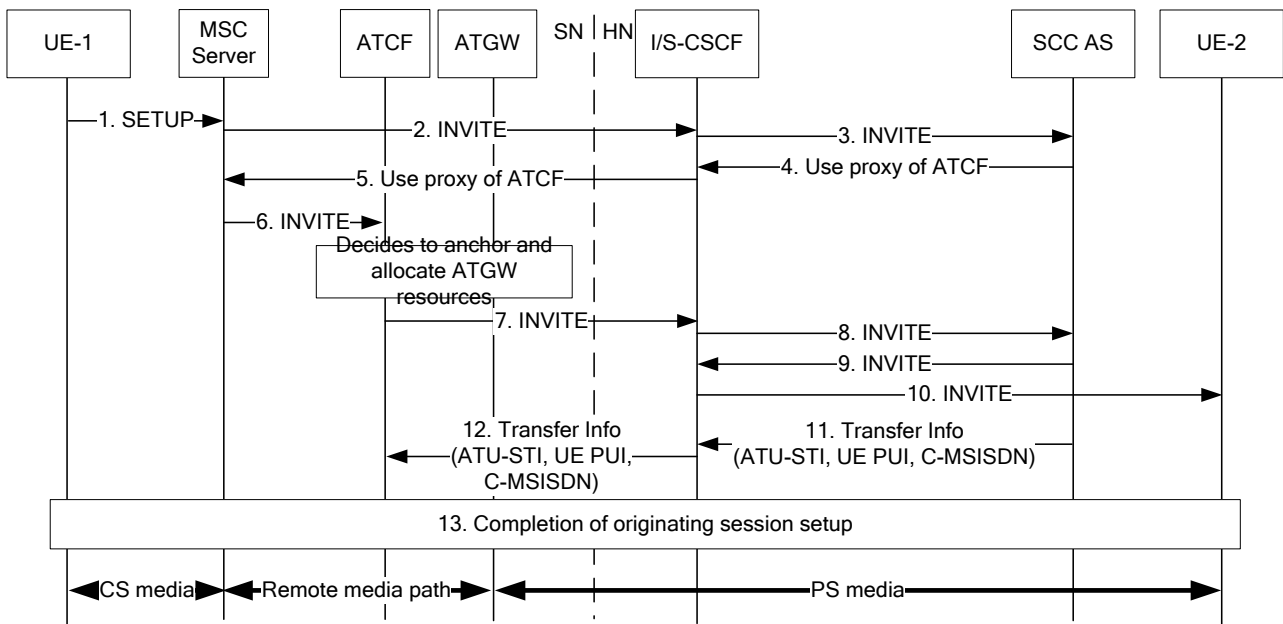

Figure 6.5.3.7.2-1: Originating session that uses only CS media (MSC Server supporting ICS)

1. UE-1 sends a SETUP message in CS domain to initiate a CS call to UE-2.
- 2~3. MSC Server supporting ICS sends an SIP INVITE request to the I/S-CSCF of UE-1's home network, the S-CSCF will forward the SIP INVITE request to the SCC AS according to the originating iFC.
- 4~5. SCC AS determines the ATCF that UE-1 used for IMS registration based on the STN-rSR and roaming agreement. The SIP INVITE does not go through the ATCF, SCC AS informs the MSC Server to re-send the call via the ATCF.
6. The MSC Server re-sends the SIP INVITE request via the ATCF.
- 7~10. The ATCF decides to anchor based on local policy and allocates ATGW resources and forwards the SIP INVITE request to UE-2.
- 11~13. Same as described in step 7~9 of clause 6.5.3.7.1.

6.5.3.7.3 Serving MSC Server is enhanced for rSRVCC

Figure 6.5.3.7.3-1 shows an originating session when the ATCF has previously been included in the signalling path (see clause 6.5.3.6) and serving MSC Server is enhanced for rSRVCC. If the ATCF was not included in the signalling path then existing Mobile Origination procedures described in TS 23.228 [11] are used.

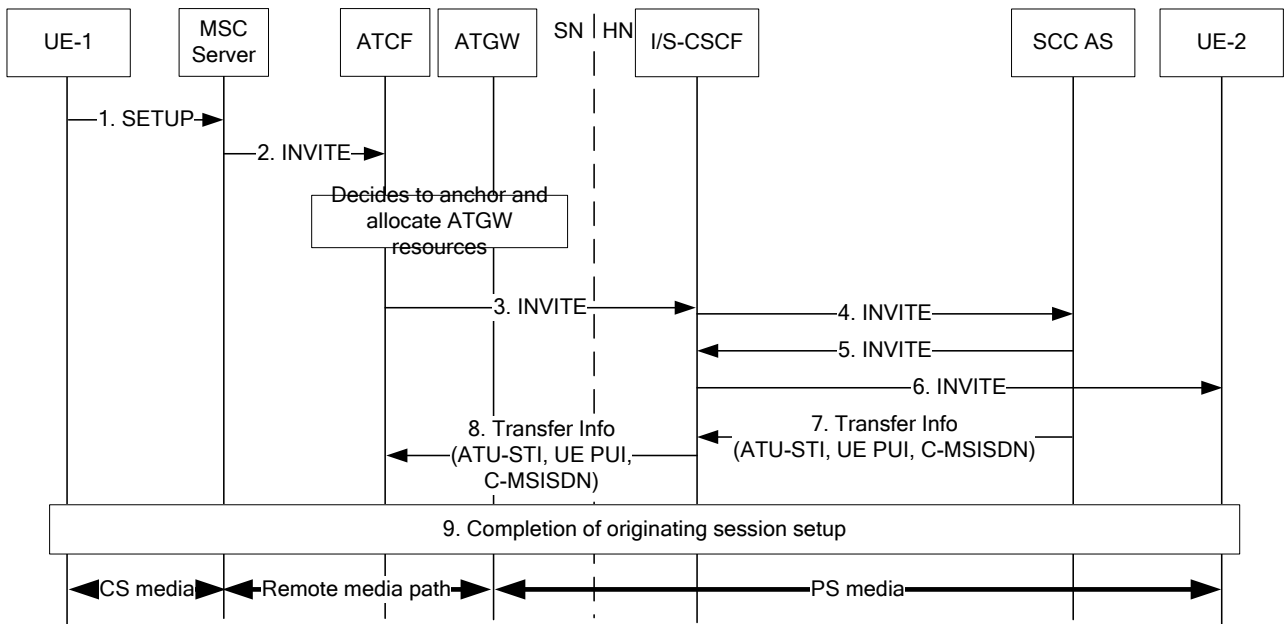

Figure 6.5.3.7.3-1: Originating session that uses only CS media (MSC Server supporting rSRVCC)

1. UE-1 sends a SETUP message in CS domain to initiate a CS call to UE-2.
2. MSC Server supporting rSRVCC sends an SIP INVITE request to UE-2 via the ATCF.
- 3~6. The ATCF decides to anchor based on local policy and allocates ATGW resources and forwards the SIP INVITE request to UE-2.
- 7~9. Same as described in step 7~9 of clause 6.5.3.7.1.

6.5.3.7.4 UE is enhanced for ICS

Figure 6.5.3.7.4-1 shows an originating session when the ATCF has previously been included in the signalling path (see clause 6.5.3.6) and UE is enhanced for ICS. If the ATCF was not included in the signalling path then existing Mobile Origination procedures described in TS 23.228 [11] are used.

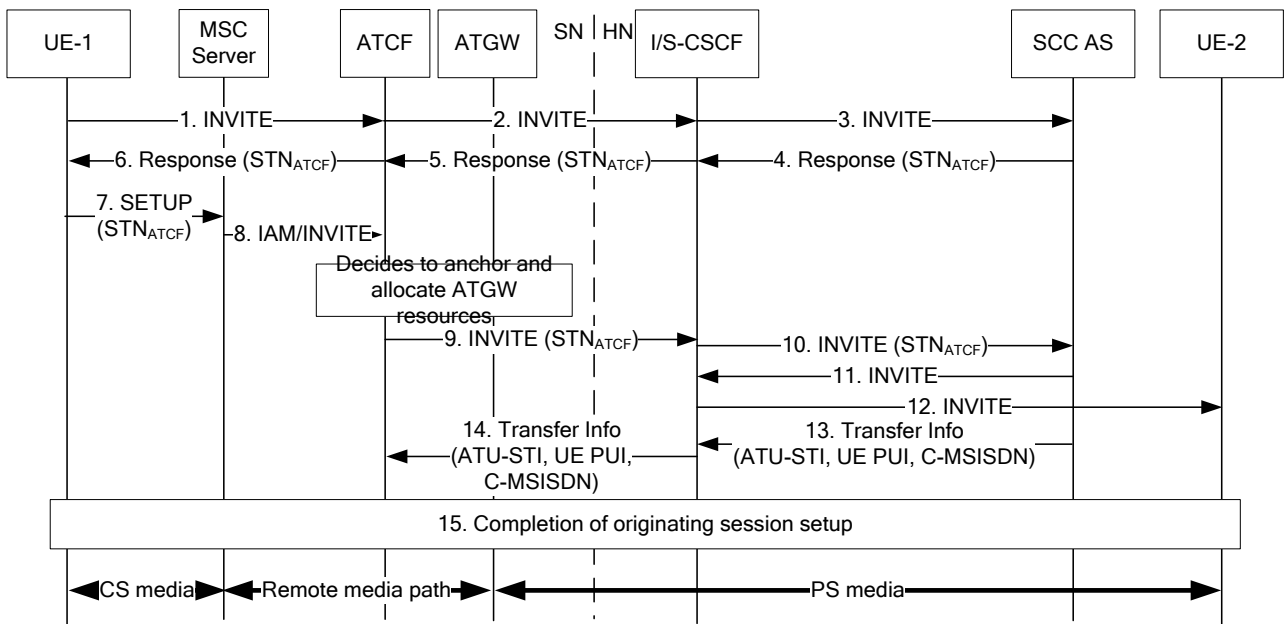

Figure 6.5.3.7.4-1: Originating session that uses only CS media (UE supporting ICS)

- 1~3. UE-1 sends a SIP INVITE message via Gm/I1 interface in PS/CS domain to initiate a call to UE-2. If the SIP INVITE is sent via Gm interface, the SIP INVITE goes through ATCF.
- 4~6. SCC AS determines the ATCF that UE-1 used for IMS registration based on the STN-rSR and roaming agreement. SCC AS derives a dynamic STN pointing to the ATCF and responds to the SIP INVITE request with the dynamic STN to UE-1.
7. UE-1 sends a SETUP message in CS domain destined to the dynamic STN.
8. The MSC Server sends an ISUP IAM or SIP INVITE message to the ATCF using the dynamic STN. If the MSC Server is not enhanced for ICS, the message will be sent to the ATCF via a local MGCF.
- 9~10. The ATCF decides to anchor based on local policy and allocates ATGW resources and forwards the SIP INVITE message to the I/S-CSCF of the UE-1's home network. The S-CSCF will forward the SIP INVITE message to the SCC AS according to the originating iFC.
- 11~15. Same as described in step 5~9 of clause 6.5.3.7.1.

6.5.3.8 Terminating sessions in CS

6.5.3.8.1 UE is not enhanced for ICS

Figure 6.5.3.8.1-1 shows a terminating session when the ATCF has previously been included in the signalling path (see clause 6.5.3.6) and UE is not enhanced for ICS. If the ATCF was not included in the signalling path then existing Mobile Termination procedures described in TS 23.228 [11] are used.

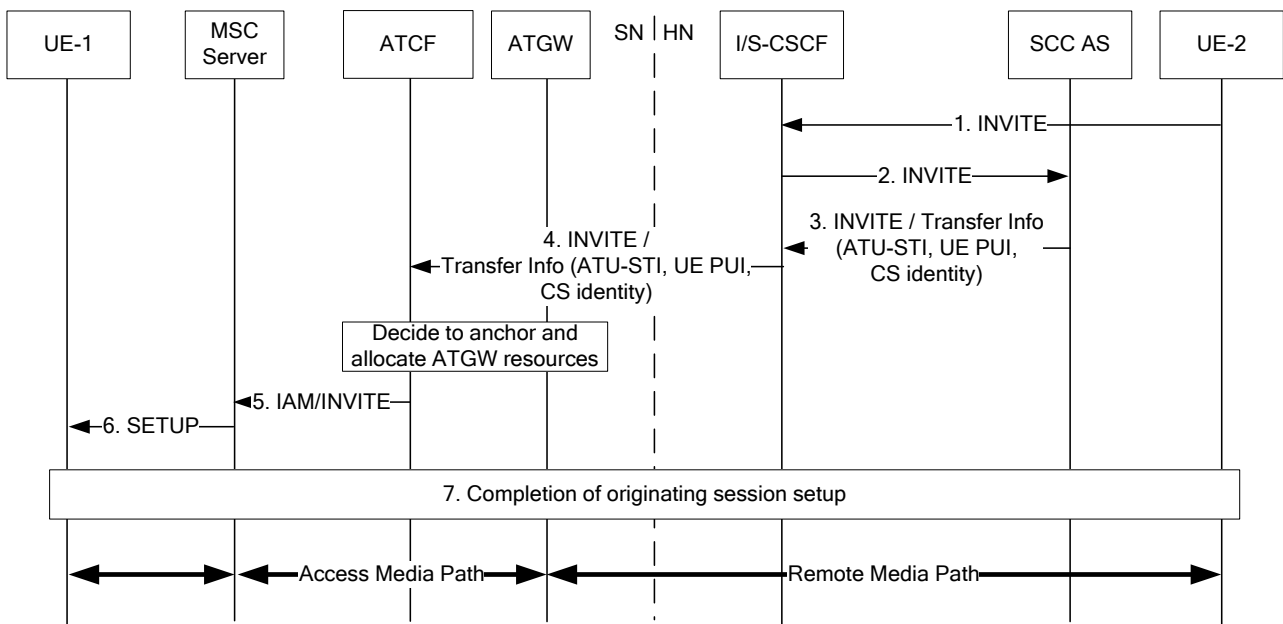

Figure 6.5.3.8.1-1: Terminating session that uses only CS media (UE not supporting ICS)

- 1-2. A Terminating session is sent towards the UE-1 from UE-2. The initial SIP INVITE request is routed via the I/S-CSCF to the SCC AS.
3. The SCC AS performs necessary T-ADS procedures according to TS 23.237 [4]. If the SCC AS knows the ATCF will be in the message path and T-ADS selects CS domain, the SCC AS routes the request towards the UE-1 via PS domain, e.g. destined to the UE PUI registered by the UE-1 itself. The SCC AS sends Access Transfer Info to the ATCF with a dynamic/static ATU-STI, UE PUI, and the CS identity of UE-1. The CS identity of UE-1 includes C-MSISDN, and if the serving MSC Server is enhanced for ICS, the CS identity also may include SIP PUI registered by the MSC Server for the UE-1 and information of serving MSC Server, e.g. contact of the MSC Server.

NOTE 1: The Access Transfer Info can be sent as part of the existing INVITE. If the T-ADS selects PS domain and UE-1 does not support ICS, the Access Transfer Info includes ATU-STI, UE PUI, and C-MSISDN.

4. The INVITE is routed towards the ATCF (P-CSCF not shown in flow). When receiving the SIP INVITE request and CS identity, the ATCF decides to anchor based on local policy, allocates ATGW resources for voice media, anchors the voice media in the ATGW. The ATCF shall store the ATU-STI, the UE PUI, and the C-MSISDN. The ATCF removes the ATU-STI and CS identity from the INVITE.
5. The ATCF forwards the SIP INVITE request to the UE-1 via CS domain using the CS identity. The forwarded SIP INVITE request will go through a local MGCF near the ATCF if C-MSISDN in the CS identity is used.
6. The MSC Server sends a SETUP message to the UE-1.
7. Session setup is completed.

6.5.3.8.2 UE is enhanced for ICS

Figure 6.5.3.8.2-1 shows a terminating session when the ATCF has previously been included in the signalling path (see clause 6.5.3.6) and UE is enhanced for ICS. If the ATCF was not included in the signalling path then existing Mobile Termination procedures described in TS 23.228 [11] are used.

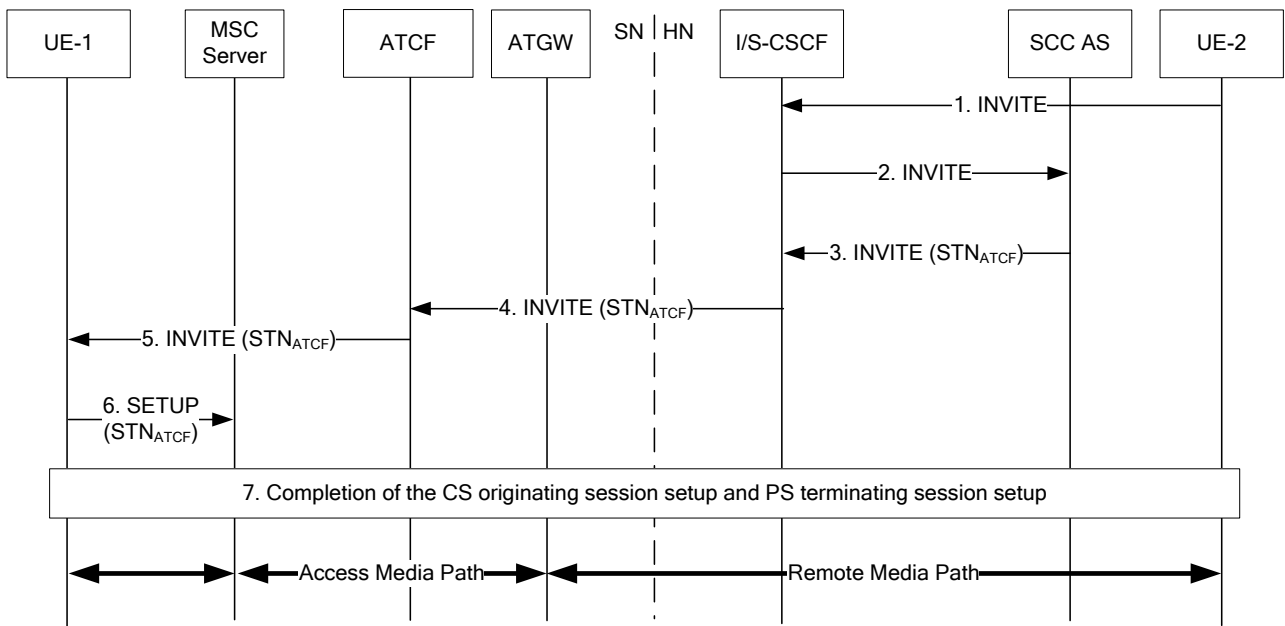

Figure 6.5.3.8.2-1: Terminating session that uses only CS media (UE supporting ICS)

- 1~2. A Terminating session is sent towards the UE-1 from UE-2. The initial SIP INVITE request is routed via the I/S-CSCF to the SCC AS.
- 3~4. The SCC AS determines the ATCF that UE-1 used for IMS registration based on the STN-rSR and roaming agreement. SCC AS derives a dynamic STN pointing to the ATCF and forwards the SIP INVITE request with the dynamic STN to UE-1 as described in TS 23.237 [4].

NOTE 1: The Access Transfer Info can be sent as part of the existing INVITE.

5. The ATCF forwards the SIP INVITE request to the UE-1 without the Access Transfer Info.
6. UE-1 sends a SETUP message in CS domain destined to the dynamic STN.
7. Completion of the CS originating session setup that is same as described in setup 8~15 of clause 6.5.3.9.4, and completion of the PS terminating session setup as described in TS 23.237 [4].

6.5.3.9 CS - PS Access Transfer

6.5.3.9.0 Introduction

This clause describes the main steps of the rSRVCC procedure of the alternative. There are two parallel procedures in the flow: GERAN/UTRAN to E-UTRAN handover procedure and, IMS Service Continuity procedure initiated by MSC Server. The IMS Service Continuity procedure initiated by MSC Server is triggered by HO message of the GERAN/UTRAN to E-UTRAN handover procedure.

6.5.3.9.1 IMS Session Continuity procedure

This clause describes the detail flow of IMS Session Continuity procedure for the CS-PS access transfer.

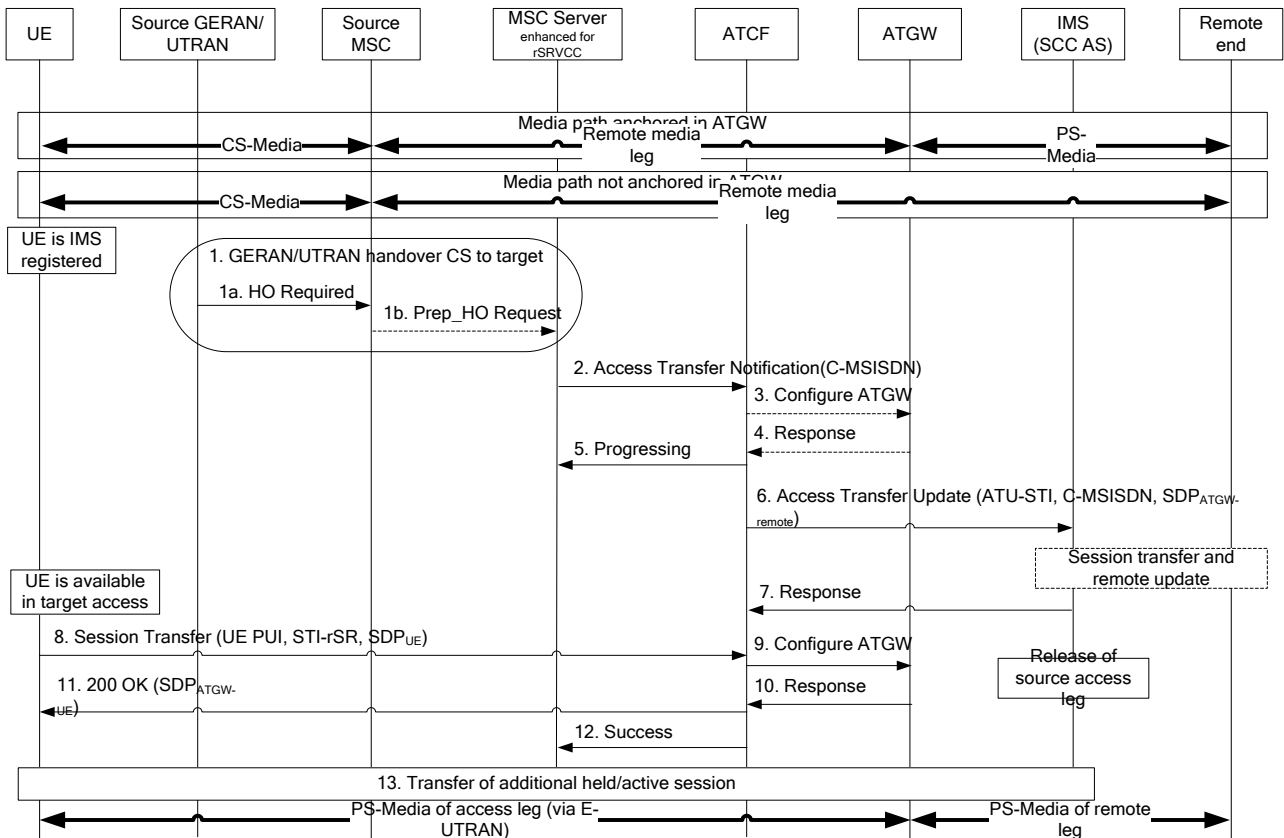

Figure 6.5.3.9.1-1: IMS Session Continuity procedure of rSRVCC

1. Source GERAN/UTRAN determines to perform handover to VoIP-capable cell based on the measurement report and acts as described in clause 6.5.3.3, which will result in the MSC Server enhanced for rSRVCC receiving a handover request from CS domain. If the MSC Server enhanced for rSRVCC is not the Source MSC Server, then the Source MSC Server will send a Prep_HO_Request message to the MSC Server enhanced for rSRVCC.

If the C-MSISDN is not received or does not contain a STN-rSR, the MSC Server enhanced for rSRVCC shall reject the CS handover.

2. The MSC Server initiates Access Transfer Notification message with C-MSISDN to the ATCF that determined by the STPN-rSR in the C-MSISDN, e.g. by sending a SIP INVITE (C-MSISDN) request to the ATCF.
- 3~4. If the voice media of the transferred session has not been anchored in ATGW, the ATCF sends Configure ATGW message to ATGW and gets response from the ATGW to reserve the resource for voice media.
5. The ATCF correlates the Access Transfer Notification message with the transferred session using the C-MSISDN, and informs the MSC Server enhanced for rSRVCC that the access transfer is in progressing, e.g. by sending a SIP "183 Session Progress" response.

The ATCF sends the IP address/port of UE for receiving voice media, the IP address/port of ATGW for receiving voice media, and the codec used to the MSC Server enhanced for rSRVCC in this step.

6. The ATCF sends Access Transfer Update message with C-MSISDN to the SCC AS using the static ATU-STI. The SCC AS correlates the incoming Access Transfer Update message with the transferred session using the C-MSISDN, and if the Session Description (SDPATGW-remote) has changed, a remote end update is initiated according to existing procedures.
7. The SCC AS response to the Access Transfer Update message and releases the source access leg after a while.
8. When UE-1 handover to the target access, the RRC connection has been ready for data transfer, it sends Session Transfer message to IMS using pre-configured STI-rSR, e.g. by sending a SIP INVITE (UE PUI, STI-rSR) to the IMS.
- 9~10. The Session Transfer message arrives at the ATCF, the ATCF knows that the Session Transfer message is for rSRVCC according to the STI-rSR and correlates the Session Transfer message with the transferred session using the UE PUI. The ATCF sends Configure ATGW message to ATGW and gets response from the ATGW to reserve the resource for voice media and correlates it with the resource reserved in step 3 and 4.
11. The ATCF response to the UE.

NOTE 1: This may cause bearer modification procedure due to the change of QoS and/or TFT for the voice bearer .

12. The ATCF informs the MSC Server enhanced for rSRVCC that the access transfer is successful, e.g. by sending a SIP "200 OK" response.

NOTE 2: After the CS-PS access transfer, the MSC Server enhanced for rSRVCC may release the CS resources immediately instead of waiting for the terminating of access leg.

13. The UE may initiate transfer of any additional held/active session.

6.5.3.9.2 CS to PS handover procedure

This clause describes the detail flow of CS to PS handover procedure for the CS-PS access transfer. The bearer information, Connection Info of ATGW, and Codec are included in Target to Source Transparent Container, e.g. using a NAS message format.

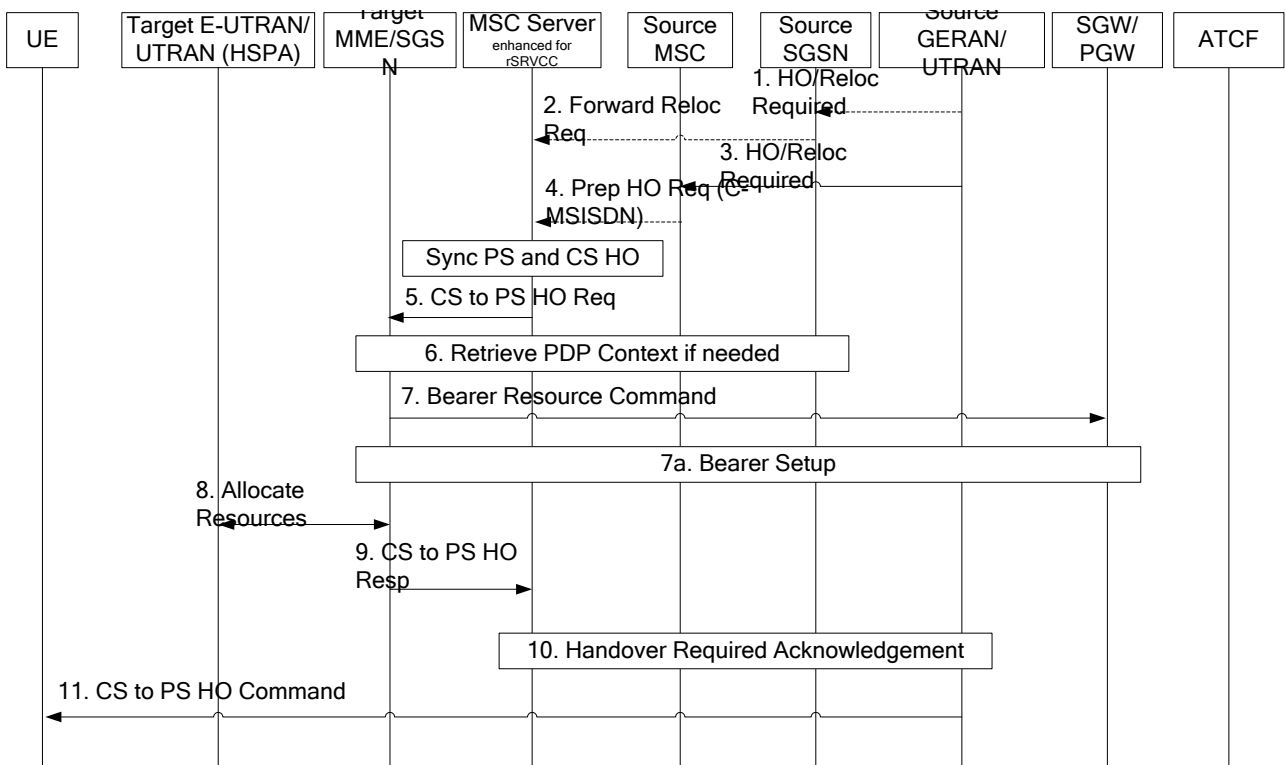

Figure 6.5.3.9.2.1-1: Target MME/SGSN initiate resources reservation

- 1-2. If the UE is active in PS domain, source GERAN/UTRAN acts as described in clause 6.5.3.3 and sends a Handover/Relocation Required (target ID, rSRVCC indication, Source to Target transparent container) message to source SGSN, and source SGSN sends Forward Relocation Request (target ID, rSRVCC indication, Source to Target transparent container) message to MSC Server enhanced for rSRVCC according to the target ID.
- 3-4. Source GERAN/UTRAN acts as described in clause 6.5.3.3 and sends a Handover/Relocation Required (target ID, rSRVCC indication, index of source SGSN, Emergency Indication, Source to Target transparent container) message to source MSC, and if the source MSC is not the target MSC, source MSC performs inter-MSC handover procedure e.g. sends Prepare HO Request (target ID, rSRVCC indication, index of source SGSN, Emergency Indication, C-MSISDN, Source to Target transparent container) message to MSC Server enhanced for rSRVCC according to the target ID.

The index of source SGSN IE shall be included when PS HO is not performed. Otherwise, it shall not be included.

5. MSC Server enhanced for rSRVCC synchronizes the PS and CS handover procedure, i.e. if Forward Relocation Request arrives first, then MSC Server enhanced for rSRVCC waits for the message for CS handover, if the message for CS handover arrives first, then MSC Server enhanced for rSRVCC waits for the Forward Relocation Request message if index of source SGSN IE is not included. MSC Server enhanced for rSRVCC sends CS to PS HO Request (IMSI, source SGSN Info, Connection Info of UE, Connection Info of remote, Codec, Non-voice Bearers Context, target ID, Source to Target transparent container, Emergency Indication) message to target MME/SGSN.

The Non-voice Bearers Context IE is included only when PS-PS HO is performed. The Source SGSN Info IE shall be included when PS-PS HO is not performed. The target ID is understandable by target access network. The Codec can be used by the target MME/SGSN to determine the QoS of the voice bearer.

6. If PS-PS HO is not performed, the target MME/SGSN retrieves PDP context from Source SGSN as described in TS 23.401 [5].
7. Target MME/SGSN sends Bearer Resource Command to initiate the bearer setup procedure.
8. Target MME/SGSN allocates resources in UTRAN/E-UTRAN.
9. Target MME/SGSN sends CS to PS HO Response message to the MSC Server enhanced for rSRVCC.
10. The MSC Server enhanced for rSRVCC complete the handover preparation procedures.

NOTE 2: The ATGW can for a certain period of time send media both on the source access leg and the new target access leg to minimize the interruption delay further.

11. Source GERAN/UTRAN sends Handover Command message to UE, indicating CS to PS handover. This may include additional information such as the IP address/port the UE shall send the media to, and codec used.

NOTE 3: After completion of CS to PS handover, the UE can start sending and receiving voice using the PS voice bearer.

6.5.3.9 Failure to complete CS-PS Access Transfer

In case of failure before MSC Server initiates IMS Service Continuity procedure, there is no difference to TS 23.060 [6].

In case of failure after UE receives HO command or in case of handover cancellation, the MSC Server enhanced for rSRVCC will receive information from source access, the MSC Server enhanced for rSRVCC shall send an Access Transfer Cancel message to the ATCF, e.g. by sending a SIP CANCEL request. If the ATCF has sent an Access Transfer Update, the ATCF shall re-establish the source media path, e.g. using 3PCC procedure, and send an Access Transfer Failure message to the SCC AS, e.g. by sending a SIP BYE request with indication that the access transfer is fail. After receiving the Access Transfer Failure message, the SCC AS shall not release the source access leg.

7 Assessment of the solutions

7.1 Assessment Criteria

The criteria include:

- Voice interruption not exceeding 300ms, in roaming and non-roaming scenarios;
- Minimal impacts on the networks;
- Additional network resource consumption in UE/IMS;
- Call set up delay due to rSRVCC.

7.2 Assessment of the solution 3+5 access transfer preparation alternatives

The following table summarizes the impacts on the different nodes of the existing alternatives for the access transfer preparation in solution 3+5 ("Media anchoring in serving network with Access Transfer Control Functionality").

	Node impacts of the voice bearer establishment procedure	UE	MSC	SGSN / MME	ATCF / P-CSCF	SGW / PGW	PCRF
Alternative 1		1- Indicate the preallocated ports and codecs in the Registration procedure. 2- Receive the voice bearer info and the codec info in the Handover command from the MSC, and set up the PS bearer as a result of that message. 3- Start using the voice bearer right after the rSRVCC handover. 4- Trigger service continuity procedure once on E-UTRAN.	1- Receive rSRVCC HO request. 2- Send rSRVCC HO request to source SGSN/MME. 3- Send voice bearer setup request to ATCF. 4- Receive HO response from source SGSN/MME. 5- Send HO Command including the voice bearer/selected codec to UE. 6- Send switch media indication to ATCF.	1- Receive rSRVCC HO request from MSC (and possibly from RAN). 2- Wait for Create Bearer Request or Downlink Data Notification with rSRVCC indication from SGW. 3- Trigger relocation. 4- Send rSRVCC HO response to MSC, including voice bearer information.	ATCF: 1- Store UE ports & codec info. 2- Receive message from MSC and relay it to P-CSCF indicating that this is for rSRVCC. If P-CSCF not collocated with ATCF: 1- Receive message from ATCF and trigger voice bearer setup towards PCRF indicating that this is for rSRVCC.	1- SGW / PGW: pass the rSRVCC indication through. 2- SGW impact for ISR: if no S1-U exists when the SGW receives the Create Bearer Request for rSRVCC, send a Downlink Data Notification indicating this is for rSRVCC.	1- Trigger voice bearer establishment, including indication that this is for rSRVCC. 2- Correlate the service continuity request from the UE with the voice bearer already established.
Alternative 2		1- Indicate the preallocated ports and codecs in the Registration procedure. 2- Receive the voice bearer info and the codec info in the Handover command from the MSC, and set up the PS bearer as a result of that message. 3- Start using the voice bearer right after the rSRVCC handover. 4- Trigger service continuity procedure once on E-UTRAN.	1- Store UE ports and codec info. 2- Receive rSRVCC HO request. 3- Send rSRVCC HO request to SGSN/MME including info regarding the local & remote ports/codec to be used. 4- Receive HO response from SGSN/MME. 5- Send HO Command including the voice bearer/selected codec to the UE. 6- Send switch media indication to ATCF.	1- Receive rSRVCC HO request from MSC (and possibly from RAN). 2- Trigger Voice bearer setup towards SGW based on the local & remote ports/codec received from MSC. 3- Trigger relocation. 4- Send rSRVCC HO response to MSC, including voice bearer information	-	-	1- Correlate the service continuity request from the UE with the voice bearer already established.
Alternative 3		1- Trigger the pre-establishment of the voice bearer after IMS	1- Receive rSRVCC HO request. 2- Send rSRVCC HO	Source side: 1- Accept Create Bearer Request from SGW for	ATCF: 1- Receive message from UE and relay it to P-	1- Receive an indication from the PCRF to setup a suspended	1- Trigger voice bearer establishment, including indication

<p>registration or after rSRVCC handover.</p> <p>2- Receive the voice bearer info and the codec info in the Handover command from the MSC, and set up the PS bearer as a result of that message.</p> <p>3- Start using the voice bearer right after the rSRVCC handover.</p> <p>4- Trigger service continuity procedure once on E-UTRAN.</p>	<p>request to source SGSN/MME.</p> <p>3- Receive HO response from source SGSN/MME.</p> <p>4- Send HO Command including the voice bearer to UE.</p> <p>5- Send switch media indication to ATCF.</p>	<p>the voice bearer without allocating radio resources for it.</p> <p>2- Deal with mobility with the suspended voice bearer.</p> <p>3- Receive rSRVCC HO request from MSC (and possibly from RAN).</p> <p>4- Trigger relocation.</p> <p>5- Send rSRVCC HO response to MSC, including voice bearer information.</p> <p>Target side:</p> <p>1- Receive a relocation request indicating that the suspended voice bearer shall become active.</p> <p>2- Activate the voice bearer at successful SRVCC.</p>	<p>CSCF indicating to set up a voice bearer for rSRVCC.</p> <p>If P-CSCF not collocated with ATCF:</p> <p>2- Receive message from ATCF and trigger voice bearer setup towards PCRF indicating that this is for rSRVCC.</p>	<p>voice bearer (while other PS bearers are not suspended).</p> <p>2- Deal with a new indicator about the status of a bearer – whether it should be in active or suspended status at Modify Bearer Request.</p>	<p>that this is for rSRVCC.</p> <p>2- Correlate the service continuity request from the UE with the voice bearer already established.</p>
<p>1- Trigger the pre-establishment of the non GBR bearer to be used temporarily for voice after IMS registration.</p> <p>2- Start using the QCI-7 bearer right after the rSRVCC handover.</p> <p>3- Trigger service continuity procedure once on the target access.</p> <p>4- Switch to using the QCI-1 bearer for voice when it has been established.</p>	<p>1- Receive rSRVCC HO request.</p> <p>2- Send rSRVCC HO request to target SGSN/MME.</p> <p>3- Receive HO response from target SGSN/MME.</p> <p>4- Send switch media indication to ATCF.</p>	<p>Target side:</p> <p>1- Coordinate the PS handover request from source SGSN or with CS to PS handover request from MSC.</p>	<p>ATCF:</p> <p>1- Receive message from UE and relay it to P-CSCF indicating to set up a voice bearer for rSRVCC.</p> <p>If P-CSCF not collocated with ATCF:</p> <p>2- Receive message from ATCF and trigger voice bearer setup towards PCRF indicating that this is for rSRVCC.</p>	<p>TBC</p>	<p>TBC</p>

Based on that summary, the following benefits/drawbacks of the different solutions can be listed:

	Alternative #1	Alternative #2	Alternative #3	Alternative #4
Benefits	<ul style="list-style-type: none"> - Does not require resource allocation prior to an rSRVCC handover. - Only the SGSNs (and MMEs in case of GERAN with no DTM support) in areas where rSRVCC can take place need to be enhanced. - Avoids the need for transcoding after rSRVCC. 	<ul style="list-style-type: none"> - Does not require resource allocation prior to an rSRVCC handover. - Only the SGSNs (and MMEs in case of GERAN with no DTM support) in areas where rSRVCC can take place need to be enhanced. - Avoids the need for transcoding after rSRVCC. 	<ul style="list-style-type: none"> - Does not prolong the handover procedure. 	<ul style="list-style-type: none"> - Only MME in areas where rSRVCC can take place need to be enhanced. - Does not prolong the handover procedure.
Drawbacks	<ul style="list-style-type: none"> - Prolongs the handover procedure. - Has ATCF/P-CSCF impacts. - Has SGW impact. 	<ul style="list-style-type: none"> - Prolongs the handover procedure. - SGSN impact: the SGSN needs to decide how to map the codec/port information received from the MSC to TAD and requested QoS. 	<ul style="list-style-type: none"> - Requires resource allocation for each rSRVCC capable UE even in the case when no rSRVCC will ever take place. - Requires that all MME/SGSN be enhanced to support the pre-establishment of the voice bearer without allocating radio resources for it. - Has ATCF/P-CSCF impacts. - PGW/SGW impact: requires from the PGW/SGW that they are able to deal with one suspended bearer while other non-suspended bearers exist. - Has an impact on the existing mobility procedures (including SRVCC): requires from the MME/SGSN that they are able to deal with the suspended bearer in the mobility procedures. - As the codec is selected long before the rSRVCC handover, the likelihood that transcoding is required (at least temporarily) after rSRVCC handover is high. 	<ul style="list-style-type: none"> - Requires resource allocation for each rSRVCC capable UE even in the case when no rSRVCC will ever take place. - As the codec is selected long before the rSRVCC handover, the likelihood that transcoding is required (at least temporarily) after rSRVCC handover is high. - Unclear how much improvement the use of a non GBR bearer for transporting voice together with transcoding (in most cases) will bring compared to a voice break. - MME impact: requires that the MME coordinates the PS handover request from source SGSN or with CS to PS handover request from MSC

8 Conclusion

8.1 General

As an intermediate conclusion, it was agreed at SA WG2#81, to pursue a combination of the current solutions 3 and 5 as a way forward (see clause 6.3).

All MSC Servers where rSRVCC is supported need to be enhanced for rSRVCC.

8.2 Access Transfer preparation / How to reserve bearer for VoIP

As an intermediate conclusion, it was agreed at SA WG2#84, to pursue alternatives 1 and 2 (clauses 6.3.3.7.1 and 6.3.3.7.2), that minimize resource consumption in the network compared to solutions 3 and 4 (clauses 6.3.3.7.3 and 6.3.3.7.4) which minimize handover preparation time.

As a final conclusion, it was agreed at SA WG2#86, to select Alternative 5 (clause 6.3.3.7.5) as the recommended solution for Access Transfer preparation.

8.3 Source SGSN selection by MSC Server

The Alternative 1 "CN nodes based" documented in clause 6.3.3.9.1 is not further considered.

The Alternative 2 "UE and/or RAN provided information" documented in clause 6.3.3.9.2 is selected.

8.4 Maintaining IMS registration over PS access during the CS session

Solution 1 ("ATCF controlled registration") and solution 2 ("SCC AS controlled registration") permit to always allow for rSRVCC to take place while the UE is under GERAN without DTM support but have quite large impacts on the network/the UE.

Due to the fact that the situation in which the IMS registration would expire during the CS session is expected to occur pretty rarely, it was decided at SA2 #84 to rather pursue a solution that does not maintain IMS registration but allows to handle gracefully the situations in which the IMS registration has expired.

8.5 Summary

The combination of clause 5 and of the following sub-clauses represents a full solution for Single Radio Voice Call Continuity (SRVCC) from UTRAN/GERAN to E-UTRAN/HSPA, which is recommended for standardization:

- Architecture Reference Model: clause 6.3.1;
- Functional Entities: clause 6.3.2;
- Message flows:
 - clauses 6.3.3.1 to 6.3.3.6,
 - clause 6.3.3.7.5,
 - clause 6.3.3.8,
 - clause 6.3.3.9.2;
- IMS registration Considerations: clauses 6.3.4.1 and 6.3.4.4.

Annex A: Mechanisms to re-enable E-UTRAN capability

A.1 Functional description

In Rel-8 and Rel-9 the UE disables its E-UTRAN capability as a result of voice domain selection when the UE selects 2G/3G as defined in TS 23.221 [9] and TS 24.301 [10], for example when it passes between TAs that do not support the appropriate voice mechanism i.e. when the UE is IMS VoIP capable and some TAs in E-UTRAN do not support IMS VoIP.

If the UE has disabled its E-UTRAN capability and the SGSN has not informed the UE to re-enable its E-UTRAN capability, then the UTRAN/GERAN does not provide E-UTRAN neighbour cell list to the UE, hence it is impossible for this UE to perform reverse SRVCC handover if it is needed.

Therefore a mechanism is required by the SGSN to signal to the UE to re-enable its E-UTRAN capability when there are adjacent TAs that may provide the appropriate voice mechanism for the UE (in this case IMS VoIP) for the reverse SRVCC mechanism to function.

Three possible mechanisms are envisaged as part of this study:

- Alt. A) broadcast bit in the UTRAN/GERAN network to indicate that there are adjacent E-UTRAN cells that would drive the UE to re-enable its E-UTRAN capability and signal this to the network with a RAU
- Alt. B) indicator in the RAU-Accept message to indicate to the UE to re-enable its E-UTRAN capability if there are adjacent E-UTRAN TAs that support IMS VoIP.
- Alt. C) the UE that supports rSRVCC does not need to disable its E-UTRAN capability even when it passes from TAs that do not support IMS VoIP. The SGSN is statically configured to manipulate the RFSP or the UEs Radio Access Capability (RAC) of the UE based on statically configured information regarding the support of IMS VoIP of the adjacent MME TAs.

A.2 Information flows

A.2.1 Proposed signalling flow for Alternative A to re-enable E-UTRAN capabilities using broadcast indicator

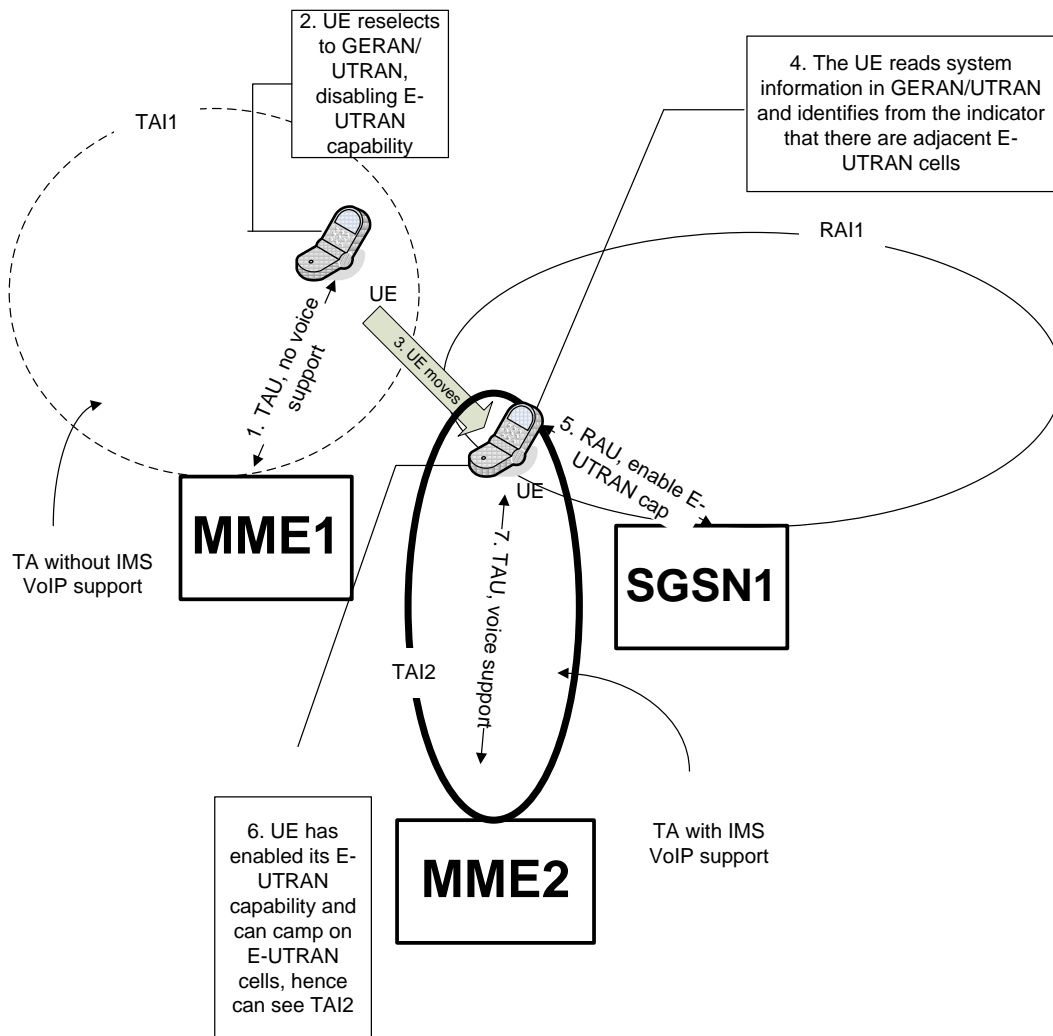

Figure A-1: Alternative A to re-enable E-UTRAN capabilities using Broadcast indicator in GERAN/UTRAN

1. The UE while performing TAU receives "IMS Voice over PS supported Indicator" indicating that voice is not supported in the TA, the UE following procedures described in TS 23.221 [9] and TS 24.301 [10] disables its E-UTRAN capability,
2. The UE reselects to GERAN/UTRAN and disables its E-UTRAN capability.
3. The UE continues to be attached to GERAN/UTRAN reading system information as per the normal procedures while performing mobility in GPRS.
- 4-5. When the UE moves to a cell that indicates that there are adjacent E-UTRAN cells that support IMS VoIP, this triggers the UE to re-enable its E-UTRAN capability. At this stage, even if the UE goes to active mode and initiates a CS voice call in GERAN/UTRAN, given that the UE has signalled its E-UTRAN capability and is able to see adjacent E-UTRAN, the RNC/BSC is able to handover the UE to E-UTRAN using reverse SRVCC procedures.
6. Given that the UE is able to see E-UTRAN cells, following the normal procedures, the UE is able to camp on an E-UTRAN cell and perform TAU to the MME that supports IMS VoIP, hence initiating IMS VoIP calls.

A.2.2 Proposed signalling flow for Alternative B to re-enable E-UTRAN capabilities using NAS indicator

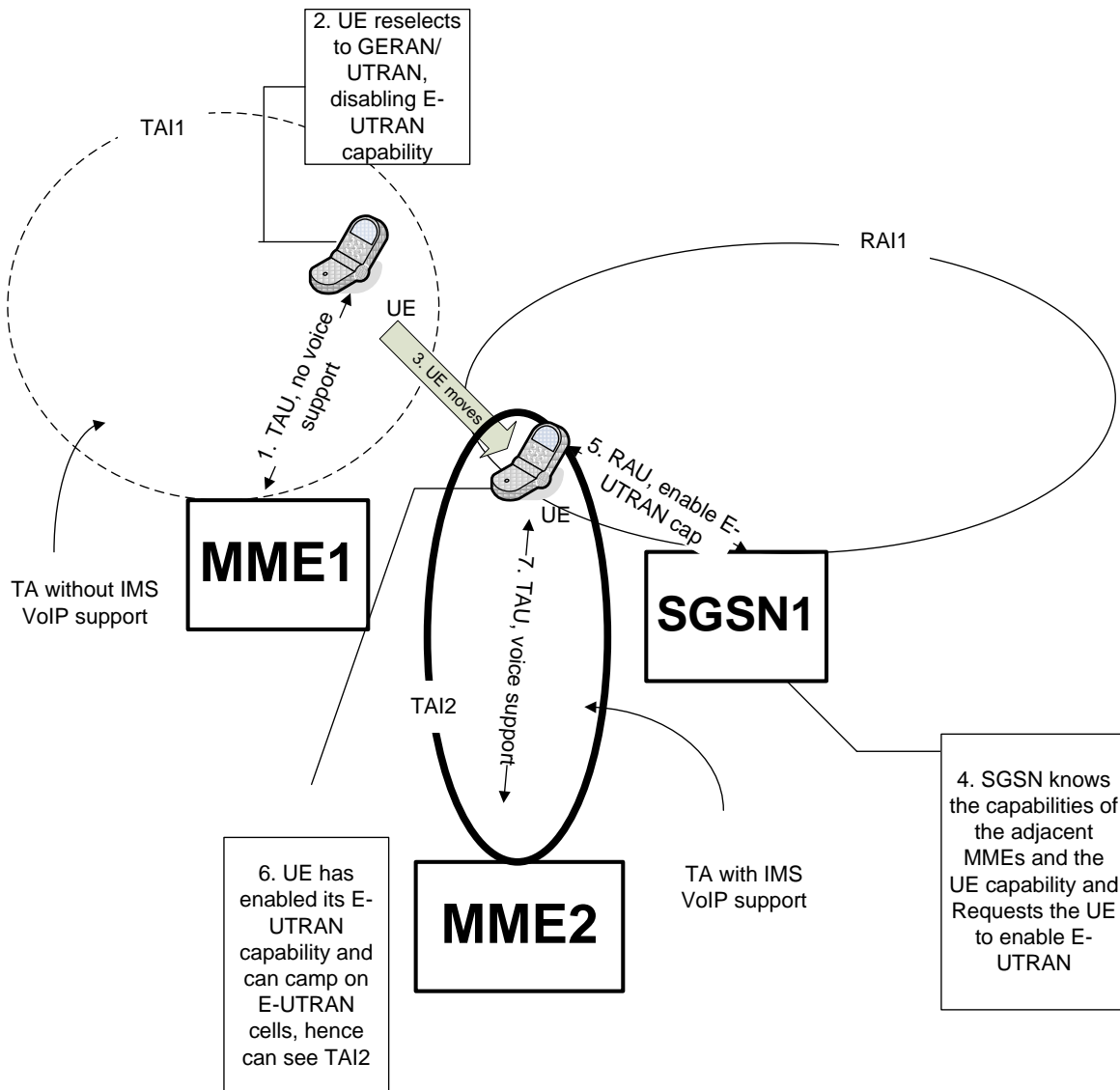

Figure A-2: Alternative B to re-enable E-UTRAN capabilities using NAS indicator

1. The UE while performing TAU receives "IMS Voice over PS supported Indicator" indicating that voice is not supported in the TA, the UE following procedures described in TS 23.221 [9] and TS 24.301 [10] disables its E-UTRAN capability,
2. The UE reselects to GERAN/UTRAN and disables its E-UTRAN capability.
3. The UE continues to be attached to GERAN/UTRAN and performs mobility in GPRS.
- 4-5. When the UE moves to an SGSN that knows that the MME serving TAs adjacent to the RA where the UE is currently attached supports IMS VoIP, it signals to the UE to re-enable its E-UTRAN capability. At this stage, even if the UE goes to active mode and initiates a CS voice call in GERAN/UTRAN, given that the UE has signalled its E-UTRAN capability and is able to see adjacent E-UTRAN, the RNC/BSC is able to handover the UE to E-UTRAN using reverse SRVCC procedures.
6. Given that the UE is able to see E-UTRAN cells, following the normal procedures, the UE is able to camp on an E-UTRAN cell and performs TAU to the MME that supports IMS VoIP, hence initiates IMS VoIP calls.

A.2.3 Proposed signalling flow for Alternative C to re-enable E-UTRAN capabilities using change in RFSP/RAC of the UE

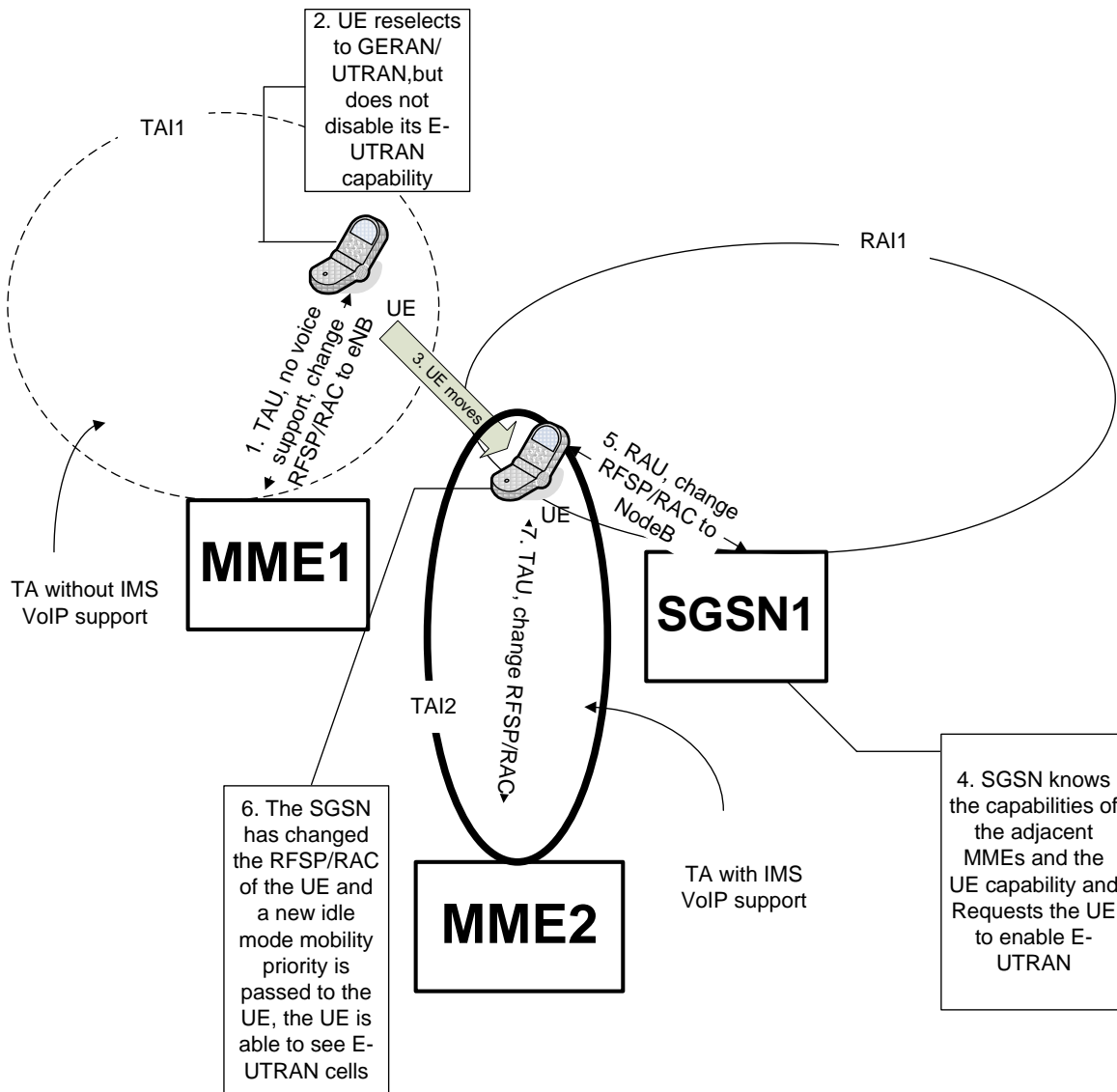

Figure A-3: Alternative B to re-enable E-UTRAN capabilities using changes in RFSP/RAC of the UE

1. The UE while performing TAU receives "IMS Voice over PS supported Indicator" indicating that voice is not supported in the TA, the UE given is rSRVCC capable does not follow procedures described in TS 23.221 [9] and TS 24.301 [10] does not disable its E-UTRAN capability. Rather the MME changes the RFSP or manipulates the RAC of the UE making the eNodeB to change the idle mode priority list, prioritising GERAN/UTRAN instead of E-UTRAN.
2. The UE reselects to GERAN/UTRAN.
3. The UE continues to be attached to GERAN/UTRAN and performs mobility in GPRS.
- 4-5. When the UE moves to an SGSN that knows that the MME serving TAs adjacent to the RA where the UE is currently attached supports IMS VoIP it signals to the NodeB/BSC a new RFSP or changes the RAC of the UE in order to change the idle mode priority list of the UE. At this stage even if the UE goes to active mode and initiates a CS voice call in GERAN/UTRAN is able to see adjacent E-UTRAN, the RNC/BSC is able to handover the UE to E-UTRAN using reverse SRVCC procedures.
6. Given that the UE is able to see E-UTRAN cells, following the normal procedures the UE is able to camp on E-UTRAN cell and performs TAU to the MME that supports IMS VoIP, hence initiates IMS VoIP calls.

Annex B: Mechanisms for GERAN/UTRAN sending Handover/Relocation Required message

When GERAN/UTRAN decides to initiate handover procedure for the rSRVCC capable UE with CS session(s) to a VoIP-capable cell, it shall use a target ID in the Handover/Relocation Required message for CS handover that the message will be forwarded to a MSC Server enhanced for rSRVCC by intermediate node of the source access network. The target ID for CS handover and PS handover shall contain, but does not need to be the same:

- LAI or RAI. The LAI/RAI shall identify the target MME/SGSN (HSPA) and the LAI/RAI in routing table of CS core network points to a MSC Server enhanced for rSRVCC;

NOTE 1: The LAI/RAI can be treated as the rSRVCC indication.

- Index of eNB ID or RNC ID. The index of eNB ID or RNC ID in the target ID maybe related to the target MME/SGSN (HSPA);
- Index of selected TAI if target access is E-UTRAN. The index of selected TAI maybe related to the target eNB.

NOTE 2: Considering only the border cell need to be configured as this way, the table of mapping the target ID to a real target ID understandable in target access network will not be a big table.

The GERAN/UTRAN shall use a target ID in the Relocation Required message for PS handover that messages for both CS handover and PS handover will be forwarded to the same MSC Server enhanced for rSRVCC by intermediate node of the source access network. The target ID for CS handover shall also contain index of source SGSN that related to the source MSC if PS-PS HO is not performed.

An example format of the target ID according to TS 25.413 [12] is LAI + RAC (8 bits) + Extended RNC-ID (16 bits), and the most significant 4 bits of the Extended RNC-ID is the index of source SGSN, the rest 20 bits contains index of eNB ID, and index of selected TAI.

Annex C: Change history

Change history							
Date	TSG #	TSG Doc.	CR	Rev	Subject/Comment	Old	New
2011-08	SP-53	SP-110477	-	-	MCC Editorial update to version 2.0.0 for presentation to TSG SA for Approval	1.4.0	2.0.0
2011-09	SP-53	-	-	-	MCC update to version 11.0.0 after TSG SA#53 approval	2.0.0	11.0.0