

3GPP TR 23.857 V11.0.0 (2012-12)

Technical Report

3rd Generation Partnership Project; Technical Specification Group Core Network and Terminals; Study of Evolved Packet Core (EPC) nodes restoration (Release 11)



The present document has been developed within the 3rd Generation Partnership Project (3GPP™) and may be further elaborated for the purposes of 3GPP. The present document has not been subject to any approval process by the 3GPP Organizational Partners and shall not be implemented. This Specification is provided for future development work within 3GPP only. The Organizational Partners accept no liability for any use of this Specification. Specifications and reports for implementation of the 3GPP™ system should be obtained via the 3GPP Organizational Partners' Publications Offices.

Keywords

LTE, EPC, Restart, Restoration

3GPP

Postal address

3GPP support office address

650 Route des Lucioles - Sophia Antipolis
Valbonne - FRANCE
Tel.: +33 4 92 94 42 00 Fax: +33 4 93 65 47 16

Internet

<http://www.3gpp.org>

Copyright Notification

No part may be reproduced except as authorized by written permission.
The copyright and the foregoing restriction extend to reproduction in all media.

© 2012, 3GPP Organizational Partners (ARIB, ATIS, CCSA, ETSI, TTA, TTC).
All rights reserved.

UMTS™ is a Trade Mark of ETSI registered for the benefit of its members
3GPP™ is a Trade Mark of ETSI registered for the benefit of its Members and of the 3GPP Organizational Partners
LTE™ is a Trade Mark of ETSI currently being registered for the benefit of its Members and of the 3GPP Organizational Partners
GSM® and the GSM logo are registered and owned by the GSM Association

Contents

Foreword	7
1 Scope	8
2 References.....	8
3 Definitions, symbols and abbreviations	9
3.1 Definitions	9
3.2 Abbreviations.....	9
4 Requirements analysis and assumptions	9
5 Failure scenarios	9
5.1 Introduction	9
5.2 MME failure	10
5.2.1 Introduction.....	10
5.2.2 MME failure with Restart.....	10
5.2.3 MME failure without Restart.....	10
5.2.3.1 Outage of CS services	10
5.2.4 MME Partial failure	11
5.3 SGSN failure	11
5.3.1 Introduction.....	11
5.3.2 SGSN failure with Restart.....	11
5.3.3 SGSN failure without Restart.....	11
5.4 SGW failure	12
5.4.1 Introduction.....	12
5.4.2 SGW failure with Restart.....	12
5.4.3 SGW failure without Restart.....	12
5.4.4 SGW Partial failure.....	12
5.5 PGW failure	12
5.5.1 Introduction.....	12
5.5.2 PGW failure with Restart.....	12
5.5.3 PGW failure without Restart.....	13
5.5.4 PGW Partial failure.....	13
6 Alternative solutions	13
6.1 Alternative Solutions for MME failure.....	13
6.1.1 Solution 1 Down Link Data Triggered Attach (DLDTA)	13
6.1.1.1 Description	13
6.1.1.1.1 Down Link Data Triggered Attach (DLDTA) procedure	13
6.1.1.2 Evaluation	15
6.1.1.2.1 Pros.....	15
6.1.1.2.2 Cons.....	16
6.1.2 Solution 2 for MME failure by reattachment with HSS interaction	16
6.1.2.1 Description.....	16
6.1.2.2 Evaluation	17
6.1.2.2.1 Pros.....	17
6.1.2.2.2 Cons.....	17
6.1.3 Solution 3 Pro-active Paging based approach for MME Failure	17
6.1.3.1 Description	17
6.1.3.1.1 General.....	18
6.1.3.1.2 Preparation phase.....	18
6.1.3.1.3 Execution phase	19
6.1.3.2 Evaluation	20
6.1.3.2.1 Pros.....	20
6.1.3.2.2 Cons.....	20
6.1.4 Solution 4 for MME Failure by using the MME self-stored paging information	21
6.1.4.1 Description.....	21
6.1.4.2 Evaluation	21

6.1.4.2.1	Pros.....	21
6.1.4.2.2	Cons.....	22
6.2	Alternative Solutions for SGSN failure	22
6.2.1	Solution 1 Down Link Data Triggered Attach (DLDTA)	22
6.2.1.1	Description	22
6.2.1.1.1	Down Link Data Triggered Attach (DLDTA) procedure	22
6.2.1.2	Evaluation	23
6.2.2	Solution 2 for SGSN failure by reattachment with HSS interaction	23
6.2.2.1	Description	23
6.2.2.2	Evaluation	23
6.2.3	Solution 3 Pro-active Paging based approach for S4-SGSN Failure	23
6.2.3.1	Description	23
6.2.3.2	Evaluation	23
6.2.4	Solution 4 for SGSN failure by using the SGSN self-stored paging information.....	23
6.2.4.1	Description	23
6.2.4.2	Evaluation	24
6.3	Alternative Solutions for SGW failure	24
6.3.1	Solution 1 for SGW failure by MME/S4-SGSN re-establishing resources with a new SGW or to the old SGW after its recovery	24
6.3.1.1	Description	24
6.3.1.2	Evaluation	26
6.3.1.2.1	Pros.....	26
6.3.1.2.2	Cons	26
6.3.2	Solution 2 for SGW failure by PGW initiated paging request at receiving downlink data/signalling	26
6.3.2.1	Description	26
6.3.2.2	Evaluation	28
6.3.2.2.1	Pros.....	28
6.3.2.2.2	Cons	28
6.4	Alternative Solutions for PGW failure	29
6.4.1	Solution 1 for PGW failure with restart	29
6.4.1.1	Description	29
6.4.1.2	Evaluation	29
6.4.1.2.1	Pros.....	29
6.4.1.2.2	Cons	29
6.4.2	Solution 2 for PGW failure without restart.....	29
6.4.2.1	Description	29
6.4.2.2	Evaluation	29
6.4.2.2.1	Pros.....	29
6.4.2.2.2	Cons	29
6.5	EPC restoration procedure if the ISR is activated.....	30
6.5.1	Introduction.....	30
6.5.2	Alternative Solutions for MME/SGSN failure.....	30
6.5.2.1	Solution 1 for MME/SGSN Failure Without Restoration: Providing Complete Service in non-failed node service area.....	30
6.5.2.1.1	Description	30
6.5.2.1.2	Evaluation	31
6.5.2.1.2.1	Pros	31
6.5.2.1.2.2	Cons	31
6.5.2.2	Solution 2 for MME/SGSN Failure Without Restoration: IMSI paging in all accesses	31
6.5.2.2.1	Description	31
6.5.2.2.2	Evaluation	32
6.5.2.2.2.1	Pros	32
6.5.2.2.2.2	Cons	32
6.5.2.3	Solution 3 for MME/SGSN Restart: TMSI paging in both accesses.....	32
6.5.2.3.1	Description	32
6.5.2.3.2	Evaluation	33
6.5.2.3.2.1	Pros	33
6.5.2.3.2.2	Cons	33
6.5.3	Alternative Solutions for SGW failure	34
6.5.3.1	Solution 1 for SGW failure: Deactivated ISR state	34
6.5.3.1.1	Description	34
6.5.3.1.2	Evaluation	34

6.5.3.1.2.1	Pros	34
6.5.3.1.2.2	Cons	34
6.5.3.2	Solution 2 for SGW failure: Maintain the ISR state	35
6.5.3.2.1	Description	35
6.5.3.2.2	Evaluation	36
6.5.3.2.2.1	Pros	36
6.5.3.2.2.2	Cons	36
6.5.3.3	Solution 3 for SGW failure with ISR	37
6.5.3.3.1	Description	37
6.5.3.3.1.1	Mobile Terminating service handling	37
6.5.3.3.1.2	Mobile Originating Service handling	37
6.5.3.3.2	Evaluation	38
6.5.3.3.2.1	Pros	38
6.5.3.3.2.2	Cons	38
6.5.3.4	Solution 4: Preconfigured Node to restore SGW	38
6.5.3.4.1	Description	38
6.5.3.4.2	Evaluation	39
6.5.3.4.2.1	Pros	39
6.5.3.4.2.2	Cons	39
6.6	Restoration of CS services after MME failure	39
6.6.1	Introduction	39
6.6.2	Alternative Solutions for Restoration of CS services after MME failure	40
6.6.2.1	Solution 1 – MT CS services delivery via an alternative MME in MME pool	40
6.6.2.1.1	Description	40
6.6.2.1.2	Evaluation	42
6.6.2.1.2.1	Pros	42
6.6.2.1.2.2	Cons	42
6.7	Detection of EPC Node failure without Restart	43
6.7.1	Introduction	43
6.7.2	Solution 1 – Using Path Management messages	43
6.7.2.1	Description	43
6.8	EPC Node Restoration for Partial Failure of EPC nodes	44
6.8.0	Solutions for general enhancement to the Partial Failure when ISR is active	44
6.8.0.1	Solution 1 : Keep MME FQ-CSID in the PGW when UE is ISR activated	44
6.8.0.1.1	Description	44
6.8.0.1.2	Evaluation	45
6.8.0.1.2.1	Pros	45
6.8.0.1.2.2	Cons	45
6.8.1	Alternative Solutions for MME Partial Failure	45
6.8.1.1	Solution 1: S4-SGSN Clean up when SGW or MME does not support Network Triggered Restoration for MME partial failure	45
6.8.1.1.1	Description	45
6.8.1.1.1.1	Clean-up initiated by SGW procedure	46
6.8.1.1.2	Evaluation	46
6.8.1.1.2.1	Pros	46
6.8.1.1.2.2	Cons	46
6.8.1.2	Solution 2 – Based on Network Triggered Service Restoration for complete MME failure w/o sending Delete PDN Connection Set Request to PGW	46
6.8.1.2.1	Description	46
6.8.1.2.2	Evaluation	46
6.8.1.2.2.1	Pros	46
6.8.1.2.2.2	Cons	47
6.8.1.3	Solution 3 – Based on Network Triggered Service Restoration for complete MME failure with delayed sending of Delete PDN Connection Set Request to PGW	47
6.8.1.3.1	Description	47
6.8.1.3.2	Evaluation	47
6.8.1.3.2.1	Pros	47
6.8.1.3.2.2	Cons	48
6.8.2	Alternative Solutions for SGW Partial failure	48
6.8.2.1	Solution 1 : SGW relocation at the SGW Partial Failure	48
6.8.2.1.1	Description	48
6.8.2.1.2	Evaluation	48

6.8.2.1.2.1	Pros	48
6.8.2.1.2.2	Cons	48
6.8.2.2	Solution 2 : SGW relocation at the SGW Partial Failure when ISR is active	49
6.8.2.2.1	Description.....	49
6.8.2.2.2	Evaluation	49
6.8.2.2.2.1	Pros	49
6.8.2.2.2.2	Cons	49
6.8.3	Alternative Solutions for PGW failure	50
6.8.3.1	Solution 1 for PGW partial failure.....	50
6.8.3.1.1	Description	50
6.8.3.1.2	Evaluation	50
6.8.3.1.2.1	Pros	50
6.8.3.1.2.2	Cons	50
6.9	EPC Node Restoration for Partial Failure of EPC nodes when ISR is active	50
6.9.0	General.....	50
6.9.1	Alternative Solutions for MME Partial Failure	50
6.9.1.1	Solution1 : IMSI paging in E-UTRAN access and TMSI paging in other access	50
6.9.1.1.1	Description.....	50
6.9.0.1.2	Evaluation	51
6.9.0.1.2.1	Pros	51
6.9.0.1.2.2	Cons	52
7	Conclusions and recommendations	53
7.1	MME restoration.....	53
7.1.1	Comparison of proposed solutions	53
7.1.2	Conclusion.....	57
7.2	SGSN Restoration	58
7.2.1	Conclusion.....	58
7.3	SGW restoration	59
7.3.1	Comparison of proposed solutions for SGW failure.....	59
7.3.2	Conclusion.....	60
7.4	PGW restoration	60
7.5	EPC restoration when ISR is active	60
7.5.1	MME/SGSN restoration when ISR is active	60
7.5.1.1	Conclusion	60
7.5.2	SGW Restoration procedure if ISR is activated.....	61
7.5.2.1	Comparison of proposed solutions for SGW failure if ISR is activated	61
7.5.2.2	Conclusion	62
7.6	Restoration of CS services after MME failure	62
7.6.1	Conclusion.....	62
Annex A (informative):	Impacts to Specifications	63
Annex B:	Change history.....	66

Foreword

This Technical Report has been produced by the 3rd Generation Partnership Project (3GPP).

The contents of the present document are subject to continuing work within the TSG and may change following formal TSG approval. Should the TSG modify the contents of the present document, it will be re-released by the TSG with an identifying change of release date and an increase in version number as follows:

Version x.y.z

where:

- x the first digit:
 - 1 presented to TSG for information;
 - 2 presented to TSG for approval;
 - 3 or greater indicates TSG approved document under change control.
- y the second digit is incremented for all changes of substance, i.e. technical enhancements, corrections, updates, etc.
- z the third digit is incremented when editorial only changes have been incorporated in the document.

1 Scope

The present document contains the study on EPC nodes failure and restoration.

This document will consider any necessary operational protocol recovery mechanisms in the EPS in order to restore the subscriber service in the event of EPC node failure or clean up the hanging resource in other EPC nodes if the recovery of the failed node is not possible. The document will address the following aspects:

- list the different network failure scenarios to be analyzed for EPC nodes: MME, S4-SGSN, SGW and PGW;
- identify precisely the problems resulting from the current definition of the standards;
- list various possible solutions;
- identify pros and cons of possible solutions;
- conclude on potential enhancements to the standards (depending on gains vs complexity).

2 References

The following documents contain provisions which, through reference in this text, constitute provisions of the present document.

- References are either specific (identified by date of publication, edition number, version number, etc.) or non-specific.
- For a specific reference, subsequent revisions do not apply.
- For a non-specific reference, the latest version applies. In the case of a reference to a 3GPP document (including a GSM document), a non-specific reference implicitly refers to the latest version of that document *in the same Release as the present document*.

- [1] 3GPP TR 21.905: "Vocabulary for 3GPP Specifications".
- [2] 3GPP TS 23.007: "Restoration procedures".
- [3] 3GPP TS 29.274: "Evolved General Packet Radio Service (GPRS) Tunnelling Protocol for Control plane (GTPv2-C); Stage 3".
- [4] 3GPP TS 24.301: "Non-Access-Stratum (NAS) protocol for Evolved Packet System (EPS)".
- [5] 3GPP TS 24.008: "Mobile Radio Interface Layer 3 specification; Core Network Protocols; Stage 3".
- [6] 3GPP TS 23.401: "General Packet Radio Service (GPRS) enhancements for Evolved Universal Terrestrial Radio Access Network (E-UTRAN) access".
- [7] 3GPP TS 23.060: "General Packet Radio Service (GPRS); Service description".
- [8] 3GPP TS 23.272: "Circuit Switched (CS) fallback in Evolved Packet System (EPS); Stage 2".
- [9] 3GPP TS 29.118: "Mobility Management Entity (MME) – Visitor Location Register (VLR) S-GW interface specification".
- [10] 3GPP TS 23.018: "Basic call handling; Technical realization".

[11] 3GPP TS 23.236: "Intra Domain Connection of RAN Nodes to Multiple CN Nodes".

3 Definitions, symbols and abbreviations

3.1 Definitions

For the purposes of the present document, the terms and definitions given in TR 21.905 [1] and the following apply. A term defined in the present document takes precedence over the definition of the same term, if any, in TR 21.905 [1].

3.2 Abbreviations

For the purposes of the present document, the abbreviations given in TR 21.905 [1] and the following apply. An abbreviation defined in the present document takes precedence over the definition of the same abbreviation, if any, in TR 21.905 [1].

EPC	Evolved Packet Core
EPS	Evolved Packet System
GTP	GPRS Tunnelling Protocol
MME	Mobility Management Entity
PGW	PDN Gateway
SGW	Serving Gateway

4 Requirements analysis and assumptions

The following are the requirements considered as the criteria for developing solutions provided in this study.

- The impact or degradation of the service affect on the user shall be minimised.
- The solution shall not cause overload or congestion in the Core Network and RAN.
- The solution shall support pre-Rel10 UEs but not necessary with the same level of efficiency and performance to that provided for UEs from Rel-10 onwards.
- The solution should minimise the resource reservation in the Core Network and RAN.
- The impact for the hPLMN by EPC node failure of vPLMN shall be minimised.
- The deployment of LTE/EPC and SGs interface shall not impair the delivery of Mobile Terminated CS services (e.g. CS call, SMS).

5 Failure scenarios

5.1 Introduction

The following figure shows the network elements of the EPC. According to this the targets for the study are coloured red in the following figure.

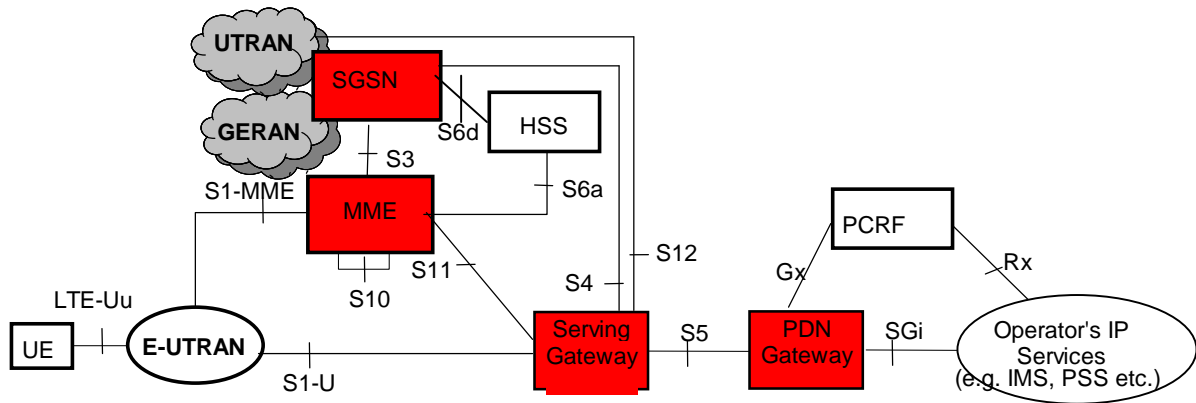

Figure 5.1-1: Network elements to be considered in the study

The following clauses cover each of the possible failure cases and indicate how they affect service.

5.2 MME failure

5.2.1 Introduction

This section will analyse the scenarios for MME failure and corresponding consequences according to the current procedures.

MME failure will be detected by the SGW as per restart procedure specified in 3GPP TS 23.007 [2]. MME failure will take place in the following scenarios:

- MME failure with Restart;
- MME failure without Restart.

5.2.2 MME failure with Restart

According to the current mechanism described in 3GPP TS 23.007 [2], when an SGW detects that a peer MME has restarted, it shall delete all PDN connection table data/MM bearer contexts associated with the peer node that fails as well as freeing any internal SGW resources associated with those PDN connections. Since there are no bearer/MM contexts in the SGW, the mobile terminated service cannot be delivered to the UE for long time. The UE will reattach to the network only when the UE has uplink signalling or data to send.

5.2.3 MME failure without Restart

Editor's Note: to be completed

5.2.3.1 Outage of CS services

With the deployment of LTE in mobile networks, there is the risk that mobile terminated CS services (e.g. CS calls, SMS, Mobile termination Location request) cannot be successfully delivered to the subscriber for a long period (up to the periodic Tracking Area Update timer e.g. 1 hour) after an MME failure without restart or a long MME failure.

A UE under LTE that requires support of CS or/and SMS services performs a combined attach procedure to attach for both EPS and non-EPS services (i.e. CS services), or both EPS services and "SMS only" services, and a combined tracking area update procedure to update the registration of the actual tracking area (see 3GPP TS 23.401 [6] and 3GPP TS 24.301 [4]). During those procedures, the serving MME initiates a location update for non-EPS services procedure towards the VLR providing the CS or/and SMS services, thereby establishing an SGs association between the MME and VLR (see 3GPP TS 23.272 [8] and 3GPP TS 29.118 [9]). Upon receipt of a subsequent CS terminated service (e.g. MT CS call or SMS), the VLR sends an SGs Paging Request message to the serving MME with a "CS call indicator" or an "SMS indicator" which triggers a CS Fallback procedure or SMS transfer via LTE (see 3GPP TS 23.272 [8] and 3GPP TS 29.118 [9]).

Restoration procedures are defined in 3GPP TS 29.118 [9] (see in particular clause 5.1.3) to maintain mobile terminated CS services (e.g. CS call or SMS) when an MME fails but restarts. They essentially rely on the principle that MME accepts SGs-paging request received for unknown UEs for a certain period after the MME restart whose duration typically covers the largest tracking area update timer assigned to UEs. During that period, the MME sets a system-wide parameter MME-reset to true. After that period, the MME sets the MME-reset parameter to false and stops accepting SGs paging request for unknown UEs.

But if the MME fails without restart, or if the MME fails for a long duration, it is no longer possible for the VLR to page the UE via the MME. Since UEs in idle mode are not aware of the MME failure until they need to send some uplink data or signalling (e.g. periodic Tracking Area Update), they remain under LTE but cannot receive any more mobile terminated services.

5.2.4 MME Partial failure

According to the current mechanism described in 3GPP TS 23.007 [2], when an SGW receives a GTPv2 Delete PDN Connection Set Request message from a MME as the result of a partial failure in the MME, it shall retrieve all the PDN connections corresponding to each of the FQ-CSID(s) present in the message and shall delete all the retrieved PDN connections and the associated resources. Since there are no bearer/MM contexts in the SGW, the mobile terminated service cannot be delivered to the affected UEs for long time, i.e. up to Periodic TAU timer expiry. The UE will reattach to the network only when the UE has uplink signalling or data to send.

According to current mechanisms in 23.007 [2], when a SGW receives a Delete Connection Set request from MME, it shall forward the Delete PDN Connection Set request to PDN GW. The PDN GW also deletes the PDN Connections locally corresponding to the CS-ID received in the Delete PDN connection Set Request.

For ISR activated UEs, the SGSN and MME both share the UE context. Since the SGSN is not aware of the partial failure in the MME, SGSN is also unaware that the PDN connections have been lost. Therefore the UE in SGSN service area may face service interruption for a period of time till it uplink NAS signalling triggers interaction with Serving GW for the UE.

5.3 SGSN failure

5.3.1 Introduction

This section will analyse the scenarios for SGSN failure and corresponding consequences according to the current procedures.

SGSN failure will be detected by the SGW as per restart procedure specified in 3GPP TS 23.007 [2]. SGSN failure will take place in the following scenarios:

- SGSN failure with Restart;
- SGSN failure without Restart.

5.3.2 SGSN failure with Restart

According to the current mechanism described in 3GPP TS 23.007 [2], when an SGW detects that a peer SGSN has restarted, it shall delete all PDN connection table data/MM bearer contexts associated with the peer node that fails as well as freeing any internal SGW resources associated with those PDN connections. Since there are no bearer/MM contexts in the SGW, the mobile terminated service cannot be delivered to the UE for long time. The UE will reattach to the network only when the UE has uplink signalling or data to send.

5.3.3 SGSN failure without Restart

Editor's Note: to be completed

5.4 SGW failure

5.4.1 Introduction

This section will analyse the scenarios for SGW failure and corresponding consequences according to the current procedures.

SGW failure will be detected by the PGW, MME and SGSN as per restart procedure specified in 3GPP TS 23.007 [2]. SGW failure will take place in the following scenarios:

- SGW failure with Restart;
- SGW failure without Restart.

5.4.2 SGW failure with Restart

According to the current mechanism described in 3GPP TS 23.007 [2], when a PGW/MME/SGSN detects that a peer SGW has restarted, it shall delete all PDN connection table data/MM bearer contexts associated with the peer node that fails as well as freeing any internal PGW/MME/SGSN resources associated with those PDN connections. Since there are no bearer/MM contexts in the PGW, the mobile terminated service cannot be delivered to the UE for long time. If the MME/SGSN performs implementation specific action to cleanup external resources, including at eNodeB/RNC and UE, the UE will be reattached to the network and the EPS services will be restored. Otherwise the UE will be reattached to the network only when the UE has uplink signalling or data to send.

5.4.3 SGW failure without Restart

Editor's Note: to be completed

5.4.4 SGW Partial failure

According to the current mechanism described in 3GPP TS 23.007 [2], when an MME/PGW receives a GTPv2 Delete PDN Connection Set Request message from a SGW as the result of a partial failure in the SGW, MME/PGW shall retrieve all the PDN connections corresponding to each of the FQ-CSID(s) present in the message and shall delete all the retrieved PDN connections and the associated resources. Since there are no bearer/MM contexts in the PGW, the mobile terminated service cannot be delivered to the UE for long time. If the MME performs implementation specific action to cleanup external resources, including at eNodeB and UE, the UE will be reattached to the network and the EPS services will be restored. Otherwise the UE will be reattached to the network only when the UE has uplink signalling or data to send.

5.5 PGW failure

5.5.1 Introduction

This section will analyse the scenarios for PGW failure and corresponding consequences according to the current procedures.

PGW failure will be detected by the SGW as per restart procedure specified in 3GPP TS 23.007 [2]. PGW failure will take place in the following scenarios:

- PGW failure with Restart;
- PGW failure without Restart.

5.5.2 PGW failure with Restart

According to the current mechanism described in 3GPP TS 23.007 [2], when a SGW detects that a peer PGW has restarted, it shall delete all PDN connection table data/MM bearer contexts associated with the peer node that fails as well as freeing any internal SGW resources associated with those PDN connections. Since there are no bearer/MM

contexts in the PGW, the mobile terminated service cannot be delivered to the UE for long time. In Rel-10, if the SGW detects the PGW has restarted, the SGW may send a PGW Restart Notification message to the MME/S4-SGSN. When the MME/S4-SGSN receives the PGW Restart Notification message, it should delete all PDN connection table data associated with the restarted PGW. If the MME/S4-SGSN performs implementation specific action to cleanup external resources, including at eNodeB/RNC and UE, the UE may reattach to the network again.

5.5.3 PGW failure without Restart

According to the current mechanism described in 3GPP TS 23.007 [2], mobile terminated services cannot be delivered to the UE for a long time if a PGW fails without restart. The PGW cannot send downlink data to the SGW. Additionally when detecting a path failure with the peer PGW, the SGW deletes the affected PDN connections immediately or a bit later if the path is still down after an operator configurable maximum path failure duration.

The SGW cannot signal the PGW failure to the MME/S4-SGSN either, which prevents the MME/S4-SGSN to restore PDN connections (via alternative PGWs).

5.5.4 PGW Partial failure

According to the current mechanism described in 3GPP TS 23.007 [2], when an SGW receives a GTPv2 Delete PDN Connection Set Request (or PMIP6 Binding Revocation Indication with Gbit set) message from a PGW as the result of a partial failure in the PGW, the SGW shall retrieve all the PDN connections corresponding to each of the FQ-CSID(s) present in the message and shall delete all the retrieved PDN connections and the associated resources. The SGW shall also send a S11 GTPv2 Delete PDN Connection Set Request message containing the FQ-CSID(s) provided by the PGW to MME peers supporting the feature. Since there are no bearer/MM contexts in the PGW, the mobile terminated service cannot be delivered to the UE for long time. If the MME performs implementation specific action to cleanup external resources, including at eNodeB and UE, the UE may be requested to re-establish the PDN connection. Otherwise the UE will re-establish the PDN connection only when the UE has uplink signalling or data to send.

6 Alternative solutions

6.1 Alternative Solutions for MME failure

6.1.1 Solution 1 Down Link Data Triggered Attach (DLDTA)

6.1.1.1 Description

The Down Link Data Triggered Attach (DLDTA) is an optional feature for MME, S4-SGSN and SGW.

6.1.1.1.1 Down Link Data Triggered Attach (DLDTA) procedure

The DLDTA enables UEs to make the re-attach to the EPS possible triggered by an arrival of the downlink packet after the MME has restarted. The DLDTA is composed of the following components.

- a) The MME marks an EPS bearer as the subject for the DLDTA :

When EPS bearer is established, based on the operator policy the MME marks an EPS bearer as the subject for the DLDTA by setting the DLDTA flag in the EPS bearer Context. The MME may activate the DLDTA for all EPS bearers or based on QCI, Priority Level or/and APN.

NOTE1: MME may activate the DLDTA for minimal number of EPS bearers. For example, in order to make the IMS terminating call to be a trigger for the UE re-attachment, the DLDTA is only activated for those of EPS bearers which has the QCI=5 (IMS Signalling).

- b) The SGW maintains the IMSI, latest TA-list per UE:

If the UE has at least one EPS bearer that has the DLDTA flag active and the latest TA list is changed , for example due to the mobility management procedure, the MME transfers the latest TA list to the corresponding SGW by the Create Session Request message or/and the Modify Bearer Request message.

If the SGW receives the dedicated Modify Bearer Request message from the MME only for the purpose of updating the latest TA list, the SGW shall not forward the Modify Bearer Request message to the PGW. Instead, the SGW sends the Modify Bearer Response message to the MME.

NOTE2: The TA list is essential in case of MME restart since it allows avoiding the IMSI page for the entire coverage of an MME (which is extremely stressful for the EPS system, since a large number of eNBs is typically covered by one MME). To minimize any extra S11 signalling during Intra-MME Intra-SGW relocations, the MME may store in the SGW a list of TAIs (or a Paging Area ID representing such list) which is a superset of the actual list of TAIs returned to the UE during the Attach / TAU procedures. It should be up to each MME implementation to decide which exact TAIs list to store in the SGW.

c) The SGW maintains the S5/S8 bearers after the MME has restarted:

If the SGW detects the MME restart by referring to the increase of the restart counter, instead of removing associated resources, the SGW maintains the S5/S8 bearers if the DLDTA flag is active. This makes it possible for the SGW to receive a down link packet from the PGW.

When SGW starts maintaining the S5/S8 bearers, SGW starts the DLDTA timer for corresponding MME. If the DLDTA timer expires, the maintained resources due to the DLDTA shall be locally deleted. This treatment is required in case the other SGW is chosen when UE re-attaches to the EPC after the MME failure. A value of the DLDTA timer may be equal to the periodic tracking area update timer (timer T3412) as specified in the 3GPP TS 24.301 [4]. There is one DLDTA timer in the SGW.

NOTE 3: From Rel-10 onwards, operators may configure subscriber's specific Periodic TAU/RAU timer in the HLR/HSS. See 3GPP TS 23.401 [6] subclause 4.3.17.3. It is however sufficient to use a single DLDTA timer in the SGW. This timer may be set e.g. to the largest TAU timer allocated to subscribers with DLDTA.

When SGW receives the Create Session Request message from the UE while the DLDTA timer is running, the SGW deletes all DLDTA related resources for the UE and then proceeds with the Create Session Request message handling.

d) Downlink data packet/ Control signal message arrives to the SGW while the DLDTA timer is running:

When SGW receives the downlink data packet/ Control signal message from the PGW using the EPS bearer that has the DLDTA flag active, the SGW sends the enhanced Downlink Data Notification message with the IMSI and TA list to the MME in order to page UE. The TA list on the enhanced Downlink Data Notification message is used by MME for sending the page message over the S1-MME interface if the MME does not have a valid UE context.

The SGW shall reject the control message received from the PGW with an appropriate cause value.

If the MME receives the Downlink Data Notification message with the IMSI to a UE either who has the valid UE context or the MME has received the Cancel Location Request message for that UE after the MME restarted, the MME does not send page message over the S1-MME interface and replies the Downlink Data Notification Acknowledge to the SGW with cause value "Re-Attach Success". In this case, the SGW releases the corresponding internal resources and may perform bearer deactivation procedure toward the P-GW according to 3GPP TS 23.007[2].

NOTE 4: In case the HSS sends the Cancel Location Request message to the MME while MME is being failed (out of service), the Downlink Data Notification message with the IMSI triggers the IMSI page unfortunately.

Upon receiving a page message with IMSI, UE starts the re-attach procedure as specified in subclause 5.6.2.2.2 of the 3GPP TS 24.301 [4].

e) The SGW pages UE again if MME cannot find the UE context when the Data Notification message is received:

When the SGW receives the Downlink Data Notification Acknowledge message with error cause "context not found" from the MME for the EPS bearer that has the DLDTA flag active, then the SGW re-sends the enhanced Down Link Data Notification with IMSI and TA list. This procedure is required in case the downlink packet arrives from the PGW right before the SGW detects the MME restart.

f) The other mobility related procedures:

When the MME is changed due to the mobility management, source MME shall forward the DLDTA flag in the EPS bearer Context to new MME.

When the SGW is changed due to the mobility management, the latest TA list is informed to new SGW .

g) The ISR related procedures :

If the ISR is active, the SGW maintains both the latest TA list and the latest RAI.

The procedure d) in this subclause can be executed per S4/S11 interface independently irrespective of the ISR activation status. The figure 6.1.1-1 outlines the overall DLDTA procedure.

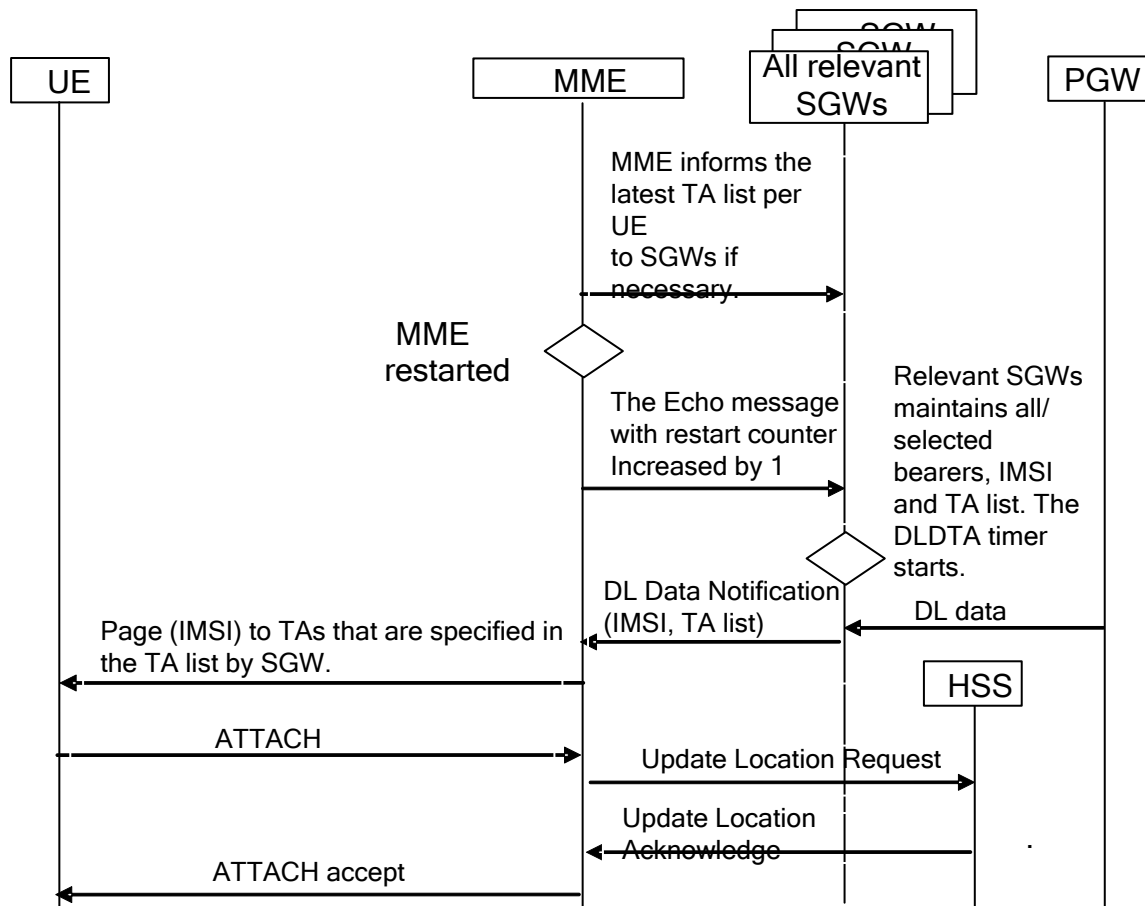

Figure 6.1.1.1-1: The overall DLDTA procedure

6.1.1.2 Evaluation

6.1.1.2.1 Pros

This subclause lists the pros of solution 1 DLDTA as following:

EPS Service after MME Restart: This approach enables UEs to make the re-attach to the EPS possible triggered by an arrival of the downlink packet after the MME has restarted;

No inter PLMN dependency: This approach does not require any support from the EPC node across PLMNs. The approach only requires support in the SGW and MME;

IMSI paging in the latest TAI list: This approach performs the IMSI paging in the latest TAI list which is stored in the SGW. This can avoid paging in all TAI list served by the MME and save some radio resource.

6.1.1.2.2 Cons

This subclause lists the cons of solution 1 DLDTA as following:

Extra signalling over S11 interface: This approach requires the TAI list for each UE to be stored in the SGW in order to avoid sending the paging request for the UE in all the TAI lists supported by the MME. Hence, the change in TAI list needs to be updated by sending extra signalling message over the S11 interface in the intra MME intra SGW TAU procedure. This extra signalling can however be minimized by storing in the SGW a list of TAIs (or a Paging Area ID representing such list) which is a superset of the actual list of TAIs returned to the UE during the Attach / TAU procedures.

Resources maintained in the SGW after the MME restart detection: This approach requires reservation of UE resource (IMSI, S5/S8 bearer contexts and TAI list) until downlink packets arrives for the UE or DLDTA timer expires;

UE movement before old SGW receives the downlink packets on the maintained bearers: If the UE moves to new MME area, it would reattach to the network through the new MME. If the UE has already reattached to another MME and the old SGW receives the downlink packets on the maintained bearers to trigger the IMSI paging. e.g. if the UE establishes a new PDN connection to a different APN which was used by the UE before the MME restarts. This will cause UE to reattach to the network again.

Mobile Terminated Service which triggers the paging will fail: The SGW receives the downlink packets on the maintained bearers which will trigger the paging. However the downlink packets will be dropped by the SGW and cannot be delivered to the UE.

6.1.2 Solution 2 for MME failure by reattachment with HSS interaction

6.1.2.1 Description

This solution enables the UE to reattach to EPS triggered by downlink data packets or signalling after MME restarts. This solution includes the following steps:

- 1) The SGW maintains the IMSI and S5/S8 bearers after detection of MME restart

If the SGW detects the MME restarts by referring to restart counter, instead of removing associated resources, the SGW maintains the S5/S8 bearers. This makes it possible for the SGW to receive downlink data packets or signalling from the PGW. How to maintain the S5/S8 bearers is based on the maintaining policy which is decided by the MME or PCRF during the bearer establishment procedure.

When SGW starts maintaining the S5/S8 bearers, SGW starts a timer for corresponding restarted MME. The timer value may be equal to periodic tracking area update timer (timer T3412) as specified in 3GPP TS 24.301 [4]. If the timer expires, the maintained resources shall be locally deleted.

When SGW receives the Create Session Request message for the UE while the timer is running, the SGW deletes all maintained resources for the UE and then proceeds with the Create Session Request message handling as specified in 3GPP TS 29.274 [3].

- 2) Downlink data packets or signalling arrives to the SGW while the timer in the step1) is still running.

When the SGW receives the downlink data packets on the maintaining bearer or signalling for establishing new bearers, the SGW shall reject the signalling message received from the PGW with an appropriate cause value and sends an enhanced Downlink Data Notification message including IMSI to the associated MME.

- 3) The MME will check whether the UE has been registered to another MME.

After the MME receives enhanced Downlink Data Notification message including IMSI, the MME will check whether the UE has been registered to another MME by sending enhanced Update Location Request including IMSI and restoration indication to the HSS. If the UE has not been registered to another MME, the HSS will send Update Location Response including subscription data. Otherwise the HSS will reject Update Location Request with appropriate cause.

NOTE: This step can avoid double IMSI paging if the UE has already reattached to another MME and the old SGW receives the downlink packets on the maintained bearers, e.g. if the UE establishes a new PDN connection to a different APN which was used by the UE before the MME restarts.

- 4) The MME pages the UE in the MME serving area using the IMSI if the UE has not been registered to another MME.

Upon receiving a page message with IMSI, UE starts the reattach procedure as specified in subclause 5.6.2.2.2 of 3GPP TS 24.301 [4].

6.1.2.2 Evaluation

6.1.2.2.1 Pros

This subclause lists the pros of solution 2 MME failure by reattachment with HSS interaction as following:

EPS Service after MME Restart: This approach enables UEs to make the re-attach to the EPS possible triggered by an arrival of the downlink packet after the MME has restarted;

No extra signalling over S11 interface: This approach requires to send the paging request for the UE in all the TAI lists served by the MME. Hence, there is no extra signalling message over the S11 interface in the intra MME intra SGW TAU procedure;

Double IMSI paging can be avoided if the UE has already reattached to another MME: After the MME receives enhanced Downlink Data Notification message including IMSI, the MME will check whether the UE has been registered to another MME. This can avoid double IMSI paging if the UE has already reattached to another MME and the old SGW receives the downlink packets on the maintained bearers.

6.1.2.2.2 Cons

This subclause lists the cons of solution 2 MME failure by reattachment with HSS interaction as following:

Resources maintained in the SGW after the MME restart detection: This approach requires reservation of UE resource (IMSI, S5/S8 bearer contexts) until downlink packets arrives for the UE or the timer as specified in the step 1) in subclause 6.1.2.1 expires;

Mobile Terminated Service which triggers the paging will fail: The SGW receives the downlink packets on the maintained bearers which will trigger the paging. However the downlink packets will be dropped by the SGW and cannot be delivered to the UE.

IMSI paging in the MME serving area: The MME performs the IMSI paging in all TAI lists served by the MME. Some radio resources for IMSI paging will be consumed.

PLMN dependency for inbound roaming UE: the MME will check whether the UE has been registered to another MME by sending enhanced Update Location Request including IMSI and restoration indication to the HSS. The HSS in the HPLMN will be enhanced for the inbound roaming UE.

6.1.3 Solution 3 Pro-active Paging based approach for MME Failure

6.1.3.1 Description

In the event of failure of the MME, the network may initiate the paging for EPS services using the IMSI as specified in 3GPP TS 24.301 [3]. Network initiating paging using the IMSI as soon as the MME failure is detected is termed as Pro-active paging. The trigger for this type of paging is detection of the failure of the MME.

Following terms are used for the depiction of this solution.

Anchor MME – The MME which has the UE's Bearer/MM context, and hence anchoring the UE before the failure, is termed as Anchor MME.

Paging MME – The MME which is selected by the SGW to perform IMSI based paging procedure is termed as Paging MME. If the SGW is not configured with in an MME pool then the Anchor MME and Paging MME are the same. In the case of MME pools, the SGW can select any MME or set of MMEs from the MME pool as Paging MME(s).

6.1.3.1.1 General

The Pro-active paging approach based on UE Context Reestablishment (UCR) is divided into following two phases:

- Preparation phase: During this phase, the MME is in good health and has a valid UE context. The Anchor MME prepares the SGW to assist the MME to reestablish the UE's context in the event of the Anchor MME's failure. This phase is characterized by the following functions.
 - i. Based on various criteria, the Anchor MME decides to enable/disable the context reestablishment for a particular UE, which is referred as "UE Requiring Context Reestablishment" (URCR) status. The URCR status "enabled" indicates that the UE is subjected to context reestablishment. The UE's URCR status is provided by the Anchor MME to the associated SGW.
 - ii. For the UE with URCR status enabled, the Anchor MME provides the associated SGW with the Data to Assist IMSI Paging (DAIP). The associated SGW stores the URCR status and the latest DAIP for each UE as provided by the Anchor MME.
- Execution phase: This phase is executed only when the SGW detects failure of the Anchor MME. If the SGW is configured with the MME pool, this phase can be triggered as soon as the SGW detects failure of the Anchor MME. However, in the absence of the MME pool, this phase can be triggered only on the detection of the Anchor MME restart. This phase is characterized by the following functions.
 - i. For UEs with URCR status enabled, the SGW provides DAIP to the Paging MME for each UE. In case of the MME pool, the SGW can select a different Paging MME for the different UEs and hence the IMSI based paging procedure can be done in parallel. If the MME has failed with a Restart, the SGW may select the anchor MME as paging the MME; otherwise, if the MME has failed without a Restart, the SGW shall select an MME different from the failed MME in the MME pool as paging the MME.
 - ii. On the reception of the UE's DAIP, the MME initiates "Paging for EPS/GPRS services using IMSI" as specified in 3GPP TS 24.301 [4].
 - iii. On reception of the "Paging using IMSI", the UE initiates "Initial Attach" procedure and hence reattaches to the network. As the UE's context is reestablished in the network, the EPS services can be delivered to the UE.

6.1.3.1.2 Preparation phase

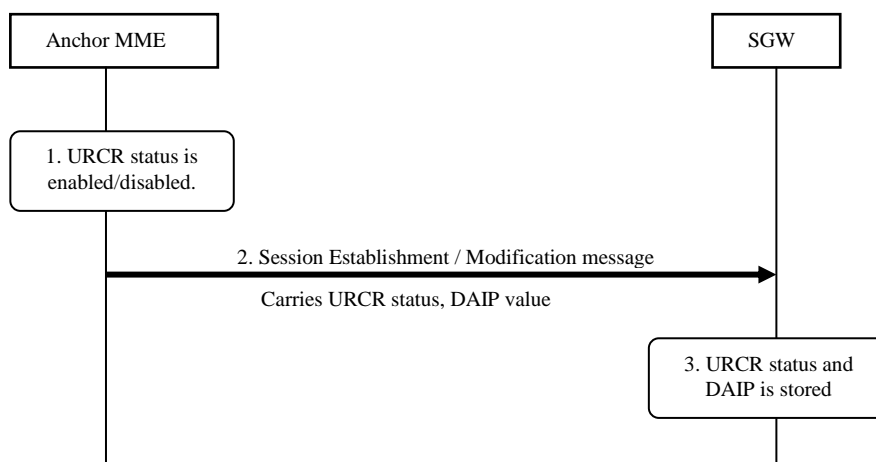

Figure 6.1.3.1.2-1: UE Context Reestablishment procedures, Preparation phase

- 1) During session establishment and session modification procedures, the Anchor MME decides to enable/disable URCR status of the UE based on various criteria as given below.
 - Subscription profile e.g. High priority users;
 - Currently active PDN connection, currently active bearer's QCI/ARP values etc;
 - Operator's local policy;

Based on the above criteria, the Anchor MME can decide to change the current URCCR status to "enabled" or "disabled". Hence the previously "enabled" URCCR status can be "disabled" dynamically by the Anchor MME; the previously "disabled" URCCR status can be "enabled" by the Anchor MME based on the EPS services currently activated by the UE.

MME may activate URCCR status of the UE for minimal number of UEs based on QCI, Priority Level or/and APN of UE's PDN connections. For example, in order to make the IMS terminating call to be a trigger for the UE re-attachment, the URCCR is only enabled for those of UE which has the QCI=5 bearer (IMS Signalling). Or in order to allow the high priority user to re-attach to the network, the URCCR is only activated for the high priority users.

- 2) During the existing/additional S11 interface signalling for the session establishment and/or session modification, the MME sends the URCCR status to the associated SGW. If the URCCR status is "enabled", the Anchor MME may provide the latest DAIP to the SGW. The DAIP is a container to hold UE paging related information, which can be used by the Paging MME to initiate IMSI based paging request message to the UE in the event of Anchor MME failure. From the SGW point of view, the DAIP is just transparent container whose content is specific to the implementation of the Anchor MME and Paging MME.
- 3) The SGW shall store the URCCR status and latest DAIP for the UE, if it receives from Anchor MME. If the latest DAIP is not provided then the SGW assumes old value of DAIP as the latest value of DAIP. The Anchor MME shall provide the DAIP when the URCCR status for a particular UE is enabled for the first time.

6.1.3.1.3 Execution phase

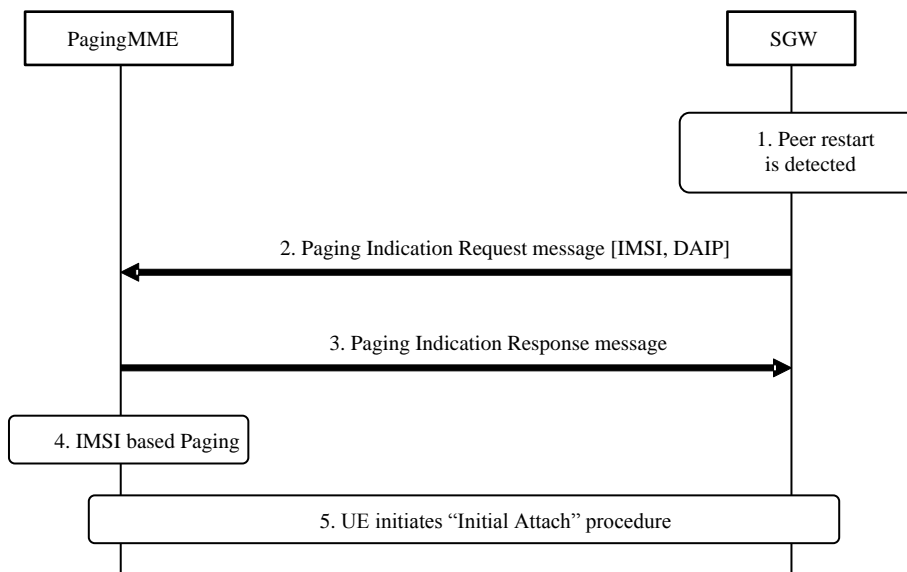

Figure 6.1.3.1.3-1: UE Context Reestablishment procedure, Execution phase

- 1) The SGW detects failure of the associated Anchor MME as specified in 3GPP TS 23.007 [2] section 18 and 3GPP TS 29.274 [3] section 7.8.
- 2) On the detection of the failure of the Anchor MME, the SGW performs restoration procedure as specified in 3GPP TS 23.007 [2] section 16.1.1. Additionally, the SGW checks the URCCR status of the affected UEs. If the URCCR status of the UE is enabled then the SGW sends "Paging Indication Request" message to the Paging MME. The SGW shall provide the latest DAIP to the Paging MME in "Paging Indication Request" message.

In case of the MME pool, the selection of the Paging MME(s) is left to the SGW implementation. The simplest approach can be to select different MMEs as Paging MMEs (from the MME pool) for the different UEs in round robin cycle. The Paging MME(s) in the MME pool automatically acts as a load balancing MMEs and helps in executing the IMSI based paging procedure simultaneously. 3) The Paging MME acknowledges the reception of the Paging Indication message by sending "Paging Indication Response" message to SGW. The SGW shall distinguish the scenarios of the MME failure, if the MME has failed with a restart, the SGW may select the

anchor MME as the paging MME; otherwise, if the MME has failed without a Restart, the SGW shall select an MME different from the failed MME, from the MME pool, as the paging MME.

- 4) The Paging MME initiates IMSI based paging based on the information received in the DAIP for the specified IMSI. Please refer to 3GPP TS 24.301 [4] for IMSI based paging procedure.
- 5) On reception of the paging request message with IMSI as UE identity, the UE shall deactivate any EPS bearer context(s) locally and initiates "Initial Attach" procedure. On the successful completion of the initial attach procedure the UE is reattached to the network and hence able to receive any EPS services.

6.1.3.2 Evaluation

6.1.3.2.1 Pros

EPS Service Delivery after MME Restart/Failure: This approach initiates the re-establishment of the UE's context as soon as the restart/failure of the MME is detected. Once the UE is re-attached to the network, at the most paging procedure may be initiated (if the UE is in idle mode) to delivery EPS services to the UE. Since the paging procedure is less resource intensive and has predictably lower latency value, this approach is guaranteed to deliver EPS services with reasonable low latency.

No inter PLMN dependency: This approach does not require any support from the EPC node across PLMNs. The approach only requires support in the SGW and MME.

No/Minimal Resource Reservation in EPC nodes post MME restart/failure: Post MME failure, this approach requires reservation of the UE related resources (DAIP in SGW) for a comparatively short time, till the related information is provided to the paging MME, and hence has no or negligible impact on capacity of the EPC nodes.

No dependency on any session/mobility related parameter: The pro-active paging has no dependency upon the session/mobility parameters (such as TAU timer value). Hence, pro-active paging approach is well suited for present and future types of EPS services.

6.1.3.2.2 Cons

Extra signalling over S11 interface: The approach requires latest value of the TAI list to be updated in the SGW in order to avoid sending the paging request for the UE in all the TAI lists supported by the MME. Hence, the change in TAI list needs to be updated by sending extra Modify Bearer Request message over S11 interface, in case there session management signalling.

UE movement before the paging MME sends paging request message: If the UE moves to new MME area, it would reattach to the network through the new MME and enter the connected mode. If the UE inactivity timer is short, the UE may enter the idle mode in the new MME. If the paging MME has not initiated the paging request, before the UE enters idle mode under new MME, the paging request would cause UE to reattach to the network again.

Possible overload of Radio and Core Network Nodes: This approach initiates paging towards all the UE for which the URRCR status is enabled, as soon as the MME restart/failure is detected. Depending upon various parameters, such as: number of UEs for which URRCR status is enabled, number of eNBs handled by the failed/restarted MME, the attach procedure processing rate of the MME, number of MMEs in the MME pool, number of AF servers etc, this approach may cause overload of radio and/or core network. For in-bound roamers, the IMS nodes in HPLMN may be impacted.

Resource Reservation in EPC nodes pre MME restart/failure: Pre MME restart/failure, this approach requires reservation of the UE related resources (DAIP) in SGW.

6.1.4 Solution 4 for MME Failure by using the MME self-stored paging information

6.1.4.1 Description

This solution enables the UE to reattach to EPS triggered by downlink data packets or signalling after MME restarts. This solution includes the following steps:

- 1) The SGW maintains the IMSI and S5/S8 bearers after detection of MME restart

If the SGW detects the MME restarts by referring to restart counter, instead of removing associated resources, the SGW maintains the S5/S8 bearers. This makes it possible for the SGW to receive downlink data packets or signalling from the PGW. Which S5/S8 bearer contexts to be maintained are based on the local operator's configuration in SGW such as APN, QCI and ARP. SGW should delete bearer contexts which are not supposed maintained.

When SGW starts maintaining the S5/S8 bearers, SGW starts a timer for corresponding restarted MME. The timer value may be equal to periodic tracking area update timer (timer T3412) as specified in 3GPP TS 24.301 [4]. If the timer expires, the maintained resources shall be locally deleted.

When SGW receives the Create Session Request message for the UE while the timer is running, the SGW deletes all maintained resources for the UE and then proceeds with the Create Session Request message handling as specified in 3GPP TS 29.274 [3].

- 2) Downlink data packets or signalling arrives to the SGW while the timer in the step1) is still running.

When the SGW receives the downlink data packets on the maintaining bearer or signalling for establishing new bearers, the SGW shall reject the signalling message received from the PGW with an appropriate cause value and sends an enhanced Downlink Data Notification message including IMSI to the associated MME.

After SGW sends enhanced downlink data notification, if the corresponding Create Session Request message for this IMSI is not received within a configurable timer (which is a rather short timer), the SGW can then assume the UE has attached to other MME and other SGW, thus SGW can safely delete all maintained bearer contexts for this UE.

- 3) The MME pages the UE using S-TMSI and TAI list which were stored together with IMSI and possible other parameters in non-volatile memory before the MME restart. Such paging information (S-TMSI, TAI list, IMSI, SGW FQDN and PGW FQDN) should be kept in the non-volatile memory after MME restarts for a configurable timer e.g. Periodic TAU timer or UE is re-attached before it can release the resource. How to implement the non-volatile memory is implementation specific; this may be e.g. local MME non-volatile memory or an external backup system.

Paging information stored in an external backup system can be used when MME fails without restart. When an alternative MME in the MME pool receives the Downlink Data Notification with IMSI, it can use this stored paging information from the failed MME to page UEs. How to retrieve and utilize this paging information is implementation specific.

NOTE 1: As one of example, if the number of UEs (e.g. UEs with QCI=5 IMS PDN connections) to be recovered are 500K and 200 bytes per UE (should be sufficient to contain TAI List + STMSI + IMSI + SGW FQDN + PGW FQDN etc), the amount of paging information to be stored in non-volatile memory is about 100Mbyte uncompressed data.

- 4) For those UEs which are not yet attached to other MMEs will response the Paging message and start with Service Request procedure, the Service Request will be rejected by MME using cause codes #10 (Implicitly detached) which then trigger UE to perform a new attach procedure as specified in subclause 5.6.1 of 3GPP TS 24.301 [4]. For those UE which are attached to other MMEs will not response the paging message.

6.1.4.2 Evaluation

6.1.4.2.1 Pros

This subclause lists the pros of solution 4 as following:

EPS Service after MME Restart: This approach enables UEs to make the re-attach to the EPS possible triggered by an arrival of the downlink packet after the MME has restarted;

No inter PLMN dependency: This approach does not require any support from the EPC node across PLMNs. The approach only requires support in the SGW and MME;

No extra signalling over S11 interface: This approach requires some information to avoid sending the paging request for the UE in all the TAI lists served by the MME. However those are stored in non-volatile memories of MME, therefore there is no extra signalling message over the S11 interface in the intra MME intra SGW TAU procedure to pass those from MME to S-GW during normal operation.

No extra information in SGW: Based on the same reason above, this approach doesn't need to store extra information in SGW for normal operation which are already stored in MME.

Paging with S-TMSI in the latest TAI list: This approach performs, rather than IMSI paging, paging with S-TMSI in the latest TAI list which is stored in the non-volatile memory of MME. This approach can limit the scope/target of paging and can avoid paging in all TAI list served by the MME. This saves some radio resource. Additionally paging with S-TMSI forces UE to finally reattach to the same MME (for MME failure with restart) /SGW/PGW that are connected before MME fails.

6.1.4.2.2 Cons

This subclause lists the cons of solution 4 as following:

Resources maintained in the SGW/MME after the MME restart detection: This approach requires reservation of UE resource (S5/S8 bearer contexts) until downlink packets arrives for the UE or timer set in S-GW expires. And also IMSI, TAI list and S-TMSI are required storing in MME during normal operation.

Mobile Terminated Service which triggers the paging will fail: The SGW receives the downlink packets on the maintained bearers which will trigger the paging. However the downlink packets will be dropped by the SGW and cannot be delivered to the UE.

Non-volatile storage is required: This approach requires MME to store some information for paging UE in non-volatile storage/external system.

Require extra radio signalling: After UE receives paging with S-TMSI, extra radio signalling "Service Request and Rejection" are required before UE initiates attach process.

6.2 Alternative Solutions for SGSN failure

6.2.1 Solution 1 Down Link Data Triggered Attach (DLDTA)

6.2.1.1 Description

The Down Link Data Triggered Attach (DLDTA) is an optional feature for MME, S4-SGSN and SGW.

6.2.1.1.1 Down Link Data Triggered Attach (DLDTA) procedure

This alternative is described in the sub-clause 6.1.1.1.1 for MME failure. Refer to the sub-clause 6.1.1.1.1, with appropriate substitution of terminology as shown below.

- MME → S4-SGSN;
- TA list → RAI (No substitution is required in the ISR related procedures.);
- timer (timer T3412) as specified in the 3GPP TS 24.301 [4] → timer (timer T3312);
- UE starts the re-attach procedure as specified in subclause 5.6.2.2.2 of the 3GPP TS 24.301 [4] → UE starts the re-attach procedure as specified in subclause 4.7.9.1.2 of the 3GPP TS 24.008 [5];
- S1-MME interface → Iu PS interface.

6.2.1.2 Evaluation

This pros and cons of the solution 1 DLDTA for S4-SGSN restart is similar to the pros and cons of the solution 1 DLDTA for MME restart as specified in section 6.1.1.2.

6.2.2 Solution 2 for SGSN failure by reattachment with HSS interaction

6.2.2.1 Description

This solution is described in the sub-clause 6.1.2.1 for MME failure. Refer to the sub-clause 6.1.2.1, with appropriate substitution of terminology as shown below.

- MME → S4-SGSN;
- tracking area update timer (timer T3412) as specified in 3GPP TS 24.301 [4] → routing area update timer (timer T3312) as specified in 3GPP TS 24.008 [5];
- UE starts the re-attach procedure as specified in subclause 5.6.2.2.2 of the 3GPP TS 24.301 [4] → UE starts the re-attach procedure as specified in subclause 4.7.9.1.2 of the 3GPP TS 24.008 [5];

6.2.2.2 Evaluation

This pros and cons of the solution 2 for S4-SGSN failure by reattachment with HSS interaction is similar to the pros and cons of solution 2 for MME failure by reattachment with HSS interaction as specified in section 6.1.2.2.

6.2.3 Solution 3 Pro-active Paging based approach for S4-SGSN Failure

6.2.3.1 Description

This pro-active paging based approach for S4-SGSN failure is similar to the pro-active paging based approach for MME failure as specified in section 6.1.3.

6.2.3.2 Evaluation

This pros and cons of the pro-active paging based approach for S4-SGSN failure/restart is similar to the pros and cons of the pro-active paging based approach for MME failure/restart as specified in section 6.1.3.2.

6.2.4 Solution 4 for SGSN failure by using the SGSN self-stored paging information

6.2.4.1 Description

This solution is described in the sub-clause 6.1.4.1 for MME failure. Refer to the sub-clause 6.1.4.1, with appropriate substitution of terminology as shown below.

- MME → S4-SGSN;
- tracking area update timer (timer T3412) as specified in 3GPP TS 24.301 [4] → routing area update timer (timer T3312) as specified in 3GPP TS 24.008 [5];
- S-TMSI → P-TMSI;
- TAI list → RAI;
- UE starts the service request procedure and subsequently initial attach procedure as specified in subclause 5.6.1 of the 3GPP TS 24.301 [4] → UE starts the service request procedure and subsequently attach procedure in case of Iu Mode as specified in subclause 4.7.9.1.1 and 4.7.13 of the 3GPP TS 24.008 [5] or send any LLC frame to response paging request and subsequently attach procedure in case of A/Gb mode as specified in subclause 8.1.4 of the 3GPP TS 23.060 [7];

6.2.4.2 Evaluation

This pros and cons of the solution 4 for S4-SGSN failure by using SGSN self-stored paging information is similar to the pros and cons of solution 4 for MME failure by using MME self-stored paging information as specified in section 6.1.4.2.

6.3 Alternative Solutions for SGW failure

6.3.1 Solution 1 for SGW failure by MME/S4-SGSN re-establishing resources with a new SGW or to the old SGW after its recovery

6.3.1.1 Description

This solution enables to restore the PDN connections affected by an SGW failure with or without restart without requiring corresponding UEs to reattach to the EPS. The solution only impacts MME/S4-SGSN and PGW, and relies on the following principles:

- 1) The MME/S4-SGSN and PGW maintain the bearers and MM contexts after detection of SGW failure

Upon MME/S4-SGSN detecting an SGW failure with or without restart (relying on the restart counter or implementation, e.g. preconfigured path failure timer), the MME/S4-SGSN and PGW maintain the bearers and MM contexts for PDN connections eligible for restoration, instead of removing these resources as per existing procedures.

The PDN connections eligible for restoration are determined by the MME/S4-SGSN and PGW based on same operator's policies e.g. based on QCI, ARP and/or APN.

The MME/S4-SGSN and PGW know by local configuration whether this SGW restoration procedure is supported in the PLMN, i.e. by peer PGWs or MME/S4-SGSNs. The PGW assumes that either all or none of the MMEs/S4-SGSNs in the PLMN support this procedure.

This makes it possible for the MME/S4-SGSN to restore these bearers by selecting a new or the restarted SGW for the UE within an operator configurable period locally provisioned on MME/S4-SGSN and PGW that by default should cover the periodic TAU/RAU timer. After the expiry of such timer the MME/S4-SGSN and the PGW should delete any EPS bearer contexts that have not been relocated to a new or to the restarted SGW.

This SGW restoration procedure only applies to PDN connections established between MME/S4-SGSN and PGW of the same PLMN, i.e. for non-roaming and roaming scenarios with local breakout. Service Level Agreements may be set up to extend the use of this procedure to PDN connections established between MME/S4-SGSN and PGW pertaining to different PLMNs, i.e.; for roaming scenarios with home routed traffic, but this is further considered as out of scope of 3GPP. Consequently MME/S4-SGSN and PGW behave as per existing restoration procedure, i.e. release resources (see 3GPP TS 23.007 [2] clauses 14.1A.1 & 17.1A.1), for PDN connections established between nodes of different PLMNs, i.e. as if the remote peer does not support this SGW restoration procedure.

NOTE 1: The PGW's capability of supporting SGW failure solution is stored on per PDN, per UE by the serving MME/S4-SGSN. For the UE with multiple active PDN connections, it is possible that some of the PGWs support the SGW failure solution while others do not support the same. E.g. SGW restoration is supported for a PDN connection with local breakout while not supported for another PDN connection with home routed traffic. The existing restoration procedures upon SGW failure (see 3GPP TS 23.007 [2] clauses 14.1A.1 & 17.1A.1) apply to for the PDN connections for which the SGW restoration procedure is not supported or not applicable.

NOTE 2: The use of this procedure is restricted to PDN connections established between MME/S4-SGSN and PGW in the same PLMN to ensure, simply by local configuration, that MME/S4-SGSN and PGWs apply the same logic i.e. same operator's policies when determining whether and which PDN connections should be restored. This enables to restore in particular IMS PDN connections (even in roaming scenarios, for which local break out is used) and PDN connections of non roaming UEs.

- 2) The MME/S4-SGSN selects a new SGW or the restarted SGW for the ECM_IDLE/PMM-IDLE/GPRS STANDBY UE.

The MME/S4-SGSN should prioritize the SGW relocation for those UEs that are engaged in a Service Request or other mobility procedures, e.g. TAU/RAU/HO over the UEs that are not engaged in any mobility procedure and therefore do not have signalling connection to MME/S4-SGSN. The MME/S4-SGSN selects a new SGW or the restarted SGW for the ECM_IDLE/PMM-IDLE/GPRS STANDBY UE based on the last visited TAI/RAI. Then MME/S4-SGSN sends a Create Session Request message to the new SGW or the restarted SGW to establish the bearer contexts. The new SGW or the restarted SGW will send a Modify Bearer Request message for GTP based S5 interface or a Proxy Binding Update message for PMIP based S5 interface to the PGW to update the bearer context in the PGW. As a result of the Modify Bearer Request, the PGW may initiate signalling towards the PCRF as already specified in 3GPP TS 23.401[6]. The SGW relocation signalling corresponds to Steps 8-11 in Section 5.3.3.1 in 3GPP TS 23.401[6].

The MME/S4-SGSN should perform pro-active SGW relocation for all the UEs affected by the SGW failure, i.e. including UEs in idle mode not engaged in any Service Request or other mobility procedure. The MME/S4-SGSN controls the priority of the UEs and the pace of the pro-active SGW relocation to avoid core network node overload. This is to allow these UEs to be reconnected to the network in a relatively short time (that is function of the speed of the SGW relocations that the MME/S4-SGSN performs, based on implementation and the network load) so that downlink packets may be delivered to the UEs with minimum service interruption.

- 3) The MME/S4-SGSN releases S1/Iu/radio resources and selects a new SGW or the restarted SGW for the ECM_CONNECTED/PMM-CONNECTED/GPRS READY UE.

The MME/S4-SGSN firstly releases S1/Iu/radio resources of ECM_CONNECTED/PMM-CONNECTED/GPRS READY UE. Then the MME/S4-SGSN will handle the UE as the same way for the ECM_IDLE/PMM-IDLE/GPRS STANDBY UE. If the eNodeB detects the SGW failure or restart, the eNodeB may request the MME to release the S1-U resource.

NOTE 3: For EUTRAN or UTRAN with direct tunnel, the MME/S4-SGSN may not need to perform an explicit S1/Iu release procedure towards the eNodeB/RNC because eNodeB and RNC will also detect the SGW failure or restart.

NOTE 4: For UTRAN without direct tunnel and GERAN, the S4-SGSN may perform the SGW relocation even for UE is in PMM-CONNECTED/GPRS-READY state because S4 user plane is used. In other words the SGW restart will not be visible to the radio network.

- 4) For a UE who is in ECM-IDLE/PMM-IDLE/GPRS STANDBY state and initiates Service Request procedure, the MME/S4-SGSN shall perform the SGW relocation procedure first and then continue with Service Request procedure since MME/S4-SGSN has no valid SGW F-TEID to be included in Initial Context Setup Request towards the eNodeB or in RAB Assignment Request message towards RNC if Direct Tunnel is used.
- 5) For a UE who initiates an intra MME or an intra S4-SGSN or a periodic TAU/RAU during/after the SGW failure/restart, the MME/S4-SGSN, upon the NAS TAU/RAU Request message, performs the SGW relocation procedure. If the TAU/RAU signalling involves an MME/S4-SGSN change, and both the source and target MME/S4-SGSNs support this SGW restoration procedure, the source MME/S4-SGSN should indicate to the target MME/S4-SGSN in GTPv2 Context Response message that an SGW relocation procedure is needed due to the SGW failure/restart. Upon reception of such indication the target MME/S4-SGSN performs TAU/RAU with SGW relocation procedures. The source MME/S4-SGSN may relocate the SGW before responding to the Context Response if the target MME/S4-SGSN does not support the SGW restoration procedure, e.g. during inter-PLMN RAU/TAU procedures when the target PLMN does not support SGW restoration procedure.
- 6) The source MME/S4-SGSN rejects Handover Required/Relocation Required messages received from the RAN for UEs with PDN connection(s) affected by an earlier SGW failure that have not been restored yet; the MME/S4-SGSN then releases the S1/Iu/radio resources of these UEs to force them to enter idle mode and proceed with idle mode mobility procedures.

NOTE 5: Per step 3 above, S1/Iu/radio resources of UEs in ECM-CONNECTED/PMM-CONNECTED state affected by an SGW failure are released very shortly after the SGW failure. Therefore only very few UEs affected an SGW failure and with PDN connections not restored yet may be subject to a handover, e.g. handovers taking place just after the SGW failure before the eNB/RNC or the MME/SGSN release the S1/Iu resources. Thus it is not deemed necessary to support SGW relocation during Intra/Inter-CN handover procedures.

- 7) The PGW discards downlink packets received for a PDN connection maintained after an SGW failure that has not been restored yet. The PGW shall stop charging for PDN connections maintained after an SGW failure which have not been restored yet.

Editor's Note: potential impacts of the SGW restoration procedure to the PCC procedures are ffs. It is intended to try to hide the SGW failure to the PCRF when possible e.g. for the existing PCC rules, but it is ffs how to handle e.g. new or modified PCC rules. Besides for PMIP based S5, for which the SGW failure is visible to the PCRF, it is ffs how to restore the Gxc session when the SGW is relocated.

6.3.1.2 Evaluation

6.3.1.2.1 Pros

This subclause lists the pros of solution 1 by MME/S4-SGSN re-establishing resources with a new SGW or the restarted SGW:

Re-establishments of resources in SGW transparent to the UE: The MME/S4-SGSN performs the SGW relocation signalling within the network nodes. In other nodes, unless PGW/PCRF changes any bearer or its properties, the SGW relocation signalling due to SGW failure/restart does not require any signalling between the UE and the network.

6.3.1.2.2 Cons

This subclause lists the cons of solution 1 by MME/S4-SGSN re-establishing resources with a new SGW or the restarted SGW:

Maintained resources in the MME/S4-SGSN and PGW after SGW failure or restart detection: The MME/S4-SGSN and PGW maintain resources (MM contexts and bearer contexts) for each UE after SGW failure or restart detection during the procedure of re-establishing resources with a new or the restarted SGW in comparison with the existing requirement that the affected PDN connections are deleted. However comparing the network resources allocated for the affected UEs before and after the SGW failure or restart, the network (PGW and MME/S4-SGSN) doesn't allocate any extra resource;

SGW restoration not supported for roaming with home routed traffic: to support this scenario, the MME/S4-SGSN would need to know whether the PGW in the HPLMN supports the capability to maintain the old PDN connection after SGW failure or restarts, and vice versa; also the MME/S4-SGSN in the VPLMN and the PGW in HPLMN would need to apply the same logic or same configuration when determining which PDN connection should be maintained after detecting SGW restart. This may be supported via Service Level Agreement between PLMNs, but not further specified within 3GPP specifications.

6.3.2 Solution 2 for SGW failure by PGW initiated paging request at receiving downlink data/signalling

6.3.2.1 Description

The solution enables to restore the PDN connection of a UE that has been affected by an earlier SGW failure and not restored yet, upon receipt of downlink data packets or signalling for that PDN connection. This enables to deliver to the user terminating services such as IMS voice after an SGW failure with or without restart.

The solution may be used as supplement to solution 1 as specified in subclause 6.3.1 of this TR. The solution includes the following steps on top of the solution 1:

- 1) During normal mode of operation (i.e. before SGW failure with/without restart)

The MME/S4-SGSN supporting this solution shall include a new MME/S4-SGSN identifier IE and the SGW supporting this solution shall forward it in existing signalling over S11/S4 and S5 interfaces, i.e. in

- Create Session Request messages over S11/S4 and S5 interface during an E-UTRAN Initial Attach, a UE requested PDN connectivity, and a PDP Context Activation procedure;
- Create Session Request message over S11/S4 and Modify Bearer Request over S5 during TAU/RAU/X2 handover/Enhanced SRNS relocation procedures with a SGW change;
- Modify Bearer Request message over S11/S4 and S5 during Inter-RAT Handover procedures with/without a SGW change;
- Modify Bearer Request message over S11/S4 and S5 during Intra-RAT handover procedure with a SGW change;
- Modify Bearer Request message over S11/S4 and S5 during Inter-RAT TAU/RAU procedures without a SGW change;
- Modify Bearer Request message over S11/S4 and S5 if the message is deemed to be sent to the PGW due to other reasons, e.g. reporting ULI, time zone.
- Create Session Request message and Modify Bearer Request during X2 and Enhanced SRNS relocation ...

If the PGW receives a MBR without MME/SGSN identifier, it shall delete the stored MME/SGSN identifier.

This allows the PGW to have the serving MME/S4-SGSN address, whenever there is S5 signalling message. However, this cannot ensure that the PGW is always aware of the currently serving MME/S4-SGSN address. E.g. during inter-MME/inter-S4-SGSN HO without SGW change, the current serving MME/S4-SGSN address will not be propagated to the PGW if there is no S5 signalling.

Whether this solution is supported in the PLMN is known by local configuration. When supported in the PLMN, the PGW supporting this solution is configured with alternative(s) SGW(s) supporting this solution and the PGW assumes that all the MMEs/S4-SGSNs in the PLMN network support the solution. It is recommended that all MMEs/S4-SGSNs in the MME/S4-SGSN pool support the feature when the feature is deployed.

- 2) Downlink Data packets or signalling arrives at the PGW and the PGW detects that the corresponding PDN connection is associated with the failed SGW and has not been restored yet

For GTPv2 based S5, the following applies:

The PGW selects a SGW which supports this solution, based on local configuration, to send a PGW Downlink Triggering Notification message including IMSI, and an MME/S4-SGSN identifier when it is available, if the PDN connection receiving downlink data or signalling is eligible for PGW initiated Downlink triggering based on operator's policies, e.g. for IMS PDN Connection. The PGW should not send new PGW Downlink Triggering Notification message in very short time at receiving subsequent downlink data on the same PDN connection. It is implementation option how many times/how frequently the PGW should send PGW Downlink Triggering Notification message before discarding the downlink packets.

- NOTE 1: To ensure the delivery of downlink data, it is implementation specific whether the PGW buffers or not the downlink data until the PDN connection is restored. The application functions e.g. P-CSCF for IMS, may take care of the retransmission of the data packets.

The SGW forwards PGW Downlink Triggering Notification message to the associated MME/S4-SGSN if MME/S4-SGSN identifier is present in the PGW Downlink Triggering Notification message. If the MME/S4-SGSN identifier is not present, the SGW forwards PGW Downlink Triggering Notification message to all MME/S4-SGSN within the MME/S4-SGSN pool as known by local configuration. The SGW shall then send PGW Downlink Triggering Notification Acknowledge message back to the PGW with an acceptance cause code.

If the MME/S4-SGSN, which receives PGW Downlink Triggering Notification message including IMSI and the MME/S4-SGSN identifier, cannot find UE context corresponding to the IMSI, it shall send a PGW Downlink Triggering Notification Acknowledge message with the rejection cause code "Context Not Found", with the IMSI and the MME/S4-SGSN identifier to the SGW. The SGW then sends PGW Downlink Triggering Notification message, including IMSI only, to all MME/S4-SGSN within the MME/S4-SGSN

pool as known by local configuration. Otherwise, the MME/S4-SGSN performs S-TMSI/P-TMSI paging as per step3 below and sends PGW Downlink Triggering Notification Acknowledge message back to the SGW with an acceptance cause code.

If the MME/S4-SGSN, which receives PGW Downlink Triggering Notification message only including IMSI, cannot find UE context corresponding to the IMSI, it shall send a PGW Downlink Triggering Notification Acknowledge message only with rejection cause code, e.g. Context Not Found, to the SGW. If the MME/S4-SGSN, which receives PGW Downlink Triggering Notification message only including IMSI, can find UE context corresponding to the IMSI, it performs S-TMSI/P-TMSI paging in the step3 and sends PGW Downlink Triggering Notification Acknowledge message back to the SGW with an acceptance cause code.

The MME/S4-SGSN may expose more than one IP address on S11/S4, but the PGW Downlink Triggering Notification should be sent only once per MME/S4-SGSN per local configuration in the SGW.

The broadcasting of the paging message can be avoided by using proprietary mechanism and configuring a default MME/SGSN per vendor per pool in the SGW.

NOTE 2: The MME/S4-SGSN receiving a PGW Downlink Triggering Notification message may use proprietary mechanisms to retrieve the current serving MME/S4-SGSN of the UE and forward to it the PGW Downlink Triggering Notification, when it does not know itself the UE context corresponding to the IMSI. If so, the SGW may be configured with a default MME/S4-SGSN per vendor per pool, and send the PGW Downlink Triggering Notification message only to these default MME/S4-SGSNs instead of sending a PGW Downlink Triggering Notification message to all MME/S4-SGSNs.

For PMIPv6 based S5, the following applies:

The same principles as for GTP based S5 apply with the following differences:

- in lieu of the PGW Downlink Triggering Notification message over GTP based S5, the PGW sends over S5 an enhanced PMIP message e.g. Binding Revocation Indication with new Mobility options, e.g. Operation Indication to indicate it is PGW initiated Paging request message, the IMSI and MME/S4-SGSN Identifier when it is available.

NOTE 3: It is FFS which PMIP message over S5 interface is used for PGW downlink triggering.

Editor's Note: for PMIP-based S5, it is FFS for the impact on the PCRF, e.g. it is not possible to send the updated QoS rule since all Gateway Control sessions associated with the restarted SGW are deleted.

3) The MME/S4-SGSN performs Network Initiated Service Request procedure as specified in subclause 5.3.4.3 of 3GPP TS 23.401 [6] and in subclause 6.12.1A of 3GPP TS 23.060 [7] with the following deviations:

After the MME/S4-SGSN receives NAS message Service Request, it shall perform the SGW relocation procedure as specified in the solution 1 in subclause 6.3.1 of this TR.

6.3.2.2 Evaluation

6.3.2.2.1 Pros

The terminating services can be delivered to the idle UEs: The PGW triggered paging request upon receiving downlink data at the SGW restart or failure makes sure the terminating services can be delivered to the idle UEs.

Avoid potential signalling overload in the network due to SGW failure: This solution which based on the received downlink traffic can spread signalling traffic for restoration of EPS Service over the time. The MME/S4-SGSNs which are associated the failed SGW can make use of the Service Request, which is the result of paging request triggered by PGW, to perform SGW relocation. For those Idle UEs, e.g. without performing service request, TAU/RAU, the SGW relocation procedure could be performed until next Periodic TAU/RAU.

6.3.2.2.2 Cons

This subclause lists the cons of solution 2 by PGW initiated paging request at receiving downlink data/signalling as following:

Extra Signalling due to broadcasted paging when SGW failed: When the current MME/S4-SGSN Identifier is not available or not accurate, the SGW needs to forward the paging request without any MME/S4-SGSN

identifier to all MMEs/S4-SGSNs under the SGW, based on local configuration. The configuration between MME/S4-SGSN, SGW and PGW needs to be coordinated. The main drawback of paging broadcast is the massive increase in signalling.

Extra Processing and Memory needed in PGW during normal mode of operation: The PGW needs to process and store MME/S4-SGSN identifier per PDN connection.

PMIP Impact: the PMIP protocol need to be enhanced to let PGW send paging request message and let SGW optionally include the MME/S4-SGSN id. The Cons described above also applies to the PMIP based solution.

6.4 Alternative Solutions for PGW failure

6.4.1 Solution 1 for PGW failure with restart

6.4.1.1 Description

When the MME/S4-SGSN detects the PGW has restarted, the MME should release the PDN connections. If the UE has multiple PDN connections, the MME/S4-SGSN may send the release cause "reactivation required" to the UE. If the UE has only one PDN connections, the MME/S4-SGSN may send the release cause "explicit detach with reattach required" to the UE.

6.4.1.2 Evaluation

6.4.1.2.1 Pros

This subclause lists the pros of solution 1 for PGW failure as following:

Service recovery soon: The service will be recovered soon if the release cause "reactivation required" or "explicit detach with reattach required" is sent to UE.

6.4.1.2.2 Cons

This subclause lists the cons of solution 1 for PGW failure as following:

Possible RAN overload: When the MME/S4-SGSN detects the PGW has restarted, the MME/S4-SGSN may perform cleanup external resources including at eNodeB/RNC and UE. This may cause RAN overload.

6.4.2 Solution 2 for PGW failure without restart

6.4.2.1 Description

If the optional feature PGW Restart Notification is supported by the SGW and MME/S4-SGSN, the SGW may also send a PGW Restart Notification message to the MME or S4-SGSN if the SGW detects that a peer PGW has failed and not restarted. The PGW Restart Notification message shall include the control plane IP address of the PGW, the control plane IP address of the SGW on the S11/S4 interface and the cause value "PGW not responding". It is an implementation matter how an SGW becomes aware that a PGW has failed and has not restarted, e.g. the SGW detects a signalling path failure with the PGW for a duration exceeding the maximum path failure duration timer (see 3GPP TS 23.007 [2] clause 20.2.1).

6.4.2.2 Evaluation

6.4.2.2.1 Pros

Same as for PGW failure with restart

6.4.2.2.2 Cons

Same as for PGW failure with restart

6.5 EPC restoration procedure if the ISR is activated

6.5.1 Introduction

ISR function provides a mechanism to limit signalling during the inter RAT cell reselection for the idle mode UE, which is specified in 3GPP TS 23.401 [6]. If the ISR is activated, the MME maintains the SGSN control plane IP address and TEID, the SGSN maintains the MME control plane IP address and TEID, and the SGW maintains control plane IP addresses and TEIDs of the MME and the SGSN.

This section analyses the procedures for EPC node failure if the ISR is activated.

6.5.2 Alternative Solutions for MME/SGSN failure

6.5.2.1 Solution 1 for MME/SGSN Failure Without Restoration: Providing Complete Service in non-failed node service area

6.5.2.1.1 Description

When the MME/S4-SGSN detects that in the ISR associated CN node (i.e. S4-SGSN/MME) has restarted, the MME/S4-SGSN shall remove the restarted CN node control plane address and TEID and mark the UE context as ready for ISR deactivation. During the UE performing a common or periodic TAU/RAU, the MME/S4-SGSN shall disable the ISR by not indicate ISR activated in the TAU/RAU Accept message and inform the SGW that the ISR was deactivated in the UE as specified in 3GPP TS 23.401 [6] or 3GPP TS 23.060[7]. When receiving the TAU/RAU Accept message, the UE shall set its TIN to "GUTI" or "P-TMSI" as no ISR activated is indicated.

The non-failed MME/SGSN may initiate GUTI Relocation/P-TMSI Relocation Procedure to force the UE to perform the TAU/RAU procedure for ISR deactivation (e.g. the current TAI is not included in the new allocated TAI List during the GUTI Relocation procedure).

When the SGW detects that an in the ISR associated CN node (i.e. MME or S4-SGSN) has restarted:

1) The SGW maintains the UE contexts:

Instead of removing associated resources, the SGW maintains the UE contexts after the detection of CN node restart if ISR is activated.

When SGW starts maintaining the UE bearers, SGW starts a timer for corresponding restarted S4-SGSN/MME, e.g. ISR deactivate timer. The timer value may be equal to or bit longer than the periodic routing area update timer (timer T3312) as specified in 3GPP TS 24.008 [5] or periodic tracking area update timer (timer T3412) as specified in 3GPP TS 24.301 [4]. If the timer expires, the ISR resources (i.e. restarted CN node control plane address and TEID) shall be locally deleted. When SGW receives the Create Session Request message for the UE, the SGW deletes all maintained resources for the UE and then proceeds with the Create Session Request message handling as specified in 3GPP TS 29.274 [3]. Upon receiving indication that ISR is deactivated in the UE from MME/S4-SGSN, the SGW shall stop the timer and delete any ISR resources for the UE.

2) Downlink data packets or signalling arrives to the SGW while the timer in the step1) is still running.

When the SGW receives a downlink user plane or control plane packet on a maintained S5/S8 bearer, the SGW shall initiate the network triggered service request procedure towards the non-failed CN node as specified in 3GPP TS 23.401 [6] subclause 5.3.4.3. In addition, if the S5/S8 bearer is eligible for network initiated service restoration, the SGW shall also immediately send an enhanced Downlink Data Notification message including IMSI to the restarted CN node (i.e. S4-SGSN/ MME).

The S5/S8 bearers eligible for network initiated service restoration are determined by the SGW based on operator's policy e.g. based on the QCI and/or ARP and/or APN.

3) The restarted CN node (i.e. S4-SGSN/MME) pages the UE and forces the UE to re-attach to the network, and the normal MME/S4-SGSN pages the UE in the TAI List using S-TMSI or pages the UE in the RAI using the P-TMSI.

When UE camps in the restarted CN node related network, the paging procedure and UE behaviour upon receiving the paging message is as specified in the subclause 24 "network triggered service restoration procedure" of the 3GPP TS 23.007 [5].

When UE camps on the normal CN node related network, the UE behaviour upon receiving the paging message is as specified in subclause 5.6.1 of the 3GPP TS 24.301 [4] or subclause 4.7.9.1.1 of the 3GPP TS 24.008 [5] or subclause 8.1.4 of the 3GPP TS 23.060 [7].

For the mobility procedure with MME/SGSN restart, the behavior of ISR associated SGW and SGSN/MME is the same as the existing behavior as specified in 3GPP TS 23.401 [6].

6.5.2.1.2 Evaluation

6.5.2.1.2.1 Pros

This subclause lists the pros of solution 1 for MME/SGSN Failure without Restoration as following:

No inter PLMN dependency: This approach does not require any support from the EPC node across PLMNs. The approach only requires support in the SGW and MME/SGSN.

UE can be paged even when UE camps in the restarted MME/SGSN service area: When the SGW detects a restarted in the MME/SGSN, and the UE is activated in SGSN/MME or in idle state, SGW shall maintain the associated bearer contexts including the ISR resource. When UE camps in the restarted MME/SGSN service area, if MT service is initiated, the IMSI paging will be performed in restarted MME/SGSN side, and the UE starts the reattach procedure.

Mobile Terminated Service: When The SGW receives the downlink packets on the maintained bearers which will trigger the paging, if UE activated in the ISR associated MME/SGSN side instead of the restarted SGSN/MME side, an S-TMSI paging or P-TMSI paging will performed in the non-failed MME/SGSN side to keep the service continuity.

6.5.2.1.2.2 Cons

This subclause lists the cons of solution 1 for MME/SGSN Failure without Restoration as following:

Resources maintained in the SGW and ISR associated SGSN/MME after the MME/SGSN restart detection: This approach requires reservation of UE resource in SGW and ISR associated SGSN/MME, e.g. SGW maintains the restarted MME/SGSN control planes address and TEID the until the timer as specified in the step 1) in subclause 6.1.2.1.1 expires.

6.5.2.2 Solution 2 for MME/SGSN Failure Without Restoration: IMSI paging in all accesses

6.5.2.2.1 Description

When the SGW detects the failure of an MME or S4-SGSN for an ISR enabled UE, the SGW instead of removing all the PDN connection data should maintain the PDN connection table and MM bearer contexts for some specific S5/S8 bearer contexts eligible for network initiated service restoration procedure and initiate the deletion of the remaining S5/S8 bearer contexts. Additionally, when the SGSN detects the failure for the ISR associated CN node, the SGSN also deletes all the UE contexts.

When the SGW detects a failure in the ISR associated CN node (i.e. MME or S4-SGSN has restarted) for an UE:

- 1) The SGW maintains the UE contexts:

When SGW starts maintaining the UE bearers, SGW starts a timer for corresponding failure S4-SGSN/MME, e.g. ISR deactivate timer. The timer value may be equal to or bit longer than the periodic routing area update timer (timer T3312) as specified in 3GPP TS 24.008 [5] or periodic tracking area update timer (timer T3412) as specified in 3GPP TS 24.301 [4]. When SGW receives the Create Session Request message for the UE while the timer is running, the SGW deletes all maintained resources for the UE and then proceeds with the Create Session Request message handling as specified in 3GPP TS 29.274 [3].

- 2) Downlink data packets or signalling arrives to the SGW while the timer in the step1) is still running.

When the SGW receives a downlink user plane or control plane packet on a maintained bearer, the SGW shall send an enhanced Downlink Data Notification message including IMSI to both the ISR associated CN nodes (i.e. S4-SGSN/ MME) associated for the UE.

- 3) The CN nodes (i.e. S4-SGSN/MME) page the UE and force the UE to re-attach to the network.

The paging procedure and UE behavior upon receiving the paging message is as specified in the subclause 24 "network triggered service restoration procedure" of the 3GPP TS 23.007 [5].

6.5.2.2.2 Evaluation

6.5.2.2.2.1 Pros

This subclause lists the pros of solution 2 for MME/SGSN Failure without Restoration as following:

No inter PLMN dependency: This approach does not require any support from the EPC node across PLMNs. The approach only requires support in the SGW and MME/SGSN.

UE can be paged even when UE camps on the failed MME/SGSN: When the SGW detects a failure in the MME/SGSN, and the UE is activated in SGSN/MME or in idle state, SGW shall maintain the associated bearer contexts including the ISR resource. If MT service is initiated, the IMSI paging will be performed in the both in MME and SGSN, and the UE starts the reattach procedure.

Implementation Complexity in SGW: The SGW behaves uniformly towards both failed node and the non-failed node. This reduces the implementation complexity of SGW.

6.5.2.2.2.2 Cons

This subclause lists the cons of solution 2 for MME/SGSN Failure without Restoration as following:

Mobile Terminated Service Interruption: When The SGW receives the downlink packets on the maintained bearers which will trigger the paging, the UE is forced to reattach even if the UE is in the area of non-failed node. Thus UE service may be impacted.

6.5.2.3 Solution 3 for MME/SGSN Restart: TMSI paging in both accesses

6.5.2.3.1 Description

When the MME/S4-SGSN detects a restart in the ISR associated CN node (i.e. S4-SGSN/MME), the MME/S4-SGSN shall remove the failed CN node control plane TEID, maintain the IP address of the failed CN node and mark the UE context as ready for ISR deactivation. During the UE performing a common or periodic TAU/RAU, the MME/S4-SGSN shall disable the ISR by not indicate ISR activated in the TAU/RAU Accept message which is a regular ISR functionality as specified in 3GPP TS 23.401 [6] or 3GPP TS 23.060[7]. When receiving the TAU/RAU Accept message, the UE shall set its TIN to "GUTI" or "P-TMSI" as no ISR activated is indicated. Upon receiving the ISR disabled indication from MME/S4-SGSN, the SGW shall delete any ISR resources for the UE which is a regular ISR functionality as specified in 3GPP TS 23.401 [6].

NOTE: The MME/S4-SGSN may initiate GUTI/P-TMSI relocation procedure with new TAI list/ RA to trigger the UE to perform TAU/RAU procedure.

When the SGW detects a restart in the ISR associated CN node (i.e. MME or S4-SGSN) for an UE:

- 1) The SGW and the normal healthy CN node maintain the UE contexts:

The SGW removes the IP address and TEID of the failed CN node and maintains other UE contexts after the detection of CN node restart if ISR is activated. Note that the SGW still maintains the ISR status and start a timer. If the timer expires, the ISR status shall be removed.

The normal healthy CN node removes the TEID of the failed CN node and maintains the IP address of the failed CN node and other UE contexts after the detection of the CN node restart if ISR is activated. When the

IP address of the failed CN node is maintained in the normal healthy CN node, the normal healthy CN node starts a timer (e.g. ISR deactivate timer).

- 2) Downlink data packets and signalling arrive at the SGW while the timer in the SGW in the step1) is still running.

When the SGW receives a downlink user plane or control plane packet on a maintained bearer, the SGW shall send normal Downlink Data Notification message to the normal healthy CN node (i.e. S4-SGSN/MME). The healthy CN node sends the Context Transfer and Paging Triggering message to the failed CN node.

- 3) The failed CN node and normal healthy CN node (i.e. S4-SGSN/MME) pages the UE in the TAI List using S-TMSI or pages the UE in the RAI using the P-TMSI.

The S-TMSI and TAI list, or P-TMSI and RAI is stored in the external back-up system or the non-volatile memory. The UE behavior upon receiving the paging message is as specified in subclause 5.6.1 of the 3GPP TS 24.301 [4] or subclause 4.7.9.1.1 of the 3GPP TS 24.008 [5] or subclause 8.1.4 of the 3GPP TS 23.060 [7].

If the UE camps on the failed CN node related side and the Service Request will be received by the failed CN node, the failed CN shall perform an authentication procedure and send an Update Location Request to HSS to retrieve the subscriber data. The ISR should be maintained by sending Modify Bearer Request with ISR activated from the failed node to the SGW if the UE camps on the failed CN related side. If the UE camps on the healthy CN node related side, the ISR may be deactivated in the next TAU/RAU accept message.

6.5.2.3.2 Evaluation

6.5.2.3.2.1 Pros

This subclause lists the pros of solution 3 for MME/SGSN Failure without Restoration as following:

No inter PLMN dependency: This approach does not require any support from the EPC node across PLMNs. The approach only requires support in the SGW and MME/SGSN.

UE can be paged even when UE camps on the failed MME/SGSN: When the SGW detects a failure in the MME/SGSN, and the UE is activated in SGSN/MME or in idle state, SGW shall maintain the associated bearer contexts including. When UE camps on the failed MME/SGSN, if MT service is initiated, the TMSI paging will be performed in the both in MME and SGSN, and the UE starts the Service Request procedure.

Continuity of Mobile Terminated Service: When The SGW receives the downlink packets on the maintained bearers which will trigger the paging, if UE activated in the failed SGSN/MME, a S-TMSI paging or P-TMSI paging will be performed to keep the service continuity.

6.5.2.3.2.2 Cons

This subclause lists the cons of solution 3 for MME/SGSN Failure without Restoration as following:

Resources maintained in the SGW and ISR status after the MME/SGSN restart detection: This approach requires reservation of UE resource in SGW and ISR status until the timer as specified in the step 1) in subclause 6.5.2.3.1 expires.

Non-volatile storage is required: This approach requires MME/S4-SGSN to store some information for paging UE in non-volatile storage/external system.

Complexity is added: This approach requires supporting new GTPv2 procedures to transfer the context and trigger the paging; this approach also additionally requires new HSS interaction for UE subscription data retrieval.

6.5.3 Alternative Solutions for SGW failure

6.5.3.1 Solution 1 for SGW failure: Deactivated ISR state

6.5.3.1.1 Description

When the MME detects a SGW restart and if ISR is activated, the MME behaves as described below:

- For ECM-CONNECTED state UEs: The MME should perform the GUTI Reallocation procedure with a new TAI list as specified in 3GPP TS 23.401 [6] and the UE will initiate a TA U procedure during which ISR can be deactivated in the UE. At this point, the MME also deactivates ISR locally. The MME may send (newly defined) "UE Active RAT Notification" message over S3 interface to S4-SGSN. On reception of this message, the S4-SGSN releases the UE session locally. The MME also removes the S4-SGSN S3 control plane address and TEID. Then the MME performs the restoration procedure as specified in subclause 6.3.
- For the ECM-IDLE state UEs: The MME shall first page the UE to bring the UE to ECM-CONNECTED. If the paging is successful and the UE enters the ECM-CONNECTED state, the MME follows the procedure defined for ECM-CONNECTED state UEs to complete the SGW restoration. If paging the UE fails, the MME should adjust its paging retransmission strategy (e.g. limit the number of short spaced retransmissions) to take into account the fact that the UE might be in GERAN/UTRAN coverage. If the MME receives "UE Active RAT Notification" from S4-SGSN, the MME releases the UE session locally. Otherwise after retrying the paging procedure, the MME may release the PDN connection context and UE MM context assuming the UE is in GERAN/UTRAN coverage area.

NOTE: The MME should only perform the SGW reselection for the UEs camping on the LTE, ISR activated UEs may camp in the 2G/3G, so paging is needed.

When the S4-SGSN detects a SGW restart and if ISR is activated, the S4-SGSN behaves as described below:

- For PMM-CONNECTED state UEs: The S4-SGSN should perform the P-TMSI Reallocation procedure with a new RAI as specified in 3GPP TS 23.060 [7] and the UE will initiate a RAU procedure during which ISR can be deactivated in the UE. At this point, the S4-SGSN also deactivates ISR locally. The S4-SGSN may send (newly defined) "UE Active RAT Notification" message over S3 interface to MME. On reception of this message, the MME releases the UE session locally. The S4-SGSN also removes the MME S3 control plane address and TEID. The S4-SGSN then performs the restoration procedure as specified in subclause 6.3.
- For the PMM-IDLE UEs: The S4-SGSN shall first page the UE to bring the UE to PMM-CONNECTED. If the paging is successful and the UE enters the PMM-CONNECTED state, the S4-SGSN follows the procedure defined for PMM-CONNECTED state UEs to complete the SGW restoration. If paging the UE fails, the S4-SGSN should adjust its paging retransmission strategy (e.g. limit the number of short spaced retransmissions) to take into account the fact that the UE might be in E-UTRAN coverage. If the MME receives "UE Active RAT Notification" from MME, the S4-SGSN releases the UE session locally. Otherwise after retrying the paging procedure, and the S4-SGSN may release the PDN connection context and UE MM context assuming the UE is in E-UTRAN coverage area.

6.5.3.1.2 Evaluation

6.5.3.1.2.1 Pros

This subclause lists the pros of solution 1 for SGW failure as following:

EPS Service after SGW failure: This approach enables to re-select a new SGW after the failure of the SGW.

6.5.3.1.2.2 Cons

This subclause lists the cons of solution 1 for SGW failure as following:

Maintained resources in the MME/SGSN and PGW after SGW failure detection: The MME/SGSN and PGW maintain related bearer resources after SGW failure detection during the procedure of re-establishing resources with a new SGW.

PLMN dependency for inbound roaming UE: The MME/SGSN needs to know whether the PGW in the HPLMN supports the capability to maintain the old PDN connection after SGW failure, vice versa.

Possible overload of Radio and Core Network Nodes: When the MME/SGSN detects a failure of SGW, the MME/SGSN shall page all the related idle UE anchored in the failure SGW, this approach may cause overload of radio and core network. Additionally, if the MME/S4-SGSN sends "UE Active RAT Notification" message over S3 interface, it may lead to overload of S4-SGSN/MME.

6.5.3.2 Solution 2 for SGW failure: Maintain the ISR state

6.5.3.2.1 Description

This solution proposes to maintain the ISR state for those ISR activated UEs after an SGW restart or failure. The solution includes the following steps as illustrated in the following figure 6.5.3.2.1, which are on top of Solution 1 for SGW failure by MME/S4-SGSN re-establishing resources with a new SGW as described in section 6.3.1:

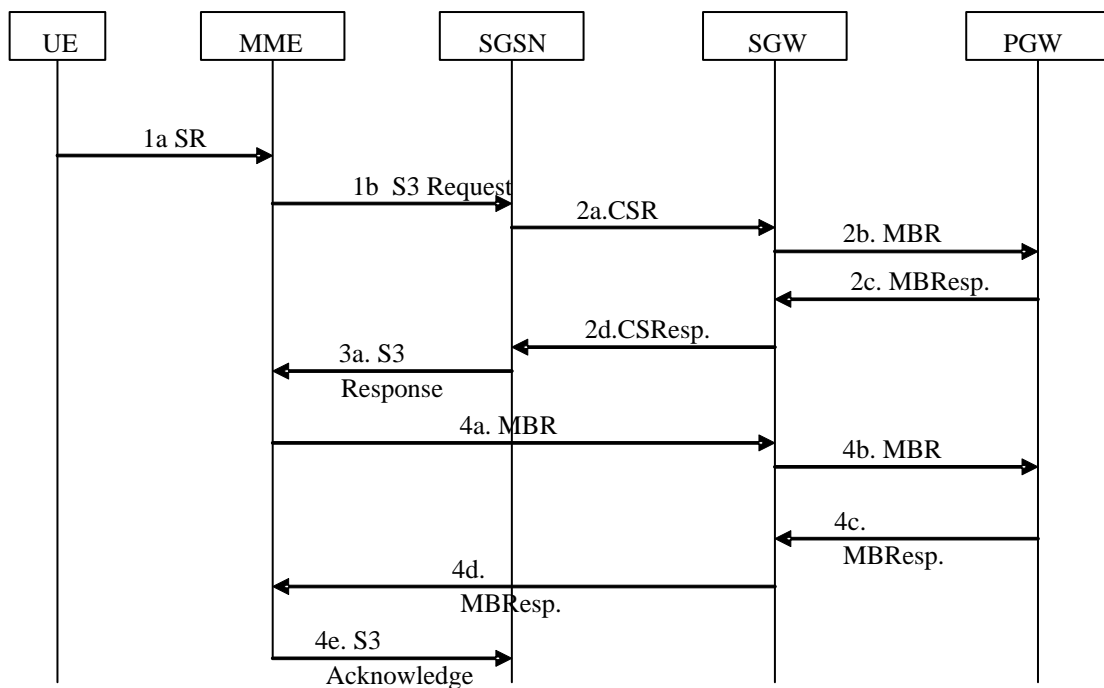

Figure: 6.5.3.2.1-1

- 1) (1a, 1b) When the MME or the S4-SGSN receives uplink NAS message from UE, e.g. Service Request, it performs SGW selection procedure and then it sends an S3 message carrying the new SGW's FQDN as result of SGW selection procedure to the other mobility management node (S4-SGSN or MME) where the ISR was activated. The capability to support this solution shall be negotiated between the MME and S4-SGSN beforehand.
- 2) (2a, 2b, 2c and 2d) The ISR associated mobility management node then sends a GTPv2 Create Session Request message to the SGW selected as part of SGW relocation procedure.
- 3) (3a) When the ISR associated mobility management node receives the GTPv2 Create Session Response message as result of SGW relocation procedure, it sends an S3 message to the other ISR associated node to indicate the SGW has been selected. When there is any failure during SGW relocation, e.g. receiving the rejection in the Create Session Response, the ISR associated mobility management node indicates that failure in the S3 message and the ISR is going to be deactivated, so that the other ISR associated node, i.e. the mobility management node that receives uplink NAS message, continues the step below without activating ISR, i.e. not sending the S3 message to indicate ISR activated to the ISR associated node.

4) (4a, 4b, 4c, 4d and 4e) The other ISR associated node, i.e. the mobility management node that receives uplink NAS message sends Modify Bearer Request message based on Step 9 of section 5.3.3.2 of 3GPP TS 23.401 [6] or Step 7 of section 5.3.3.3 of 3GPP TS 23.401 [6] to activate ISR. After that, the node sends an S3 message to the ISR associated node to indicate ISR has been activated.

NOTE 1: The S3 message that carries SGW FQDN and F-TEID information as well as its response message can either be the existing ones or new messages that may allow carrying necessary ISR information for multiple UEs. It is up to Stage-3 to decide.

During/after the SGW failure/restart, if the UE does a inter MME/S4-SGSN TAU/RAU to a new MME/S4-SGSN, where ISR cannot be activated, ISR needs to be deactivated in both old MME and old S4-SGSN. After the either the old MME or the old S4-SGSN transferred the UE context to the new MME or S4-SGSN, the old MME/S4-SGSN informs the old ISR associated mobility management node, to deactivate ISR and remove the PDN connections of the UE.

NOTE 2: The new S3 messages may need to allow the old MME or S4-SGSN to inform the old ISR associated mobility management node, to deactivate ISR and remove the PDN connections of the UE. This new message may reuse the one introduced in the step 1.

During/after the SGW failure/restart, if the MME/S4-SGSN received a PGW Downlink Triggering Notification containing MME Identifier or S4-SGSN Identifier from the PGW (relayed by a SGW) for those UEs of which PDN Connections are associated with failed SGW, in this case, either MME or S4-SGSN will receive PGW Downlink Triggering Notification, the MME or the S4-SGSN shall proceed the paging and also forward the page request over S3 interface to the ISR associated node; if the MME/S4-SGSN received a PGW Downlink Triggering Notification without MME or SGSN Identifier, which means the SGW has broadcasted the paging request from the PGW, therefore both the MME and S4-SGSN will receive PGW Downlink Triggering Notification, the MME and S4-SGSN shall perform the paging independently. Upon receiving the Service Request as the result of paging, either the MME or the S4-SGSN starts the SGW relocation procedure together with the above steps 1 in addition. For rest of affected UEs which don't perform TAU/RAU or Service request initially, and no downlink data for them, the MME/S4-SGSN can wait to relocate a new SGW together with the above steps 1 in addition, until the UEs perform Periodic TAU/RAU.

6.5.3.2.2 Evaluation

6.5.3.2.2.1 Pros

This subclause lists the pros of solution 2 SGW failure: Maintain the ISR state as following:

EPS Services can be delivered to those ISR activated UE: The solution solves problem that ISR state is unsynchronized between network and UE, and it makes sure that EPS Services can be delivered to those ISR activated UEs which have been relocated to a new SGW.

6.5.3.2.2.2 Cons

This subclause lists the cons of solution 2 SGW failure: Maintain the ISR state as following:

Extra Signalling introduced in the network: Extra signalling over S3 to request the ISR associated mobility management node to select the same SGW to maintain ISR activated for each affected UEs due to SGW restart or failure; Extra signalling over S3 to request the ISR associated mobility management node to remove UE context when UE has moved to another MME or S4-SGSN. Extra signalling over S5/Gx to report the RAT change during re-activate ISR. However it reduces signalling over Radio and Core Network when UE perform next TAU/RAU.

Increasing the latency for the NAS procedures: Because of CN signalling to re-establish ISR, the latency for the NAS procedures, e.g. the service request and the TAU is increased, UE may need to re-try the same procedure if the timers, e.g. T3410(15s), T3417(5s), are expired.

6.5.3.3 Solution 3 for SGW failure with ISR

6.5.3.3.1 Description

The solution 3 enables the mobile terminating service such as IMS voice or mobile originating service can be delivered even after SGW failure or restart.

The solution could be used as standalone solution to the SGW failure with ISR including the following steps:

6.5.3.3.1.1 Mobile Terminating service handling.

The solution makes it possible that the mobile terminating service such as IMS voice could be delivered to the UE even after SGW failure with or without restart. The solution includes the following steps:

- 1) The MME/S4-SGSN supporting the PGW triggered SGW restoration procedure shall include the MME/S4-SGSN identifier IE in existing signalling over the S11/S4 interface:

This step handling can be referred to solution 2 for SGW failure without ISR in subclause 6.3.2.

- 2) Downlink Data packets or signalling arrives at the PGW

This step handling can be referred to solution 2 for SGW failure without ISR in subclause 6.3.2. In addition, if the MME/S4-SGSN received a PGW Downlink Triggering Notification message containing MME Identifier or S4-SGSN Identifier from the SGW for those UEs of which PDN Connections are associated with failed SGW, the MME/S4-SGSN shall process the PGW Downlink Triggering Notification message and send the Paging Indication message (newly defined) over S3 interface to the ISR associated S4-SGSN/MME over the existing GTP-C tunnel between S4-SGSN and MME

The ISR associated S4-SGSN/MME, which receives Paging Indication message, performs P-TMSI/S-TMSI paging in the step3.

- 3) The MME and S4-SGSN perform Network Initiated Service Request procedure as specified in subclause 5.3.4.3 of 3GPP TS 23.401[6] and in subclause 6.12.1A of 3GPP TS 23.060[7] with the following:

After the MME/S4-SGSN receiving NAS message Service Request, the MME/S4-SGSN may send "ISR deactivation Indication" (newly defined) message to the ISR associated S4-SGSN/MME and the MME/S4-SGSN shall perform the GUTI/P-TMSI Reallocation procedure with a new TAI list/RAI as specified in 3GPP TS 23.401 [6] and 3GPP TS 23.060 [7] and the UE will initiate the TAU/RAU procedure during which ISR can be deactivated in the UE. At this point, the MME/S4-SGSN also deactivates ISR locally. On reception of the "ISR deactivation Indication" message, the ISR associated S4-SGSN/MME releases the UE sessions locally. The MME/S4-SGSN then start the SGW restoration procedure as specified in subclause 6.3.

6.5.3.3.1.2 Mobile Originating Service handling

- 1) When receiving the UE initiated TAU Request/RAU Request message, if it is intra MME/S4-SGSN TAU/RAU, the MME/S4-SGSN performs the SGW relocation procedure as specified in subclause 6.3, and informs the UE in the related TAU/RAU Accept message to disable ISR as specified in 3GPP TS 23.401[19] and 3GPP TS 23.060 [5]. Else if the MME/S4-SGSN is changed, the ISR shall be deactivated in the UE by the new MME/S4-SGSN, and the old MME or the old S4-SGSN notifies the new MME or S4-SGSN to perform the SGW relocation procedure as specified in subclause 6.3.
- 2) When receiving the UE initiated Service Request message, the MME/S4-SGSN performs the SGW relocation procedure as specified in subclause 6.3, and initiates the GUTI Relocation or P-TMSI Relocation Procedure with a non-broadcast TAI or RAI to force the UE to perform the TAU/RAU procedure for ISR deactivation.
- 3) SGW relocation in Handover procedure is handled according to the definition in subclause 6.3, and the ISR will be deactivated in the UE during the Service request/TAU/RAU procedure as described in the above steps.

In these MO procedures, the MME/S4-SGSN may send "ISR deactivation Indication" message to the ISR associated S4-SGSN/MME to deactivate ISR and remove the UE sessions.

6.5.3.3.2 Evaluation

6.5.3.3.2.1 Pros

The mobile terminating services can be delivered to the idle UEs : The PGW triggered paging request upon receiving downlink data at the SGW restart or failure makes sure the terminating services can be delivered to the idle UEs.

Avoid potential signalling overload in the network due to SGW failure: This solution which based on the received downlink traffic can spread signalling traffic for restoration of EPS Service over the time. The MME/S4-SGSNs which are associated the failed SGW can make use of the Service Request, which is the result of paging request triggered by PGW, to perform SGW relocation. For those Idle UEs, e.g. without performing service request, TAU/RAU, the SGW relocation procedure could be performed until next Periodic TAU/RAU.

The mobile originating services will be not affected: The MME/S4 SGSN performed SGW relocation procedure and triggered the UE deactivate the ISR state on receiving the NAS message.

6.5.3.3.2.2 Cons

Extra Signalling introduced in the network: Extra signalling over S4/S11 interface when the SGW forwards paging request without MME/S4-SGSN identifier from PGW. Extra signalling over S3 to request the ISR associated mobility management node to page the UE.

Extra Processing and Memory needed in PGW during normal mode of operation: The PGW needs to process and store MME/S4-SGSN identifier per PDN connection.

6.5.3.4 Solution 4: Preconfigured Node to restore SGW

6.5.3.4.1 Description

The solution is based on Solution 1 of SGW restoration without ISR. This involves MME or SGSN sending Create Session Request proactively to new SGW which then in turn sends Modify Bearer Request to PGW. The SGW and PGW behave as if inter-SGW HO has occurred. However because ISR is active, the UE may be in SGSN or MME service area and may trigger Service Request for uplink data. If the UE is not in the node which in triggering Create Session Requests then handling of such a request is tricky as a race condition can occur which can cause the PGW to receive modify Bearer Requests from 2 different SGW's one chosen by MME and other chosen by SGSN. The solution below describes how to resolve the race condition:

1) Configuration:

The operator configures either the MME or SGSN to take lead of choosing SGW and sending the Create Session Requests. For ease of description we call such a node configured to initiate SGW restoration as Configured Node and the other ISR associated node as Non-configured node.

2) Restoration by Configured Node:

When SGW failure is detected and Service Restoration procedure is triggered, the Configured Node initiates the process of SGW restoration as described in Solution 1 for non-ISR case (section 6.3.1). Additionally when ISR is activated, the Configured Node sends an S3 message carrying the new SGW's FQDN and the S4/S11 SGW F-TEID information to the other mobility management node (S4-SGSN or MME) where the ISR was activated.

When SGW failure is detected by the MME/SGSN and PGW, the MME/SGSN and PGW start a timer for all the PDN connections impacted by the failure. Upon expiry of the timer, the MME/SGSN and PGW shall delete all the non-restored PDN connections.

3) Handling of UE initiated Service Request Procedure and TAU/RAU procedure:

During the time between SGW failure and SGW Restoration, there is a possibility that UE triggers a service request procedure and/or TAU/RAU procedure. If the UE is in the service area of the Configured Node, the node behaves as described in Step 1 of Section 6.5.3.2.1 (i.e. it relocates the SGW before informing the non-Configured node of SGW FQDN etc).

If the UE is in the service area of non-Configured Node, the non-Configured Node rejects the NAS signalling with 'Cause #9: UE Identity cannot be derived by the network' which triggers the UE to reattach.

Additionally, the Non-Configured Node sends Detach Notification with cause 'Complete Detach' to the Configured Node. This triggers the Configured Node to locally delete the UE context. If the SGW restoration is completed for such a UE, the Configured Node shall delete the PDN connections for the UE. The PDN connections for such UEs which have been locally deleted will remain in PGW till the timer configured (as defined in step 1 of 6.3.1.1) expires. If the Configured Node has already restored the session when it receives the Detach Notification, the Configured Node should send Delete Session Request to clean up the PDN connections.

When an ISR enabled UE performs an inter-SGSN RAU or inter-MME TAU procedure, the context request for an RAU is sent to the ISR associated SGSN while the context request for TAU is sent to ISR associated MME. If the context request is received by the Non-Configured Node before the SGW restoration is completed by Configured Node, the context request should be rejected by the non-Configured Node with cause 'context not found'. This forces the UE to reattach in the target node. Additionally, the non-Configured Node also sends Detach Notification to the Configured Node as described earlier.

If the context request is received by the Configured Node before the SGW restoration is completed, the context response contains an indication specifying that the 'SGW Restoration is pending'. This indication will ensure that the target node will restore the SGW before accepting RAU/TAU. Additionally, the Configured Node should not indicate 'ISR capability', thus forcing the UE to be ISR disabled after the TAU/RAU procedure. In such a case the Configured Node deletes the UE context (as described in TAU procedure of 23.401 or RAU procedure of 23.060). However the UE context in the Non-Configured Node is deleted only after the SGW Restoration timer expires (as described in step 1).

6.5.3.4.2 Evaluation

6.5.3.4.2.1 Pros

This subclause lists the pros of solution 6.5.3.4 as following:

Minimized interruption of Network Triggered Services: When the SGW fails the MT services are impacted as UP packets cannot be tunneled to eNodeB. However, when MME or SGSN triggers the service restoration by relocating SGW, the service interruption is reduced..

6.5.3.4.2.2 Cons

This subclause lists the cons of solution 4 as following:

Some UEs are forced to reattach: When the UEs initiate Service Request in non-Configured Node, the UE is forced to reattach which delays the UE initiated service request by the duration required for re-attach. However this only happens for those UEs which are ISR enabled UEs and which are impacted by SGW failure and which initiate UE initiated Service Request before the Configured Node could trigger SGW restoration. This leads to a delay in MO service request for such UEs.

Hanging PDN connections: It is possible that the same PDN GW is not chosen by the non-configured node. In this case the old PDN GW will be left with some hanging PDN connections which will have to be deleted by having a idle timer.

MT Call service interruption: The MT services cannot be delivered to the UE for the period between the SGW failure and SGW restoration by configured node or service request by the UE.

6.6 Restoration of CS services after MME failure

6.6.1 Introduction

This clause investigates possible solutions preventing failure of Mobile Terminated CS services upon an MME failure without restart or restarting after delay. See clause 5.2.3.1 "Outage of CS services".

6.6.2 Alternative Solutions for Restoration of CS services after MME failure

6.6.2.1 Solution 1 – MT CS services delivery via an alternative MME in MME pool

6.6.2.1.1 Description

This solution enables the network to continue delivering MT CS services (e.g. CSFB or SMSoSsGs) to UEs via an alternative MME in the MME pool where the UE is located.

This solution includes the following steps:

- 1) The VLR gets the knowledge of the identities of alternative MMEs in the MME pool.

During normal operations, the VLR may learn the set of MMEs pertaining to the same MME pool by checking the MME Group ID within the MME name that MMEs signal to the VLR in the SgsAP-LOCATION-UPDATE-REQUEST, SgsAP-RESET-INDICATION or SgsAP-RESET-ACK messages..

Alternatively the VLR may be pre-configured with the set of MME identities pertaining to the same MME pool.

- 2) Upon receipt of mobile terminated CS services (e.g. CS call), the VLR selects one of these alternative MMEs if it detects that the MME serving the UE is no longer in service and sends a Sgs paging request to this (single) alternative MME with a new 'restoration indicator' flag in the message. The VLR should load-balance the paging requests among the available MMEs in the pool during the restoration procedure.

The VLR may detect that an MME is no longer in service if there is no more SCTP associations in service with that MME.

NOTE 1: Semi-permanent SCTP associations shall be established between the MME and VLR, i.e. the SCTP associations shall remain up under normal circumstances .

The VLR includes a new 'restoration indicator' flag in the Sgs paging request it sends to the alternative MME to force the receiving MME to accept the Sgs paging request and to proceed with the CSFB or SMS procedure even if the IMSI is unknown to this MME and even if the MME has not restarted recently , i.e. even in the 'MME-reset = false' state.

NOTE 2: Without the new 'restoration indicator', the receiving MMEs (not having restarted recently) would reject the Sgs paging requests, as per existing specifications, for unknown UEs.

NOTE 3: This restoration procedure (MT CS services delivery via an alternative MME in MME pool) works regardless of whether the VLR has restarted recently or not. In the former case, the restarted VLR initiates the existing CS restoration procedure upon receipt of the mobile terminated CS service, during which it retrieves the identity of the MME where the UE is currently registered; if the VLR detects that this MME is no longer in service, it selects an alternative MME to deliver the CS service.

NOTE 4: The VLR needs to adjust its paging retransmission delay to avoid requesting again the UE to re-attach before the restoration procedure completes.

- 3) Upon receipt of an Sgs paging request including the new 'restoration indicator' flag, the MME proceeds with the existing procedures specified in 3GPP TS 29.118 [9] in clause 5.1.3 for the case where it has restarted recently, but regardless of its own 'MME-reset' value:

- if the Sgs PAGING-REQUEST message includes the Location area identifier information element, the MME shall page the UE in all the tracking areas served by the MME that can be mapped to the location area indicated in the Location area identifier information element; or
- if the SgsAP-PAGING-REQUEST message does not include the Location area identifier information element, the MME may either page the UE in all the tracking areas served by the MME or in the tracking areas served by the MME and by the VLR, or reject the paging request per operator policy.

The MME initiates the paging procedure using IMSI with the CN domain indicator set to "PS" to request the UE to re-attach as described in 3GPP TS 24.301 [4].

NOTE 5: Paging the UE with the CN domain indicator set to "CS" would lead the UE to send an Extended Service Request procedure that would be forwarded to the MME that had allocated the UE's S-TMSI or, if not in service, that would be rejected with a cause leading the UE to re-attach. Besides, CSFB with IMSI paging would not allow GERAN to route the paging response (including IMSI) to the right MSC/VLR if Intra Domain Connection of RAN Nodes to Multiple CN Nodes is deployed for GERAN (see 3GPP TS 23.236 [11]).

4) The UE initiates the attach procedure to one MME of the pool (that may not be necessarily the MME that initiated the paging procedure towards the UE). During that procedure, the MME establishes a new SGs association with the VLR. This may be a different VLR than the VLR that initiated the SGs paging procedure, e.g. if Intra Domain Connection of RAN Nodes to Multiple CN Nodes is deployed for GERAN or UTRAN (see 3GPP TS 23.236 [11]).

NOTE 6: In the specific circumstance where the SCTP associations failure between a VLR and an MME is due to reasons other than the MME being down (e.g. IP network failure), i.e. where the UE is still served by the original MME (MME 1), this step leads a UE in idle mode to re-attach to the network and thus to some slight extra signalling in the network. A UE in connected mode would not respond to the paging request, i.e. on-going PS sessions would not be interrupted or handed over to 2G/3G and the MT CS service would not be delivered to the UE. This scenario remains unlikely thanks to SCTP multihoming (i.e. the ability for a single SCTP endpoint to support multiple IP addresses, allowing each side to be connected to the other through different physical interfaces and/or different IP networks). The VLR may also start delivering MT CS services via an alternative MME only after the SCTP failure exceeds a minimum duration.

5) If the new SGs association is established towards the same VLR, that VLR can repeat the SGs paging request after the UE has re-attached to non-EPS services. The MT CS service or SMS is then delivered according to existing procedures (nominal scenario).

If the new SGs association is established towards a different VLR, the MT CS service may be delivered via the new VLR using Mobile Terminating Roaming Retry or Mobile Terminating Roaming Forwarding (see 3GPP TS 23.018 [10]); the on-going MT SMS is retransmitted by the SMS-SC using the existing SMS procedures (SMS alert).

Subsequent MT CS services are delivered as per existing nominal procedures.

The procedure is illustrated in the following figure.

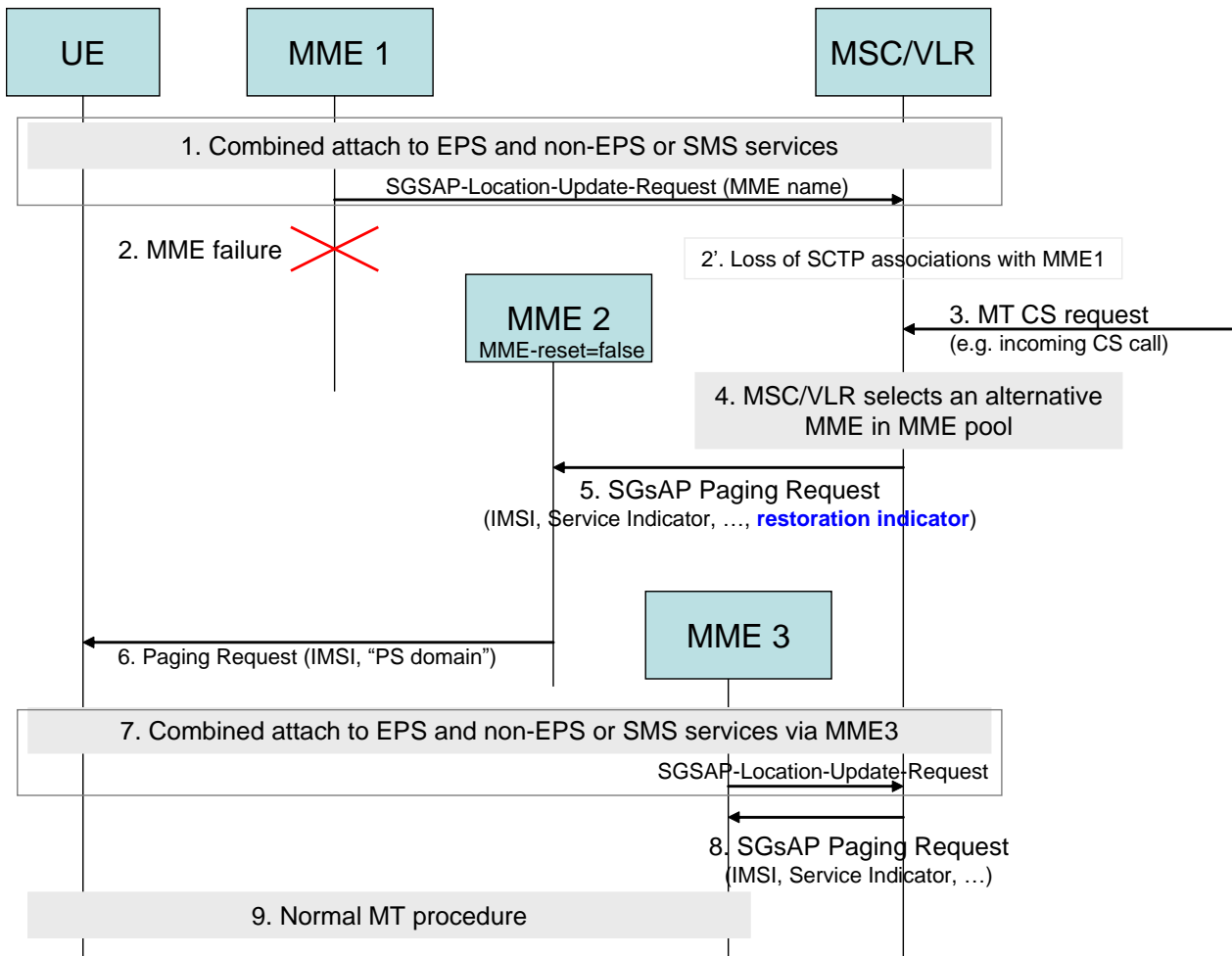

Figure 6.6.2.1.1-1: MT CS services delivery via an alternative MME in MME pool

NOTE 7: Steps 1 and 7 in the figure cover the complete attach procedure for EPS and non-EPS services (including TMSI reallocation if the VLR allocates a new TMSI) as specified in subclause 5.2 of 3GPP TS 23.272 [8], although only a subpart of the procedure is depicted in the call flow for the sake of clarity.

NOTE 8: A UE with ISR active before the MME failure and using GERAN or UTRAN radio access will not receive the paging request sent by a restarted or alternative MME. The VLR can deliver the MT CS service by paging the UE on the A/Iu interface as per existing principles of 3GPP TS 29.118 [9] when the UE does not respond to a first paging on the SGs interface. Paging the UE on the A interface fails if the network operates in NMO I and the UE is in PS connected mode in GERAN.

6.6.2.1.2 Evaluation

6.6.2.1.2.1 Pros

MT CS Service after MME Restart: This approach enables the network to deliver CS services via EPS/LTE via an alternative MME in the MME pool;

Minimal impacts in VLR and MME: This solution has minimal impacts on the MME (essentially one new 'restoration flag' to support, which if received lead to apply existing procedure when IMSI is unknown and MME-reset = false) and small VLR impacts (sending SGs paging request to an alternative MME);

6.6.2.1.2.2 Cons

First MT CS call may fail: The first MT CS call fails if during the re-attachment of the UE the SGs association is established with a different VLR and MTRF/MTRR is not supported.

6.7 Detection of EPC Node failure without Restart

6.7.1 Introduction

This clause investigates possible solutions to detect EPC node failure without restart.

6.7.2 Solution 1 – Using Path Management messages

6.7.2.1 Description

The method describes the SGW detection of the MME failure without restart. The SGW and MME nodes are used as an example for the simplicity of understanding. In general, the same method can be used by any GTPv2 control plane entity to detect the failure of the peer node without restart, with replacement of relevant terminology.

Following counters and configurations at the SGW are used for this method.

T-Echo-Interval: The time interval between two echo request messages over S11 interface. This parameter is configured at the SGW.

N-Echo-Failure: Per MME N-Echo-Failure counter is maintained by the SGW to count the consecutive number of echo request failure, which are not responded by the MME.

N-MME-Max-Echo-Failure: This is maximum allowed consecutive echo request failure (i.e. echo requests which are not responded by the MME), per MME before the MME can be considered as failed without restart. This value is configured at the SGW depending upon the Echo-Interval, the MME node's unscheduled downtime estimation and based on the reliability of the IP layer connectivity. This value is configured higher, accounting for the loss of messages depending upon the reliability of IP layer connectivity

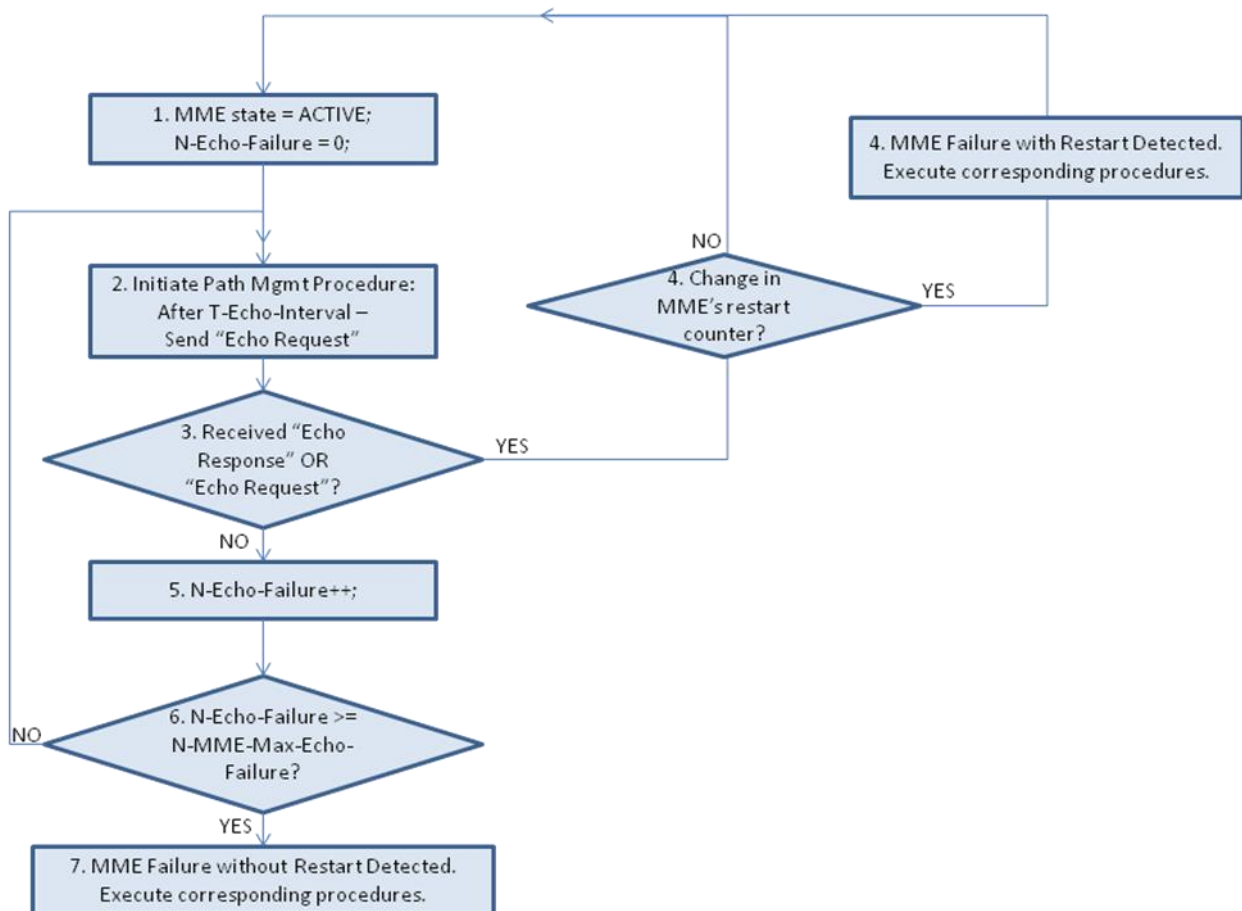

Figure 6.7.2.1-1: Using Path Management messages to detect MME failure without restart

- 1) MME is in healthy condition and capable of handling session management and path management procedures for the new and existing subscriber session. We term this as MME in "Active" state. N-Echo-Failure count is set to "0".
- 2) The SGW initiates path management procedures and sends "echo request" message to the MME S11 interface IP address, after configured time interval – "T-Echo-Interval". Please refer to section 20 of 3GPP TS 23.007 [2].
- 3) If the MME is "Active", it shall respond to the "echo request" by sending "echo response" message to the SGW.
- 4) If the "echo response" or "echo request" message is received from the MME, SGW compares the "restart counter" value as received in the message.

The change in the "restart counter" value signifies MME has failed and restarted. The corresponding procedure to handle "MME failure with restart" is executed by the SGW. Once completed, the procedure from step 1 is executed by the SGW.

If there is no change in the "restart counter" value, then the MME is in healthy condition and there is no MME failure. The procedure from step 1 is executed by the SGW.

- 5) If SGW does not receive any "echo response" or "echo request" message, the N-Echo-Failure count is incremented.
- 6) The N-Echo-Failure count value is compared with the N-MME-Max-Echo-Failure count value. If limit is not reached, the SGW executes procedure from step 2.
- 7) If the N-Echo-Failure count has exceeded the configured value of N-MME-Max-Echo-Failure count, the MME failure without restart is detected by the SGW.

6.8 EPC Node Restoration for Partial Failure of EPC nodes

6.8.0 Solutions for general enhancement to the Partial Failure when ISR is active

6.8.0.1 Solution 1 : Keep MME FQ-CSID in the PGW when UE is ISR activated

6.8.0.1.1 Description

The preconditions of this solution are:

- 1) The MME, the SGW and the PGW support Partial failure feature;
- 2) The SGW, the MME and the S4-SGSN support ISR feature, and ISR will be activated for the UEs.

The solution makes it possible that the MME can still retrieve the affected PDN connection indicated by PGW FQ-CSID included in Delete PDN Connection Set Request message sent from the SGW to the MME if the PGW FQ-CSID is not changed or has been updated in the MME when the PGW experiences a Partial failure.

The solution also makes it possible that the MME can still retrieve the affected PDN connection indicated by SGW FQ-CSID included in Delete PDN Connection Set Request message sent from the SGW to the MME if the SGW FQ-CSID is not changed or has been updated in the MME when the SGW experiences a Partial failure.

The solution consists in following enhancements:

1. During an inter MME to S4-SGSN RAU procedure, or an inter SGSN to MME TAU procedure, the ISR will be activated. When the SGW receives the Modify Bearer Request message where ISR is indicated to be activated, the SGW shall include the MME FQ-CSID and a new flag called RIPI (Restriction Indication for Partial failure when ISR active) in the Modify Bearer Request over S5/S8 to the PGW, where the RIPI flag indicates that some restrictions as below in the bullets c and d shall be applied for the PGW.
2. After RAU/TAU procedure and as long as the ISR is activated, the following apply:

- a. The SGW shall not change SGW FQ-CSID assigned before ISR activation if the undergoing procedure does not involve the MME and the PGW, because the MME and the PGW cannot update the SGW FQ-CSID.
 - b. The SGW shall include either the existing MME FQ-CSID or a new MME FQ-CSID in a message sent over S5/S8 when the SGW FQ-CSID is to be included; The SGW shall also include and set the RIPI flag in a message to the PGW as long as ISR is activated.
 - c. The PGW shall keep the MME FQ-CSID and the PGW shall not change PGW FQ-CSID assigned before receiving the first Modify Bearer Request message with the RIPI flag set until it receives a message without RIPI flag set.
 - d. When Delete PDN Connection Set request message including the stored MME FQ-CSID is received and if for the UE with RIPI flag set, the PGW shall only delete the stored MME FQ-CSID but not the associated PDN connection; for other UEs without RIPI flag set, the PGW delete the corresponding PDN connection as specified in 3GPP TS 23007 [2].
 - e. When the MME deactivates ISR, e.g. when SGSN restarts, the SGW shall send Modify Bearer Request message or Update PDN connection set request message when using Modify Bearer Request is not possible without setting the RIPI flag.
 - f. When the SGSN deactivates ISR, e.g. when MME restarts, the SGW shall send Modify Bearer Request message or Update PDN connection set request message when using Modify Bearer Request is not possible without setting the RIPI flag and MME FQ-CSID.
3. When the UE further moves to another SGSN, where the ISR will be deactivated, the SGW shall use Modify Bearer Request message or Update PDN Connection Set Request message when using Modify Bearer Request is not possible, without providing MME FQ-CSID and without setting the RIPI flag to remove the stored MME FQ-CSID in the PGW. When the UE further moves to another MME, where the ISR will be deactivated, the SGW shall use Modify Bearer Request message or Update PDN Connection Set Request message when using Modify Bearer Request is not possible, together with the new MME FQ-CSID to update the old MME FQ-CSID in the PGW, the RIPI flag shall not be set.

6.8.0.1.2 Evaluation

6.8.0.1.2.1 Pros

This subclause lists the pros of solution 1 - Keep MME FQ-CSID in the PGW when UE is ISR activated as following:

The advantage of using Partial failure will remain even when ISR is activated: The solution solves problem that when ISR is activated, unsynchronized FQ-CSID(s) leads Partial failure feature cannot be utilised, i.e. massive signalling over S11 and S5/S8 at EPC node partial failure.

6.8.0.1.2.2 Cons

This subclause lists the cons of solution 1 - Keep MME FQ-CSID in the PGW when UE is ISR activated as following:

The SGW and PGW cannot change the FQ-CSID assigned before ISR activation: In certain cases, the SGW and PGW cannot change the FQ-CSID assigned before ISR activation since the MME may not be able to update those changes.

6.8.1 Alternative Solutions for MME Partial Failure

6.8.1.1 Solution 1: S4-SGSN Clean up when SGW or MME does not support Network Triggered Restoration for MME partial failure

6.8.1.1.1 Description

This solution is to solve the case when the MME and/or SGW does not support Network Triggered Restoration procedure and SGW receives a Delete PDN Connection Set Request from MME containing FQ-CSID corresponding to partial failure.

6.8.1.1.1.1 Clean-up initiated by SGW procedure

When the MME or SGW does not support Network Triggered Restoration, the SGW upon receipt of Delete Connection Set Request from the MME:

- 1) Retrieves all the PDN connections corresponding to each of the MME FQ-CSID(s). The SGW shall send S5/S8 Delete PDN Connection Set Request (or PMIPv6 Binding Revocation Indication with the Gbit set) containing the FQ-CSID(s) received from the MME to PDN GW as described in 3GPP TS 23.007 [2].
- 2) Initiates Delete Bearer Request towards ISR associated S4-SGSN associated with the UE for all the retrieved PDN connections affected by the partial failure in MME. All the PDN connections for the UE would be deleted. When the UE initiates a Service Request/RAU procedure, the UE would be forced to reattach to the PDN connections.
- 3) SGW also locally deletes all the PDN connections as indicated by the MME FQ-CSID(s) and also forward the Delete PDN connection request to PDN GW.

6.8.1.1.2 Evaluation

6.8.1.1.2.1 Pros

This subclause lists the pros of solution 1:

Works with legacy S4-SGSNs: This solution does not expect any additional support for S4-SGSN;

6.8.1.1.2.2 Cons

This subclause lists the cons of solution 1:

May cause signalling overload on S4 interface: Since individual sessions have to be deleted from SGSN, the procedure can cause signalling overload on S4 interface.

Editor's Note: The interaction of MME partial failure and ISR may need further analysis. This may impact the solutions described below when ISR is enabled.

6.8.1.2 Solution 2 – Based on Network Triggered Service Restoration for complete MME failure w/o sending Delete PDN Connection Set Request to PGW

6.8.1.2.1 Description

The solution for network triggered service restoration is same as explained in Section 25 of 3GPP TS 23.007 [2] where the PDN connection which are associated with the FQ-CSID received in delete PDN connection set request which are eligible for network restoration. The SGW processes Delete Connection Set request received from the MME but does not relay it to the PDN GW.

The SGW starts a timer upon receipt of the Delete PDN Connection Set request. When this timer expires, the SGW locally deletes all the PDN connections affected by the MME partial Failure which were not restored. The SGW may additionally clean up the PDN GW context by sending Delete Session Requests for individual PDN connections.

NOTE: The timer in SGW is the same timer as explained in Clause 25 of 3GPP TS 23.007[2].

6.8.1.2.2 Evaluation

6.8.1.2.2.1 Pros

Works with pre-rel-11 MME and PGW: Since this procedure does not change the behavior in MME and PGW, this procedure will work with Rel-10 MME which supports Network Triggered Restoration and a Rel-8 PGW.;

EPS Service after MME Partial failure: This approach enables UEs to make the re-attach to the EPS possible triggered by an arrival of the downlink packet after the MME has partial failed

6.8.1.2.2.2 Cons

Hanging resources or signalling overload in the SGW and PGW: If SGW does not send Delete Session Requests for individual PDN connections, this mechanism causes hanging PDN connection in PDN GW. Else it may cause signalling overload in SGW and PGW.

Maintained resources in the SGW and PGW after MME Partial failure detection: This approach requires reservation of UE resource (S5/S8 bearer contexts) until downlink packets arrives for the UE or timer set in SGW expires. However comparing the network resources allocated for the affected UEs before and after the MME partial failure, the network (SGW and PGW) doesn't allocate any extra resource.

Delayed Deletion for PDN connection not eligible for restoration: If same CSID is used by the MME for the PDN connections which are eligible for restoration and those not eligible for restoration, the PDN connections not eligible for restoration will only get deleted after the SGW timer expires.

6.8.1.3 Solution 3 – Based on Network Triggered Service Restoration for complete MME failure with delayed sending of Delete PDN Connection Set Request to PGW

6.8.1.3.1 Description

The solution for network triggered service restoration is same as explained in Section 25 of 3GPP TS 23.007 [2] where the PDN connection which are associated with the FQ-CSID received in delete PDN connection set request which are eligible for network restoration. The SGW processes Delete Connection Set Request received from the MME but does not relay to the PDN GW.

The SGW starts a timer is started upon receipt of the Delete PDN Connection Set Request. When this timer expires, the SGW sends a delete PDN Connection Set Request along with the FQ-CSID received from the MME to PDN GW. The solution requires that the MME does not reallocate the same CSID to new PDN connections established after the MME partial failure before the SGW timer expiry. Once the PDN GW receives the Delete PDN Connection Set Request, all the PDN Connections related to the failed FQ-CSID are deleted.

The impacted UEs which performed a TAI or service request procedure before the timer expired, would have re-established the PDN connections (with new MME FQ-CSID(s)). The other UEs which perform RAU in SGSN area after the TAI timer in the UE expired would have ISR disabled.

The UE for which the TAU timer has expired starts implicit detach timer. Once the implicit detach timer expires while the UE is still in SGSN service area, the UE disables the ISR. When RAU timer expires for the ISR disabled UE, the SGSN sends Modify Bearer Request with ISRAI bit not set.

An SGW which receives a Modify Bearer request from the SGSN without ISRAI set, shall deregister the MME FQ-CSID which is registered for the UE by sending Modify Bearer Request message or Update PDN Connection Set Request. This clears the MME FQ-CSID in the PDN GW. Thus these UEs PDN connections will not get deleted when SGW forwards the Delete PDN Connection Set Request.

NOTE: The value of the timer in SGW may be equal to the periodic tracking area update timer (timer T3412) as specified in the 3GPP TS 24.301 [4]. There is one DLDTA timer in the SGW. When ISR has been enabled in the network, the value of the timer in SGW may be equal to twice the value of the periodic tracking area timer or periodic routing area timer (whichever is higher).

6.8.1.3.2 Evaluation

6.8.1.3.2.1 Pros

No Hanging PDN connection in PDN GW or Signalling overload: Since no individual session level signalling is done for cleaning up of resources, there are no hanging PDN connections or risk of signalling overload (once the timer in SGW expires).

EPS Service after MME Partial failure: This approach enables UEs to make the re-attach to the EPS possible triggered by an arrival of the downlink packet after the MME has partial failed

6.8.1.3.2.2 Cons

Maintained resources in the SGW and PGW after MME Partial failure detection: This approach requires reservation of UE resource (S5/S8 bearer contexts) until downlink packets arrives for the UE or timer set in SGW expires. However comparing the network resources allocated for the affected UEs before and after the MME partial failure, the network (SGW and PGW) doesn't allocate any extra resource.

Delayed Deletion for PDN connection not eligible for restoration: If same CSID is used by the MME for the PDN connections which are eligible for restoration and those not eligible for restoration, the PDN connections not eligible for restoration will only get deleted after the SGW timer expires.

6.8.2 Alternative Solutions for SGW Partial failure

6.8.2.1 Solution 1 : SGW relocation at the SGW Partial Failure

6.8.2.1.1 Description

The solution makes it is possible that the terminating service such as IMS voice could be delivered to the affected UE(s) even after SGW partial failure and the solution also enables those affected UE due to the SGW partial failure need not perform re-attach to the EPS to allow the service continuity. The MME, SGW and PGW can use the existing Partial Failure procedures to exchange the capability to support this solution and as well as related information to make sure that the solution works with the same logic.

NOTE 1: Inclusion of the related information is optional, where the PGW could indicate to the MME at the first time to contact, based what criteria e.g. the value of ARP, QCI and APN, the affected PDN connection should be maintained. By default, all affected PDN connection will be maintained.

Editor's Note: The interaction between MME and PGW to decide of which effected PDN connection are applicable to the solution need further study.

The solution consists in applying the Solution 1 for SGW failure by MME/S4-SGSN re-establishing resources with a new SGW or to the old SGW after its recovery as specified in the subclause 6.3.1 of the present document, and Solution 2 for SGW failure by PGW initiated paging request at receiving downlink data/signalling as specified in 6.3.2 of the present document, only to the PDN connections affected by the SGW partial failure, with the following differences:

- 1) The MME and PGW detect the SGW partial failure by receiving Delete PDN Connection Set Request message.
- 2) The PGW always include the MME identifier when sending the new Paging Request message.

6.8.2.1.2 Evaluation

6.8.2.1.2.1 Pros

This subclause lists the pros of solution 1 - SGW relocation at the SGW Partial Failure as following:

Re-establishments of resources in SGW transparent to the UE: The MME performs the SGW relocation signalling within the network nodes. In other nodes, unless PGW/PCRF changes any bearer or its properties, the SGW relocation signalling due to SGW partial failure does not require any signalling between the UE and the network.

The terminating services can be delivered to the idle UEs: The PGW triggered paging request upon receiving downlink data at the SGW partial failure makes sure the terminating services can be delivered to the idle UEs.

6.8.2.1.2.2 Cons

This subclause lists the cons of solution 1- SGW relocation at the SGW Partial Failure as following:

Maintained associated resources in the MME and PGW after SGW partial failure detection: The MME and PGW maintain resources (MM contexts and bearer contexts) for the affected UE(s) after SGW partial failure detection during the procedure of re-establishing resources with a SGW in comparison with the existing requirement that the affected PDN connections are deleted. However comparing the network resources allocated

for the affected UEs before and after the SGW partial failure, the network (PGW and MME) doesn't allocate any extra resource.

6.8.2.2 Solution 2 : SGW relocation at the SGW Partial Failure when ISR is active

6.8.2.2.1 Description

The solution makes it is possible that the terminating service such as IMS voice could be delivered to the affected UE(s) even after SGW partial failure and the UEs are ISR activated, and the solution also enables those affected UE due to the SGW partial failure need not perform re-attach to the EPS to allow the service continuity. The solution assumes both ISR and Partial failure feature are deployed and activated in the network. In the present solution, the SGW is required to not change SGW FQ-CSID assigned before ISR activation if the undergoing procedure need not to contact the MME, i.e. MME cannot updated the SGW FQ-CSID.

Editor's Note : Whether there are more preconditions for this solution is FFS.

The MME, SGW and PGW can use the existing Partial Failure procedures to exchange the capability to support this solution and as well as related information to make sure that the solution works with the same logic. In addition, the MME and S4-SGSN can use Context Transfer procedure or the procedure for the Notification of supported features between peer GTP-C entities, to exchange the capability to support this solution and as well as related information to make sure that the solution works with the same logic.

NOTE 1: Inclusion of the related information is optional, where at the first time to contact, the information that based on what criteria e.g. the value of ARP, QCI and APN, the affected PDN connection should be maintained can be exchanged. The receiver of such related information may not attempt to change such information. By default, all affected PDN connection will be maintained.

Editor's Note : The interaction between MME/S4-SGSN and PGW to decide of which effected PDN connection are applicable to the solution need further study.

The solution consists in applying the Solution 2 for SGW failure: Maintain the ISR state as specified in the subclause 6.5.3.2 of the present document, only to the PDN connections affected by the SGW partial failure, with the following differences:

- 1) The MME and PGW detect the SGW partial failure by receiving Delete PDN Connection Set Request message.
- 2) The MME informs the ISR associated node S4-SGSN about the SGW had a Partial failure and also if the solution should be carried out with per UE message, which is indicating the affected PDN connections.
- 3) The PGW always include the MME identifier (part of MME FQ-CSID) when sending the new Paging Request message.

6.8.2.2.2 Evaluation

6.8.2.2.2.1 Pros

This subclause lists the pros of solution 2 - SGW relocation at the SGW Partial Failure when ISR is active as following:

EPS Services can be delivered to those ISR activated UE: The solution solves problem that ISR state is unsynchronized between network and UE, and it makes sure that EPS Services can be delivered to those ISR activated UEs which have been relocated to a new SGW.

6.8.2.2.2.2 Cons

This subclause lists the cons of solution 2- SGW relocation at the SGW Partial Failure when ISR is active as following:

Extra Signalling introduced in the network: Extra signalling over S3 to request the ISR associated mobility management node to select the same SGW to maintain ISR activated for each affected UEs due to SGW Partial failure; Extra signalling over S3 to request the ISR associated mobility management node to remove UE context when UE has moved to another MME or S4-SGSN; Extra signalling over S3 to allow the MME inform the ISR associated node S4-SGSN about the SGW partial failure.

Some UEs are forced to reattach: Before the S4-SGSN gets notified about SGW had a Partial failure by the MME, and if the UE send any uplink NAS messages which leads S4-SGSN to contact the SGW, the UE will be forced to re-attach to the network, however services are still restored.

6.8.3 Alternative Solutions for PGW failure

6.8.3.1 Solution 1 for PGW partial failure

6.8.3.1.1 Description

When ISR is not active and the MME detects the PGW has a Partial failure by receiving Delete PDN Connection Set Request containing PGW FQ-CSID from the SGW, the MME should release corresponding the PDN connections. If the UE has multiple PDN connections, the MME may send the release cause "reactivation required" to the UE. If the UE has only one PDN connections, the MME may send the release cause "explicit detach with reattach required" to the UE.

6.8.3.1.2 Evaluation

6.8.3.1.2.1 Pros

This subclause lists the pros of solution 1 for PGW Partial failure as following:

Service recovery soon: The service will be recovered soon if the release cause "reactivation required" or "explicit detach with reattach required" is sent to UE.

6.8.3.1.2.2 Cons

This subclause lists the cons of solution 1 for PGW Partial failure as following:

Possible RAN overload: When the MME detects the PGW has a partial failure, the MME may perform cleanup external resources including at eNodeB and UE. This may cause RAN overload.

6.9 EPC Node Restoration for Partial Failure of EPC nodes when ISR is active

6.9.0 General

Solutions in this clause are on top of Solution 1 for Keeping MME FQ-CSID in the PGW when UE is ISR activated as described in section 6.8.0.1.

6.9.1 Alternative Solutions for MME Partial Failure

6.9.1.1 Solution1 : IMSI paging in E-UTRAN access and TMSI paging in other access

6.9.1.1.1 Description

The preconditions of this solution are 1) The MME, the SGW and the PGW support partial failure feature; 2) The SGW, the MME and the S4-SGSN support ISR feature, and ISR will be activated for the UEs; 3) The MME and the SGW support the network triggered service restoration procedure as explained in Section 25 of 3GPP TS 23.007 [2].

When partial failure happened in the MME, the MME sends the Delete PDN Connection Set Request message to the SGW, FQ-CSIDs are included to identify the impacted PDN Connections. When the SGW receives this message:

- 1) The SGW maintains the UE contexts:

After receiving the Delete PDN Connection Set request from the MME, the SGW does not relay it to the PDN GW. And instead of removing associated resources, the SGW maintains the UE contexts after the detection of partial failure in the MME.

When SGW starts maintaining the UE bearers, SGW starts a timer for corresponding MME, e.g. ISR deactivate timer. The timer value may be equal to or bit longer than the periodic tracking area update timer (timer T3412) as specified in 3GPP TS 24.301 [4]. If the timer expires, the ISR resources (i.e. MME control plane address and TEID) shall be locally deleted. When SGW receives the Create Session Request message for the UE, the SGW deletes all maintained resources for the UE and then proceeds with the Create Session Request message handling as specified in 3GPP TS 29.274 [3]. Upon receiving indication that ISR is deactivated in the UE from MME/S4-SGSN, the SGW shall stop the timer and delete any ISR resources for the UE.

- 2) The SGW notifies the SGSN about the partial failure:

The SGW sends new message(s) including the identity of the impacted Users to the S4-SGSN, this step can also be executed by the MME. S4-SGSN replies the notification message(s) and deactivates ISR for the users. This can be achieved by only one message including multiple users' identities, or one message per UE.

- 3) The S4-SGSN deactivates ISR in the GPRS Ready/PMM_CONNECTED UE:

The S4-SGSN should perform the P-TMSI Reallocation procedure with a new RAI as specified in 3GPP TS 23.060 [7] and the UE will initiate a RAU procedure during which ISR can be deactivated in the UE.

- 4) Downlink data packets or signalling arrives to the SGW for the UE in GPRS_STANDBY/PMM_IDLE state while the timer in the step1) is still running.

When the SGW receives a downlink user plane or control plane packet on a maintained S5/S8 bearer, the SGW shall initiate the network triggered service request procedure towards the SGSN as specified in 3GPP TS 23.401 [6] subclause 5.3.4.3. In addition, if the S5/S8 bearer is eligible for network initiated service restoration, the SGW shall also immediately send an enhanced Downlink Data Notification message including IMSI to the MME.

The S5/S8 bearers eligible for network initiated service restoration are determined by the SGW based on operator's policy e.g. based on the QCI and/or ARP and/or APN.

- 5) The MME pages the UE and forces the UE to re-attach to the network, and the normal S4-SGSN pages the UE in the RAI using the P-TMSI.

When UE camps in the MME related network, the paging procedure and UE behaviour upon receiving the paging message is as specified in the subclause 25 "network triggered service restoration procedure" of the 3GPP TS 23.007 [5].

When UE camps on the S4-SGSN related network, the UE behaviour upon receiving the paging message is as specified in subclause 4.7.9.1.1 of the 3GPP TS 24.008 [5] or subclause 8.1.4 of the 3GPP TS 23.060 [7].

- 6) If the UE initiates the RAU, ISR is deactivated during this procedure. If the Service Request procedure is initiated, the S4-SGSN should perform the P-TMSI Reallocation procedure with a new RAI as specified in 3GPP TS 23.060 [7] after the service request procedure and the UE will initiate a RAU procedure during which ISR can be deactivated in the UE.

6.9.0.1.2 Evaluation

6.9.0.1.2.1 Pros

This subclause lists the pros of solution 1 for MME partial failure when ISR is active as following:

No inter PLMN dependency: This approach does not require any support from the EPC node across PLMNs. The approach only requires support in the SGW and MME/SGSN.

UE can be paged even when UE camps in the MME service area: When the SGW detects the partial failure in the MME, and the UE is activated in SGSN/MME or in idle state, SGW shall maintain the associated bearer contexts including the ISR resource. When UE camps in the MME service area, if MT service is initiated, the IMSI paging will be performed in MME side, and the UE starts the reattach procedure.

Mobile Terminated Service: When the SGW receives the downlink packets on the maintained bearers which will trigger the paging, if UE activated in the SGSN side instead of the MME side, an S-TMSI paging or P-TMSI paging will be performed in the SGSN side to keep the service continuity.

ISR deactivation in the UE: When the UE camps in the MME service area, ISR can be deactivated by the re-attach procedure. When the UE camps in the SGSN service area, ISR can be deactivated by the initiated/triggered RAU procedure.

6.9.0.1.2.2 Cons

This subclause lists the cons of solution 1 for MME partial failure when ISR is active as following:

Resources maintained in the SGW and ISR associated SGSN after the MME partial failure detection: This approach requires reservation of UE resource in SGW and ISR associated SGSN, e.g. SGW maintains the restarted MME control plane address and TEID until the timer as specified in the step 1) in subclause 6.9.0.1.1 expires.

7 Conclusions and recommendations

7.1 MME restoration

7.1.1 Comparison of proposed solutions

Table 7.1.1-1 comparison of each solution proposed in subclause 6.1

	Solution 1 Down Link Data Triggered Attach (DLDTA)	Solution 2 reattachment with HSS interaction	Solution 3 Pro-active Paging based approach	Solution 4 using the MME self-stored paging information
Background	Reactive solution to reattach the UE when the first downlink data packet is received for the UE, by IMSI paging the UE over the last known TAI list maintained in SGW.	Reactive solution to reattach the UE when the first downlink data packet is received for the UE, by IMSI paging the UE over the entire MME area, after HSS interaction.	Proactive solution to reattach the UE after the MME failure is detected, by IMSI paging the UE over the last known location information maintained in SGW.	Reactive solution to reattach the UE when the first downlink data packet is received for the UE, by S-TMSI paging the UE over the last known TAI list maintained in non-volatile memory of MME.
Entity triggering the UE paging	SGW when it receives downlink data packet on a bearer with e.g. special value of QCI, APN (MME policy).	SGW when it receives downlink data packet on a specific bearer (MME or PCRF policy).	MME when SGW detects MME failure, for UEs marked as URCCR, e.g. based on subscription profile, QCI/ARP, operator's policy (MME policy).	SGW when it receives downlink data packet on a bearer with e.g. special value of QCI, APN (SGW policy).
EPC nodes impacted	MME SGW	MME SGW HSS	MME SGW	MME SGW
Existing EPC procedure impacted	Extra information TA list is required to pass for each UE in the session mobility procedures between SGW and MME. Intra MME intra SGW TAU may require S11 signalling.	None.	Extra information URCCR status and "DAIP" (MME implementation specific container for subsequent IMSI paging) are required to pass in the session mobility procedures between SGW and MME. Intra MME intra SGW TAU may require S11 signalling.	None.
Existing EPC procedure dependency	Node Features notification (NOTE2, NOTE3)	Node Features notification (NOTE3)	Node Features notification (NOTE2, NOTE3)	Node Features notification (NOTE3)
Existing EPC signalling impacted	Signalling for paging notification (depending on terminating traffic) between SGW	Signalling for paging notification (depending on terminating traffic) between SGW	Extra signalling for paging notification between SGW and MME when	Signalling for paging notification (depending on terminating traffic)

	and MME when the downlink data packet arrives after MME restarts as this is done per UE.	and MME when the downlink data packet arrives after MME restarts as this is done per UE.	the MME restart is detected. This is bulk notification message.	between SGW and MME when the downlink data packet arrives after MME restarts as this is done per UE.
--	--	--	---	--

new EPC signalling required	intra MME, intra SGW TAU may require S11 signalling	Enhanced Update Location Request including IMSI and Response are required to support for interaction between MME and HSS.	intra MME, intra SGW TAU may require S11 signalling	None.
Additional EPC resources required	SGW running extra timer to remove the hanging PDN connections if no downlink data packet is received. SGW keeping extra information TA list for each UE.	SGW running extra timer to remove the hanging PDN connections if no downlink data packet is received.	SGW keeping the extra information "DAIP" for specific UEs (as directed by MME).	SGW running extra timer to remove the hanging PDN connections if no downlink data packet is received. MME stores S-TMSI, TAI list, IMSI and possible other parameters in the MME non-volatile memories.
Restarted MME overload impacts	Depends on Terminating traffic	Depends on Terminating traffic	Since the proactive paging is done, the MME may need to IMSI page for all URRCR enabled UEs. That may cause MME overload.	Depends on Terminating traffic
RAN resources impacts	the IMSI paging in the latest TAI list can avoid paging in all TA served by the MME and save some radio resource	Paging in all TA served by the MME may cause heavy impacts for radio resource.	Since the proactive paging is done, the MME may need to IMSI page for all URRCR enabled UEs. That may impact heavy RAN resources the IMSI paging in the latest TAI list can avoid paging in all TA served by the MME and save some radio resource	Paging with S-TMSI, TAI list and IMSI can limit the scope of paging that means can save RAN resource.
Impacts on EPC services after MME restart/failure	The first call after restart will fail (IMS voice , CSFB) until the UE is reattached	The first call after restart will fail (IMS voice , CSFB) until the UE is reattached	MO and MT calls will fail until the UE is reattached	The first call after restart will fail (IMS voice , CSFB) until the UE is reattached
Roaming impacts	None	The HSS in the HPLMN is required to be enhanced for the inbound roaming UE.	None	None
Covering Scenario Failure with Restart/ Failure without Restart/	Failure with and without restart	Failure with and without restart	Failure with and without restart	Failure with and without restart

Failure with and without Restart				
Other merits		<p>No need to pass any extra information on S11 and stored in S-GW for preparation</p> <p>Double IMSI paging can be avoided if the UE has already reattached to another MME</p>		<p>No need to pass any extra information on S11 and stored in S-GW for preparation</p> <p>Paging with S-TMSI can avoid meaningless re-attach process e.g. caused by IMSI paging even after UE already attached to the different MME.</p>
Other drawbacks	<p>The PDN connection in SGW, PGW may remain hanging if the UE attaches to the network via different (than the original) MME, SGW and PGW until timer set on S-GW expired.</p>	<p>The PDN connection in SGW, PGW may remain hanging if the UE attaches to the network via different (than the original) MME, SGW and PGW until timer set on S-GW expired.</p> <p>Benefit of HSS interaction for avoiding double IMSI paging might be limited. Most of the case if UE already attach to the different MME, few down link packet comes to old network.</p>	<p>During the time when the MME is down, the UE may get attached to network via different MME, SGW and PGW. Some solution might be required to avoid paging for such UE when the MME restarts.</p> <p>Additional mechanism to pace the UE paging is required to avoid Core network and RAN resource impacts. Re-attach process includes impact for EPC nodes/IMS nodes/AS for all URCR enabled UEs are occurred.</p> <p>Once UE could not respond IMSI paging e.g. temporally unreachable, UE cannot receive services until periodic TAU if UE camps on the same TA before and after unreachable because IMSI paging should not be re-tried.</p>	
NOTE 1: MME does not generate extra signalling towards SGW if SGW does not support this restoration solution.				
NOTE 2: SGW does not maintain bearers after detecting MME restart if MME does not support this restoration solution.				

7.1.2 Conclusion

Through the preceding technical investigation within this technical report, it is concluded that certain serious misoperations can occur upon MME failure with the procedures currently specified in 3GPP, e.g. a subscriber may not be able to receive any IMS terminating call until other procedure (such as TAU) makes the UE reattach to the network.

It is recommended to standardize the following compromise solution to provide service resiliency after an MME failure with restart.

This compromise solution enables the UE to reattach to the EPS triggered by downlink data packets or signalling after the MME restarts. This solution includes the following steps:

- 1) The SGW maintains the IMSI and S5/S8 bearers after detection of an MME restart

If the SGW detects that the MME has restarted (i.e. SGW receives the incremented restart counter from the MME), instead of removing associated resources, the SGW marks and maintains the corresponding S5/S8 bearers configured to be maintained. This makes it possible for the SGW to receive downlink data packets or signalling from the PGW or PCRF in case of PMIP based S5/S8. Which S5/S8 bearers are to be maintained/marked in the SGW after an MME restart is based on the operator's policy.

When an SGW marks the S5/S8 bearers, the SGW shall start a timer. The timer value is based on the preconfiguration. The value may be equal to the periodic tracking area update timer (timer T3412) as specified in 3GPP TS 24.301 [4]. If the timer expires, the maintained resources shall be locally deleted.

If the SGW receives the Create Session Request message for the UE while the timer is running, the SGW shall delete all bearers for this UE and then proceeds with the Create Session Request message handling as specified in 3GPP TS 29.274 [3].

- 2) Downlink data packets or signalling arrives at the SGW while the timer in the step1) is still running.

If the SGW receives a downlink data packet or a control plane message on the marked bearer, the SGW shall send an enhanced Downlink Data Notification message including the IMSI to the associated MME. The SGW shall discard the received downlink data packet or reject the signalling message (received from the PGW or PCRF in case of PMIP based S5/S8) with an appropriate cause value.

- 3) The MME pages and forces the UE to re-attach to the network. The paging area and subscriber's identity i.e. IMSI or S-TMSI used during the paging procedure is implementation dependent. Upon receiving a page message with the IMSI, the UE starts the reattach procedure as specified in subclause 5.6.2.2.2 of 3GPP TS 24.301 [4]. Upon receiving a page message with the S-TMSI, the UE starts the Service Request procedure, this will be rejected by the MME which triggers the UE to reattach to the network as specified in subclause 5.6.2.2.1 of 3GPP TS 24.301 [4].

NOTE 1: Paging in the MME serving area will cause excessive use of radio resources. How to reduce the impact on the radio resources is implementation dependent. As an example, the MME can send the paging area in the Private Extension IE to the SGW in an existing S11 message. After MME restarts, the SGW can send the paging area in the Private Extension IE in the Downlink Data Notification message with the IMSI to the MME. Then the MME can page the UE in this paging area contained in the Private Extension IE. This may enable a reduction in the size of the paging area to be addressed. As another example, the MME may store and recover the IMSI, S-TMSI, TAI list, SGW/PGW FQDN and other necessary information in a proprietary way (e.g. in an internal non-volatile memory or in an external proprietary server, etc).

NOTE 2: If a UE re-attaches to another MME, whilst this MME has failed (out of service) and some DL user plane packet are still received on the old maintained S5/S8 bearers, paging the UE with the IMSI forces the UE (if in idle mode) to re-attach once more to the EPS.

It is further recommended that Stage 2 and Stage 3 work be specified within existing specifications as defined within Annex A.

7.2 SGSN Restoration

7.2.1 Conclusion

Through the preceding technical investigation within this technical report, it is concluded that certain serious misoperations can occur upon SGSN failure with the procedures currently specified in 3GPP, e.g. a subscriber may not be able to receive any IMS terminating call until other procedure (such as RAU) makes the UE reattach to the network.

It is recommended to adopt the solution included in chapter 7.1.2 for MME restoration with appropriate substitution of terminology as shown below for the SGSN failure:

- MME → S4-SGSN;
- tracking area update timer (timer T3412) as specified in 3GPP TS 24.301 [4] → routing area update timer (timer T3312) as specified in 3GPP TS 24.008 [5];
- S-TMSI → P-TMSI;
- TAI list → RAI;
- Upon receiving a page message with the IMSI, the UE starts the reattach procedure as specified in subclause 5.6.2.2.2 of 3GPP TS 24.301 [4]. → Upon receiving a page message with the IMSI, the UE starts the reattach procedure as specified in subclause 4.7.9.1.2 of the 3GPP TS 24.008[5].
- Upon receiving a page message with the S-TMSI, the UE starts the Service Request procedure, this will be rejected by the MME which triggers the UE to reattach to the network as specified in subclause 5.6.2.2.1 of 3GPP TS 24.301 [4]. → Upon receiving a page message with the P-TMSI, UE starts the service request procedure and subsequently attach procedure in case of Iu Mode as specified in subclause 4.7.9.1.1 and 4.7.13 of the 3GPP TS 24.008 [5] or send any LLC frame to response paging request and subsequently attach procedure in case of A/Gb mode as specified in subclause 8.1.4 of the 3GPP TS 23.060 [7].

It is further recommended that Stage 2 and Stage 3 work be specified within existing specifications as defined within Annex A.

7.3 SGW restoration

7.3.1 Comparison of proposed solutions for SGW failure

Table 7.3.1-1 comparison of each solution proposed in subclause 6.3

	Solution 1 : MME/S4-SGSN re-establishing resources with a new SGW or to the old SGW after its recovery	Solution 2 : PGW initiated paging request at receiving downlink data/signalling
Background	The MME/S4-SGSN selects a new SGW or a recovered SGW for the Idle UEs. The MME/S4-SGSN should prioritize the SGW relocation for those UEs that are engaged in a Service Request or other mobility procedures	Downlink data/signalling triggers the MME/S4-SGSN to page the UE. When the MME/S4-SGSN initiates the NAS message, the MME/S4-SGSN will select a new SGW or the recovered SGW.
EPC nodes impacted	MME/S4-SGSN, PGW	MME/S4-SGSN, SGW, PGW
Existing EPC procedure impacted	Context Response message in the inter SGSN/MME TAU/RAU procedure may be impacted Service Request procedure may be impacted Inter SGSN/MME handover procedure may be impacted	Same impact may be applied with solution 1
Existing EPC procedure dependency	None	None
Existing EPC signalling impacted	None	None
new EPC signalling required	None	Paging Request is sent from PGW to SGW. DDN message including IMSI with TEID 0 is sent on the S4/S11 interface.
Additional EPC resources required	The MME/S4-SGSN and PGW maintain the bearers and MM context after detection of SGW restart; MME/S4-SGSN stores the PGW's capability per PDN or per-UE	The MME/S4-SGSN and PGW maintain the bearers and MM context after detection of SGW restart; MME/S4-SGSN stores the PGW's capability per PDN or per-UE; The PGW selects a SGW based on the local configuration or DNS procedure. PGW may buffer the DL packets The PGW should avoid repeating the paging requests to SGW shortly after sending the paging request and receives additional DL packets.
RAN resources impacts	None	None
Impacts on EPC services after SGW restart/failure	The DL packets may be dropped if the PDN connection has not recovered.	None
Roaming impacts	The MME/S4-SGSN needs to know whether the PGW in the HPLMN supports the capability to maintain the old PDN connection after SGW failure	The MME/S4-SGSN needs to know whether the PGW in the HPLMN supports the capability to maintain the old PDN connection

	or restarts, vice versa;	after SGW failure or restarts, vice versa;
PMIP Impacted if PMIP based S5/S8 interface is used	None	New PMIP mobility options need be defined
Other merits	None	None
Other drawbacks	The MME/S4-SGSN may overload if there are too many UE impacted	The PGW may need some method to select alternative SGW if the SGW fails without restart.

7.3.2 Conclusion

Through the preceding technical investigation within this technical report, it is concluded that certain serious misoperations can occur upon SGW failure (with or without restart) with the procedures currently specified in 3GPP, e.g. a subscriber may not be able to receive any IMS terminating call until other procedures make the UE reattach to the network, which introduces extra signalling over radio network.

It is recommended to standardize the solution 1 on the SGW failure as specified in subclause 6.3.1 as the baseline solution and solution 2 as specified in subclause 6.3.2 as an optional add-on solution. It is further recommended that Stage 2 and Stage 3 work be specified within existing specifications as defined within Annex A.

7.4 PGW restoration

Through the preceding technical investigation within this technical report, it is concluded that certain serious misoperations can occur upon PGW failure with the procedures currently specified in 3GPP, e.g. a subscriber may not be able to receive any downlink data packets until other procedure (such as Service Request) makes the UE reattach to the network.

It is recommended to standardize the enhancements documented in subclause 6.4.1.1 and 6.4.2.1 to provide service resiliency after a PGW failure with or without restart.

This solution enables the UE to initiate the PDN Connection establishment or PDP Context Activation procedure with same APN.

It is further recommended that Stage 2 and Stage 3 work be specified within existing specifications as defined within Annex A.

7.5 EPC restoration when ISR is active

7.5.1 MME/SGSN restoration when ISR is active

7.5.1.1 Conclusion

Serious misoperations similar to those described in subclauses 7.1.2 and 7.2.1 can occur upon an MME or SGSN failure when ISR is active. It is therefore recommended to standardize the solution documented in subclause 6.5.2.1 to provide similar service resiliency after an MME or SGSN failure when ISR is active:

- the SGW maintains all S5/S8 bearers after detecting an MME/S4-SGSN restart;
- when receiving subsequent DL user plane packet or control plane signalling, the SGW initiates the network trigger service request procedure towards the CN node that did not fail (i.e. normal Downlink Data Notification message), and sends an enhanced Downlink Data Notification message with IMSI to the node that restarted;
- the restarted node forces the UE to re-attach to the EPC; the node that did not fail performs a normal paging procedure.

The restoration procedure assumes that the MMEs and SGSNs homogeneously support network triggered service restoration with ISR. Scenarios with heterogeneous support of that feature (e.g. MME, SGSN and SGW support ISR, but only MME and SGW support network triggered service restoration) are for further study.

It is further recommended that Stage 2 and Stage 3 work be specified within existing specifications as defined within Annex A.

7.5.2 SGW Restoration procedure if ISR is activated

7.5.2.1 Comparison of proposed solutions for SGW failure if ISR is activated

Table 7.5.2.1-1 comparison of each solution proposed in subclause 6.5.3

	Solution 1 : Deactivate ISR state	Solution 2: Maintain ISR state	Solution 3:	Solution 4:
Background	In this solution, the ISR will be deactivated in the TAU/RAU procedure which was triggered by the P-TMSI/GUTI Reallocation procedure	The ISR can be maintained by sending an alternative SGW information to the associated MME/S4-SGSN.	In this solution, the ISR will be deactivated in the TAU/RAU procedure which was triggered by the P-TMSI/GUTI Reallocation procedure for the connected UE.	In this solution, the Configured Node initiates the SGW restoration. If UE initiates service request in non-configured node, the UE is forced to re-attach.
EPC nodes impacted	MME/S4-SGSN, PGW	MME/S4-SGSN, SGW, PGW	MME/S4-SGSN, SGW, PGW	MME/S4-SGSN, PGW
Existing EPC procedure impacted	None	None	None	None
Existing EPC procedure dependency	None	None	None	None
Existing EPC signalling impacted	None	None	None	None
new EPC signalling required	None	The S3 message that carries SGW FQDN and F-TEID information as well as its response message is needed	None	The S3 message that carries SGW FQDN and F-TEID information as well as its response message is needed.
Additional EPC resources required	None	None	None	Additional PDN resources due to hanging PDN connections.
RAN resources impacts	Possible RAN Overload	None	None	None
Impacts on EPC services after SGW restart/failure	None	None	None	None
Roaming impacts	PGW need maintain the UE context after SGW restart/failure	PGW need maintain the UE context after SGW restart/failure	PGW need maintain the UE context after SGW restart/failure	PGW need maintain the UE context after SGW restart/failure
Other merits	None	None	None	None
Other drawbacks	There may be some hanging PDN connections in the associated MME/SGSN.	None	None	Those ISR enabled UEs which perform Service Request and TAU/RAU in non-configured node between the time of SGW failure and SGW restoration may have to reattach

7.5.2.2 Conclusion

Through the preceding technical investigation within this technical report, it is concluded that certain serious misoperations similar to those described in subclause 7.3.2 can occur upon an SGW failure (with or without restart) when ISR is active.

It is recommended to standardize the solutions documented in subclause 6.5.3.1 and subclause 6.5.3.3 to provide similar service resiliency after a SGW failure when ISR is active.

It is further recommended that Stage 2 and Stage 3 work be specified within existing specifications as defined within Annex A.

7.6 Restoration of CS services after MME failure

7.6.1 Conclusion

Through the preceding technical investigation within this technical report, it is concluded that certain serious misoperations can occur upon MME failure with the procedures currently specified in 3GPP, e.g. a subscriber may not be able to receive any CS terminating call until other procedure (such as periodic TAU) makes the UE reattach to the network.

It is recommended to standardize the solution documented in subclause 6.6.2.1 to provide service resiliency after an MME failure without restart or a long MME failure.

This solution enables the network to continue delivering mobile terminated CS services to UEs via an alternative MME in the MME pool where the UE is located when the MME to which the UE was registered fails without restart or fails for a long duration.

It is further recommended that Stage 2 and Stage 3 work be specified within existing specifications as defined within Annex A.

Annex A (informative): Impacts to Specifications

Table A.1 identifies the existing specifications within CT Working Groups that require modification to define the MME/S4-SGSN Node Restoration procedure recommended by this feasibility study.

Table A.1 Impacts for MME/S4-SGSN restoration with or w/o ISR

Existing Specification	Responsible WG	Brief summary of impacts
3GPP TS 23.007	CT4	<p>Without ISR: The steps 1, 2 and 3 in the subclause 7.1.2 will be specified. The possible examples in the NOTE1 to reduce the impact on the radio resources will NOT be specified in TS 23.007</p> <p>With ISR: The principles described in subclause 6.5.2.1.1 will be specified.</p>
3GPP TS 29.274	CT4	<p>A supported feature is defined for the Downlink Data Notification with TEID "0" Extension to TEID "0" Downlink Data Notification message to contain the IMSI.</p> <p>With ISR: The Modify Bearer Request message shall be sent as part of the network triggered service restoration procedure with ISR during an intra MME TAU and an intra S4-SGSN RAU procedure for UEs that had ISR active before either the MME or the S4-SGSN has restarted. The Serving Network and Rat Type IEs are sent within the Modify Bearer Request message during the TAU/RAU without MME/S4-SGSN and SGW change.</p>

No new specifications are required.

Table A.2 identifies the existing specifications within CT Working Groups that require modification to define the SGW Restoration procedure recommended by this feasibility study.

Table A.2 Impacts for SGW restoration with or without ISR

Existing Specification	Responsible WG	Brief summary of impacts
3GPP TS 23.007	CT4	Without ISR: Define the stage 2 requirements along with the conclusion documented in subclause 7.3.2 With ISR: Define the stage 2 requirements along with the conclusion documented in subclause 7.5.2.2.
3GPP TS 29.274	CT4	Solution 1: The CSR and MBR message shall be sent as part of the MME/S4-SGSN triggered SGW restoration procedure. The Context Response message does not include SGW F-TEID IEs if the SGW has failed and SGW relocation is to be done by the new MME/S4-SGSN. Solution 2: New PGW Downlink Triggering Notification/ACK messages are specified over the S4/S11 and S5 interface and shall be sent as part of the PGW triggered SGW restoration procedure. The MME/S4-SGSN id is included in the existing signalling if the solution 2 is supported. With ISR: The new message on S3 interface is sent as part of the SGW failure with ISR.
3GPP TS 29.275	CT4	Solution 2: The MME/S4-SGSN id is included in the existing signalling if the solution 2 is supported. The enhanced PMIP message shall be sent as part of the PGW triggered SGW restoration procedure.

No new specifications are required.

Table A.3 identifies the existing specifications within CT Working Groups that require modification to define the PGW Restoration procedure recommended by this feasibility study.

Table A.3 Impacts for PGW restoration

Existing Specification	Responsible WG	Brief summary of impacts
3GPP TS 23.007	CT4	Define the stage 2 enhancement along with the principle documented in subclause 6.4.1.1 and 6.4.2.1.
3GPP TS 29.274	CT4	Extend the PGW Restart Notification message with a new Cause IE allowing the SGW to notify the MME/S4-SGSN that the peer PGW has failed and not restarted.

No new specifications are required.

Table A.4 identifies the existing specifications within CT Working Groups that require modification to define the procedure to restore CS services after an MME failure recommended by this feasibility study.

Table A.4 Impacts for Restoration of CS services after an MME failure

Existing Specification	Responsible WG	Brief summary of impacts
3GPP TS 23.007	CT4	Define stage 2 requirements along the principles documented in subclause 6.6.2.1.
3GPP TS 29.118	CT1	Define stage 3 requirements along the principles documented in subclause 6.6.2.1.
3GPP TS 23.018	CT4	The VLR may signal MTRF support in the MAP Update Location request it signals to the HLR upon the establishment of the SGs association.

No new specifications are required.

Annex B: Change history

Change history							
Date	TSG #	TSG Doc.	CR	Rev	Subject/Comment	Old	New
2012-12	CT#58	CP-120760			Presented for approval in CT#58	2.0.0	11.0.0