

3GPP TR 23.854 V11.0.0 (2011-06)

Technical Report

3rd Generation Partnership Project; Technical Specification Group Services and System Aspects; Enhancements for Multimedia Priority Service (MPS) (Release 11)



The present document has been developed within the 3rd Generation Partnership Project (3GPP™) and may be further elaborated for the purposes of 3GPP. The present document has not been subject to any approval process by the 3GPP Organizational Partners and shall not be implemented. This Specification is provided for future development work within 3GPP only. The Organizational Partners accept no liability for any use of this Specification. Specifications and reports for implementation of the 3GPP™ system should be obtained via the 3GPP Organizational Partners' Publications Offices.

Keywords

3GPP, Multimedia, Priority, Service

3GPP

Postal address

3GPP support office address

650 Route des Lucioles - Sophia Antipolis
Valbonne - FRANCE
Tel.: +33 4 92 94 42 00 Fax: +33 4 93 65 47 16

Internet

<http://www.3gpp.org>

Copyright Notification

No part may be reproduced except as authorized by written permission.
The copyright and the foregoing restriction extend to reproduction in all media.

© 2011, 3GPP Organizational Partners (ARIB, ATIS, CCSA, ETSI, TTA, TTC).
All rights reserved.

UMTS™ is a Trade Mark of ETSI registered for the benefit of its members
3GPP™ is a Trade Mark of ETSI registered for the benefit of its Members and of the 3GPP Organizational Partners
LTE™ is a Trade Mark of ETSI currently being registered for the benefit of its Members and of the 3GPP Organizational Partners
GSM® and the GSM logo are registered and owned by the GSM Association

Contents

Foreword	5
1 Scope	6
2 References.....	6
3 Definitions and abbreviations	7
3.1 Definitions	7
3.2 Abbreviations	8
4 Priority service scenarios	8
4.1 IMS Multimedia Priority Service	8
4.2 Priority EPS Bearer Service	8
4.3 CS Fallback	9
4.3.1 CS Fallback to GERAN/UTRAN.....	9
4.3.2 CS Fallback to 1xRTT.....	9
5 Architectural requirements	9
5.1 General Architecture principles for Multimedia Priority Services	9
5.1.1 MPS High Level Principles	9
5.1.2 MPS Bearer Management Principles	10
5.2 IMS Multimedia Priority Services.....	10
5.2.1 General.....	10
5.3 Priority EPS Bearer Service.....	10
5.4 CS Fallback	11
5.4.1 CS Fallback to GERAN/UTRAN.....	11
5.4.1.1 Mobile-terminated GERAN/UTRAN CS Fallback call for a user in E-UTRAN.....	11
5.4.1.2 Mobile-originated GERAN/UTRAN CS Fallback call by a Service User	11
5.4.2 CS Fallback to 1xRTT	11
5.4.2.1 Mobile-terminated 1xCSFB call originated by service-user in 1xRTT.....	11
5.4.2.2 Mobile-originated 1xCSFB call by a service-user	11
5.5 SRVCC.....	12
6 Key Issues for MPS.....	12
6.1 IMS Multimedia Priority Services.....	12
6.1.1 Key Issue 1 - Mobile Originated MPS Voice Session.....	12
6.1.1.1 Description	12
6.1.1.2 Solution.....	12
6.1.1.3 Impacted entities in the System.....	14
6.1.2 Key issue 2 - QoS handling for IMS multimedia priority Service	14
6.1.2.1 Description	14
6.1.2.2 Solution.....	14
6.1.2.3 Impacted entities in the System.....	15
6.1.3 Key issue 3 - Mobile-terminating IMS multimedia service to a user in E-UTRAN	15
6.1.3.1 Description	15
6.1.3.2 Solution.....	15
6.1.3.2.1 Terminating MPS session to users when the existing ARP of the default bearer and IMS signalling bearer is not consistent with MPS use	15
6.1.3.2.2 Terminating MPS session to users when the existing ARP of the default bearer and IMS signalling bearer is already consistent with MPS use.....	17
6.1.4 Key Issue 4 - Priority information download procedure	19
6.1.4.1 Description	19
6.1.4.2 Solution.....	19
6.1.5 Key Issue 5 – Priority resource handling in SRVCC	21
6.1.5.1 Description	21
6.1.5.2 Solution.....	22
6.2 Priority EPS Bearer Service	23
6.2.1 Key issue 1 - QoS of Default Bearer Assignment for an Always-On MPS Subscription	23
6.2.1.1 Description	23

6.2.1.2	Solution.....	23
6.2.2	Key issue2 - Priority Invocation/Revocation	25
6.2.2.1	Description	25
6.2.2.2	Solution.....	25
6.2.2.2.1	Solution 1: Upgrading/Downgrading priority (MPS) for Invoke/Revoke of On demand MPS	25
6.2.2.2.2	Solution-2: Always On MPS Activation.....	25
6.2.2.3	Impacted entities in the System.....	26
6.2.2.3.1	Solution-1: Upgrading/Downgrading priority (MPS) for Invoke/Revoke of On demand MPS	26
6.2.2.3.2	Solution-2: Always On MPS Activation.....	26
6.3	CS Fallback	27
6.3.1	CS Fallback to GERAN/UTRAN.....	27
6.3.1.1	Key Issue1 - Priority handling of mobile terminating call	27
6.3.1.1.1	Description	27
6.3.1.1.2	Solution.....	27
6.3.1.1.3	Impacted functions in the System.....	30
6.3.1.2	Key Issue2 - Priority radio resource handling in CS fallback	31
6.3.1.2.1	Description	31
6.3.1.2.2	Solution.....	31
6.3.1.2.3	Impacted functions in the System.....	33
6.3.1.3	Key Issue 3 - Priority handling of mobile originating call	33
6.3.1.3.1	Description	33
6.3.1.3.2	Solution.....	33
6.3.1.3.3	Impacted functions in the System	35
6.3.2	CS Fallback to 1xRTT	35
6.3.2.1	Key Issue1 - Procedure Flow for Priority handling of mobile terminating call.....	35
6.3.2.1.1	Description	35
6.3.2.1.2	Solution.....	36
6.3.2.1.3	Impacted functions in the System.....	37
6.3.2.2	Key Issue 2 – Procedure flow for Priority handling of mobile originated call	37
6.3.2.2.1	Description	37
6.3.2.2.2	Solution.....	37
6.3.2.3	Impacted functions in the System.....	39
7	Overall Solution	39
7.1	IMS Multimedia Priority Services	39
7.2	Priority EPS Bearer Service	39
7.3	CS Fallback	39
8	Conclusions	39
Annex A:	Change history	41

Foreword

This Technical Report has been produced by the 3rd Generation Partnership Project (3GPP).

The contents of the present document are subject to continuing work within the TSG and may change following formal TSG approval. Should the TSG modify the contents of the present document, it will be re-released by the TSG with an identifying change of release date and an increase in version number as follows:

Version x.y.z

where:

- x the first digit:
 - 1 presented to TSG for information;
 - 2 presented to TSG for approval;
 - 3 or greater indicates TSG approved document under change control.
- y the second digit is incremented for all changes of substance, i.e. technical enhancements, corrections, updates, etc.
- z the third digit is incremented when editorial only changes have been incorporated in the document.

1 Scope

MPS will enable National Security/Emergency Preparedness (NS/EP) users (herein called Service Users) to make priority calls/sessions using the public networks. This service needs to be ensured also under special conditions such as network congestion. Service Users are the government-authorized personnel, emergency management officials and/or other authorized users. Effective disaster response and management rely on the Service User's ability to communicate during congestion conditions. Service Users are expected to receive priority treatment, in support of mission critical multimedia communications.

The enhancements for MPS evaluated in this document are priority aspects of EPS packet bearer services and priority related interworking between IMS and EPS packet bearer services. These enhancements enable the network to support end-to-end priority treatment for MPS call/session origination/termination, including the Non Access Stratum (NAS) and Access Stratum (AS) signalling establishment procedures at originating/terminating network side as well as resource allocation in the core and radio networks for bearers. Priority treatment will be applicable to IMS based multimedia services, priority EPS bearer services and CS Fallback.

This document clarifies the architectural requirements for MPS, considers the priority service scenarios, and evaluates solution alternatives. Solutions will be proposed and evaluated based on the following three service categories: IMS based multimedia service (voice, video etc), priority EPS bearer services (PS data without IMS interaction) and CS Fallback. Common issues for multiple service categories should be resolved by single solution to limit the amount of overall functionality and to avoid complexity.

The basic eMPS, i.e. priority handling of IMS based multimedia service, EPS bearer services and CS Fallback have completed in Rel-10. In Rel-11, Single Radio Voice Call Continuity (SRVCC) from LTE to UTRAN/GERAN/1xCS will be investigated based on Rel-10 SRVCC specification.

The result of the analysis should be suitable as a basis for normative MPS specification work.

The scope of the MPS part is to further investigate:

- The signalling and procedures for identifying priority and authorizing the usage of priority service.
- The required priority attributes used in enabling end-to-end priority marking and priority treatment during establishment, modification and release of an IMS based priority voice/video/data session.
- The scenarios and capabilities for supporting priority EPS bearer data services.
- The potential impacts on existing and relevant standard procedures in order to provide preferential treatment for MPS requests in the event of congestion.
- Inter-working with other IMS and CS networks to provide an end-to-end priority service.

2 References

The following documents contain provisions which, through reference in this text, constitute provisions of the present document.

- References are either specific (identified by date of publication, edition number, version number, etc.) or non-specific.
- For a specific reference, subsequent revisions do not apply.
- For a non-specific reference, the latest version applies. In the case of a reference to a 3GPP document (including a GSM document), a non-specific reference implicitly refers to the latest version of that document *in the same Release as the present document*.

[1] 3GPP TR 21.905: "Vocabulary for 3GPP Specifications".

[2] 3GPP TS 22.153: "Multimedia priority service".

- [3] 3GPP TS 23.401: "General Packet Radio Service (GPRS) enhancements for Evolved Universal Terrestrial Radio Access Network (E-UTRAN) access".
- [4] 3GPP TS 23.002: "Network architecture".
- [5] 3GPP TS 25.413 [5]: "UTRAN Iu interface Radio Access Network Application Part (RANAP) signalling".
- [6] 3GPP TS 23.272: "Circuit Switched (CS) fallback in Evolved Packet System (EPS); Stage 2".
- [7] 3GPP TS 36.331: "Evolved Universal Terrestrial Radio Access (E-UTRA); Radio Resource Control (RRC); Protocol specification".
- [8] 3GPP TS 22.011: "Service accessibility".
- [9] 3GPP2 A.S0008-C: "Interoperability Specification (IOS) for High Rate Packet Data (HRPD) Radio Access Network Interfaces with Session Control in the Access Network".
- [10] 3GPP2 A.S0009-C: "Interoperability Specification (IOS) for High Rate Packet Data (HRPD) Radio Access Network Interfaces with Session Control in the Packet Control Function".
- [11] 3GPP TS 24.301: "Non-Access-Stratum (NAS) protocol for Evolved Packet System (EPS); Stage 3".
- [12] 3GPP TS 23.228: "IP Multimedia Subsystem (IMS); Stage 2".
- [13] 3GPP TS 24.229: "IP multimedia call control protocol based on Session Initiation Protocol (SIP) and Session Description Protocol (SDP); Stage 3".
- [14] 3GPP TS 29.228: "IP Multimedia (IM) Subsystem Cx and Dx Interfaces; Signalling flows and message contents".
- [15] 3GPP TS 23.203: "Policy and charging control architecture".
- [16] 3GPP TS 23.216: "Single Radio Voice Call Continuity (SRVCC)".
- [17] 3GPP TS 23.009: "Handover procedures".
- [18] 3GPP TS 48.008: "Mobile Switching Centre - Base Station System (MSC-BSS) interface; Layer 3 specification".
- [19] 3GPP TS 23.237: "IP Multimedia Subsystem (IMS) Service Continuity; Stage 2".
- [20] 3GPP TS 23.221: "Architectural requirements".

3 Definitions and abbreviations

3.1 Definitions

For the purposes of the present document, the terms and definitions given in TR 21.905 [1] and the following apply. A term defined in the present document takes precedence over the definition of the same term, if any, in TR 21.905 [1].

MPS: Based on TS 22.153 [2]. Multimedia Priority Service allows authorized users to obtain and maintain radio and network resources with priority, also during situations when PLMN congestion is blocking session establishment attempts.

MPS session: A session (e.g., voice, video, data session) for which priority treatment is applied for allocating and maintaining radio and network resources.

MPS subscription: A subscription by which priority services are provided, if the network supports MPS. MPS subscription entitles a USIM with special Access Class(es). MPS subscription profile is stored in the operator's network.

MPS-subscribed UE: A UE having a USIM with MPS subscription.

Service User: As per TS 22.153 [2].

On-demand MPS: Priority treatment is explicitly requested by a Service User. Priority treatment is granted by the network and can be revoked by the Service User or network. An example of the On-demand mechanism is the use of specific access code provided by the Service User when activating a session to request priority treatment.

Always-on MPS subscription: A type of MPS subscription where priority treatment is provided for all PS sessions for the Service User.

3.2 Abbreviations

For the purposes of the present document, the abbreviations given in TR 21.905 [1] apply.

4 Priority service scenarios

Editor's Note: This clause will list the service scenarios for which priority handling is applied.

4.1 IMS Multimedia Priority Service

An example of an IMS-based MPS session is a voice call established using IMS procedures. The MPS voice session described by the following use cases shall be handled in a prioritized way.

- Mobile origination from an MPS-subscribed UE by including an MPS code/identifier: A Service User originates an IMS-based MPS session by including an MPS code/identifier followed by a destination address (e.g., SIP URI, Tel URI) from an MPS-subscribed UE attached to E-UTRAN. In this scenario, based on the EPS subscription information and operator's policy, priority treatment for the default bearer and the EPS bearer carrying SIP/IMS signalling may be given in the EPS prior to and during IMS-based MPS invocation. Priority treatment in the EPS for signalling and media bearers may be modified/established via PCC based on the session authorization information received from the AF.
- Mobile origination from any UE by including an MPS input string: A Service User invokes an IMS-based MPS session by including an MPS input string from any UE (MPS subscribed or not) attached to E-UTRAN. Following an IMS-based MPS identification and authorization, priority indication and priority treatment are provided to the session in the EPS via PCC. In this scenario, the UE may also receive priority for signalling and media for collection of additional credentials from the Service User.
- Mobile termination: A Service User initiates an MPS session to a terminating user (either a Service User or a normal user) in E-UTRAN. The terminating network identifies the priority of the session and applies priority treatment to ensure that the call is delivered with priority.
- SRVCC of IMS based priority call: When the UE has on-going IMS based priority call and the eNB initiates SRVCC procedure, network resources for voice bearer in the PS, CS and IMS networks of the target system should be reserved in prioritized manner.

NOTE 1: For Mobile Origination from any UE, the UE should be able to originate a session (e.g., for prepaid UEs, there is available credit).

NOTE 2: For a Mobile Terminating IMS session from a normal user to a Service User, no priority treatment for the media is required. However, based on operator's policy and subscription information, EPS signalling may still be treated with priority on the terminating side.

NOTE 3: No analysis has been done for IMS-based MPS session for video and voice/video.

4.2 Priority EPS Bearer Service

Editor's Note: This clause will describe the MPS scenarios for setting up priority EPS bearers when IMS is not used.

On-demand MPS is activated/deactivated via an AF (e.g., HTTPS server) interaction: The connected Service User interacts with an AF to activate/authorize invocation of priority bearer service. The AF communicates the priority

authorization to the PCC infrastructure. Priority is deactivated when the Service User explicitly revokes the priority bearer service via the AF, the AF revokes the priority bearer service or when the PDN connection is released.

For a third-party AF, the invocation/revocation of the On-demand EPS priority treatment may be performed, but outside of the scope of this work.

Always-on MPS receives priority bearer service (e.g. ARP and QCI) for all bearers.

4.3 CS Fallback

4.3.1 CS Fallback to GERAN/UTRAN

In the following CS Fallback use case, the CS Fallback related procedures shall be handled in the following way.

- **Mobile-terminating call to a user in E-UTRAN:** A Service User initiates a voice call to the terminating user (either a Service User or normal user) in E-UTRAN access and terminating MSC forwards the paging request to the MME. The MME initiates the CS Fallback procedure with priority so that the terminating user can receive the mobile terminating call in the GERAN/UTRAN CS domain.
- **Mobile-originating call by a MPS-subscribed UE in E-UTRAN:** A Service User initiates a voice call in E-UTRAN using procedure for CS fallback to GERAN/UTRAN with priority indication.

NOTE 1: A mobile-originating call made by non-MPS-subscribed UE dialling MPS input string (dialling number) is treated as normal CSFB call.

NOTE 2: For a Mobile Terminating Call from a normal user to a service user, no special handling is required.

4.3.2 CS Fallback to 1xRTT

The following two MPS scenarios are supported:

- **Mobile-terminating call to a user in E-UTRAN:** A Service User initiates an 1xCS voice call to the terminating user (either a Service User or normal user) in E-UTRAN access and the IWS forwards the paging request to the MME with a priority indication. The MME initiates the CS Fallback procedure with a priority indication in order to transfer the terminating user to the 1x RTT network.
- **Mobile-originating call by a Service User in E-UTRAN:** A Service User initiates a voice call in E-UTRAN using procedure for CS fallback to 1xRTT with a priority indication.

NOTE: For a Mobile Terminating Call from a normal user to a service user, no special handling is required.

5 Architectural requirements

Editor's Note: This clause will identify the architectural requirement for scenarios described in clause 4.

5.1 General Architecture principles for Multimedia Priority Services

5.1.1 MPS High Level Principles

The MPS Solution(s) shall be based on the following principles:

- MPS shall be based on existing 3GPP architecture TS 23.002 [4].
- MPS shall be based on the existing QoS mechanisms as specified in E-UTRAN and EPC specifications, e.g. TS 23.401 [3].

- MPS supports priority sessions on an "end-to-end" priority basis. Note that if a session terminates on a server in the Internet (e.g. web-based service), then the remote end and the Internet transport are out of scope.
- MPS is based on the ability to invoke, modify, maintain and release sessions with priority and deliver the priority media packets under network congestion conditions.
- A user shall be subscribed and authorized for MPS. Such user is referred to as a Service User as per TS 22.153 [2].
- The solution(s) shall support an on-demand MPS session that is based on Service User invocation.
- MPS is applicable to IMS session based services (voice, video and data) as well as EPS bearer data services. Pre-emption of non-Service Users is subject to national/regional regulations.
- MPS shall be supported in a roaming environment when roaming agreements are in place and where regulatory requirements apply.
- An MPS-subscribed UE shall belong to one of the 5 special access-classes (Access Classes 11 to 15) as defined in TS 22.011 [8]
- Network uses existing Access Class Barring mechanism per TS 36.331 [7] and TS 22.011 [8] to provide preferential access to MPS subscribers compared to ordinary users, and to avoid overload situations.

5.1.2 MPS Bearer Management Principles

When an MPS session is requested by a Service User, the following bearer management principles shall apply:

- EPS bearers employed in an MPS session shall be assigned ARP value settings corresponding to the priority level of the Service User.
- ARP pre-emption capability and vulnerability settings for eMPS bearers are subject to operator policies and depending on national/regional regulatory requirements.

5.2 IMS Multimedia Priority Services

5.2.1 General

- For IMS-based Multimedia Services, MPS shall support mechanisms to establish AS and NAS connections with priority.
- An MPS subscribed UE shall be assigned special Access Class(es), within the range 11-15, to gain prioritized access to the E-UTRAN during congestion.
- Based on regional regulatory requirements, an MPS subscribed UE may optionally establish an EPS default bearer and a dedicated bearer that is used to transport IMS/SIP signalling with priority. During the time of initial attach/PDN connection, based on the priority indication received from the SPR for the user, the PCRF determines whether to establish the default EPS bearer and a dedicated bearer that handles IMS/SIP signalling with priority.
- PCC shall be deployed in a network supporting MPS IMS priority services. Subscription information in SPR for Service User shall reflect the user's priority level as defined in TS 22.153 [2] and enable the PCRF to determine the appropriate ARP setting for PCC rules when IMS priority service is invoked.

5.3 Priority EPS Bearer Service

Editor's Note: This clause will describes the architecture requirement for priority handling of EPS bearer when IMS is not used as service layer.

The Priority EPS bearer services solution(s) shall be based on the following principles:

- On-demand priority EPS Bearer Service invocation is performed via network initiated resource allocation procedure and does not use UE initiated bearer resource allocation procedure.

- PCC shall be deployed in a network supporting MPS Priority Bearer service. Subscription information in SPR for Service User shall reflect the user's priority level as defined in TS 22.153 [2] and enable the PCRF to determine the appropriate ARP setting for PCC rules when MPS bearer service is invoked.

5.4 CS Fallback

5.4.1 CS Fallback to GERAN/UTRAN

For CS Fallback to GERAN/UTRAN, MPS shall support a mechanism to properly handle the priority voice call and enable the terminating user and/or call originating Service User to establish the AS and NAS connection to fallback to the GERAN/UTRAN

Followings are the architectural requirements to achieve priority handling of GERAN/UTRAN CS Fallback MPS scenarios.

5.4.1.1 Mobile-terminated GERAN/UTRAN CS Fallback call for a user in E-UTRAN

- If MME receives paging request with priority from MSC, the MME shall preferentially handle paging request to initiate CS Fallback procedure compared to other normal transactions.
- If MME receives paging request with priority from MSC, MME and eNodeB shall be able to page the normal terminating UE in prioritized way to establish the radio and S1 connection for subsequent CS Fallback procedures.

5.4.1.2 Mobile-originated GERAN/UTRAN CS Fallback call by a Service User

- MME and eNodeB shall be able to provide prioritized treatment for mobile originated GERAN/UTRAN CS Fallback originated by an authorized Service User.

5.4.2 CS Fallback to 1xRTT

For CS Fallback to 1x CS, MPS shall support a mechanism to properly handle priority voice calls and enable the terminating user and/or the call-originating Service User to establish the AS and NAS connection to fallback to 1x CS.

Priority MO or MT 1xCSFB with enhanced 1xRTT CS fallback procedure shall be executed without the concurrent PS handover procedure.

The architectural requirements to achieve priority handling for 1x CS Fallback MPS scenarios are the following:

5.4.2.1 Mobile-terminated 1xCSFB call originated by service-user in 1xRTT

- If the MME receives a message from 1xCS IWS which includes a prioritized 1x CS Paging request, handling of the message should be in accordance with the priority level indicated in the request (i.e. independent of the fact that request originated in the 1xRTT network).
- If the MME receives a message from 1xCS IWS which includes a prioritized 1x CS Paging request, the MME and eNodeB shall be able to page the terminating UE in prioritized way to establish the radio and S1 connection for subsequent CS Fallback procedures.

5.4.2.2 Mobile-originated 1xCSFB call by a service-user

- The MME and eNodeB shall be able to provide prioritized treatment for a 1xCSFB request originated in E-UTRAN by a service-user.

5.5 SRVCC

When SRVCC is being applied and the call is a priority call, the network entities shall assign priority level to voice that can be mapped to priority level used in CS domain. In order to provide priority for SRVCC:

- For SRVCC to GERAN/UTRAN:
 - The MME shall be able to detect that the session requires priority handling in the target system, and notify the priority information to the MSC/MGW in order for the target system to allocate CS and IMS network resources with priority.
 - The MSC shall notify the priority indication to the IMS for priority handling in IMS level, e.g. session transfer.
 - The source system notifies the priority information to the target system in order for the RNC/BSS to allocate network resources with priority in case of congestion situation.
 - The MSC Server shall be able to derive the IMS priority to be used for the access transfer from the information priority information provided from MME. The transfer request to IMS from MSC should have the same priority as the original session over IMS.

6 Key Issues for MPS

Editor's Note: This clause will describe the proposed solutions to meet the architecture requirements in clause 5.

6.1 IMS Multimedia Priority Services

Editor's Note: This clause will describes the key issues for IMS based multimedia priority service including the aspect of interworking between IMS and EPS bearer.

6.1.1 Key Issue 1 - Mobile Originated MPS Voice Session

6.1.1.1 Description

Call-flow is required to capture mobile originated MPS Voice Session.

6.1.1.2 Solution

Figure 6.1.1.2-1 shows the call flow for a mobile originating MPS session.

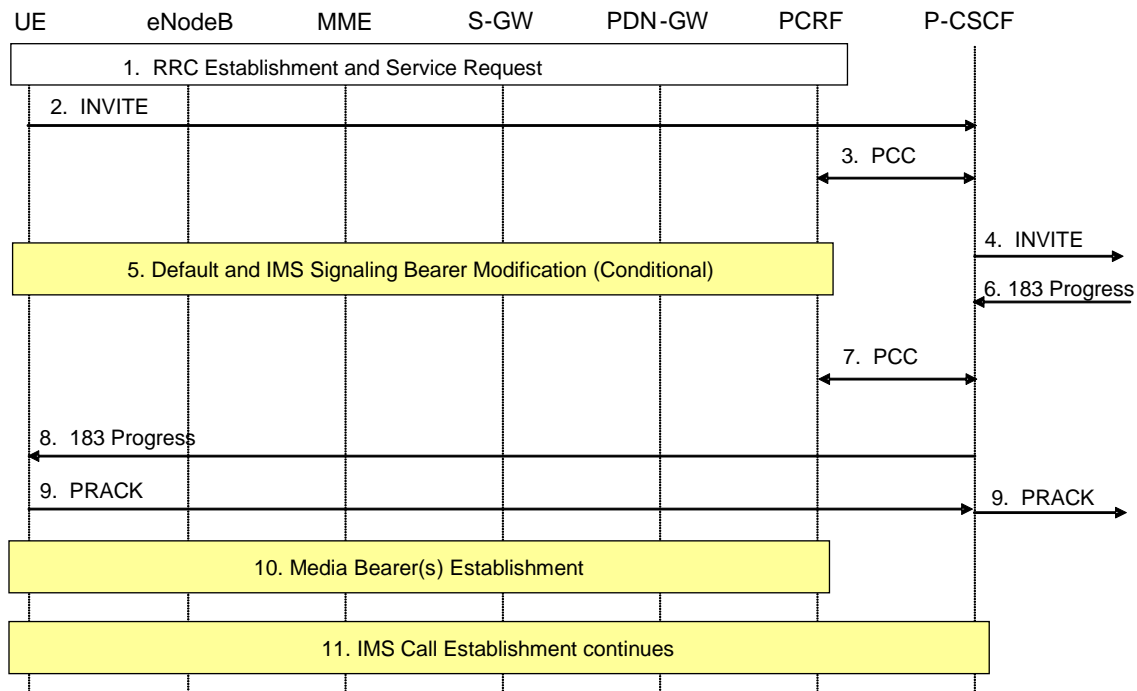

Figure 6.1.1.2-1: Mobile Originated MPS Voice Session

- 1. RRC Establishment and Service Request:** If the UE is in EMM-CONNECTED state, this step is not required. Else the UE establishes RRC connection as per TS 23.401 [3] clause 5.3.2.1. Since the Service User has an access class in the range of 11-15, the Establishment Cause in RRC connection request is set to highPriorityAccess. When the MME receives mobile initiated signalling with establishment cause set to highPriorityAccess, the MME and eNodeB prioritize RRC connection requests and establish the S1 bearer and radio resources with priority.
- 2. INVITE:** The UE sends a SIP INVITE message to the P-CSCF on a pre-established default or dedicated EPS bearer used to transport IMS/SIP signalling. The MPS code/identifier and destination address or the MPS input string supplied by the Service User is the SIP message. The P-CSCF detects voice session origination invoked by MPS code identifier or MPS input string and derives the session information.
- 3. PCC Interaction:** The P-CSCF invokes dynamic policy and forwards the derived session information by communicating with the PCRF. The P-CSCF provides information that the originating session is from a Service User. The PCRF recognizes that this request is associated with an MPS session and should be given priority treatment. The PCRF stores the received session information and identifies the affected IP-CAN session.
- 4. INVITE:** The P-CSCF forwards the SIP INVITE message to the Serving CSCF (S-CSCF).
- 5. Modification of Default and dedicated EPS Bearer used to transport IMS/SIP Signalling:** The PCRF checks if the ARP of the EPS bearer (default or dedicated) that is used to transport IMS/SIP signalling has a value appropriate for the MPS session. If the ARP of the EPS bearer that is used to transport IMS/SIP signalling is not appropriate for the MPS session, the PCRF modifies the ARP of the EPS bearer that is used to transport IMS/SIP signalling to a value appropriate for the MPS session. If the IMS/SIP signalling traffic is transported over a dedicated EPS bearer, then the PCRF modifies the ARP of the default EPS bearer of the same PDN connection to ensure the IMS signalling transported over a dedicated EPS bearer and default EPS bearer have an ARP value appropriate for MPS service, in order to avoid being released due to congestion. This may also be done, based on the operator's policy, to give priority for setting up signalling for early media to collect additional credentials from a Service User in case of priority call origination from any UE.
- 6. 183 Progress:** The IMS core receives a "183 Progress" message in response to the SIP INVITE. The P-CSCF identifies that the session belongs to MPS and the Service User's priority level. The P-CSCF maps the AF-Application Identifier and the Reservation-Priority AVPs with appropriate settings for the MPS session.
- 7. PCC Interaction:** The P-CSCF authorises the QoS resources and invokes dynamic policy. The PCRF stores the received session information and identifies the affected IP-CAN session.
- 8. 183 Progress:** The P-CSCF forwards the 183 Progress message to the UE.

9. P-RACK: After receiving 183 Progress message, the UE sends a SIP P-RACK message to the P-CSCF as a response to the 183 Progress message.
10. Media Bearer(s) Establishment: The PCRF initiates the establishment of dedicated EPS bearer(s) to transport the media traffic for the MPS session. The dedicated EPS bearer media is handled with priority in EPS. In case the MPS session is not authorized and is required to collect additional credentials from the Service User, based on the operator's policy, priority may be provided to the EPS bearers that are used for the authorisation of the Service User.

NOTE 1: The mechanisms and protocols used to collect additional credentials from the Service User for authorization of the MPS session are outside the scope of the TR.

11. IMS call establishment procedure continues.

NOTE 2: If the call fails or is rejected during the call establishment process or when the call is released and if no other MPS calls are in progress the PCRF downgrades the ARP of the Default and EPS bearer that were used to transport IMS/SIP signalling back to its original value.

6.1.1.3 Impacted entities in the System

P-CSCF needs to detect MPS code/identifier or the MPS input string in the SIP INVITE message and provide service information to the PCRF. When the PCRF receives service information from the IMS network, it needs to check if the existing default bearer and dedicated EPS bearer that is used to transport IMS/SIP signalling are appropriate for MPS and if they are not, the PCRF initiates modifying these bearers. When the PCRF receives information that the IMS session is authorized, and receives the authorized priority of the session, the PCRF initiates the media bearer establishment with priority in the EPS. When the PCRF receives an indication from the IMS network that the session is MPS, but the authorization is not completed, if necessary as determined by the operator's policy, the PCRF may provide priority to collect additional credentials from the Service User. When the MME receives a request to modify or establish a bearer with an ARP appropriate for an MPS session, the MME and eNodeB establish the S1 bearer and radio resources with priority. When the MME receives mobile initiated signalling with an establishment cause set to highPriorityAccess, the MME and eNodeB prioritize the RRC connection requests and establish the S1 bearer and radio resources with priority.

6.1.2 Key issue 2 - QoS handling for IMS multimedia priority Service

6.1.2.1 Description

If the IMS Multimedia Priority service is invoked the related EPS bearer used for IMS Multimedia Priority service media and IMS/SIP signalling will receive priority treatment.

The QCI parameter is used to control bearer level packet forwarding treatment. It is not needed to upgrade the QCI of MPS service related EPS bearer or add some indicator to differentiate the MPS service related EPS bearer against the non MPS service related EPS bearer with the same QCI.

To assure the MPS service related EPS bearers receive priority treatment comparing to the non MPS service related EPS bearers when network need release EPS bearer due to congestion. The ARP setting of the EPS bearers need to be upgraded if these EPS bearers are changed from non MPS service related EPS bearer to MPS service related EPS bearers.

6.1.2.2 Solution

As the IMS media bearer will be established after the IMS session of the MPS service has been established, it can be assigned with correct ARP value when it is established. However IMS/SIP signalling related EPS bearer needs to be upgraded if it has not been assigned with the appropriate ARP setting for the MPS service when the IMS session of the MPS service has been initiated.

Also to avoid default bearer can not be allocated resource due to the low ARP priority value in the handover case, for the MPS service related PDN connection it is necessary to assure the ARP value of the default bearer receives the appropriate ARP setting for MPS service.

6.1.2.3 Impacted entities in the System

PCRF needs to assure that the ARP setting of the EPS bearer that is used to transport the IMS/SIP signalling and the default bearer of that PDN connection are assigned with the appropriate ARP setting for MPS service when it received the MPS service activation indication from P-CSCF.

When IMS media bearer of MPS service is established, the PCRF needs to assure that the ARP value of that bearer is assigned with the appropriate ARP setting for MPS service.

6.1.3 Key issue 3 - Mobile-terminating IMS multimedia service to a user in E-UTRAN

6.1.3.1 Description

In Rel-9 for Mobile-terminating IMS multimedia service originated by the Service User, following issues needs to be resolved.

1. There is no mechanism for P-GW and S-GW to identify the priority indication and further prioritize the handling internally.
2. When the MME receives the downlink data notification, it may reject the downlink data notification under congestion situation as MME cannot distinguish whether it is the request for priority service.
3. There is no mechanism for the system to page the terminating UE and allow it to establish the AS and NAS signalling connection for subsequent resource allocation/maintaining in prioritized way.

Due to lack of above capabilities, there is a case where the MT IMS multimedia service triggered by the Service User cannot be completed successfully under network congestion situation, e.g. MME and eNodeB congestions.

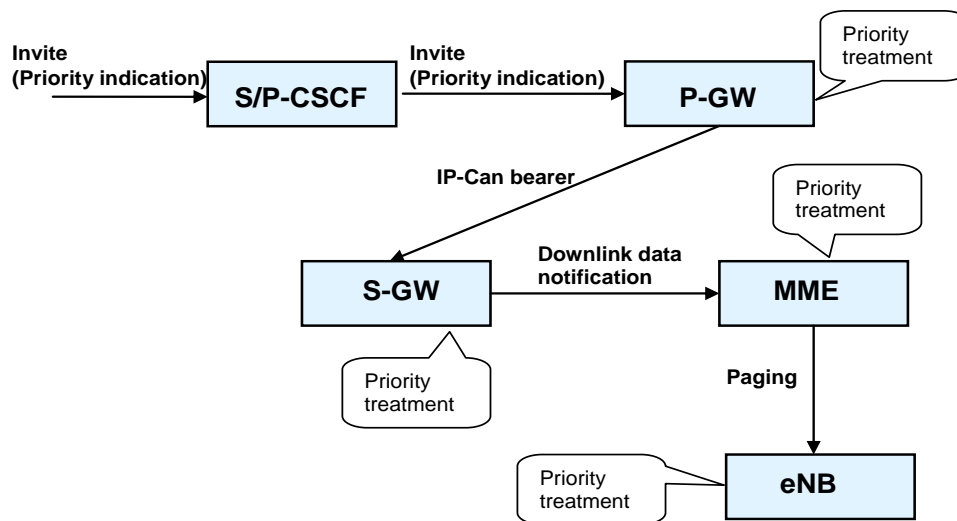

Figure 6.1.3.1-1: Capability required for mobile terminating IMS multimedia service originated by a Service User

6.1.3.2 Solution

6.1.3.2.1 Terminating MPS session to users when the existing ARP of the default bearer and IMS signalling bearer is not consistent with MPS use

The following procedure shows the terminating MPS session procedure to UE when the existing ARP of the default bearer and IMS signalling bearer is not consistent with MPS use.

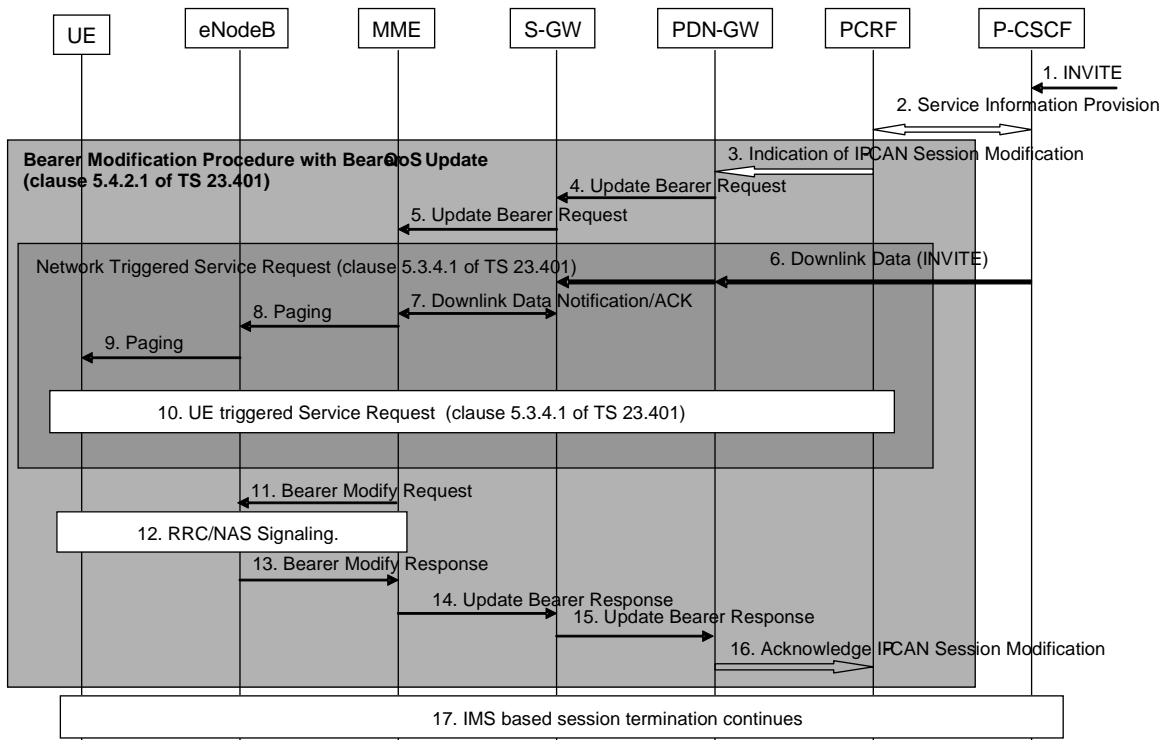

Figure 6.1.3.2.1: PCRF initiated Bearer Modification Procedure with priority handling

1. The P-CSCF receives the SIP INVITE which includes MPS session indication and the originating Service User's priority level and performs service information provision in step 2. The bearer modification procedure (step 2) and SIP INVITE message forwarding (step 6) are performed in parallel.
2. P-CSCF provides service information to the PCRF including the MPS session information and Service User priority level. The PCRF stores the service information and sends the Ack back to the P-CSCF.
3. The PCRF makes the policy decision. If the existing ARP of the default bearer and IMS signalling bearer is not consistent with the desired ARP for MPS session, the PCRF initiates Bearer Modification Procedure with Bearer QoS Update as defined in clause 5.4.2.1 of TS 23.401 [3].

The PCRF sends the Policy and Charging Rules Provision to the PDN GW with appropriate QoS parameters (including the desired ARP) for the PCC rules pertaining to the default and IMS signalling bearers.

NOTE 1: In case of PMIP based S5, the PCRF sends the Gateway Control and QoS Rules Provision to the Serving GW with the desired ARP.

4. For GTP-based S5/S8, the PDN GW enforces the decision and sends the Update Bearer Request message to the Serving GW to modify the ARP of the existing default bearer and IMS signalling bearer.
5. The Serving GW sends the Update Bearer Request message to the MME to modify the ARP of the existing default bearer and IMS signalling bearer. The MME updates the contexts to reflect the appropriate ARP for the default and IMS signalling bearers. If ISR is activated, instead of sending Update Bearer Request message to the MME, S-GW buffers the Update Bearer Request message and sends a Downlink Data Notification message to the MME. The message includes the priority indication, i.e. ARP, contained within the Update Bearer Request that is intended to be applied to the default bearer and IMS signaling bearer. If the Serving GW already sent the Downlink Data Notification without priority to MME and is waiting for the user plane to be established, the SGW shall immediately send the Downlink Data Notification message again with priority. The MME sends a response to the S-GW.

NOTE 2: Priority indication format in Downlink Data Notification is to be confirmed in Stage3.

6. The P-CSCF sends the SIP INVITE message (i.e. as Downlink Application Layer Data to the PDN GW and the PDN GW forwards it to the Serving GW).

7. If the UE is in ECM-CONNECTED state, this step 7 and the following steps 8, 9, and 10 are not performed. If the Serving GW determines that there is no downlink user plane established for the UE over the S1-U, the Serving GW sends a Downlink Data Notification message to the MME.
8. The MME sends Paging together with priority indication appropriate for an MPS session to the eNodeB according to the indicated ARP.

If the MME already sent the paging message without priority and is waiting for the paging response, the MME shall immediately send Paging together with priority indication appropriate for an MPS session to the eNodeB again, e.g. MME receives Downlink Data Notification without priority in step 7 and afterwards receives Update Bearer Request with priority in step 5. Otherwise, if the MME already sent the paging message with priority and is waiting for the paging response, the MME shall not send Paging with priority again, i.e. MME receives Update Bearer Request in step 5 and afterwards receives Downlink Data Notification with priority in step 7.
9. The eNodeB processes the Paging from MME according to the indicated priority and sends RRC Paging message to the UE. The priority handling mechanism at eNB is based on operator policy.
10. The UE initiates the UE triggered Service Request procedure as specified in clause 5.3.4.1 of TS 23.401 [3]. After the downlink S1-U bearer has been established, S-GW forwards to the UE all IMS signalling bearer downlink data (which includes the SIP INVITE message) that was buffered if the UE was in ECM-IDLE state in step 6.

NOTE 3: In order to avoid a congestion situation at eNodeB, eNodeB may initiate the access control which prevents normal users from making access attempts in specified areas of a PLMN.

11. The MME sends a Bearer Modify Request to the eNodeB.
12. If ISR is activated, the MME builds a Session Management Request as described in step 4 of the Bearer Modification Procedure in clause 5.4.2.1 of TS 23.401 [3] and performs the corresponding Session Management procedure. If ISR is not activated and only the QoS parameter ARP is modified, this step 12 is skipped.

NOTE 4: If the UE is in ECM-IDLE state, steps 11, 12 and 13 can be combined with the Service Request procedure in step 10 or be performed standalone (see clause 5.4.2.1 of TS 23.401 [3]).

13. The eNodeB responds to the MME with a Bearer Modify Response to the request received in step 11.
14. The MME sends the Update Bearer Response to the S-GW.
15. The S-GW sends the Update Bearer Response to the PDN-GW.

NOTE 5: In case of PMIP based S5, the Serving GW sends the Gateway Control and QoS Rules Ack to the PCRF.

16. If the PCRF requested an acknowledgement for Indication of IP-CAN Session modification, then the PDN-GW sends the Acknowledge IP CAN Session Modification Message to the PCRF.
17. The IMS-based session termination procedure continues over the IMS signalling bearer, and priority treatment applies in the event of congestion when establishing the corresponding bearer(s) for the session.

NOTE 6: If the call fails or is rejected during the call establishment process or when the call is released and if no other MPS calls are in progress, the PCRF downgrades the ARP of the Default and EPS bearer that were used to transport IMS/SIP signalling back to its original value.

6.1.3.2.2 Terminating MPS session to users when the existing ARP of the default bearer and IMS signalling bearer is already consistent with MPS use

The following procedure shows the terminating MPS session procedure to UE when the existing ARP of the default bearer and IMS signalling bearer is already consistent with MPS use.

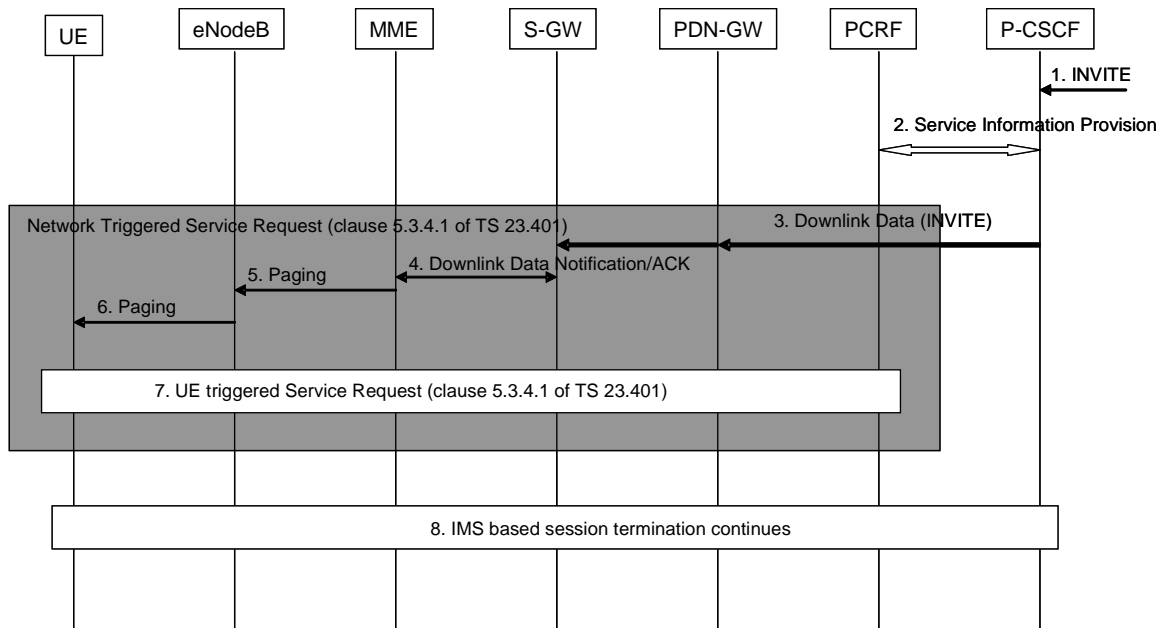

Figure 6.1.3.2.2: Network initiated Paging Procedure with priority handling

1. The P-CSCF receives the SIP INVITE which includes MPS session indication and the originating Service User's priority level.
2. P-CSCF provides service information to the PCRF including the MPS session information and Service User priority level. The PCRF stores the service information and sends the Ack back to the P-CSCF. The PCRF makes the policy decision. If the existing ARP of the default bearer and IMS signalling bearer is consistent with the desired ARP for MPS session, then Bearer Modification Procedure with Bearer QoS Update is not performed.
3. The P-CSCF sends the SIP INVITE message (i.e. as Downlink Application Layer Data to the PDN GW). The PDN GW forwards the downlink data to the Serving GW over the established EPS bearer for IMS signalling.
4. If the Serving GW determines that there is no downlink user plane established for the UE over the S1-U, the Serving GW sends a Downlink Data Notification message to the MME with "priority-indication". The message includes the ARP of the EPS bearer over which Downlink Data Packet (for SIP INVITE) arrived that represents the priority applied to the IMS signaling bearer. If the Serving GW already sent the Downlink Data Notification without priority to MME and is waiting for the user plane to be established, the SGW shall immediately send the Downlink Data Notification message again with priority. The MME sends a response to the S-GW.
5. The MME sends Paging together with priority indication appropriate for an MPS session to the eNodeB according to the indicated ARP.

If the MME already sent the paging message without priority and is waiting for the paging response, the MME shall immediately send Paging together with priority indication appropriate for an MPS session to the eNodeB again, e.g. MME receives Downlink Data Notification without priority for non MPS related service and afterwards receives Downlink Data Notification with priority in step 4.

The eNodeB processes the Paging from MME according to the indicated priority and sends RRC Paging message to the UE. The priority handling mechanism at eNB is based on operator policy.

6. The UE initiates the UE triggered Service Request procedure as specified in clause 5.3.4.1 of TS 23.401 [3].

NOTE: In order to avoid congestion situation at eNodeB, eNodeB may initiate the access control which prevents normal users from making access attempts in specified areas of a PLMN.

7. The IMS-based session termination procedure continues over the IMS signalling bearer, and priority treatment applies in the event of congestion when establishing the corresponding bearer(s) for the session.

6.1.4 Key Issue 4 - Priority information download procedure

6.1.4.1 Description

To recognize the MPS service on IMS application level, the P-CSCF needs subscriber's profile of service priority level.

6.1.4.2 Solution

The figure 6.1.4.2-1 shows the priority information download procedure.

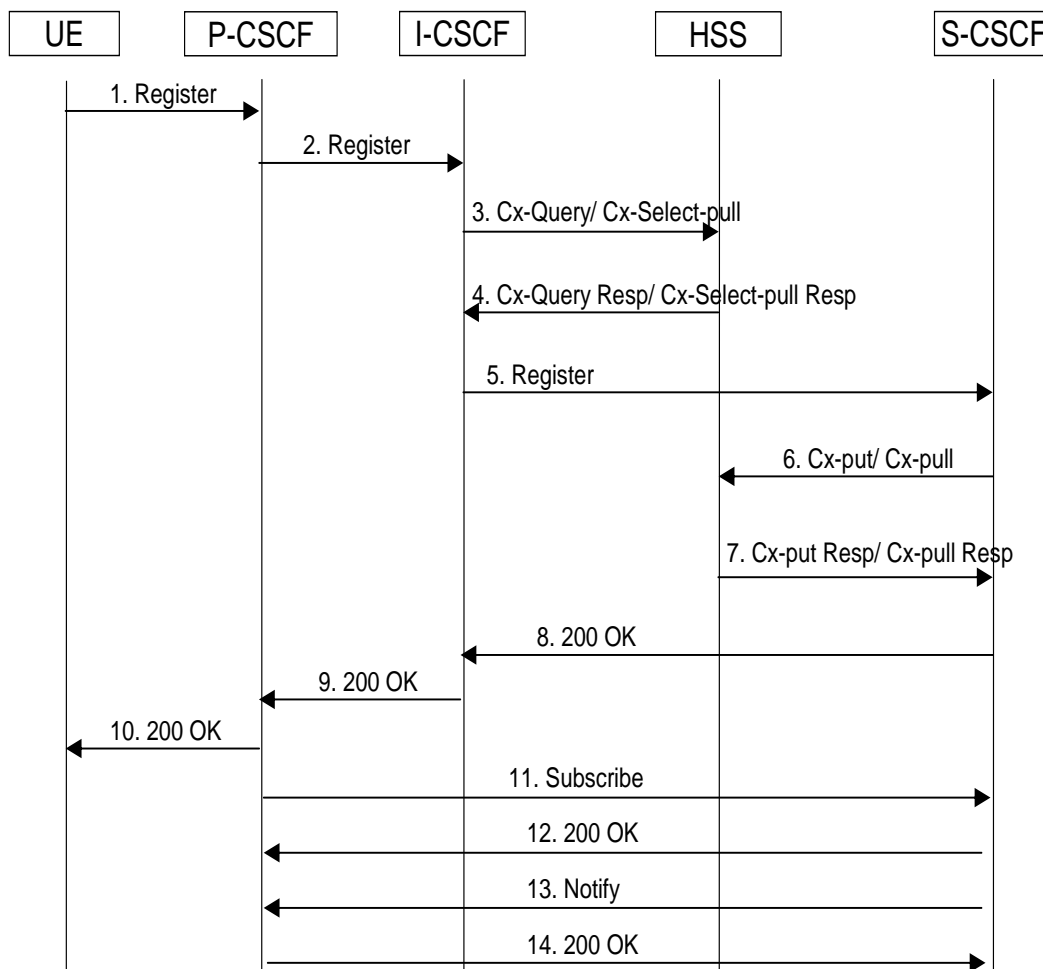

Figure 6.1.4.2-1: IMS Registration Flow

1-6. These steps do not change from the corresponding IMS Registration procedures specified in TS 23.228 [12].

7. The S-CSCF receives the priority information, i.e. Service Priority Level, for the MPS-subscribed UE from HSS, and maintains it as a part of user profile. (See TS 24.229 [13] and TS 29.228 [14] for details).

8-14. The priority information is sent to P-CSCF. The P-CSCF stores this information for the MPS-subscribed UE.

NOTE: CT WG1 is discussing various mechanisms on how to transfer the priority status between S-CSCF and P-CSCF.

The figure 6.1.4.2-2 shows the SIP message handling for IMS MO call initiated by the MPS-subscribed UE.

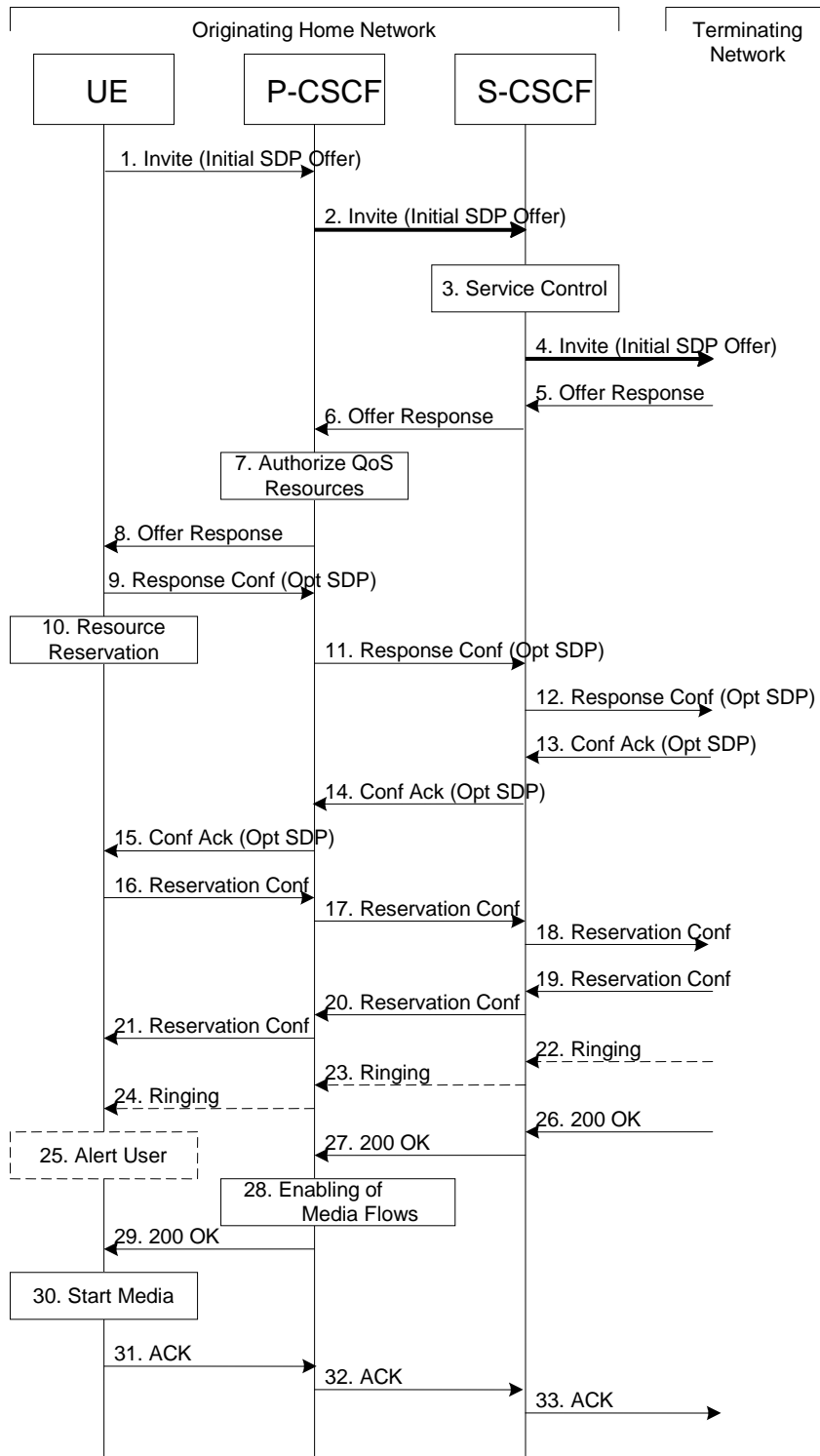

Figure 6.1.4.2-2: IMS MO call procedure initiated by the MPS-subscribed UE

Step 1 does not change from the corresponding IMS MO call procedures specified in TS 23.228 [12] and TS 24.229 [13].

2. P-CSCF judges whether the INVITE message requires the priority handling based on user profile stored during the registration procedure and/or the priority requested by the user and/or MPS code/identifier provided by INVITE message. If the session is determined to have priority handling, then P-CSCF inserts/replaces the priority indication and forwards it to the S-CSCF.

Step 3 does not change from the corresponding IMS MO call procedures specified in TS 23.228 [12] and TS 24.229 [13].

4. S-CSCF will treat the INVITE request based on the priority indication received from the P-CSCF. S-CSCF then forwards the INVITE to the next node with this priority indication.

Following Steps do not change from the corresponding IMS MO call procedures specified in TS 23.228 [12] and TS 24.229 [13].

6.1.5 Key Issue 5 – Priority resource handling in SRVCC

6.1.5.1 Description

As described in the following bullets, there is no capability for MME, MGW/MSC server and MSC to inform priority indication to neighbour nodes e.g. MSC Server or RNC/BSS during handover preparation.

There is no capability for MME to inform priority indication to MSC Server/MGW and MSC server in the core network.

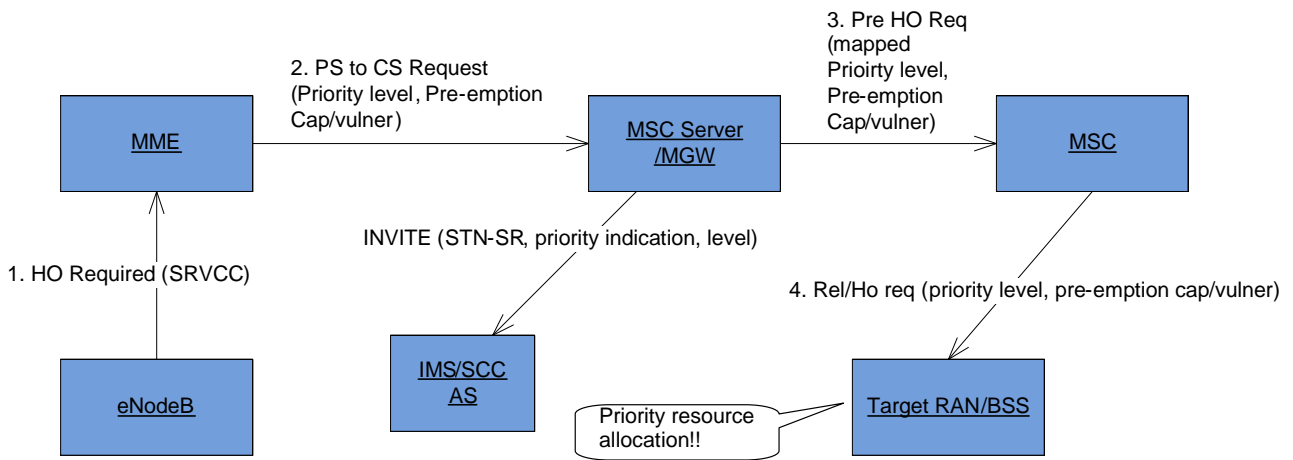

Figure 6.1.5.1-1 Capability required for PS to CS handover in SRVCC

Due to lack of above capabilities, there is a case where the SRVCC procedure is triggered for the IMS based priority call may fail if target network, i.e. UTRAN/GERAN and/or CS core network, is in congested situation. Therefore, it shall be possible for MME, MGW/ MSC server and MSC to notify the target RAT of the priority indication and target RAT and CS core network allocate its radio and core network resources for the IMS based priority call.

6.1.5.2 Solution

The solution for priority handling of radio resource in SRVCC procedure is illustrated in Figure 6.1.5.2-1.

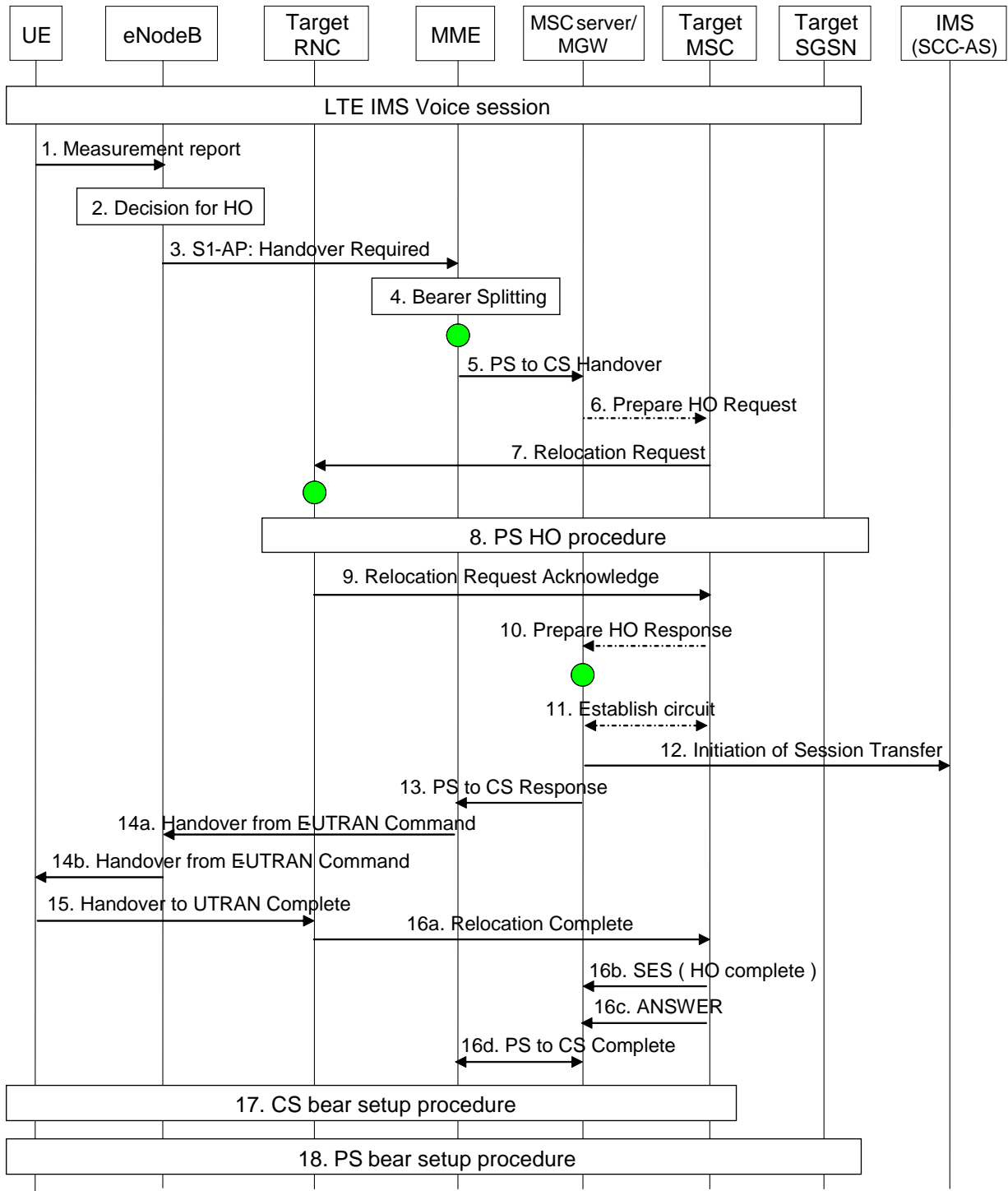

Figure 6.1.5.2-1: Priority handling of SRVCC from E-UTRAN to UTRAN/GERAN.

The key modifications to the basic flow for providing MPS service are as follows:

- 0. Based on IMS based priority call handling mechanism, eNodeB and MME recognizes that the ongoing session is an IMS based MPS session. The SCC AS is also aware the IMS MPS session(s) during the IMS based MPS session establishment procedures as defined in TS 23.228 [12], i.e. during the session establishment procedure.

From Step 1 to Step 2, the procedure does not change from the corresponding SRVCC procedures specified in TS 23.216 [16].

3. The eNodeB sends "Handover required message" to the MME.

Step 4 does not change from the corresponding SRVCC procedure specified in TS 23.216 [16].

5. MME detects the session requires priority handling based on the priority indication (i.e. ARP) associated with IMS CN signalling (i.e. QCI-5) received during the IMS based MPS session establishment and sends the SRVCC PS to CS Request message to the MSC Server/MGW by sending a priority indication (i.e. ARP) for the ongoing IMS call in the PS to CS Handover message to MSC Server. The priority indication is used by the target RNC/BSS to determine whether the call needs priority during congestion for its resource allocation.
6. Based on the priority indication (i.e. ARP) in the SRVCC PS to CS Request, the MSC server/MGW sends Prepare Handover Request message to the Target MSC with priority indication mapped from the ARP. The MSC Server maps the ARP to the priority level, pre-emption capability/vulnerability for CS services based on local regulation or operator settings. The priority indication indicates the CS call priority during handover as specified in TS 25.413 [5] for UMTS and TS 48.008 [18] for GSM/EDGE.
7. The target MSC sends "Relocation Request/Handover Request" to the RNC/BSS. The RNC/BSS allocates the radio resource based on the existing procedures with priority indication, as specified in TS 25.413 [5] for UMTS and TS 48.008 [18] for GSM/EDGE.

Both Step 8 and step 9 do not change the corresponding SRVCC procedure specified in TS 23.216 [16].

10. The target MSC sends a Prepare Handover Response message to the MSC server with priority indication.
11. When the MGW receives a Handover Response in step 10, the CS bearer is established in prioritized way between the target MSC and the MGW associated with the MSC Server.
12. MSC Server sends the SIP Session Transfer message with the priority indication to the IMS and the IMS entity handles the session transfer procedure with priority. The priority indication in the SIP Session Transfer message is mapped by the MSC Server from the priority indication (i.e. ARP) in the SRVCC PS to CS Request received in step 5. The mapping of the priority level is based on operator policy and/or local configuration, and the IMS priority indicator should be the same as for the original IMS created over PS.

From Step13 to Step18, the procedure does not change from the corresponding SRVCC procedures specified in TS 23.216 [16].

NOTE: The priority handling procedures for CS handover is defined in TS 23.009 [17], TS 48.008 [18], and TS 25.413 [5]. It is not expected to change due to SRVCC HO.

6.2 Priority EPS Bearer Service

Editor's Note: This clause will describes the key issues for EPS bearer priority when IMS is not used as service layer.

6.2.1 Key issue1 - QoS of Default Bearer Assignment for an Always-On MPS Subscription

6.2.1.1 Description

When attaching to the network, UE is given a default bearer, which it may use for signalling any requests for services to the network. This clause discusses QoS parameters assignment given to the default bearer when a Service User having an Always-On MPS subscription attaches to the network to ensure UE's PDN connection is admitted and not pre-empted during the congestion.

6.2.1.2 Solution

This clause describes the signalling flow for IP-CAN Session establishment for a UE with an Always-On MPS subscription. The profile downloaded from the SPR includes a priority indication. In this case the rules installed into the

PDN GW will include the appropriate QoS attributes (e.g. ARP, QCI). These attributes will be assigned by the PDN GW to the EPS Bearer.

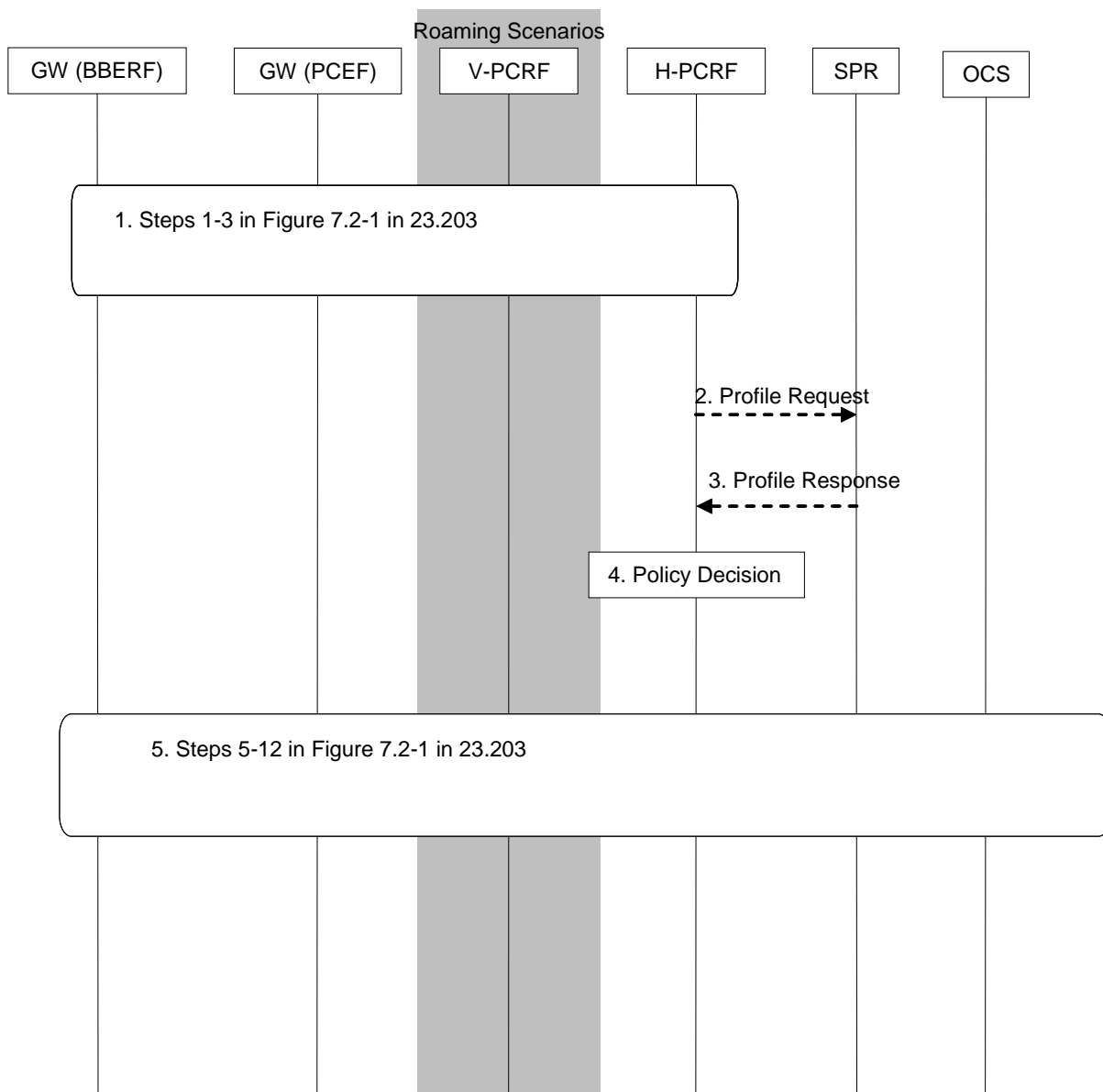

Figure 6.2.1.2.1: IP-CAN Session Establishment

1. Steps 1-3 for an IP-CAN Session Establishment procedure with PCC as in TS 23.203 [15], Figure 7.2-1.
2. If the PCRF does not have the subscriber's subscription related information, it sends a request to the SPR in order to receive the information related to the IP-CAN session. The PCRF provides the subscriber ID and, if applicable, the PDN identifier to the SPR. The PCRF may request notifications from the SPR on changes in the subscription information.
3. The user profile downloaded from the SPR includes a priority indication for establishing an PS session with priority. The PCRF stores the subscription related information containing the information about the allowed service(s) and PCC Rules information.
4. The PCRF makes the authorization and policy decision. The priority indication is used to apply operator specific policy and configuration to derive necessary QoS parameters (e.g. ARP, QCI) for establishing an MPS session.
5. Steps 5-12 for an IP-CAN Session Establishment procedure with PCC as in TS 23.203 [15], Figure 7.2-1.

6.2.2 Key issue2 - Priority Invocation/Revocation

6.2.2.1 Description

Depending on the system design or operator choice, priority for EPS bearer services can be given permanently to a Service User, or can be provided only if specifically requested by the Service User (on-demand). If configured for permanent priority, initial attach constitutes an invocation of priority for EPS Bearer services. If however, on-demand priority is required, a mechanism for invocation should be elaborated upon. Details for each case of priority invocation should be investigated.

If priority is invoked at a time that user is already engaged in EPS bearer services, the interaction with the existing bearers will be done having the PCRF instruct the PDN-GW accordingly.

The indication of on-demand "Priority Status" can be communicated to the PCRF by Application Function (AF) for a session which is requesting priority. This can be done via the Rx interface. During the Priority invocation process, the applicable bearer shall be upgraded with proper priority level according to operator policy and configuration. After successful Priority Invocation, priority level for that bearer shall be derived according to operator policy and configuration.

During the Priority Revocation process, the existing bearers shall be modified to a proper priority level according to operator policy and configuration.

6.2.2.2 Solution

6.2.2.2.1 Solution 1: Upgrading/Downgrading priority (MPS) for Invoke/Revoke of On demand MPS

The solution relies on existing Rx procedures between the AF and the PCRF whereby the AF requests modification of existing AF session, to upgrade/downgrade priority of the UE's existing AF session(s).

The procedure used is the PCRF initiated IP-CAN session modification procedure in clause 7.4.2 of TS 23.203 [15]. The AF identifies the sessions to be affected and using existing Rx procedure requests the PCRF to upgrade or downgrade the priority of the existing AF sessions.

6.2.2.2.2 Solution-2: Always On MPS Activation

The solution relies on existing procedures between the SPR and the PCRF whereby the SPR notifies the PCRF when the subscriber's profile changes. Once the PCRF receives a notification of a change in the subscriber's profile (Priority EPS Bearer Service Invoked/Revoked) it triggers the PCRF initiated IP CAN Session Modification per TS 23.203 [15], clause 7.5, to upgrade or downgrade the QCI and/or ARP of existing GBR and non-GBR bearers (except for the signalling bearer) when EPS Priority Bearer service is invoked/revoked, respectively.

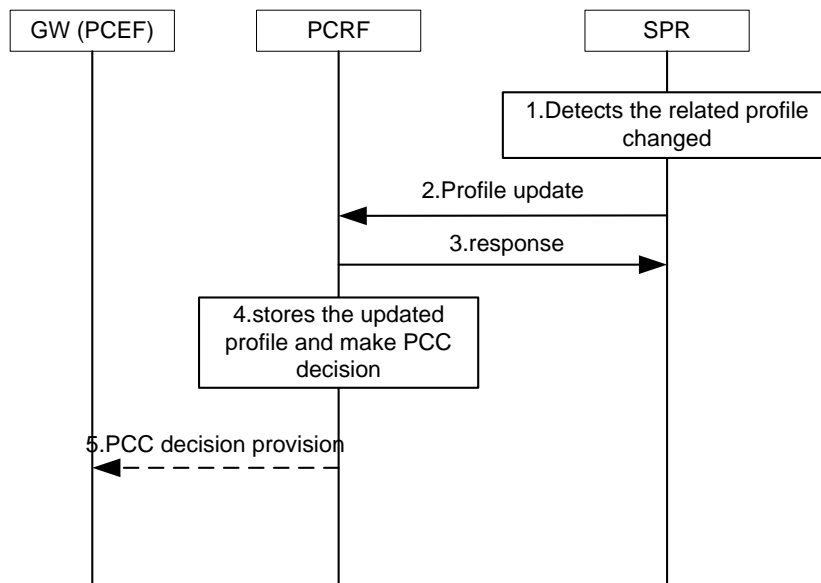

Figure 6.2.2.2-1: SPR Triggered IP CAN Session Modification procedure

1. The SPR detects that the related subscription profile of an IP-CAN session has been changed. For instance, the Priority EPS Bearer Service of a Service User has been invoked/revoked.
2. If requested by the PCRF, the SPR notifies the PCRF on the changed profile.
3. The PCRF responds to the SPR.
4. The PCRF stores the updated profile and makes resulting PCC decisions to upgrade/downgrade the ARP of the appropriate service data flows.
5. The PCRF provides all new PCC decisions to the PCEF, using the PCRF initiated IP-CAN session modification procedure in clause 7.4.2 of TS 23.203 [15]. The PCEF upgrades/downgrades the ARP of bearers.

6.2.2.3 Impacted entities in the System

6.2.2.3.1 Solution-1: Upgrading/Downgrading priority (MPS) for Invoke/Revoke of On demand MPS

6.2.2.3.2 Solution-2: Always On MPS Activation

The impacted entities are: SPR, PCRF

SPR:

New information elements/indicators are added to the user's profile to reflect the Always-on MPS subscription status. The new IEs/indicators shall be supported by the Sp interface.

PCRF:

PCRF updates all affected IP-CAN bearers.

6.3 CS Fallback

6.3.1 CS Fallback to GERAN/UTRAN

6.3.1.1 Key Issue1 - Priority handling of mobile terminating call

6.3.1.1.1 Description

In Rel-9 GERAN/UTRAN CS Fallback procedure for mobile terminating call originated by the Service User, following issues needs to be resolved.

1. There is no mechanism for MME to prioritize the handling of Paging Request with priority indication arrived from MSC.
2. There is no mechanism for eNodeB to page the terminating UE and allow it to establish the AS and NAS signalling connection for subsequent CS Fallback procedure in prioritized way.

Due to lack of above capabilities, there is a case where the CS Fallback procedure triggered by the call arrival from a Service User cannot be completed successfully under network congestion situation, e.g. MME and eNodeB congestions. Therefore, when MME detects the CS Fallback requires the priority handling, it shall be possible for the MME and eNodeB to handle the CS Fallback related procedure preferentially compared to other normal transactions as well as to page the UE and enable the terminating UE to establish the AS and NAS signalling connections.

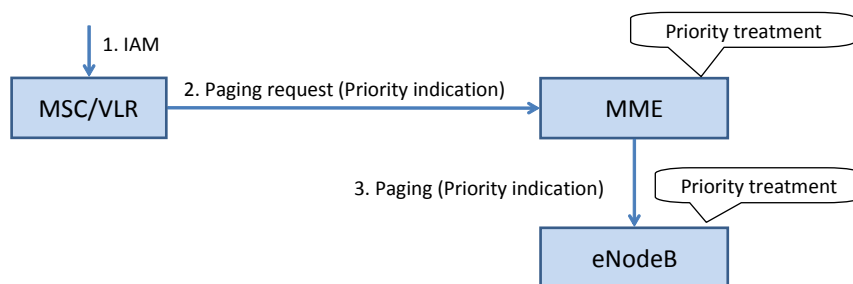

Figure 6.3.1.1.1: Capability required for mobile terminating call originated by a Service User

6.3.1.1.2 Solution

6.3.1.1.2.1 Priority handling of CS Fallback for Mobile Terminating Call in idle mode

The solution for priority handling of terminating call is illustrated in Figure 6.3.1.2.1.

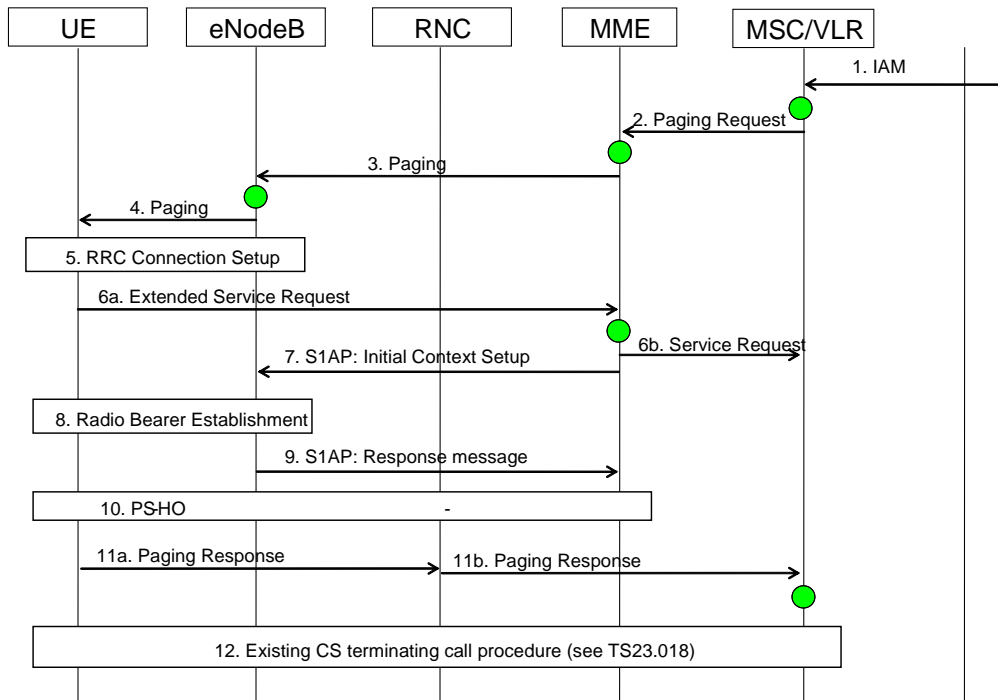

Figure 6.3.1.1.2.1: Priority handling of CS Fallback for Mobile Terminating Call in idle mode

NOTE: In order to avoid congestion situation at eNodeB, it may initiate the access control which prevents normal UE users from making access attempts in specified areas of a PLMN.

1. The MSC receives an IAM message with priority marking, e.g. eMLPP priority. In order to handle the CS call establishment procedure after step 11b, the MSC/VLR memorises that the UE is paged with priority.
2. The MME receives paging request message with priority indication, e.g. eMLPP priority, from the MSC, then the MME processes this message and also the subsequent CS fallback procedure preferentially compared to other normal transactions. For this purpose, the MME memorises that the UE is paged with priority.
3. The MME sends Paging with priority marking to the eNodeB.
4. With the priority indication in the received Paging, eNodeB sends Paging to the UE preferentially compared to other normal Pagings.
5. The UE and eNodeB establishes the RRC connection.
6. When MME receives Extended Service Request in Step 6a, it detects this message is the response to the priority CS Fallback procedure initiated in step 3, and the MME processes this message with priority.

From Step 7 to 10, procedure described in clause 6.3.1.2.2 of this TR is applied.

Step 11a does not change from the corresponding CS Fallback procedures specified in TS 23.272 [6].

- 11b. The MSC receives the paging response or Location Area Update Request and detects this message as the response to the priority CS Fallback procedure initiated in Step2 as currently specified. Then, the MSC continues with subsequent priority CS setup procedure.

12. Existing priority CS voice call establishment procedure for mobile terminating call is preformed, e.g. eMLPP.

6.3.1.1.2.2 Priority handling of CS Fallback for Mobile Terminating Call in Active mode

The solution for priority handling of terminating call is illustrated in Figure 6.3.1.1.2.2.

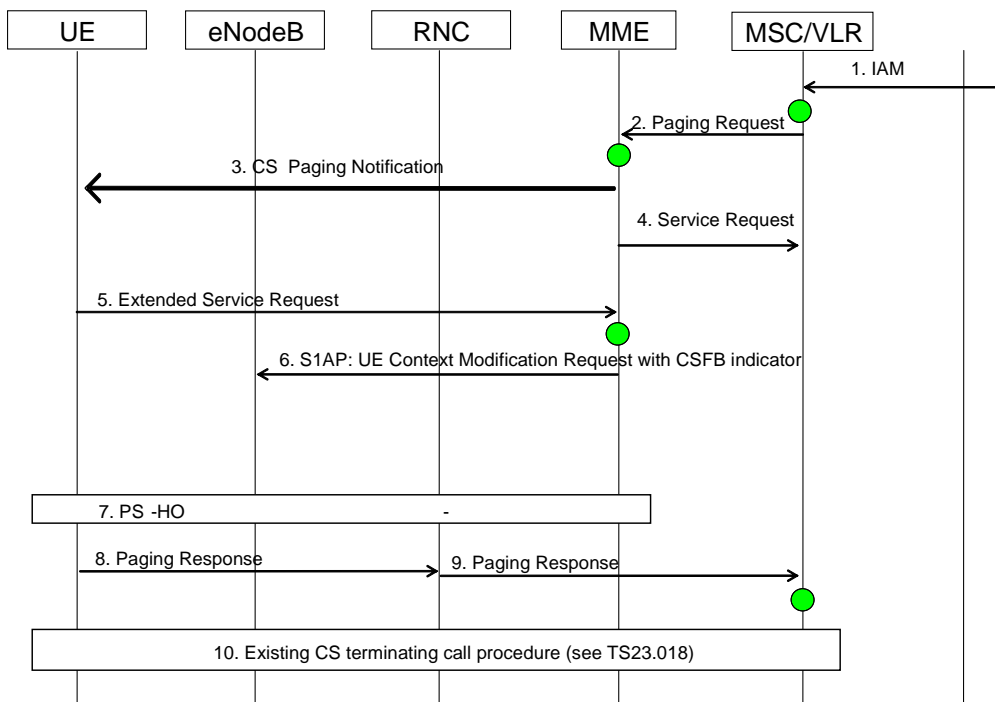

Figure 6.3.1.1.2.2: Priority handling of CS Fallback for Mobile Terminating Call in Active mode

1. The MSC receives an IAM message with priority marking, e.g. eMLPP priority. In order to handle the CS call establishment procedure after step 9, the MSC/VLR memorises that the UE is paged with priority.
2. The MME receives paging request message with priority indication, e.g. eMLPP priority, from the MSC, then the MME processes this message and also the subsequent CS fallback procedure preferentially compared to other normal transactions. For this purpose, the MME memorises that the UE is paged with priority.

From Step 3 to 5, does not change from the corresponding CS Fallback procedures specified in TS 23.272 [6].

From Step 6 to 7, procedure described in clause 6.3.1.2.2 of this TR is applied.

From Step 8 to 9, does not change from the corresponding CS Fallback procedures specified in TS 23.272 [6].

10. Existing priority CS voice call establishment procedure for mobile terminating call is preformed, e.g. eMLPP.

6.3.1.1.2.3 Priority handling of mobile terminating call when ISR active and SGs is active between MSC/VLR and MME

The solution for priority handling of terminating call when ISR active and SGs is active between MSC/VLR and MME is illustrated in Figure 6.3.1.1.2.3.

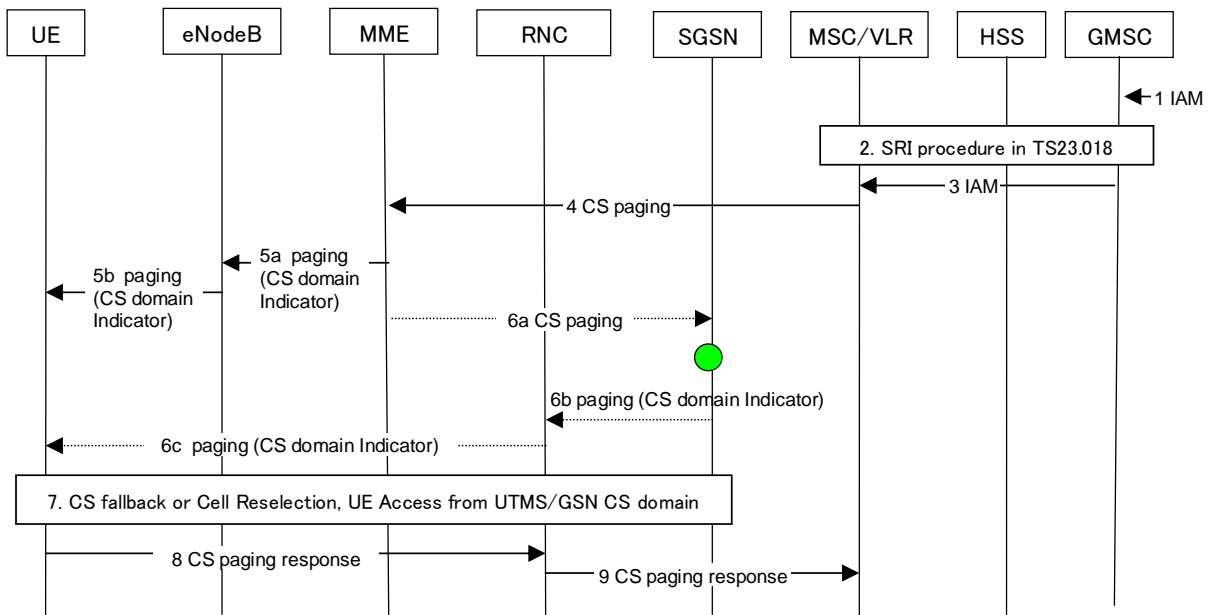

Figure 6.3.1.1.2.3: Priority handling of mobile Terminating Call when ISR active and SGs is active between MSC/VLR and MME

From Step 1 to Step 3 the procedure does not change from the corresponding CS Fallback procedures specified in TS 23.272 [6].

4. The MSC/VLR sends a Paging message to the MME via SGs with priority marking, e.g. eMLPP priority.

Steps 5a and 5b does not change from the corresponding CS Fallback procedures for Mobile Terminating Call in figure 6.3.1.1.2.1.

- 6a. The MME sends CS Paging message to the SGSN with priority marking, e.g. eMLPP priority. Then the SGSN treats this paging message preferentially compared to other normal transactions.

- 6b. The SGSN receives the CS paging message from the MME, then the SGSN sends paging messages to RNC/nodeB. SGSN may consider RNC overload condition as specified in TS 25.413 [5].

NOTE: If ISR is not active or the UE is in ECM-CONNECTED state, the MME does not send the CS paging message to the SGSN.

From Step 6c to Step 9 the procedure does not change from the corresponding CS Fallback procedures specified in TS 23.272 [6].

6.3.1.1.3 Impacted functions in the System

MSC maps priority indication of the IAM message to a priority indication of the paging message sent on the SGs interface.

In a congestion situation the MME should use this priority indication to process this message and also the subsequent CS fallback procedure preferentially compared to other normal transactions. For this purpose and for each paging attempt the MME memorizes that the UE is paged with priority. The MME forwards the paging message with priority indication to the eNodeB.

In a congestion situation the eNodeB should handle received paging messages with priority indication with preference over normal paging messages.

6.3.1.2 Key Issue2 - Priority radio resource handling in CS fallback

6.3.1.2.1 Description

If the CS Fallback is triggered when UE is in the Idle mode, MME requests the eNodeB to allocate the E-RAB resource. If the call is originated in scenarios described in clause 4.3.1, the following issue needs to be resolved.

1. There is no capability for MME to inform priority indication to eNodeB.

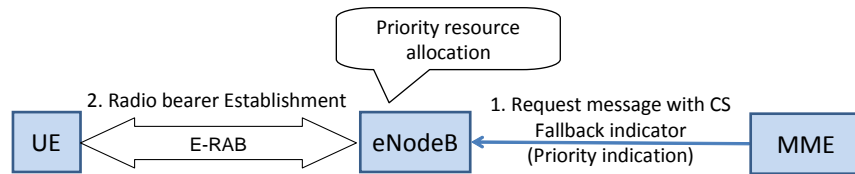

Figure 6.3.1.2.1-1: Capability required for MME and eNodeB for priority radio resource handling

Due to lack of above capability, there is a case where the CS Fallback procedure triggered in scenarios described in clause 4.3.1 will fail if E-UTRAN radio network is in congestion situation. Therefore, it shall be possible that the MME notifies the priority indication to the eNodeB in E-RAB resource request and the eNodeB allocates E-UTRAN radio bearer resources preferentially compared to other normal MT calls and PS services.

Another case is that if the CS Fallback with PS handover support is triggered, MME will initiate handover procedure to request the RNC to allocate the RAB resource in GERAN/UTRAN. If the resource allocation at RNC fails, it is considered that the PS handover fails and result in the failure of the CS Fallback. Therefore, it shall be possible that eNodeB allocates the priority indication to the RNC and the RNC allocates GERAN/UTRAN radio bearer resources preferentially compared to other normal MT calls and PS services. With this analysis, the following issue needs to be resolved.

2. There is no capability for eNodeB to inform priority indication to RNC in handover trigger.

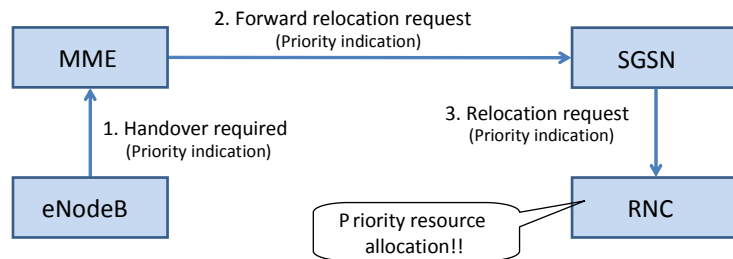

Figure 6.3.1.2.1-2: Capability required for PS handover in CS fallback

Due to lack of above capability, there is a case where the CS Fallback procedure triggered in scenarios described in clause 4.3.1 will fail if UTRAN radio network congestion situation. Therefore, it shall be possible for eNodeB to notify the RNC of priority indication and RNC to allocate UTRAN radio resources for the priority MT call.

6.3.1.2.2 Solution

The solution for priority handling of radio resource in CS fallback procedure is illustrated in Figure 6.3.1.2.2.

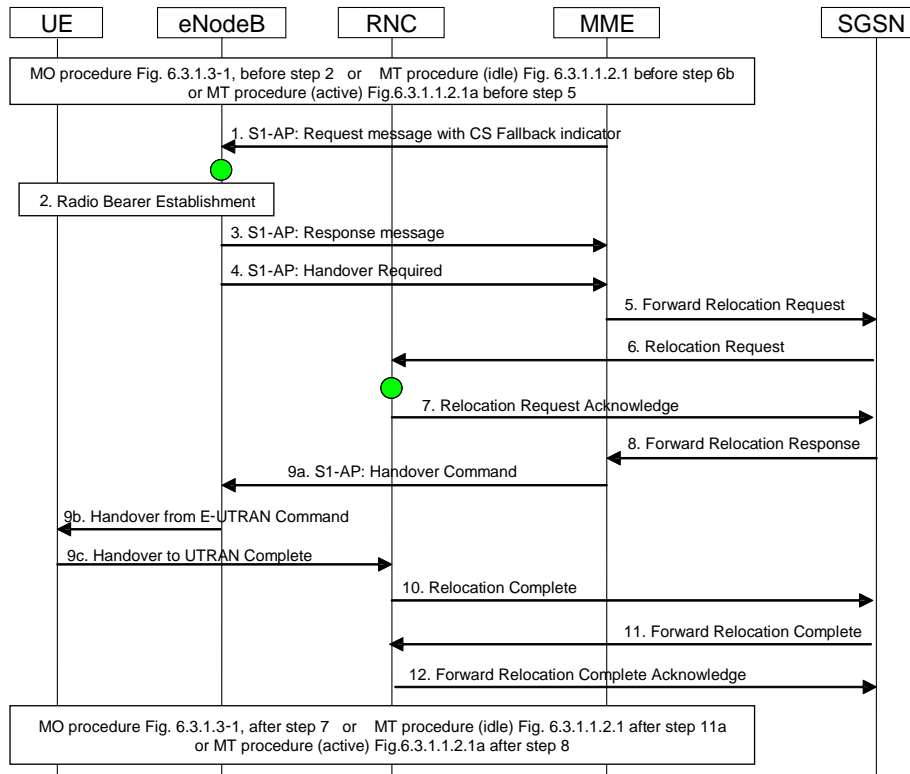

Figure 6.3.1.2.2: Priority handling of PS HO in CS fallback procedure

NOTE 1: In case of no PS handover support, only the priority radio resource allocation in E-UTRAN, i.e. from step 1 to step 3, applies.

- 1) The MME sends S1-AP request message to the eNodeB with priority indication. This message also includes the CS fallback indicator.

NOTE 2: The priority indication shall be able to set a different priority level from the one for the emergency call triggered CS fallback.

- 2) The eNodeB allocates radio bearer resources to the UE preferentially compared to other normal calls when the UE is in idle mode.

Step 3 does not change from the corresponding CS Fallback procedures specified in TS 23.272 [6].

NOTE 3: Based on operator policy, this indicator may be used by eNodeB to decide whether to continue CS Fallback procedures with PS HO, i.e. step 4, or to initiate radio release procedure to redirect the UE to 2G/3G Circuit Switch as specified in TS 23.272 [6].

- 4) The eNodeB may send "Hand over required message" to the MME with priority indication contained in Source to Target Transparent Container as specified in TS 25.413 [5]. In this case, the priority indication is forwarded to the target RNC transparently through the MME and SGSN. The indicator is used to show whether the call needs consideration on the priority level.

NOTE 4: As UTRAN/GERAN does not have "high-priority" indicator for handover in GPRS, normally, the priority indication in step 4 is considered as "normal call" which have lower priority handling at target RAT.

- 5) The MME sends "Forward relocation request message" to the SGSN

- 6) The SGSN sends "Relocation request" to the RNC. When RNC receives relocation request in Step 6 and if priority indication is sent in step 4, it detects this message is the priority CS Fallback procedure initiated in step 4, and the RNC may use this information to handle allocates the radio resource preferentially compared to other normal radio bearers, e.g. allocates the radio resource in prioritized way, as specified in TS 25.413 [5].

From Step7 to Step12, the procedure does not change from the corresponding CS Fallback handover procedures specified in TS 23.272 [6].

6.3.1.2.3 Impacted functions in the System

The MME provides priority indication to the eNodeB in S1 AP Initial Context Setup and UE Context Modification Request messages.

In a congestion situation the eNodeB should use priority indication to allocate E-UTRAN radio bearer resources preferentially compared to normal resource requests with no priority indication.

When CSFB based on PS handover is employed, the eNodeB provides priority indication to the target GERAN/UTRAN which in congestion situation, should allocate radio bearer resources with preference over normal resource requests with no priority indication.

6.3.1.3 Key Issue 3 - Priority handling of mobile originating call

6.3.1.3.1 Description

In Rel-9 GERAN/UTRAN CS Fallback procedure for mobile originating call, it is not clear how the MME determines whether an originating call needs priority handling. This is a necessary function for the MME as it needs to send the request message to the eNodeB to request the radio resource allocation in E-UTRAN if UE is in Idle mode and/or for the eNodeB to forward the priority indication to the RNC for radio resource allocation if PS handover is supported (see clause 6.3.1.2: Key Issue2 - Priority radio resource handling in CS fallback).

In case of emergency call, TS 23.272 [6] specifies as follows, so that MME can determine the call requires priority and informs E-UTRAN to allocate the radio resource in prioritized way,

In TS 23.272 [6], clause 4.6:

When UE is performing CS fallback procedure for Mobile Originating Call for the purpose of emergency call, it shall indicate to the MME that this CS fallback request is for emergency purpose. MME also indicates to the E-UTRAN via the appropriate S1-AP message that this CS fallback procedure is for emergency purpose.

In addition, PS handover priority handling for emergency call is also specified in TS 25.413 [5] where priority indication is forwarded from source RAT to the target RAT.

For MPS-subscribed UEs, the similar mechanisms for emergency call need to be specified for priority call handling.

6.3.1.3.2 Solution

6.3.1.3.2.1 Mobile Originating call - PS HO supported

The solution for priority handling of originating call is illustrated in Figure 6.3.1.3-1. The priority handling in this call flow applies to both cases of UE in Idle mode and Active mode.

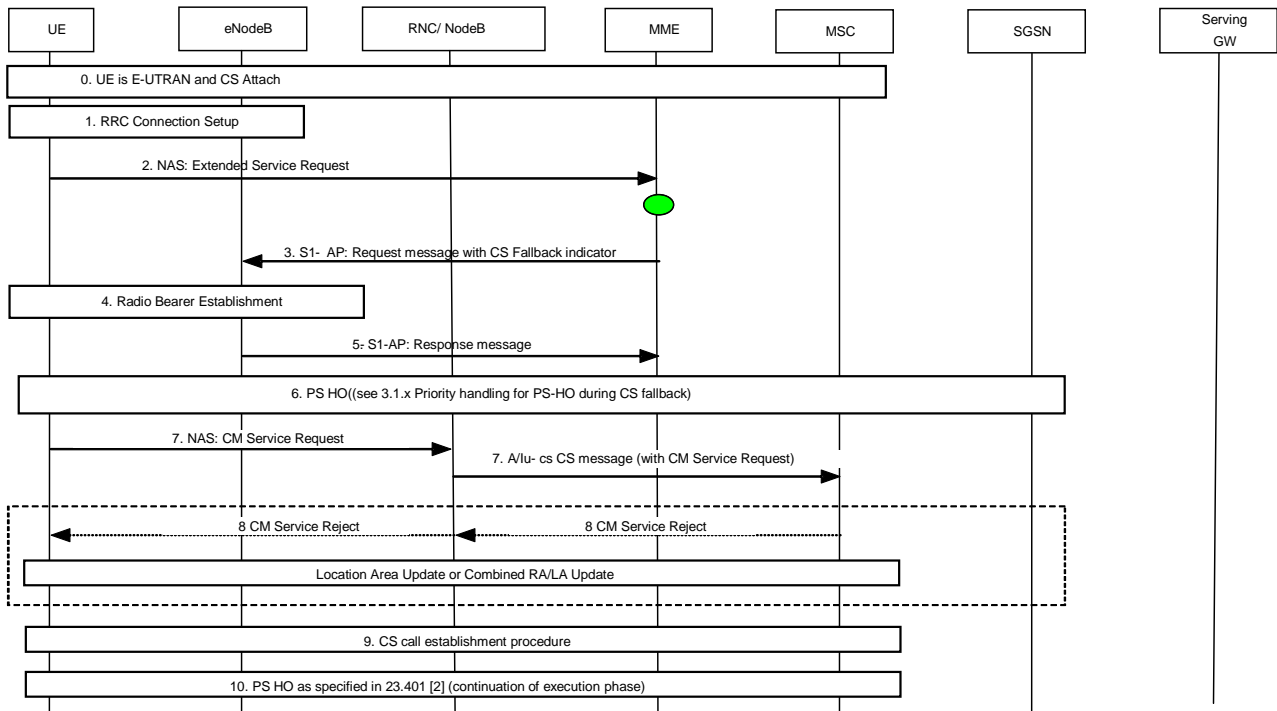

Figure 6.3.1.3-1: Priority handling of CS Fallback for Mobile Originating Call in idle mode

- 0) During the E-UTRAN attach procedure the subscription information downloaded from the HSS contains CS priority indication if the user has subscribed the eMLPP priority service in the CS domain.
- 1) This step is performed if UE is in Idle mode, and UE sets the establishment cause to HighPriorityAccess based on Access Class information, i.e. UE is subscribed to one of 11 to 15 in order to ensure that the RRC connection is treated with adequate priority (see TS 36.331 [7]).
- 2) UE sends the Extended Service Request to MME. This message is transported by S1-AP message which has establishment cause "HighPriorityAccess" from eNodeB if Step1 is performed.

In this step, UE may get the lower layer failure due to radio congestion and in this case, UE reselects the 2G/3G radio and establish the CS call as specified in TS 24.301 [11]. Otherwise, if UE receives Extended Service Reject from MME in response to step 2 due to, for instance, network congestion, UE reselects the 2G/3G radio and establishes the CS call as well as specified in TS 24.301 [11].

NOTE 1: Based on operator policy, MME may decide whether to initiate CS Fallback taking other ongoing service(s), e.g. LCS over LTE, into account.

MME determines the CS Fallback procedure needs priority handling and sends S1-AP Request message to the eNodeB with CS Fallback indicator and priority indication. In case Step 1 was performed, the MME determines that the Extended Service Request required priority handling based on either the "HighPriorityAccess" establishment cause sent by eNB to the MME in the S1AP message, i.e. in case Step 1 was performed or the CS priority Indication if "HighPriorityAccess" establishment cause has not been received, i.e. in case step 1 was not performed.

According to operator policy the MME may use CS priority Indication to verify the priority handling of the CS Fallback procedure, in the case "HighPriorityAccess" is received in the S1-AP message.

NOTE 2: The priority indication shall be able to set a different priority level from the one for the emergency call triggered CS fallback.

From Step 3 to 6, procedure described in clause 6.3.1.2.2 of this TR is applied.

From Step 7 to step 10, there is no change from the corresponding CS Fallback procedures specified in TS 23.272 [6].

Related procedure for Attach is described in Figure 6.3.1.3-2.

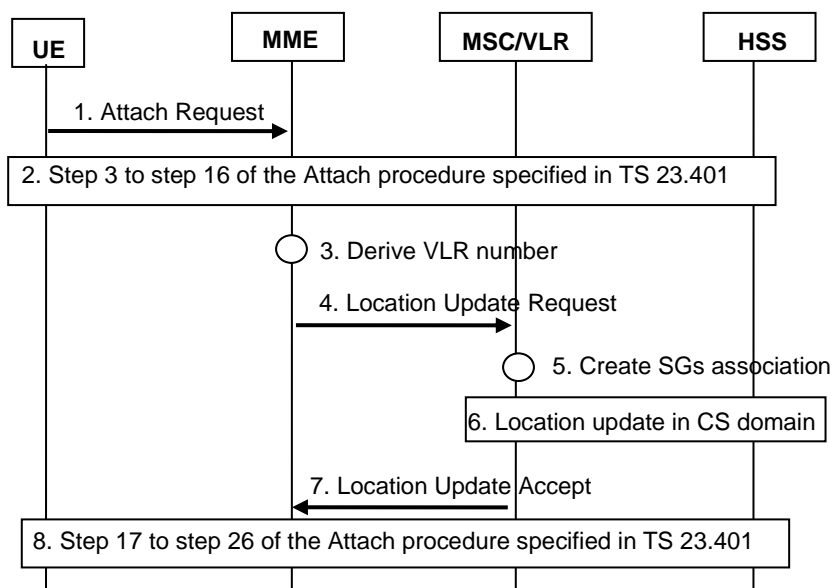

Figure 6.3.1.3-2: Attach procedure for priority handling of CS Fallback

- 1)-6) Step 1-6 are performed as defined in TS 23.272 [6]. If the UE has subscribed the eMLPP service in the CS domain, MME get the CS priority indication in the subscription data from the HSS via the Update Location Ack (IMSI, Subscription data) message. The CS priority indication is derived from the eMLPP Service Subscription.
- 7) The VLR responds with Location Update Accept (VLR TMSI) to the MME.

6.3.1.3.3 Impacted functions in the System

The HSS provides the CS priority indication to the MME during the subscription data update procedure if the user subscribes the eMLPP service in the CS domain. MME determines whether the CSFB MO procedure needs to be handled preferentially based on that indication.

The MME provides priority indication in S1 AP Initial Context Setup and UE Context Modification Request messages to the eNodeB.

In a congestion situation, the eNodeB should use priority indication to allocate E-UTRAN radio bearer resources with preference over normal resource requests with no priority indication.

6.3.2 CS Fallback to 1xRTT

6.3.2.1 Key Issue1 - Procedure Flow for Priority handling of mobile terminating call

6.3.2.1.1 Description

In Rel-9 1x CS Fallback procedure for mobile terminating call originated by the Service User, following issues needs to be resolved.

1. There is no mechanism for MME to prioritize the handling of Paging Request with priority indication arrived from MSC.
2. There is no mechanism for eNodeB to page the terminating UE and allow it to establish the AS and NAS signalling connection for subsequent CS Fallback procedure in prioritized way.

Due to lack of above capabilities, there is a case where the CS Fallback procedure triggered by the call arrival from a Service User cannot be completed successfully under network congestion situation, e.g. MME and eNodeB congestions. Therefore, when MME detects the CS Fallback requires the priority handling, it shall be possible for the MME and eNodeB to handle the CS Fallback related procedure preferentially compared to other normal transactions as well as to page the UE and enable the terminating UE to establish the AS and NAS signalling connections.

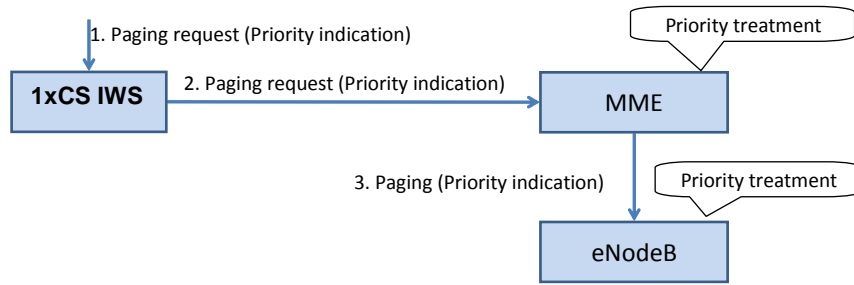

Figure 6.3.2.1.1: Capability required for mobile terminating call originated by a Service User

6.3.2.1.2 Solution

The solution for priority handling of terminating call is illustrated in Figure 6.3.2.1.2-1.

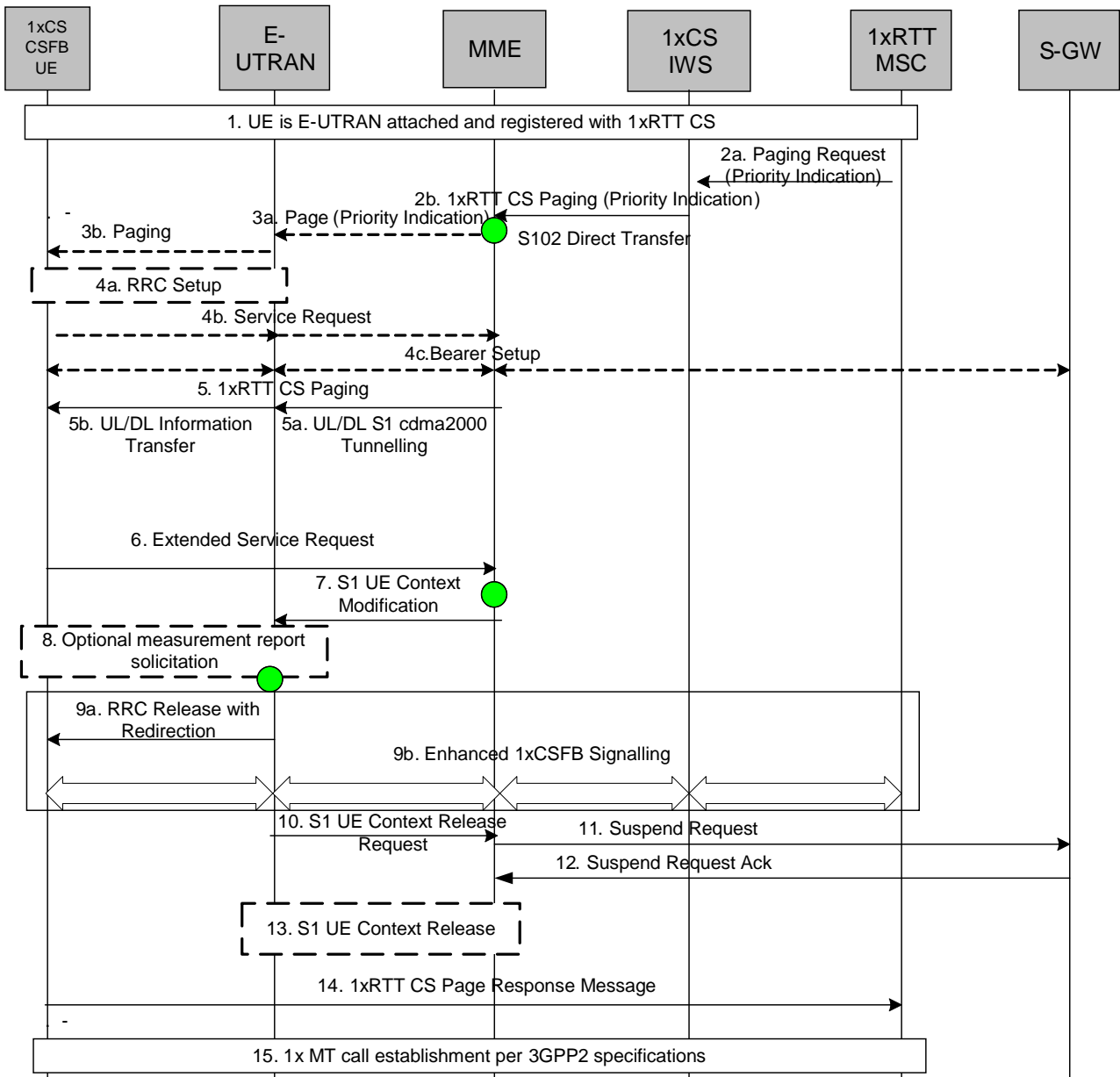

Figure 6.3.2.1.2-1: MT call to a 1x CS user in E-UTRAN

The key modifications to the basic flow for providing MPS service are:

1. Same as in 1xCSFB.
 - 2a. The paging request message from the 1xRTT MSC to the IWS will contain a priority value or an emergency indicator as specified in 3GPP2 specification A.S0008-C v3.0 [9] / A.S0009-C v3.0 [10].
 - 2b. The S102 message containing the paging request message sent from the 1xCS IWS to the MME contains a priority value.
 - 3a. Based on the priority field or an emergency indicator in S102 message, if the UE is idle, the MME indicates priority handling to the eNB for the page message.
 - 3b. The eNB handles the page message in a priority manner.
 - 4a. The UE and the eNB setup RRC connection.
- Steps 4b through 6 occur as specified in TS 23.272 [6].
6. When MME receives Extended Service Request in Step 6, it detects this message is the response to the priority CS Fallback procedure initiated in step 3, and the MME processes this message with priority.
7. The MME sends S1AP UE Context Modification with CSFB indication and a priority indication.

Steps 8 through 15 occur as specified in TS 23.272 [6]. Either Step 9a occurs in case basic 1xCSFB and Step 9b occur for enhanced 1xCSFB.

Steps 8 and 9 are handled with priority by the eNB.

6.3.2.1.3 Impacted functions in the System

The MME receives a S102 message which includes 1xRTT CS Paging with priority indication.

In a congestion situation the MME should use this priority indication to process this message and also the subsequent CS fallback procedure preferentially compared to other normal transactions. For this purpose and for each paging attempt memorizes that the UE is paged with priority. The MME forwards the paging message with priority indication to the eNodeB.

In a congestion situation the eNodeB should handle received paging messages with priority indication with preference over normal paging messages.

6.3.2.2 Key Issue 2 – Procedure flow for Priority handling of mobile originated call

6.3.2.2.1 Description

Flows for priority handling of mobile originated call.

6.3.2.2.2 Solution

The solution for priority handling of originating call is illustrated in Figure 6.3.2.2.2-1.

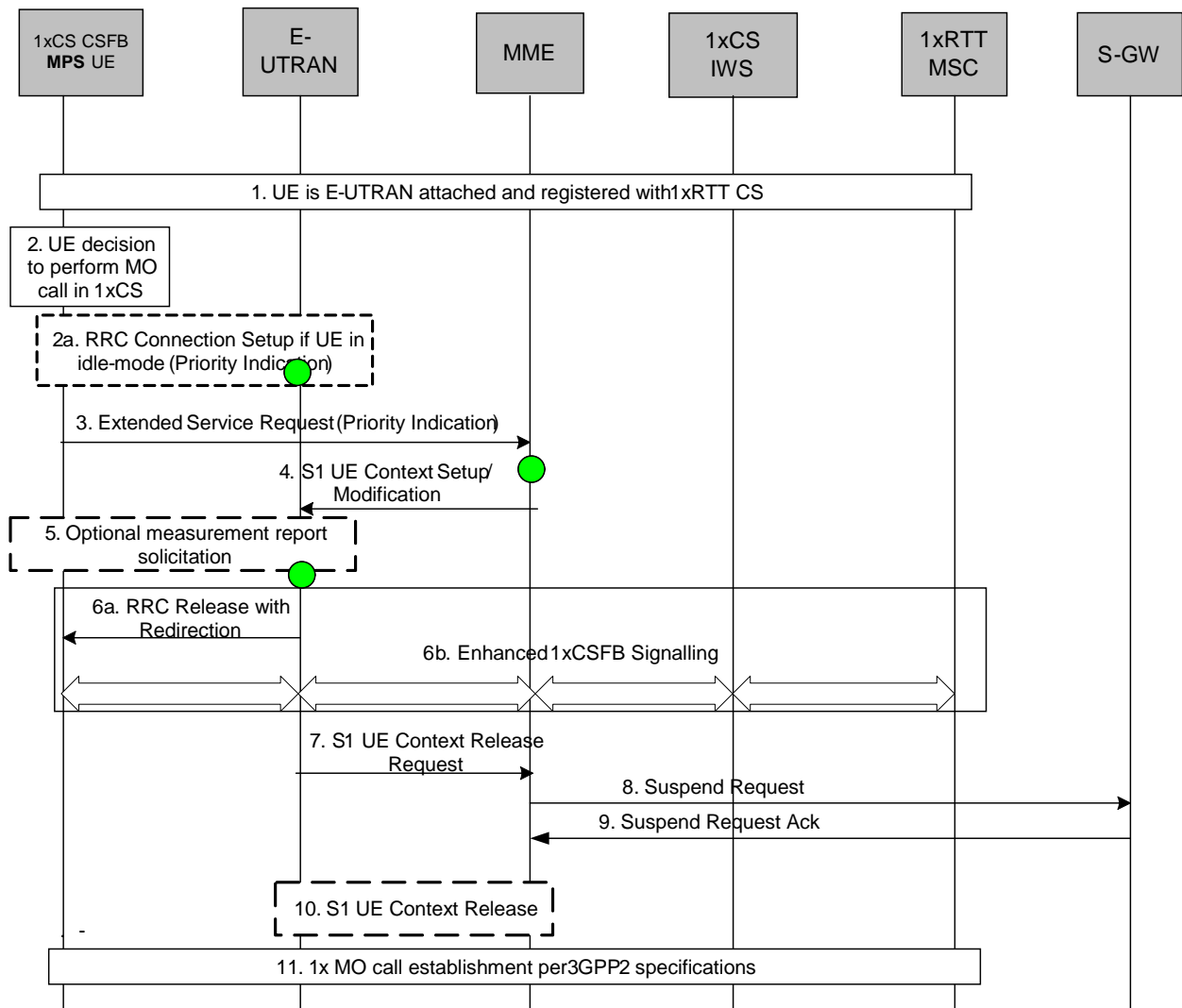

Figure 6.3.2.2.2-1: CS MO call using fallback to CDMA 1x RTT network by a Service user

The key modifications to the basic flow for providing MPS service are:

1. During the E-UTRAN attach procedure the subscription information downloaded from the HSS contains the CS priority indication if the user is a service user.
- 2a. If the UE is in idle-mode, in order to ensure that the RRC connection is treated with adequate priority the UE sets the establishment cause to HighPriorityAccess.
3. The UE sends extended service request which does not contain any priority indication.
4. The MME determines that the Extended Service Request requires priority handling based on either (a) the "HighPriorityAccess" establishment cause sent by eNB to the MME in the S1AP message if the MO 1xCSFB call occurred when the UE is in idle-mode, or (b) the CS priority indication in subscription information sent by the HSS during the attach procedure if MO 1xCSFB call occurred when the UE is in connected state. The MME sends an S1 UE Context modification (for an active UE) or, UE Context setup (for an idle UE). This message also includes a priority indication.

According to operator policy the MME may use the CS priority indication to verify the priority handling of the CS Fallback procedure, in the case "HighPriorityAccess" is received in the S1-AP message.

Steps 5 through 11 occur as specified in TS 23.272 [6]. Either Step 6a occurs in case basic 1xCSFB and Step 6b occur for enhanced 1xCSFB.

Steps 5 and 6 are handled with priority by the eNB and does not execute concurrent PS handover to CDMA eHRPD access.

6.3.2.3 Impacted functions in the System

The HSS provides the CS priority indication to the MME during the subscription data update procedure if the user subscribes the 1xCS priority service in the CS domain. MME determines whether the CSFB MO procedure needs to be handled preferentially based on that indication.

The MME provides priority indication in S1 AP Initial Context Setup and UE Context Modification Request messages to the eNodeB.

In a congestion situation, the eNodeB uses priority indications to allocate E-UTRAN radio bearer resources with preference over to normal resource requests with no priority indication.

7 Overall Solution

Editor's Note: This clause will capture the overall solution (e.g. information storage, call flows, impacts to NE, etc.).

7.1 IMS Multimedia Priority Services

7.2 Priority EPS Bearer Service

7.3 CS Fallback

8 Conclusions

This Technical Report has served its purpose in providing analysis and solutions in order to support Multimedia Priority Services for E-UTRAN access within Rel-10.

Based on the analysis provided in the main body of this TR, SA2 can undertake the normative work towards the specifications under its responsibility.

The potential impacted stage 2 specifications under SA2 responsibility are as follows (list is not exhaustive):

- TS 23.401 [3]
- TS 23.203 [15]
- TS 23.228 [12]
- TS 23.272 [6]
- TS 23.002 [4]/TS 23.221 [20] (if needed)

And based on the analysis provided in clause 6.1.5 Priority resource handling in SRVCC, SA WG2 can undertake the normative work towards the Rel-11 specifications under its responsibility.

The potential impacted stage 2 specifications under SA WG2 responsibility are as follows (list is not exhaustive):

- TS 23.216 [16]

- TS 23.237 [19]

No special mechanisms and hence no standards impacts are required to support priority resource handling for SRVCC to 1xCS.

Annex A: Change history

:Change history							
Date	TSG #	TSG Doc.	CR	Rev	Subject/Comment	Old	New
2010-09	SP-49	SP-100559	-	-	MCC Update for presentation to TSG SA for information	0.5.0	1.0.0
2011-06	SP-52	SP-110354	-	-	MCC update for presentation to TSG SA for approval	1.4.0	2.0.0
2011-06	SP-52	-	-	-	MCC update to version 11.0.0 for publication after TSG SA approval	2.0.0	11.0.0