

# 3GPP TR 23.825 V1.4.0 (2004-01)

---

*Technical Report*

## **3rd Generation Partnership Project; Technical Specification Group Services and System Aspects; Overall Architecture Aspects of IP Flow Based Bearer Level Charging; Stage 2 (Release 6)**



The present document has been developed within the 3<sup>rd</sup> Generation Partnership Project (3GPP™) and may be further elaborated for the purposes of 3GPP.

The present document has not been subject to any approval process by the 3GPP Organizational Partners and shall not be implemented. This Specification is provided for future development work within 3GPP only. The Organizational Partners accept no liability for any use of this Specification. Specifications and reports for implementation of the 3GPP™ system should be obtained via the 3GPP Organizational Partners' Publications Offices.

---



*Remove GSM logo from the cover page for pure 3<sup>rd</sup> Generation documents.*

*Select keywords from list provided in specs database.*

Keywords

---

<keyword[, keyword]>

**3GPP**

Postal address

---

3GPP support office address

---

650 Route des Lucioles - Sophia Antipolis  
Valbonne - FRANCE  
Tel.: +33 4 92 94 42 00 Fax: +33 4 93 65 47 16

Internet

---

<http://www.3gpp.org>

---

**Copyright Notification**

No part may be reproduced except as authorized by written permission.  
The copyright and the foregoing restriction extend to reproduction in all media.

© 2002, 3GPP Organizational Partners (ARIB, CWTS, ETSI, T1, TTA, TTC).  
All rights reserved.

# Contents

Foreword .....	6
Introduction .....	6
1 Scope .....	7
2 References.....	7
3 Definitions, symbols and abbreviations .....	7
3.1 Definitions.....	7
3.2 Symbols .....	8
3.3 Abbreviations .....	8
4 General Charging Architecture Requirements .....	9
4.1 General.....	9
4.2 Traffic Plane Function .....	9
4.3 Charging rules .....	10
4.3.1 Termination Action.....	11
4.3.2 Credit management .....	12
4.4 Reporting .....	12
4.5 Backwards compatibility .....	12
4.6 Charging models .....	13
4.6.1 General .....	13
4.6.2 Examples of Service Data Flow Charging .....	13
5 Architectural Concept.....	14
5.1 Architecture and Reference Points.....	14
5.1.1 Online service data flow-based bearer charging architecture .....	14
5.1.2 Offline service data flow-based bearer charging architecture .....	14
5.2 Functional Entities .....	15
5.2.1 Service Data Flow Based Charging Rules Function .....	15
5.2.2 Service Data Flow Based Credit Control Function .....	15
5.2.3 Charging Collection Function .....	16
5.2.4 Traffic Plane Function .....	16
5.2.5 Application Function .....	16
5.3 Reference points.....	17
5.3.1 New Reference points.....	17
5.3.2 Existing reference points.....	19
5.3.3 Rx/Gx functions and SBLP usage.....	19
6 Message Flows .....	19
6.1 Bearer Service Establishment .....	19
6.2 Bearer Service Modification .....	20
6.3 Bearer Service Termination .....	21
6.4 Provision of Charging Rules triggered by other event to the CRF .....	22
Annex A: Overall architectural impacts of IP flow based charging .....	23
A.1 GGSN in HPLMN .....	23
A.2 Comparison of S-CDR and G-CDR fields .....	23
A.2.1 S-CDR information missing from G-CDR .....	23
A.2.2 Served IMEI .....	23
A.2.3 MS Network Capability .....	23
A.2.4 LA C/RAC/CI at “record opening” .....	24
A.2.5 Access Point Name Operator Identifier .....	24
A.2.6 System Type.....	24
A.2.7 CAMEL information.....	25
A.2.8 RNC unsent data volume .....	25
A.3 RADIUS attributes .....	25

Annex B: IMS and Flow based Charging .....25  
B.1 IMS SIP signalling .....26  
Annex C: Change history .....26

---

## Foreword

This Technical Report has been produced by the 3<sup>rd</sup> Generation Partnership Project (3GPP).

The contents of the present document are subject to continuing work within the TSG and may change following formal TSG approval. Should the TSG modify the contents of the present document, it will be re-released by the TSG with an identifying change of release date and an increase in version number as follows:

Version x.y.z

where:

- x the first digit:
  - 1 presented to TSG for information;
  - 2 presented to TSG for approval;
  - 3 or greater indicates TSG approved document under change control.
- y the second digit is incremented for all changes of substance, i.e. technical enhancements, corrections, updates, etc.
- z the third digit is incremented when editorial only changes have been incorporated in the document.

---

## Introduction

*This clause is optional. If it exists, it is always the second unnumbered clause.*

---

# 1 Scope

The present document identifies the overall architecture aspects of IP flow based bearer level charging.

It is expected that the content of this TR will act as a basis for:

- Change requests against the architecture specifications [5] of SA2, clarifying the architecture implications of IP flow based bearer charging
- Change requests against the Charging Principles specification [3] of SA5, which contains the charging architecture and mechanisms.

---

# 2 References

The following documents contain provisions which, through reference in this text, constitute provisions of the present document.

- References are either specific (identified by date of publication, edition number, version number, etc.) or non-specific.
- For a specific reference, subsequent revisions do not apply.
- For a non-specific reference, the latest version applies. In the case of a reference to a 3GPP document (including a GSM document), a non-specific reference implicitly refers to the latest version of that document *in the same Release as the present document*.

- [1] 3GPP TR 41.001: "GSM Release specifications".
- [2] 3GPP TS 21.905: "Vocabulary for 3GPP Specifications".
- [3] 3GPP TS 32.200: "Charging Principles".
- [4] 3GPP TS 23.228: "IP Multimedia (IM) Subsystem - Stage 2".
- [5] 3GPP TS 23.002: "Network architecture".
- [6] 3GPP TS 23.060: "General Packet Radio Service (GPRS); Service description; Stage 2".
- [7] 3GPP TS 32.225: "Telecommunication management; Charging management; Charging data description for the IP Multimedia Subsystem (IMS)".

---

# 3 Definitions, symbols and abbreviations

## 3.1 Definitions

For the purposes of the present document, the terms and definitions given in TS 21.905 [2] and in TS 32.225 [7] and the following apply:

**Editor's note:** terms shown in <angle brackets> are provisional.

**Packet flow:** a specific user data flow carried through the Traffic Plane Function. A packet flow can be an IP flow.

**Service data flow:** aggregate set of packet flows.

In the case of GPRS, it shall be possible that a service data flow is more granular than a PDP context.

**Service Data Flow Filter:** a set of filter parameters used to identify one or more of the packet flows constituting a service data flow. At least the following means for the packet flow identification shall be supported: source and destination IP address+port, transport protocol, or application protocol.

**Charging rule:** a set of information comprising the service data flow filters, charging key, and the associated charging actions, for a single service data flow (further details can be found in 4.3).

**Charging key:** information used by the online and offline charging system for rating purposes.

**Dynamic charging rules:** Charging rules where some of the data within the charging rule (e.g. service data flow filter information) is assigned via real-time analysis which may use dynamic application derived criteria.

**Static charging rules:** Charging rules where all of the data within the charging rule describing the service data flow is permanently configured throughout the duration of a user's data session. Static charging rules may be activated dynamically.

**Predefined charging rules:** Static charging rules which are defined in the Traffic Plane Function.

## 3.2 Symbols

For the purposes of the present document, the following symbols apply:

<symbol>      <Explanation>

## 3.3 Abbreviations

For the purposes of the present document, the following abbreviations apply:

AF	Application Function
BS	Billing System
CCF	Charging Collection Function
CDR	Charging Data Records
CGF	Charging Gateway Function
CRF	Charging Rules Function
CSCF	Call Session Control Function
ECF	Event Charging Function
GCID	GPRS Charging ID
GGSN	Gateway GPRS Support Node
GPRS	General Packet Radio Service
HPLMN	Home PLMN
HTTP	Hypertext Transfer Protocol
ICID	IMS Charging Identifier
IM	IP Multimedia
IM CN SS	IP Multimedia Core Network Subsystem
IMS	IP Multimedia Core Network Subsystem
IMSI	International Mobile Subscriber Identity
OCS	Online Charging System
P-CSCF	Proxy-CSCF
PDGw	Packet Data Gateway
PLMN	Public Land Mobile Network
PSTN	Public Switched Telephone Network
QoS	Quality of Service
S-CSCF	Serving-CSCF
SGSN	Serving GPRS Support Node
SIP	Session Initiation Protocol
TPF	Traffic Plane Function
UE	User Equipment
WAP	Wireless Application Protocol
WLAN	Wireless LAN



---

## 4 General Charging Architecture Requirements

*Editor's note: This clause is planned to contain the relevant architecture requirements related to IP flow level charging.*

### 4.1 General

The current level of traffic differentiation and traffic-type awareness of the GPRS architecture shall be extended beyond APN and PDP Context level. It shall be possible to apply differentiated charging for the traffic flows belonging to different services (a.k.a. different service data flows) even if they use the same PDP Context.

Charging and tariffing models described in this Technical Report shall be possible to be applied to both prepaid and postpaid subscribers, i.e. to both online and offline charging.

Online and offline are not the same as prepaid and postpaid (see TS 32.225 [7]). For example it is worth highlighting that the operator can have postpaid subscribers on credit control by using on-line charging mechanisms.

The GPRS online charging solutions up to release 5 are built around CAMEL mechanisms that provide online access - and charging-control for GPRS - pertaining to PDP Contexts of an APN.

The evolved bearer charging architecture developed in this Technical Report shall use generic native IP charging mechanisms to the extent possible in order to enable the reuse of the same charging solution and infrastructure for different type of IP-Connectivity Networks.

**Note:** Providing differentiated service-data flow-based charging is a different function from providing differentiated traffic treatment on the IP-flow level. The operation of service-data flow-based charging shall not mandate the operation of service-based local policy.

The following new release 6 functions need to be provided by the network for service data flow based charging. This applies to both online and offline charging unless otherwise specified:

- Identification of the service data flows that need to be charged individually (e.g. at different rates)
- Provision and control of charging rules on service data flow level
- Reporting of service data flow level byte counts
- Event indication according to on-line charging procedures (e.g. sending AAA Accounting Stop) and, optionally, following this particular event, taking appropriate actions on service data flow(s) according to the termination action defined in the respective charging rule(s).

These new functions shall be compatible and coherent with the authentication, authorization, PDP context management, roaming and other functions provided by the existing architecture.

In addition charging based on specific application services or protocols shall be supported.

### 4.2 Traffic Plane Function

This section refers to the filtering that identifies the service data flows that need to be charged individually (e.g. at different rates). Basic example: look for packets of one service, e.g. to and from a server A.

- Different filtering and counting shall be supported for downlink and uplink.
- Different granularity for service data flow filters identifying the service data flow shall be possible e.g.
  - Filters based on the IP 5 tuple (source IP address, destination IP address, source port number, destination port number, protocol ID of the protocol above IP).. Port numbers and protocol ID may be wildcarded. IP addresses may be wildcarded or masked by a prefix mask.

- Special filters which look further into the packet, or require other complex operation (e.g. maintaining state) may be pre-defined in the TPF and invoked by the CRF using standardised means. Such filters may be used to support filtering with respect to a service data flow based on the transport and application protocols used above IP. This shall be possible for HTTP and WAP. This includes the ability to differentiate between TCP, Wireless-TCP according to WAP 2.0, WDP, etc, in addition to differentiation at the application level. Filtering for further application protocols and services may also be supported.
- In the case of GPRS, the traffic plane function shall provide the ability to support simultaneous independent filtering on service data flows associated with all, and each individual active PDP contexts; that is, primary and secondary PDP contexts, of one APN.
- In case of no applicable filters for a service data flow, an operator configurable default charging should be applied.
- In case of GPRS, the TPF is a logical function allocated to the GGSN.

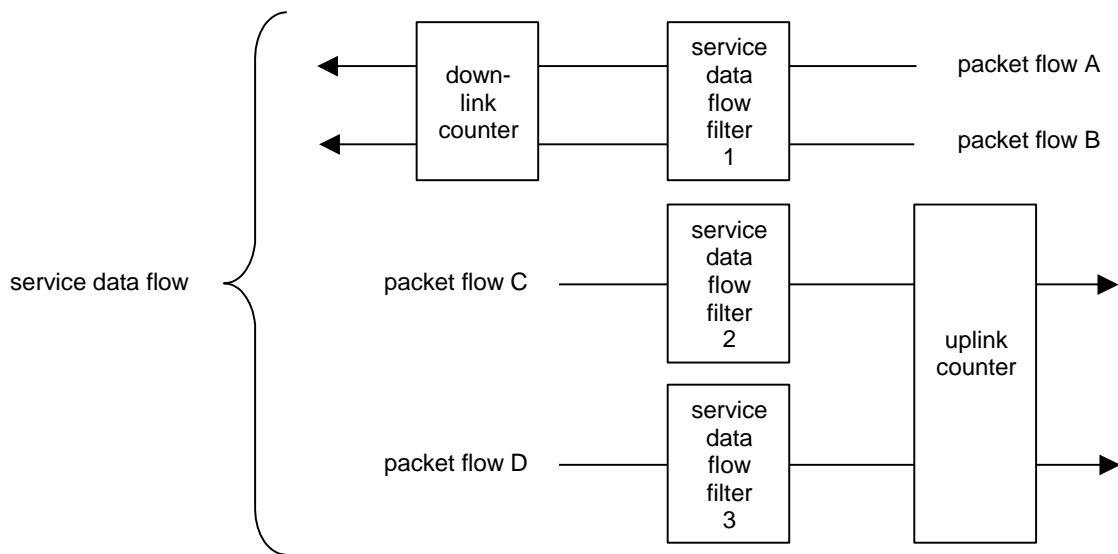

**Figure 4.2 – Relationship of service data flow, packet flow and service data flow filter**

## 4.3 Charging rules

Charging rules contain information that allow for filtering of traffic to identify the packets belonging to a particular service data flow, and allow for defining how the service data flow is to be charged. The following apply to charging rules:

- Charging rules for bearer charging shall be defined by the operator.
- These charging rules shall be made available to the Traffic Plane function for both offline and online charging.
- Multiple charging rules shall be supported simultaneously per user.
- Filtering information within a charging rule is applied through filtering functionality at the Traffic Plane Function to identify the packets belonging to a particular service data flow.
- Charging rules with dynamically provisioned filtering information (i.e. made available to the Traffic Plane Function) shall be supported in order to cover IP service scenarios where the filtering information is dynamically negotiated (e.g. negotiated on the application level (e.g. IMS)).
- Pre-defined charging rules shall be supported.

- Elements of charging rules may be statically configured at the Traffic Plane Function, or dynamically provisioned.

Note: The mechanism to support use of elements statically pre-defined in the TPF (e.g. filter information) is for stage 3 development.

Note: The stage 3 development may also evaluate providing an optimisation to support dynamic provisioning of an entire charging rule pre-defined in the TPF.

- Pre-defined filters may support extended capabilities, including enhanced capabilities to identify packets associated with application protocols.
- There may be overlap between the charging rules that are applicable. Overlap can occur between:
  - multiple pre-defined charging rules in the TPF
  - charging rules pre-defined in the TPF and rules from the Service Data Flow Based Charging Rules Function, which can overlay the pre-defined rules in the TPF

The precedence identified with each charging rule shall resolve all overlap between the charging rules. When overlap occurs between a dynamically allocated charging rule and a pre-defined charging rule at the TPF, and they both share the same precedence, then the dynamically allocated charging rule shall be used.

- Charging rules contain information on
  - How a particular service data flow is to be charged: online/offline
  - In case of offline charging whether to record volume- or time-based charging information
  - In case of online charging, what termination action is to be applied
  - Charging key
  - Service data flow filter(s)
  - Precedence
- Once the charging rule is determined it is applied to the service data flow at the Traffic Plane Function and packets are counted and categorised per the rule set in the charging rule.
- Different charging rules shall be supported in downlink and uplink.
- Charging rules shall be available for both user initiated and network initiated flows.
- Charging rules can change and be overridden, e.g. for a previously established PDP context in the GPRS case, based on specific events (e.g. IM domain events or GPRS domain events, credit control events).
- It shall be possible to apply different charging rules for different users or groups of users.
- It shall be possible to apply different charging rules based on the location of the user (e.g. based on identity of the roamed to network).
- For GPRS, charging rule assignment shall be possible at PDP context establishment and modification.
- For GPRS, it shall be possible to have different charging rules depending on the APN used.

### 4.3.1 Termination Action

The Termination Action applies only in case of online charging. Each charging rule has a corresponding termination action defined. The termination action indicates the action which the Traffic Plane Function should perform when the online charging system causes the TPF (Diameter Credit Control Client) to terminate a service data flow.

Termination Actions may also be defined in the OCS and conveyed to the CRF via mechanisms defined for the Rx interface or conveyed to the TPF via the Gy interface.

**Editor's Note: It is FFS whether both mechanisms are necessary. The effects of different termination actions from the OCS and the CRF need to be studied.**

The defined termination actions include:

- Dropping the packets corresponding to a terminated service data flow as they pass through the Traffic Plane Function.
- A termination action may indicate to the TPF that a default termination action may be used according to operator's policy. For instance, a default behaviour may consist of allowing packets of the corresponding service data flow to pass through the TPF.

Additional termination actions such as re-directing packets corresponding to a terminated service data flow are to be investigated.

The Termination Action may trigger other procedures, e.g. the deactivation of a PDP context or the termination of a WLAN session.

### 4.3.2 Credit management

In case of online charging, it shall be possible to pool credit/resource limits for multiple charging rules applied at the Traffic Plane Function.

A pool of credit/resource shall also allow to have individual credit/resource limits for an individual charging rule applied at the Traffic Plane Function. Multiple pools of credit/resource shall be allowed per user.

Rating decisions shall be strictly controlled by the OCS for each service. The OCS shall also control the credit pooling decision for charging rules. The OCS shall either provide a new pool of credit/resource together with new credit/resource limits or a reference to a pool of credit/resource that already exists at the TPF.

Note: 'credit' as used here does not imply actual monetary credit, but an abstract measure of resources available to the user. The relationship between this abstract measure, actual money, and actual network resources or data transfer, is controlled by the OCS.

## 4.4 Reporting

This refers to the differentiated charging information being reported to the existing charging architecture. Basic example: those 20 packets were in rating category A, include this in your global charging information.

- The Traffic Plane function shall report bearer charging information for online
- The Traffic Plane function shall report bearer charging information for offline
- It shall be possible to collect charging information based on the bearer charging rules (service data flow related charging information), and in the case of GPRS, release 5 charging rules (per PDP context)
- It shall be possible to report charging information showing usage for each user for each charging rule, e.g. a report may contain multiple containers, each container associated with a charging key.
- It shall be possible to associate per PDP context charging information with the corresponding service data flow based charging information.

## 4.5 Backwards compatibility

The enhanced architecture shall be backwards compatible with release 5 charging capabilities.

## 4.6 Charging models

### 4.6.1 General

When developing the charging solutions, the following charging models should be considered, even though the full solution to support the models may not be within the scope of this TR.

Shared revenue services shall be supported. In this case settlement for all parties shall be supported, including the third parties that may have been involved providing the services.

The charging solution shall allow various charging models such as:

- Volume based charging
- Time based charging

Additional charging models that are event and service based require further investigation.

It shall be possible to restrict special rates to a specific service, e.g. allow the user to download a certain volume of data from one service for free, but this allowed volume is not transferable to other services. It shall be possible also to apply special rates based on the time of day.

It shall be possible to enforce per-service usage limits for a service data flow using online charging on a per user basis (may apply to pre-paid and postpaid users).

In the case of online charging, and where information is available to enable service data flow packets to be associated with a specific PDP context, it shall be possible to perform rating and allocate credit depending on the characteristics of the resources allocated initially (in the GPRS case, the QoS of the PDP context).

The flow based bearer level charging can support dynamic selection of charging to apply. A number of different inputs can be used in the decision to identify the specific charging to apply. For example, a service data flow may be charged with different rates depending on what QoS is applicable. The charging rate may thus be modified when a bearer is created or removed, to change the QoS provided for a service data flow.

The charging rate or charging model applicable to a service data flow may also be changed as a result of events in the service (e.g. insertion of a paid advertisement within a user requested media stream). The charging model applicable to a service data flow may also change as a result of events identified by the OCS (e.g. after having spent a certain amount, the user gets to use some services for free).

### 4.6.2 Examples of Service Data Flow Charging

There are many different services that may be used within a network, including both user-user and user-network services. Service data flows from these services may be identified and charged in many different ways. A number of examples of configuring charging rules for different service data flows are described below.

A network server provides an FTP service. The FTP server supports both the active (separate ports for control and data) and passive modes of operation. A charging rule is configured for the service data flows associated with the FTP server for the user. The charging rule uses a filter specification for the uplink that identifies packets sent to port 20 or 21 of the IP address of the server, and the origination information is wildcarded. In the downlink direction, the filter specification identifies packets sent from port 20 or 21 of the IP address of the server.

A network server provides a "web" service. A charging rule is configured for the service data flows associated with the HTTP server for the user. The charging rule uses a filter specification for the uplink that identifies packets sent to port 80 of the IP address of the server, and the origination information is wildcarded. In the downlink direction, the filter specification identifies packets sent from port 80 of the IP address of the server.

The same server also provides a WAP service. The server has multiple IP addresses, and the IP address of the WAP server is different from the IP address of the web server. The charging rule uses the same filter specification as for the web server, except the IP address is different.

An operator offers a zero rating for network provided DNS service. A charging rule is established setting all DNS traffic to/from the operators DNS servers as offline charged. The data flow filter identifies the DNS port number, and the source/destination address within the subnet range allocated to the operators network nodes.

An operator has a specific charging rate for user-user VoIP traffic over the IMS. A charging rule is established for this service data flow. The filter information to identify the specific service data flow for the user-user traffic is provided by the P-CSCF.

## 5 Architectural Concept

### 5.1 Architecture and Reference Points

*Editor's note: This clause is planned to contain the relevant part of the architecture impacted by IP flow level based charging.*

#### 5.1.1 Online service data flow-based bearer charging architecture

Figure 5.1 below presents the overall architecture for service data flow-based online bearer charging.

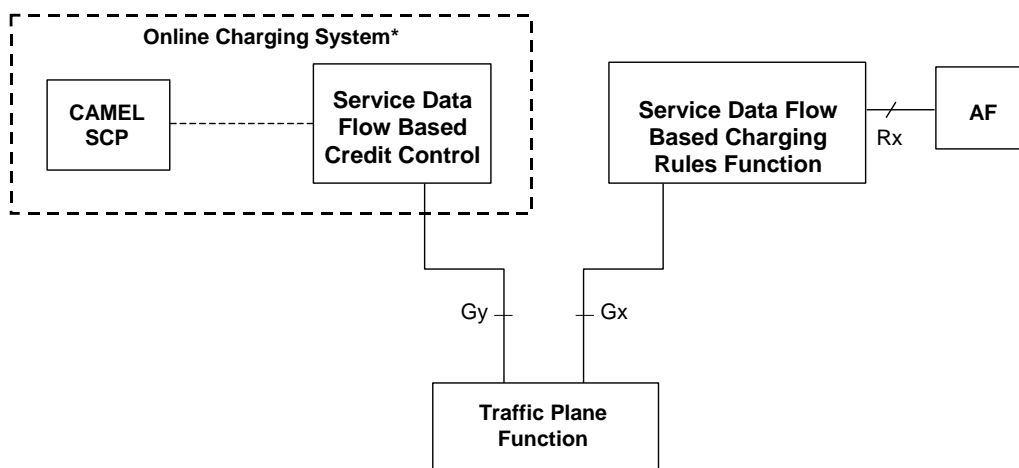

**Figure 5.1 – Overall architecture for service data flow based online bearer charging**

Note: No changes are foreseen on the CAMEL SCP.

Note(\*): The detailed functional entities of the On line Charging System are not shown in this figure. The details of the OCS are specified in TS 32.200, further internal details of the OCS for release 6 are expected to be specified by SA5.

The CAMEL-SCP depicted on the figure above performs the functions of the Rel-5 Bearer Charging Function defined in TS32.200.

#### 5.1.2 Offline service data flow-based bearer charging architecture

Figure 5.2 below presents the overall architecture for service data flow-based offline bearer charging.

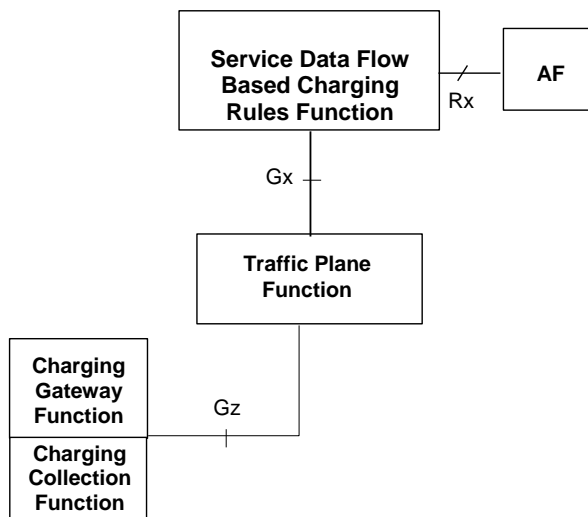

**Figure 5.2 – Overall architecture for service data flow based offline bearer charging**

Note: No changes are foreseen on the CCF.

## 5.2 Functional Entities

*Editor's note: This clause is planned to contain the description of new and modified functional entities.*

### 5.2.1 Service Data Flow Based Charging Rules Function

This entity provides service data flow level charging rules. This same functionality is required for both offline and online charging. The charging rules function accesses information stored in the service data flow based charging rules data repository. An external interface to the charging rules data repository may be used for management of the charging rules within the data repository. Specification of interfaces to the data repository is out of scope of this TR.

The service data flow based charging rules function supports both static and dynamic charging rules.

The service data flow based charging rules function determines what charging rules including precedence to apply for a user. The applicable charging rules are determined based on information, including that received from the Traffic Plane Function, i.e. information about the user, the bearer characteristics and whether it is an initial request or not. When a further request for charging rules from the Traffic Plane Function or information from an AF arrives the service data flow based charging rules function shall be able to identify whether new charging rules need to be transferred to the Traffic Plane Function and respond accordingly.

The service data flow based charging rules function will receive information from the application function that allows the service data flow to be identified, and this information may be used within the charging rule (i.e. protocol, IP addresses and port numbers). Other information that is received by the service data flow based charging rules function (i.e. application identifier, type of stream) may be used in order to select the charging rule to be applied.

### 5.2.2 Service Data Flow Based Credit Control Function

The Service Data Flow-Based Credit Control Function performs online credit control functions together with the Online Charging System. It provides a new function within the release 5 Online Charging System.

The Online Charging System is specified in 3GPP TS 32.200. The Service Data Flow Credit Control Function is considered as a new functional entity for release 6 within the Online Charging System.

The OCS can interact with the CRF, by using the mechanisms defined for the Rx interface. This allows the OCS to provide input to the charging rules selection by the CRF.

### 5.2.3 Charging Collection Function

The Charging Collection Function is specified in 3GPP TS 32.200.

The service data flow based charging requires no changes in the CCF.

### 5.2.4 Traffic Plane Function

The Traffic Plane Function shall be capable of differentiating user data traffic belonging to different service data flows for the purpose of collecting offline charging data and performing online credit control.

The Traffic Plane Function shall support pre-defined charging rules, and pre-defined filters. See section 4.2 for further requirements of the Traffic Plane Function.

For online charging, the Traffic Plane Function shall be capable of managing the aggregation of the credit/resource used for some or all of the service data flows of a user. The Traffic Plane Function shall also be capable of managing the credit/resource of each individual service data flow of the user.

For GPRS, it shall be possible to provide these functions for different service data flows even if they are carried in the same PDP Context. For GPRS, the traffic Plane Function is a logical function allocated to the GGSN.

**Editor's Note: The effects of this co-location to the interfaces still needs to be studied e.g. Gy, Gz, Gi. Gi radius extensions for charging purposes are not precluded.**

For GPRS, the TPF/GGSN shall be able to do separate counts per PDP context for a single service data flow if it is transferred on more than one PDP context. How this can be achieved is FFS.

For each PDP context, there will be a different OCS request/reporting, so this allows the OCS and offline charging system to apply different rating depending on the PDP context.

At initial bearer establishment the Traffic Plane Function shall request charging rules applicable for this bearer from the charging rules function. As part of the request, the Traffic Plane Function provides information on the user and the bearer characteristics to the charging rules function. The Traffic Plane Function shall use the charging rules received in the response from the charging rules function. In addition, the Traffic Plane Function shall use any applicable pre-defined static charging rules. Pre-defined charging rules may apply for all users or may be activated by the CRF.

If the bearer is modified by changing the bearer characteristics relevant for the selection of the charging rules, the Traffic Plane Function shall request charging rules for the new bearer characteristics from the charging rules function.

If the Traffic Plane Function receives an unsolicited update of the charging rules from the charging rules function, the new charging rules shall be used.

If another bearer is established by the same user (e.g. for GPRS a secondary PDP context), the same procedures shall be applied by the Traffic Plane Function as described for the initial bearer.

The Traffic Plane Function shall evaluate received packets against the service data flow filters in the order according to the precedence for the charging rules. When a packet is matched against a SDF filter, the packet matching process for that packet is complete, and the charging rule for that SDF filter shall be applied.

**Editor's Note: The relationship of the Traffic Plane Function and WLAN interworking nodes (e.g. WLAN PDGw) is FFS.**

### 5.2.5 Application Function

The application function provides information to the service data flow based charging rules function, which can then be used for selecting the appropriate charging rule, and also used for configuring some of the parameters for the charging rule. The operator configures the charging rules in the service data flow based charging rules function, and decides what data from the application function shall be used in the charging rule selection algorithm.

The Application Function shall provide information to allow the service data flow to be identified. The Application Function shall also provide some other information that may be used in the charging rule selection process.

The information provided by the application function is as follows:



- Information to identify the service data flow: refer to subclause 4.2  
The application function may use wildcards to identify an aggregate set of IP flows.
- Information to support charging rule selection:
  - Application identifier
  - Application event identifier
  - Type of Stream (e.g. audio, video) (optional)
  - Data rate of stream (optional)

**Editor's Note: Additional information is FFS.**

The "Application Identifier" is an identifier associated with each service that an AF provides for an operator (e.g. a PSS application function would have one application identifier for the PSS service).

The "Application event identifier" is an identifier within an Application identifier. It is used to notify the Service Data Flow Based Charging Rules Function of such a change within a service session that affects the charging rules, e.g. triggers the generation of a new charging rule.

## 5.3 Reference points

**Editor's note: This clause is planned to contain the description of new and modified reference points.**

### 5.3.1 New Reference points

#### 5.3.1.1 Gx reference point

The Gx reference point enables the use of service data flow based charging rules such as counting number of packets belonging to a rate category in the IP-Connectivity Network. This functionality is required for both offline and online charging.

Note: The reuse of existing protocols over the Gi reference point for Gx shall be evaluated in stage 3.

The Gx reference point supports the following functions:

1. Initialisation and maintenance of connection
2. Request for Charging Rules (from TPF to CRF)
3. Provision of Charging Rules (from CRF to TPF)
4. Indication of Bearer Termination (from TPF to CRF)

#### Initialisation and Maintenance of Connection

A single connection shall be established between a CRF and TPF pair. The connection can be direct, or established via a relay/proxy node. A connection may be redirected to an alternate node.

The relevant interworking peer nodes may be configured, or may be determined through a discovery mechanism. At a failover, commands which have not been successfully received shall be queued to the alternate peer.

The detail specification of the connection establishment and maintenance are for specification in stage 3.

#### Request for Charging Rules (from TPF to CRF)

At a bearer establishment/modification (PDP context establishment/modification for GPRS), the TPF requests the charging rules to be applied.

The request must identify whether it is an initial request (primary context establishment for GPRS), or a subsequent request (i.e. for GPRS, a secondary PDP context establishment, or a PDP context modification). For an initial request for GPRS, the request shall include APN, PDP address information, and at least one of IMSI or MSISDN.

An identifier is required to allow the specific instance in the TPF/CRF to be identified for subsequent data exchange. The identifier for the communication must be provided.

The request must provide further information used for the charging rule selection. The request must have an identifier for the bearer, the QoS information, and flow identifier information allocated to the bearer. For GPRS, this information would include the traffic class, and the TFT.

Where the charging rule selection data for a bearer is modified, the TPF sends the request to the CRF indicating it is for a bearer modification, and providing the modified data.

### **Provision of Charging Rules (from CRF to TPF)**

The CRF identifies the charging rules that are applicable to the TPF. The CRF then sends the charging rule information to the TPF to be installed.

Note: The stage 3 development shall support provisioning cases where:

- charging rules are to be installed in the TPF
- charging rules are to be removed in the TPF
- charging rules are to be installed and removed in the TPF
- charging rules are neither installed nor removed in the TPF (only relevant in the response to a request for charging rules)

The provisioning may be a response to a Request for Charging Rules, or it may be unsolicited.

The charging rule provision includes information about the instance it relates to (i.e. identifier for the relevant CRF/TPF instance), charging mechanism (online/offline), volume- or time-based charging indication, termination action, charging key, service data flow filter(s), and precedence.

The service data flow filters are specified separately for the uplink and downlink direction.

Note: A charging rule may provide information for service data flows for one direction, or for both directions.

### **Indication of Bearer Termination (from TPF to CRF)**

The TPF indicates to the CRF that a bearer is terminated.

The bearer termination indication includes information to identify the instance it relates to (i.e. an identifier for the relevant CRF/TPF instance), and an indication of the bearer being removed (the PDP context in the case of GPRS). The termination also indicates if this is the last bearer for that TPF/CRF instance.

#### **5.3.1.2 Gy reference point**

The Gy reference point allows credit control for service data flow based online charging. The functionalities required across the Gy reference point use functionalities and mechanisms specified for the release 5 Ro interface.

#### **5.3.1.3 Gz reference point**

The Gz interface enables transport of service data flow based offline charging information.

For GPRS the relationship of the Gz interface and the existing Ga interface is subject to investigation in SA5.

#### **5.3.1.4 Rx reference point**

The Rx reference point enables transport of information (e.g. dynamic media stream information) from the application function to the charging rules function. An example of such information would be filter information to identify the packet flow.

### 5.3.2 Existing reference points

The functionalities across the reference points described in this clause are not intended to be modified within the context of the concepts specified in this TR.

The Ro and Rf interfaces are specified for release 5 in TS 32.200 and TS 32.225.

The Ge interface is specified by TS 23.078 and TS 29.078.

### 5.3.3 Rx/Gx functions and SBLP usage

Dynamic media stream filter information for QoS policy and charging correlation may be provided to the GGSN via the Gq and Go interfaces. This is described in TS 23.207 and TR 23.917.

Dynamic and static media stream filter information for charging (data for the charging rules) may be provided to the Traffic Plane Function (GGSN in the case of GPRS) via the Rx and Gx interfaces. This is described in this TR.

These two functions are independent and thus can be provided separately.

## 6 Message Flows

*Editor's note: This clause is planned to contain the description of new and modified information flows.*

*Editor's Note: The flows below only cover the flows over the Gx interface. Interactions over the Rx interface are FFS.*

### 6.1 Bearer Service Establishment

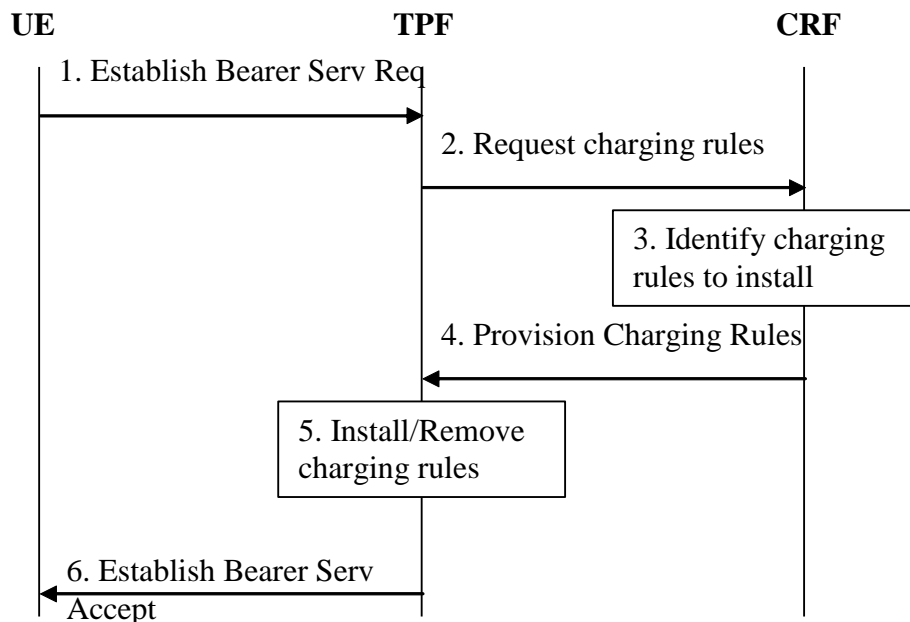

**Figure 6.1: Bearer Service Establishment**

1. The TPF receives a request to establish a bearer service. For GPRS, this is the GGSN that receives a Create PDP context request for a primary or secondary PDP context.

2. The TPF requests the applicable charging rules, and provides relevant input information for the charging rule decision.
3. The CRF determines the charging rules to be provisioned, based on information available to the CRF (e.g. information may be available from the AF and the new information received from the TPF). Charging rules may need to be added, and/or removed.
4. The CRF provides the charging rules to the TPF. This message is flagged as the response to the TPF request.
5. The TPF installs/removes the charging rules as indicated.
6. The TPF continues with the bearer service establishment procedure.

**Editor's Note:** It is FFS whether the bearer service establishment procedure can proceed in parallel with the charging rules request.

## 6.2 Bearer Service Modification

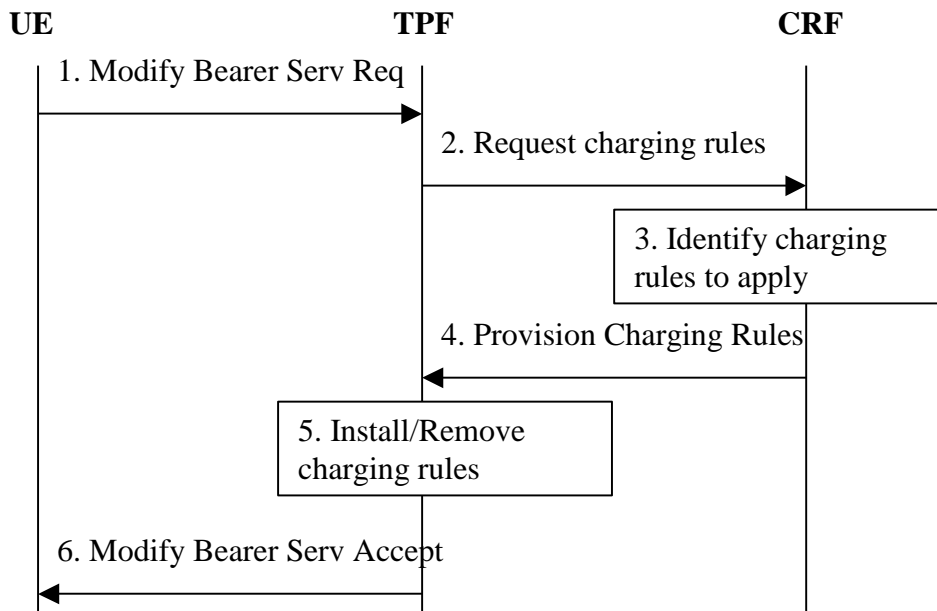

**Figure 6.2: Bearer Service Modification**

1. The TPF receives a request to modify a bearer service. For GPRS, the GGSN receives an Update PDP context request.
2. The TPF requests the applicable charging rules, and provides relevant input information for the charging rule decision.
3. The CRF determines the charging rules to be provisioned, based on information available to the CRF (e.g. information may be available from the AF and the new information received from the TPF) Charging rules may need to be added, and/or removed.
4. The CRF provides the charging rule information to the TPF. This message is flagged as the response to the TPF request.
5. The TPF installs/removes the charging rules as indicated.
6. The TPF continues with the bearer service modification procedure.

Note: In the case of GPRS, the modification of the bearer service may also be initiated by other nodes such as the SGSN.

Editor's Note: It is FFS whether the bearer service modification procedure can proceed in parallel with the charging rules request.

## 6.3 Bearer Service Termination

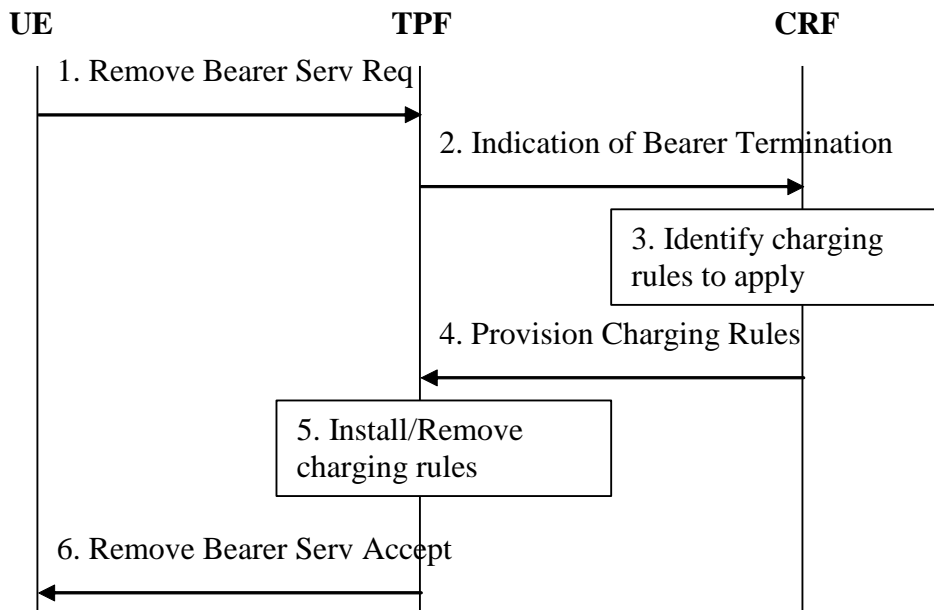

**Figure 6.3: Bearer Service Termination**

1. The TPF receives a request to remove a bearer service. For GPRS, this is the GGSN that receives a delete PDP context request.
2. The TPF indicates that a bearer (for GPRS, a PDP context) is being removed and provides relevant input information for the charging rule decision.
3. The CRF determines the charging rules to be provisioned, based on information available to the CRF (e.g. information may be available from the AF and the new information received from the TPF) Charging rules may need to be added, and/or removed.
4. The CRF provides the charging rule information to the TPF. This message is flagged as the response to the TPF request.
5. The TPF installs/removes the charging rules as indicated.
6. The TPF continues with the bearer service removal procedure.

Note: In the case of GPRS, the bearer service termination procedure may also be initiated by other nodes such as the SGSN.

Editor's Note: It is FFS whether the bearer service termination procedure can proceed in parallel with the indication of bearer termination.

## 6.4 Provision of Charging Rules triggered by other event to the CRF

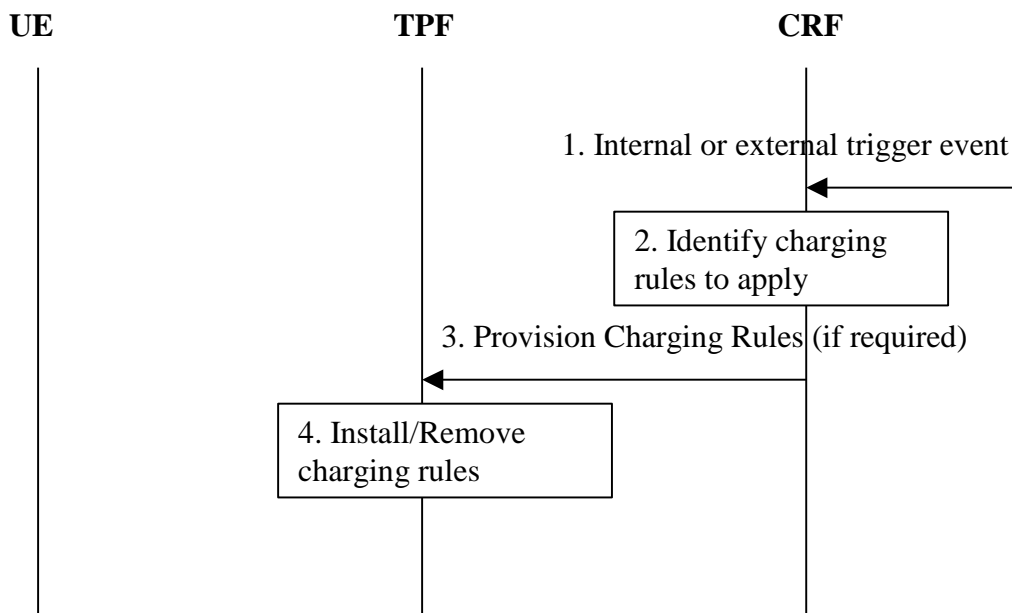

**Figure 6.4: Provision of Charging Rules due to external or internal Trigger Event**

1. The CRF receives a trigger event, with relevant information related to the event.
2. The CRF determines the charging rules to be added/removed, based on information available to the CRF (e.g. information may be available from the AF and the new information received from the trigger). Charging rules may need to be added, and/or removed.
3. If required, the CRF provisions the charging rules to the TPF.
4. The TPF installs/removes the charging rules as indicated.

---

## Annex A: Overall architectural impacts of IP flow based charging

### A.1 GGSN in HPLMN

One of the underlying drivers for the IP flow charging work is to permit greater flexibility in PS domain charging, and, to control this flexibility in the HPLMN. This is a fairly fundamental change from the concepts that lead to development of the CAMEL 3 standards (which provide the capability for pre-pay charging on the SGSN) and some aspects of the IMS architecture (e.g. P-CSCF and I-CSCF).

This movement towards charging in the “GGSN arena” rather than “charging at the SGSN” leads to a few questions:

- a) is all the information that the SGSN places on the S-CDR available at the GGSN? If not, what is missing, is it important, and, can GTP be upgraded to provide it to the GGSN?
- b) when this information is passed to the GGSN, can it then be made available as extra Radius parameters?
- c) does this information need to be sent on the Gx and/or Gy and/or Gz interfaces?

### A.2 Comparison of S-CDR and G-CDR fields

#### A.2.1 S-CDR information missing from G-CDR

The following fields are present in the S-CDR but absent from the G-CDR

- Served IMEI
- MS Network Capability
- LAC/RAC/CI at “record opening”
- Access Point Name Operator Identifier
- System Type
- CAMEL information
- RNC unsent data volume

These parameters are analysed further in the following subsections.

#### A.2.2 Served IMEI

This information is useful for many operational/statistical purposes within the HPLMN. Examples might include checking whether the SIM-IMEI combination “is correct”; which brands of mobile generate what proportion of revenue streams and/or access particular types of services; etc.

Hence it is recommended to provide the IMEISV to the GGSN for transparent transfer within the GGSN to the G-CDR and/or Radius attribute. This means the addition of an optional parameter to the Create PDP Context Request message.

Note that the IMEISV should be provided rather than just the IMEI because the SV information has some value, and, IMEISV is as equally easy for the SGSN to obtain as the IMEI.

#### A.2.3 MS Network Capability

This is the “core network” part of the mobile’s classmark. Review of 24.008 shows that most of the really interesting information for the HPLMN is contained within the Radio Classmark information and not within the MS Network Capability. However, the Radio Classmark information is not included on the S-CDR.

Hence statistical information gathering (such as, what proportion of UK data traffic is carried by mobiles that support the PCS 1900 spectrum) has to be gathered from analysis of IMEIs rather than analysis of the Classmark field.

Hence, provided IMEISV is sent to the GGSN, this field need not be sent to the GGSN.

## A.2.4 LAC/RAC/CI at “record opening”

Various tariffs can be imagined that use cell ID information (e.g. a home cell tariff, whereby, if the context is opened in your home cell, a certain volume of data is charged at a lower rate). Statistical information gathering is also performed on a per cell basis.

Hence knowledge of the “full” cell ID at the GGSN would be useful.

Note that the “full” cell ID includes the MNC and MCC – but these fields have recently been added to R’97 and R’99 GTP. During the debate on this topic, it might have been argued that the 3G-SGSN did not know the Service Area Code where the mobile was activating the PDP context. However, this seems to be incorrect, because study of RANAP shows that the RNC is required to add the mobile’s current SAI to every Direct Transfer message sent to the SGSN,

There may be some concerns about sending cell-ID information between networks, however, it may well already be sent in the inter-operator TAP records! Also, as a “ball park figure”, 90% of subscribers are in their home network and 10% are roaming abroad, and the main usage of this field would be for the 90% of subscribers in their HPLMN.

So, it seems useful to add CGI/SAI information into the GTP signalling.

Further complexity arises however from the phrase “at record opening”. In both SGSN and GGSN, it is possible to raise partial CDRs. A “partial CDR” is potentially generated every 15 minutes and reduces the fraud risks associated with only generating a full CDR after many mega bytes have been sent on a PDP context that has been open for several days. From reading 32.215 it seems that the Cell ID needs to be inserted into the S-CDR every time a partial CDR is opened.

Full support of the Cell ID in Partial G-CDRs appears difficult, however, a useful compromise would seem to be to add CGI/SAI information to all GTP messages that can be sent by the SGSN as a result of receiving a RANAP Direct Transfer message. When the mobile is using the Gb interface, the SGSN should add the CGI to these messages.

Hence it is recommended to add CGI/SAI as an optional parameters in the following GTP messages:

- Create PDP Context Request
- Update PDP Context Request

Whether or not the CGI/SAI is included by the SGSN should be controlled by the SGSN operator according to the PLMN-ID of the GGSN.

## A.2.5 Access Point Name Operator Identifier

Section 14.13 of 3GPP TS 23.060 states that this field is part of the APN and that the APN is used to identify the GGSN. As such, it is logical that this field is included on the S-CDR.

However, there appears to be absolutely no need to transfer this field to the GGSN.

## A.2.6 System Type

On the S-CDR, this indicates whether the SGSN serves 2G or 3G cells. There is no code point for a combined 2G/3G SGSN, and no indication as to whether or not the combined SGSN has separate 2G and 3G Routing Areas!

It is recommended to add an “SGSN type” information element to the following GTP messages:

- Create PDP Context Request
- Update PDP Context Request

The contents of the “SGSN type” information element should be able to encode the following information, and permit future backwards compatible extension:

- 2G only SGSN



- 3G only SGSN
- Combined 2G/3G SGSN with all 2G cells in separate Routeing Areas to 3G cells
- Combined 2G/3G SGSN with some 2G and 3G cells in the same Routeing Area

Future additions might be needed to add in UMTS FDD/TDD differentiation, or if new Radio Access Technologies are adopted in the future.

Note that this “SGSN type” is different to the current “System type” field on the S-CDR. Whether or not the “System type” field on the S-CDR should be updated is FFS.

## A.2.7 CAMEL information

Some CAMEL functionality relates to SGSN based on-line charging. When using SGSN based on-line charging, GGSN based on-line charging is unlikely to also be used. However, other CAMEL functionality relates to APN ID manipulation; SGSN resource utilisation, and the provision for the gsmSCF to write a “free format field” to the main CDR. This information appears to be useful to transfer to the GGSN.

Overall it appears simplest to transfer all the S-CDR CAMEL Information as one parameter from the SGSN to the GGSN. The format and encoding of this information element should be constructed in an extensible manner, hopefully by just referencing the encoding already used within 3GPP TS 32.215.

This information element should be included in the Create PDP Context Request and Update PDP Context Request messages.

## A.2.8 RNC unsent data volume

If this information is useful to an SGSN, then it should be passed to the GGSN. In doing so it needs to be supplemented by the “2G SGSN unsent data volume”. Probably the unsent data volume could be accumulated by the new SGSN and sent to the GGSN at PDP context release. Providing this information to the new SGSN at inter SGSN change may require new GTP messages. Obtaining the information from the RNC may require additional use of existing RANAP signalling procedures.

However, as the value of sending this information from the RNC to the SGSN is as yet unclear, so far it is not agreed to add this information into the GTP signalling.

## A.3 RADIUS attributes

With the provision of the above information to the GGSN, then if RADIUS accounting is applied in the operator’s network then it is recommended that the following RADIUS attributes are added to the appropriate RADIUS messages:

- IMEISV
- CGI/SAI
- SGSN type
- CAMEL information

---

# Annex B: IMS and Flow based Charging

Flow Based Charging offers other ways that IMS service may be charged. Considering this, we need to study the usage of Flow Based Charging in relation to IMS.

The following needs to be studied:

1. Flow Based Charging needs to provide a solution to the issues solved by Rel5 IMS correlation, considering issues such as backwards compatibility.

2. It needs to be clarified whether having multiple filters provided to the GGSN (over Go and Gx) is an issue (and if it is, it needs to be resolved).
3. How charging rules can be applied to the SIP signalling used for IMS session control

## B.1 IMS SIP signalling

This section studies how flow based charging can be applied to the IMS signalling used for IMS session control.

It is to be noted though that the SIP signalling itself could carry different type of information that may be charged differently (e.g. SIP Session Invites, IMS messaging, etc.).

Possible ways to charge SIP at the bearer level could consist of:

- Applying pre-configured static rules in the TPF
- Requesting charging rules from the CRF
- Updating charging for the IMS signalling charging rules based specific triggers (e.g. time of day, modification of the session parameters, etc.) for a given user.

Note: the usage of the signalling indication needs to be further studied with respect to Flow Based Charging.

---

## Annex C: Change history

Change history							
Date	TSG #	TSG Doc.	CR	Rev	Subject/Comment	Old	New
2002-11					First draft		0.1.0
2003-02					Output version from SA2#29. Changes proposed in S2-030408rev2, S2-030409 and S2-030410 are implemented. Primarily architecture requirements and descriptive text added.	0.1.0	0.2.0
2003-03					Updated with approved contributions from SA2#30 S2-030947, S2-030951, S2-030952, S2-030953r3, S2-030954, and S2-030851  Some editorial fixes (formats, blank lines, etc)	0.2.0	0.3.0
2003-04					Updated with approved contributions from SA2#31 S2-031523, S2-031524, S2-031525, S2-031526, S2-031608	0.3.0	0.4.0
2003-04					Updated with minor editorial changes	0.4.0	0.4.1
2003-05					Updated with approved contributions from SA2#32 S2-032145, S2-032195 (was S2-032140 rev 1)	0.4.1	0.5.0
2003-07					Updated with approved contributions from SA2#33 S2-032581, S2-032715, S2-032716, S2-032717  Term "service flow" changed to "service data flow" throughout.  Term "service filter" changed to "service data flow filter" throughout.	0.5.0	0.6.0
2003-07					Additional editorial changes from "service flow" to "service data flow"	0.6.0	0.6.1
2003-08					Updated with approved contributions from SA2#34 (Brussels): S2-032989, S2-033155, S2-033156, S2-033157, S2-033158, S2-033159, S2-033257 (S2-033160 rev 1), S2-033161  Editorial fixes: - section 5.2.1 merged into what was 5.2.3. Sections 5.2.2 through 5.2.6	0.6.1	0.7.0

				then renumbered to one lower eg 5.2.2 -> 5.2.1. - Introduced TPF in abbreviations - Fixing some paragraphs to use correct style		
2003-09				First presentation for information to SA #21 plenary	0.7.0	1.0.0
2003-10				Updated with approved contributions from SA2#35 (Bangkok): S2-033506, S2-033507, S2-033508, S2-033511, S2-033512, S2-033759, S2-033780.  Editorial improvement to introduce term CRF. Other minor editorial corrections.	1.0.0	1.1.0
2003-11				Updated with approved contributions from SA2#36 (New York): S2-034078, S2-034099, S2-034266, S2-034268, S2-034342, S2-034343, S2-034344, S2-034345, S2-034386	1.1.0	1.2.0
2003-12				Updated with omitted contribution from SA2#36 (New York): S2-034262	1.2.0	1.3.0
2004-01				Updated with approved contributions from SA2#37 (Innsbruck): S2-040180, S2-040181, S2-040189, S2-040196, S2-040200, S2-040201, S2-040204, S2-040206, S2-040207, S2-040208, S2-040411, S2-040412, S2-040413, S2-040443, S2-040451, S2-040452	1.3.0	1.4.0