

3GPP TR 23.804 V7.1.0 (2005-09)

Technical Report

3rd Generation Partnership Project; Technical Specification Group Services and System Aspects; Support of SMS and MMS over generic 3GPP IP access (Release 7)



The present document has been developed within the 3rd Generation Partnership Project (3GPP™) and may be further elaborated for the purposes of 3GPP.

The present document has not been subject to any approval process by the 3GPP Organizational Partners and shall not be implemented. This Specification is provided for future development work within 3GPP only. The Organizational Partners accept no liability for any use of this Specification. Specifications and reports for implementation of the 3GPP™ system should be obtained via the 3GPP Organizational Partners' Publications Offices.

Keywords

UMTS, network, IP, circuit switching, SMS

3GPP

Postal address

3GPP support office address

650 Route des Lucioles - Sophia Antipolis
Valbonne - FRANCE
Tel.: +33 4 92 94 42 00 Fax: +33 4 93 65 47 16

Internet

<http://www.3gpp.org>

Copyright Notification

No part may be reproduced except as authorized by written permission.
The copyright and the foregoing restriction extend to reproduction in all media.

© 2005, 3GPP Organizational Partners (ARIB, ATIS, CCSA, ETSI, TTA, TTC).
All rights reserved.

Contents

Foreword	4
Introduction	4
1 Scope	5
2 References.....	5
3 Definitions and abbreviations.....	5
3.1 Definitions	5
3.2 Abbreviations.....	5
4 Overall Requirements.....	6
5 Architectural requirements and considerations	6
5.1 Architecture for support of SMS.....	6
5.1.1 IP Short Message Gateway (IP-MESSA GE-GW).....	7
5.1.2 HLR/HSS.....	7
5.1.2.1 Indication that the terminal is registered with an IP Short Message gateway.....	8
5.1.2.2 The address of the IP-MESSA GE-GW	8
5.1.3 Reference points.....	8
5.1.3.1 R1 reference point.....	8
5.1.3.2 R2 reference point.....	8
5.1.3.3 R3 reference point.....	8
5.1.3.4 R4 reference point.....	8
5.1.3.5 R5 reference point.....	9
5.1.3.6 R6 reference point.....	9
6 Security aspects	9
7 Charging aspects.....	9
7.1 SMS Charging	9
8 Procedures.....	9
8.1 Common registration procedure.....	10
8.2 De-registration procedure.....	10
8.2.1 UE initiated	10
8.2.2 IP-Message-GW initiated	11
8.3 Successful SMS MO delivery procedure	11
8.4 Successful SMS MT deliver procedure	12
8.5 Unsuccessful MT deliver procedure	13
8.6 SMS Alerting procedure.....	14
8.6.1 SMS Alerting procedure when UE has memory available to receive one or more short messages	14
8.7 Registration procedure using SIP/IMS	15
8.8 De-registration procedure using SIP/IMS	16
8.8.1 UE initiated	16
8.9 Successful SMS MO delivery procedure using SIP/IMS	17
8.10 Successful SMS MT deliver procedure using SIP/IMS	18
8.11 MMS procedures	19
8.11.1 MMS Origination procedure	19
8.11.2 MMS Terminating Procedure	21
8.11.3 MMS with SIP based Push.....	22
8.11.3.1 General.....	22
8.11.3.2 MMS Origination procedure.....	22
8.11.3.3 MMS Terminating Procedure.....	23
9 Conclusion and recommendations	24
Annex A: Change history.....	25

Foreword

This Technical Report has been produced by the 3rd Generation Partnership Project (3GPP).

The contents of the present document are subject to continuing work within the TSG and may change following formal TSG approval. Should the TSG modify the contents of the present document, it will be re-released by the TSG with an identifying change of release date and an increase in version number as follows:

Version x.y.z

where:

- x the first digit:
 - 1 presented to TSG for information;
 - 2 presented to TSG for approval;
 - 3 or greater indicates TSG approved document under change control.
- y the second digit is incremented for all changes of substance, i.e. technical enhancements, corrections, updates, etc.
- z the third digit is incremented when editorial only changes have been incorporated in the document.

Introduction

There is interest in providing 3GPP messaging services across WLAN, and, more generically across any form of 3GPP IP access. Although some initial work has been documented within annex D of the WLAN interworking stage 2 (TS 23.234), there are many topics that cannot be tackled in isolation.

These include (but are not limited) to:

- a) the impact on existing SMS services and the HSS (e.g. the impact on SMS message waiting flags and on voice mail services.) If this is not studied, then there is a risk that existing operator services will be degraded by the introduction of "SMS over WLAN";
- b) the investigation of the use of SS7 and/or IP protocols to communicate with the SMS-GMSC/SMS-IW MSC and the HSS;
- c) providing SMS/MMS services over any 3GPP IP access needs authentication (e.g. specification of security mechanisms);
- d) potential synergies between solutions for SMS, MMS and IMS messaging (e.g. common (re)registration mechanisms);
- e) addressing mechanisms when multiple IP-SMS Gateways are in use; and
- f) reliable deregistration mechanisms to cope with cases when the 3GPP IP access link is lost suddenly (e.g. when WLAN coverage is lost).
- g) mechanisms to handle SMS and MMS when there is more than one 3GPP IP connection active with the mobile (e.g. a WLAN/GPRS/UMTS card may be GPRS attached and/or CS attached while also having the WLAN connection active).

The overall objective is to enhance the 3GPP specifications to support delivery of SMS and MMS over WLAN and any other 3GPP IP access in a manner which guarantees existing SMS and MMS services are not degraded.

1 Scope

The present document investigates solutions for providing 3GPP messaging services across WLAN, and, more generically across any form of IP access that is part of the 3GPP system.

2 References

The following documents contain provisions which, through reference in this text, constitute provisions of the present document.

- [1] 3GPP TS 21.905: "Vocabulary for 3GPP Specifications".
- [2] 3GPP TS 22.101: "Service principles".
- [3] 3GPP TS 23.002: "Network architecture".
- [4] 3GPP TS 23.003: "Numbering, addressing and identification".
- [5] 3GPP TS 23.040: "Technical Realisation of the Short Message Service (SMS)".
- [6] 3GPP TS 23.060: "GPRS; Service description".
- [7] 3GPP TS 23.234: "3GPP system to Wireless Local Area Network (WLAN) interworking; System description".
- [8] 3GPP TS 33.234: "WLAN Interworking Security".
- [9] 3GPP TS 29.002: "Mobile Application Part (MAP) specification".
- [10] 3GPP TS 23.140: "Multimedia Messaging Service (MMS)".
- [11] 3GPP TS 24.011: "Point-to-Point (PP) Short Message Service (SMS) support on mobile radio interface".
- [12] 3GPP TS 23.228: "IP Multimedia (IM) Subsystem – Stage 2".

3 Definitions and abbreviations

3.1 Definitions

For the purposes of the present document, the following terms and definitions apply.

UE: In the context of the present document, the UE uses IP based transport for messaging.

3.2 Abbreviations

For the purposes of the present document, the following abbreviations apply:

AKA	Authentication and Key Agreement
CCF	Charging Collection Function
CGw	Charging Gateway
DHCP	Dynamic Host Configuration Protocol
GTP	GPRS Tunnelling Protocol
HLR	Home Location Register
HPLMN	Home PLMN
HSS	Home Subscriber Server
IP	Internet Protocol

IP-MESSAGE-GW	IP Short Message Gateway
PLMN	Public Land Mobile Network
SIM	Subscriber Identity Module
UE	User Equipment
UMTS	Universal Mobile Telecommunications System
URL	Universal Resource Locator
USIM	UMTS SIM

4 Overall Requirements

Editor's Note: This section will describe the overall requirements from a user/network operator point of view.

The current 3GPP specifications shall be enhanced to support delivery of SMS and MMS over WLAN and other IP Connectivity Access Networks (IP-CANs).

It shall allow an IP based user to access the SMS/MMS in a secure manner.

It shall support a common registration/de-registration procedure for SMS and MMS delivery.

SMS/MMS over IP-CANs shall not degrade the existing services that use SMS/MMS service functionality.

A reliable deregistration mechanism shall be provided when 3GPP IP access is lost (e.g. when WLAN coverage is lost).

When more than one 3GPP IP connections are activated (e.g. UE with combined WLAN/GPRS/UMTS card may be GPRS attached and/or CS attached while the WLAN connection is activated), operator's preference and user's preference, when allowed by operator, shall be taken into account to select the connection to use for both mobile originated and terminated SMS/MMS.

IMS-based messaging shall be used end-to-end in case originating UE used IMS-based messaging and the participating networks and user equipments have the appropriate IMS messaging capabilities, and depending on operator preferences.

Provisioning of UICC configuration data over generic 3GPP IP access shall be supported.

5 Architectural requirements and considerations

Editor's Note: This section will describe requirements that apply to the architecture design and considerations which will be used when making decisions on the preferred architectural alternative.

5.1 Architecture for support of SMS

The architecture for support of IP delivery and origination of SMS messages is illustrated in figure 5.1. The SM-SC and GMSC/SMS-IW MSC are defined in TS 23.040 [5]. The IP Short Message Gateway IP-MESSAGE-GW communicates between the UE and the GMSC/SMS-IW MSC.

The intention of this architecture is that it could be realised through re-use of existing messaging protocols supported by the UE e.g. IMS or MMS. The primary purpose of this architecture description is therefore to describe the interaction between the IP SM Gateway and the existing elements supporting the Short Message Service (GMSC/SMS-IW MSC, SM-SC and HLR/HSS).

The IP SM Gateway should be considered as consisting of all the functional entities needed to interwork between the chosen existing messaging protocol(s) and the existing SMS elements. For example, in the case IMS Messaging is chosen, the requirements on the IP SM Gateway specified here could be met by a combination of the CSCFs and an IMS Application Server which interworks to the GMSC/SMS-IW MSC.

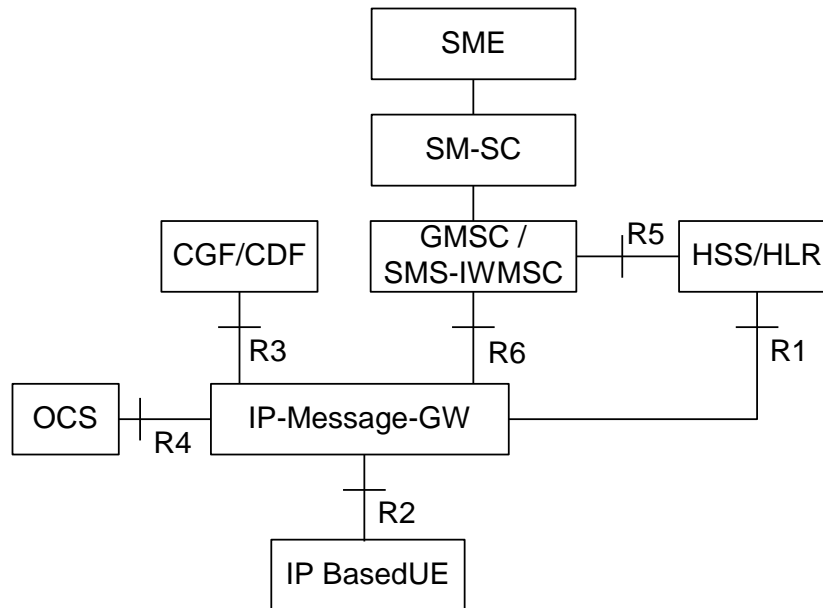

NOTE: IP-Message-GW is used in place of the MSC or SGSN in case of SMS transfer over IP connection.

Figure 5.1: Architecture for SMS support with an IP attached terminal

5.1.1 IP Short Message Gateway (IP-MESSAGE-GW)

The IP-MESSA GE-GW shall provide the protocol interworking for delivery of the short message between the UE and the GSM/UMTS network. The functions of this network element are :

- To connect to the GMSC using established MAP protocols over SS7, appearing to the GMSC as an MSC or SGSN using the E or Gd reference points;
- To connect to the SMS-IWMSC using established MAP protocols over SS7, appearing to the SMS-IWMSC as an MSC or SGSN using the E or Gd reference points;
- To communicate with the UE using IP based protocols maintaining the format and functionality of the SMS message. It is intended that existing messaging protocols supported by the UE should be reused for this purpose;
- To maintain the association between the MSISDN and the IP address of the terminal;
- Support registration and authentication of the UE for SMS services ;
- Support of security associations between UE and IP-MESSA GE-GW .
- The proper reliability of IP connection between IP-MESSA GE -GW and UE should be assured.
- Provide interworking between SMS/MMS service in the CS/PS domain and the IP-MESSA GE-GW . The IP-MESSA GE-GW interconnects e.g. two PLMNs, where one PLMN provides SMS/MMS over IP and the other PLMN does not support or is not willing to transport SMS/MMS over IP.

5.1.2 HLR/HSS

In the routing of an SMS message, the SMS-GMSC performs a MAP request to the HLR/HSS "send routing information for short message" as defined in TS 29.002 [9] to determine the address of the MSC or SGSN to which to route the short message. When the UE is connected only to a GSM/UMTS network, the "send routing information for short message" returns the address of the MSC or SGSN for delivery of SMS message. In the event that the UE is registered with an IP Short Message Gateway, the HLR/HSS may return the address of the IP-MESSA GE-GW in the "send routing information for short message". As such, the HLR/HSS shall support the following functionality:

- An indication that the terminal is registered with an IP Short Message Gateway (e.g. an internal flag) for delivery of SMS;

- The SS7 MAP address of the IP-MESSAGE-GW;
- The logic necessary to act on the fact that the terminal is IP connected and return the IP-MESSAGE-GW address.

The mechanism for prioritizing whether the short message is delivered via a GSM/UMTS or a WLAN connection when the terminal is simultaneously connected to both access networks is outside the scope of this specification.

5.1.2.1 Indication that the terminal is registered with an IP Short Message gateway

In order to be able to return the address of the IP-MESSAGE-GW in response to a "SendRoutingInfoForShortMsg" request from the GMSC, the HLR/HSS needs to have an indication that the terminal is registered with an IP Short Message Gateway and that this is the preferred method for delivery of short messages.

The IP Short Message Gateway maintains the UE's registration status. On registration, the IP Short Message Gateway shall send a message to the HLR/HSS indicating that the UE has successfully registered.

5.1.2.2 The address of the IP-MESSAGE-GW

The address of the IP-MESSAGE-GW associated with a registered UE may either be pre-defined as a single address in the HLR/HSS or dynamically configured during the registration process, depending on information received from the IP-MESSAGE-GW.

5.1.3 Reference points

Editor's note: the reference points R1~R6 are temporary named, the formal names are FFS.

5.1.3.1 R1 reference point

The R1 reference point enables the correct routing of an SMS message for an UE. It shall be possible to reuse the existing Gr reference point.

The R1 reference point supports the following functions:

1. IP-IWF Registration Request (from IP-Message-GW to HLR/HSS);
2. IP-IWF Registration Response (from HLR/HSS to IP-Message-GW);
3. De-register Request (from IP-Message-GW to HLR/HSS);
4. De-register Response (from HLR/HSS to IP-Message-GW).

5.1.3.2 R2 reference point

The R2 reference point enables the UE to access to the 3GPP network to use the short message service. It shall be possible for the UE to connect to the IP-Message-GW over various IP network, e.g. WLAN, Internet, etc.

NOTE: The details of access over various IP network is out of the scope of this specification.

5.1.3.3 R3 reference point

The R3 reference point enables transport of IP-Message-GW offline charging information. The R3 reference point is subject to investigation in SA WG5.

5.1.3.4 R4 reference point

The R4 reference point allows credit control for IP-Message-GW online charging. The functionalities required across the R4 reference point shall use existing functionalities and mechanisms, e.g. based on CAMEL.

5.1.3.5 R5 reference point

The R5 reference point is a slight enhancement of reference point C and the corresponding protocol is based on the MAP. The R5 reference point enables the HLR to return the MSC and/or SGSN and/or IP-Message-GW address as routing information to the SMS-GMSC.

5.1.3.6 R6 reference point

The R6 reference point enables the delivery of the short message between IP-Message-GW and GMSC/SMS-IWMSC. It shall be possible to reuse the existing E reference point or Gd reference point.

6 Security aspects

Editor's Note: This section will describe the security aspects that may need to be considered when providing SMS and MMS over IP networks.

7 Charging aspects

Editor's Note: This section will describe the charging aspects that may need to be considered when providing SMS and MMS over IP networks.

An IP access flag shall be generated in the IP-Messaging-GW and may be used to charge a message in an IP access rate. Also, the flag shall be passed in the individual SMs/MMs towards the SMSC and MMSC respectively to allow an operator to charge a user in the IP access rate. Furthermore, the IP access flag can be used to indicate IP access status and for inter-operator accounting.

7.1 SMS Charging

The following functionality and requirements have been identified:

- The IP-Message-GW shall collect charging information of a user for mobile originated SMS.
- The IP-Message-GW shall collect charging information of a user for mobile terminated SMS.
- The IP-Message-GW may collect inter-operator charging information.
- The IP-Message-GW shall support offline and online charging mechanisms.
- The mechanism of CDR generated by the IP-Message-GW is same to the existing mechanism generated by the MSC/SGSN.

8 Procedures

Editor's Note: This section will describe the procedures for the functional elements contained in the architecture.

8.1 Common registration procedure

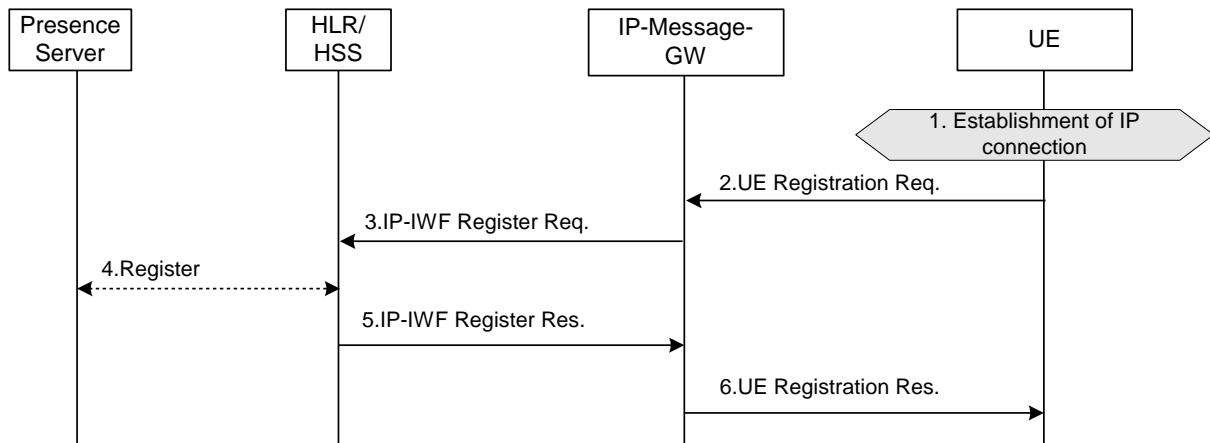

Figure 8.1: Common registration procedure over generic 3GPP IP access

- 1) The UE establishes IP connection.
- 2) At any time after the establishment of the IP connection, the UE sends secure Registration Request to the IP-Message-GW, including the identity to identify the UE, e.g. NAI identity. The exact mechanism to secure the message could be GAA or tunnelling defined for 3GPP IP access. It shall be studied how existing registration solutions to IP-based services can be re-used (e.g. SIP registration).
- 3) The IP-Message-GW retrieves IMSI from the username part of the provided NAI identity, the IP-Message-GW registers the UE's IMSI with the HLR/HSS.
- 4) The HLR/HSS stores the IP-Message-GW address of the UE, sets a flag indicating the UE is IP connected. Also, the HLR/HSS informs the Presence Server that the UE is IP connected.
- 5) Upon successful registration, the HLR/HSS returns the MSISDN, the subscriber data of the UE in the registration response to the IP-Message-GW.
- 6) The IP-Message-GW stores the MSISDN to IP address mapping in a local database, and returns the registration response to the UE.

NOTE: The step 2~6 may be utilized as a re-registration procedure in case a certain timer expires after the UE was registered.

8.2 De-registration procedure

8.2.1 UE initiated

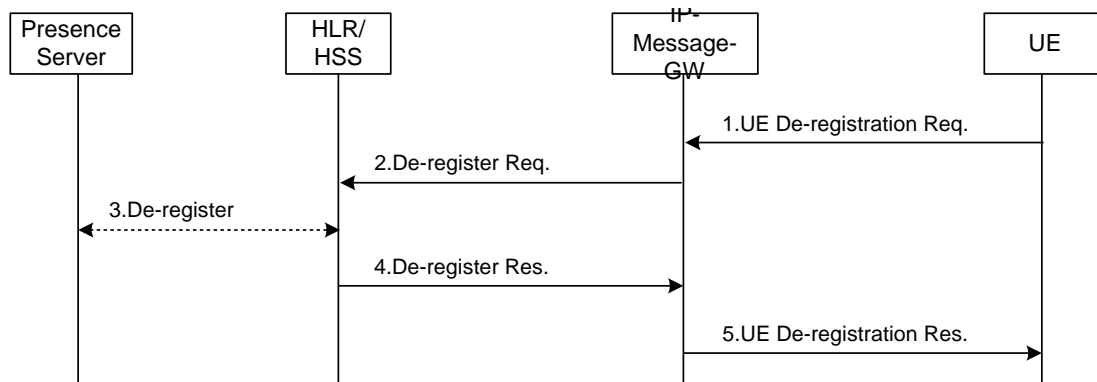

Figure 8.2-1: UE initiated de-registration procedure over generic 3GPP IP access

- 1) At any time after the common registration procedure, the UE may initiate a de-registration procedure. The UE sends the De-registration request to the IP-Message-GW.

- 2) The IP-Message-GW retrieves IMSI from the username part of the provided NAI identity, the IP-Message-GW sends the de-registration to the HLR/HSS.
- 3) The HLR/HSS de-registers the IP connected information of the UE, i.e. deletes the IP-Message-GW address, and removes the IP connected flag. If configured, the HLR/HSS informs the Presence Server that the UE is IP disconnected.
- 4) HLR/HSS returns IP-Message-GW the De-register Response.
- 5) IP-Message-GW deletes the MSISDN to IP address mapping in the local database, and returns the De-registration response to the UE.

8.2.2 IP-Message-GW initiated

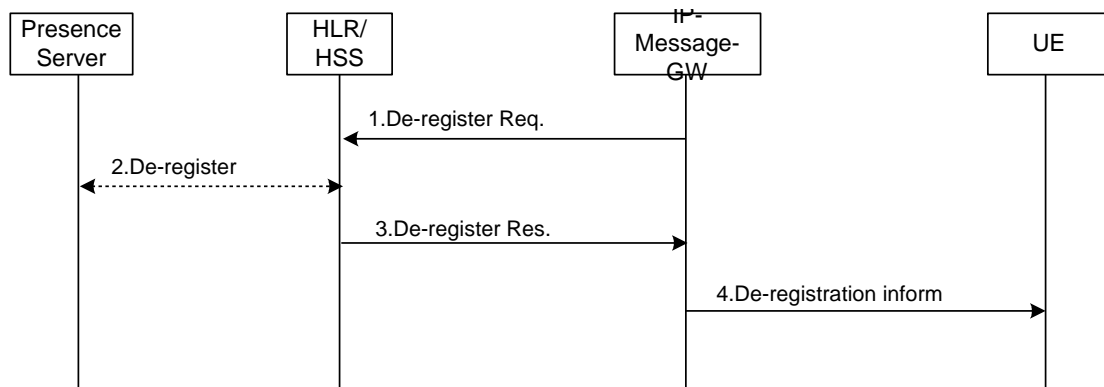

Figure 8.2-2: IP-Message-GW initiated de-registration procedure

- 1) If a long guard timer in the IP-Message-GW expires, the IP-Message-GW shall initiate a de-registration procedure. The IP-Message-GW sends de-registration to the HLR/HSS and then deletes the MSISDN and IP address mapping in the local database.
- 2) The HLR/HSS de-registers the IP connected information of the UE, i.e. deletes the IP-Message-GW address, and removes the IP connected flag. If configured, the HLR/HSS informs the Presence Server that the UE is no longer connected for SMS/MMS "across IP".
- 3) HLR/HSS returns IP-Message-GW De-register Response.
- 4) The IP-Message-GW informs UE this de-registration.

8.3 Successful SMS MO delivery procedure

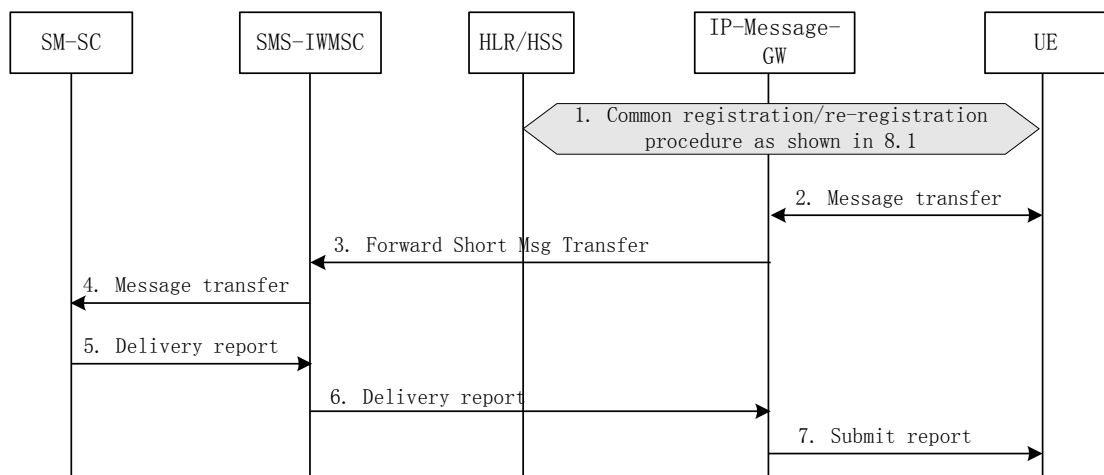

Figure 8.3: Successful SMS MO submit procedure over IP connection

- 1) The UE registers to the IP-Message-GW.
- 2) The UE submits SMS message to the IP-Message-GW. It shall be studied how existing IP-based messaging solutions can be re-used.
- 3) Upon receipt the delivered SMS message, the IP-Message-GW performs service authorization based on the subscriber data retrieved from the HLR/HSS in the registration/re-registration procedure as described in clause 8.1. If the result of service authorization is negative, the IP-Message-GW shall return the appropriate error information to the UE in a failure report. Otherwise, the IP-Message-GW extracts the SMS message, retrieves the MSISDN from the IP address of the UE using the local database, and then forwards the extracted short message with MSISDN to the SMS-IWMSC using standard MAP signalling (as TS 23.040) exactly as if it was an MSC or SGSN.
- 4) The SMS-IWMSC forwards the SMS message to the SM-SC (see TS 23.040).
- 5) The SM-SC sends submit report to SMS-IWMSC (see TS 23.040).
- 6) The SMS-IWMSC sends submit report to IP-Message-GW (see TS 23.040).
- 7) The IP-Message-GW sends submit report to UE.

8.4 Successful SMS MT deliver procedure



Figure 8.4: Successful SMS MT deliver procedure over IP connection

- 1) The IP-based UE registers at the IP-Message-GW.
- 2) The SM-SC forwards the SMS message to the SMS-GMSC.
- 3) The SMS-GMSC sends a request, including an indication that the SMS-GMSC supports IP messaging to the HLR/HSS to retrieve routing information. If this indication is set, the SMS-GMSC is able to receive and process the three E.164 addresses of MSC, SGSN and IP-Message-GW. Thus, when a user registered on an IP-Message-GW for delivery of SMS messages, the HLR/HSS returns the address of the IP-Message-GW along with the addresses of the MSC and SGSN, if available. If the indication of IP messaging support is not received from the SMS-GMSC and the HLR/HSS has three E.164 addresses of MSC, SGSN and IP-Message-GW stored, the HLR/HSS returns a list of the addresses in order of priority to the SMS-GMSC depending on the indicated capabilities (i.e. if the GPRS Support Indicator is received, two addresses, otherwise only one address, should be sent). The HLR/HSS should spoof one of the returned addresses with the IP-Message-GW address, if it is to be sent.
- 4) If and/or when the SMS-GMSC chooses to deliver the "SMS over IP", the SMS-GMSC delivers the short message to IP-Message-GW, in the same manner that it delivers the short message to an MSC or SGSN, carrying the MSISDN of the destination UE.
- 5) The IP-Message-GW uses the MSISDN of the destination UE to retrieve its IP address from the local database, and then the IP-Message-GW delivers the SMS to the UE. It shall be studied how existing IP-based messaging solutions can be re-used.

- 6) The IP-Message-GW sends a deliver report back to the SMS-GMSC (see TS 23.040).
- 7) The SMS-GMSC sends a SM deliver report status to the HLR/HSS (see TS 23.040).
- 8) The SMS-GMSC sends a deliver report to the SM-SC (see TS 23.040).

8.5 Unsuccessful MT deliver procedure

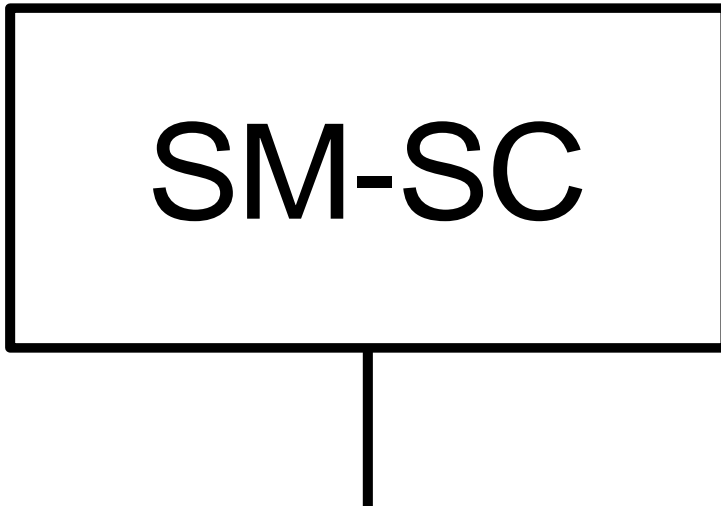

Figure 8.5: Unsuccessful SMS MT deliver procedure over IP connection

- 1) The UE registers at the IP-Message-GW.
- 2) The SM-SC forwards the SMS message to the SMS-GMSC.
- 3) The SMS-GMSC sends a request, including an indication that the SMS-GMSC supports IP messaging to the HLR/HSS to retrieve routing information. If this indication is set, the SMS-GMSC is able to receive and process the three E.164 addresses of MSC, SGSN and IP-Message-GW. Thus, when a user registered on an IP-Message-GW for delivery of SMS messages, the HLR/HSS returns the address of the IP-Message-GW along with the addresses of the MSC and SGSN if available. If the indication of IP messaging support is not received from the SMS-GMSC and the HLR/HSS has three E.164 addresses of MSC, SGSN and IP-Message-GW stored, the HLR/HSS returns a list of the addresses in order of priority to the SMS-GMSC depending on the indicated capabilities (i.e. if the GPRS Support Indicator is received, two addresses, otherwise only one address, should be sent). The HLR/HSS should spoof one of the returned addresses with the IP-Message-GW address, if it is to be sent.
- 4) If and/or when the SMS-GMSC chooses to deliver the "SMS over IP", the SMS-GMSC delivers the short message to IP-Message-GW, in the same manner that it delivers the short message to an MSC or SGSN, carrying the MSISDN of the destination UE.
- 5) The IP-Message-GW uses the MSISDN of the destination UE to retrieve its IP address from the local database. The IP-Message-GW then delivers the SMS to the UE. However, the message cannot be delivered successfully.
- 6) The IP-Message-GW returns a failure deliver report back to the SMS-GMSC (see TS 23.040).
- 7) In case the reason of failure deliver report is not Memory Capacity Exceeded, based on the addresses received from the HLR/HSS in step 3, the SMS-GMSC shall attempt to deliver the short message via SGSN and/or MSC, as described in TS 23.040. Otherwise, SMS-GMSC returns a failure deliver report back to the SM-SC, referring to the describing in TS 23.040.
- 8) If all delivery attempts fail, then the SMSC shall decide whether to set the message waiting flags. If it so decides, the SMSC sends MAP-REPORT-SM-DELIVERY-STATUS to the HLR/HSS with the address of the SM-SC having initiated the SMS MT delivery.

The indication to the HLR/HSS is extended to indicate the type of SMSC (e.g. normal/voice mail/video mail server).

- 9) The SMS-GMSC sends a SM deliver report status to the SM-SC (see TS 23.040).

8.6 SMS Alerting procedure

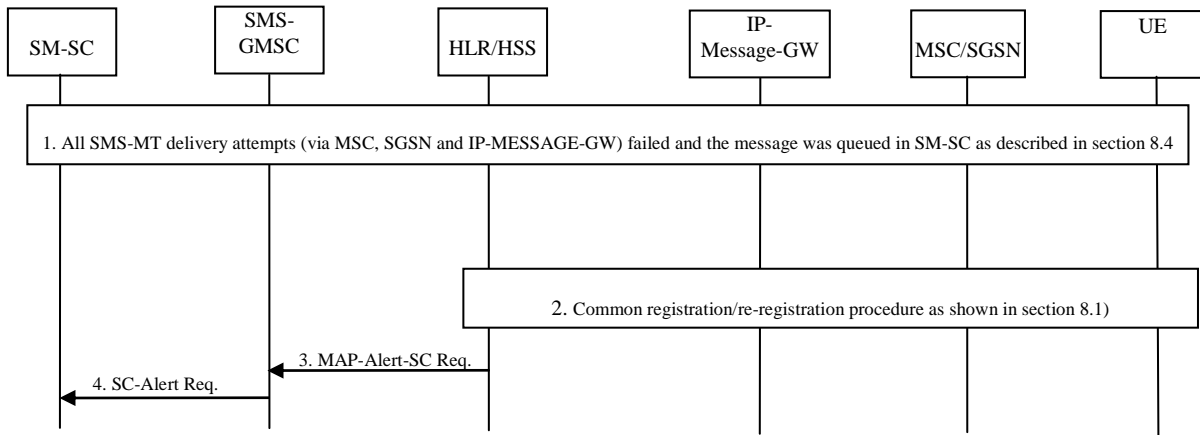

Figure 8.6: SMS Alerting procedure over IP connection

- 1) If all SMS MT delivery attempts (via MSC, SGSN and IP-MESSAGE-GW) failed (e.g. because the UE was not reachable), the message to be transferred to UE is queued in the SM-SC.
- 2) UE initiates the common registration procedure as described in section 8.1 (e.g. it has recovered the IP connection to WLAN),
- 3) If the HLR/HSS receives the registration request from UE and if the MNRF and/or MNGF flags are set, it sends MAP-Alert-SC] request message with the list of the SM-SC addresses to SMS-IWMSC as described in TS 23.040.
- 4) The SMS-IWMSC sends SC Alert request messages to SM-SCs whose addresses are informed by the HLR/HSS in step 3).

8.6.1 SMS Alerting procedure when UE has memory available to receive one or more short messages

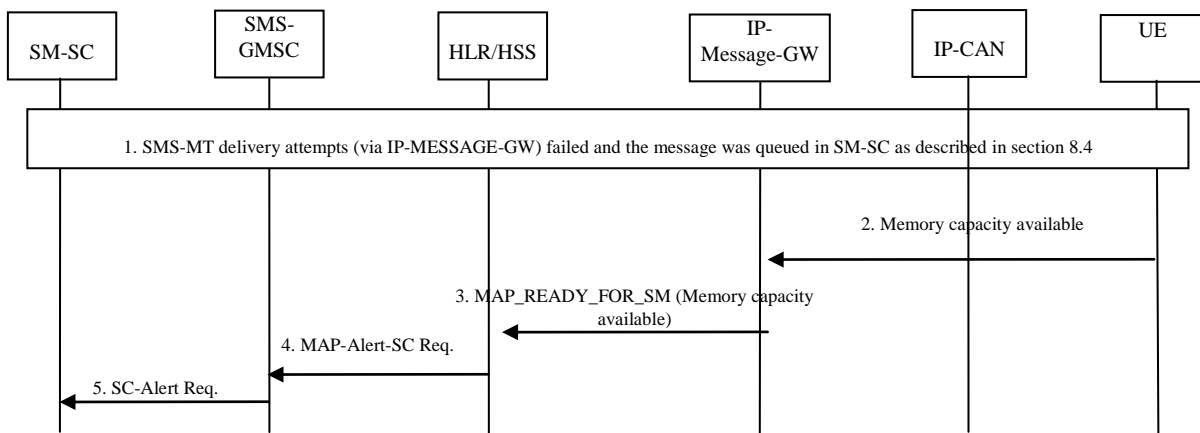

Figure 8.6.a: SMS Alerting procedure over IP connection when UE's memory available

- 1) If SMS MT delivery attempts (via IP-MESSAGE-GW) failed because the UE's Memory Capacity Exceeded, the message to be transferred to UE is queued in the SM-SC.

- 2) UE sends a message to IP-MESSA GE-GW indicating that the UE has memory available to receive one or more short messages.
- 3) IP-MESSA GE-GW notifies the HLR/HSS of memory available in the UE.
- 4) If the HLR/HSS receives the indication that the UE has memory available to receive one or more short messages, it transfer alert information with the SC addresses and the MSIsdn-Alert to MSC as described in TS 23.040.
- 5) The GMSC sends SC Alert request messages to SM-SCs whose addresses are informed by the HLR/HSS in step 4).

Editor's note: The feasibility of stage 3 realization is FFS.

8.7 Registration procedure using SIP/IMS

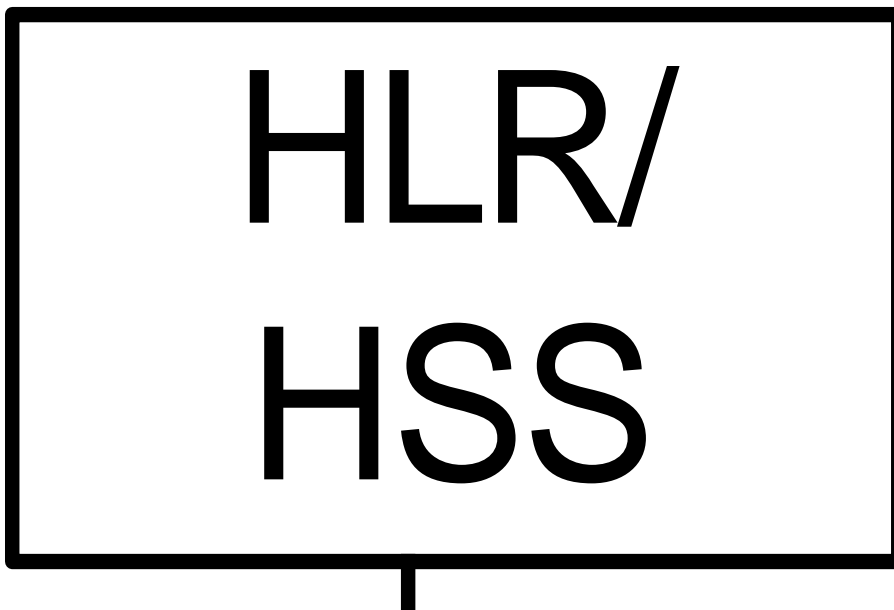

Figure 8.7: Registration procedure over generic 3GPP IP access using SIP/IMS registration (according to TS 23.228 [12])

- 1) The UE establishes IP connection.
- 2) At any time after the establishment of the IP connection, the UE registers at the S-CSCF according to the IMS registration procedures. Note, that for simplicity not all messages between UE and S-CSCF and between S-CSCF and HLR/HSS are shown in detail. In addition, I-CSCF and P-CSCF are also not shown.
- 3) S-CSCF checks the filter information retrieved from the HLR/HSS during the IMS registration procedure.
- 4) After successful IMS registration and based on the retrieved filter information the S-CSCF informs the IP-Message-GW (AS) about the registration of the user.
- 5) The IP-Message-GW (AS) sends IP-IWF Register Req to the HLR/HSS and registers the UE's and it's own address with the HLR/HSS. It is FFS, whether steps 5 and 6 are needed. Alternatively the IP-Message-GW (AS) address can be pre-configured in the HLR/HSS, either globally per HLR/HSS or on a per subscriber basis.
- 6) The HLR/HSS stores the IP-Message-GW (AS) address together with the address of the UE and responses to the IP-Message-GW (AS) with IP-IWF Register Res, including the subscriber data needed for providing service..
- 7) The IP-Message-GW (AS) stores the downloaded subscriber data and returns 200 OK to the S-CSCF.

8.8 De-registration procedure using SIP/IMS

8.8.1 UE initiated

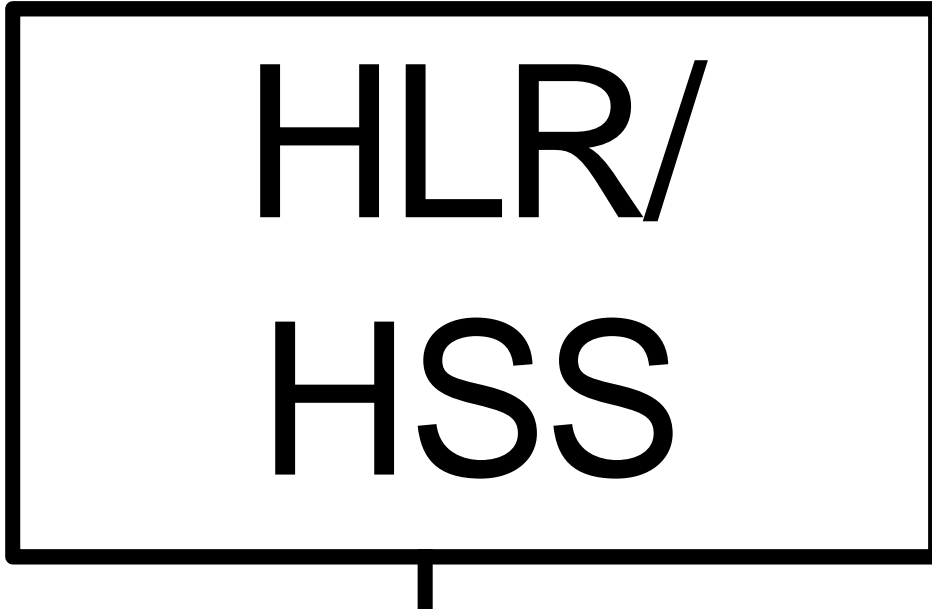

Figure 8.8: UE initiated IMS de-registration procedure over generic 3GPP IP access (according to TS 23.228 [12])

- 1) At any time after the registration procedure, the UE may initiate a de-registration procedure. The UE sends the SIP REGISTER message with Expires header having value 0 to the S-CSCF. Note, that I-CSCF and P-CSCF are not shown in this figure.
- 2) S-CSCF responds to the UE with a 200 OK.
- 3) S-CSCF checks the filter information retrieved from the HLR/HSS during the IMS registration procedure.
- 4) Based on filter information the S-CSCF informs the IP-Message-GW (AS) about the de-registration of the user.
- 5) The IP-Message-GW (AS) de-registers the UE at the HLR/HSS sending a De-register Req. It is FFS, whether steps 5 and 6 are needed. If the IP-Message-GW (AS) address is pre-configured in the HLR/HSS, steps 5 and 6 can be omitted.
- 6) The HLR/HSS de-registers the UE, i.e. removes the IP-Message-GW address, and responds to the IP-Message-GW (AS) with De-register Res.
- 7) The IP-Message-GW (AS) returns 200 OK to the S-CSCF.

8.9 Successful SMS MO delivery procedure using SIP/IMS

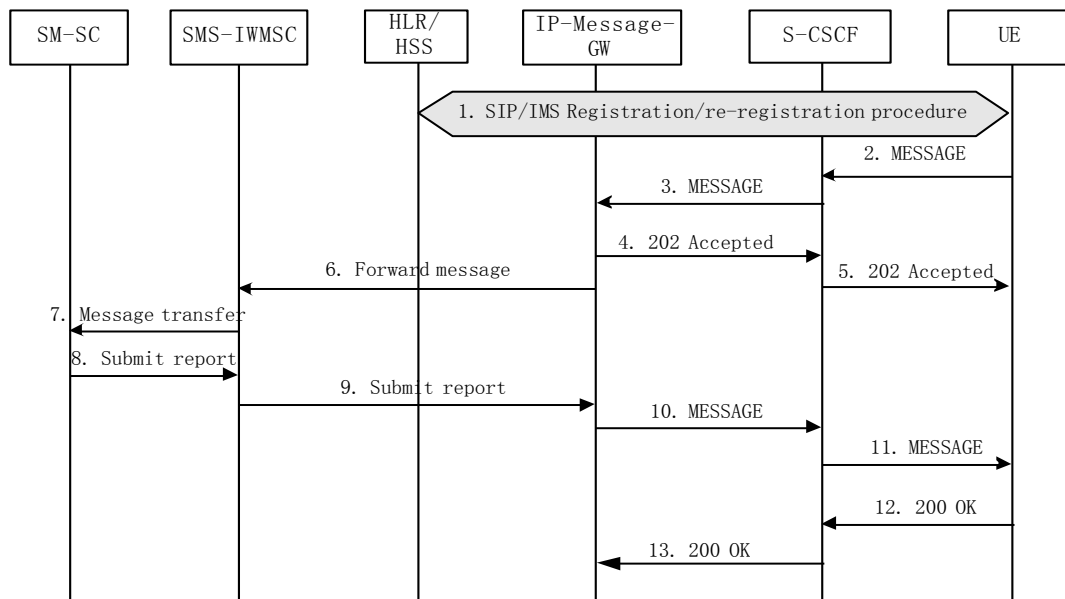

Figure 8.9: Successful SMS MO submit procedure over SIP/IMS

- 1) The UE registers to S-CSCF according the IMS registration procedure. Note, that I-CSCF and P-CSCF are not shown in this figure.
- 2) UE submits the SMS message to the S-CSCF using the SIP MESSAGE method.
- 3) S-CSCF forwards the MESSAGE to IP-Message-GW (AS) based on filter information.
- 4) If the IP-Message-GW (AS) has not received the registration before, the IP-Message-GW (AS) returns failure to the UE via S-CSCF. Otherwise, the IP-Message-GW performs service authorization based on the subscriber data retrieved from the HSS in the registration/re-registration procedure as described in clause 8.7. If the result of service authorization is negative, the IP-Message-GW shall return the appropriate error information to the UE in a failure report. Otherwise, IP-Message-GW (AS) indicates that the message is sent by using SIP 202 Accepted.
- 5) Message sent information is forwarded by S-CSCF to UE using SIP 202 Accepted.
- 6) IP-Message-GW (AS) extracts the SMS message and forwards it towards SM-SC via the SMS-IWMSC using standard MAP signalling (as described in TS 23.040). The address of SM-SC is extracted either from R-URI of the MESSAGE or in the SM content. It is FFS whether the SIP MESSAGE method contains an SMS indication provided by the UE or whether the IP-Message-GW (AS) uses e.g. the SMS service to transport text messages.
- 7) The SMS-IWMSC forwards the SMS message to the SM-SC (see TS 23.040).
- 8) SM-SC sends submit report to SMS-IWMSC (see TS 23.040).
- 9) SMS-IWMSC sends submit report to IP-Message-GW (AS) (see TS 23.040).
- 10) IP-Message-GW (AS) sends Submit report to S-CSCF using SIP MESSAGE.
- 11) S-CSCF sends the submit report to the UE using SIP MESSAGE. It is FFS how the UE recognizes the SIP MESSAGE as a submit report message.
- 12) UE acknowledges the submit report using 200 OK.
- 13) Acknowledgement of the submit report is forwarded by S-CSCF to IP-Messaging-GW (AS) by using 200 OK.

8.10 Successful SMS MT deliver procedure using SIP/IMS

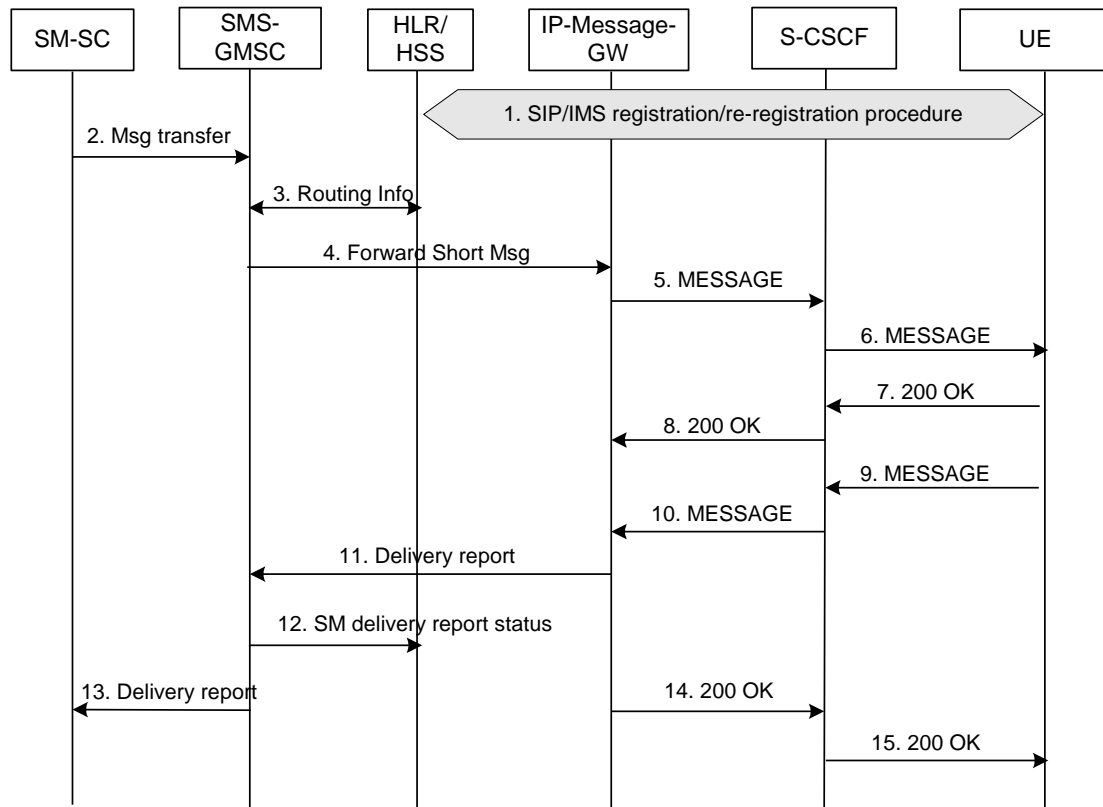

Figure 8.10: Successful SMS MT delivery procedure over SIP/IMS

- 1) The UE registers to the S-CSCF according to the IMS registration procedure. Note, that I-CSCF and P-CSCF are not shown in this figure.
- 2) The SM-SC forwards the SMS message to the SMS-GMSC.
- 3) The SMS-GMSC sends a request, including an indication that the SMS-GMSC supports IP messaging to the HLR/HSS to retrieve routing information. If this indication is set, the SMS-GMSC is able to receive and process the three E.164 addresses of MSC, SGSN and IP-Message-GW. Thus, when a user is IMS registered for delivery of SMS messages, the HLR/HSS returns the address of the IP-Message-GW along with the addresses of the MSC and SGSN, if available. If the indication of IP messaging support is not received from the SMS-GMSC and the HLR/HSS has three E.164 addresses of MSC, SGSN and IP-Message-GW stored, the HLR/HSS returns a list of the addresses in order of priority to the SMS-GMSC depending on the indicated capabilities (i.e. if the GPRS Support Indicator is received, two addresses, otherwise only one address, should be sent). The HLR/HSS should spoof one of the returned addresses with the IP-Message-GW address, if it is to be sent.
- 4) SMS-GMSC delivers the short message to IP-Message-GW (AS), in the same manner that it delivers the short message to an MSC or SGSN, carrying the MSISDN of the target UE.
- 5) The IP-Message-GW (AS) uses the TEL-URL of the target UE to populate the SIP Request URI, and then sends the short message using SIP MESSAGE towards the S-CSCF.
- 6) S-CSCF forwards the SIP MESSAGE to the UE.
- 7) The UE responds with a 200 OK to the S-CSCF (Note: This is not yet the deliver report, because 200 OK may not carry such information.)
- 8) S-CSCF responds with a 200 OK to IP-Message-GW (AS).
- 9) The UE sends a deliver report using SIP MESSAGE to the S-CSCF.
- 10) Based on filter information S-CSCF forwards the SIP MESSAGE to the IP-Message-GW (AS).

- 11) The IP-Message-GW (AS) sends a deliver report to the SMS-GMSC. It is FFS how the IP-Message-GW (AS) recognizes the SIP MESSAGE as a deliver report message from the UE.
- 12) The SMS-GMSC sends a SM deliver report status to the HLR/HSS.
- 13) The SMS-GMSC sends a deliver report to the SM-SC.
- 14) IP-Message-GW (AS) acknowledges the deliver report to S-CSCF using 200 OK.
- 15) S-CSCF acknowledges the deliver report to the UE using 200 OK.

8.11 MMS procedures

There is possibly more than one solution to deliver MMS over generic IP access, e.g. using capabilities provided by IMS or using HTTP. It will be further studied for the best solution. Following flows are the example flows of using IMS to deliver MMS over generic IP access.

8.11.1 MMS Origination procedure

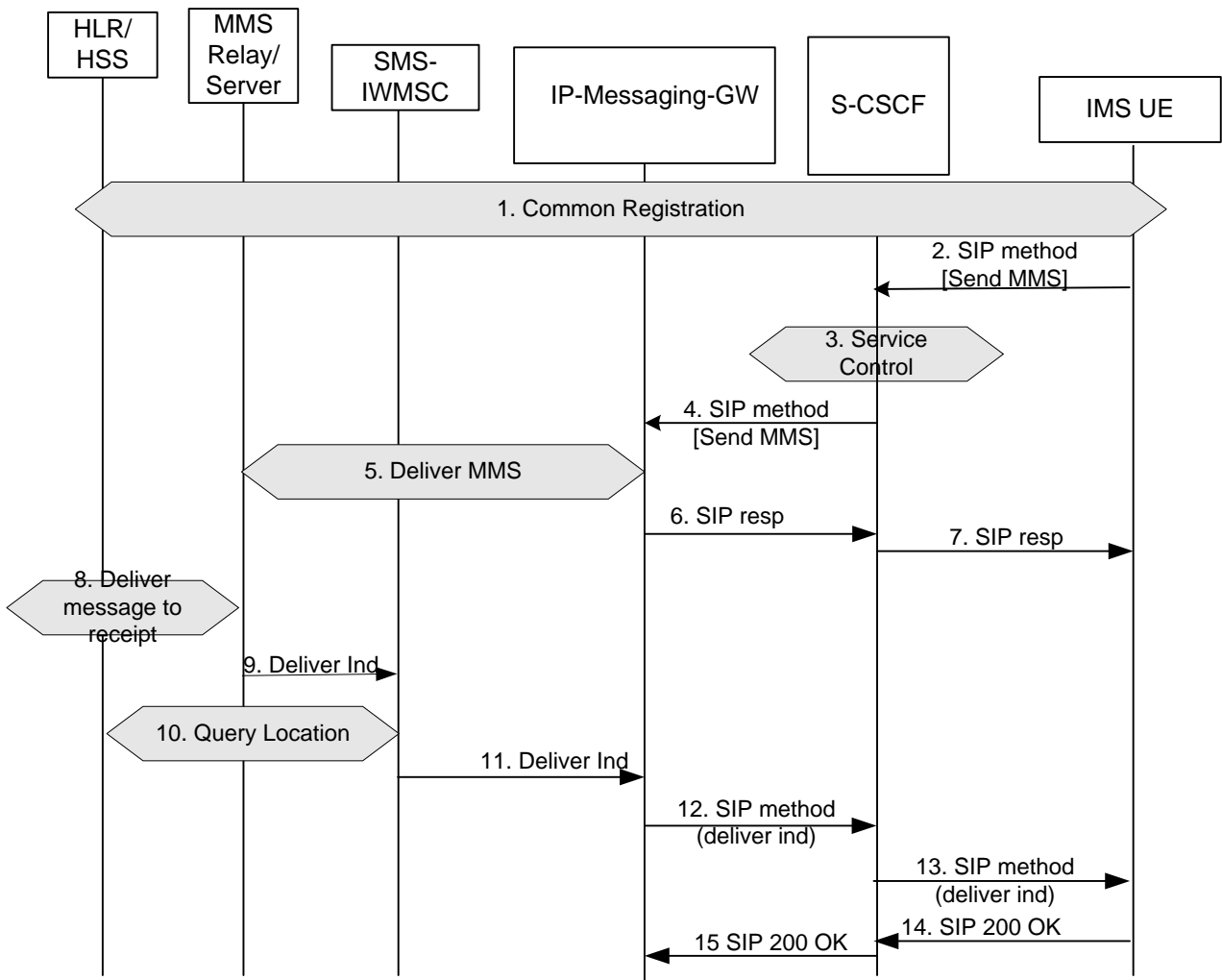

Figure 8.11-1: MMS Origination procedure

- 1) IMS registration procedure.
- 2-4) UE sends MMS over IMS to the IP-Messaging-GW.

- 5) The IP-Messaging-GW sends MMS to terminating UE as defined in 23.140. It is FFS whether the SIP MESSAGE method contains an MMS indication provided by the UE or whether the IP-Message-GW (AS) uses e.g. the MMS service to transport non-text messages.
- 6-7) Ack of the successful sending of the MMS.
- 8-11) In case UE requested delivery indication, a delivery indication is sent to UE via SMS.
- 12-15) Deliver "Deliver ind" SMS via IMS.

8.11.2 MMS Terminating Procedure

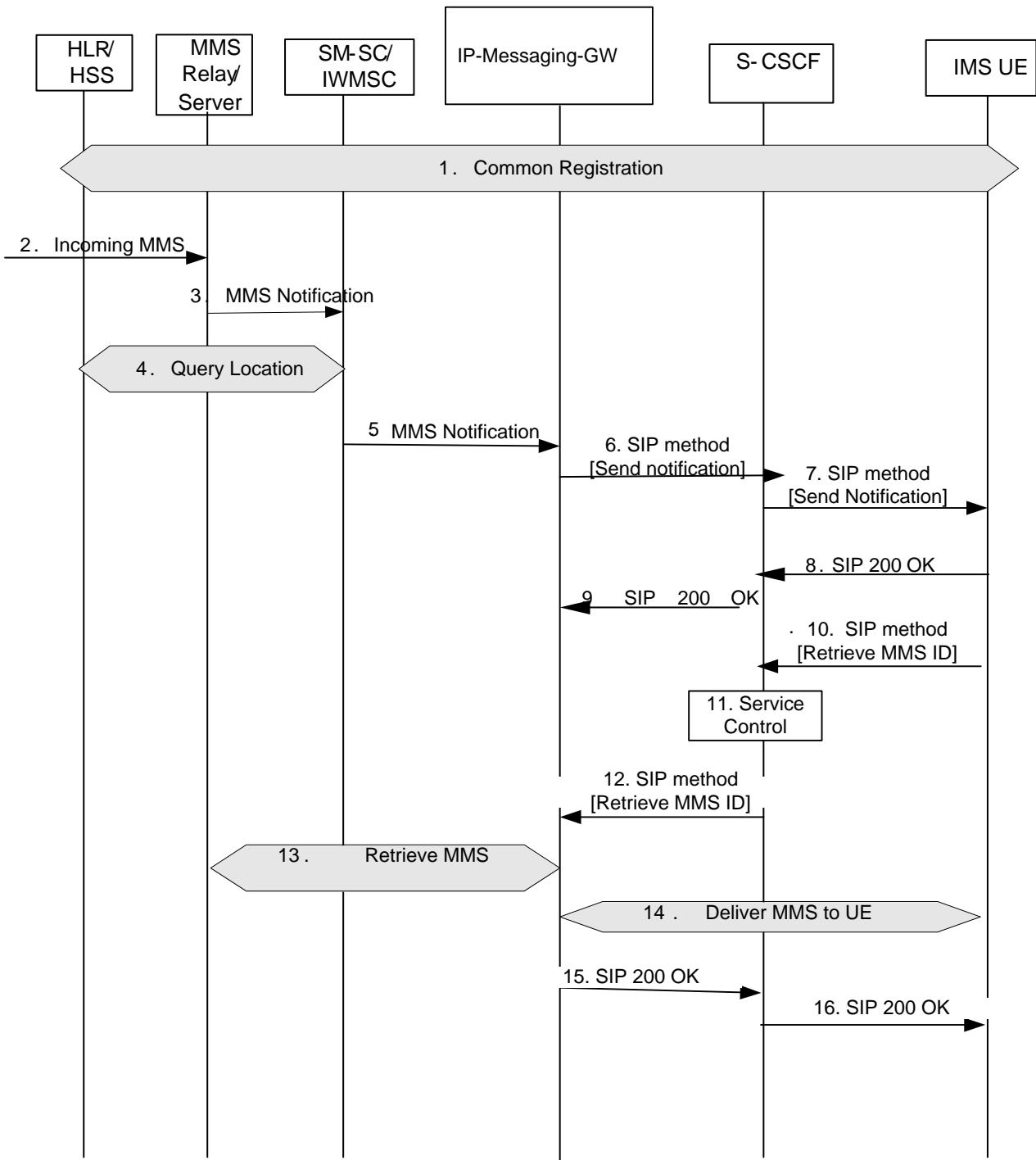

Figure 8.11-2: MMS Terminating procedure

- 1) IMS registration.
- 2-5) An incoming MMS is sent to the UE, and terminating network sends UE the notification using SMS to the IP-Messaging-GW.
- 6-9) IP-Messaging-GW sends MMS Notification to UE with the MMS ID.

- 10-12) UE attempts to retrieve the MMS from the IP-Messaging-GW indicating the MMS ID.
- 13) IP-Messaging-GW retrieves the MMS as defined in TS 23.140.
- 14) IP-Messaging-GW delivers the MMS to the UE. The actual mechanism used is FFS.
- 15-16) SIP 200 OK.

8.11.3 MMS with SIP based Push

8.11.3.1 General

MMS is transported over IP (using protocols such as HTTP and SMTP) with the exception for the case when the Push Enabler is using SMS for bearer and session initiation. However, OMA BAC Push SWG is studying a SIP based Push solution, i.e. when MMS is enhanced with SIP based Push all parts of MMS may be transported over IP.

OMA has not yet decided which IMS enablers to use for Push. It could for example be SIP User Agent capabilities and characteristics in combination with SIP MESSAGE or usage of event handling and SUBSCRIBE/NOTIFY, or other IMS enablers. Consequently, the procedures below will have to be updated once OMA has decided which IMS enablers to use.

The message names between the UE and the MMS Relay/Server and between the UE and the IP-Messaging-GW are taken from TS 23.140 [10].

8.11.3.2 MMS Origination procedure

The sequence diagram in figure 8.11.3-1 gives an example of sending an MMS.

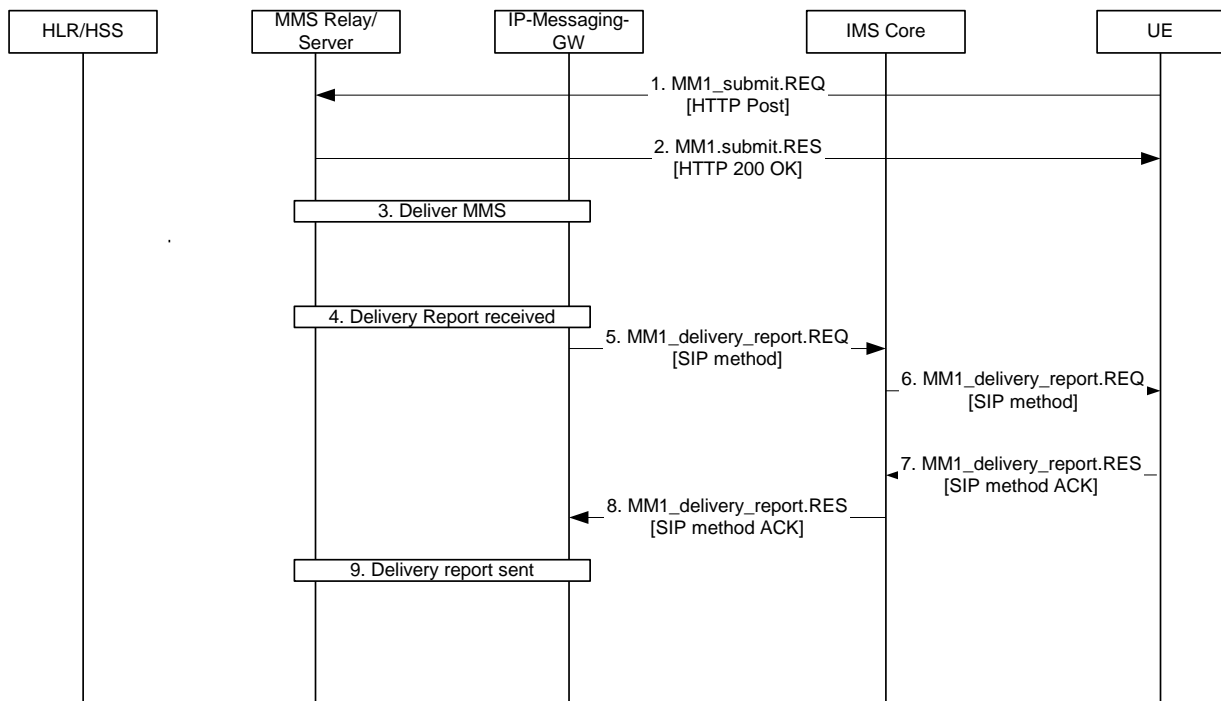

Figure 8.11.3-1: MMS Origination procedure

- 1) The UE sends MMS using HTTP POST.
- 2) The MMS Relay/Server provides the status of the request.
- 3) The MMS Relay/Server and the IP-Messaging-GW deliver the MMS to the terminating network.
- 4) The MMS Relay/Server and the IP-Messaging-GW receives a delivery report.

- 5) The IP-Messaging-GW sends the delivery report in a SIP method to the UE, via IMS Core.
- 6) The IMS Core forwards the SIP method to the UE.
- 7) The UE acknowledge the reception of the delivery report.
- 8) The IMS Core forwards the delivery report acknowledgement.
- 9) The MMS Relay/Server and the IP-Messaging-GW notifies the terminating network.

8.11.3.3 MMS Terminating Procedure

The sequence diagram in figure 8.11.3-2 gives an example of receiving an MMS.

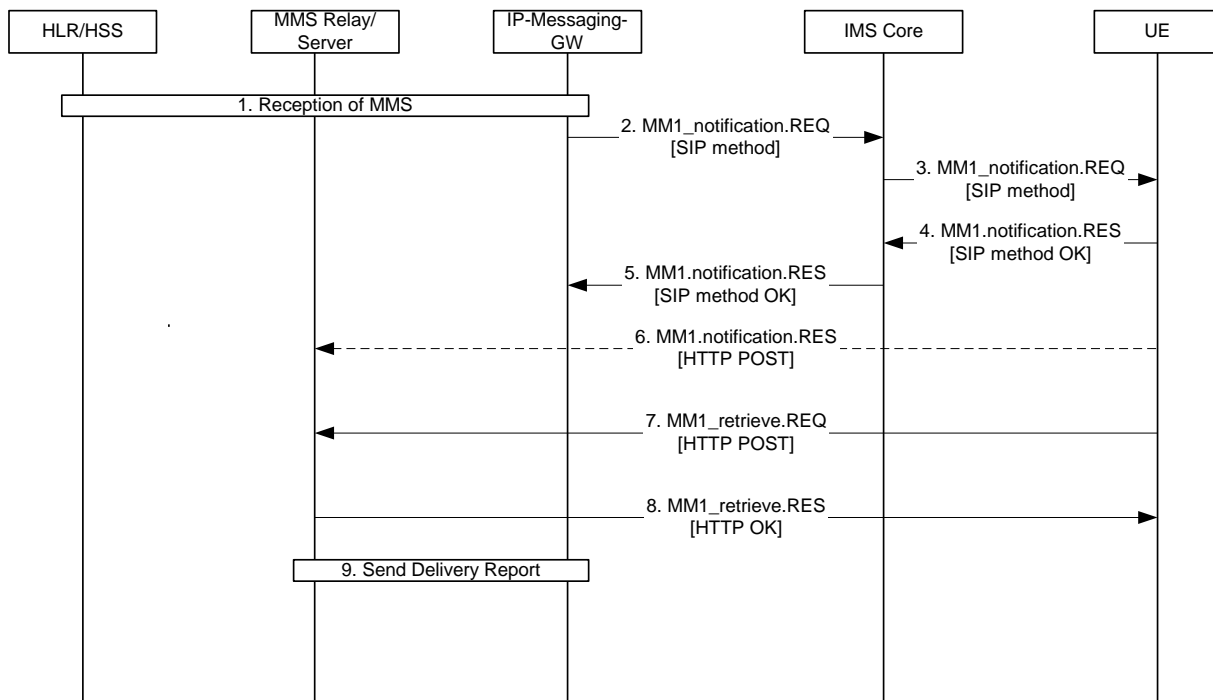

Figure 8.11.3-2: MMS Termination procedure

- 1) The MMS Relay/Server and the IP-Messaging-GW receives an MMS.
- 2) The IP-Messaging-GW notifies the UE that an MMS exist, via IMS Core.
- 3) The IMS Core forwards the notification to the UE.
- 4) The UE acknowledge the reception of the notification.
- 5) The IMS Core forwards the notification acknowledgement.
- 6) The UE acknowledge the reception of the notification. This is currently done with an HTTP POST, but it may be changed to be included in the SIP exchange.
- 7) The UE sends a request to retrieve the MMS content.
- 8) The MMS Relay/Server provides the content.
- 9) The MMS Relay/Server and the IP-Messaging-GW sends a delivery report towards the originating network or UE.

9 Conclusion and recommendations

This Technical Report describes the architecture and high-level stage-2 procedure alternatives for SMS and MMS over generic IP access. To fully exploit and re-use mechanisms that are already standardized, it is recommended to pursue the SIP/IMS based mechanism for SMS/MMS over IP access. In particular, it is recommended to utilize IMS - registration, and IMS Immediate Message capabilities for transparently delivering originating and terminating SMS over IP access (see Sections 8.7-8.10).

For MMS, it is recommended to pursue utilizing SIP-based Push for notification (i.e. SIP would be used whenever SMS is used as transport), whilst continue using HTTP and SMTP for transfer of the MMS itself, as described in Section 8.11.3.

It is assumed that the OMA SIP-based Push work will utilize IMS enablers.

It is proposed to develop an IMS enabler providing IMS based deferred messaging.

Interworking aspects between SMS/MMS and IMS based messaging should be further studied.

Annex A: Change history

Change history							
Date	TSG SA 2#	TSG SA2 Doc.	CR	Rev	Subject/Comment	Old	New
2005-05	SA2#46	-	-	-	Agreed document at SA2#46 email approval:S2-051404	1.1.1	1.2.0
2005-05	SA#28	SP-050349	-	-	Editorial update by MCC for presentation to TSG SA for approval	1.2.0	2.0.0
2005-06	SA#28	SP-050349	-	-	Approved at TSG SA #28 and placed under change control	2.0.0	7.0.0
2005-06	SA#29	SP-050484	0001	-	Correction to flow SMS MT Delivery using SIP/IMS	7.0.0	7.1.0