

3GPP TS 23.507 V8.0.0 (2007-12)

Technical Specification

**3rd Generation Partnership Project;
Technical Specification Group Technical Specification Group
Services and System Aspects;
Telecommunications and Internet Converged Services and
Protocols for Advanced Networking (TISPAN);
Voice Call Continuity (VCC);
Stage 2
[3GPP TS 23.206 Release 7, modified]
(Release 8)**



The present document has been developed within the 3rd Generation Partnership Project (3GPP™) and may be further elaborated for the purposes of 3GPP.

The present document has not been subject to any approval process by the 3GPP Organizational Partners and shall not be implemented. This Specification is provided for future development work within 3GPP only. The Organizational Partners accept no liability for any use of this Specification. Specifications and reports for implementation of the 3GPP™ system should be obtained via the 3GPP Organizational Partners' Publications Offices.

Keywords

UMTS, IMS, speech, stage 2

3GPP

Postal address

3GPP support office address

650 Route des Lucioles - Sophia Antipolis
Valbonne - FRANCE
Tel.: +33 4 92 94 42 00 Fax: +33 4 93 65 47 16

Internet

<http://www.3gpp.org>

Copyright Notification

No part may be reproduced except as authorized by written permission.
The copyright and the foregoing restriction extend to reproduction in all media.

© 2007, 3GPP Organizational Partners (ARIB, ATIS, CCSA, ETSI, TTA, TTC).
All rights reserved.

Contents

Foreword	4
Introduction	4
1 Scope	5
2 References.....	5
Endorsement notice	5
Annex ZA (informative): A possible scenario to adapt 3GPP VCC to multi-operator scenario.....	7
ZA.1 <u>Introduction</u>	7
ZA.2 Definitions, symbols and abbreviations	7
ZA.2.1 Definitions	7
ZA.3 <u>VCC Concepts</u>	7
ZA.3.1 General	7
ZA.3.2 Radio environments	8
ZA.3.3 Domain Selection	8
ZA.3.4 Anchoring in IMS of VCC subscriber calls	8
ZA.3.5 Domain transfer procedures.....	9
ZA.3.6 Regulatory aspects.....	9
ZA.4 <u>Architecture</u>	9
ZA.4.1 Reference Model.....	9
ZA.4.2 VCC entities	11
ZA.4.2.1 VCC application.....	11
ZA.4.2.2 VCC UE.....	11
ZA.4.3 Reference points	12
ZA.4.3.1 DTF – S-CSCF, CSAF – S-CSCF, DSF – S-CSCF reference point (ISC)	12
ZA.4.3.2 CSAF – I-CSCF, DTF – I-CSCF reference point (Ma).....	12
ZA.4.3.3 Functional entity – UPSF HSS reference point.....	12
ZA.4.3.4 gsmSCF – VMSC reference point.....	12
ZA.4.3.5 gsmSCF – HSS reference point	12
ZA.4.3.6 VCC Application – VCC UE reference point (V3).....	12
ZA.6 <u>Security</u>	13
ZA.6.1 General	13
ZA.6.2 IP-CAN Access security.....	13
Annex ZZ (informative): Change history.....	14

Foreword

This Technical Specification (TS) was produced by ETSI Technical Committee Telecommunications and Internet converged Services and Protocols for Advanced Networking (TISPAN) under work item DTS/TISPAN-02051-NGN-R2 and originally intended to be published as ETSI TS 182 007. It was transferred to the 3rd Generation Partnership Project (3GPP) in December 2007.

The contents of the present document are subject to continuing work within the TSG and may change following formal TSG approval. Should the TSG modify the contents of the present document, it will be re-released by the TSG with an identifying change of release date and an increase in version number as follows:

Version x.y.z

where:

- x the first digit:
 - 1 presented to TSG for information;
 - 2 presented to TSG for approval;
 - 3 or greater indicates TSG approved document under change control.
- y the second digit is incremented for all changes of substance, i.e. technical enhancements, corrections, updates, etc.
- z the third digit is incremented when editorial only changes have been incorporated in the document.

Introduction

The present document describes Voice Call Continuity functionalities for TISPAN Release 2. Scope of the work is to endorse the current 3GPP Release 7 stage 2 solution of VCC (described in the TS 23 206).

1 Scope

The present document provides the ETSI TISPAN endorsement of 3GPP TS.23.206 [3] " Voice Call Continuity (VCC) between Circuit Switched (CS) and IP Multimedia Subsystem (IMS); Stage 2: Release 7".

The current VCC solution explained in the TS.23.206 is essentially defined for a core IMS provider that is a mobile operator (that has also CS domain). In Informative Annex ZA there is a possible scenario how the solution can be extended to a generic IMS operator (e.g. when fixed network operator and CS mobile network operator are separate organisations).

2 References

The following documents contain provisions which, through reference in this text, constitute provisions of the present document.

- References are either specific (identified by date of publication, edition number, version number, etc.) or non-specific.
- For a specific reference, subsequent revisions do not apply.
- For a non-specific reference, the latest version applies. In the case of a reference to a 3GPP document (including a GSM document), a non-specific reference implicitly refers to the latest version of that document *in the same Release as the present document*.

Referenced documents which are not found to be publicly available in the expected location might be found at <http://docbox.etsi.org/Reference>.

- [i] ETSI TR 181 011: "Telecommunications and Internet Converged Services and Protocols for Advanced Networking (TISPAN); Fixed Mobile Convergence; Requirements Analysis".
- [ii] ETSI TS 181 013: "Telecommunications and Internet Converged Services and Protocols for Advanced Networking (TISPAN); Services and Capabilities Requirements".
- [iii] 3GPP TS 23.206: " Voice Call Continuity (VCC) between Circuit Switched (CS) and IP Multimedia Subsystem (IMS); Stage 2 (Release 7)."
- [iv] ETSI ES 282 007: "Telecommunications and Internet Converged Services and Protocols for Advanced Networks (TISPAN) IP Multimedia Subsystem (IMS) Functional Architecture".
- [v] ETSI TS 180 000: "Telecommunications and Internet Converged Services and Protocols for Advanced Networks (TISPAN); NGN Terminology".
- [vi] ETSI TS 282 004: "NGN Functional Architecture; Network Attachment Subsystem".
- [vii] ETSI TS 183 019: "Telecommunications and Internet converged Services and Protocols for Advanced Networking (TISPAN); Interface protocol definitions for network access through xDSL and WLAN access networks".

Endorsement notice

The present document, in conjunction with 3GPP TS 23.206 [iii], provides the specifications for the stage 2 of the Voice Call Continuity for NGNs. ETSI TR 181 011 [i] and ETSI TS 181 013 [ii] contain service descriptions.

The elements of 3GPP TS 23.206 [iii] apply, with the following modifications.

NOTE: New or modified text is underlined in the following subclauses.

2. References

The references [iii] should be replaced as shown below:

Reference in TS 23.206 [iii]	Modified reference
[6] 3GPP TS 33.203: "Access security for IP based services".	TS 187 003 "Telecommunications and Internet converged Services and Protocols for Advanced Networking (TISPAN); Security Architecture"
[9] 3GPP TS 22.173: "IP Multimedia Core Network Subsystem (IMS) Multimedia Telephony Service and supplementary services; Stage 1".	TS 181 002 "Telecommunications and Internet converged Services and Protocols for Advanced Networking (TISPAN); Requirements for Multimedia Telephony with PSTN-ISDN Simulation Services"
[11] 3GPP TS 23.002: "Network Architecture"	TS 282 007: " Telecommunications and Internet converged Services and Protocols for Advanced Networking (TISPAN); NGN IMS architecture"
[13] 3GPP TS 23.167: "IP Multimedia Subsystem (IMS) emergency sessions"	TS 182 009 "Telecommunications and Internet converged Services and Protocols for Advanced Networking (TISPAN); NGN Architecture to support emergency communication from citizen to authority"

3 Definitions, symbols and abbreviations

Endorsed with changes.

3.1 Definitions

Replace items in [iii] as follows:

- "HSS" with "UPSF"

6 Information flows and procedures

The text in clause 6 of [iii] applies, with the following modifications.

6.5.2 Supplementary services behaviour

The text in clause 6.5.2 of [iii] applies.

Add in the end of 6.5.2 of [iii] the following two new sub clauses:

6.5.2.7 IMS: Explicit call transfer (ECT), CS: Call Transfer/ECT

There is no impact on the ECT service when remaining in a particular domain. It is not possible to perform ECT and Domain Transfer in parallel.

6.5.2.7 IMS: Call Completion on Busy Subscriber (CCBS), CS: CCBS

There is no impact on the CCBS service when remaining in a particular domain. It may not be possible to recall the originating VCC user in a different domain than the one in which the CCBS service was originally invoked.

Annex ZA (informative): A possible scenario to adapt 3GPP VCC to multi-operator scenario

ZA.1 Introduction

The present annex defines additional concepts of VCC service provisioning in order to support **VCC multi-operator scenario** where IMS and CS domain belong to different operators; i.e. when the user's IMS services and the user's CS services are under the control of different home operators.

For the purposes of the present annex, the concepts given in TS 23.206 [iii] and the ones defined in the main body of this specification are still to be applied.

ZA.2 Definitions, symbols and abbreviations

The text in clause 3 of [iii] applies, with the following modifications.

ZA.2.1 Definitions

The text in clause 3.1 of [iii] applies.

Moreover the following definitions apply:

VCC single-operator scenario: VCC scenario where IMS and CS domain belong to the same operator

VCC multi-operator scenario: VCC scenario where IMS and CS domain belong to different operators; i.e. when the user's IMS services and the user's CS services are under the control of different home operators.

ZA.3 VCC Concepts

ZA.3.1 General

The description enhances the VCC general concepts specified in subclause 4.1 of [iii].

Two operators providing CS and IMS access respectively may co-operate to provide VCC together for their subscribers. 3GPP VCC can be applied in this kind of scenario under appropriate conditions. However there are a number of issues to be agreed between the parties starting from the ownership of the subscriber (and SIM card). One thing to agree is if the subscriber can have IMS services also in the CS operator network. Two simultaneous or just different types of IMS registrations may not be supported by terminals.

The HSS depicted in the VCC architecture can be split into HLR and IMS part of HSS. CS operator manages the CS subscription and the HLR data and is responsible for the related authentication. IMS operator manages the IMS subscription and the IMS part of HSS as well as authentication to IMS. The operators may agree that MAP protocol is used towards HLR e.g. to query the user status.

CAMEL control is made by the CS operator as agreed with the IMS operator to route originating calls to IMS for anchoring and chosen services. The operators need to agree on the way the address information is carried so that CS Adaptation function of the VCC Application is able to restore the originally provided called party address. Otherwise

inter-operator interface would be needed between CAMEL, gsmSCF and VCC Application. No change is needed to TS 23.206.

The applied subscriber addressing and routing scheme shall be designed. It may be required to use two different public addresses for CS and IMS respectively. It should be decided if single address is wished and if that is the case, which operator holds those addresses i.e. whether IMS or CS operator network gets the incoming traffic. All VCC enabled calls shall be routed via IMS operator network even if they would first enter the CS operator network. VCC Domain Selection Function in the IMS operator network decides if the IMS or CS domain is used for the terminating call. VCC Application shall be aware of subscriber's addresses in CS and IMS.

If single subscriber address is wished to be shown as calling party address, a particular service is needed in IMS operator network to achieve this. This is outside the scope of VCC. It should be noted that the regulatory requirements may prohibit changing the actual calling party address carried in signalling.

VCC Application may contain different type of policies regarding CS and IMS use but all details of those are out of scope of standardization. VCC Application may store the policy to the terminal by device management means as specified for 3GPP VCC.

The VCC service model is distributed and e.g. call forwarding services may be provided in both CS and in IMS. These settings are separate by default in VCC. If any synchronization of supplementary service settings is wished, an inter-operator interface is required in this deployment case.

If domain transfers are required only to one direction e.g. IMS to CS, appropriate policy may be used to e.g. skip routing CS originated calls via IMS. However if single number service should be required, then the CS operator service (e.g. IN/CAMEL) shall cater for it.

Charging is generated on both CS and IMS operator networks for the subscriber. The common charging scheme shall be developed by the operators. One possible way is to centralize charging to the IMS operator and then the CS operator records only the connection time for inter-operator charging purposes.

ZA.3.2 Radio environments

The description enhances the VCC concepts specified in subclause 4.2 of [iii].
Out of scope for TISPAN.

ZA.3.3 Domain Selection

The text in subclause 4.3 of [iii] applies without changes.

ZA.3.4 Anchoring in IMS of VCC subscriber calls

The text in subclause 4.4 of [iii] applies, with the following modifications.

Anchoring of IMS multimedia telephony sessions are controlled by the operator policy. The default policy is all IMS multimedia telephony sessions originated by VCC subscribers in the IMS are anchored in the IMS in order to facilitate domain transfer of the voice component to the CS domain.

Voice calls originated by VCC subscribers in the CS domain may or may not be anchored in the IMS, subject to operator policy. A CS originated call has to be anchored in IMS to allow domain transfer to occur.

Voice calls which IMS cannot route are not anchored in IMS. Considering a voice call originated by a roaming VCC subscriber, using a called party number not in the international format and for which the home IMS network has no means to translate (e.g. a local number), IMS has no way to determine the intended local destination and cannot anchor the call. CAMEL processing in the CS domain may solve this problem by translating dialled numbers into the international number format according the following guidelines:

- If the VCC UE is in the Home Network HPLMN, no translation is required, the call is anchored.
- If the VCC UE is not in the Home Network HPLMN but located in a Visited Network VPLMN with known translation rules for that number, translation is performed and the call is anchored.

- If the VCC UE is not in the Home Network~~HPLMN~~ but located in a Visited Network~~VPLMN~~ with no known translation rules for that number, no translation is performed and the call is not anchored.

If a call from a VCC subscriber is not anchored in the IMS, domain transfer is not supported for that call.

Priority call handling is not preserved if a priority call, originated by VCC subscribers in the CS domain, is anchored in IMS.

NOTE: See TR 22.952 [7] for information on priority subscriber and priority call handling.

ZA.3.5 Domain transfer procedures

The text in subclause 4.5 of [iii] applies without changes.

ZA.3.6 Regulatory aspects

The text in subclause 4.6 of [iii] applies without changes.

ZA.4 Architecture

The text in clause 5 of [iii] applies, with the following modifications.

ZA.4.1 Reference Model

Figure ZA.15.1 depicts the VCC reference architecture.

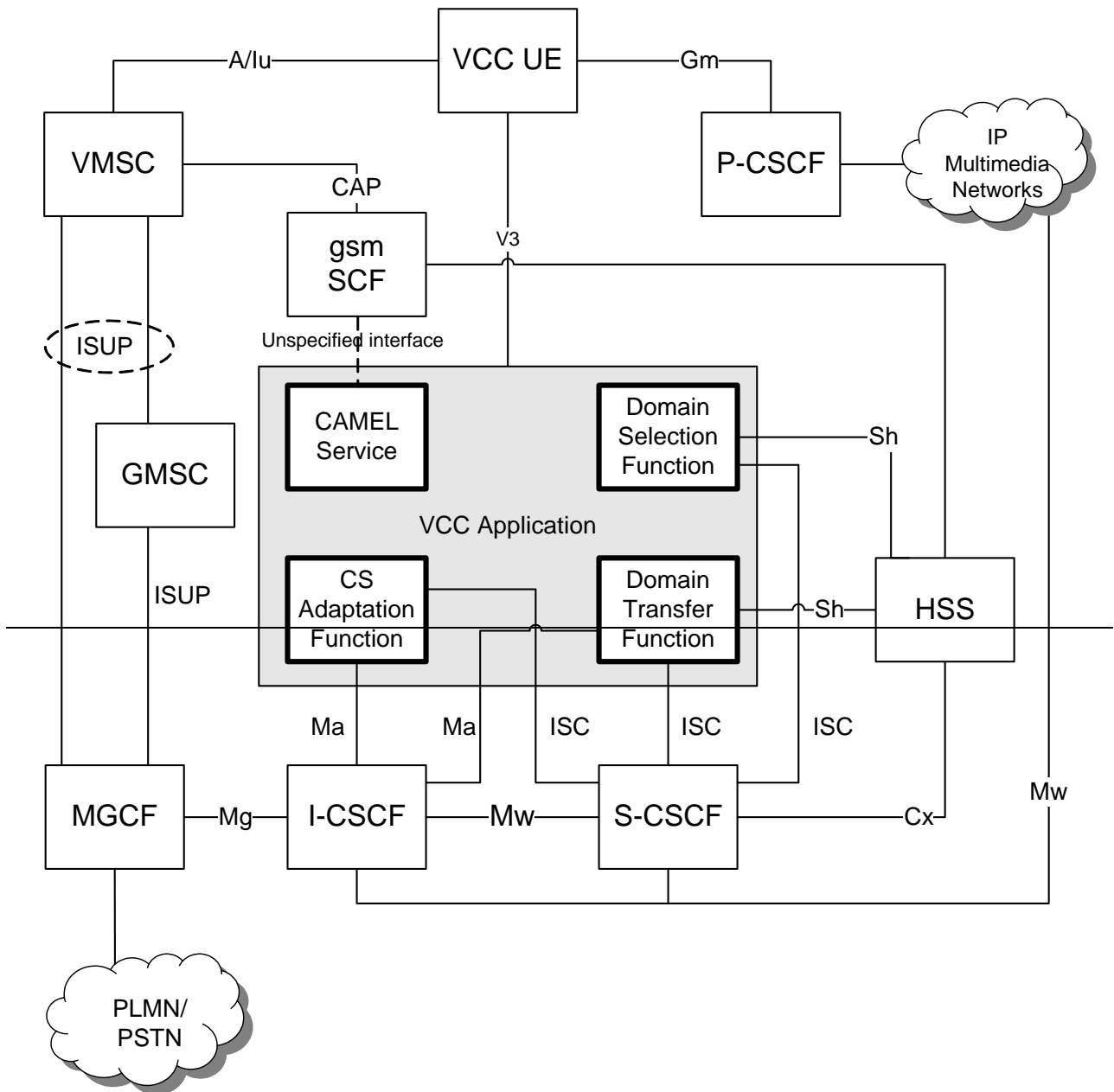

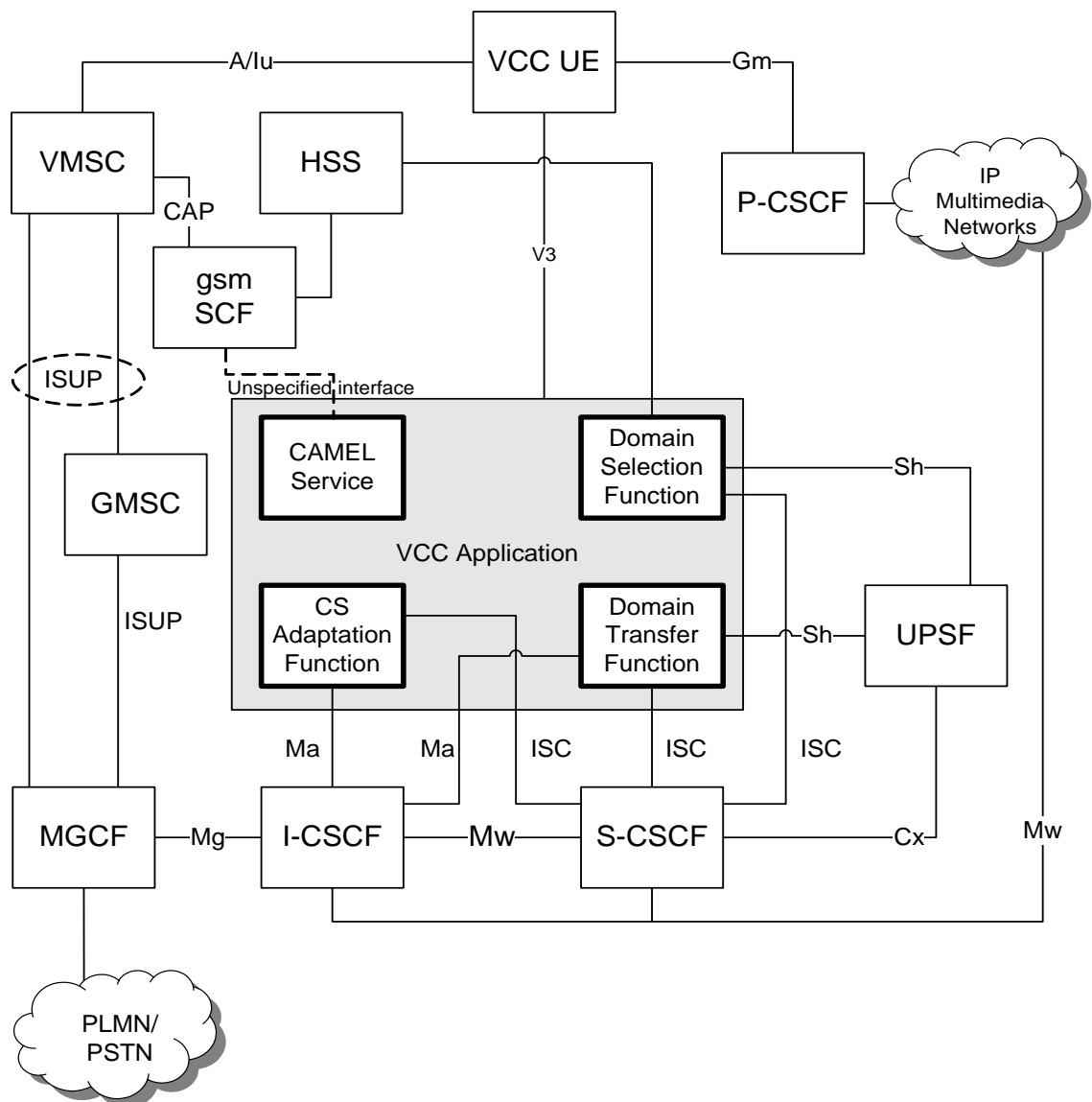

NOTE: Not all standard GSM interfaces are depicted in the architecture. Connection between the elements (VMSC, GMSC, MGCF) may be via a transit network. CS domain termination may bypass the GMSC.

Figure ZA.15.4: VCC Reference Architecture for multi-operator scenario

ZA.4.2 VCC entities

ZA.4.2.1 VCC application

The text in subclause 5.3.1 of [iii] applies without changes.

ZA.4.2.2 VCC UE

The VCC UE is a VCC capable User Equipment with an active VCC subscription. It supports voice over both IMS and CS domains. The VCC UE performs the following functions: -

- Stores and applies domain selection policies for both originating calls and Domain Transfers.

- Selects which domain to use for originating calls; it does so based on domain selection policies.
- Communicates the user preferences in order to indicate which domain is preferred for terminating calls.
- Applies the received VCC operator policy prior to process VCC call request (e.g. Call origination, Domain Transfer request).
- Stores VDN/VDI for domain transfer execution.
- Allows the stored VDN/VDI values to be updated.

NOTE: TISPAN requirements should be:

- supports ISIM/USIM/SIM

- authenticates with NGN network when roams into any access belonging to that network

ZA.4.3 Reference points

ZA.4.3.1 DTF – S-CSCF, CSAF – S-CSCF, DSF – S-CSCF reference point (ISC)

The ISC reference point between Serving CSCF and the Application Servers is described in [ES 282 007 \[iv\]](#) ~~TS 23.002 [11]~~.

ZA.4.3.2 CSAF – I-CSCF, DTF – I-CSCF reference point (Ma)

This reference point may be used by the CSAF to route messages to the DTF function via the Ma reference point. The Ma reference point between Interrogating CSCF and the Application Servers is described in [ES 282 007 \[iv\]](#) ~~TS 23.002 [11]~~.

ZA.4.3.3 Functional entity – ~~UPS~~UPSF~~HSS~~ reference point

This reference point is used by the functional entities (DTF, CSAF, DSF) to retrieve information from the ~~HSS-UPS~~UPS~~F of the Core IMS provider~~. This reference point includes Sh; Sh is found between the Application Servers and the ~~HSS-UPS~~UPS and is described in [ES 282 007 \[iv\]](#) ~~TS 23.002 [11]~~.

ZA.4.3.4 gsmSCF – VMSC reference point

This reference point is used by the gsmSCF to provide routing of CS origination calls and CS legs established for Domain Transfer to CS. This reference point uses the gsmSCF to gsmSSF interface as specified in TS 23.078 [4]. The information from the trigger messages are used on the unspecified interface to the CAMEL Service.

ZA.4.3.5 gsmSCF – HSS reference point

This interface is used by the gsmSCF to request information from the HLR. The reference point between the gsmSCF and the HSS of the CS provider is described in TS 23.078 [4].

ZA.4.3.6 VCC Application – VCC UE reference point (V3)

V3 is a reference point between VCC UE and the VCC Application.

This reference point may be realized by using Ut interface as described in [ES 282 007 \[iv\]](#).

ZA.4.3.7 DSF – HSS reference point

This reference point is used by the DSF to retrieve information from the HLR of the CS provider. MAP implementation option shall be used for this reference point.

ZA.6 Security

The text in clause 7 of [iii] applies, with the additional elements described in the present subclause.

ZA.6.1 General

There are no impacts on existing security mechanisms for the CS Domain, other IP-CAN domain or for IMS as a result of Domain Transfers.

ZA.6.2 IP-CAN Access security

Note: For TISpan-NGN access authentication is described in [vi] and [vii].

Annex ZZ (informative): Change history

Change history							
Date	TSG #	TSG Doc.	CR	Rev	Subject/Comment	Old	New
2007-03					draft ETSI TS 102 007 ToC and scope to TISPAN#13bis		0.0.1
2007-04					draft ETSI TS 102 007 Proposed output draft of TISPAN#13bis		0.1.0
2007-05					draft ETSI TS 102 007 Output draft of TISPAN#13ter. Added agreed text coming from 13tTD340r2 and 13tTD462r2		0.2.0
2007-06					draft ETSI TS 102 007 Output draft of TISPAN#14bis. Added agreed text coming from 14bTD347		0.3.0
2007-09					draft ETSI TS 102 007 Output draft of TISPAN#14ter. Proposed version for WG Approval coming from 14bTD399r1		0.3.1
2007-12	SP-38	SP-070936			Conversion to 3GPP format, no technical change		1.0.0
2007-12	SP-38				Approved and frozen	1.0.0	8.0.0