

# 3GPP TS 23.205 V11.0.0 (2011-09)

---

*Technical Specification*

**3rd Generation Partnership Project;  
Technical Specification Group Core Network and Terminals;  
Bearer-independent circuit-switched core network;  
Stage 2  
(Release 11)**



The present document has been developed within the 3<sup>rd</sup> Generation Partnership Project (3GPP™) and may be further elaborated for the purposes of 3GPP. The present document has not been subject to any approval process by the 3GPP Organizational Partners and shall not be implemented. This Specification is provided for future development work within 3GPP only. The Organizational Partners accept no liability for any use of this Specification. Specifications and reports for implementation of the 3GPP™ system should be obtained via the 3GPP Organizational Partners' Publications Offices.

---

Keywords

---

LTE, UMTS, network, circuit mode

**3GPP**

Postal address

---

3GPP support office address

---

650 Route des Lucioles - Sophia Antipolis  
Valbonne - FRANCE  
Tel.: +33 4 92 94 42 00 Fax: +33 4 93 65 47 16

Internet

---

<http://www.3gpp.org>

---

**Copyright Notification**

No part may be reproduced except as authorized by written permission.  
The copyright and the foregoing restriction extend to reproduction in all media.

© 2011, 3GPP Organizational Partners (ARIB, ATIS, CCSA, ETSI, TTA, TTC).  
All rights reserved.

UMTS™ is a Trade Mark of ETSI registered for the benefit of its members  
3GPP™ is a Trade Mark of ETSI registered for the benefit of its Members and of the 3GPP Organizational Partners  
LTE™ is a Trade Mark of ETSI currently being registered for the benefit of its Members and of the 3GPP Organizational Partners  
GSM® and the GSM logo are registered and owned by the GSM Association

# Contents

Foreword .....	15
1 Scope .....	16
2 References.....	16
3 Symbols and abbreviations .....	18
3.1 Symbols.....	18
3.2 Abbreviations.....	18
3.3 Definitions .....	19
4 Main Concepts.....	19
4.1 General .....	19
4.2 Bearer-Independent Call Control.....	19
4.3 H.248/MEGACO .....	20
5 General Circuit Switched Core Network Domain Architecture .....	20
5.1 Logical Architecture .....	20
5.1.1 CS Core Network Nodes.....	20
5.1.1.1 MSC Server.....	20
5.1.1.2 GMSC Server .....	20
5.1.1.3 Media Gateway .....	20
5.1.2 CS Core Network Interfaces and Reference Points.....	21
5.1.2.1 Mc Interface.....	21
5.1.2.2 Nc Interface.....	21
5.1.2.3 Nb Interface .....	21
5.2 Network Interworking .....	21
5.2.1 Interworking on the Nc Reference Point.....	21
5.2.2 Interworking on the Nb Reference Point.....	21
6 Call Establishment .....	21
6.1 Basic Mobile Originating Call .....	21
6.1.1 Forward bearer establishment .....	21
6.1.1.1 MGW selection .....	21
6.1.1.2 Initial addressing.....	22
6.1.1.3 Network side bearer establishment .....	22
6.1.1.4 Access bearer assignment.....	22
6.1.1.5 Framing protocol initialisation .....	22
6.1.1.6 Confirmation of bearer establishment .....	22
6.1.1.7 Through-Connection .....	23
6.1.1.8 Interworking function.....	23
6.1.1.9 Codec handling.....	23
6.1.1.10 Voice Processing function.....	23
6.1.1.11 Failure handling in MSC server .....	23
6.1.1.12 Example .....	23
6.1.2 Backward bearer establishment .....	26
6.1.2.1 MGW selection .....	26
6.1.2.2 Network side bearer establishment .....	26
6.1.2.3 Initial addressing.....	26
6.1.2.4 Access bearer assignment.....	27
6.1.2.5 Framing protocol initialisation .....	27
6.1.2.6 Confirmation of bearer establishment .....	27
6.1.2.7 Through-Connection .....	27
6.1.2.8 Interworking function.....	27
6.1.2.9 Codec handling.....	28
6.1.2.10 Voice Processing function.....	28
6.1.2.11 Failure handling in MSC server .....	28
6.1.2.12 Example .....	28
6.1.3 Originating Call Establishment For Iu Interface on IP .....	30

6.1.4	Forward bearer establishment with Trace Session Activation .....	31
6.1.4.1	Trace activation .....	31
6.1.4.2	Example .....	32
6.1.5	Originating Call Establishment for A interface over IP .....	34
6.2	Basic Mobile Terminating Call .....	35
6.2.1	Forward bearer establishment .....	35
6.2.1.1	GMSC server .....	35
6.2.1.1.1	MGW selection .....	35
6.2.1.1.2	Initial addressing.....	36
6.2.1.1.3	Outgoing side bearer establishment.....	36
6.2.1.1.4	Incoming side bearer establishment.....	36
6.2.1.1.5	Framing protocol initialisation .....	36
6.2.1.1.6	Through-Connection .....	36
6.2.1.1.7	Confirmation of bearer establishment .....	36
6.2.1.1.8	Voice Processing function.....	37
6.2.1.1.9	Failure handling in GMSC server .....	37
6.2.1.2	MSC server .....	37
6.2.1.2.1	Paging .....	37
6.2.1.2.2	Call setup.....	37
6.2.1.2.3	MGW selection .....	37
6.2.1.2.4	Network side bearer establishment .....	37
6.2.1.2.5	Access bearer assignment.....	37
6.2.1.2.6	Framing protocol initialisation .....	38
6.2.1.2.7	Called party alerting .....	38
6.2.1.2.8	Called party answer .....	38
6.2.1.2.9	Through-Connection .....	38
6.2.1.2.10	Interworking function.....	39
6.2.1.2.11	Codec handling.....	39
6.2.1.2.12	Voice Processing function.....	39
6.2.1.2.13	Failure handling in MSC server .....	39
6.2.1.2.14	Example .....	39
6.2.2	Backward bearer establishment .....	42
6.2.2.1	GMSC server .....	42
6.2.2.1.1	MGW selection .....	42
6.2.2.1.2	Outgoing side bearer establishment.....	42
6.2.2.1.3	Initial addressing.....	42
6.2.2.1.4	Incoming side bearer establishment.....	42
6.2.2.1.5	Framing protocol initialisation .....	42
6.2.2.1.6	Through-Connection .....	43
6.2.2.1.7	Confirmation of bearer establishment .....	43
6.2.2.1.8	Voice Processing function.....	43
6.2.2.1.9	Failure handling in GMSC server .....	43
6.2.2.2	MSC server .....	43
6.2.2.2.1	Paging .....	43
6.2.2.2.2	Call setup.....	43
6.2.2.2.3	MGW selection .....	44
6.2.2.2.3	Network side bearer establishment .....	44
6.2.2.2.4	Access bearer assignment.....	44
6.2.2.2.5	Framing protocol initialisation .....	44
6.2.2.2.6	Called party alerting .....	45
6.2.2.2.7	Called party answer .....	45
6.2.2.2.8	Through-Connection .....	45
6.2.2.2.9	Interworking function.....	45
6.2.2.2.10	Codec handling.....	45
6.2.2.2.11	Voice Processing function.....	45
6.2.2.2.12	Failure handling in MSC server .....	45
6.2.2.2.13	Example .....	45
6.2.3	Terminating Call Establishment For Iu Interface on IP .....	49
6.2.4	Terminating Call Establishment For A Interface over IP .....	51
7	Call Clearing .....	51
7.1	Network Initiated .....	52

7.1.1	GMSC server .....	52
7.1.1.1	Call clearing from the incoming side .....	52
7.1.1.2	Call clearing to the outgoing side.....	52
7.1.2	MSC server.....	52
7.1.2.1	Call clearing from the network side.....	52
7.1.2.2	Call clearing to the UE.....	52
7.1.2.3	Example .....	53
7.2	User Initiated .....	54
7.2.1	Void .....	55
7.2.2	MSC server.....	55
7.2.2.1	all clearing from the UE .....	55
7.2.2.2	Call clearing to the network side.....	55
7.2.2.3	Example .....	55
7.3	(G)MSC server Initiated .....	56
7.3.1	GMSC server .....	56
7.3.1.1	Call clearing to the destination side.....	56
7.3.1.2	Call clearing to the originating side .....	56
7.3.2	MSC server.....	57
7.3.2.1	Call clearing to the UE.....	57
7.3.2.2	Call clearing to the network side.....	57
7.3.2.3	Example .....	57
7.4	MGW Initiated .....	59
7.4.1	GMSC server .....	59
7.4.1.1	Bearer released on the destination side .....	59
7.4.1.2	Bearer released on the originating side .....	59
7.4.2	MSC server.....	59
7.4.2.1	Bearer released on the access side.....	59
7.4.2.2	Bearer released on the network side.....	59
7.4.2.3	Example .....	59
7.5	Call Clearing for Iu Interface on IP .....	61
8	Handover/Relocation.....	63
8.1	UMTS to UMTS .....	63
8.1.1	Intra-MSC SRNS/SBSS Relocation.....	63
8.1.1.1	Relocation Required .....	64
8.1.1.2	Relocation Command/Relocation Detect.....	64
8.1.1.3	Relocation Complete .....	64
8.1.1.4	Interworking function.....	64
8.1.1.5	Codec handling.....	64
8.1.1.6	Voice Processing function.....	64
8.1.1.7	Handling of multiple bearers (multicall).....	64
8.1.1.8	Failure Handling in MSC server .....	64
8.1.1.9	Example .....	64
8.1.2	Basic Inter-MSC SRNS/SBSS Relocation.....	67
8.1.2.1	MSC-A/MGW-A .....	67
8.1.2.1.1	Relocation Required .....	67
8.1.2.1.2	Bearer establishment between MGW-A and MGW-B.....	67
8.1.2.1.3	Relocation Command/Relocation Detect.....	67
8.1.2.1.4	Relocation Complete .....	67
8.1.2.1.5	Interworking function.....	67
8.1.2.1.6	Codec handling.....	67
8.1.2.1.7	Voice Processing function.....	67
8.1.2.1.8	Handling of multiple bearers (multicall).....	68
8.1.2.1.9	Failure Handling in MSC server .....	68
8.1.2.2	MSC-B/MGW-B.....	68
8.1.2.2.1	MGW selection .....	68
8.1.2.2.2	Bearer establishment towards RNC-B .....	68
8.1.2.2.3	Bearer establishment between MGW-A and MGW-B.....	68
8.1.2.2.4	Codec handling.....	68
8.1.2.2.5	Voice Processing function.....	68
8.1.2.2.6	Handling of multiple bearers (multicall).....	68
8.1.2.2.7	Failure Handling in MSC server .....	68

8.1.2.2.8	Example .....	69
8.1.3	Subsequent Inter-MSC SRNS/SBSS Relocation back to the Anchor MSC .....	71
8.1.3.1	MSC-A/MGW-A .....	71
8.1.3.1.1	Relocation Request.....	71
8.1.3.1.2	Relocation Command/Relocation Detect.....	71
8.1.3.1.3	Relocation Complete .....	72
8.1.3.1.4	Interworking function.....	72
8.1.3.1.5	Codec handling.....	72
8.1.3.1.6	Voice Processing function.....	72
8.1.3.1.7	Handling of multiple bearers (multicall).....	72
8.1.3.1.8	Failure Handling in MSC server .....	72
8.1.3.2	MSC-B/MGW-B.....	72
8.1.3.2.1	Relocation Required .....	72
8.1.3.2.2	Relocation Complete .....	72
8.1.3.2.3	Release of bearer towards MGW-A .....	72
8.1.3.2.4	Handling of multiple bearers (multicall).....	73
8.1.3.2.5	Example .....	73
8.1.4	Subsequent Inter-MSC SRNS/SBSS Relocation to a third MSC .....	75
8.1.5	SRNS/SBSS Relocation with Iu on IP .....	75
8.1.6	Intra-MSC enhanced SRNS Relocation .....	76
8.1.6.1	Introduction.....	76
8.1.6.2	Enhanced Relocation Complete Request.....	76
8.1.6.3	Enhanced Relocation Complete Confirm .....	77
8.1.6.4	Interworking function.....	77
8.1.6.5	Codec handling.....	77
8.1.6.6	Voice Processing function.....	77
8.1.6.7	Handling of multiple bearers (multicall).....	77
8.1.6.8	Failure Handling in MSC server .....	77
8.1.6.9	Example .....	77
8.1.7	Intra-MSC enhanced SRNS Relocation with Iu on IP .....	79
8.2	UMTS to GSM .....	80
8.2.1	Intra-MSC UMTS to GSM Handover .....	80
8.2.1.1	Relocation Required .....	80
8.2.1.2	Handover Request Acknowledge.....	81
8.2.1.3	Relocation Command/Handover Detect .....	81
8.2.1.4	Handover Complete .....	81
8.2.1.5	Interworking function.....	81
8.2.1.6	Voice Processing function.....	81
8.2.1.7	Handling of multiple bearers (multicall).....	81
8.2.1.8	Failure Handling in MSC server .....	81
8.2.1.9	Example .....	81
8.2.1.10	Intra-MSC UMTS to GSM Handover for A interface over IP.....	84
8.2.2	Basic Inter-MSC UMTS to GSM Handover .....	85
8.2.2.1	MSC-A/ MGW-A .....	85
8.2.2.1.1	Bearer establishment between MGW-A and MGW-B.....	85
8.2.2.1.2	Relocation Command/Handover Detect .....	85
8.2.2.1.3	Handover Complete .....	86
8.2.2.1.4	Interworking function.....	86
8.2.2.1.5	Voice Processing function.....	86
8.2.2.1.6	Handling of multiple bearers (multicall).....	86
8.2.2.1.7	Failure Handling in MSC server .....	86
8.2.2.2	MSC-B/MGW-B.....	86
8.2.2.2.1	MGW selection .....	86
8.2.2.2.2	Bearer establishment towards BSC-B .....	86
8.2.2.2.3	Bearer establishment between MGW-A and MGW-B.....	86
8.2.2.2.4	Voice Processing function.....	86
8.2.2.2.5	Failure Handling in MSC server .....	86
8.2.2.2.6	Example .....	87
8.2.2.3	Basic Inter-MSC UMTS to GSM Handover for A Interface over IP .....	89
8.2.3	Subsequent Inter-MSC UMTS to GSM Handover back to the Anchor MSC .....	90
8.2.3.1	MSC-A.....	90
8.2.3.1.1	Handover Request.....	90

8.2.3.1.2	Handover Request Acknowledge.....	91
8.2.3.1.3	Relocation Command/Handover Detect .....	91
8.2.3.1.4	Handover Complete .....	91
8.2.3.1.5	Interworking function.....	91
8.2.3.1.6	Voice Processing function.....	91
8.2.3.1.7	Handling of multiple bearers (multicall).....	91
8.2.3.1.8	Failure Handling in MSC server .....	91
8.2.3.2	MSC-B.....	91
8.2.3.2.1	Handover Complete .....	91
8.2.3.2.2	Release of bearer towards MGW-A .....	91
8.2.3.2.3	Handling of multiple bearers (multicall).....	92
8.2.3.2.4	Example .....	92
8.2.3.3	Subsequent Inter-MSC UMTS to GSM Handover back to the anchor MSC for A Interface over IP .....	94
8.2.4	Subsequent Inter-MSC UMTS to GSM Handover to a third MSC .....	95
8.3	GSM to UMTS.....	95
8.3.1	Intra-MSC GSM to UMTS Handover .....	96
8.3.1.1	Handover Required .....	96
8.3.1.2	Handover Command/Relocation Detect .....	96
8.3.1.3	Relocation Complete .....	96
8.3.1.4	Interworking function.....	96
8.3.1.5	Codec handling.....	96
8.3.1.6	Voice Processing function.....	96
8.3.1.7	Failure Handling in MSC server .....	96
8.3.1.8	Example .....	96
8.3.2	Basic Inter-MSC GSM to UMTS Handover .....	98
8.3.2.1	MSC-A.....	99
8.3.2.1.1	Handover Required .....	99
8.3.2.1.2	Bearer establishment between MGW-A and MGW-B.....	99
8.3.2.1.3	Handover Command/Handover Detect .....	99
8.3.2.1.4	Handover Complete .....	99
8.3.2.1.5	Interworking function.....	99
8.3.2.1.6	Codec handling.....	99
8.3.2.1.7	Voice Processing function.....	99
8.3.2.1.8	Failure Handling in MSC server .....	100
8.3.2.2	MSC-B.....	100
8.3.2.2.1	MGW selection .....	100
8.3.2.2.2	Bearer establishment towards RNC-B .....	100
8.3.2.2.3	Bearer establishment between MGW-A and MGW-B.....	100
8.3.2.2.4	Codec handling.....	100
8.3.2.2.5	Voice Processing function.....	100
8.3.2.2.6	Failure Handling in MSC server .....	100
8.3.2.2.7	Example .....	101
8.3.3	Subsequent Inter-MSC GSM to UMTS Handover back to the Anchor MSC .....	103
8.3.3.1	MSC-A.....	103
8.3.3.1.1	Handover Request.....	103
8.3.3.1.2	Handover Command/Relocation Detect .....	104
8.3.3.1.3	Relocation Complete .....	104
8.3.3.1.4	Interworking function.....	104
8.3.3.1.5	Codec handling.....	104
8.3.3.1.6	Voice Processing function.....	104
8.3.3.1.7	Failure Handling in MSC server .....	104
8.3.3.2	MSC-B / MGW-B.....	104
8.3.3.2.1	Handover Required .....	104
8.3.3.2.2	Handover Complete .....	105
8.3.3.2.3	Release of bearer towards MGW-A .....	105
8.3.3.2.4	Example .....	105
8.3.4	Subsequent Inter-MSC GSM to UMTS Handover to a third MSC .....	107
8.3.5	GSM to UMTS Handover with Iu on IP .....	108
8.4	GSM to GSM .....	109
8.4.1	Intra-MSC Inter-BSS GSM to GSM Handover.....	109
8.4.1.1	Handover Required .....	109

8.4.1.2	Handover Request Acknowledge.....	110
8.4.1.3	Handover Command/Handover Detect .....	110
8.4.1.4	Handover Complete .....	110
8.4.1.5	Interworking function.....	110
8.4.1.6	Voice Processing function.....	110
8.4.1.7	Failure Handling in MSC server .....	110
8.4.1.8	Example .....	111
8.4.1.9	Intra-MSC GSM to GSM Handover for A interface over IP .....	113
8.4.2	Basic Inter-MSC GSM to GSM Handover.....	114
8.4.2.1	MSC-A / MGW-A .....	114
8.4.2.1.1	Bearer establishment between MGW-A and MGW-B.....	114
8.4.2.1.2	Handover Command/Handover Detect .....	114
8.4.2.1.3	Handover Complete .....	115
8.4.2.1.4	Interworking function.....	115
8.4.2.1.5	Voice Processing function.....	115
8.4.2.1.6	Failure Handling in MSC server .....	115
8.4.2.2	MSC-B / MGW-B.....	115
8.4.2.2.1	MGW selection .....	115
8.4.2.2.2	Bearer establishment towards BSC-B .....	115
8.4.2.2.3	Bearer establishment between MGW-A and MGW-B.....	115
8.4.2.2.4	Voice Processing function.....	115
8.4.2.2.5	Failure Handling in MSC server .....	115
8.4.2.2.6	Example .....	115
8.4.2.3	Basic Inter-MSC GSM to GSM Handover for A Interface over IP .....	118
8.4.3	Subsequent Inter-MSC GSM to GSM Handover back to the Anchor MSC.....	119
8.4.3.1	MSC-A / MGW-A .....	119
8.4.3.1.1	Handover Request Acknowledge.....	119
8.4.3.1.2	Handover Command/Handover Detect .....	120
8.4.3.1.3	Handover Complete .....	120
8.4.3.1.4	Interworking function.....	120
8.4.3.1.5	Voice Processing function.....	120
8.4.3.1.6	Failure Handling in MSC server .....	120
8.4.3.2	MSC-B/MGW-B.....	120
8.4.3.2.1	Handover Complete .....	120
8.4.3.2.2	Release of bearer towards MGW-A .....	120
8.4.3.2.3	Example .....	120
8.4.3.3	Subsequent Inter-MSC GSM to GSM Handover back to the anchor MSC for A Interface over IP ...	124
8.4.4	Subsequent GSM to GSM Handover to a third MSC .....	124
8.4.5	BSS Internal Handover.....	125
8.4.5.1	Introduction.....	125
8.4.5.2	Internal Handover Required .....	125
8.4.5.3	Internal Handover Command/Handover Detect .....	125
8.4.5.4	Handover Complete .....	125
8.4.5.5	Interworking function.....	125
8.4.5.6	Voice Processing function.....	125
8.4.5.7	Failure Handling in MSC server .....	125
8.4.5.8	Example for a successful BSS Internal Handover .....	126
8.5	Handling of GSM Services after UMTS to GSM Handover .....	128
9	Compatibility Issues.....	128
9.1	Interworking with GERAN (A i/f) .....	128
9.1.1	Introduction.....	128
9.1.2	A interface over TDM .....	129
10	General (G)MSC server-MGW Procedures.....	129
10.1	MGW Unavailable .....	129
10.2	MGW Available .....	130
10.3	MGW Recovery .....	132
10.4	(G)MSC server Recovery .....	133
10.4.1	General .....	133
10.4.2	(G)MSC Server Restoration .....	133
10.5	MGW Re-register .....	133



10.6	MGW Re-registration Ordered by (G)MSC server .....	134
10.7	Removal from Service of a Physical Termination .....	134
10.8	Restoration to Service of a Physical Termination .....	135
10.9	Audit of MGW .....	135
10.9.1	Audit of Value .....	135
10.9.2	Audit of Capability .....	136
10.10	MGW Capability Change .....	136
10.11	Void .....	137
10.12	(G)MSC Server Out of service .....	137
10.13	MGW Resource Congestion Handling - Activate .....	137
10.14	MGW Resource Congestion Handling -Indication .....	137
10.15	Control association monitoring .....	138
10.16	Hanging termination detection .....	138
11	Identities .....	139
11.1	Bearer Address and Binding Reference .....	139
11.2	MGW -Id .....	139
11.3	(G)MSC server Address .....	139
12	Operational Aspects .....	139
12.1	Charging .....	139
13	Interactions with Other Services .....	139
13.1	Enhanced Multi-Level Precedence and Pre-emption service (eMLPP) .....	140
13.2	Call Deflection Service .....	140
13.2.1	MGW selection and incoming side bearer establishment .....	140
13.2.2	IU/A-interface release .....	140
13.2.3	Notification to the Calling Subscriber .....	140
13.2.4	Initial addressing .....	140
13.2.5	Establishment of bearer towards the forwarded-to subscriber .....	140
13.2.6	Failure handling in MSC server .....	140
13.2.7	Example .....	140
13.3	Line identification Services .....	142
13.3.1	Calling Line Identification Presentation (CLIP) .....	142
13.3.2	Calling Line Identification Restriction (CLIR) .....	142
13.3.3	Connected Line Identification Presentation (COLP) .....	142
13.3.4	Connected Line Identification Restriction (COLR) .....	142
13.4	Call Forwarding Services .....	142
13.4.1	Call Forwarding Unconditional (CFU) .....	142
13.4.1.1	MGW selection .....	142
13.4.1.2	Incoming side bearer establishment .....	142
13.4.1.3	Notification to the Calling Subscriber .....	142
13.4.1.4	Initial addressing .....	142
13.4.1.5	Establishment of bearer towards the forwarded-to subscriber .....	143
13.4.1.6	Confirmation of bearer establishment .....	143
13.4.1.7	Failure handling in GMSC server .....	143
13.4.1.8	Example .....	143
13.4.2	Call Forwarding on mobile subscriber Busy (CFB) .....	144
13.4.2.1	Network Determined User Busy (NDUB) .....	144
13.4.2.1.1	MGW selection .....	144
13.4.2.1.2	Incoming side bearer establishment .....	144
13.4.2.1.3	Notification to the calling subscriber .....	144
13.4.2.1.4	Initial addressing .....	145
13.4.2.1.5	Establishment of bearer towards the forwarded-to subscriber .....	145
13.4.2.1.5	Confirmation of bearer establishment .....	145
13.4.2.1.6	Failure handling in MSC server .....	145
13.4.2.1.7	Example .....	145
13.4.2.2	User Determined User Busy (UDUB) .....	146
13.4.2.2.1	MGW selection .....	146
13.4.2.2.2	Incoming side bearer establishment .....	147
13.4.2.2.3	IU/A-interface release .....	147
13.4.2.2.4	Notification to the Calling Subscriber .....	147
13.4.2.2.5	Initial addressing .....	147

13.4.2.2.6	Establishment of bearer towards the forwarded-to subscriber .....	147
13.4.2.2.7	Confirmation of bearer establishment .....	147
13.4.2.2.8	Failure handling in MSC server .....	148
13.4.2.2.9	Example .....	148
13.4.3	Call Forwarding on No Reply (CFNRy) .....	149
13.4.3.1	MGW selection and incoming side bearer establishment .....	149
13.4.3.2	IU/A-interface release .....	149
13.4.3.3	Notification to the Calling Subscriber .....	149
13.4.3.4	Initial addressing .....	150
13.4.3.5	Establishment of bearer towards the forwarded-to subscriber .....	150
13.4.3.6	Failure handling in MSC server .....	150
13.4.3.7	Example .....	150
13.4.4	Call Forwarding on mobile subscriber Not Reachable (CFNRc) .....	151
13.4.4.1	Rerouting by HLR .....	151
13.4.4.2	Rerouting by VLR .....	151
13.4.4.2.1	MGW selection .....	152
13.4.4.2.2	Incoming side bearer establishment .....	152
13.4.4.2.3	Notification to the calling subscriber .....	152
13.4.4.2.4	Initial addressing .....	152
13.4.4.2.5	Establishment of bearer towards the forwarded-to subscriber .....	152
13.4.4.2.6	Confirmation of bearer establishment .....	153
13.4.4.2.7	Failure handling in MSC server .....	153
13.4.4.2.8	Example .....	153
13.5	Call Waiting (CW) .....	154
13.5.1	Call Confirmation of the waiting call .....	156
13.5.2	Acceptance of the Waiting Call .....	157
13.6	Call Hold (CH) .....	157
13.6.1	Hold request .....	157
13.6.2	Retrieval request .....	158
13.6.3	Setting up another call .....	158
13.6.4	Alternate from one call to the other .....	158
13.6.5	Disconnect .....	158
13.6.6	Failure handling in MSC server .....	158
13.6.7	Example 1 .....	158
13.6.8	Example 2 .....	161
13.7	Multiparty (MPTY) .....	164
13.7.1	Beginning the Multi Party call .....	164
13.7.2	Managing an active Multi Party call .....	164
13.7.3	Disconnect .....	165
13.7.4	Failure handling in MSC server .....	165
13.7.5	Example 1 – Multiparty call establishment .....	165
13.7.6	Example 2 – Private call establishment during multiparty call .....	168
13.8	Closed User Group (CUG) .....	169
13.9	Advice of Charge (AoC) .....	169
13.10	User-to-User Signalling (UUS) .....	169
13.11	Call Barring Services .....	169
13.11.1	Barring of outgoing calls .....	169
13.11.2	Barring of incoming calls other than Anonymous Call Rejection .....	169
13.11.3	Anonymous Call Rejection (ACR) .....	169
13.11.3.1	General .....	169
13.11.3.2	Anonymous Call Rejection by the GMSC .....	169
13.12	Explicit Call Transfer (ECT) .....	170
13.12.1	Connection of remote parties .....	170
13.12.2	IU/A-interface release .....	170
13.12.3	Failure handling in MSC server .....	170
13.12.4	Example .....	170
13.13	Completion of Calls to Busy Subscriber (CCBS) .....	172
13.13.1	Clearing when tones/announcements are provided to the calling subscriber .....	172
13.13.2	Network initiated mobile originated call .....	172
13.13.2.1	Early Traffic Channel Assignment .....	173
13.13.2.1.1	Example .....	173
13.13.3	CCBS Information conveyed by Call Signalling .....	174

13.14	Multiple Subscriber Profile (MSP).....	174
13.15	Multicall.....	174
13.15.1	Mobile Originating.....	174
13.15.2	Mobile Terminating.....	174
13.16	Calling Name Presentation (CNAP).....	174
13.17	Alternate Speech/Fax.....	174
13.18	Modification of the Access Bearer.....	175
13.18.1	Modification of Bearer Characteristics.....	175
13.18.1.1	Iu mode.....	175
13.18.1.2	A/Gb mode.....	175
13.18.2	IWF Protocol Change.....	175
13.19	GSM Fax.....	175
13.20	Voice group call service (VGCS), Voice broadcast service (VBS).....	176
13.20.1	Beginning the Voice group call.....	176
13.20.2	Talker change in Voice group call (1 channel model).....	176
13.20.3	Disconnect.....	177
13.20.4	Failure handling in MSC server.....	177
13.20.5	Example.....	177
14	Interactions with Other Network Features and Services.....	181
14.1	Customised Applications for Mobile network Enhanced Logic (CAMEL).....	181
14.1.1	Play Announcement/Send Tone.....	182
14.1.1.1	Example of playing announcement by the gsmSRF.....	182
14.1.2	User Interaction.....	182
14.1.2.1	Play announcement.....	182
14.1.2.2	Detect DTMF tones.....	183
14.1.2.3	Report DTMF tones.....	183
14.1.2.4	Cancel prompt and collect user information.....	183
14.1.3	Call Party Handling (CPH).....	183
14.1.3.1	Call Party Handling concepts.....	184
14.1.3.2	Initiate Call Attempt procedure.....	184
14.1.3.2.1	Example.....	184
14.1.3.3	Move Leg procedure.....	185
14.1.3.4	Split Leg procedure.....	186
14.1.3.5	CAMEL User interaction procedure.....	187
14.1.3.6	Failure handling in the MSC-S.....	188
14.2	IST.....	188
14.3	Operator Determined Barring (ODB).....	188
14.3.1	Barring of Outgoing Calls.....	188
14.3.2	Barring of Incoming Calls.....	188
14.4	DTMF.....	189
14.4.1	DTMF Tone Generation.....	189
14.4.1.1	Inband DTMF Tone Generation.....	189
14.4.1.1.1	Start DTMF.....	189
14.4.1.1.2	Stop DTMF.....	189
14.4.1.1.3	Example.....	189
14.4.1.2	Out-of-Band DTMF Tone Generation.....	190
14.4.1.2.1	Start DTMF.....	190
14.4.1.2.2	Stop DTMF.....	190
14.4.1.2.3	Example.....	190
14.4.2	DTMF Detection.....	191
14.4.2.1	Inband DTMF Detection.....	191
14.4.2.2	Out-of-Band DTMF Detection.....	192
14.5	OR.....	192
14.5.1	Optimal routing for basic mobile-to-mobile calls.....	192
14.5.2	Optimal routing for conditional call forwarding; Early call forwarding.....	192
14.5.3	Optimal routing for conditional call forwarding; Late call forwarding.....	192
14.5.3.1	MSC server.....	192
14.5.3.1.1	Resume Call Handling and clearing of connection to GMSC server.....	192
14.5.3.1.2	IU release.....	192
14.5.3.2	GMSC server.....	193
14.5.3.2.1	Resume Call Handling and Clearing of Connection to visited MSC server.....	193

14.5.3.2.2	MGW selection .....	193
14.5.3.2.3	Incoming side bearer establishment.....	193
14.5.3.2.4	Notification to the Calling Subscriber .....	193
14.5.3.2.5	Establishment of call and bearer towards the forwarded-to subscriber.....	193
14.5.3.2.6	Example .....	193
14.6	Providing tones or announcements.....	197
14.6.1	Preconditions when providing in-band information to the calling subscriber.....	197
14.6.2	Preconditions when providing in-band information to the called subscriber .....	197
14.6.3	Preconditions when providing in-band information to multiple subscribers .....	197
14.6.4	Request to play an announcement/tone.....	197
14.6.5	Stopping an announcement/tone.....	197
14.6.6	Announcement/tone completed .....	198
14.6.7	Example 1 .....	198
14.6.8	Example 2 .....	199
14.7	Global Text Telephony.....	200
14.8	Emergency Calls .....	201
14.9	Subscriber and equipment trace .....	201
14.10	Customized Alerting Tone .....	201
14.10.1	General .....	201
14.10.2	Audio CAT.....	201
14.10.2.1	Audio CAT Activated by the Calling Party .....	201
14.10.2.2	Audio CAT Activated by the Called Party .....	202
14.10.3	Multimedia CAT .....	202
14.10.3.1	Introduction.....	202
14.10.3.2	Multimedia CAT Activated by the Calling Party .....	202
14.10.3.3	Multimedia CAT Activated by the Called Party .....	203
14.10.3.3.1	Mobile originated multimedia call.....	203
14.10.3.3.2	Mobile terminated multimedia call.....	203
14.10.3.3.3	Example .....	203
15	Tunnelling .....	205
15.1	Forward Bearer Establishment .....	205
15.1.1	Outgoing Side .....	205
15.1.1.1	Tunnel Selection .....	205
15.1.1.2	Initial addressing.....	205
15.1.1.3	Fast forward tunnelling .....	205
15.1.1.4	Delayed forward tunnelling.....	206
15.1.1.5	Bearer control signalling transfer.....	206
15.1.2	Incoming Side .....	206
15.1.2.1	Initial addressing.....	206
15.1.2.2	Tunnel Selection .....	206
15.1.2.3	Fast forward tunnelling .....	206
15.1.2.4	Delayed forward tunnelling.....	207
15.1.2.5	Bearer control signalling transfer.....	207
15.1.2.6	Example .....	207
15.2	Backward Bearer Establishment.....	208
15.2.1	Outgoing Side .....	208
15.2.1.1	Tunnel Selection .....	208
15.2.1.2	Initial addressing.....	209
15.2.1.3	Fast forward tunnelling .....	209
15.2.1.4	Delayed backward tunnelling .....	209
15.2.1.5	Bearer control signalling transfer.....	209
15.2.2	Incoming Side .....	209
15.2.2.1	Initial addressing.....	209
15.2.2.2	Tunnel Selection .....	209
15.2.2.3	Fast forward tunnelling .....	209
15.2.2.4	Delayed backward tunnelling .....	210
15.2.2.5	Bearer control signalling transfer.....	210
15.2.2.6	Example .....	210
16	Messages/Procedures and their contents.....	212
16.1	Messages between (G)MSC servers .....	213

16.2	Procedures between (G)MSC server and MGW .....	215
16.2.1	Change Flow Direction .....	215
16.2.2	Join Bearer Termination.....	216
16.2.3	Isolate Bearer Termination .....	216
16.2.4	Establish Bearer.....	217
16.2.5	Prepare Bearer .....	219
16.2.6	Reserve Circuit .....	221
16.2.7	Change Through-Connection.....	222
16.2.8	Activate Interworking Function.....	222
16.2.9	Release Bearer .....	223
16.2.10	Bearer Established.....	223
16.2.11	Bearer Released .....	224
16.2.12	Release Termination .....	224
16.2.13	Tunnel Information Up.....	225
16.2.14	Tunnel Information Down .....	225
16.2.15	Send Tone.....	226
16.2.16	Stop Tone.....	226
16.2.17	Play Announcement.....	227
16.2.18	Stop Announcement.....	227
16.2.19	Announcement Completed .....	228
16.2.20	Tone Completed .....	228
16.2.21	Detect DTMF .....	229
16.2.22	Stop DTMF Detection .....	229
16.2.23	Report DTMF .....	230
16.2.24	Send DTMF.....	230
16.2.25	Stop DTMF .....	231
16.2.26	MGW Out-of-Service/ Maintenance locking .....	231
16.2.27	MGW Communication Up .....	232
16.2.28	MGW Restoration .....	232
16.2.29	MGW Register.....	233
16.2.30	MGW Re-register.....	234
16.2.31	(G)MSC Server Ordered Re-register .....	234
16.2.32	(G)MSC Server Restoration .....	235
16.2.33	(G)MSC Server Out of Service.....	235
16.2.34	Termination Out-of-Service .....	236
16.2.35	Termination Restoration .....	236
16.2.36	Audit Value .....	237
16.2.37	Audit Capability .....	237
16.2.38	Capability Update.....	238
16.2.39	Command Reject .....	238
16.2.40	Activate Voice Processing Function.....	239
16.2.41	Modify Bearer Characteristics .....	240
16.2.42	Protocol Negotiation Result .....	241
16.2.43	MGW Resource Congestion Handling - Activate .....	241
16.2.44	MGW Resource Congestion Handling - Indication .....	242
16.2.45	Bearer Modification Support.....	242
16.2.46	CTM report.....	243
16.2.47	Prepare_IP_Transport.....	244
16.2.48	Modify IP Transport Address.....	245
16.2.49	Emergency Call Indication .....	245
16.2.50	Trace Activation.....	246
16.2.51	Trace Deactivation .....	246
16.2.52	Trace Activation result notification .....	247
16.2.53	Continuity Check Tone .....	247
16.2.54	Continuity Check Verify .....	247
16.2.55	Continuity Check Response .....	248
16.2.56	Rate Change.....	248
16.2.57	Bearer Modified.....	249
16.2.58	Bearer Modification Failed.....	249
16.2.59	Termination heartbeat indication.....	250
16.2.60	Inactivity timeout activation.....	250
16.2.61	Inactivity timeout indication .....	251

16.2.62	Reserve RTP Connection Point .....	251
16.2.63	Configure RTP Connection Point.....	254
16.2.64	Reserve and Configure RTP Connection Point.....	257
16.2.65	Realm Availability Change - Activation.....	259
16.2.66	Realm Availability Change - Indication.....	260
16.2.67	Media Inactivity Notification .....	260
17	Bearer Redirect.....	261
17.1	Example of use of Bearer Redirect with Call Forwarding on No Reply (CFNRy).....	261
18	(G)MSC MGW Tandeming .....	263
18.1	Example of use of MSC MGW Tandeming during call setup to provide bearer access to specialised MGW resources.....	263
19	Timers for bearer independent CS core network.....	264
20	Multiple IP Realms .....	264
<b>Annex A (informative):</b>	<b>Change History.....</b>	<b>266</b>

---

# Foreword

This Technical Specification has been produced by the 3<sup>rd</sup> Generation Partnership Project (3GPP).

The contents of the present document are subject to continuing work within the TSG and may change following formal TSG approval. Should the TSG modify the contents of the present document, it will be re-released by the TSG with an identifying change of release date and an increase in version number as follows:

Version x.y.z

where:

- x the first digit:
  - 1 presented to TSG for information;
  - 2 presented to TSG for approval;
  - 3 or greater indicates TSG approved document under change control.
- y the second digit is incremented for all changes of substance, i.e. technical enhancements, corrections, updates, etc.
- z the third digit is incremented when editorial only changes have been incorporated in the document.

# 1 Scope

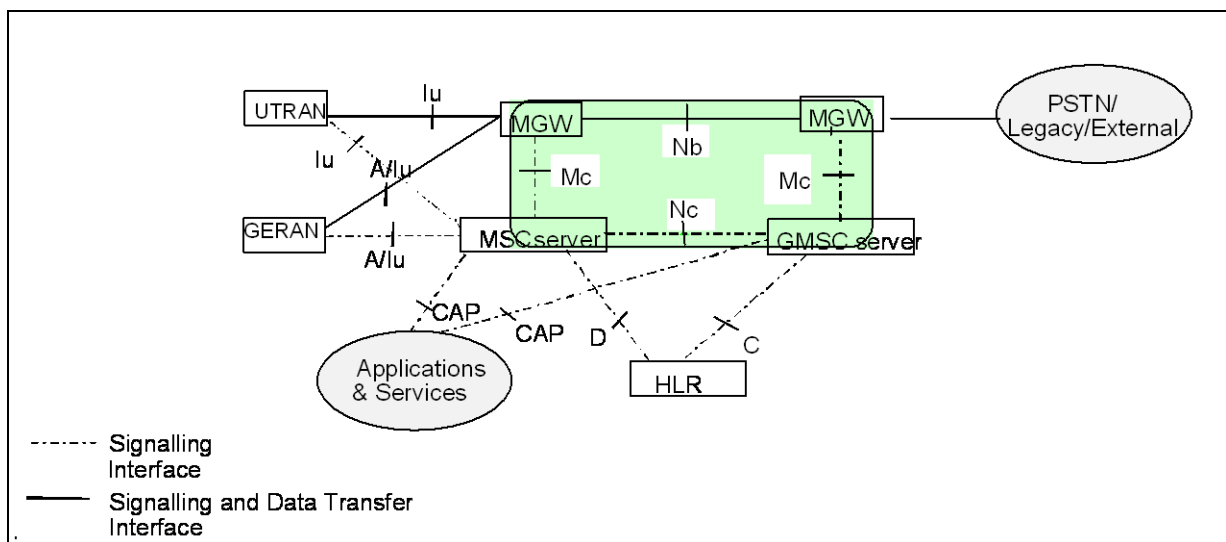
The present document defines the stage 2 description for the bearer independent CS core network. The stage 2 shall cover the information flow between the GMSC server, MSC server and media gateways. Note that nothing in the present document shall preclude an implementation of a combined MSC Server and MGW. The present document shall show the CS core network termination of the Iu interface in order to cover the information flow stimulus to the core network and describe the interaction with the supplementary and value added services and capabilities.

For the purposes of the present document, the protocol used over the Nc interface is an enhanced call control protocol supporting call bearer separation such as BICC (which is specified in [22]). The protocol used over the Mc interface is H.248 (which is specified in 3GPP TS 29.232 [6]). Existing specifications and recommendations shall not be repeated, as such the relevant specification shall be referred to.

SIP-I based CS core network is further specified in 3GPP TS 23.231 [42].

Local Call Local Switch (LCLS) functionality is further specified in 3GPP TS 23.284 [45].

The present document is applicable only for ATM or IP transport in the CS core network.



**Figure 1: CS core network logical architecture**

The CAP interfaces and the interfaces towards the HLR are outside the scope of the present document.

Details of Transcoder-Free Operation are outside the scope of the present document. Please see 3GPPTS 23.153 [3] for more information.

# 2 References

The following documents contain provisions which, through reference in this text, constitute provisions of the present document.

- References are either specific (identified by date of publication, edition number, version number, etc.) or non-specific.
- For a specific reference, subsequent revisions do not apply.
- For a non-specific reference, the latest version applies. In the case of a reference to a 3GPP document (including a GSM document), a non-specific reference implicitly refers to the latest version of that document *in the same Release as the present document*.

[1] 3GPP TR 21.905: "Vocabulary for 3GPP Specifications".



- [2] 3GPP TS 23.002: "Network architecture".
- [3] 3GPP TS 23.153: "Out of Band Transcoder Control; Stage 2".
- [4] 3GPP TS 24.008: "Mobile radio interface Layer 3 specification; Core network protocols; Stage 3".
- [5] ITU-T Recommendation H.248: "Gateway control protocol".
- [6] 3GPP TS 29.232: "Media Gateway Controller (MGC) - Media Gateway (MGW) interface; Stage 3".
- [7] 3GPP TS 29.415: " Core Network Nb Interface User Plane Protocols ".
- [8] 3GPP TS 23.009: "Handover procedures".
- [9] 3GPP TS 23.072: "Call Deflection Supplementary Service; Stage2".
- [10] 3GPP TS 23.078: "Customized Applications for Mobile network Enhanced Logic (CAMEL); Stage 2".
- [11] 3GPP TS 23.079: "Support of Optimal Routing (SOR); Technical Realization; Stage2".
- [12] 3GPP TS 23.082: "Call Forwarding (CF) Supplementary Services; Stage 2".
- [13] 3GPP TS 23.083: "Call Waiting (CW) and Call Hold (HOLD) Supplementary Services; Stage 2".
- [14] 3GPP TS 23.084: "MultiParty (MPTY) Supplementary Service; Stage 2".
- [15] 3GPP TS 23.091: "Explicit Call Transfer (ECT) Supplementary Service; Stage 2".
- [16] 3GPP TS 23.093: "Technical realization of Completion of Calls to Busy Subscriber (CCBS); Stage 2".
- [17] 3GPP TS 23.135: "Multicall supplementary service; Stage 2".
- [18] 3GPP TS 23.108: "Mobile radio interface layer 3 specification core network protocols; Stage 2".
- [19] 3GPP TS 42.032: "Immediate Service Termination (IST); Service description; Stage 1".
- [20] 3GPP TS 25.415: "UTRAN Iu interface user plane protocols".
- [21] 3GPP TS 29.414: "Core Network Nb data transport and transport signalling".
- [22] 3GPP TS 29.205: "Application of Q.1900 series to bearer independent circuit-switched core network architecture; Stage 3".
- [23] 3GPP TS 29.010: "Information Element Mapping between Mobile Station - Base Station System (MS - BSS) and Base Station System - Mobile-services Switching Centre (BSS - MSC); Signalling Procedures and the Mobile Application Part (MAP)".
- [24] 3GPP TS 43.045: "Technical Realization Of Facsimile Group 3 service - Transparent".
- [25] 3GPP TS 23.146: "Technical realization of facsimile group 3 non-transparent".
- [26] 3GPP TS 25.413: "UTRAN Iu Interface RANAP signalling"
- [27] 3GPP TS 48.008: "Mobile Switching Centre – Base Station system (MSC – BSS) interface layer 3 Specification"
- [28] 3GPP TS 23.226: "Global Text Telephony (GTT); Stage 2"
- [29] 3GPP TS 43.051: "GSM/EDGE Radio Access Network (GERAN) overall description; Stage 2;"
- [30] 3GPP TS 25.412: "UTRAN Iu interface signalling transport".
- [31] 3GPP TS 25.410: "UTRAN Iu Interface: General Aspects and Principles".
- [32] 3GPP TS 25.414: "UTRAN Iu interface data transport and transport signalling".

- [33] 3GPP TS 23.014: "Technical Specification Group Core Network; Support of Dual Tone Multi-Frequency (DTMF) signalling".
- [34] 3GPP TS 32.421: "Subscriber and equipment trace: Trace concepts and requirements".
- [35] 3GPP TS 32.422: "Subscriber and equipment trace: Trace control and configuration management".
- [36] 3GPP TS 32.423: "Subscriber and equipment trace: Trace data definition and management".
- [37] 3GPP TS 29.007: "General requirements on interworking between the Public Land Mobile Network (PLMN) and the Integrated Services Digital Network (ISDN) or Public Switched Telephone Network (PSTN)".
- [38] 3GPP TS 23.172: "Technical Specification Group Core Network and Terminals; Technical realization of Circuit Switched (CS); multimedia service UDI/RDI fallback and service modification; Stage 2".
- [39] 3GPP TS 43.068: "Voice Group Call Service (VGCS)".
- [40] 3GPP TS 43.069: "Voice Broadcast Service (VBS)".
- [41] IETF RFC 2663: "IP Network Address Translator (NAT) Terminology and Considerations".
- [42] 3GPP TS 23.231: "SIP-I based Circuit Switched Core Network ; Stage 2".
- [43] 3GPP TS 29.002: "Mobile Application Part (MAP) specification".
- [44] 3GPP TS 29.235: "Interworking between SIP-I based circuit-switched core network and other networks".
- [45] 3GPP TS 23.284: "Local Call Local Switch; Stage 2".
- [46] 3GPP TS 23.088: "Call Barring (CB) Supplementary Services; Stage 2".

---

## 3 Symbols and abbreviations

### 3.1 Symbols

For the purposes of the present document, the following symbols apply:

Iu	Interface between the RNS and the core network. It is also considered as a reference point.
Mc	Interface between the server and the media gateway.
Nb	Interface between media gateways.
Nc	The NNI call control interface between (G)MSC servers.

### 3.2 Abbreviations

For the purposes of the present document, the following abbreviations apply:

BCF	Bearer Control Function
BICC	Bearer Independent Call Control
CIC	Call Instance Code
CCF	Call Control Function
CS	Circuit Switched
GERAN	GSM/EDGE Radio Access Network
IAM	Initial Address Message
IETF	Internet Engineering Task Force
IP	Internet Protocol
IPv4	Internet Protocol version 4
IPv6	Internet Protocol version 6
LCLS	Local Call Local Switch

MGW	Media GateWay
MGC	Media Gateway Controller
MSC-S	MSC Server
MTP2	Message Transfer Part layer 2
MTP3	Message Transfer Part layer 3
NNI	Network-Network interface
RAB	Radio Access Bearer
RANAP	Radio Access Network Application Protocol
SBSS	Serving Base Station System
SRNS	Serving Radio Network Subsystem
TCAP	Transaction Capabilities Application Part
TFO	Tandem Free Operation
TRAU	Transcoder and Rate Adapter Unit
TrFO	Transcoder Free Operation
UDP	User Datagram Protocol
UTRAN	UMTS Terrestrial Radio Access Network

### 3.3 Definitions

**UE:** User equipment. This specification makes no distinction between MS (mobile station) and UE.

**A/Gb mode:** mode of operation of the UE when connected to the Core Network via GERAN and the A and/or Gb interfaces. Throughout this specification the term GSM refers to GERAN A/Gb mode.

**Iu mode:** mode of operation of the UE when connected to the Core Network via GERAN or UTRAN and the Iu interface. Throughout this specification the term UMTS refers to UTRAN or GERAN Iu mode.

---

## 4 Main Concepts

### 4.1 General

The circuit switched core network enables the support of different transports (e.g. ATM or IP) in a bearer-independent fashion. For the ATM and IP transport, there is a strict separation between the call control level and the bearer control level. In the case of ATM or IP transport, the passage of compressed speech at variable bit rates is possible through the CS core network.

The CS core network shall employ the MSC server, GMSC server and media gateways. The GMSC server and MSC server shall provide the call control and mobility management functions, and the media gateway shall provide the bearer control and transmission resource functions. The media gateway shall contain the stream manipulating functions.

The GMSC server and MSC servers are connected to the media gateway via the Mc reference point. The MSC servers and GMSC servers are connected with the Nc reference point. There may be a number of call control transit nodes between the MSC server and GMSC server in the Nc reference point. The MGWs are connected with the Nb reference point.

The users connected to the CS core network shall not be aware whether a MSC server – media gateway combination is used, or a monolithic MSC is used.

### 4.2 Bearer-Independent Call Control

The protocol used on the Nc interface shall be a call control protocol supporting IP and ATM transports in a bearer-independent manner for the ISDN service set, allowing the physical separation of the call control entities from the bearer control entities.

An exception to this bearer independence concept is if Iu interface is on IP and the IP addresses are to be exchanged via call control plane signalling (known by the MSC due to configuration data). In this case the specific handling is described separately.

Another exception to the bearer independence concept is the case of A interface user plane over IP (AoIP). In that case the IP addresses/UDP port numbers are to be exchanged via call control plane signalling. Specific handling is also described separately for this case.

## 4.3 H.248/MEGACO

H.248/MEGACO has been jointly developed within the ITU-T and the IETF, and supports a separation of call control entities from bearer control entities, and a separation of bearer control entities from transport entities. H.248 is used on the Mc interface between the (G)MSC servers and the media gateway.

---

# 5 General Circuit Switched Core Network Domain Architecture

## 5.1 Logical Architecture

The overall CS core network logical architecture is shown in figure 1.

### 5.1.1 CS Core Network Nodes

#### 5.1.1.1 MSC Server

The MSC server mainly comprises the call control and mobility control parts of a GSM/UMTS MSC as described in 3GPP TS 23.002 [2]. It is also integrated with a VLR to hold the mobile subscriber's service data and CAMEL related data.

The MSC server terminates the user-network signalling (see 3GPP TS 24.008 [4]) and translates it into the signalling over the Nc interface. The MSC Server terminates the Iu control plane signalling and its transport bearer (see 3GPP TS 25.413 [26] and 3GPP TS 25.412 [30]). It also terminates the signalling over the Mc interface with the Media Gateway.

The MSC server controls the parts of the call state model that pertain to connection control for media channels in an MGW. It also contains the "Call Control Function" in the BICC model.

#### 5.1.1.2 GMSC Server

The GMSC server mainly comprises the call control and mobility control parts of a GSM/UMTS GMSC as described in 3GPP TS 23.002 [2].

The GMSC server terminates the signalling over the Nc interface and the call control interfaces to the external networks. It also terminates the signalling over the Mc interface towards the Media Gateway.

The GMSC server controls the parts of the call state model that pertain to connection control for media channels in an MGW. It also contains the "Call Control Function" in the BICC model.

#### 5.1.1.3 Media Gateway

The Media Gateway terminates the signalling over the Mc interface from the (G)MSC servers. The Media Gateway terminates the Iu transport network control plane signalling with its transport bearer (see 3GPP TS 25.410 [31] and 3GPP TS 25.414 [32]). The Media Gateway also terminates the Iu user plane protocol (see 3GPP TS 25.415 [20]). It also terminates the bearer control signalling and the transport bearer over the Nb interface (see 3GPP TS 29.414 [21] and 3GPP TS 29.415 [7]).

The Media Gateway contains bearer terminations and media manipulation equipment (e.g. transcoders, echo cancellers, or tone senders). It may perform media conversion and framing protocol conversion.

## 5.1.2 CS Core Network Interfaces and Reference Points

### 5.1.2.1 Mc Interface

The Mc reference point in the present document considers the aspects of the interface between the (G)MSC server and the MGW. The H.248 protocol [5] together with 3GPP specific extensions/packages shall be used over the Mc interface.

### 5.1.2.2 Nc Interface

The Network-Network based call control is used over the Nc interface. Any suitable call control protocol may be used over the Nc interface (e.g. BICC).

### 5.1.2.3 Nb Interface

The bearer control signalling and transport are carried over the Nb interface.

## 5.2 Network Interworking

### 5.2.1 Interworking on the Nc Reference Point

Interworking between the Nc reference point, call control protocols and ISUP is defined within the 3GPP stage 3 documentation for each protocol (or by references specified in stage 3 documentation [6]).

### 5.2.2 Interworking on the Nb Reference Point

The interworking is specified in 3GPP TS 29.415 [7] and 3GPP TS 29.414 [21].

---

## 6 Call Establishment

NOTE1: All message sequence charts in this clause are examples. All valid call establishment message sequences can be derived from the example message sequences and associated message pre-conditions.

NOTE2: The continuity indication in the IAM is not used to indicate that a continuity check will be performed on the current leg of the call, but it is used to indicate that a Continuity message can be expected as a result of a continuity check on a preceding ISUP circuit, or establishment of a preceding bearer connection.

## 6.1 Basic Mobile Originating Call

### 6.1.1 Forward bearer establishment

The mobile originating call shall be established in accordance with 3GPP TS 23.108 [17]. The following clauses describe the additional requirements for the bearer independent CS core network. If out-of-band transcoder control is applied for a speech call, it shall be performed in accordance with 3GPP TS 23.153 [3].

#### 6.1.1.1 MGW selection

The MSC server shall select an MGW for the bearer connection before it performs the access bearer assignment or the network side bearer establishment. This may happen either before sending the IAM or after receiving the Bearer Information message. In the latter case, the MGW selection may be based on a possibly received MGW -id from the succeeding node (bullet 1 or bullet 2 in figure 6.2). For GSM, if performing Service based handover (see 3GPP TS 48.008 [27]) the MSC Server may omit MGW selection at this time.

### 6.1.1.2 Initial addressing

The MSC server shall indicate in the IAM that forward bearer establishment is to be used. If access bearer assignment has not been completed, the MSC server shall indicate that the Continuity message will follow. However, if late access bearer assignment (assignment after alerting or answer) is used the MSC server shall not indicate that the Continuity message will follow. The MSC server provides the bearer characteristics to the succeeding node in the IAM. If the MGW is selected at an earlier stage the MGW-id may also be provided in the IAM (bullet 1 in figure 6.2).

### 6.1.1.3 Network side bearer establishment

The MSC server shall select bearer characteristics for the network side bearer connection before sending the IAM. After the succeeding node has provided a bearer address and a binding reference in the Bearer Information message the MSC server uses the Establish Bearer procedure to request the MGW to establish a bearer towards the destination MGW. The MSC server provides the MGW with the bearer address, the binding reference and the bearer characteristics (bullet 2 in figure 6.2).

### 6.1.1.4 Access bearer assignment

The MSC server shall select bearer characteristics for the access bearer.

For UMTS, before the MSC server starts the access bearer assignment, the MSC server requests the MGW to prepare for the access bearer establishment using the Prepare Bearer procedure. The MSC server requests the MGW to provide a bearer address and a binding reference, provides the MGW with the bearer characteristics and requests notification that the bearer can be modified. For speech calls, the MSC server shall provide the MGW with the speech coding information and conditionally GTT related information in accordance with 3GPP TS 23.226 [28] for the bearer. For a non-speech call the MSC server also provides the MGW with a PLMN Bearer Capability [4]. After the MGW has replied with the bearer address and the binding reference the MSC server requests access bearer assignment using the provided bearer address and binding reference (bullet 3 in figure 6.2) in accordance with 3GPP TS 25.413 [26]. The MSC shall only be notified by the MGW using Bearer Modification Support procedure if the existing link characteristics of the access bearer can be modified at a later stage, see subclause 13.18.1.

For GERAN Iu mode the MSC Server receives the GERAN capabilities within the RANAP INITIAL UE MESSAGE, indicating the services (e.g. for CS speech services the supported codec types and, for an adaptive codec type, the supported codec modes (for definition see [27])), which will be available at the RAB establishment procedure. The MSC server shall take the indicated GERAN capabilities into account as well as the received MS capabilities when negotiating a service. Additionally, when requesting the access bearer assignment the MSC server shall indicate to the GERAN the selected service (e.g. selected codec type). The MSC server shall not set codec information in the NAS Synchronisation Indicator (see [4]). Instead it shall set codec information in the GERAN BSC container.

For GSM, before the MSC server starts the access bearer assignment, the MSC server uses the Reserve Circuit procedure to seize a TDM circuit. For a non-speech call the MSC server also provides the MGW with a PLMN Bearer Capability [4] and a GSM channel coding. After the MGW has replied to the TDM circuit seizure, the MSC server requests access bearer assignment (bullet 4 in figure 6.2) in accordance with 3GPP TS 48.008 [27]. If performing Service based handover (see 3GPP TS 48.008 [27]) the MSC Server may omit to perform Reserve Circuit procedure.

### 6.1.1.5 Framing protocol initialisation

In 3GPP CS CN speech and data shall be carried using the Iu/Nb User Plane Protocol. The specification for the Iu UP protocol is defined in [20] and the Nb UP Protocol in [7] and [21]. The Iu/Nb UP Protocol is established through the CN in a forward direction. This is established independently of the bearer establishment direction. The MGW derives the forward direction from information sent by the MSC server within the Establish Bearer and Prepare Bearer procedures [6].

### 6.1.1.6 Confirmation of bearer establishment

If the IAM which was sent to the succeeding node indicated that the Continuity message will follow, the MSC server sends the Continuity message when the access bearer assignment has been completed (bullet 5 in figure 6.2).

### 6.1.1.7 Through-Connection

During any one of the Prepare Bearer, Reserve Circuit and Establish Bearer procedures, the MSC server will use the Change Through-Connection procedure to request the MGW to through-connect the bearer terminations so that the bearer will be backward through-connected (bullet 2, and bullet 3 or 4 in figure 6.2).

For a multimedia call, the MSC may request the MGW to both-way through-connect the bearer using the Change Through-Connection procedure to generate a multimedia CAT (see subclause 14.10.3.1).

Otherwise when MSC server receives the answer indication, it requests the MGW to both-way through-connect the bearer using the Change Through-Connection procedure (bullet 6 in figure 6.2).

### 6.1.1.8 Interworking function

The MGW may use an interworking function that is based on the PLMN Bearer Capability [4] of the bearer termination. The activation of the possible interworking function in both bearer terminations will be requested by the MSC server at reception of the answer indication using the Activate Interworking Function procedure (bullet 6 in figure 6.2).

### 6.1.1.9 Codec handling

The MGW may include a speech transcoder based upon the speech coding information provided to each bearer termination.

### 6.1.1.10 Voice Processing function

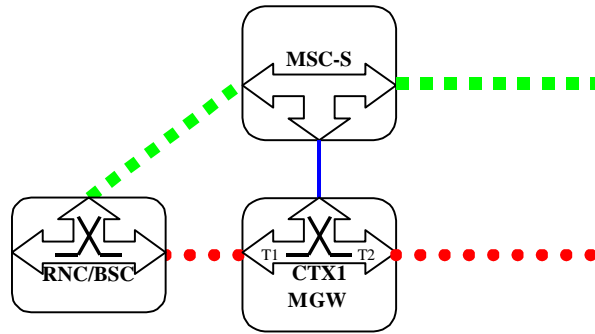
A voice processing function located on the MGW may be used to achieve desired acoustic quality on the bearer terminations. The MSC server shall request the activation of voice processing functions in the bearer terminations. For non-speech calls, the MSC server has the ability to instruct the MGW to disable the voice processing functions (bullet 6 in figure 6.2).

### 6.1.1.11 Failure handling in MSC server

If any procedure between the MSC server and the MGW has not completed successfully or the MSC server receives a Bearer Released procedure from the MGW, the call shall be cleared as described in clause 7.3, (G)MSC server initiated call clearing or in clause 7.4, MGW initiated call clearing. Alternatively, the MSC server may only release the resources in the MGW that caused the failure, possibly select a new MGW for the bearer connection and continue the call establishment using new resources in the selected MGW.

### 6.1.1.12 Example

Figure 6.1 shows the network model for the mobile originating call. The "squared" line represents the call control signalling. The "dotted" line represents the bearer control signalling (not applicable in A/Gb mode for the A-interface) and the bearer. The MSC server seizes one context with two bearer terminations in the MGW. The bearer termination T1 is used for the bearer towards the RNC/BSC and the bearer termination T2 is used for the bearer towards the succeeding MGW.



**Figure 6.1: Basic Mobile Originating Call, Forward Bearer Establishment (network model)**

Figure 6.2 shows the message sequence chart example for the mobile originating call. In the example the MSC server requests seizure of the network side bearer termination and establishment of the bearer when the Bearer Information message is received from the succeeding node. After the network side bearer termination is seized the MSC server requests seizure of the access side bearer termination. When the MSC server receives an answer indication, it shall request the MGW to both-way through-connect the bearer terminations. The MSC shall also request the possible activation of the interworking function in both terminations and the possible activation of the voice processing functions for the bearer terminations.



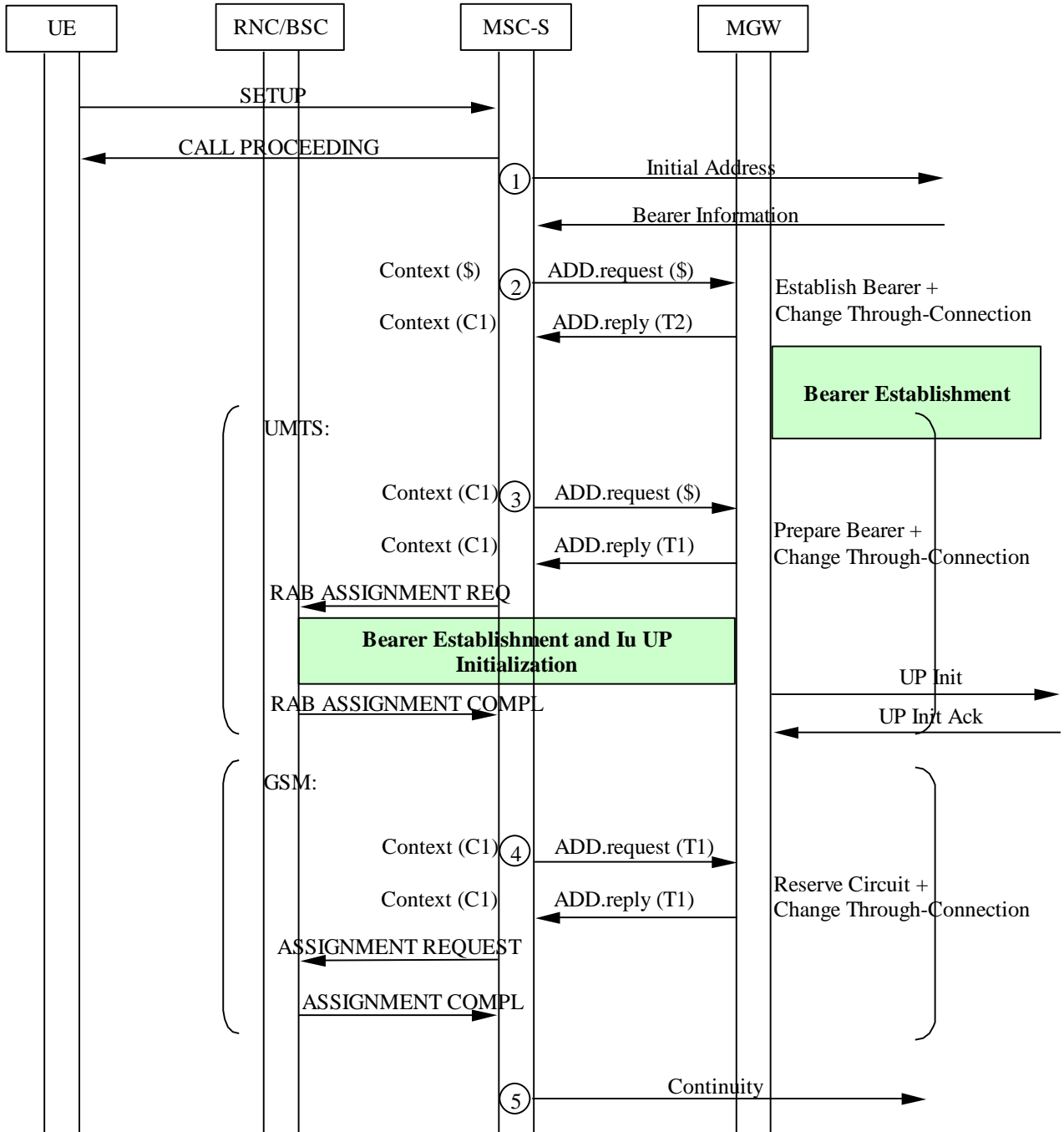
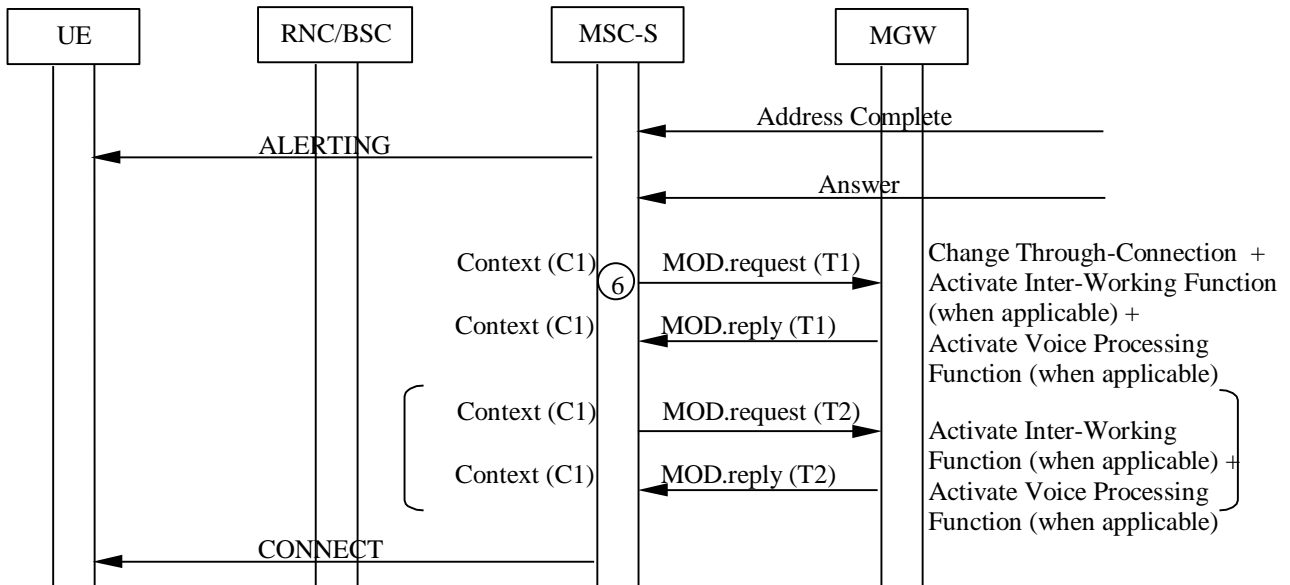


Figure 6.2/1: Basic Mobile Originating Call, Forward Bearer Establishment (message sequence chart)



**Figure 6.2/2: Basic Mobile Originating Call, Forward Bearer Establishment (message sequence chart continue)**

## 6.1.2 Backward bearer establishment

The basic mobile originating call shall be established in accordance with 3GPP TS 23.108 [17]. The following clauses describe the additional requirements for the bearer independent CS core network. If out-of-band transcoder control is applied for a speech call, it shall be performed in accordance with 3GPP TS 23.153 [3].

### 6.1.2.1 MGW selection

The MSC server shall select an MGW for the bearer connection before it performs the access bearer assignment or the network side bearer establishment. This happens before sending the IAM (bullet 1 or 2 in figure 6.4). For GSM, if performing Service based handover (see 3GPP TS 48.008 [27]) the MSC Server may omit MGW selection at this time.

### 6.1.2.2 Network side bearer establishment

The MSC server shall select bearer characteristics for the network side bearer connection before sending the IAM. The MSC server requests the MGW to prepare for the network side bearer establishment using the Prepare Bearer procedure. The MSC server requests the MGW to provide a bearer address and a binding reference, and provides the MGW with the bearer characteristics (bullet 3 in figure 6.4). After the MGW has replied with the bearer address and the binding reference, the MSC server sends the IAM to the succeeding node.

### 6.1.2.3 Initial addressing

The MSC server shall indicate in the IAM that backward bearer establishment is to be used. If access bearer assignment has not been completed, the MSC server shall indicate that the Continuity message will follow. However, if late access bearer assignment (assignment after alerting or answer) is used the MSC server shall not indicate that the Continuity message will follow. The MSC server provides the bearer characteristics, the bearer address and the binding reference to the succeeding node in the IAM. The MSC server may also provide the MGW -id in the IAM (bullet 4 in figure 6.4).

#### 6.1.2.4 Access bearer assignment

The MSC server shall select bearer characteristics for the access bearer.

For UMTS, before the MSC server starts the access bearer assignment, the MSC server requests the MGW to prepare for the access bearer establishment using the Prepare Bearer procedure. The MSC server requests the MGW to provide a bearer address and a binding reference, provides the MGW with the bearer characteristics and requests notification that the bearer can be modified. For speech calls, the MSC server shall provide the MGW with the speech coding information and conditionally GTT related information in accordance with 3GPP TS 23.226 [28] for the bearer. For a non-speech call the MSC server also provides the MGW with a PLMN Bearer Capability [4]. After the MGW has replied with the bearer address and the binding reference the MSC server requests access bearer assignment using the provided bearer address and binding reference (bullet 1 in figure 6.4) in accordance with 3GPP TS 25.413 [26]. The MSC shall only be notified by the MGW using the Bearer Modification Support procedure if the existing link characteristics of the access bearer can be modified at a later stage, see subclause 13.18.1.

For GERAN Iu mode the MSC Server receives the GERAN capabilities within the RANAP INITIAL UE MESSAGE, indicating the services (e.g. for CS speech services the supported codec types and, for an adaptive codec type, the supported codec modes (for definition see [27])), which will be available at the RAB establishment procedure. The MSC server shall take the indicated GERAN capabilities into account as well as the received MS capabilities when negotiating a service. Additionally, when requesting the access bearer assignment the MSC server shall indicate to the GERAN the selected service (e.g. selected codec type). The MSC server shall not set codec information in the NAS Synchronisation Indicator (see [4]). Instead it shall set codec information in the GERAN BSC container.

For GSM, before the MSC server starts the access bearer assignment, the MSC server uses the Reserve Circuit procedure to seize a TDM circuit. For a non-speech call the MSC server also provides the MGW with a PLMN Bearer Capability [4] and a GSM channel coding. After the MGW has replied the TDM circuit seizure the MSC server requests access bearer assignment (bullet 2 in figure 6.4) in accordance with 3GPP TS 48.008 [27]. If performing Service based handover (see 3GPP TS 48.008 [27]) the MSC Server may omit to perform Reserve Circuit procedure.

#### 6.1.2.5 Framing protocol initialisation

In 3GPP CS CN speech and data shall be carried using the Iu/Nb User Plane Protocol. The specification for the Iu UP protocol is defined in [20] and the Nb UP Protocol in [7] and [21]. The Iu/Nb UP Protocol is established through the CN in a forward direction. This is established independently of the bearer establishment direction. The MGW derives the forward direction from information sent by the MSC server within the Establish Bearer and Prepare Bearer procedures [6].

#### 6.1.2.6 Confirmation of bearer establishment

If the IAM was sent to the succeeding node indicating that the Continuity message will follow, the MSC server sends the Continuity message when the access bearer assignment has been completed.

#### 6.1.2.7 Through-Connection

During the Prepare Bearer or Reserve Circuit procedures, the MSC server will use the Change Through-Connection procedure to request the MGW to through-connect the bearer terminations so that the bearer will be backward through-connected (bullet 1 or 2, and bullet 3 in figure 6.4).

For a multimedia call, the MSC may request the MGW to both-way through-connect the bearer using the Change Through-Connection procedure to generate a multimedia CAT (see subclause 14.10.1).

Otherwise when the MSC server receives the answer indication, it requests the MGW to both-way through-connect the bearer using the Change Through-Connection procedure (bullet 5 in figure 6.4).

#### 6.1.2.8 Interworking function

The MGW may use an interworking function that is based on the PLMN Bearer Capability [4] of the bearer termination. The activation of the possible interworking function in both bearer terminations will be requested by the MSC server at reception of the answer indication using the Activate Interworking Function procedure (bullet 5 in figure 6.4).

### 6.1.2.9 Codec handling

The MGW may include a speech transcoder based upon the speech coding information provided to each bearer termination.

### 6.1.2.10 Voice Processing function

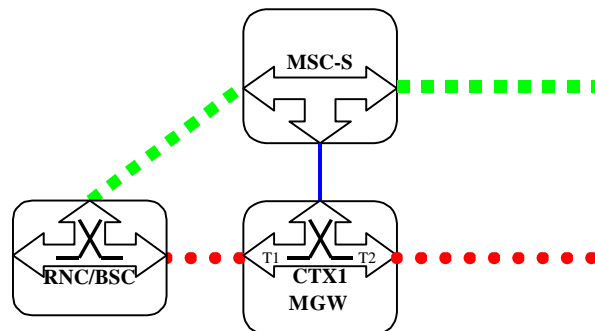
A voice processing function located on the MGW may be used to achieve desired acoustic quality on the bearer terminations. The MSC server shall request the activation of the voice processing functions in the bearer terminations. For non-speech calls, the MSC server has the ability to instruct the MGW to disable the voice processing functions (bullet 5 in figure 6.4).

### 6.1.2.11 Failure handling in MSC server

If any procedure between the MSC server and the MGW has not completed successfully or the MSC server receives a Bearer Released procedure from the MGW, the call shall be cleared as described in clause 7.3, (G)MSC server initiated call clearing or in clause 7.4, MGW initiated call clearing. Alternatively, the MSC server may only release the resources in the MGW that caused the failure, possibly select a new MGW for the bearer connection and continue the call establishment using new resources in the selected MGW.

### 6.1.2.12 Example

Figure 6.3 shows the network model for the mobile originating call. The "squared" line represents the call control signalling. The "dotted" line represents the bearer control signalling (not applicable in A/Gb mode for the A-interface) and the bearer. The MSC server seizes one context with two bearer terminations in the MGW. The bearer termination T1 is used for the bearer towards the RNC/BSC and the bearer termination T2 is used for the bearer towards the succeeding MGW.



**Figure 6.3: Basic Mobile Originating Call, Backward Bearer Establishment (network model)**

Figure 6.4 shows the message sequence chart example for the mobile originating call. In the example the MSC server requests seizure of the access side bearer termination and network side bearer termination. As the access bearer assignment has been completed before the IAM, no Continuity message will be sent. When the MSC server receives an answer indication, it requests the MGW to both-way through-connect the bearer terminations. The MSC server, shall also request the possible activation of the interworking function in both bearer terminations. The MSC server shall request the possible activation of the voice processing functions for the bearer terminations.

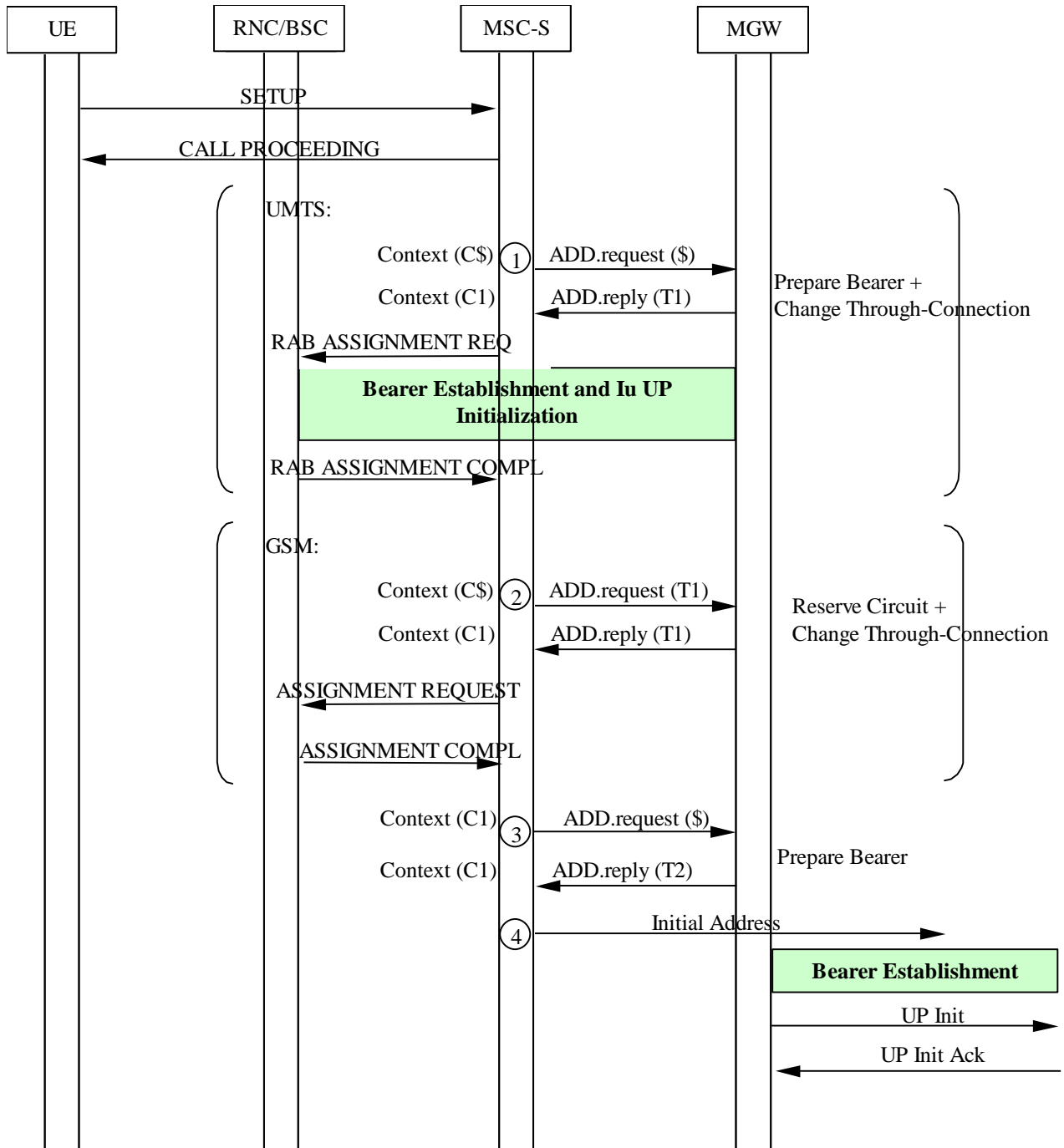
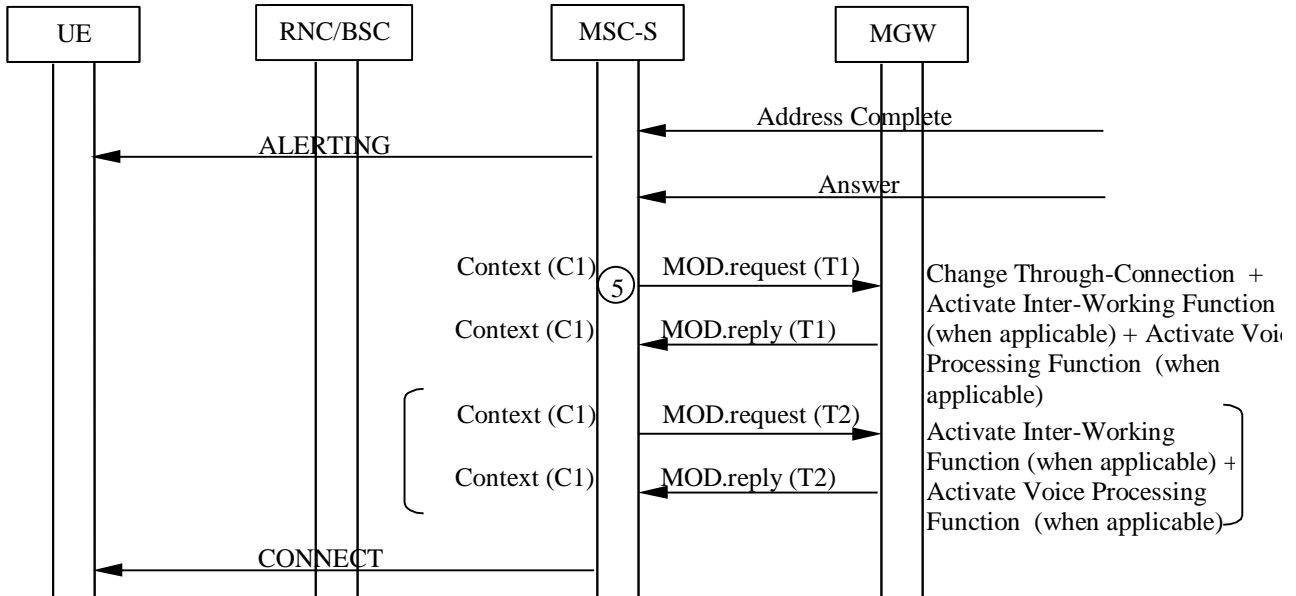


Figure 6.4/1: Basic Mobile Originating Call, Backward Bearer Establishment (message sequence chart)



**Figure 6.4/2: Basic Mobile Originating Call, Backward Bearer Establishment (message sequence chart continue)**

### 6.1.3 Originating Call Establishment For Iu Interface on IP

If IuCS on IP is supported by the MSC server, the Core Network side procedures described in 6.1.1 or 6.1.2 shall apply. For the access side termination, the exchange of IP addresses via call control procedures is described in this clause.

Before the MSC server starts the access bearer assignment, the MSC server requests the MGW to prepare for the access bearer using the Prepare\_IP\_Transport procedure. The MSC server requests the MGW to provide an IP Transport Address and a Iu UDP Port and provides the MGW with the bearer characteristics. For speech calls, the MSC server shall provide the MGW with the speech coding information and conditionally GTT related information in accordance with 3GPP TS 23.226 [28]. For a non-speech call the MSC server also provides the MGW with a PLMN Bearer Capability [4]. After the MGW has replied with the IP address and UDP Port the MSC server requests access bearer assignment using the provided IP address and UDP Port in accordance with 3GPP TS 25.413 [26]. The IP addresses and UDP Ports of the MGW and the RNC are exchanged via the RANAP procedures. If the bearer transport is IP and IuUP mode is Transparent, when the MSC receives the RANAP RAB assignment response it shall send the RNC IP address and UDP Port to the MGW Access bearer termination using the Modify\_IP\_Transport\_Address procedure.

If the bearer transport is IP and IuUP mode is Support, the MGW shall use the source IP address and UDP Port of the IuUP Init packet received from the radio access network as the destination address for subsequent downlink packets.

The sequence is shown in figure 6.1.3/1.

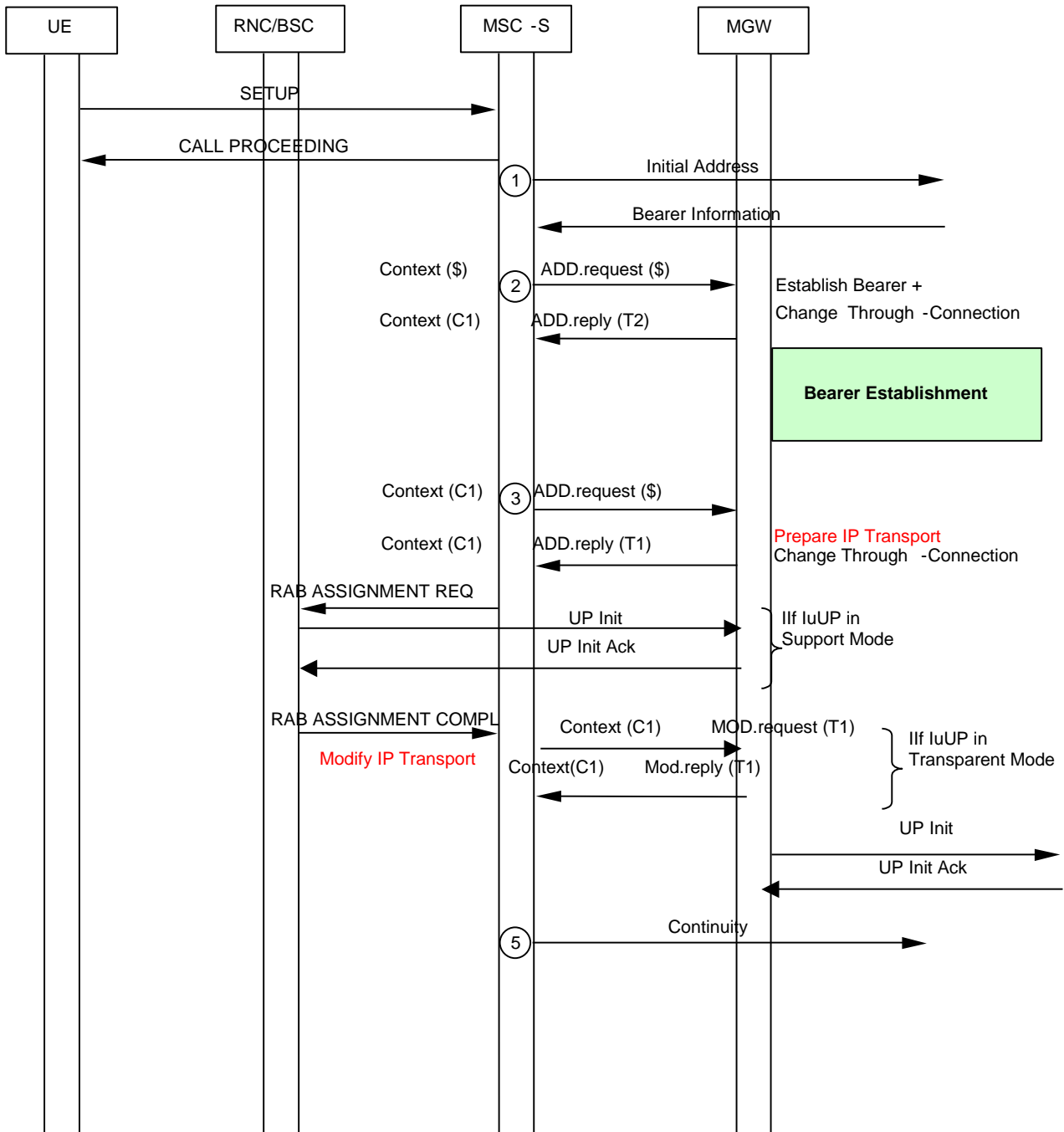


Figure 6.1.3/1: Call Establishment for lu on IP

### 6.1.4 Forward bearer establishment with Trace Session Activation

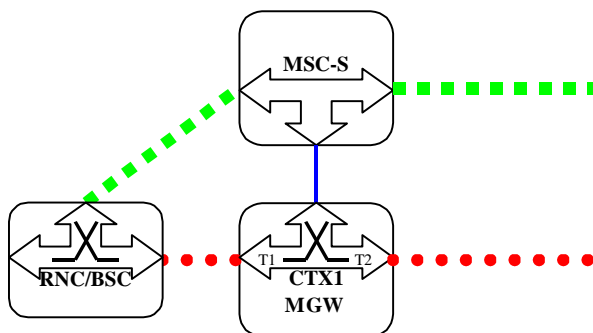
The mobile originating call shall be established in accordance with 3GPP TS 23.108 [17]. The following clause describe the additional requirement for the bearer independent CS core network if a trace session is activated from a MSC Server to a MGW.

#### 6.1.4.1 Trace activation

When a Trace Session is activated in the MSC Server and the trace control and configuration parameters requires Trace Session activation to the MGW, the MSC Server activates the Trace Session to the MGW by using the trace activation procedure.

### 6.1.4.2 Example

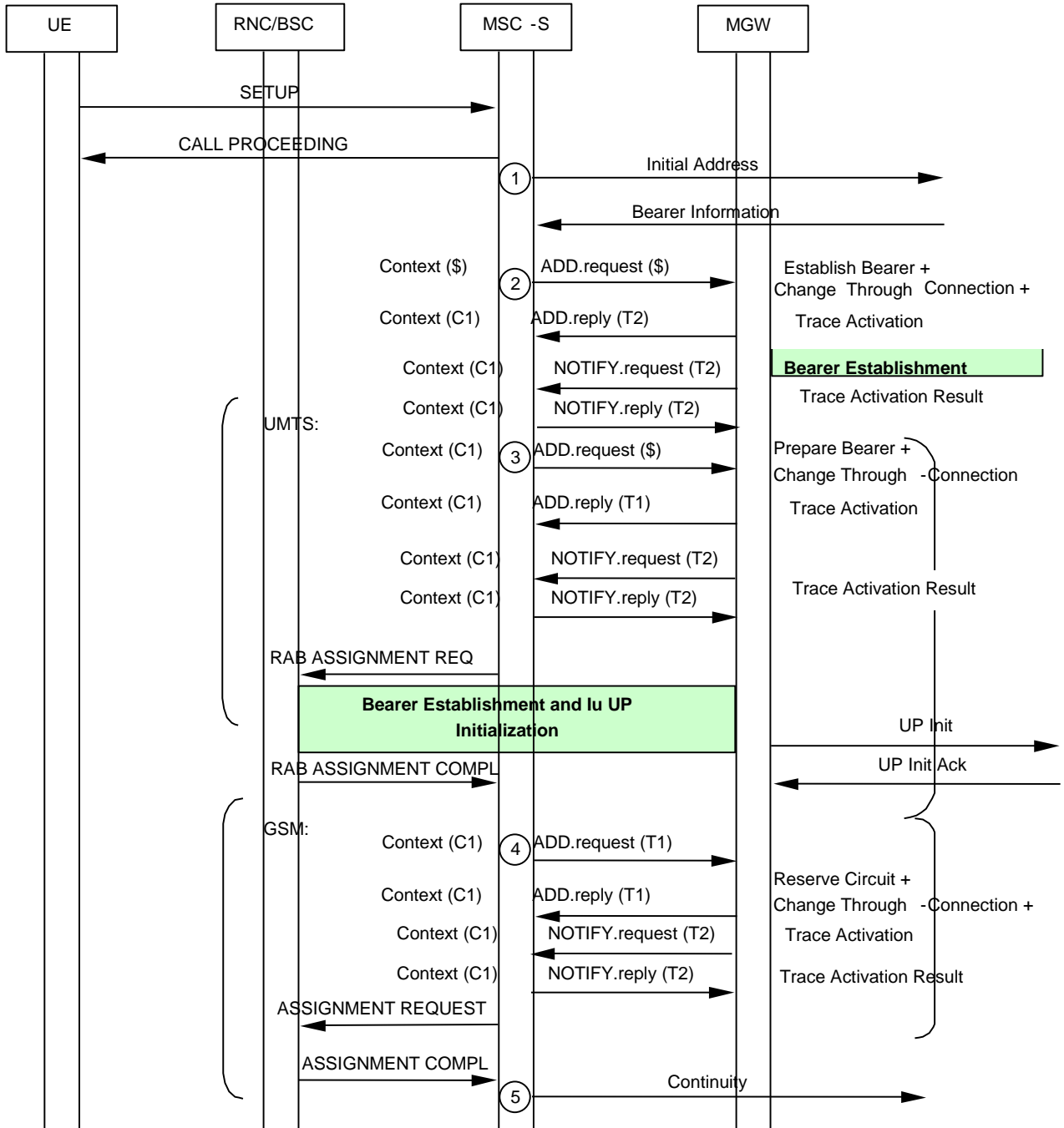
Figure 6.1.4.1 shows the network model for the mobile originating call. The "squared" line represents the call control signalling. The "dotted" line represents the bearer control signalling (not applicable in A/Gb mode for the A -interface) and the bearer. The MSC server seizes one context with two bearer terminations in the MGW. The bearer termination T1 is used for the bearer towards the RNC/BSC and the bearer termination T2 is used for the bearer towards the succeeding MGW.



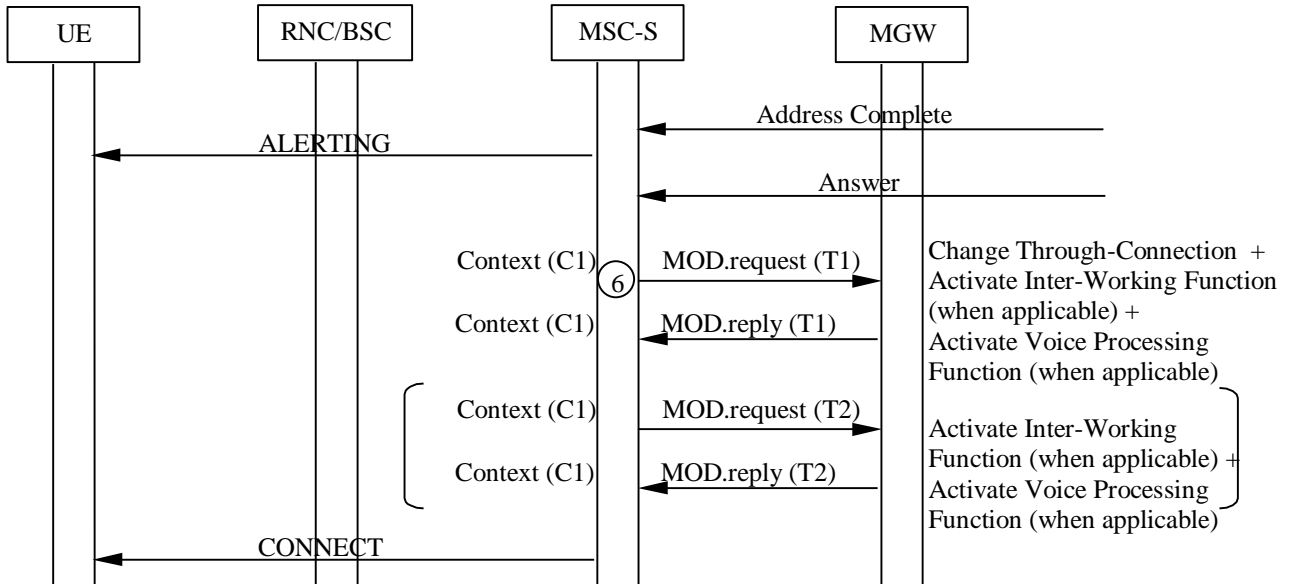
**Figure 6.1.4.1: Basic Mobile Originating Call, Forward Bearer Establishment with Trace Session Activation (network model)**

Figure 6.1.4.2 shows the message sequence chart example for the mobile originating call. In the example the MSC server activates the Trace Session to MGW when it request the creation of the incoming and outgoing termination with ADD request. MGW sends the Trace Session Activation result with NOTIFY request to MSC Server.





**Figure 6.1.4.2/1: Basic Mobile Originating Call, Forward Bearer Establishment with Trace Session Activation (message sequence chart)**



**Figure 6.1.4.2/2: Basic Mobile Originating Call, Forward Bearer Establishment with Trace Session Activation (message sequence chart continue)**

### 6.1.5 Originating Call Establishment for A interface over IP

If AoIP is supported by the MSC server, the Core Network side procedures described in 6.1.1 or 6.1.2 shall apply. For the access side termination, the exchange of IP addresses and UDP port numbers via call control procedures is described in this clause.

Before the MSC server sends the Assignment Request to the BSC, the MSC server requests the MGW to reserve an RTP bearer termination using the Reserve RTP Connection Point procedure. The MSC server requests the MGW to reserve an IP Address and UDP Port and also may indicate that the IP interface type is for AoIP. The MGW reserves the RTP termination and indicates the IP address and UDP port number to the MSC server. MSC server then requests access bearer assignment using the provided IP address and UDP Port. When MSC server receives the BSSMAP ASSIGNMENT COMPLETE message, it shall send the BSC IP address and UDP Port to the MGW Access bearer termination using the Configure RTP Connection Point procedure.

The sequence is shown in figure 6.1.5.1.

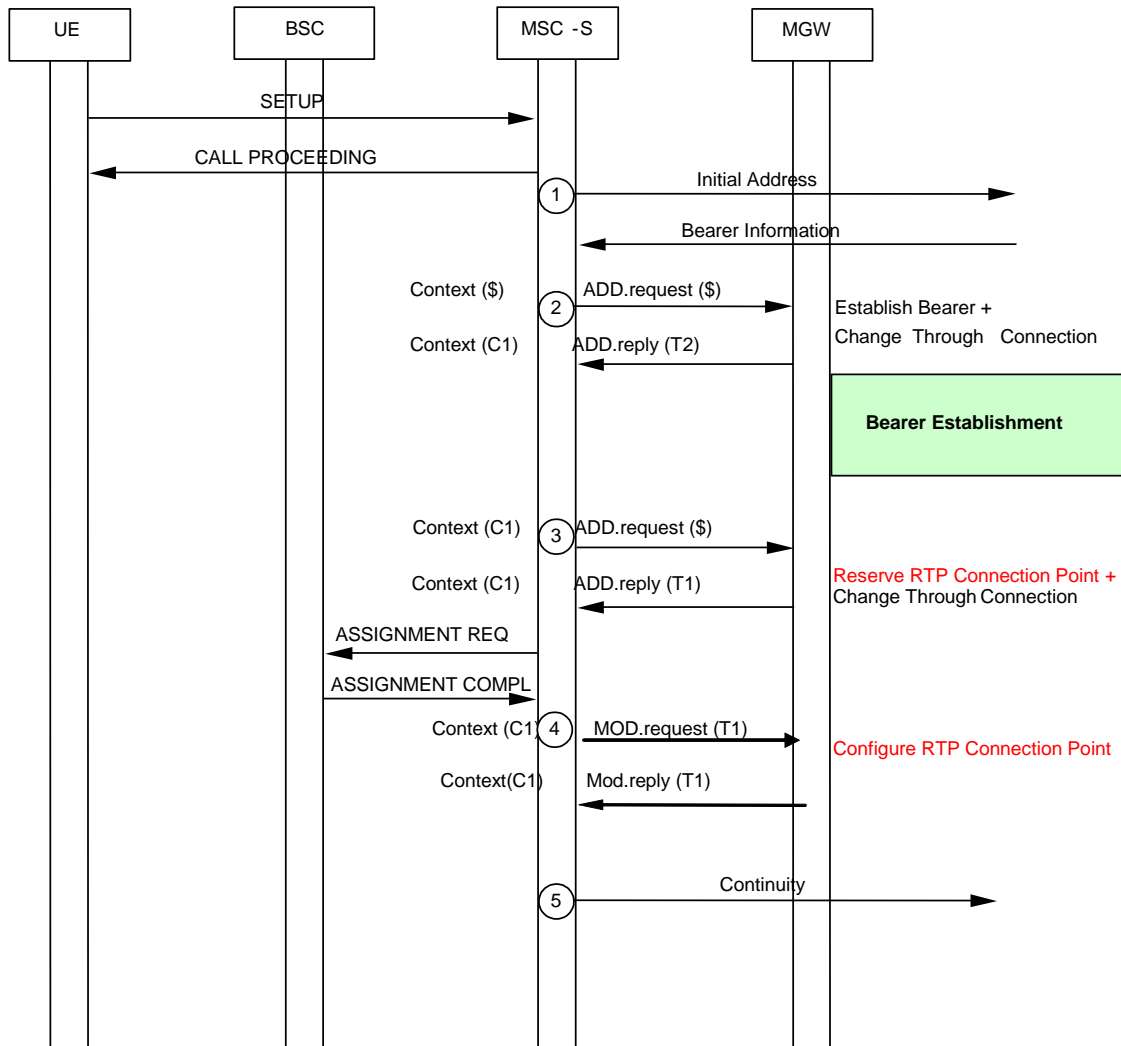


Figure 6.1.5.1: Originating Call Establishment for AoIP

## 6.2 Basic Mobile Terminating Call

### 6.2.1 Forward bearer establishment

The basic mobile terminating call shall be established in accordance with 3GPP TS 23.108 [18]. The following clauses describe the additional requirements for the bearer independent CS core network. If out-of-band transcoder control is applied for a speech call, it shall be performed in accordance with 3GPP TS 23.153 [3].

#### 6.2.1.1 GMSC server

##### 6.2.1.1.1 MGW selection

The GMSC server shall select an MGW for the bearer connection before it performs the incoming side bearer establishment or the outgoing side bearer establishment. This may happen either before sending the IAM or after receiving the Bearer Information message. If the GMSC server received an MGW-id from the preceding node and/or from the succeeding node, then it may use one of them for the MGW selection (bullet 1 or bullet 4 in figure 6.6).

**NOTE:** As an implementation option, if there is no need for the GMSC server to manipulate the bearer, the GMSC server may perform call control signalling without any associated MGW. In that case the bearer related information shall be passed transparently through the GMSC server.

### 6.2.1.1.2 Initial addressing

The GMSC server shall indicate in the IAM that forward bearer establishment is to be used. The GMSC server shall also indicate in the IAM that the Continuity message will follow if either of the following conditions is satisfied before sending the IAM:

1. the incoming IAM indicated that the Continuity message will follow, but no Continuity message has been received;
2. the GMSC server selected an MGW, but a notification of successful bearer establishment on the incoming side has not been received from the MGW.

The GMSC server shall provide the bearer characteristics to the succeeding node in the IAM. If the MGW is selected at an early stage the MGW-id may also be provided in the IAM (bullet 1 in figure 6.6).

### 6.2.1.1.3 Outgoing side bearer establishment

The GMSC server shall select bearer characteristics for the outgoing side bearer connection before it sends the IAM. After the GMSC server has received a bearer address and a binding reference in the Bearer Information message from the succeeding node the GMSC server requests the MGW to establish a bearer to the given destination MGW using the Establish Bearer procedure. The GMSC server shall provide the MGW with the bearer address, the binding reference and the bearer characteristics (bullet 4 in figure 6.6).

### 6.2.1.1.4 Incoming side bearer establishment

The GMSC server requests the MGW to prepare for the incoming side bearer establishment using the Prepare Bearer procedure. The GMSC server requests the MGW to provide a bearer address, a binding reference and to notify when the bearer is established (bullet 5 in figure 6.6). The GMSC server also provides the MGW with the bearer characteristics that was received from the preceding node in the IAM. After the MGW has replied with the bearer address and the binding reference, the GMSC server sends the Bearer Information message to the preceding node. The GMSC server may also include the MGW-id in the Bearer Information message (bullet 6 in figure 6.6).

NOTE: The incoming side bearer establishment may take place either before or after HLR interrogation.

### 6.2.1.1.5 Framing protocol initialisation

In 3GPP CS CN speech and data shall be carried using the Iu/Nb User Plane Protocol. The specification for the Iu UP protocol is defined in [20] and the Nb UP Protocol in [7] and [21]. The Iu/Nb UP Protocol is established through the CN in a forward direction. This is established independently of the bearer establishment direction. The MGW derives the forward direction from information sent by the MSC server within the Establish Bearer and Prepare Bearer procedures [6]. The notification of bearer establishment shall not be sent until the Iu/Nb UP has been initialised.

### 6.2.1.1.6 Through-Connection

During the Prepare Bearer and Establish Bearer procedures, the GMSC server will use the Change Through-Connection procedure to request the MGW to both-way through-connect the bearer termination (bullet 4 and bullet 5 in figure 6.6).

### 6.2.1.1.7 Confirmation of bearer establishment

If the IAM which was sent to the succeeding node indicated that the Continuity message will follow, the Continuity message shall be sent when both of the following conditions are satisfied:

1. Either:
  - a. The incoming IAM indicated that the Continuity message will follow, and a Continuity message has been received from the preceding node (bullet 8 in figure 6.6), or
  - b. The incoming IAM did not indicate that the Continuity message will follow;
2. Either:
  - a. The GMSC server has selected an MGW, and a notification of successful bearer establishment in the incoming side has been received from the MGW (bullet 7 in figure 6.6), or

- b. MGW selection is not required for this call.

#### 6.2.1.1.8 Voice Processing function

A voice processing function located on the MGW may be used to achieve desired acoustic quality on the bearer terminations. The GMSC server shall request the activation of the voice processing functions in the bearer terminations. For non-speech calls, the GMSC server has the ability to instruct the MGW to disable the voice processing functions (bullet 13 in figure 6.6). The voice activation request from the GMSC server to MGW may be issued as soon as bullet 8 in figure 6.6, and may be issued as late as bullet 13 in figure 6.6 as illustrated.

#### 6.2.1.1.9 Failure handling in GMSC server

If any procedure between the GMSC server and the MGW has not completed successfully or the GMSC server receives a Bearer Released procedure from the MGW, the call shall be cleared as described in clause 7.3, (G)MSC server initiated call clearing or in clause 7.4, MGW initiated call clearing. Alternatively, the GMSC server may only release the resources in the MGW that caused the failure, possibly select a new MGW for the bearer connection and continue the call establishment using new resources in the selected MGW.

#### 6.2.1.2 MSC server

##### 6.2.1.2.1 Paging

If the network side bearer establishment is delayed whilst the paging procedure is completed, the MSC server starts the Start\_Bearer\_Establishment timer when the paging procedure is started. The Start\_Bearer\_Establishment timer is stopped when the paging procedure is completed, or optionally when the Call Confirmed message is received in accordance with 3GPP TS 23.153 [3]. If the Start\_Bearer\_Establishment timer expires, the MSC server starts the network side bearer establishment.

##### 6.2.1.2.2 Call setup

The MSC server indicates to the UE in the SETUP message that early access bearer assignment is used in order to establish the bearer end-to-end before the UE starts alerting. The MSC server indicates to the UE in SETUP message that early access bearer assignment is used if either of the following conditions is satisfied before sending the SETUP message (bullet 2 in figure 6.6):

1. The incoming IAM indicated that the Continuity message will follow, but no Continuity message has been received;
2. A notification of successful bearer establishment in the network side has not been received from the MGW.

##### 6.2.1.2.3 MGW selection

The MSC server shall select an MGW for the bearer connection before it performs the network side bearer establishment or the access bearer assignment. This happens at latest after the UE has sent the Call Confirmed message. If the MSC server received an MGW-id from the preceding node, it may use this for the MGW selection (bullet 3 in figure 6.6). For GSM, if performing Service based handover (see 3GPP TS 48.008 [27]) the MSC Server may omit MGW selection at this time.

##### 6.2.1.2.4 Network side bearer establishment

The MSC server requests the MGW to prepare for the network side bearer establishment using the Prepare Bearer procedure. The MSC server requests the MGW to provide a bearer address, a binding reference and to notify when the bearer is established (bullet 3 in figure 6.6). The MSC server also provides the MGW with the bearer characteristics that was received from the preceding node in the IAM. After the MGW has replied with the bearer address and the binding reference, the MSC server provides the Bearer Information message to the preceding node. The MSC server may also provide the MGW-id in the Bearer Information message.

##### 6.2.1.2.5 Access bearer assignment

The access bearer assignment shall be started only when both of the following conditions are satisfied:

1. Either:
  - a. The incoming IAM indicated that the Continuity message will follow, and a Continuity message has been received from the preceding node, or
  - b. The incoming IAM did not indicate that the Continuity message will follow;
2. A notification of successful bearer establishment in the network side has been received from the MGW (bullet 6 in figure 6.6).

The MSC server shall select bearer characteristics for the access bearer.

For the access bearer assignment in UMTS the MSC server requests the MGW to prepare for the access bearer establishment using the Prepare Bearer procedure. The MSC server requests the MGW to provide a bearer address and a binding reference, provides the MGW with the bearer characteristics and requests notification that the bearer can be modified. For speech calls, the MSC server shall provide the MGW with the speech coding information and conditionally GTT related information in accordance with 3GPP TS 23.226 [28] for the bearer. For a non-speech call the MSC server also provides the MGW with a PLMN Bearer Capability [4]. After the MGW has replied with the bearer address and the binding reference the MSC server requests the access bearer assignment using the provided bearer address and the binding reference (bullet 9 in figure 6.6) in accordance with 3GPP TS 25.413 [26]. The MSC shall only be notified by the MGW using the Bearer Modification Support procedure if the existing link characteristics of the access bearer can be modified at a later stage, see subclause 13.18.1.

For GERAN Iu mode the MSC Server receives the GERAN capabilities within the RANAP INITIAL UE MESSAGE, indicating the services (e.g. for CS speech services the supported codec types and, for an adaptive codec type, the supported codec modes (for definition see [27])), which will be available at the RAB establishment procedure. The MSC server shall take the indicated GERAN capabilities into account as well as the received MS capabilities when negotiating a service. Additionally, when requesting the access bearer assignment the MSC server shall indicate to the GERAN the selected service (e.g. selected codec type). The MSC server shall not set codec information in the NAS Synchronisation Indicator (see [4]). Instead it shall set codec information in the GERAN BSC container.

For GSM, before the MSC server starts the access bearer assignment, the MSC server uses the Reserve Circuit procedure to seize a TDM circuit. For a non-speech call the MSC server also provides the MGW with a PLMN Bearer Capability [4] and a GSM channel coding. After the MGW has replied the TDM circuit seizure the MSC server requests access bearer assignment (bullet 10 in figure 6.6) in accordance with 3GPP TS 48.008 [27]. If performing Service based handover (see 3GPP TS 48.008 [27]) the MSC Server may omit to perform Reserve Circuit procedure.

#### 6.2.1.2.6 Framing protocol initialisation

In 3GPP CS CN speech and data shall be carried using the Iu/Nb User Plane Protocol. The specification for the Iu UP protocol is defined in [20] and the Nb UP Protocol in [7] and [21]. The Iu/Nb UP Protocol is established through the CN in a forward direction. This is established independently of the bearer establishment direction. The MGW derives the forward direction from information sent by the MSC server within the Establish Bearer and Prepare Bearer procedures [6]. The notification of bearer establishment shall not be sent until the Nb UP has been initialised.

#### 6.2.1.2.7 Called party alerting

For a speech call, when the MSC server receives an Alerting message, it requests the MGW to provide a ringing tone to the calling party using the Send Tone procedure (bullet 11 in figure 6.6).

NOTE: Other kind of tones may be provided to the calling party at an earlier stage of the call establishment.

#### 6.2.1.2.8 Called party answer

For a speech call, when the MSC server receives a Connect message, it requests the MGW to stop providing the ringing tone to the calling party using the Stop Tone procedure (bullet 12 in figure 6.6).

#### 6.2.1.2.9 Through-Connection

During the Prepare Bearer and Reserve Circuit procedures, the MSC server will use the Change Through-Connection procedure to request the MGW to through-connect the bearer terminations so that the bearer will be not through-connected (bullet 3, and bullet 9 or 10 in figure 6.6).

When the MSC server receives the Connect message, it requests the MGW to both-way through-connect the bearer using the Change Through-Connection procedure (bullet 12 in figure 6.6).

#### 6.2.1.2.10 Interworking function

The MGW may use an interworking function that is based on the PLMN Bearer Capability [4] of the bearer termination. The activation of the possible interworking function in both bearer terminations will be requested by the MSC server at reception of the Connect message using the Activate Interworking Function procedure (bullet 12 in figure 6.6).

#### 6.2.1.2.11 Codec handling

The MGW may include a speech transcoder based upon the speech coding information provided to each bearer termination.

#### 6.2.1.2.12 Voice Processing function

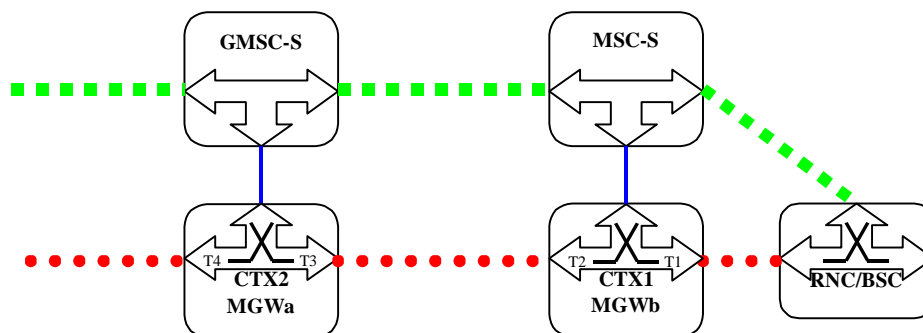
A voice processing function located on the MGW may be used to achieve desired acoustic quality on the bearer terminations. The MSC server shall request the activation of the voice processing functions in the bearer terminations. For non-speech calls, the MSC server has the ability to instruct the MGW to disable the voice processing functions (bullet 12 in figure 6.6).

#### 6.2.1.2.13 Failure handling in MSC server

If any procedure between the MSC server and the MGW is not completed successfully, the call shall be cleared as described in clause 7.3, (G)MSC server initiated call clearing. Alternatively, the MSC server may only release the resources in the MGW that caused the failure, possibly select a new MGW for the bearer connection and continue the call establishment using new resources in the selected MGW.

#### 6.2.1.2.14 Example

Figure 6.5 shows the network model for the basic mobile terminating call. The "squared" line represents the call control signalling. The "dotted" line represents the bearer control signalling (not applicable in A/Gb mode for the A-interface). The MSC server seizes one context with two bearer terminations in MGWb. The bearer termination T1 is used for the bearer towards the RNC/BSC and the bearer termination T2 is used for the bearer towards the GMSC server selected MGWa. The GMSC server seizes one context with two bearer terminations in MGWa. The bearer termination T3 is used for the bearer towards the MSC server selected MGWb and the bearer termination T4 is used for the bearer towards the preceding MGW.



**Figure 6.5: Basic Mobile Terminating Call Forward Bearer Establishment (network model)**

Figure 6.6 shows the message sequence example for the basic mobile terminating call. In the example the GMSC server requests seizure of the outgoing side bearer termination and establishment of the bearer when the Bearer Information message is received from the MSC server. After the outgoing side bearer termination is seized the GMSC server requests seizure of the incoming side bearer termination. The MGW sends a notification of an established incoming side bearer. The MSC server requests seizure of the network side bearer termination when Call Confirmed message is

received from the UE. The MGW sends a notification of an established network side bearer. When the Continuity message is received from the GMSC server, the MSC server requests seizure of the access side bearer termination. For a speech call the MSC server requests MGW to provide a ringing tone to the calling party at alerting. At answer the MSC server requests MGW to both-way through-connect the bearer. For a speech call the MSC server requests MGW to stop the ringing tone to the calling party at answer. When the MSC server receives an answer indication, it shall request the possible activation of the interworking function in both bearer terminations. The (G)MSC server shall request the possible activation of the voice processing functions for the bearer terminations.

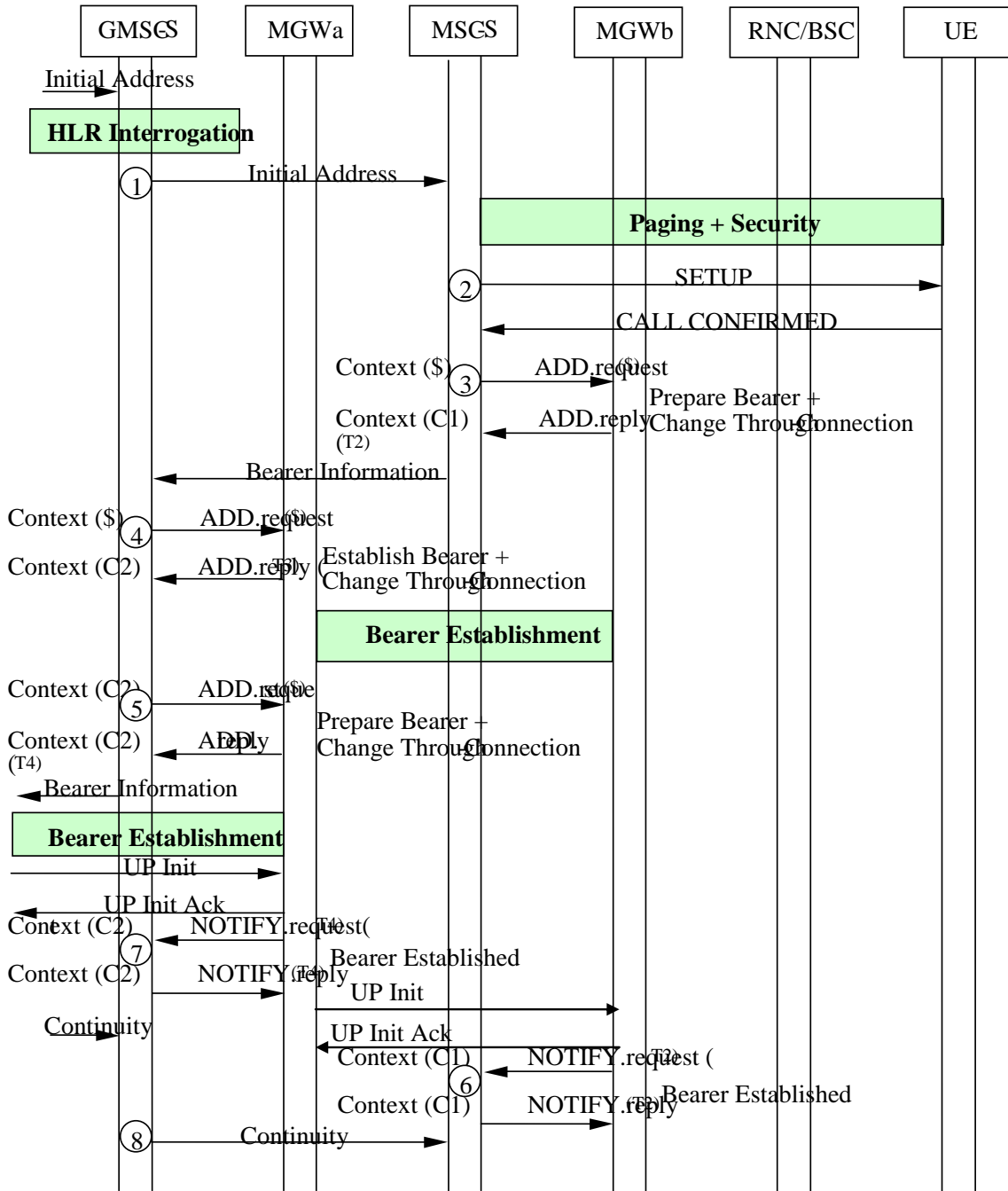


Figure 6.6/1: Basic Mobile Terminating Call, Forward Bearer Establishment (message sequence chart)



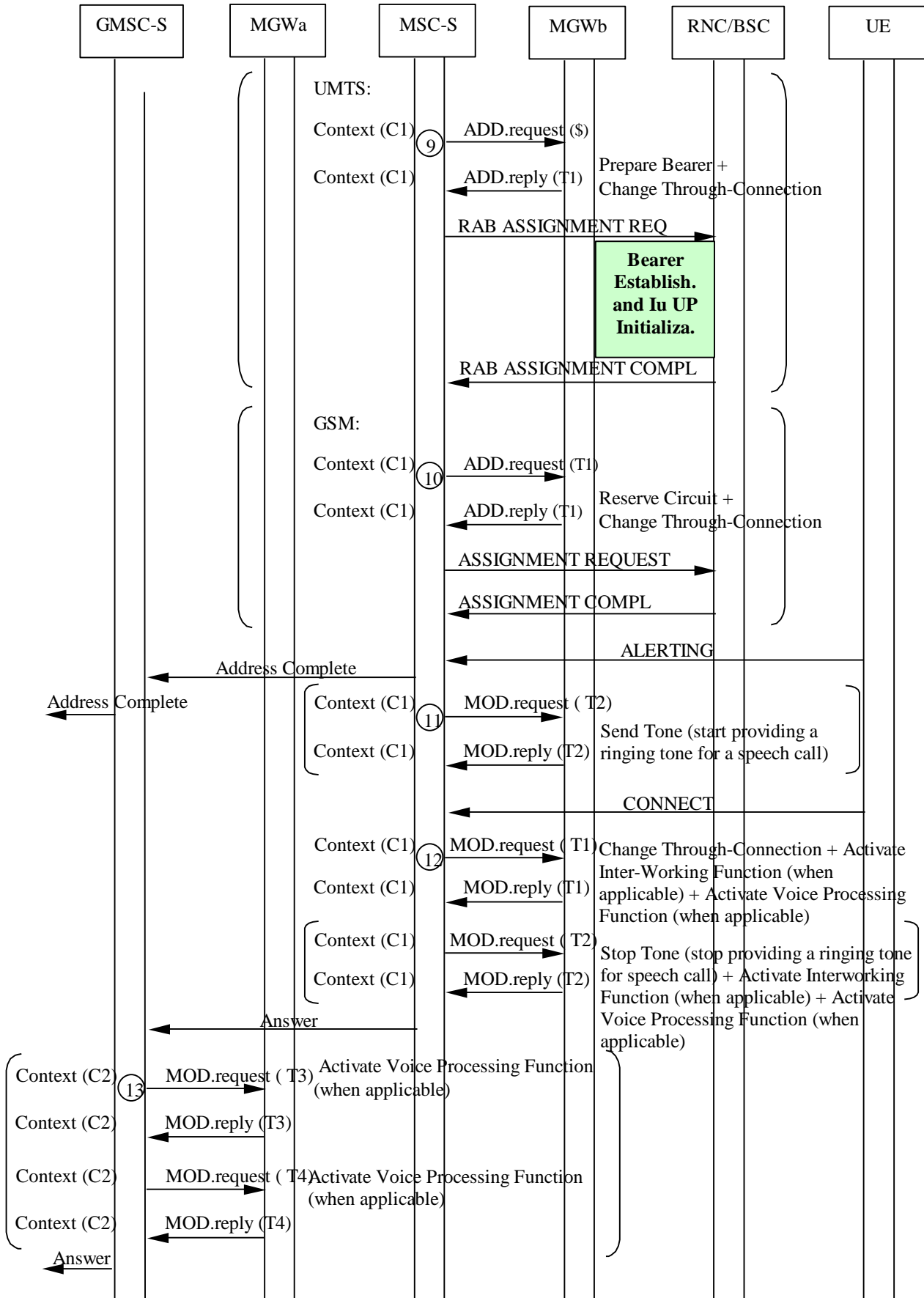


Figure 6.6/2: Basic Mobile Terminating Call, Forward Bearer Establishment (message sequence chart continue)

## 6.2.2 Backward bearer establishment

The basic mobile terminating call shall be established in accordance with 3GPP TS 23.108 [4]. The following clauses describe the additional requirements for the bearer independent CS core network. If out-of-band transcoder control is applied for a speech call, it shall be performed in accordance with 3GPP TS 23.153 [3].

### 6.2.2.1 GMSC server

#### 6.2.2.1.1 MGW selection

The GMSC server shall select an MGW for the bearer connection before it performs the incoming side bearer establishment or the outgoing side bearer establishment. This happens before sending the IAM. If the GMSC server received an MGW-id from the preceding node, it may use this for the MGW selection (bullet 1 in figure 6.8).

NOTE 1: As an implementation option, if there is no need for the GMSC server to manipulate the bearer, the GMSC server may perform call control signalling without any associated MGW. In that case the bearer related information shall be provided transparently through the GMSC server.

#### 6.2.2.1.2 Outgoing side bearer establishment

The GMSC server shall select bearer characteristics for the outgoing side bearer connection before it sends the IAM. The GMSC server requests the MGW to prepare for the outgoing side bearer establishment using the Prepare Bearer procedure. The GMSC server requests the MGW to provide a bearer address and a binding reference, and provides the MGW with the bearer characteristics (bullet 3 in figure 6.8). After the MGW has replied with the bearer address and the binding reference, the GMSC server sends the IAM to the succeeding node.

#### 6.2.2.1.3 Initial addressing

The GMSC server shall indicate in the IAM that backward bearer establishment is to be used. The GMSC server shall also indicate in the IAM that the Continuity message will follow if either of the following conditions is satisfied before sending the IAM:

1. The incoming IAM indicated that the Continuity message will follow, but no Continuity message has been received, or
2. The GMSC server selected an MGW, but a notification of successful bearer establishment on the incoming side has not been received from the MGW.

The GMSC server shall provide the bearer characteristics to the succeeding node in the IAM. The MGW -id may also be provided in the IAM (bullet 4 in figure 6.8).

#### 6.2.2.1.4 Incoming side bearer establishment

The GMSC server requests the MGW to establish a bearer to the given destination MGW and to notify when the bearer is established using the Establish Bearer procedure. The GMSC server provides the MGW with the bearer address, the binding reference and the bearer characteristics that were received from the preceding node in the IAM (bullet 1 in figure 6.8).

NOTE 2: The incoming side bearer establishment may take place either before or after HLR interrogation.

#### 6.2.2.1.5 Framing protocol initialisation

In 3GPP CS CN speech and data shall be carried using the Iu/Nb User Plane Protocol. The specification for the Iu UP protocol is defined in [20] and the Nb UP Protocol in [7] and [21]. The Iu/Nb UP Protocol is established through the CN in a forward direction. This is established independently of the bearer establishment direction. The MGW derives the forward direction from information sent by the MSC server within the Establish Bearer and Prepare Bearer procedures [6]. The notification of bearer establishment shall not be sent until the Iu/Nb UP has been initialised

### 6.2.2.1.6 Through-Connection

During the Prepare Bearer and Establish Bearer procedures, the GMSC server will use the Change Through-Connection procedure to request the MGW to both-way through-connect the bearer termination (bullet 1 and bullet 3 in figure 6.8).

### 6.2.2.1.7 Confirmation of bearer establishment

If the IAM which was sent to the succeeding node indicated that the Continuity message will follow, the Continuity message shall be sent when both of the following conditions are satisfied:

1. Either:
  - a. The incoming IAM indicated that the Continuity message will follow, and a Continuity message has been received from the preceding node, or
  - b. The incoming IAM did not indicate that the Continuity message will follow;
2. Either:
  - a. The GMSC server has selected an MGW, and a notification of successful bearer establishment in the incoming side has been received from the MGW (bullet 2 in figure 6.8), or
  - b. MGW selection is not required for this call.

### 6.2.2.1.8 Voice Processing function

A voice processing function located on the MGW may be used to achieve desired acoustic quality on the bearer terminations. The (G)MSC server shall request the activation of voice processing functions in the bearer terminations. For non-speech calls, the GMSC server has the ability to instruct the MGW to disable the voice processing functions (bullet 12 in figure 6.8). The voice activation request from the GMSC server to MGW may be issued as soon as bullet 4 in figure 6.8, and may be issued as late as bullet 12 in figure 6.8 as illustrated.

### 6.2.2.1.9 Failure handling in GMSC server

If any procedure between the MSC server and the MGW is not completed successfully or the GMSC server receives a Bearer Released procedure from the MGW, the call shall be cleared as described in clause 7.3, (G)MSC server initiated call clearing or in clause 7.4, MGW initiated call clearing. Alternatively, the GMSC server may only release the resources in the MGW that caused the failure, possibly select a new MGW for the bearer connection and continue the call establishment using new resources in the selected MGW.

## 6.2.2.2 MSC server

### 6.2.2.2.1 Paging

If the network side bearer establishment is delayed whilst the paging procedure is completed, the MSC server starts the Start\_Bearer\_Establishment timer when the paging procedure is started. The Start\_Bearer\_Establishment timer is stopped when the paging procedure is completed, or optionally when the Call Confirmed message is received in accordance with 3GPP TS 23.153 [3]. If the Start\_Bearer\_Establishment timer expires, the MSC server starts the network side bearer establishment.

### 6.2.2.2.2 Call setup

The MSC server indicates to the UE in the SETUP message that early access bearer assignment is used in order to establish the bearer end-to-end before the UE starts alerting. The MSC server indicates to the UE in the SETUP message that early access bearer assignment is used, if and only if, either of the following conditions are satisfied before sending the SETUP message (bullet 5 in figure 6.8):

1. If the IAM indicated that the Continuity message will follow, but no Continuity message has been received.
2. A notification of successful bearer establishment in the network side has not been received from the MGW.

### 6.2.2.2.3 MGW selection

The MSC server shall select an MGW for the bearer connection before it performs the network side bearer establishment or the access bearer assignment. This happens at latest after the UE has sent the Call Confirmed message. If the MSC server received an MGW -id from the preceding node, it may use this for the MGW selection (bullet 6 in figure 6.8). For GSM, if performing Service based handover (see 3GPP TS 48.008 [27]) the MSC Server may omit MGW selection at this time.

### 6.2.2.2.3 Network side bearer establishment

The MSC server requests the MGW to establish a bearer to the given destination MGW and to notify when the bearer is established using the Establish Bearer procedure. The MSC server provides the MGW with the bearer address, the binding reference and the bearer characteristics that were received from the preceding node in the IAM (bullet 6 in figure 6.8).

### 6.2.2.2.4 Access bearer assignment

The access bearer assignment shall be started only when both of the following conditions are satisfied:

1. Either:
  - a. The incoming IAM indicated that the Continuity message will follow, and a Continuity message has been received from the preceding node, or
  - b. The incoming IAM did not indicate that the Continuity message will follow;
2. A notification of successful bearer establishment in the network side has been received from the MGW (bullet 7 in figure 6.8).

The MSC server shall select bearer characteristics for the access bearer.

For the access bearer assignment in UTRAN the MSC server requests the MGW to prepare for the access bearer establishment using the Prepare Bearer procedure. The MSC server requests the MGW to provide a bearer address and a binding reference, provides the MGW with the bearer characteristics and requests notification that the bearer can be modified. For speech calls, the MSC server shall provide the MGW with the speech coding information and conditionally GTT related information in accordance with 3GPP TS 23.226 [28] for the bearer. For a non-speech call the MSC server also provides the MGW with a PLMN Bearer Capability [4]. After the MGW has replied with the bearer address and the binding reference the MSC server requests the access bearer assignment using the provided bearer address and the binding reference (bullet 8 in figure 6.8) in accordance with 3GPP TS 25.413 [26]. The MSC shall only be notified by the MGW using the Bearer Modification Support procedure if the existing link characteristics of the access bearer can be modified at a later stage, see subclause 13.18.1.

For GERAN Iu mode the MSC Server receives the GERAN capabilities within the RANAP INITIAL UE MESSAGE, indicating the services (e.g. for CS speech services the supported codec types and, for an adaptive codec type, the supported codec modes (for definition see [27])), which will be available at the RAB establishment procedure. The MSC server shall take the indicated GERAN capabilities into account as well as the received MS capabilities when negotiating a service. Additionally, when requesting the access bearer assignment the MSC server shall indicate to the GERAN the selected service (e.g. selected codec type). The MSC server shall not set codec information in the NAS Synchronisation Indicator (see [4]). Instead it shall set codec information in the GERAN BSC container..

For GSM, before the MSC server starts the access bearer assignment, the MSC server uses the Reserve Circuit procedure to seize a TDM circuit. For a non-speech call the MSC server also provides the MGW with a PLMN Bearer Capability [4] and a GSM channel coding. After the MGW has replied the TDM circuit seizure the MSC server requests access bearer assignment (bullet 9 in figure 6.8) in accordance with 3GPP TS 48.008 [27]. If performing Service based handover (see 3GPP TS 48.008 [27]) the MSC Server may omit to perform Reserve Circuit procedure.

### 6.2.2.2.5 Framing protocol initialisation

In 3GPP CS CN speech and data shall be carried using the Iu/Nb User Plane Protocol. The specification for the Iu UP protocol is defined in [20] and the Nb UP Protocol in [7] and [21]. The Iu/Nb UP Protocol is established through the CN in a forward direction. This is established independently of the bearer establishment direction. The MGW derives the forward direction from information sent by the MSC server within the Establish Bearer and Prepare Bearer procedures [6]. The notification of bearer establishment shall not be sent until the Nb UP has been initialised.

#### 6.2.2.2.6 Called party alerting

For a speech call, when the MSC server receives an Alerting message, it requests the MGW to provide a ringing tone to the calling party using the Send Tone procedure (bullet 10 in figure 6.8).

NOTE: Other kind of tones may be provided to the calling party at an earlier stage of the call establishment.

#### 6.2.2.2.7 Called party answer

For a speech call, when the MSC server receives a Connect message, it requests the MGW to stop providing the ringing tone to the calling party using the Stop Tone procedure (bullet 11 in figure 6.8).

#### 6.2.2.2.8 Through-Connection

During any one of the Prepare Bearer, Reserve Circuit and Establish Bearer procedures, the MSC server will use the Change Through-Connection procedure to request the MGW to through-connect the bearer terminations so that the bearer will be not through-connected (bullet 6, and bullet 8 or 9 in figure 6.8).

When the MSC server receives the Connect message, it requests the MGW to both-way through-connect the bearer using the Change Through-Connection procedure (bullet 11 in figure 6.8).

#### 6.2.2.2.9 Interworking function

The MGW may use an interworking function that is based on the PLMN Bearer Capability [4] of the bearer termination. The activation of the possible interworking function in both bearer terminations will be requested by the MSC server at reception of the Connect message using the Activate Interworking Function procedure (bullet 11 in figure 6.8).

#### 6.2.2.2.10 Codec handling

The MGW may include a speech transcoder based upon the speech coding information provided to each bearer termination.

#### 6.2.2.2.11 Voice Processing function

A voice processing function located on the MGW may be used to achieve desired acoustic quality on the bearer terminations. The MSC server shall request the activation of the voice processing functions in the bearer terminations. For non-speech calls, the MSC server has the ability to instruct the MGW to disable the voice processing functions (bullet 11 in figure 6.8).

#### 6.2.2.2.12 Failure handling in MSC server

If any procedure between the MSC server and the MGW is not completed successfully or the MSC server receives a Bearer Released procedure from the MGW, the call shall be cleared as described in clause 7.3, (G)MSC server initiated call clearing or in clause 7.4, MGW initiated call clearing. Alternatively, the MSC server may only release the resources in the MGW that caused the failure, possibly select a new MGW for the bearer connection and continue the call establishment using new resources in the selected MGW.

#### 6.2.2.2.13 Example

Figure 6.7 shows the network model for the basic mobile terminating call. The "squared" line represents the call control signalling. The "dotted" line represents the bearer control signalling (not applicable in A/Gb mode for the A-interface) and the bearer. The MSC server seizes one context with two bearer terminations in MGWb. The bearer termination T1 is used for the bearer towards the RNC/BSC and the bearer termination T2 is used for the bearer towards the GMSC server selected MGWa. The GMSC server seizes one context with two bearer terminations in MGWa. The bearer termination T3 is used for the bearer towards the MSC server selected MGWb and the bearer termination T4 is used for the bearer towards the preceding MGW.

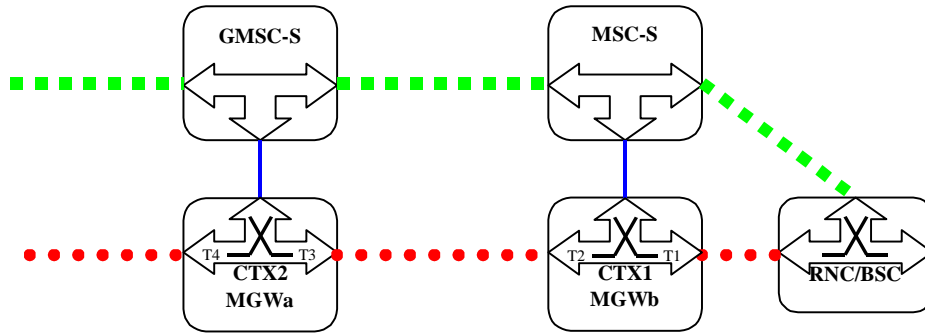


Figure 6.7: Basic Mobile Terminating Call, Backward Bearer Establishment (network model)

Figure 6.8 shows the message sequence example for the basic mobile terminating call. In the example the GMSC server requests seizure of the incoming side bearer termination and establishment of the bearer first. After a notification of incoming side bearer establishment has been received from the MGW, the GMSC server requests seizure of the outgoing side bearer termination. The MSC server requests seizure of the network side bearer termination and establishment of the bearer when the Call Confirmed message is received from the UE. After a notification of the network side bearer establishment has been received from the MGW the MSC server requests seizure of the access side bearer termination. For a speech call, When the MSC server receives an alerting message, it requests MGW to provide a ringing tone to the calling party. When the MSC server receives an answer indication, it requests MGW to both-way through-connect the bearer. For a speech, when the MSC server receives an answer indication, it requests MGW to stop the ringing tone to the calling party and requests the possible activation of the interworking function in both bearer terminations. The (G)MSC server shall request the possible activation of the voice processing functions for the bearer terminations.

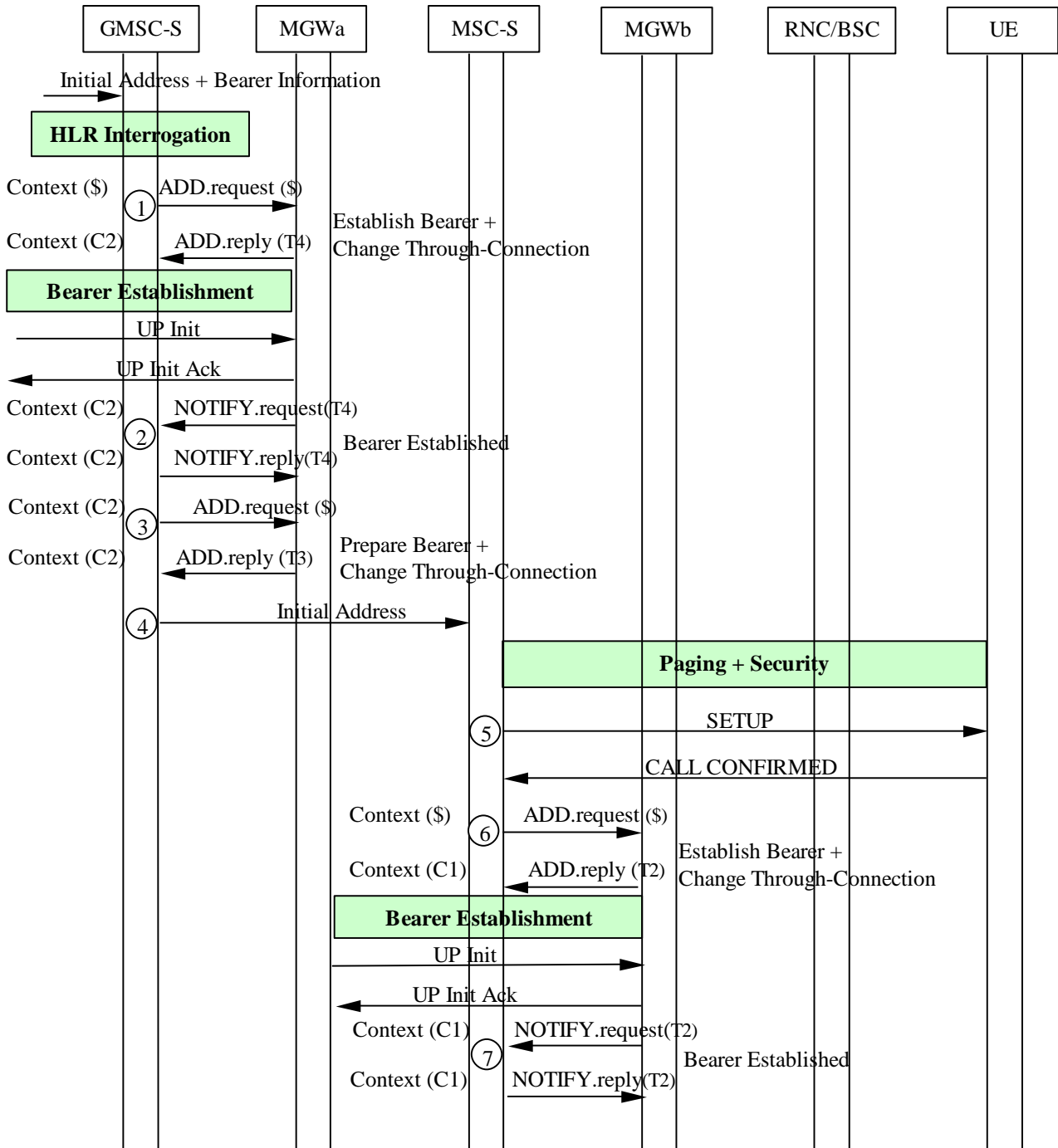


Figure 6.8/1: Basic Mobile Terminating Call, Backward Bearer Establishment (message sequence chart)

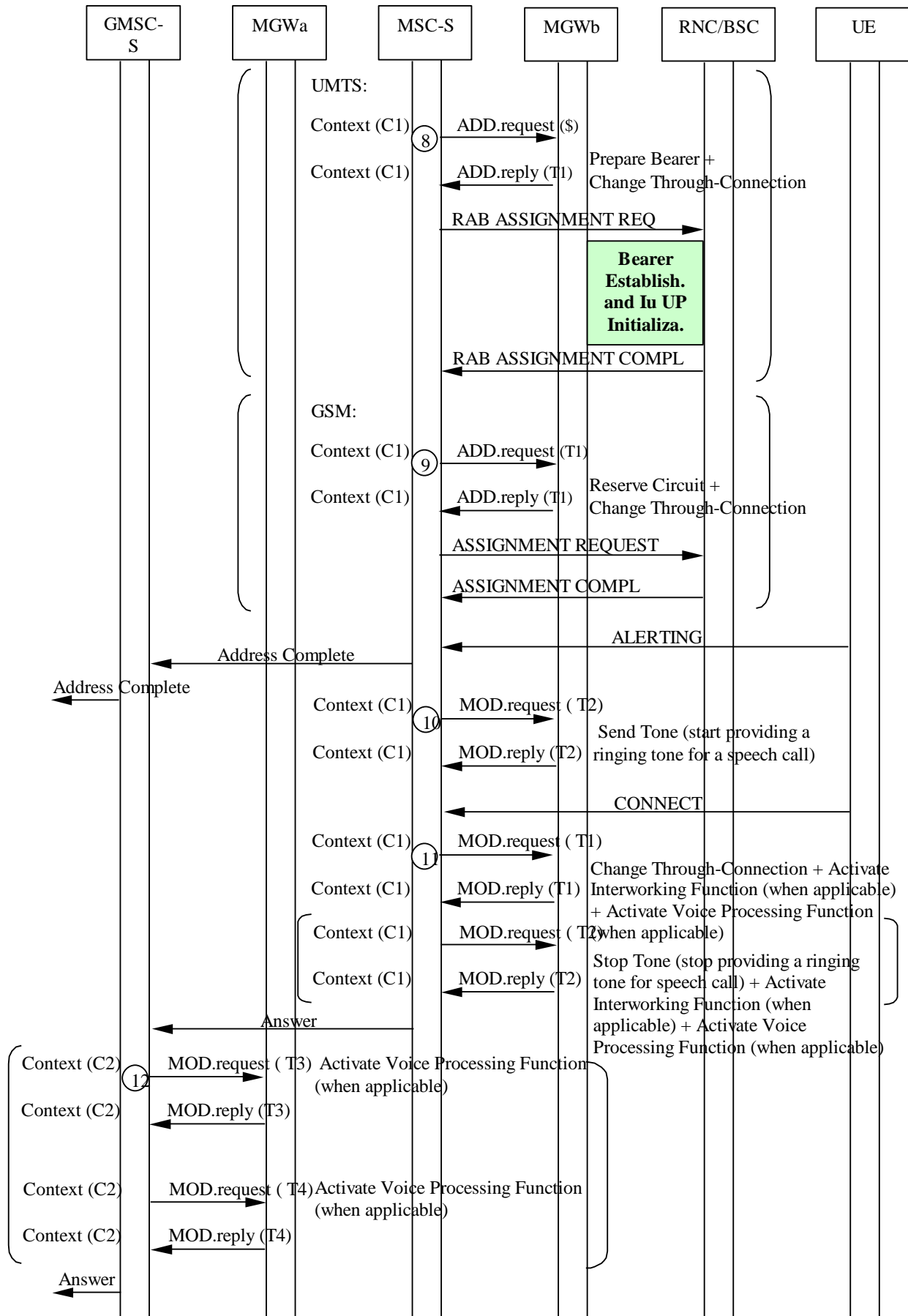


Figure 6.8/2: Basic Mobile Terminating Call, Backward Bearer Establishment (message sequence chart continue)



### 6.2.3 Terminating Call Establishment For Iu Interface on IP

If IuCS on IP is supported by the MSC server, the Core Network side procedures described in 6.2.1 or 6.2.2 shall apply. For the access bearer termination, the exchange of IP addresses via call control procedures is described in this clause.

Before the MSC server starts the access bearer assignment, the MSC server requests the MGW to prepare for the access bearer using the Prepare\_IP\_Transport procedure. The MSC server requests the MGW to provide an IP Transport Address and UDP Port and provides the MGW with the bearer characteristics. For speech calls, the MSC server shall provide the MGW with the speech coding information and conditionally GTT related information in accordance with 3GPP TS 23.226 [28]. For a non-speech call the MSC server also provides the MGW with a PLMN Bearer Capability [4]. After the MGW has replied with the IP address and UDP Port the MSC server requests access bearer assignment using the provided IP address and UDP Port in accordance with 3GPP TS 25.413 [26]. The IP addresses and UDP Ports of the MGW and the RNC are exchanged via the RANAP procedures. If the bearer transport is IP and IuUP mode is Transparent, when the MSC receives the RANAP RAB assignment response it shall send the RNC IP address and UDP Port to the MGW Access bearer termination using the Modify\_IP\_Transport\_Address procedure.

If the bearer transport is IP and IuUP mode is Support, the MGW shall use the source IP address and UDP Port of the IuUP Init packet received from the radio access network as the destination address for subsequent downlink packets.

The sequence is shown in figure 6.2.3/1.

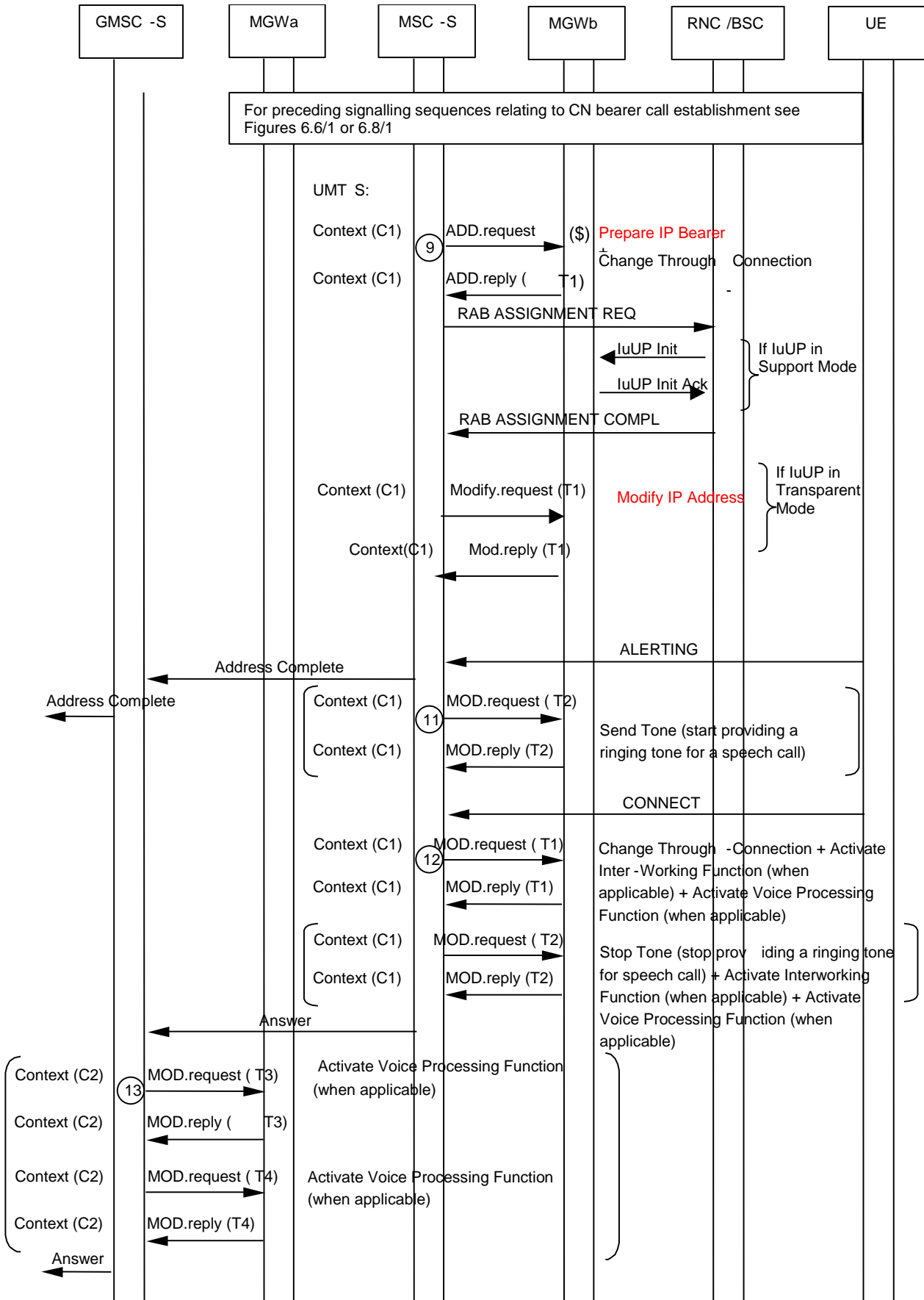


Figure 6.2.3/1 Terminating Call Establishment For Iu Interface on IP

### 6.2.4 Terminating Call Establishment For A Interface over IP

If AoIP is supported by the MSC server, the Core Network side procedures described in 6.2.1 or 6.2.2 shall apply. For the access side termination, the exchange of IP addresses via call control procedures is described in this clause.

Before the MSC server sends the Assignment Request to the BSC, the MSC server requests the MGW to reserve an RTP bearer termination using the Reserve RTP Connection Point procedure. The MSC server requests the MGW to reserve an IP Address and UDP Port and also may indicate that the IP interface type is for A interface over IP. The MGW reserves the AoIP termination and indicates the IP address and UDP port number to the MSC server. MSC server then requests access bearer assignment using the provided IP address and UDP Port. When MSC server receives the BSSMAP ASSIGNMENT COMPLETE message, it shall send the BSC IP address and UDP Port to the MGW Access bearer termination using the Configure RTP Connection Point procedure.

The sequence is shown in figure 6.2.3/1.

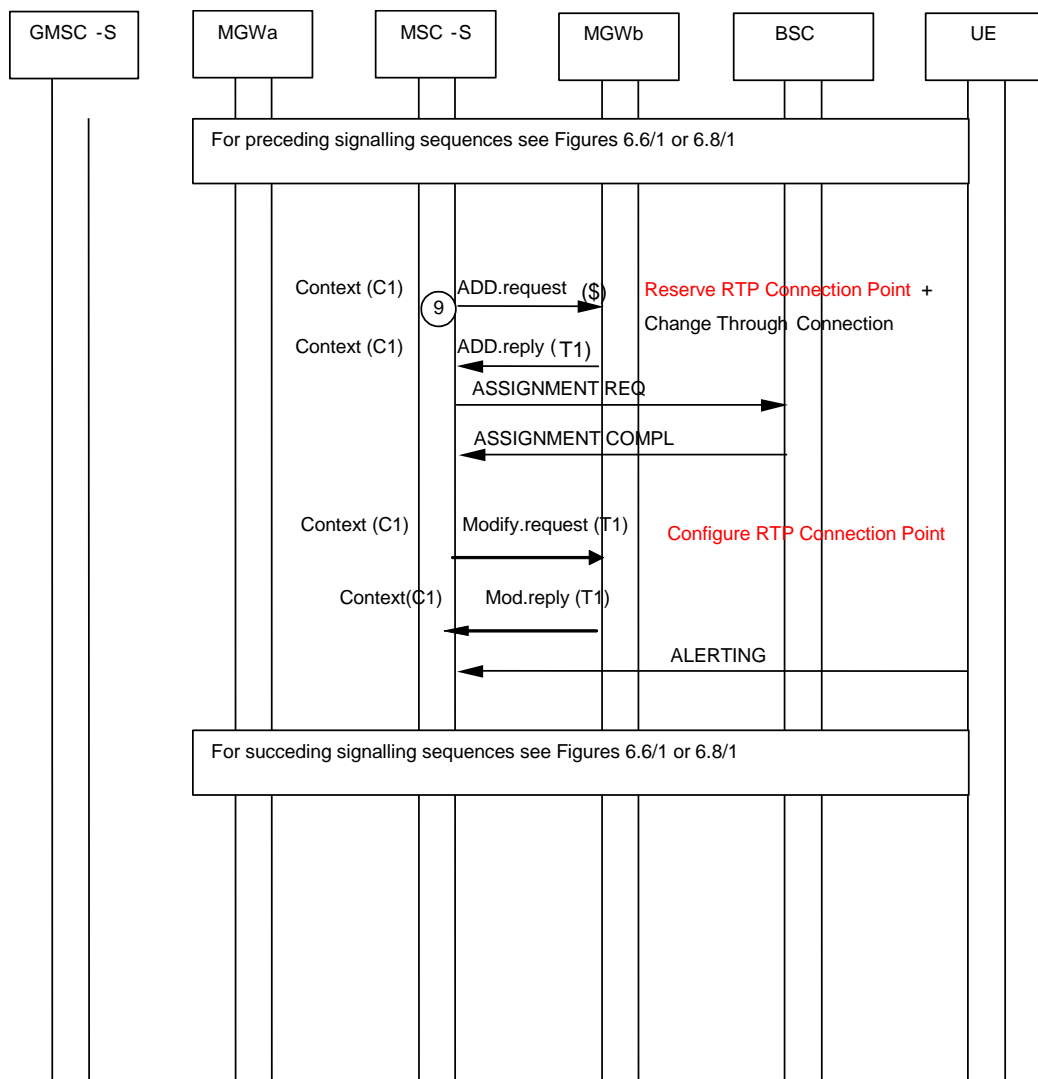


Figure 6.2.3/1 Terminating Call Establishment For AoIP

## 7 Call Clearing

NOTE: All message sequence charts in this clause are examples. All valid call establishment message sequences can be derived from the example message sequences and associated message pre-conditions.

## 7.1 Network Initiated

The terms "incoming" and "outgoing" in the following text refers to the direction of propagation of the Release message, not to the direction of establishing the original call.

### 7.1.1 GMSC server

#### 7.1.1.1 Call clearing from the incoming side

Once the Release message has been received from the preceding node, the GMSC server releases any MGW allocated resources for the incoming side. If any resources were seized in the MGW, the GMSC server shall use the Release Bearer and Release Termination procedures to indicate to the MGW to remove the incoming side bearer termination and that the bearer can be released towards the preceding MGW. After the resources in the MGW are released the GMSC server sends the Release Complete message to the preceding node.

#### 7.1.1.2 Call clearing to the outgoing side

The GMSC server sends the Release message to the succeeding node. Once the succeeding node has sent the Release Complete message, the GMSC server releases any MGW allocated resources for the outgoing side. If any resources were seized in the MGW, the GMSC server shall use the Release Bearer and Release Termination procedures to indicate to the MGW to remove the outgoing side bearer termination and that the bearer can be released towards the succeeding MGW.

### 7.1.2 MSC server

The network initiated call clearing shall be performed in accordance with 3GPP TS 23.108 [18]. The following clauses describe the additional requirements for the bearer independent CS core network.

#### 7.1.2.1 Call clearing from the network side

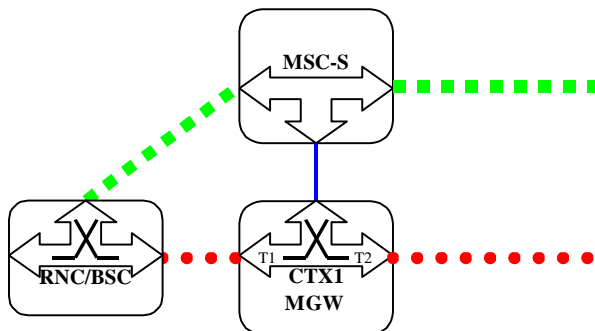
Once the Release message has been received from the preceding/succeeding node, the MSC server releases any MGW allocated resources for the network side. If any resources were seized in the MGW, the MSC server shall use the Release Bearer and Release Termination procedures to indicate to the MGW to remove the network side bearer termination and that the bearer can be released towards the preceding/succeeding MGW. After the resources in the MGW are released the MSC server sends the Release Complete message to the preceding/succeeding node (bullet 1 in figure 7.2).

#### 7.1.2.2 Call clearing to the UE

The MSC server initiates call clearing towards the UE and requests release of the associated radio resources as described in 3GPP TS 23.108[18]. Once the call clearing and the release of the associated radio resources have been completed, the MSC server releases any MGW allocated resources for the access side. If any resources were seized in the MGW, the MSC server uses the Release Termination procedure to requests the MGW to remove the access side bearer termination (bullet 2 or bullet 3 in figure 7.2).

### 7.1.2.3 Example

Figure 7.1 shows the network model for a network initiated clearing of the mobile call. The "squared" line represents the call control signalling. The "dotted" line represents the bearer control signalling (not applicable in A/Gb mode for the A-interface) and the bearer. The MSC server seizes one context with two bearer terminations in the MGW. Bearer termination T1 is used for the bearer towards RNC/BSC and bearer termination T2 is used for the bearer towards succeeding MGW.



**Figure 7.1: Network Initiated Call Clearing (Network model)**

Figure 7.2 shows the message sequence example for the network initiated clearing of a mobile call. In the example the when the call clearing indication is received from the preceding/succeeding node, MSC server indicates that the network bearer can be released and to release the network side bearer termination. A fter the release of the network side bearer termination the MSC server indicates to the preceding/succeeding node that call clearing has been completed. The MSC server initiates call clearing towards the UE and requests release of the radio resource. After the response of the radio resource release is received then the MSC server requests release of the access side bearer termination.

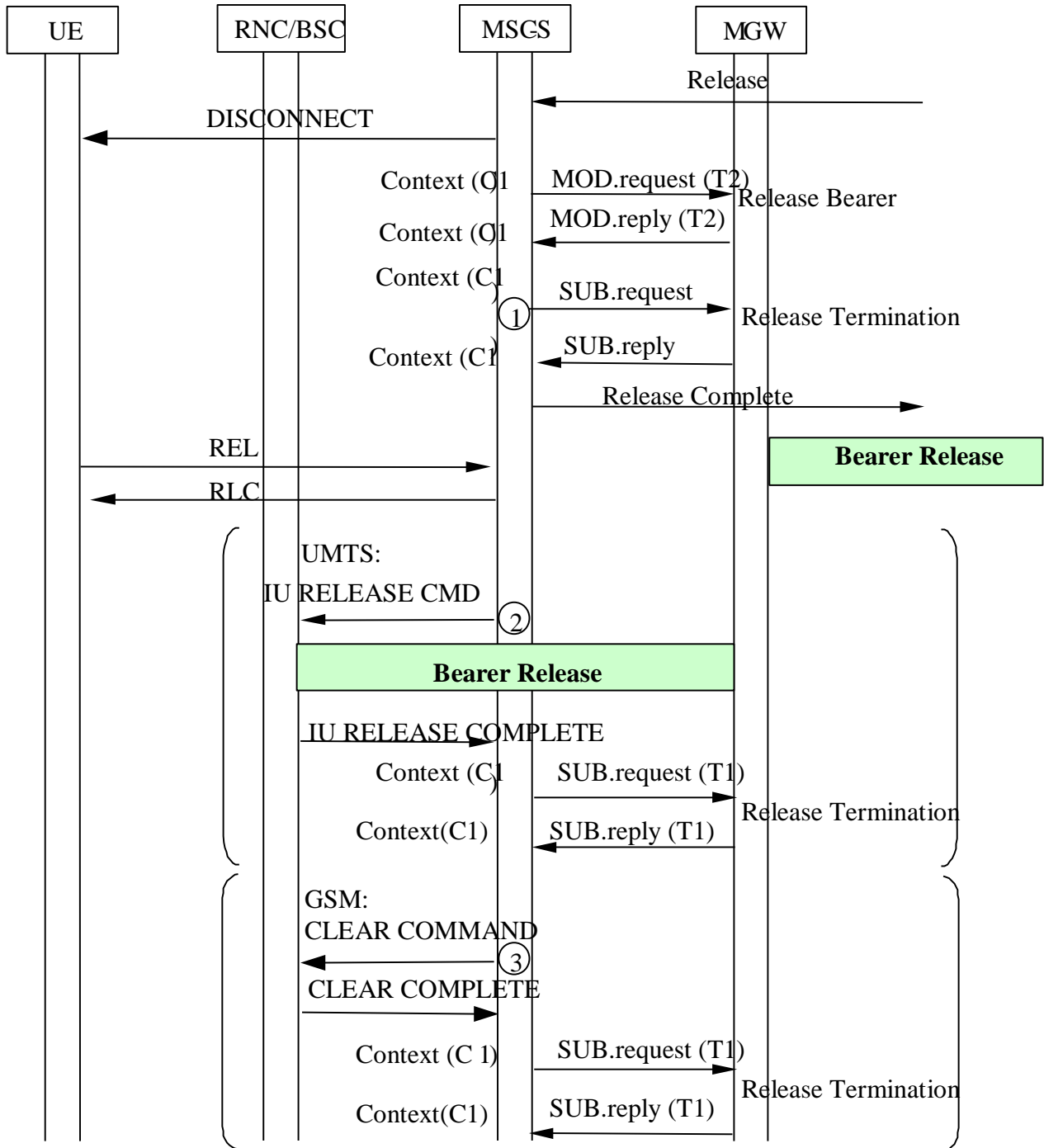


Figure 7.2: Network Initiated Call Clearing (message sequence chart)

## 7.2 User Initiated

The user initiated call clearing shall be performed in accordance with 3GPP TS 23.108 [18]. The following clauses describe the additional requirements for the bearer independent CS core network.

## 7.2.1 Void

## 7.2.2 MSC server

### 7.2.2.1 all clearing from the UE

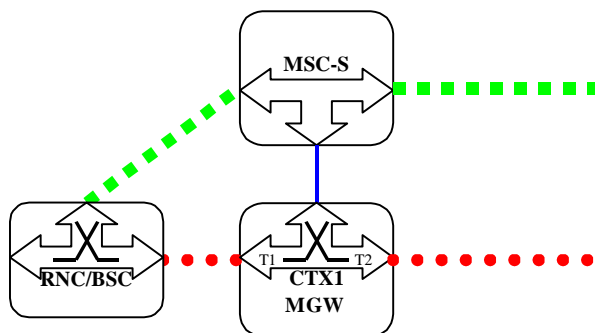
The UE initiated call clearing is performed and the release of the associated radio resources is performed as described in 3GPP TS 23.108 [18]. Once the call clearing and the associated radio resources release have been completed, the MSC server releases any MGW allocated resources for the access side. If any resources were seized in the MGW the MSC server uses the Release Termination procedure to request the MGW to remove the access side bearer termination (bullet 1 or bullet 2 in figure 7.4).

### 7.2.2.2 Call clearing to the network side

The MSC server sends the Release message to the preceding/succeeding node. Once the preceding/succeeding node has sent the Release Complete, the MSC server releases any MGW allocated resources for the network side. If any resources were seized in the MGW server shall use the Release Bearer and Release Termination procedures to indicate to the MGW to remove the network side bearer termination and that the bearer can be released towards the preceding/succeeding MGW (bullet 3 in figure 7.4).

### 7.2.2.3 Example

Figure 7.3 shows the network model for a user initiated clearing of a mobile call. The "squared" line represents the call control signalling. The "dotted" line represents the bearer control signalling (not applicable in A/Gb mode for the A - interface) and the bearer. The MSC server seizes one context with two bearer terminations in the MGW. Bearer termination T1 is used for the bearer towards RNC/BSC and bearer termination T2 is used for the bearer towards succeeding MGW.



**Figure 7.3: User Initiated Call Clearing (Network model)**

Figure 7.4 shows the message sequence example for the user initiated clearing of a mobile call. In the example the UE initiates call clearing towards the MSC server and the MSC server requests release of the radio resource. After the response of the radio resource release is received the MSC server requests the release of the access side bearer termination. The MSC server initiates call clearing towards the preceding/succeeding node. Once the preceding/succeeding node has indicated that call clearing has been completed, the MSC server indicates that the network bearer can be released and to release the network side bearer termination.

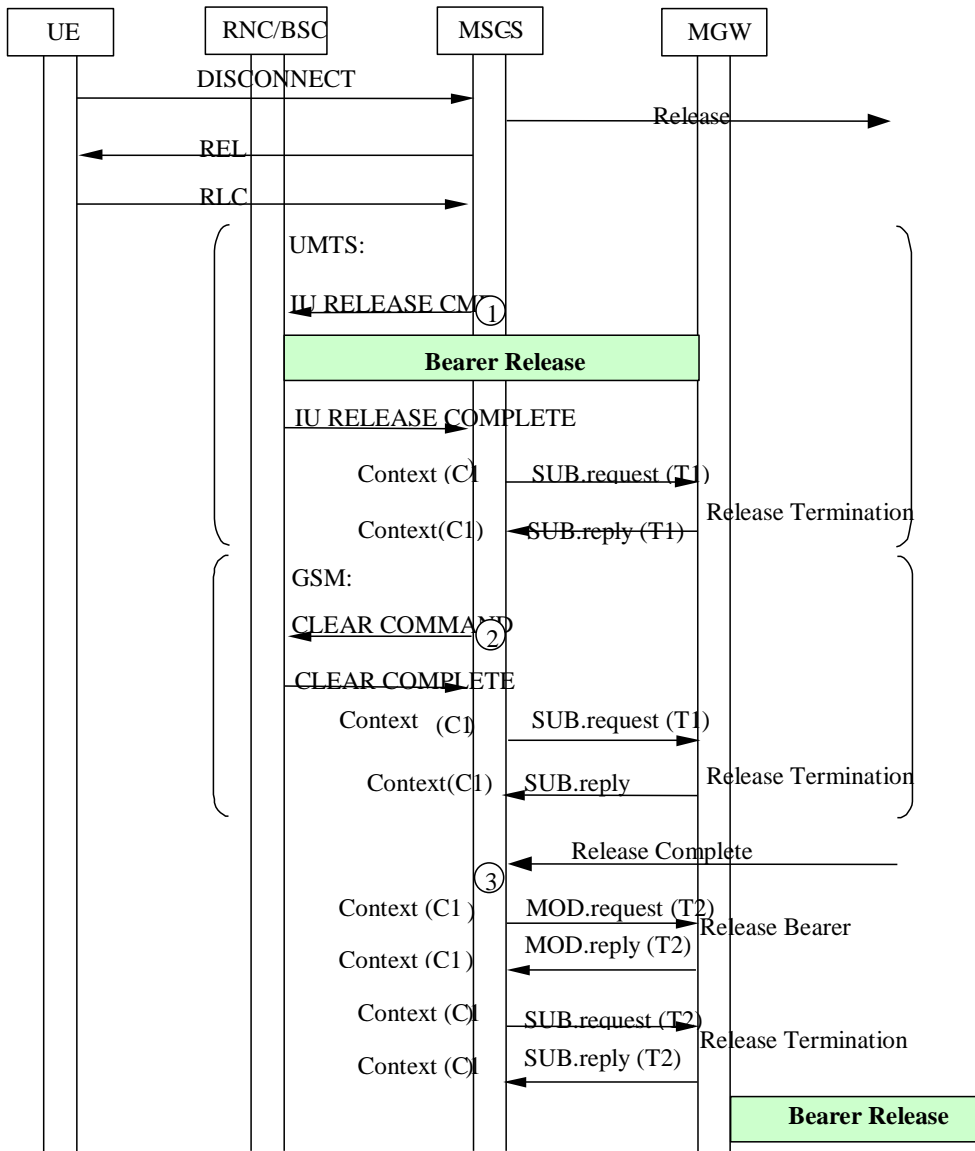


Figure 7.4: User Initiated Call Clearing (message sequence chart)

### 7.3 (G)MSC server Initiated

The following clauses describe the additional requirements for (G)MSC server initiated call clearing in the bearer independent CS core network.

#### 7.3.1 GMSC server

##### 7.3.1.1 Call clearing to the destination side

If the call is already established towards the destination, call clearing is performed as described in clause 7.1.1, call clearing to the outgoing side.

##### 7.3.1.2 Call clearing to the originating side

The call clearing to the originating side is performed as described in clause 7.1.1, call clearing to the outgoing side.



## 7.3.2 MSC server

### 7.3.2.1 Call clearing to the UE

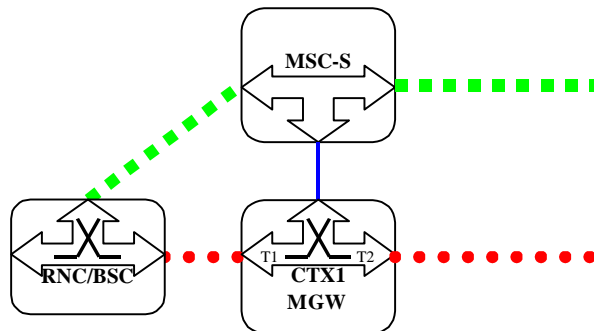
The call clearing to the UE is performed as described in clause 7.1.2, call clearing to the UE (bullet 1 and bullet 2 in figure 7.6).

### 7.3.2.2 Call clearing to the network side

If the call is already established towards the network side, the call clearing to the network side is performed as described in clause 7.2.2, call clearing to the network side (bullet 3 in figure 7.6).

### 7.3.2.3 Example

Figure 7.5 shows the network model for the MSC server initiated clearing of the mobile call. The "squared" line represents the call control signalling. The "dotted" line represents the bearer control signalling (not applicable in A/Gb mode for the A-interface) and the bearer. The MSC server seizes one context with two bearer terminations in the MGW. Bearer termination T1 is used for the bearer towards RNC/BSC and bearer termination T2 is used for the bearer towards succeeding MGW.



**Figure 7.5: MSC Server Initiated Call Clearing (Network model)**

Figure 7.6 shows the message sequence example for the MSC server initiated clearing of a mobile call. In the example the MSC server initiates call clearing of the network side and the access side. After the call clearing towards the UE and the release of the radio resource have been completed the MSC server requests release of the access side bearer termination. Once the preceding/succeeding node has indicated that call clearing has been completed, the MSC server indicates that the network bearer can be released and to release the network side bearer termination.

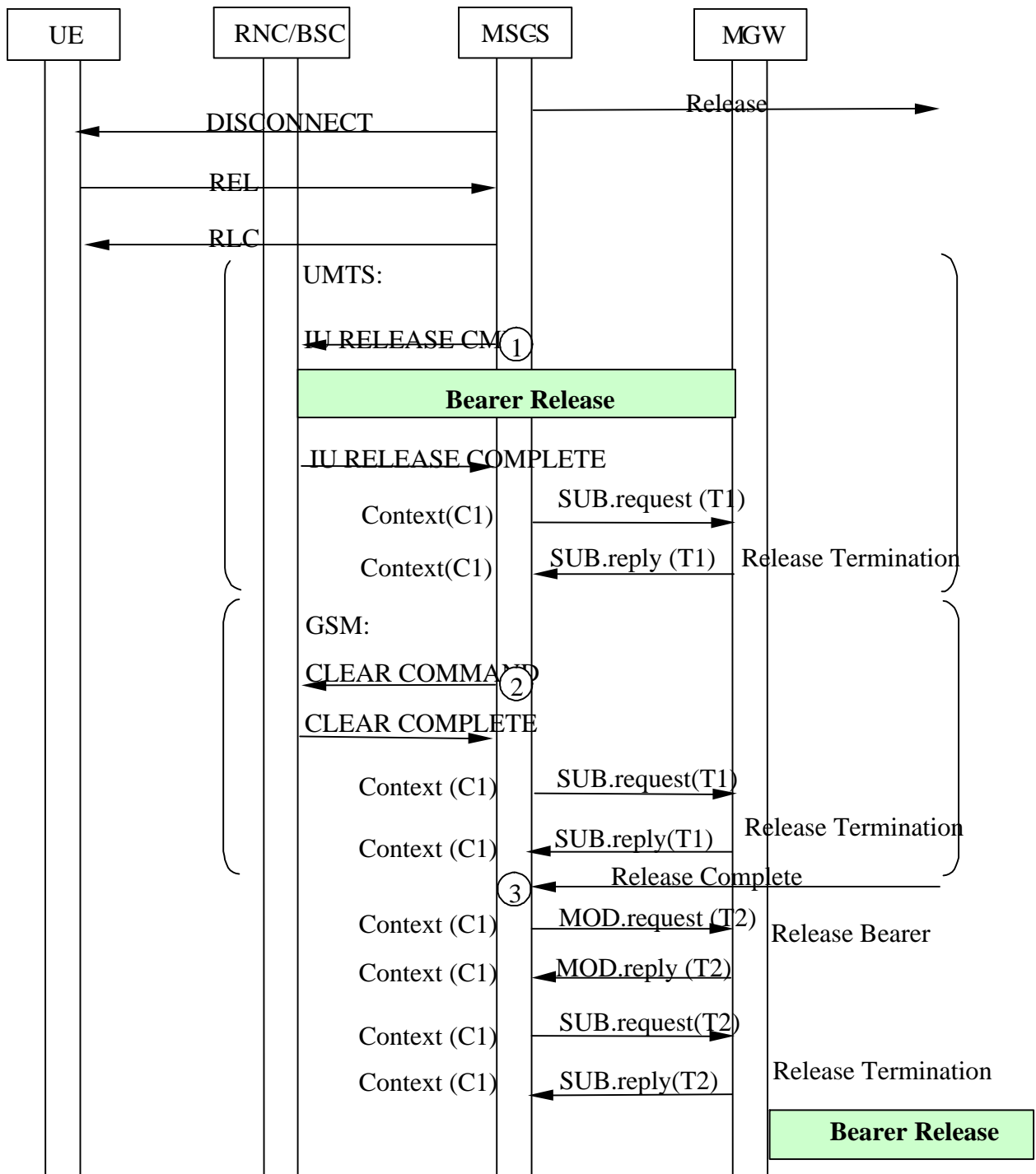


Figure 7.6: MSC Server Initiated Call Clearing (message sequence chart)

## 7.4 MGW Initiated

The following clauses describe the additional requirements for MGW initiated call clearing in the bearer independent CS core network.

### 7.4.1 GMSC server

#### 7.4.1.1 Bearer released on the destination side

After the GMSC server has received the Bearer Released procedure from the MGW, it shall send the Release message to the succeeding node. Once the succeeding node has sent the Release Complete message, the GMSC server releases any MGW allocated resources for the destination side. The GMSC server uses the Release Termination procedure to request the MGW to remove the destination side bearer termination.

The call clearing to the incoming side is performed as described in clause 7.1.1.2, call clearing to the outgoing side.

#### 7.4.1.2 Bearer released on the originating side

After the GMSC server has received the Bearer Released procedure from the MGW, the GMSC server sends the Release message to the preceding node. Once the preceding node has sent the Release Complete message, the GMSC server releases any MGW allocated resources for the originating side. The GMSC server uses the Release Termination procedure to request the MGW to remove the originating side bearer termination.

If the call is already established towards the destination side, call clearing to the destination side is performed as described in clause 7.1.1.2, call clearing to the outgoing side.

### 7.4.2 MSC server

#### 7.4.2.1 Bearer released on the access side

After the MSC server has received the Bearer Released procedure from the MGW, the MSC server initiates the call clearing towards the UE and requests release of the allocated radio resources as described in 3GPP TS 23.108 [18]. Once the call clearing and the radio resources release have been completed, the MSC server releases any MGW allocated resources for the access side. The MSC server uses the Release Termination procedure to request the MGW to remove the access side bearer termination.

If the call is already established towards the network side, call clearing to the network side is performed as described in clause 7.2, call clearing to the network side.

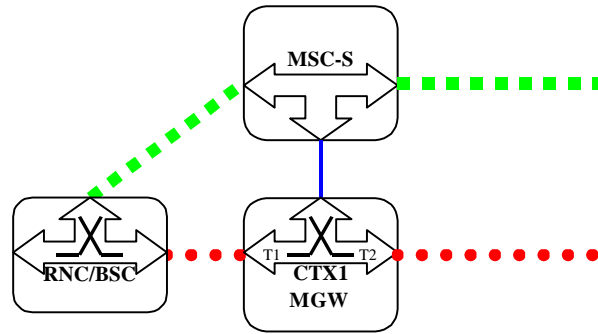
#### 7.4.2.2 Bearer released on the network side

After the MSC server has received the Bearer Released procedure from the MGW, the MSC server sends the Release message to the preceding/succeeding node. Once the preceding/succeeding node has sent the Release Complete message, the MSC server releases any MGW allocated resources for the network side. The MSC server uses the Release Termination procedure to request the MGW to remove the network side bearer termination (bullet 1 and bullet 2 in figure 7.8).

Call clearing to the UE is performed as described in clause 7.1.2.2, call clearing to the UE (bullet 3 in figure 7.8).

#### 7.4.2.3 Example

Figure 7.7 shows the network model for an MGW initiated clearing of a mobile call. The "squared" line represents the call control signalling. The "dotted" line represents the bearer control signalling (not applicable in A/Gb mode for the A-interface) and the bearer. The MSC server seizes one context with two bearer terminations in the MGW. Bearer termination T1 is used for the bearer towards RNC/BSC and bearer termination T2 is used for the bearer towards succeeding MGW.



**Figure 7.7: MGW Initiated Call Clearing (Network model)**

Figure 7.8 shows the message sequence example for the MGW initiated clearing of a mobile call. After the MSC server is notified that the MGW has released the network side bearer, the MSC server initiates call clearing of the network side and the access side. After the call clearing towards the UE and the radio resource release have been completed the MSC server requests release of the access side bearer termination. Once the preceding/succeeding node has indicated that call clearing has been completed, the MSC server requests the release of the network side bearer termination.

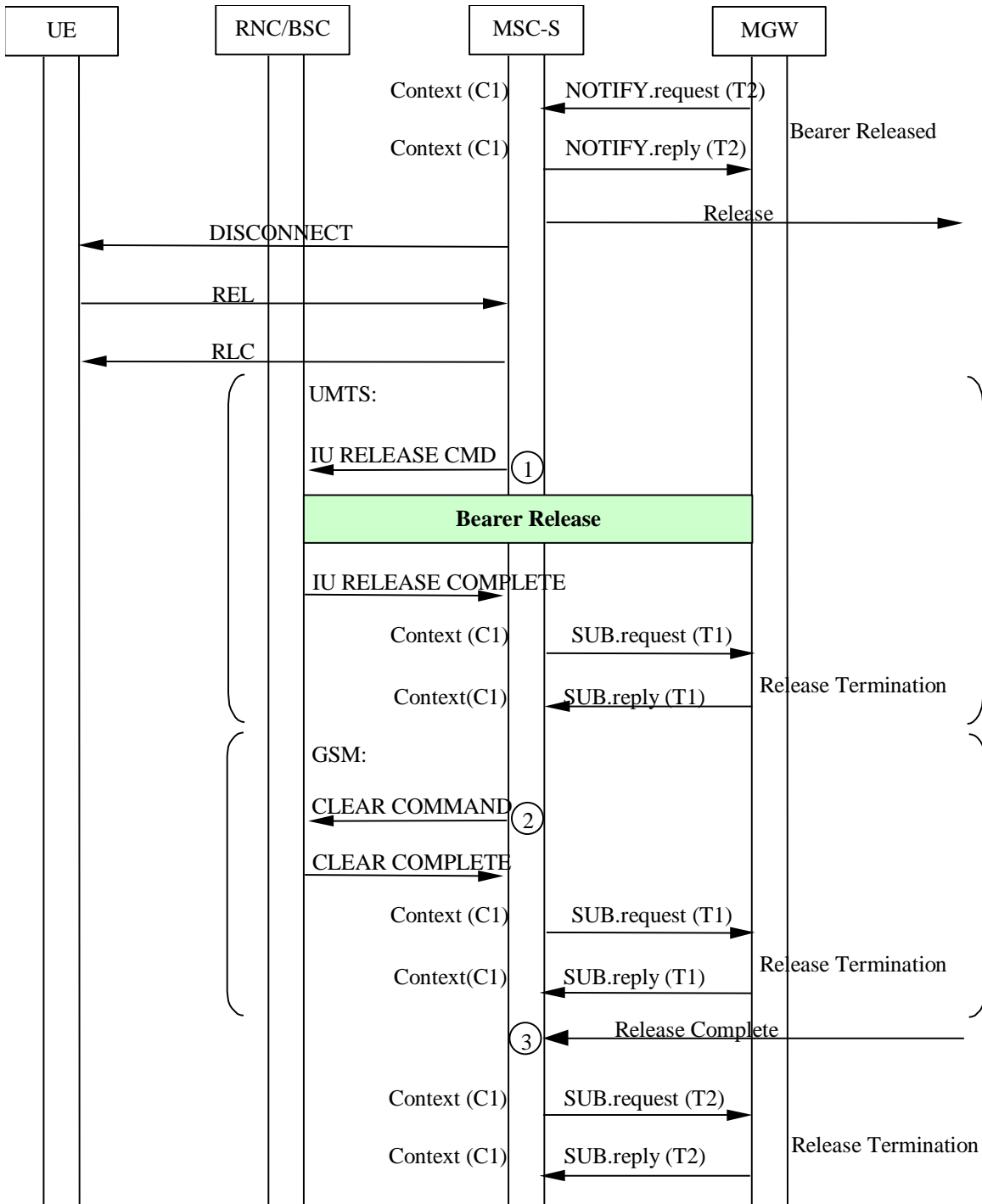


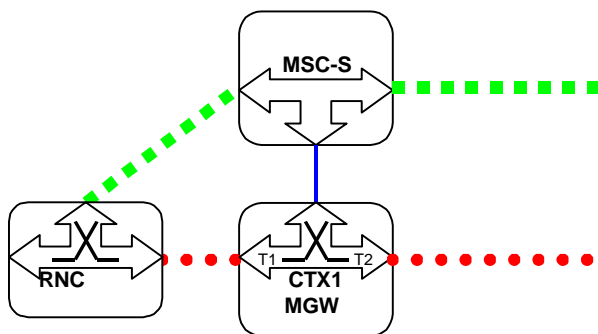
Figure 7.8: MGW Initiated Call Clearing (message sequence chart)

## 7.5 Call Clearing for Iu Interface on IP

Procedures for Call Clearing where the Iu Interface is on IP are as described in sections 7.1 to 7.4, with the exception that only the Access side procedures apply and the Release Bearer procedure is not sent. For Iu Interface on IP, the Release Termination procedures for IP are used to clear the MGW termination from the (G)MSC.

Example

Figure 7.9 shows the network model for a network initiated clearing of the mobile call when IP transport is used on the Iu interface. The 'squared' line represents the call control signalling. The 'dotted' line represents the bearer. The MSC server releases one context with two bearer terminations in the MGW. Bearer termination T1 is used for the bearer towards RNC/BSC and bearer termination T2 is used for the bearer towards succeeding MGW.



**Figure 7.9 Network Initiated Call Clearing (Network model)**

Figure 7.10 shows the message sequence example for the network initiated clearing of a mobile call when IP transport is used on the Iu Interface. In the example when the call clearing indication is received from the preceding/succeeding node, MSC server indicates that network bearer can be released and to release the network side bearer termination. After the release of the network side bearer termination the MSC server indicates to the preceding/succeeding node that call clearing has been completed. The MSC server initiates call clearing towards the UE and requests release of the radio resource. After the response of the radio resource release is received then the MSC server requests release of the access side bearer termination.

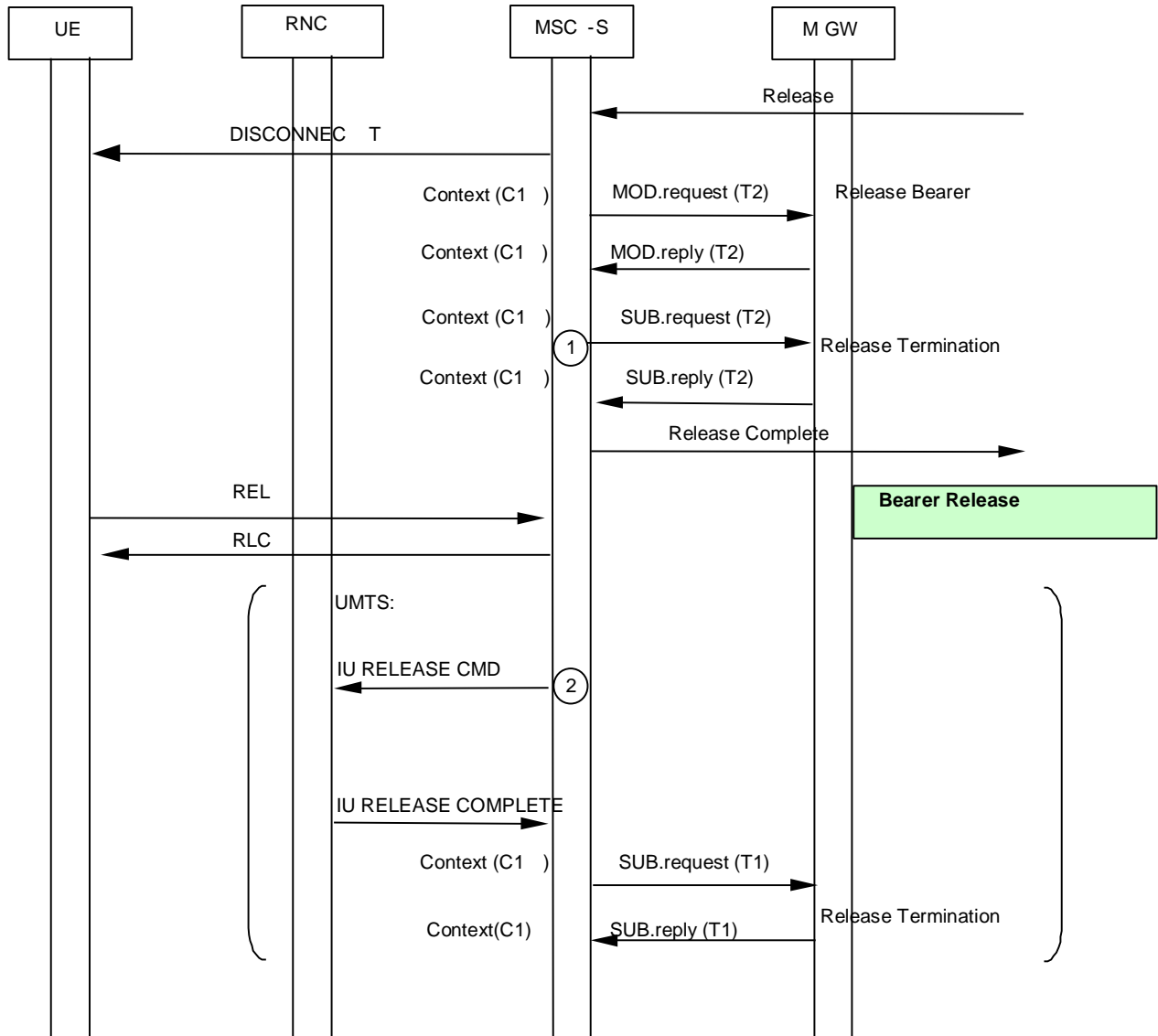


Figure 7.10 Network Initiated Call Clearing (message sequence chart)

## 8 Handover/Relocation

NOTE: All message sequence charts in this clause are examples. All valid handover/relocation message sequences can be derived from the example message sequences and associated message pre-conditions.

### 8.1 UMTS to UMTS

In the context of the following clauses, the terms RNS or RNC refer also to a GERAN BSS or BSC (respectively) when serving an UE in Iu mode.

#### 8.1.1 Intra-MSRNS/SBSS Relocation

The procedures specified in 3GPP TS 23.009 [8] for "Intra-3G\_MSRNS Relocation" shall be followed. The following clauses describe the additional requirements for the bearer independent CS core network.

### 8.1.1.1 Relocation Required

When the Relocation Required message is received, the MSC server requests the MGW to provide a binding reference and a bearer address, using the Prepare Bearer procedure. For speech calls, the MSC server shall provide the MGW with the speech coding information for the bearer. For non-speech calls the MSC server also provides the MGW with the same PLMN Bearer Capability [4] as was provided at the last access bearer assignment. The MSC server uses the Change Flow Direction Procedure to request the MGW to set the Handover Device to initial state. The MSC server sends the Relocation Request message, containing the bearer address and the binding reference, to RNC-B (bullet 1 in figure 8.2/1).

For Relocation towards GERAN Iu mode the GERAN capabilities of the target cell will be indicated to the MSC-Server within the RANAP RELOCATION REQUIRED message if the target cell provides different capabilities than the current cell. If no information about the GERAN capabilities of the target cell are received within this message, the MSC-Server shall assume that the GERAN target cell will provide the same capabilities as the current cell (for details see [29]). The MSC server shall indicate to GERAN the selected services within the RANAP RELOCATION REQUEST message. The MSC server shall not set codec information in the NAS Synchronisation Indicator (see [4]). Instead it shall set codec information in the GERAN BSC container.

### 8.1.1.2 Relocation Command/Relocation Detect

When the MSC server sends the Relocation Command message or alternatively if it receives the Relocation Detect message, the MSC server uses the Change Flow Direction procedure to request the MGW to set the Handover Device to intermediate state (bullet 2 in figure 8.2/1).

### 8.1.1.3 Relocation Complete

When the MSC server receives the Relocation Complete message, it requests RNC-A to release the IU. The MSC server also requests the MGW to set the Handover Device to its final state by removing the bearer termination towards RNC-A, using the Release Termination procedure (bullet 3 in figure 8.2/2).

### 8.1.1.4 Interworking function

The interworking function used by the MGW before relocation will also be used after relocation.

### 8.1.1.5 Codec handling

The MGW may include a speech transcoder based upon the speech coding information provided to each bearer termination.

### 8.1.1.6 Voice Processing function

After relocation, the MGW may continue or modify voice-processing function(s) provided to each bearer termination.

### 8.1.1.7 Handling of multiple bearers (multicall)

If the UE is engaged with multiple bearers all procedures related to the handling of bearers and terminations described for the relocation of a single bearer shall be repeated for each bearer.

### 8.1.1.8 Failure Handling in MSC server

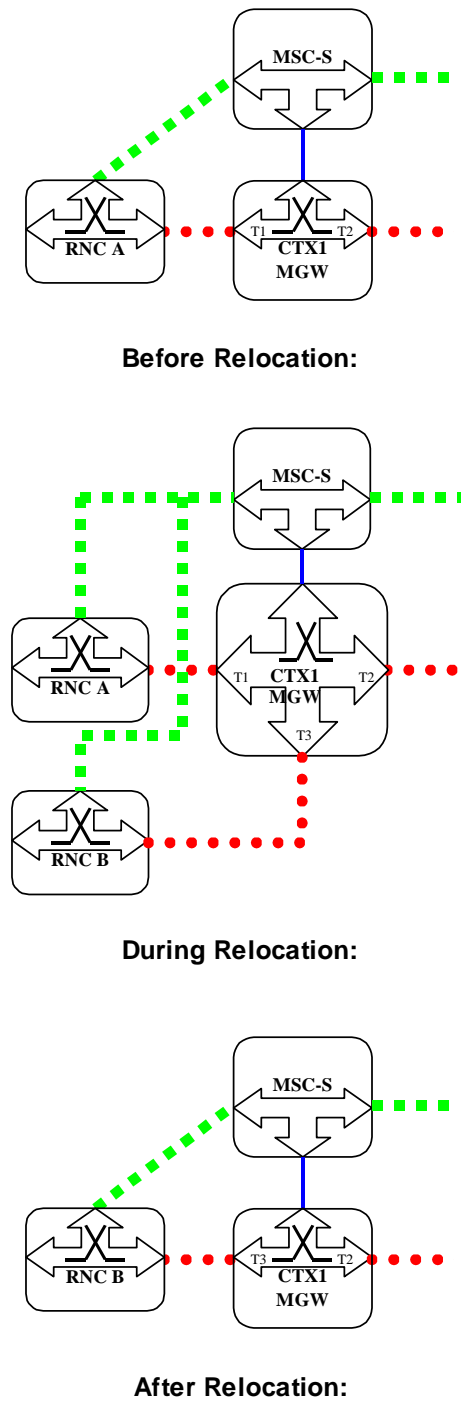
When a procedure between the MSC server and the MGW fails the MSC server shall handle the failure as an internal error in accordance with 3GPP TS 23.009 [8] and 3GPP TS 29.010 [23]. If MGW resources have been already seized at the target access side then the resources shall be released using the Release Termination procedure. If the call is to be cleared, then it shall be handled as described in clause 7.3.

### 8.1.1.9 Example

Figure 8.1 shows the network model for the Intra-MSC SRNS Relocation. The "squared" line represents the call control signalling. The "dotted" line represents the bearer control signalling and the bearer. The bearer termination T1 is used



for the bearer towards RNC-A, bearer termination T3 is used for the bearer towards RNC-B and the bearer termination T2 is used for the bearer towards the succeeding/preceding MGW.



**Figure 8.1: Intra-MSC SRNS Relocation (network model)**

Figure 8.2 shows the message sequence example for the Intra-MSC SRNS Relocation. It is assumed that the Handover Device is located in the MGW, which has been selected for the call establishment by the MSC server. The MSC server controls the call and the mobility management. It is also assumed that only one bearer has been established towards RNC-A. In the example the MSC server requests seizure of RNC-B side bearer termination with specific flow directions. The MSC server orders the establishment of the bearer by sending Relocation Request towards RNC-B. When the relocation is detected in RNC-B the MSC server requests to change the flow directions between the terminations within the context. When the MSC server receives a Relocation Complete indication from RNC-B it orders RNC-A to release the

IU. This action causes release of the bearer between the RNC and the MGW. Finally the MSC server requests the MGW to release RNC-A side bearer termination.

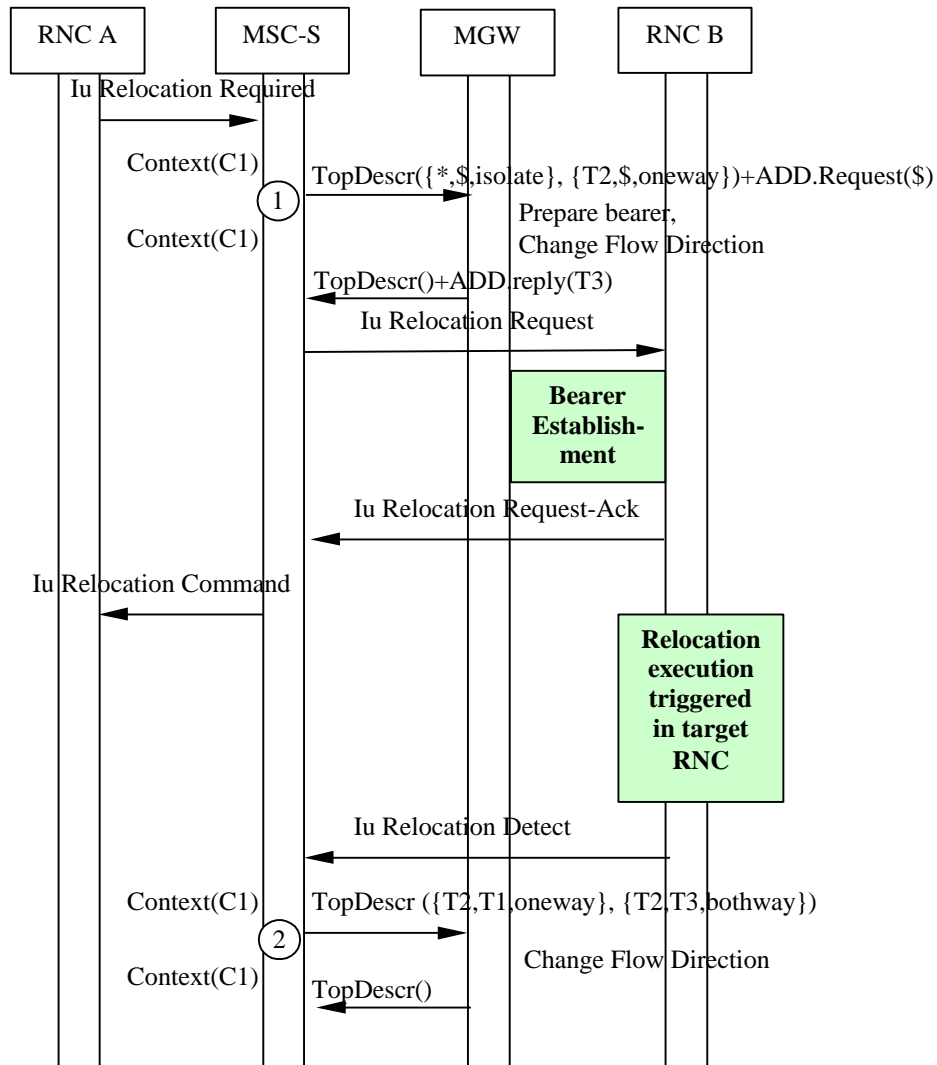


Figure 8.2/1: Intra-MSR SRNS Relocation (message sequence chart)

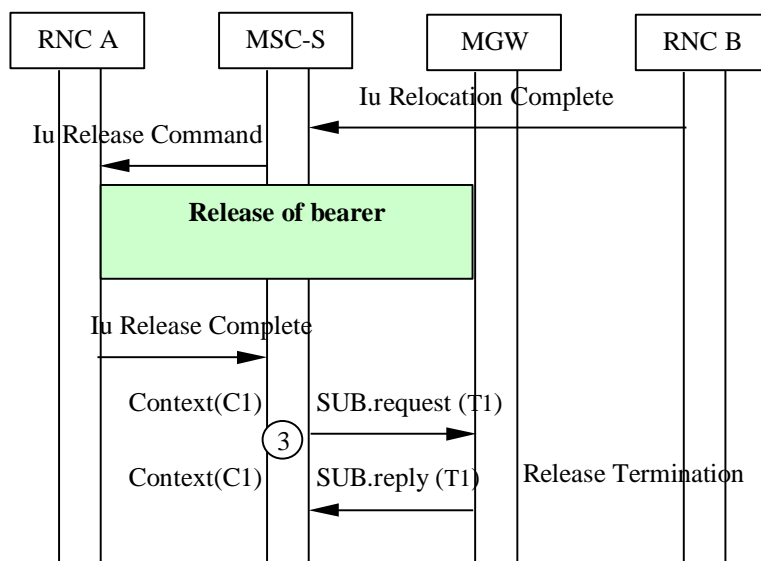


Figure 8.2/2: Intra-MSR SRNS Relocation (message sequence chart)

## 8.1.2 Basic Inter-MSC SRNS/SBSS Relocation

The procedures specified in 3GPP TS 23.009 [8] for "Basic Relocation Procedure Requiring a Circuit Connection between 3G\_MSC-A and 3G\_MSC-B" shall be followed. The following clauses describe the additional requirements for the bearer independent CS core network.

### 8.1.2.1 MSC-A/MGW-A

#### 8.1.2.1.1 Relocation Required

For Relocation towards GERAN Iu mode the GERAN capabilities of the target cell will be indicated to the MSC-A server within the RANAP RELOCATION REQUIRED message if the target cell provides different capabilities than the current cell. If no information about the GERAN capabilities of the target cell are received within this message, the MSC-A server shall assume that the GERAN target cell will provide the same capabilities as the current cell (for details see [29]).

The MSC-A server shall indicate to the MSC-B server the GERAN capabilities of the target cell, if available, with the MAP Prepare Handover request. For speech calls, the MSC-A server shall additionally indicate to the MSC-B server the selected codec, the list of supported codecs, and the currently used codec.

Furthermore, the MSC-A server shall indicate to the GERAN the selected service within the RANAP RELOCATION REQUEST message and shall set the RAB parameters within the RANAP RELOCATION REQUEST message according to the selected service. The MSC server shall not set codec information in the NAS Synchronisation Indicator (see [4]). Instead it shall set codec information in the GERAN BSC container..

#### 8.1.2.1.2 Bearer establishment between MGW-A and MGW-B

The handling of the bearer establishment is as described for a Basic Mobile Originating Call, using either forward or backward bearer establishment. For speech calls, the MSC-A server shall provide the MGW-A with the speech coding information for the bearer. For non-speech calls, the MSC-A server shall provide MGW-A with the same PLMN Bearer Capability [4] as was provided at the last access bearer assignment. The MSC-A server also uses the Change Flow Direction procedure to request MGW-A to set the Handover Device to initial state (bullet 3 in figure 8.4/1).

#### 8.1.2.1.3 Relocation Command/Relocation Detect

When the MSC-A server sends the Relocation Command message or alternatively if it receives the Relocation Detect message, the MSC-A server uses the Change Flow Direction procedure to request MGW-A to set the Handover Device to intermediate state (bullet 4 in figure 8.4/2).

#### 8.1.2.1.4 Relocation Complete

When the MSC-A server receives the Relocation Complete message, it requests RNC-A to release the IU. The MSC-A server also requests MGW-A to set the Handover Device to its final state by removing the bearer termination towards RNC-A, using the Release Termination procedure (bullet 5 in figure 8.4/2).

#### 8.1.2.1.5 Interworking function

The interworking function used by MGW-A before relocation will also be used after relocation.

#### 8.1.2.1.6 Codec handling

The MGW may include a speech transcoder based upon the speech coding information provided to each bearer termination.

#### 8.1.2.1.7 Voice Processing function

Voice processing function(s) provided by MGW-A before relocation, may be modified or disabled by MGW-A after relocation.

#### 8.1.2.1.8 Handling of multiple bearers (multicall)

If the UE is engaged with multiple bearers all procedures related to the handling of bearers and terminations described for the relocation of a single bearer shall be repeated for each bearer.

#### 8.1.2.1.9 Failure Handling in MSC server

When a procedure between the MSC-A server and MGW-A fails the MSC-A server shall handle the failure as an internal error in accordance with 3GPP TS 23.009 [8] and 3GPP TS 29.010 [23]. If call establishment towards MSC-B has already started then the call towards MSC-B server shall be cleared as described in clause 7.3. If the original call is to be cleared, then it shall be handled as described in clause 7.3.

### 8.1.2.2 MSC-B/MGW-B

#### 8.1.2.2.1 MGW selection

The MSC-B server selects an MGW when it receives Prepare Handover Request message (bullet 1 in figure 8.4/1).

#### 8.1.2.2.2 Bearer establishment towards RNC-B

When the MSC-B server has selected MGW-B it requests MGW-B to provide a binding reference and a bearer address, using the Prepare Bearer procedure. For speech calls, the MSC-B server shall provide the MGW-B with the speech coding information for the bearer. The MSC-B server sends the Relocation Request message to the RNC-B containing the bearer addresses and binding references (bullet 2 in figure 8.4/1).

For Relocation towards GERAN Iu mode, if the selected service is speech and the MSC-B server cannot provide the codec requested by the MSC-A server, the MSC-B server shall select another codec according to the received GERAN capabilities of the target cell and the received list of supported codecs, and shall set the RAB parameters within the RANAP RELOCATION REQUEST message according to the new selected codec. Furthermore, the MSC-B server shall report the chosen codec and codec modes back to the MSC-A server with MAP Prepare Handover response.

#### 8.1.2.2.3 Bearer establishment between MGW-A and MGW-B

The handling of the bearer establishment is as described at Basic Mobile Terminating Call, using either forward or backward bearer establishment.

#### 8.1.2.2.4 Codec handling

The MGW may include a speech transcoder based upon the speech coding information provided to each bearer termination.

#### 8.1.2.2.5 Voice Processing function

Voice processing function(s) provided by MGW-A before relocation, may be continued or modified by MGW-B after relocation.

#### 8.1.2.2.6 Handling of multiple bearers (multicall)

If the UE is engaged with multiple bearers all procedures related to the handling of bearers and terminations described for the relocation of a single bearer shall be repeated for each bearer.

#### 8.1.2.2.7 Failure Handling in MSC server

When a procedure between the MSC-B server and MGW-B fails the MSC-B server shall handle the failure as an internal error in accordance with 3GPP TS 23.009 [8] and 3GPP TS 29.010 [23]. If MGW-B resources have been already seized at the target access side then the resources shall be released using the Release Termination procedure. The call from MSC-A server shall be released as described at clause 7.1.

8.1.2.2.8 Example

Figure 8.3 shows the network model for the Basic Inter-MSC SRNS Relocation. The "squared" line represents the call control signalling. The "dotted" line represents the bearer control signalling and the bearer. In MGW -A the bearer termination T1 is used for the bearer towards RNC-A, bearer termination T3 is used for the bearer towards MGW-B, and the bearer termination T2 is used for the bearer towards the succeeding/preceding MGW. In MGW -B the bearer termination T4 is used for the bearer towards RNC-B, bearer termination T5 is used for the bearer towards MGW -A.

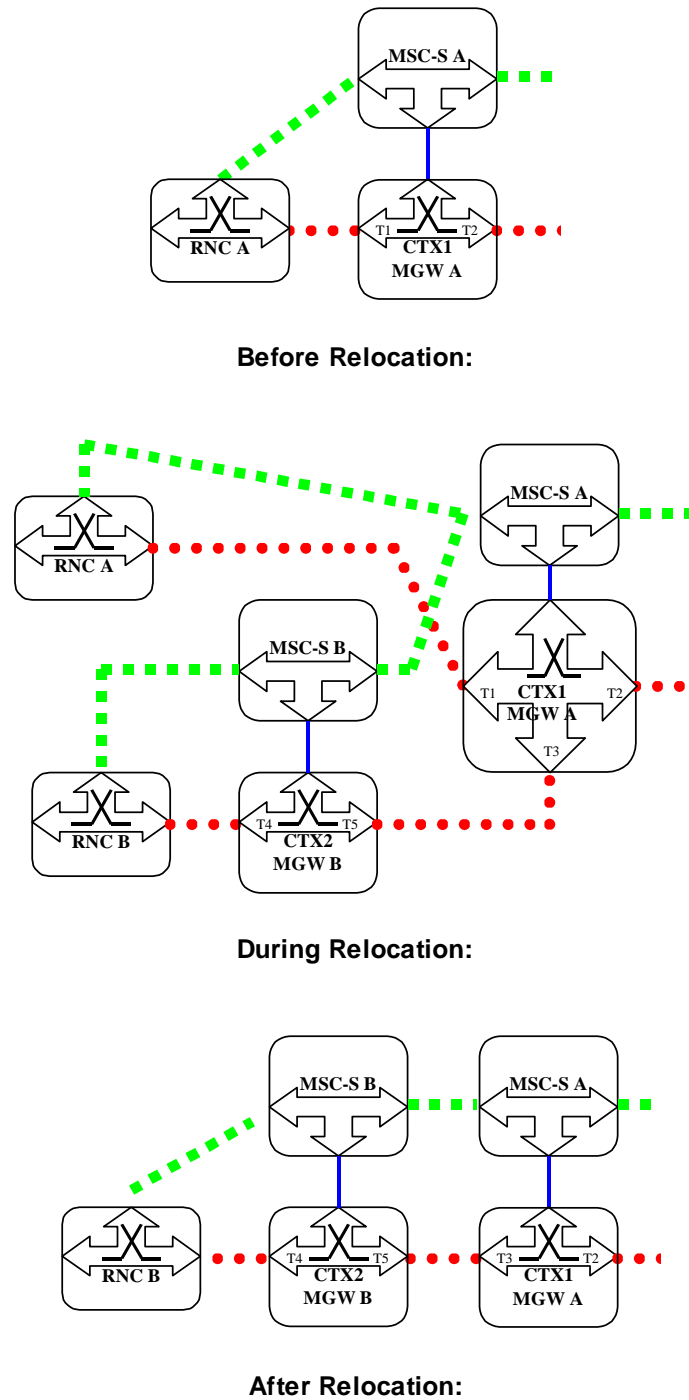


Figure 8.3: Basic Inter-MSC SRNS Relocation (network model)

Figure 8.4 shows the message sequence example for the Basic Inter-MSC SRNS Relocation. It is assumed that the Handover Device is located in the MGW (MGW -A) selected for the call establishment by the MSC server (MSC-A server) which controls the call and the mobility management. It is also assumed that only one bearer has been established towards RNC-A. In the example the MSC-B server requests MGW-B to seize an RNC-B side bearer. The MSC-B server orders the establishment of the bearer towards RNC-B by sending Relocation Request. The call is established between MSC-A and MSC-B servers, and the bearer is established between MGW-A and MGW-B. When the relocation is detected in RNC-B the MSC-A server requests to change the flow directions between the terminations within the context in MGW-A. When MSC-A server receives Relocation Complete indication from MSC-B server it orders RNC-A to release the IU. This action causes release of the bearer between RNC-A and MGW-A. Finally MSC-A server requests MGW-A to remove RNC-A side bearer termination.

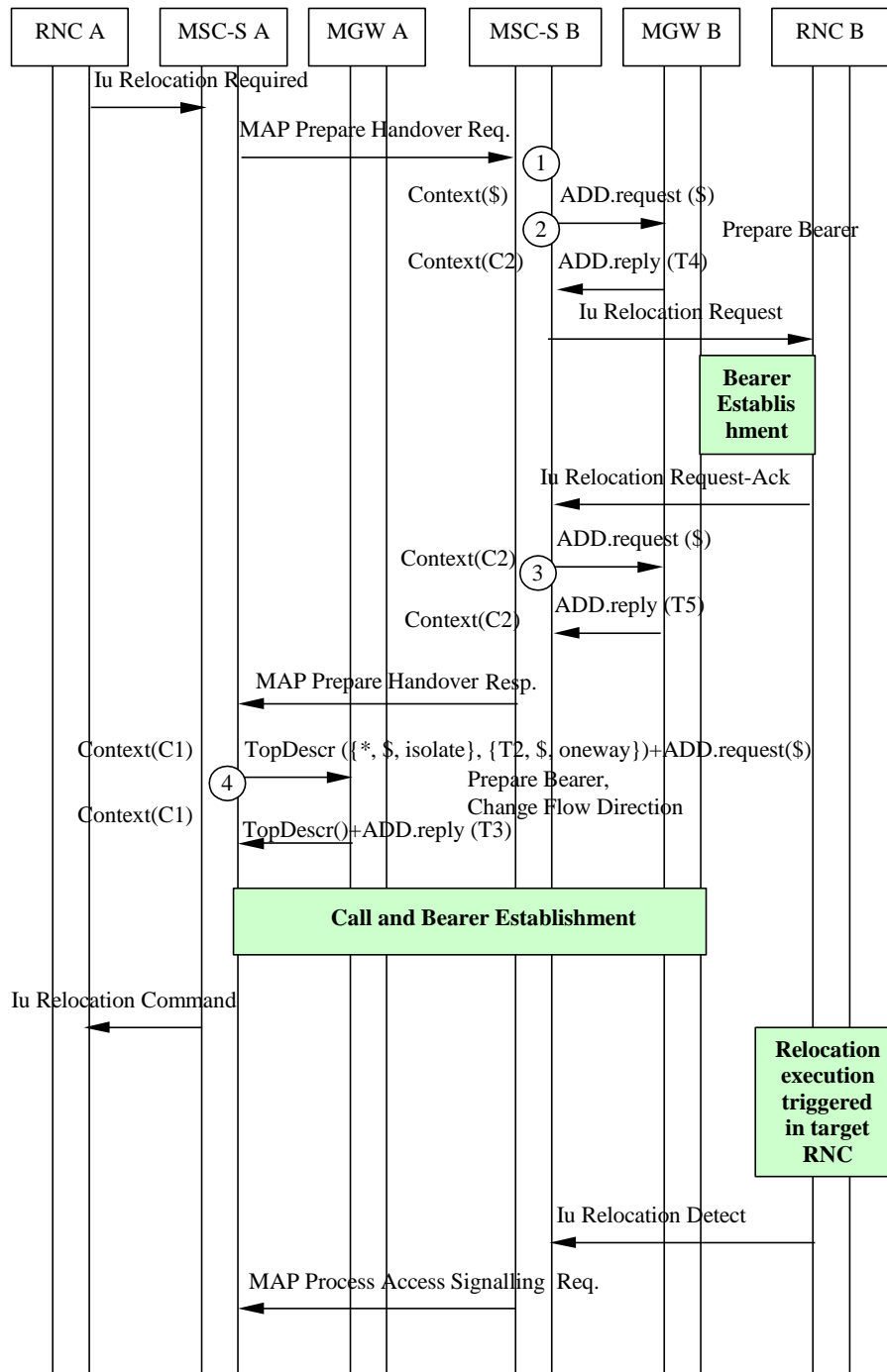


Figure 8.4/1: Basic Inter-MSC SRNS Relocation (message sequence chart)

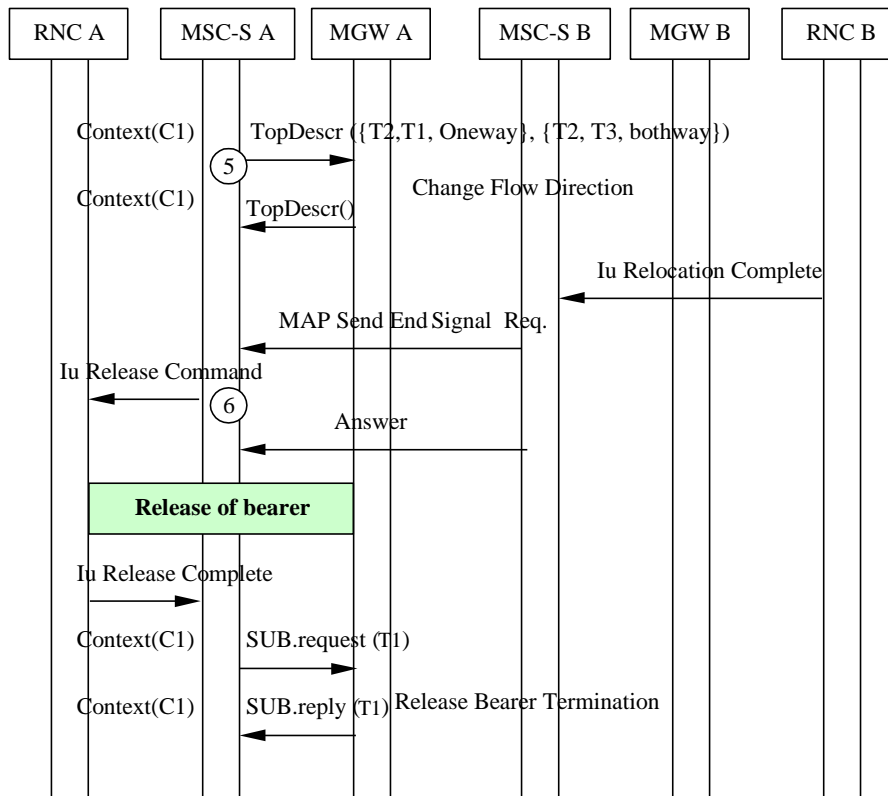


Figure 8.4/2: Basic Inter-MSC SRNS Relocation (message sequence chart)

### 8.1.3 Subsequent Inter-MSC SRNS/SBSS Relocation back to the Anchor MSC

The procedures specified in 3GPP TS 23.009 [8] for "Subsequent Relocation from 3G\_MSC-B to 3G\_MSC-A requiring a Circuit Connection between 3G\_MSC-A and 3G\_MSC-B" shall be followed. The following clauses describe the additional requirements for the bearer independent CS core network.

#### 8.1.3.1 MSC-A/MGW-A

##### 8.1.3.1.1 Relocation Request

When the MSC-A server receives the MAP Prepare Subsequent Handover request containing a Relocation Request message, it requests MGW-A to provide a binding reference and a bearer address using the Prepare Bearer procedure. For speech calls, the MSC-A server shall provide the MGW-A with the speech coding information for the bearer. For non-speech calls the MSC-A server shall provide MGW-A with the same PLMN Bearer Capability [4] as was provided at the last access bearer assignment. The MSC-A server uses the Change Flow Direction procedure to request the MGW-A to set the Handover Device to initial state. The MSC-A server sends the Relocation Request message, containing the bearer address and the binding reference, to RNC-B (bullet 1 in figure 8.6/1).

For Relocation towards GERAN Iu mode, if the selected service is speech and the MSC-A server cannot provide the codec requested by the MSC-B server, the MSC-A server shall select another codec according to the received GERAN capabilities of the target cell and the list of supported codecs.

##### 8.1.3.1.2 Relocation Command/Relocation Detect

When the MSC-A server sends the MAP Prepare Subsequent Handover response message or alternatively if it receives the Relocation Detect message, the MSC-A server uses the Change Flow Direction procedure to requests MGW-A to set the Handover Device to intermediate state (bullet 2 in figure 8.6/1).

### 8.1.3.1.3 Relocation Complete

When the MSC-A server receives the Relocation Complete message, it informs the MSC-B server about reception of this message. The MSC-A server then initiates call clearing towards the MSC-B server as described in clause 7.3.

### 8.1.3.1.4 Interworking function

The interworking function used by MGW-A before relocation will also be used after relocation.

### 8.1.3.1.5 Codec handling

The MGW may include a speech transcoder based upon the speech coding information provided to each bearer termination.

### 8.1.3.1.6 Voice Processing function

Voice processing function(s) provided by MGW-A and MGW-B before relocation, may be continued or modified by MGW-A after relocation.

### 8.1.3.1.7 Handling of multiple bearers (multicall)

If the UE is engaged with multiple bearers all procedures related to the handling of bearers and terminations described for the relocation of a single bearer shall be repeated for each bearer.

### 8.1.3.1.8 Failure Handling in MSC server

When a procedure between the MSC-A server and the MGW fails the MSC-A server shall handle the failure as an internal error in accordance with 3GPP TS 23.009 [8] and 3GPP TS 29.010 [23]. If MGW resources have already been seized at the target access side then the resources shall be released using the Release Termination procedure. If the call is to be cleared, then it shall be handled as described in clause 7.3.

## 8.1.3.2 MSC-B/MGW-B

### 8.1.3.2.1 Relocation Required

For Relocation towards GERAN Iu mode the GERAN capabilities of the target cell will be indicated to the MSC-B server within the RANAP RELOCATION REQUIRED message if the target cell provides different capabilities than the current cell. If no information about the GERAN capabilities of the target cell are received within this message, the MSC-B server shall assume that the GERAN target cell will provide the same capabilities as the current cell (for details see [29]). The different interworking scenarios (e.g. interworking to pre-Rel5 UTRAN) are described in [29].

The MSC-B server shall indicate to the MSC-A server the GERAN capabilities of the target cell, if available, with the MAP Prepare Subsequent Handover request. For speech calls, the MSC-B server shall additionally indicate to the MSC-A server the selected codec and the currently used codec.

Furthermore, the MSC-B server shall indicate to the GERAN the selected service within the RANAP RELOCATION REQUEST message and shall set the RAB parameters within the RANAP RELOCATION REQUEST message according to the selected service. The MSC server shall not set codec information in the NAS Synchronisation Indicator (see [4]). Instead it shall set codec information in the GERAN BSC container..

### 8.1.3.2.2 Relocation Complete

When the MSC-B server receives the Relocation Complete message, it requests RNC-A to release the IU. The MSC-B server requests MGW-B to remove the bearer termination towards RNC-A using the Release Termination procedure (bullet 3 in figure 8.6/2).

### 8.1.3.2.3 Release of bearer towards MGW-A

When the MSC-B server receives a call clearing indication from the MSC-A server, the MSC-B server handles it as described in clause 7.2.



8.1.3.2.4 Handling of multiple bearers (multicall)

If the UE is engaged with multiple bearers all procedures related to the handling of bearers and terminations described for the relocation of a single bearer shall be repeated for each bearer.

8.1.3.2.5 Example

Figure 8.5 shows the network model for the Subsequent Inter-MSC SRNS Relocation back to the Anchor MSC. The "squared" line represents the call control signalling. The "dotted" line represents the bearer control signalling and the bearer. In MGW-A the bearer termination T6 is used for the bearer towards RNC-B, bearer termination T3 is used for the bearer towards MGW-B, and the bearer termination T2 is used for the bearer towards the succeeding/preceding MGW. In MGW-B the bearer termination T4 is used for the bearer towards RNC-A, bearer termination T5 is used for the bearer towards MGW-A.

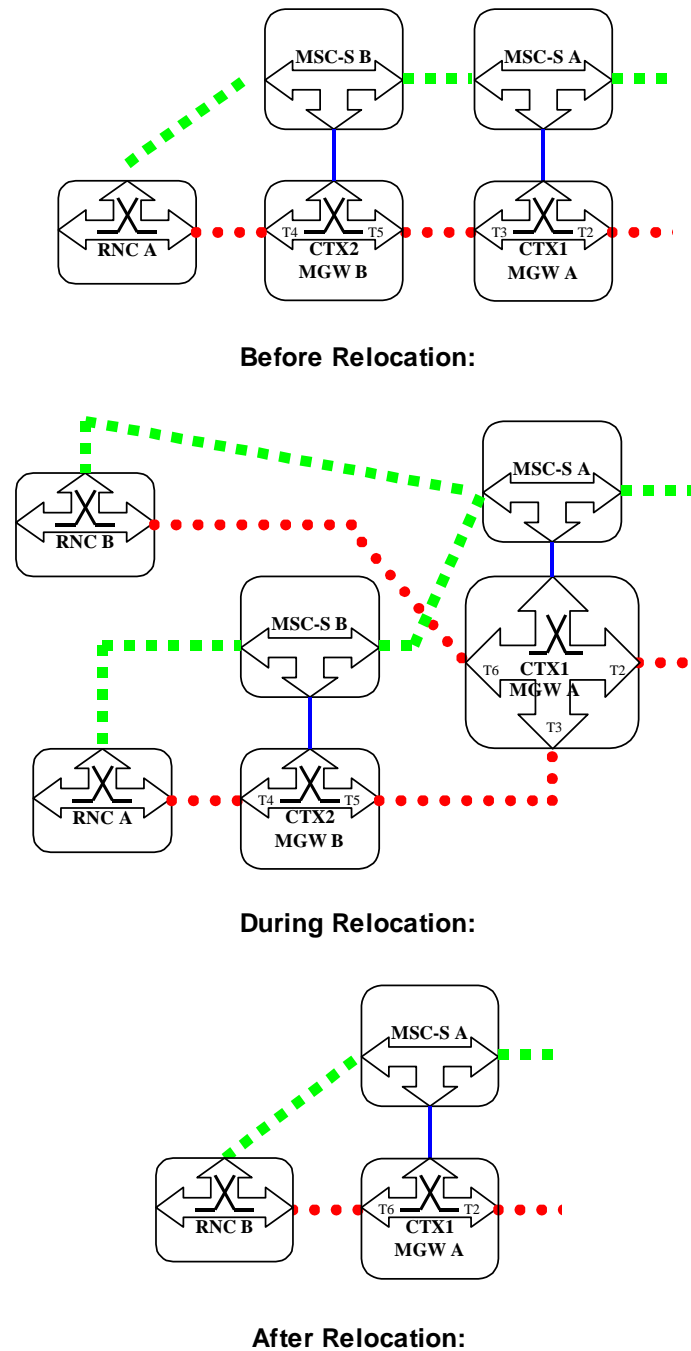


Figure 8.5: Subsequent Inter-MSC SRNS Relocation back to the Anchor MSC (network model)

Figure 8.6 shows the message sequence example for the Subsequent Inter-MSC SRNS Relocation back to the Anchor MSC. It is assumed that the Handover Device is located in the MGW (MGW -A) selected for the call establishment by the MSC server (MSC-A server) which controls the call and the mobility management. Also assumed that only one bearer has been established towards RNC-A. In the example the MSC-A server requests MGW-A to seize RNC-B side bearer termination with specific flow directions. The MSC server orders the establishment of the bearer towards RNC-B by sending Relocation Request. When the relocation is detected in RNC-B the MSC-A server requests to change the flow directions between the terminations within the context in MGW-A. When the MSC-A server receives a Relocation Complete indication from RNC-B it transfers this indication to MSC-B server. MSC-B server orders RNC-A to release the IU. This action causes release of the bearer between RNC-A and the MGW-B. MSC-A server initiates call clearing towards MSC-B server.

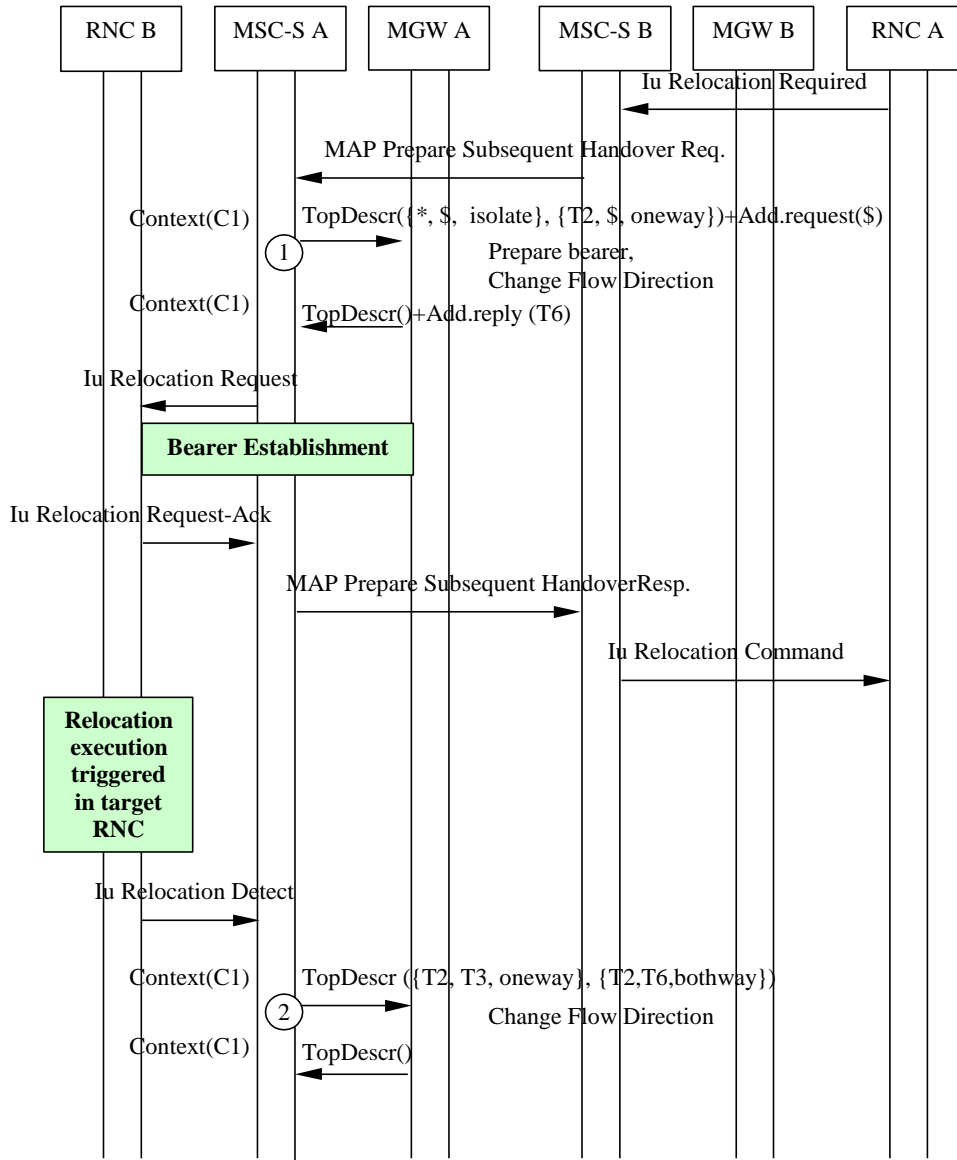
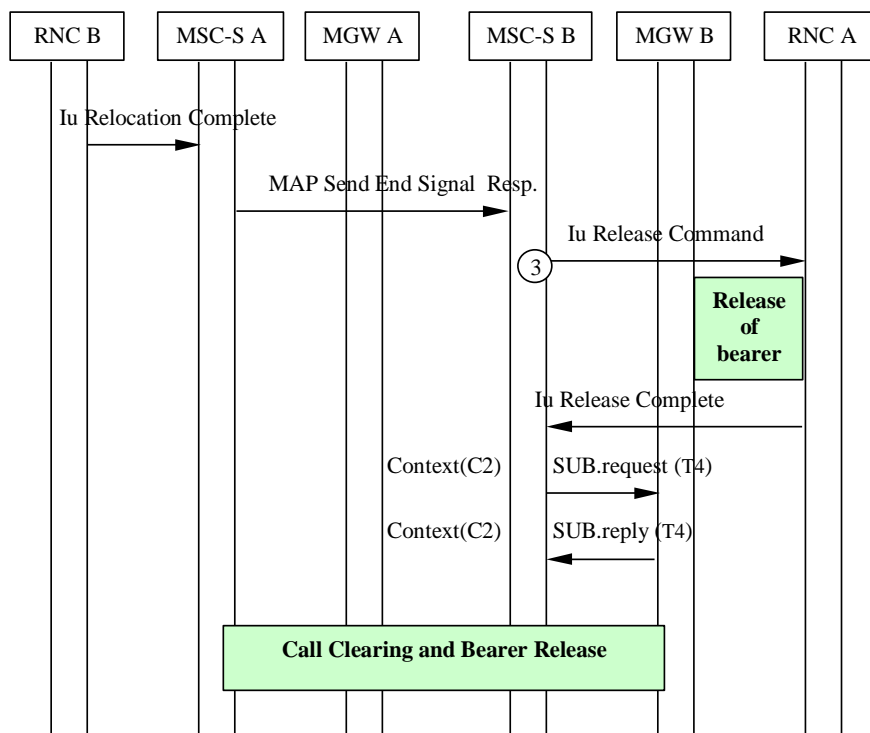


Figure 8.6/1: Subsequent Inter-MSC SRNS Relocation back to the Anchor MSC (message sequence chart)



**Figure 8.6/2: Subsequent Inter-MSC SRNS Relocation back to the Anchor MSC (message sequence chart)**

### 8.1.4 Subsequent Inter-MSC SRNS/SBSS Relocation to a third MSC

The relocation to a third MSC server (from MSC-B server to MSC-B server) is the combination of the two previous inter-MSC handover cases:

- for MSC-B server a subsequent relocation from MSC-B server back to MSC-A server as described in clause 8.1.3; and
- for MSC-B server a basic relocation from MSC-A server to MSC-B server as described in clause 8.1.2.

MSC-A server implements the corresponding parts of each handover case; i.e. access handling in MSC-A server is not included.

### 8.1.5 SRNS/SBSS Relocation with Iu on IP

If IuCS on IP is supported by the MSC server, the Core Network side procedures described in 8.1.1, 8.1.2, 8.1.3 and 8.1.4 shall apply. For the access bearer termination, the exchange of IP addresses via call control procedures is described in this clause.

Before the MSC server starts the access bearer assignment, the MSC server requests the MGW to prepare for the access bearer using the Prepare\_IP\_Transport procedure. The MSC server requests the MGW to provide an IP Transport address and UDP Port and provides the MGW with the bearer characteristics. For speech calls, the MSC server shall provide the MGW with the speech coding information and conditionally GTT related information in accordance with 3GPP TS 23.226 [28] for the bearer. For a non-speech call the MSC server also provides the MGW with a PLMN Bearer Capability [4]. After the MGW has replied with the IP address and UDP Port the MSC server requests access bearer assignment using the provided IP address and UDP Port in accordance with 3GPP TS 25.413 [26]. The IP addresses and UDP Ports of the MGW and the RNC are exchanged via the RANAP procedures. If the bearer transport is IP and IuUP mode is Transparent, when the MSC receives the RANAP Iu Relocation Request response, it shall send the RNC IP address and UDP Port to the MGW Access bearer termination using the Modify\_IP\_Transport\_Address procedure.

If the bearer transport is IP and IuUP mode is Support, the MGW shall use the source IP address and UDP Port of the IuUP Init packet received from the radio access network as the destination address for subsequent downlink packets.

The sequence is shown in figure 8.1.5/1.

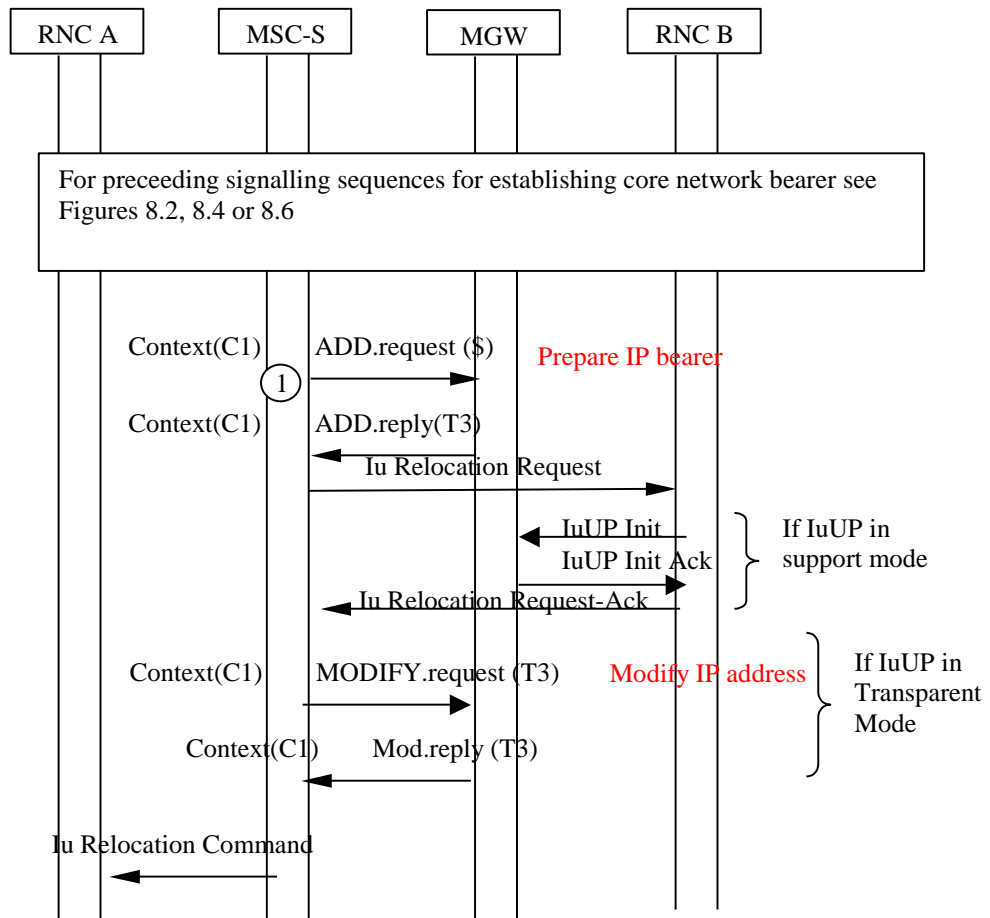


Figure 8.1.5/1 SRNS Relocation with Iu on IP

## 8.1.6 Intra-MSC enhanced SRNS Relocation

### 8.1.6.1 Introduction

The procedures specified in 3GPP TS 23.009 [8] for "Intra-3G\_MSC SRNS Relocation" shall be followed. The following clauses describe the additional requirements for the bearer independent CS core network. The support of the enhanced SRNS Relocation is optional.

### 8.1.6.2 Enhanced Relocation Complete Request

When the Enhanced Relocation Complete Request message is received, the MSC server requests the MGW to provide a binding reference and a bearer address, using the Prepare Bearer procedure. For speech calls, the MSC server shall provide the MGW with the speech coding information for the bearer. For non-speech calls the MSC server also provides the MGW with the same PLMN Bearer Capability [4] as was provided at the last access bearer assignment. The MSC server uses the Change Flow Direction Procedure to request the MGW to set the Handover Device to initial state. If required the MSC Server shall set-up an interconnection between the "anchor" and the "target" MGW. The MSC server then sends the Enhanced Relocation Complete Response message, containing the bearer address and the binding reference, to RNC-B (bullet 1 in figure 8.1.6/2).

### 8.1.6.3 Enhanced Relocation Complete Confirm

When the MSC server receives the Enhanced Relocation Complete Confirm message, the MSC server uses the Change Flow Direction procedure to request the MGW to set the Handover Device to intermediate state (bullet 2 in figure 8.1.6/1).

After that the MSC Server requests RNC-A to release the IU. The MSC server also requests the MGW to set the Handover Device to its final state by removing the bearer termination towards RNC-A, using the Release Termination procedure (bullet 3 in figure 8.1.6/2).

### 8.1.6.4 Interworking function

The interworking function used by the MGW before relocation will also be used after relocation.

### 8.1.6.5 Codec handling

The MGW may include a speech transcoder based upon the speech coding information provided to each bearer termination.

### 8.1.6.6 Voice Processing function

After relocation, the MGW may continue or modify voice-processing function(s) provided to each bearer termination.

### 8.1.6.7 Handling of multiple bearers (multicall)

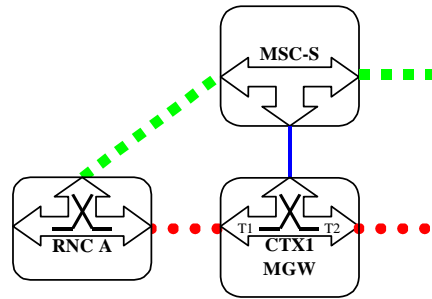
If the UE is engaged with multiple bearers all procedures related to the handling of bearers and terminations described for the relocation of a single bearer shall be repeated for each bearer.

### 8.1.6.8 Failure Handling in MSC server

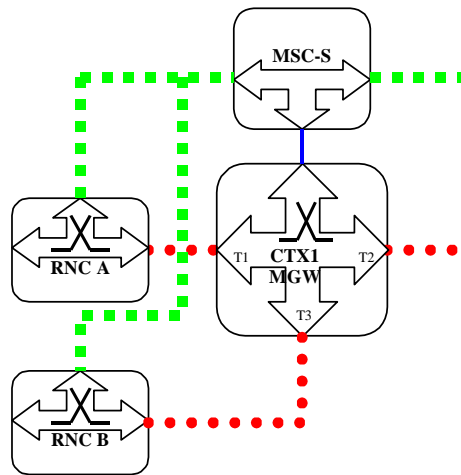
When a procedure between the MSC server and the MGW fails the MSC server shall send an IU-ENHANCED-RELOCATION-COMPLETE-FAILURE message to RNS-B in accordance with 3GPP TS 23.009 [8] and 3GPP TS 29.010 [23]. If MGW resources have been already seized at the target access side then the resources shall be released using the Release Termination procedure. If the call is to be cleared, then it shall be handled as described in clause 7.3.

### 8.1.6.9 Example

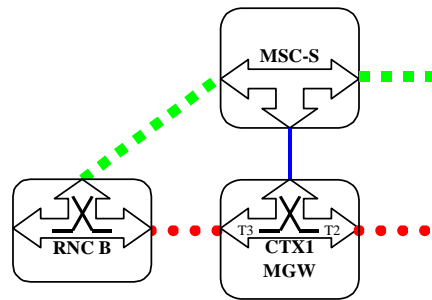
Figure 8.1.6/1 shows the network model for the Intra-MSC enhanced SRNS Relocation. The "squared" line represents the call control signalling. The "dotted" line represents the bearer control signalling and the bearer. The bearer termination T1 is used for the bearer towards RNC-A, bearer termination T3 is used for the bearer towards RNC-B and the bearer termination T2 is used for the bearer towards the succeeding/preceding MGW.



**Before Relocation:**



**After Relocation:**



**After release of Source side resources:**

**Figure 8.1.6/1: Intra-MSC Enhanced SRNS Relocation (network model)**

Figure 8.1.6/2 shows the message sequence example for the Intra-MSC enhanced SRNS Relocation. It is assumed that the Handover Device is located in the MGW, which has been selected for the call establishment by the MSC server. The MSC server controls the call and the mobility management. It is also assumed that only one bearer has been established towards RNC-A.

In the example the MSC server requests seizure of RNC-B side bearer termination with specific flow directions. The MSC server orders the establishment of the bearer by sending Enhanced Relocation Complete Response towards RNC-B. When the MSC server receives an Enhanced Relocation Complete Confirm indication from RNC-B the MSC server requests to change the flow directions between the terminations within the context. MSC Server also orders RNC-A to release the IU. This action causes release of the bearer between the RNC-A and the MGW. Finally the MSC server requests the MGW to release RNC-A side bearer termination.

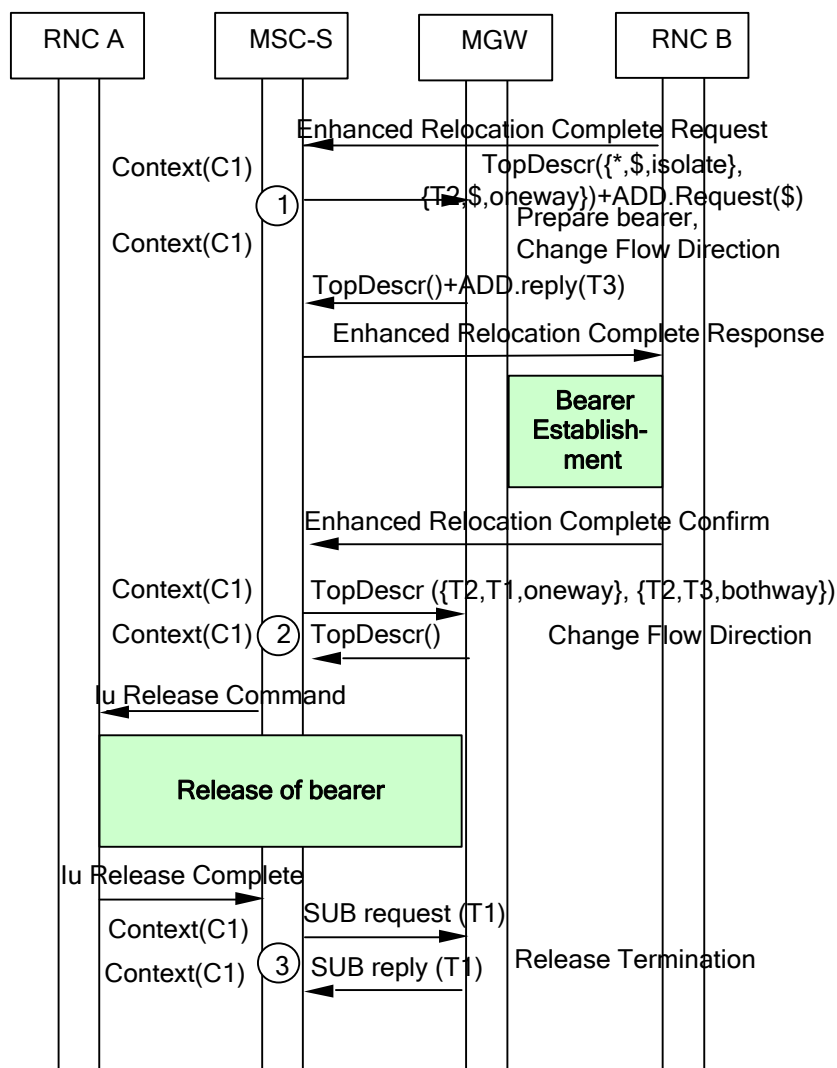


Figure 8.1.6/2: Intra-MSC Enhanced SRNS Relocation (message sequence chart)

### 8.1.7 Intra-MSC enhanced SRNS Relocation with Iu on IP

If IuCS on IP is supported by the MSC server, the Core Network side procedures described in 8.1.x shall apply. For the access bearer termination, the exchange of IP addresses via call control procedures as described in 8.1.5 applies with the following exception. The Prepare\_IP\_Transport procedure is used after the MSC Server receives the RANAP Enhanced Relocation Complete Request. If the bearer transport is IP and IuUP mode is Transparent, when the MSC Server receives the RANAP Enhanced Relocation Complete Response, it shall send the RNC IP address and UDP Port to the MGW Access bearer termination using the Modify\_IP\_Transport\_Address procedure.

The sequence is shown in figure 8.7/1.

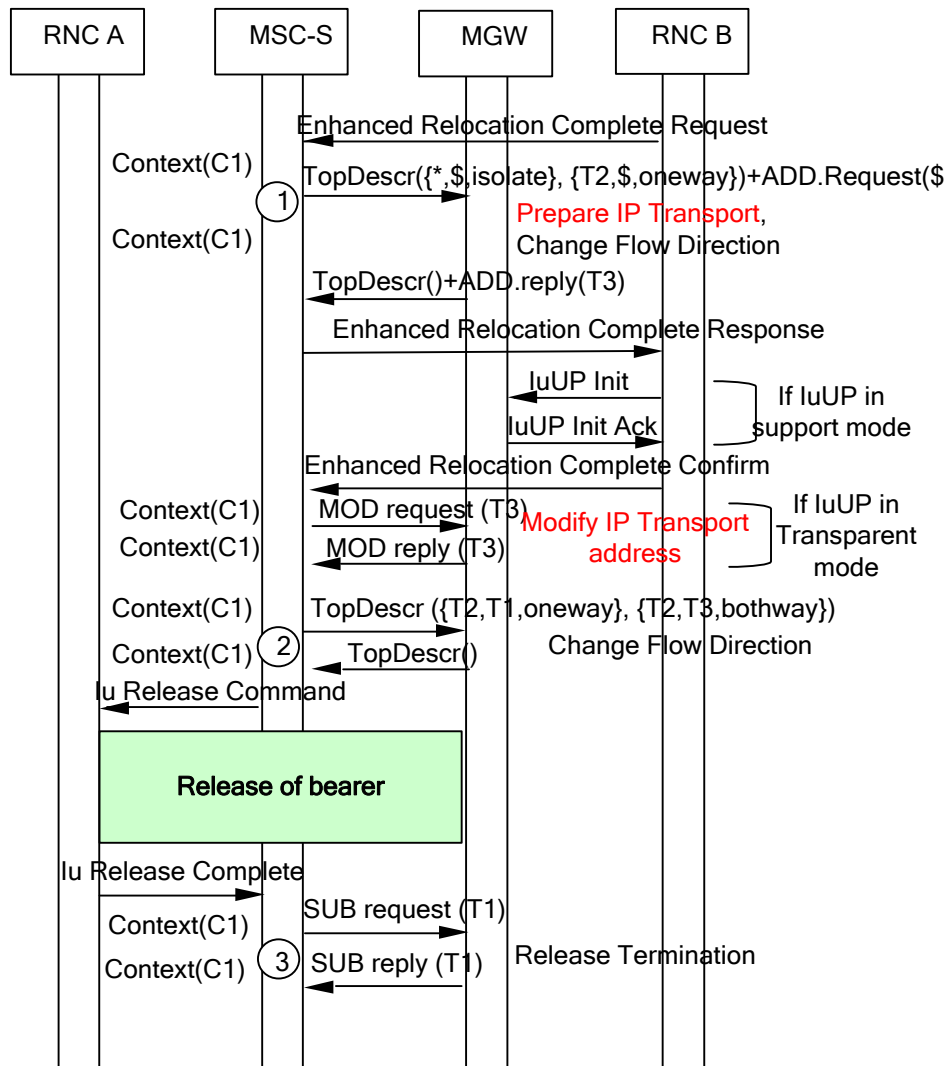


Figure 8.1.7/1 Enhanced SRNS Relocation with Iu on IP

## 8.2 UMTS to GSM

In the context of the following clauses, the terms RNS or RNC refer also to a GERAN BSS or BSC (respectively) when serving an UE in Iu mode.

### 8.2.1 Intra-MSC UMTS to GSM Handover

The procedures specified in 3GPP TS 23.009 [8] for "Intra-3G\_MSC Handover from UMTS to GSM" shall be followed. The following clauses describe the additional requirements for the bearer independent CS core network.

#### 8.2.1.1 Relocation Required

When the MSC server receives the Relocation Required message, it requests the MGW to seize a TDM circuit, using the Reserve Circuit procedure. For non-speech calls the MSC server shall provide the MGW with the GSM Channel coding properties and the same PLMN Bearer Capability [4] as was provided at the last access bearer assignment. The MSC server uses the Change Flow Direction procedure to request the MGW to set the Handover Device to initial state. The MSC server sends the Handover Request message, containing the CIC, to BSC-B (bullet 1 in figure 8.8/1).



### 8.2.1.2 Handover Request Acknowledge

For non-speech calls after receiving the Handover Request Acknowledge message if the assigned GSM Channel coding properties differ from the previously provided ones the MSC server provides the MGW with the assigned GSM Channel coding properties using the Modify Bearer Characteristics procedure (bullet 2 in figure 8.8/1).

### 8.2.1.3 Relocation Command/Handover Detect

When the MSC server sends the Relocation Command message or alternatively if it receives the Handover Detect message, the MSC server uses the Change Flow Direction procedure to requests the MGW to set the Handover Device to intermediate state (bullet 3 in figure 8.8/1).

### 8.2.1.4 Handover Complete

When the MSC server receives the Handover Complete message, it requests RNC-A to release the IU. The MSC server also requests the MGW to set the Handover Device to its final state by removing the bearer termination towards RNC-A, using the Release Termination procedure (bullet 4 in figure 8.8/2).

### 8.2.1.5 Interworking function

The interworking function used by the MGW before handover will also be used after handover.

### 8.2.1.6 Voice Processing function

After handover, the MGW may continue or modify voice processing function(s) provided to each bearer termination.

### 8.2.1.7 Handling of multiple bearers (multicall)

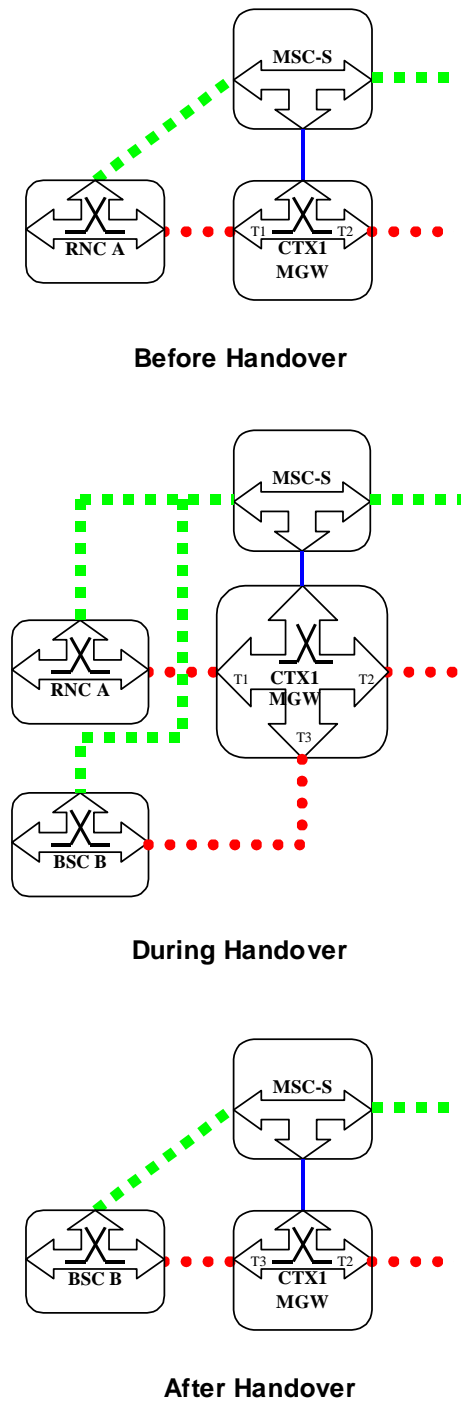
If the UE is engaged with multiple bearers then one bearer is selected to be handed over according to 3GPP TS 23.009 [8]. The calls carried by the bearers that have not been selected will be cleared after the reception of the Handover Complete message, as described in clause 7.3.

### 8.2.1.8 Failure Handling in MSC server

When a procedure between the MSC server and the MGW fails the MSC server shall handle the failure as an internal error in accordance with 3GPP TS 23.009 [8] and 3GPP TS 29.010 [23]. If MGW resources have been already seized at the target access side then the resources shall be released using the Release Termination procedure. If the call is to be cleared, then it shall be handled as described in clause 7.3.

### 8.2.1.9 Example

Figure 8.7 shows the network model for the Intra-MSC UMTS to GSM Handover. The "squared" line represents the call control signalling. The "dotted" line represents the bearer control signalling (not applicable in case of GSM access) and the bearer. The bearer termination T1 is used for the bearer towards RNC-A, bearer termination T3 is used for the bearer towards BSC-B and the bearer termination T2 is used for the bearer towards the succeeding/preceding MGW.



**Figure 8.7: Intra-MSC UMTS to GSM Handover (network model)**

Figure 8.8 shows the message sequence example for the Intra-MSC UMTS to GSM Handover.

It is assumed that the Handover Device is located in the MGW selected for the call establishment by the MSC server, which controls the call and the mobility management. It is also assumed that only one bearer has been established towards RNC-A and that MGW-A is capable of handling GSM access.

In the example the MSC server requests seizure of BSC-B side bearer termination with specific flow directions. The MSC server starts handover execution by sending Handover Request towards BSC-B. When the handover is detected in BSC-B the MSC server requests to change the flow directions between the terminations within the context. When MSC server receives Handover Complete indication from BSC-B it orders RNC-A to release the IU. Finally the MSC server requests the MGW to release RNC-A side bearer termination.

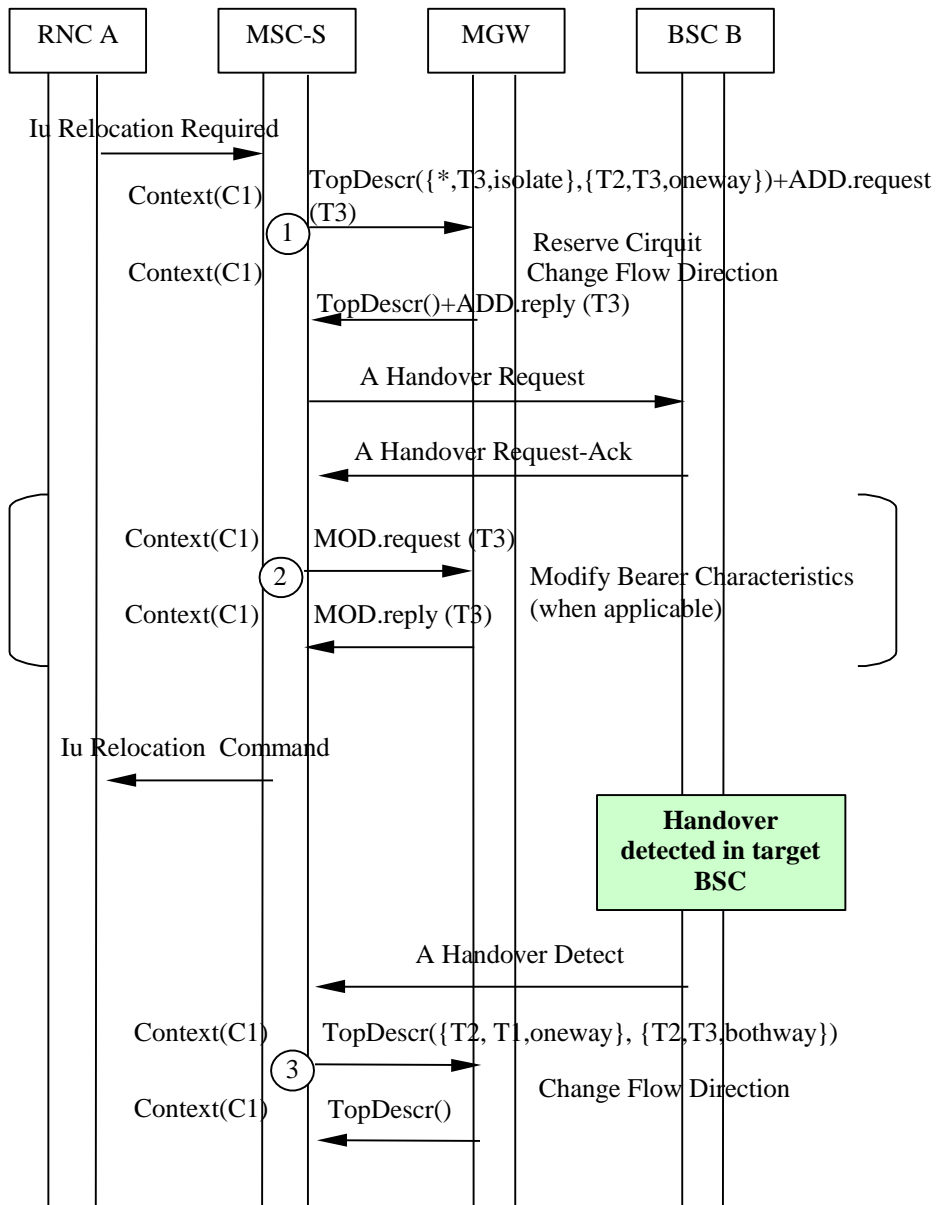


Figure 8.8/1: Intra-MSC UMTS to GSM Handover (message sequence chart)

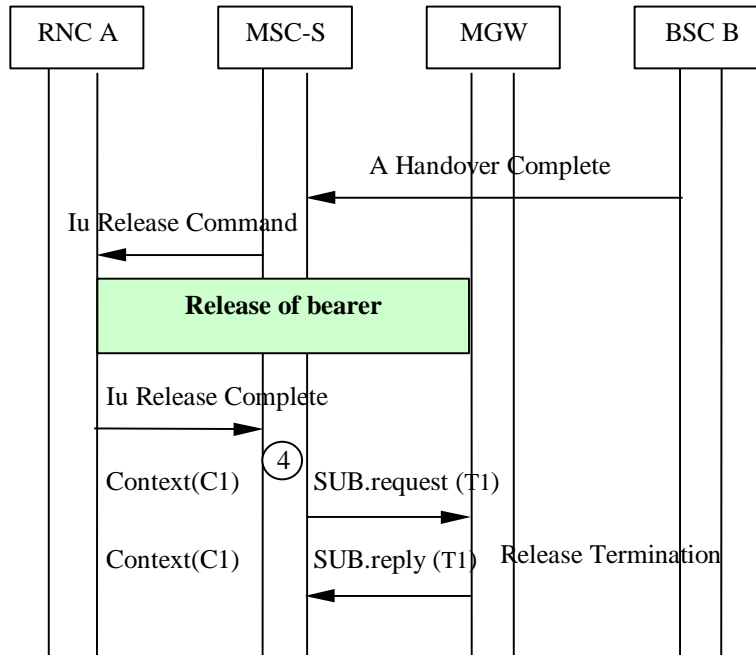


Figure 8.8/2: Intra-MSC UMTS to GSM Handover (message sequence chart)

8.2.1.10 Intra-MSC UMTS to GSM Handover for A interface over IP

When the MSC server receives the RANAP Relocation Required message, it requests the MGW to reserve an RTP bearer termination using the Reserve RTP Connection Point procedure. The MSC server requests the MGW to reserve an IP address and UDP port. The MSC server uses the Change Flow Direction procedure to request the MGW to set the Handover Device to initial state.

The MGW reserves the RTP termination and indicates the IP address and UDP port number to the MSC server. The IP addresses and UDP ports of the MGW is sent to the BSC in the BSSMAP Handover Request message. When the MSC server receives the BSSMAP Handover Request-Ack message, it shall send the BSC IP address and UDP Port number to the MGW using the Configure RTP Connection Point procedure.

The sequence is shown in Figure 8.2.1.10/1.

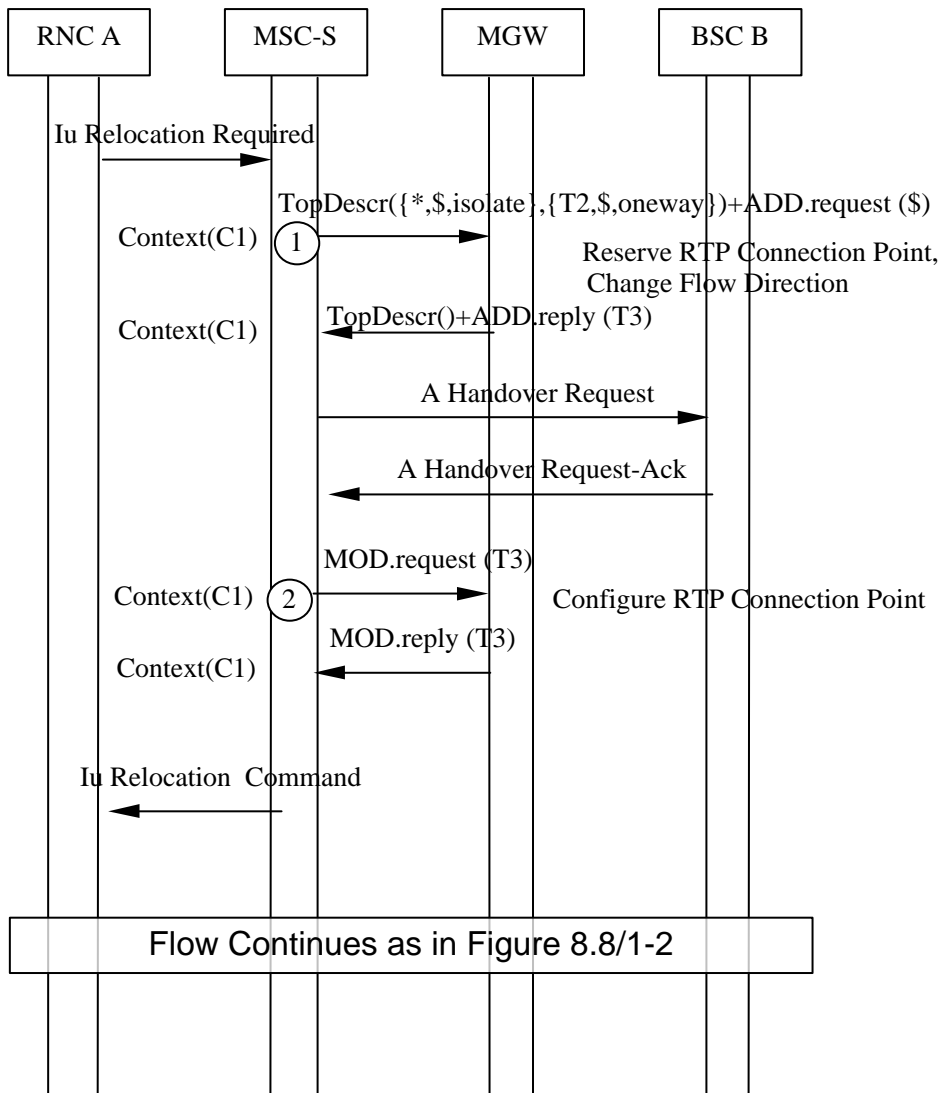


Figure 8.2.1.10/1: Intra-MSC UMTS to GSM Handover for AoIP (message sequence chart)

## 8.2.2 Basic Inter-MSC UMTS to GSM Handover

The procedures specified in 3GPP TS 23.009 [8] for "Basic Handover Procedure Requiring a Circuit Connection between 3G\_MSC-A and MSC-B" shall be followed. The following clauses describe the additional requirements for the bearer independent CS core network.

### 8.2.2.1 MSC-A/ MGW-A

#### 8.2.2.1.1 Bearer establishment between MGW-A and MGW-B

The handling of the bearer establishment between MGW-A and MGW-B is as described for a Basic Mobile Originating Call, using either forward or backward bearer establishment. For non-speech calls the MSC-A server shall provide MGW-A with the GSM Channel coding properties and the same PLMN Bearer Capability [4] as was provided at the last access bearer assignment. The MSC-A server also uses the Change Flow Direction procedure to request MGW-A to set the Handover Device to initial state (bullet 3 in figure 8.10/1).

#### 8.2.2.1.2 Relocation Command/Handover Detect

When the MSC-A server sends the Relocation Command message or alternatively if it receives the Handover Detect message, the MSC-A server uses the Change Flow Direction procedure to requests the MGW to set the Handover Device to intermediate state (bullet 2 in figure 8.10/1).

### 8.2.2.1.3 Handover Complete

When the MSC-A server receives the Relocation Complete message, it requests RNC-A to release the IU. The MSC-A also requests the MGW to set the Handover Device to its final state by removing the bearer termination towards RNC-A, using the Release Termination procedure (bullet 3 in figure 8.10/1).

### 8.2.2.1.4 Interworking function

The interworking function used by MGW -A before handover will also be used after handover.

### 8.2.2.1.5 Voice Processing function

Voice processing function(s) provided by MGW -A before handover, may be continued or modified by MGW -A and/or MGW -B after handover.

### 8.2.2.1.6 Handling of multiple bearers (multicall)

If the UE is engaged with multiple bearers then one bearer is selected to be handed over according to 3GPP TS 23.009 [8]. The calls carried by bearers that have not been selected will be cleared after the reception of Handover Complete message, as described in clause 7.3.

### 8.2.2.1.7 Failure Handling in MSC server

When a procedure between the MSC-A server and MGW -A fails the MSC-A server shall handle the failure as an internal error in accordance with 3GPP TS 23.009 [8] and 3GPP TS 29.010 [23]. If MGW -A resources have been already seized for the bearer towards MGW -B then the resources shall be released using the Release Termination procedure. The call towards MSC-B server shall be cleared as described in clause 7.3. If the original call is to be cleared, then it shall be handled as described in clause 7.3.

## 8.2.2.2 MSC-B/MGW-B

### 8.2.2.2.1 MGW selection

The MSC-B server selects an MGW when it receives Prepare Handover Request message (bullet 1 in figure 8.10/1).

### 8.2.2.2.2 Bearer establishment towards BSC-B

When the MSC-B server has selected MGW-B it requests MGW-B to seize a TDM circuit, using the Reserve Circuit procedure. The MSC-B server sends the Handover Request message to the BSC-B containing the CIC (bullet 2 in figure 8.10/1).

### 8.2.2.2.3 Bearer establishment between MGW-A and MGW-B

The handling of the bearer establishment between MGW -A and MGW -B is as described for a Basic Mobile Terminating Call, using either forward or backward bearer establishment.

### 8.2.2.2.4 Voice Processing function

Voice processing function(s) provided by MGW -A before handover, may be continued or modified by MGW -B after handover.

### 8.2.2.2.5 Failure Handling in MSC server

When a procedure between the MSC-B server and MGW-B fails the MSC-B server shall handle the failure as an internal error in accordance with 3GPP TS 23.009 [8] and 3GPP TS 29.010 [23]. If MGW-B resources have already been seized at the target access side then the resources shall be released using the Release Termination procedure. The call from MSC-A server shall be released as described at subclause 7.1.

8.2.2.2.6 Example

Figure 8.9 shows the network model for the Basic Inter-MSC UMTS to GSM Handover. The "squared" line represents the call control signalling. The "dotted" line represents the bearer control signalling (not applicable in case of GSM access) and the bearer. In MGW-A the bearer termination T1 is used for the bearer towards RNC-A, bearer termination T3 is used for the bearer towards MGW-B, and the bearer termination T2 is used for the bearer towards the succeeding/preceding MGW. In MGW-B the bearer termination T4 is used for the bearer towards BSC-B, bearer termination T5 is used for the bearer towards MGW-A.

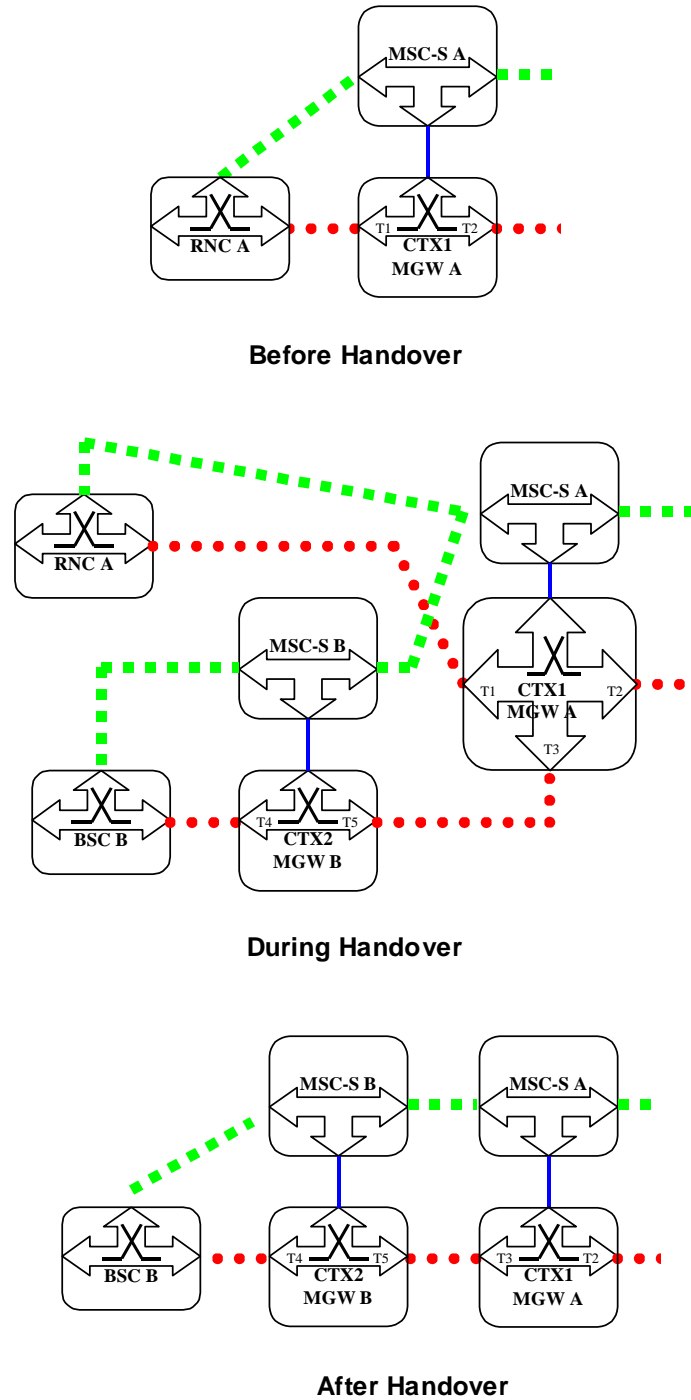


Figure 8.9: Basic Inter-MSC UMTS to GSM Handover (network model)

Figure 8.10 shows the message sequence example for the Basic Inter-MSC UMTS to GSM Handover. It is assumed that the Handover Device is located in the MGW (MGW -A) which has been selected for the call establishment by the MSC server (MSC-A server). The MSC server controls the call and the mobility management. It is also assumed that only one bearer has been established towards RNC-A.

In the example the MSC-B server requests MGW-B to seize BSC-B side bearer termination. The call is established between MSC-A server and MSC-B server, and the bearer is established between MGW-A and MGW-B. When the handover is detected in BSC-B the MSC-A server requests to change the flow directions between the terminations within the context in MGW-A. When MSC-A server receives Handover Complete indication from MSC-B server it orders RNC-A to release the IU. Finally MSC-A server requests MGW-A to remove RNC-A side bearer termination.

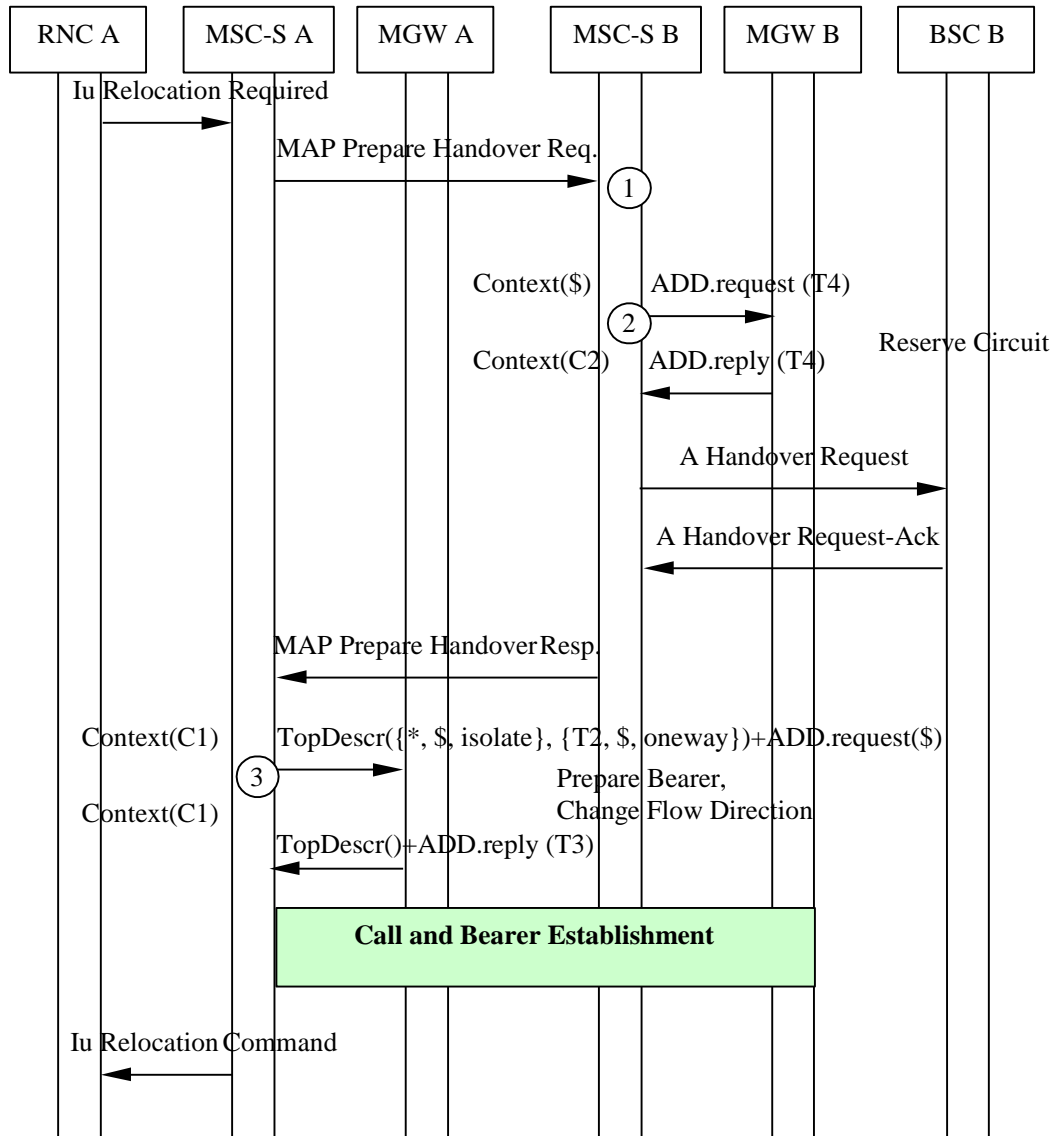


Figure 8.10/1: Basic Inter-MSC UMTS to GSM Handover (message sequence chart)



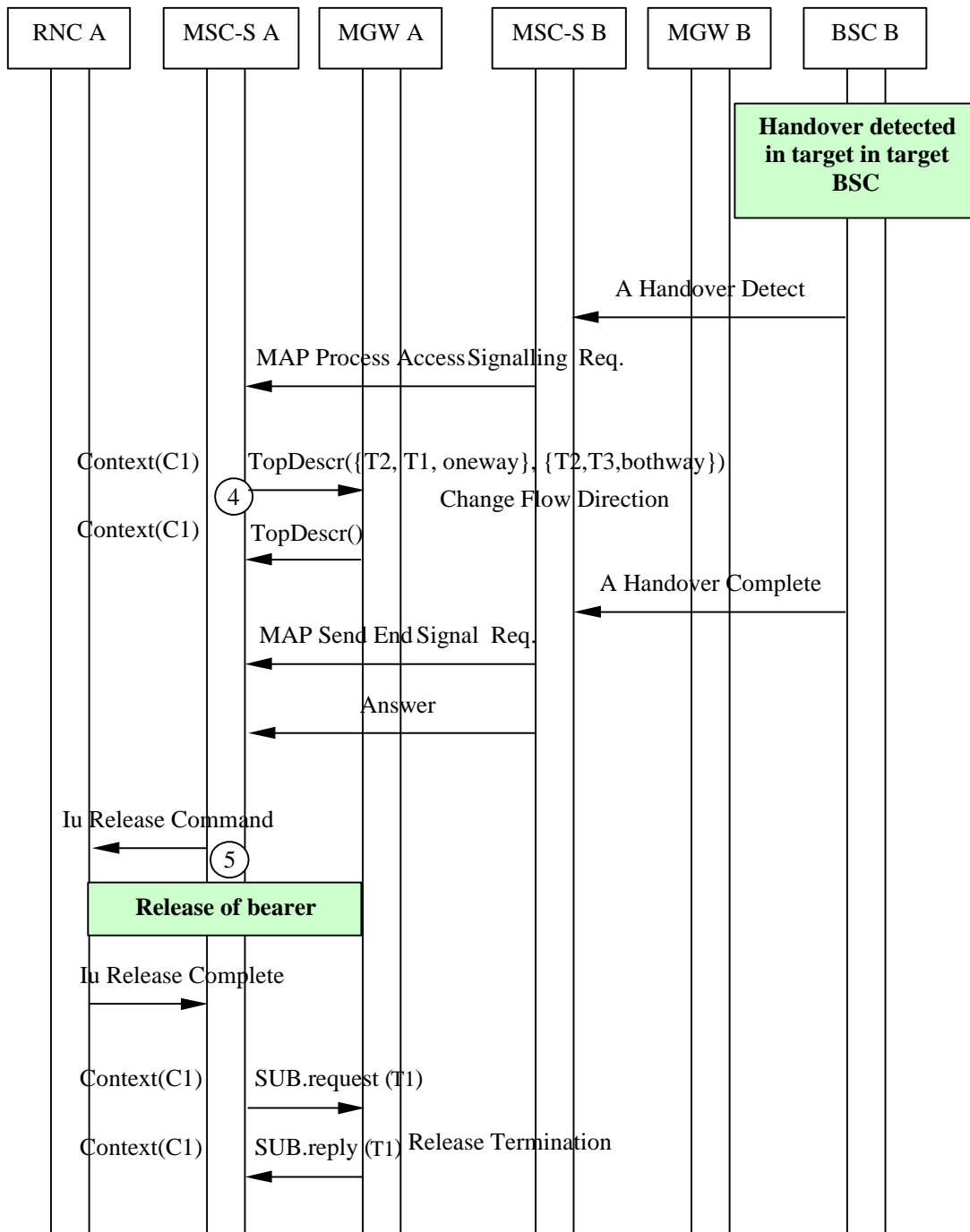


Figure 8.10/2: Basic Inter-MSC UMTS to GSM Handover (message sequence chart)

### 8.2.2.3 Basic Inter-MSC UMTS to GSM Handover for A Interface over IP

If AoIP is supported by the MSC server, the Core Network side procedures described earlier in 8.2.2 shall apply. For the access side termination, the exchange of IP addresses via call control procedures is described in this clause.

When the MSC-B server receives the MAP Prepare Handover Request., it requests the MGW-B to reserve an RTP bearer termination using the Reserve RTP Connection Point procedure. The MSC-B server requests the MGW-B to reserve an IP address and UDP port.

The MGW-B reserves the RTP termination and indicates the IP address and UDP port number to the MSC-B server. The IP addresses and UDP ports of the MGW is sent to the BSC-B in the BSSMAP Handover Request message. When the MSC-B server receives the BSSMAP Handover Request-Ack message, it shall send the BSC-B IP address and UDP Port number to the MGW-B using the Configure RTP Connection Point procedure.

The sequence is shown in Figure 8.2.2.3/1.

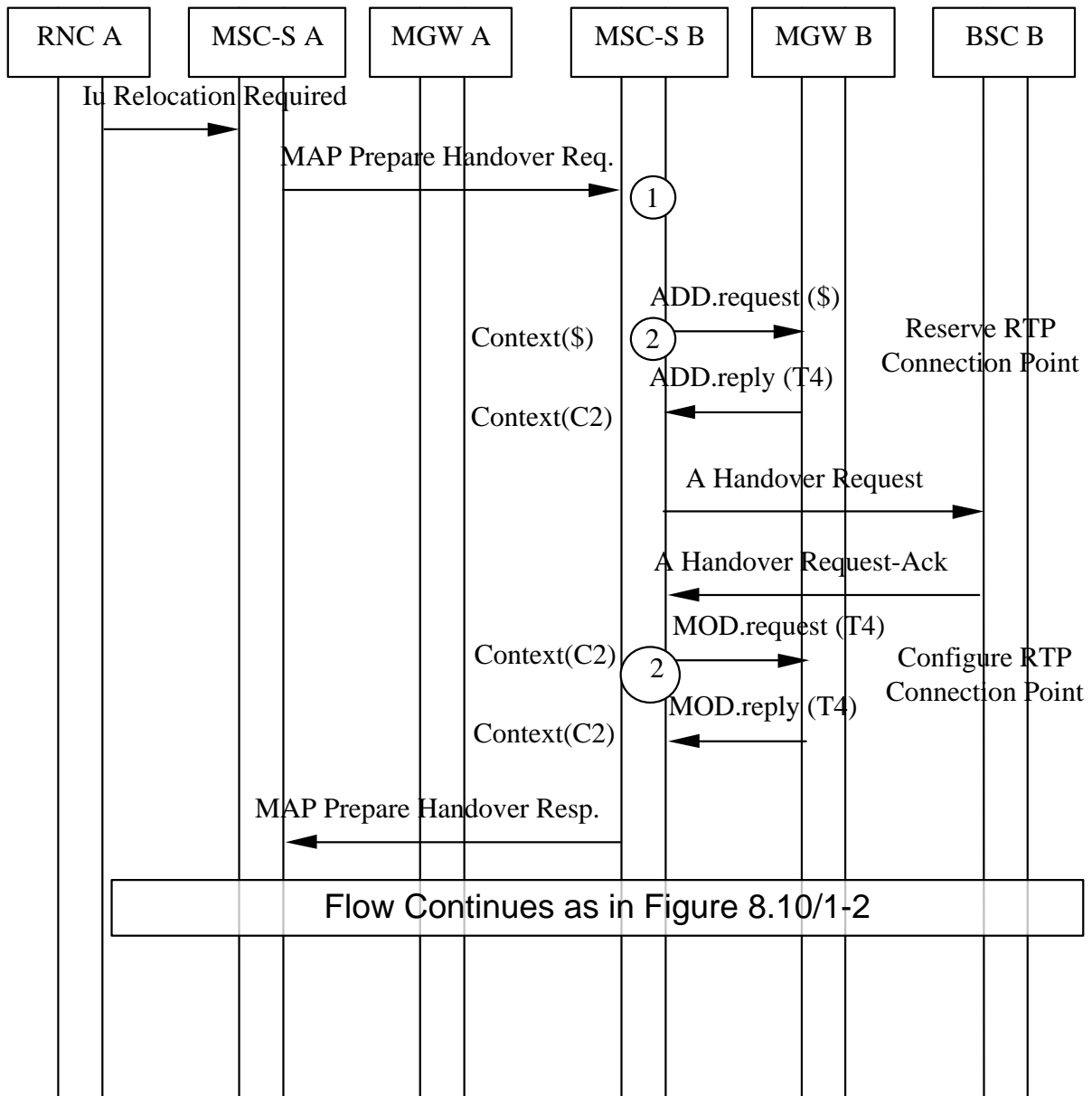


Figure 8.2.2.3/1: Basic Inter-MSC UMTS to GSM Handover for AoIP (message sequence chart)

### 8.2.3 Subsequent Inter-MSC UMTS to GSM Handover back to the Anchor MSC

The following handling shall be applied for a call that started as UMTS call. The procedures specified in 3GPP TS 23.009 [8] for "Subsequent UMTS to GSM handover requiring a Circuit Connection between 3G\_MSC-A and 3G\_MSC-B, 3G\_MSC-B to MSC-A" shall be followed. The following clauses describe the additional requirements for the bearer independent CS core network.

#### 8.2.3.1 MSC-A

##### 8.2.3.1.1 Handover Request

When the MSC-A server receives the MAP Prepare Subsequent Handover request containing a Handover Request message, it requests MGW-A to seize a TDM circuit, using the Reserve Circuit procedure. For non-speech calls the MSC-A server shall provide MGW-A with the GSM Channel coding properties and the same PLMN Bearer Capability

[4] as was provided at the first access bearer assignment. The MSC-A server uses the Change Flow Direction procedure to request MGW-A to set the Handover Device to initial state. The MSC-A server sends the Handover Request message, containing the CIC, to BSC-B (bullet 1 in figure 8.12/1).

#### 8.2.3.1.2 Handover Request Acknowledge

For non-speech calls after receiving the Handover Request Acknowledge message if the assigned GSM Channel coding properties differ from the previously provided ones the MSC-A server shall provide MGW-A with the assigned GSM Channel coding properties using the Modify Bearer Characteristics procedure (bullet 2 in figure 8.12/1).

#### 8.2.3.1.3 Relocation Command/Handover Detect

When the MSC-A server sends the MAP Prepare Subsequent Handover response message or alternatively if it receives the Handover Detect message, the MSC-A server uses the Change Flow Direction procedure to requests MGW-A to set the Handover Device to intermediate state (bullet 3 in figure 8.12/2).

#### 8.2.3.1.4 Handover Complete

When the MSC-A server receives the Handover Complete message, it informs the MSC-B server about reception of this message (bullet 3 in figure 8.12/2). The MSC-A server then initiates call clearing towards the MSC-B server as described at 7.3.

#### 8.2.3.1.5 Interworking function

The interworking function used by MGW-A before handover will also be used after handover.

#### 8.2.3.1.6 Voice Processing function

Voice processing function(s) provided by MGW-A and MGW-B before handover, may be continued or modified by MGW-A after handover.

#### 8.2.3.1.7 Handling of multiple bearers (multicall)

If the UE is engaged with multiple bearers the selected bearer to be handed over is received from MSC-B server in the Handover Request message according to 3GPP TS 23.009 [8]. The calls carried by the bearers that have not been selected will be cleared by MSC-A server after the reception of the Handover Complete message, as described in clause 7.3.

#### 8.2.3.1.8 Failure Handling in MSC server

When a procedure between the MSC-A server and the MGW fails the MSC-A server shall handle the failure as an internal error in accordance with 3GPP TS 23.009 [8] and 3GPP TS 29.010 [23]. If MGW resources have already been seized at the target access side then the resources shall be released using the Release Termination procedure. If the call is to be cleared, then it shall be handled as described in clause 7.3.

### 8.2.3.2 MSC-B

#### 8.2.3.2.1 Handover Complete

When the MSC-B server receives the Handover Complete message, it requests RNC-A to release the IU. The MSC-B server also requests MGW-B to remove the bearer termination towards RNC-A using the Release Termination procedure (bullet 4 in figure 8.12/2).

#### 8.2.3.2.2 Release of bearer towards MGW-A

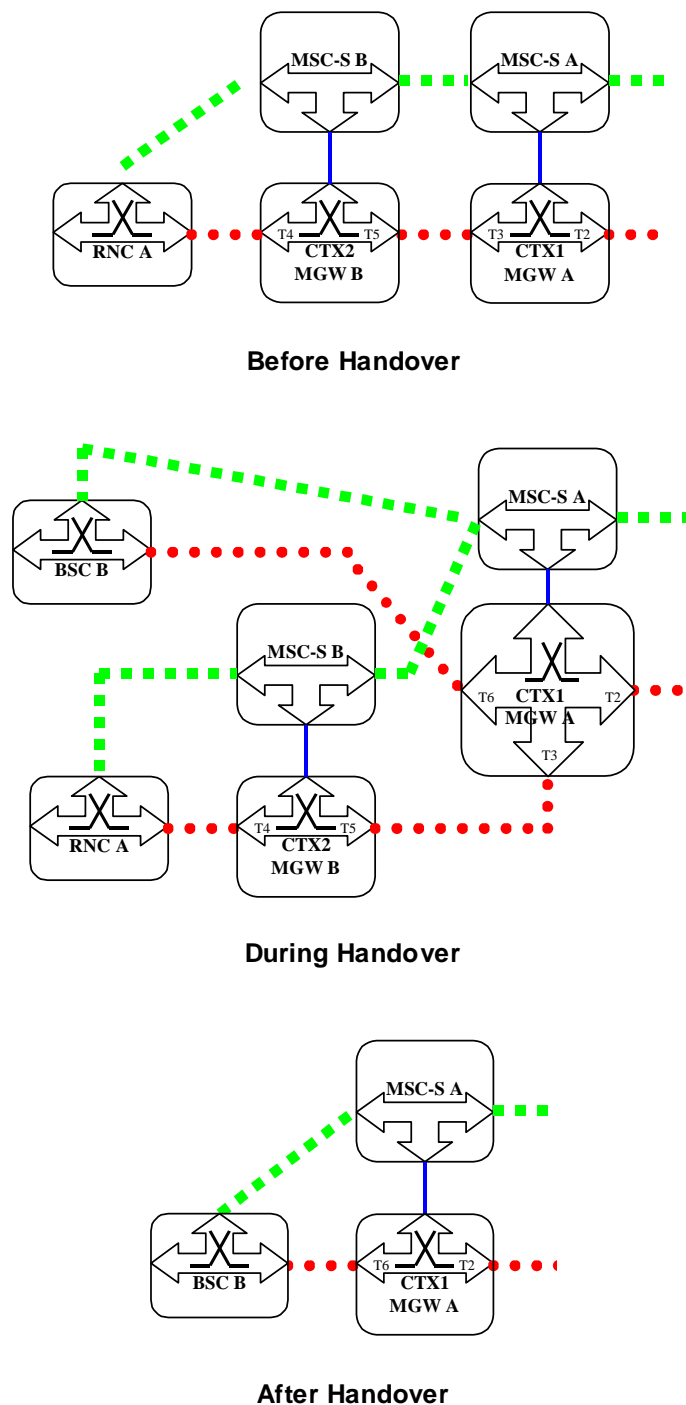
When the MSC-B server receives a call clearing indication from the MSC-A server, the MSC-B server handles it as described in clause 7.2.

8.2.3.2.3 Handling of multiple bearers (multicall)

If the UE is engaged with multiple bearers then one bearer is selected by MSC-B server to be handed over according to 3GPP TS 23.009 [8].

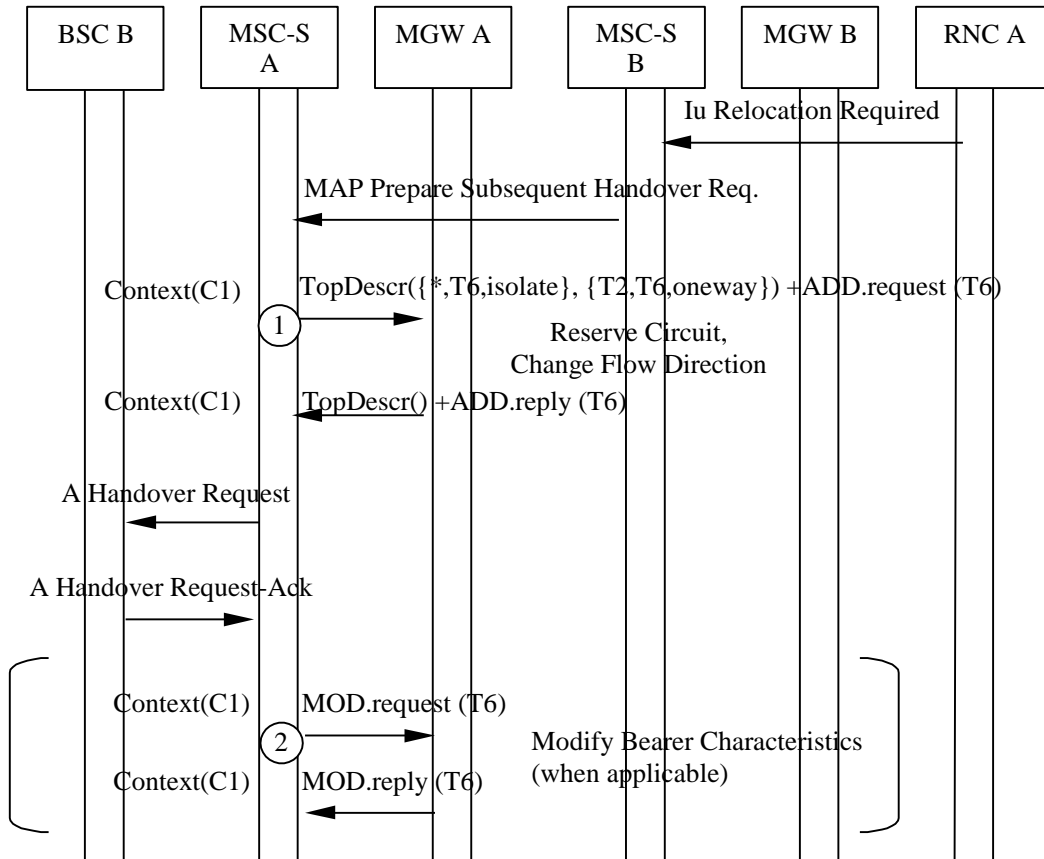
8.2.3.2.4 Example

Figure 8.11 shows the network model for the Subsequent Inter-MSC UMTS to GSM handover back to the Anchor MSC. The "squared" line represents the call control signalling. The "dotted" line represents the bearer control signalling (not applicable in case of GSM access) and the bearer. In MGW -A the bearer termination T6 is used for the bearer towards BSC-B, bearer termination T3 is used for the bearer towards MGW -B, and the bearer termination T2 is used for the bearer towards the succeeding/preceding MGW. In MGW -B the bearer termination T4 is used for the bearer towards RNC-A, bearer termination T5 is used for the bearer towards MGW -A.



**Figure 8.11: Subsequent Inter-MSC UMTS to GSM Handover back to the Anchor MSC (network model)**

Figure 8.12 shows the message sequence example for the Subsequent Inter-MSC UMTS to GSM Handover back to the Anchor MSC. It is assumed that the Handover Device is located in the MGW (MGW-A) selected for the call establishment by the MSC server (MSC-A server) which controls the call and the mobility management. Also assumed that only one bearer has been established towards RNC-A and that MGW-A is capable to handle GSM access. In the example the MSC-A server requests MGW-A to seize BSC-B side bearer termination with specific flow directions. When the relocation is detected in BSC-B the MSC-A server requests to change the flow directions between the terminations within the context in MGW-A. When MSC-A server receives Handover Complete indication from BSC-B it transfers this indication to MSC-B server. MSC-B server orders RNC-A to release the IU. MSC-A server initiates call clearing towards MSC-B server.



**Figure 8.12/1: Subsequent Inter-MSC UMTS to GSM Handover back to the Anchor MSC (message sequence chart)**

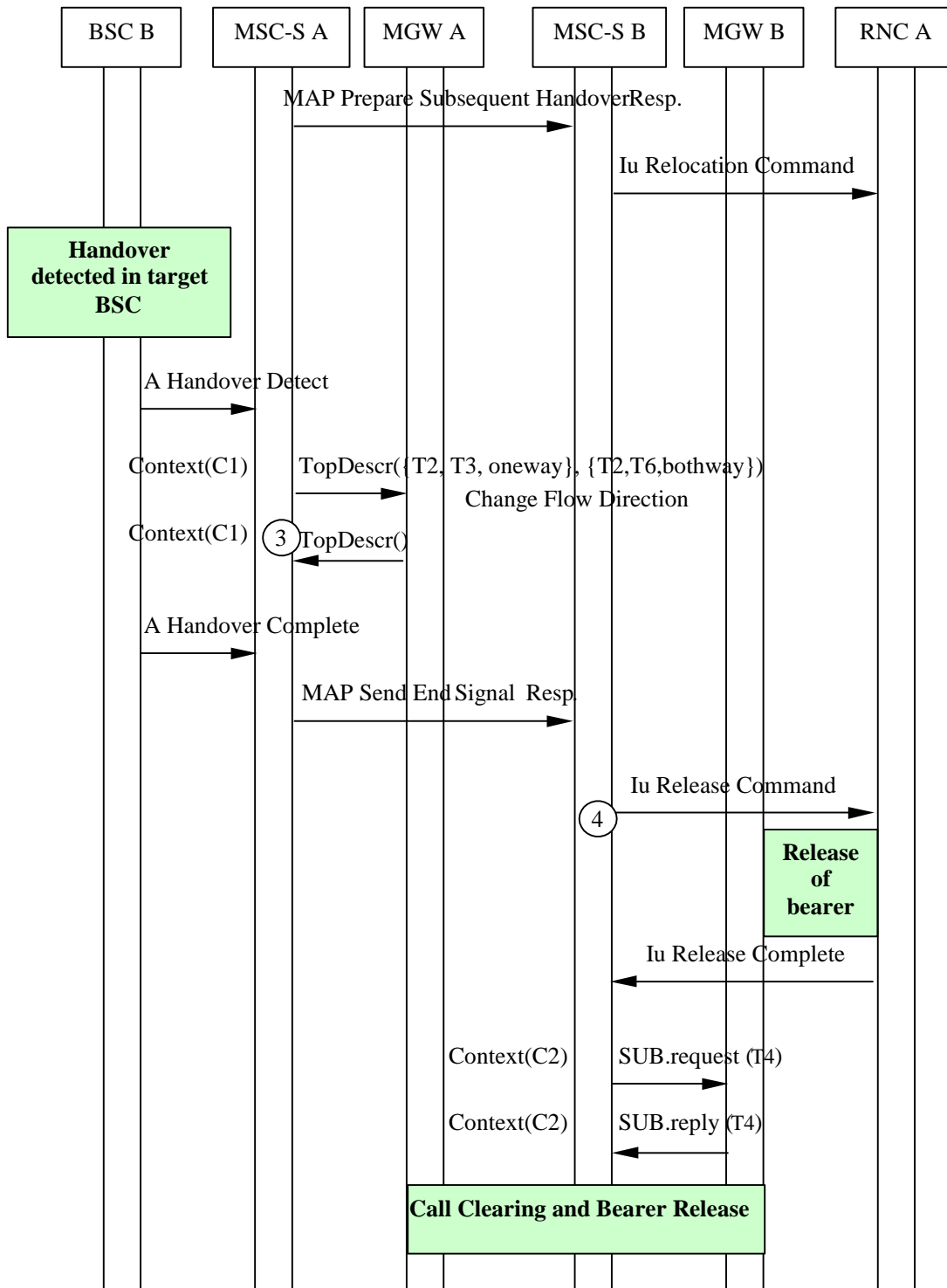


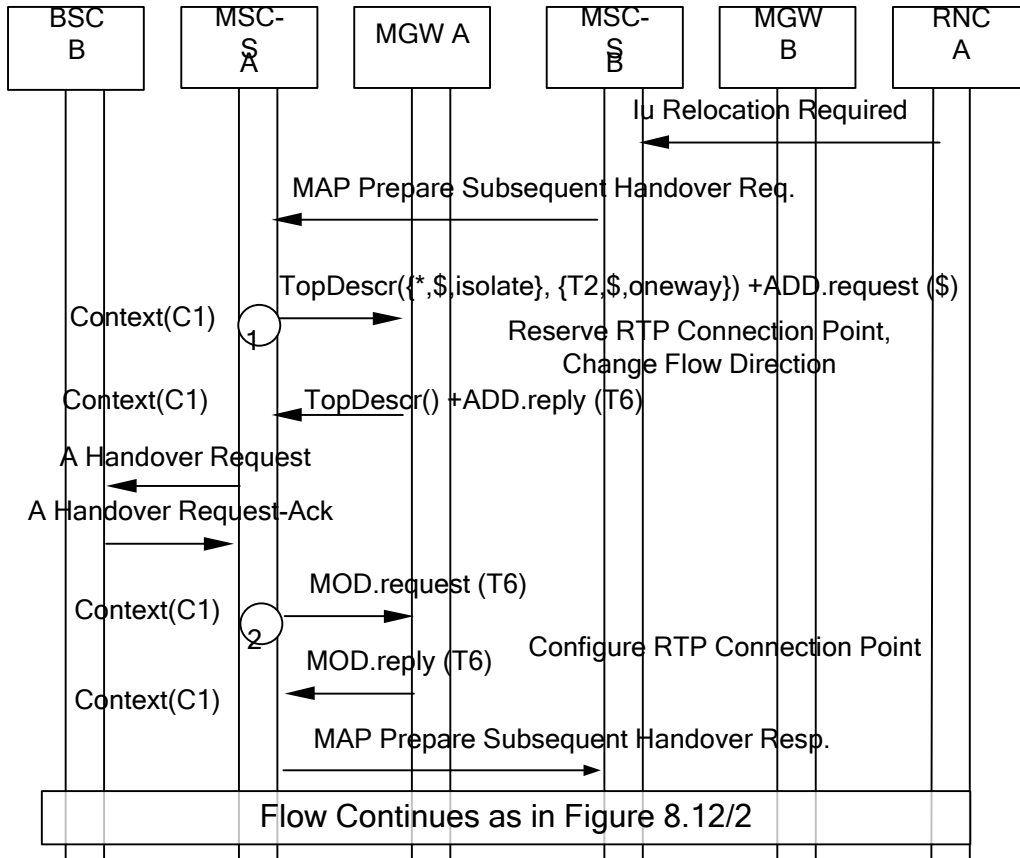
Figure 8.12/2: Subsequent Inter-MSC UMTS to GSM Handover back to the Anchor MSC (message sequence chart)

### 8.2.3.3 Subsequent Inter-MSC UMTS to GSM Handover back to the anchor MSC for A Interface over IP

When the MSC-A server receives the MAP Prepare Subsequent Handover Request. message, it requests the MGW -A to reserve an RTP bearer termination using the Reserve RTP Connection Point procedure. The MSC-A server requests the MGW -A to reserve an IP address and UDP port. The MSC-A server uses the Change Flow Direction procedure to request the MGW-A to set the Handover Device to initial state.

The MGW-A reserves the RTP termination and indicates the IP address and UDP port number to the MSC-A server. The IP addresses and UDP ports of the MGW-A is sent to the BSC-B in the BSSMAP Handover Request message. When the MSC-A server receives the BSSMAP Handover Request-Ack message, it shall send the BSC-A IP address and UDP Port number to the MGW-B using the Configure RTP Connection Point procedure.

The sequence is shown in Figure 8.2.3.3/1.



**Figure 8.2.3.c.1: Subsequent Inter-MSC UMTS to GSM Handover back to the anchor MSC for AoIP (message sequence chart)**

### 8.2.4 Subsequent Inter-MSC UMTS to GSM Handover to a third MSC

The UMTS to GSM handover to a third MSC server (from MSC-B server to MSC-B server) is the combination of the two previous inter-MSC handover cases:

- for MSC-B server a subsequent UMTS to GSM handover from MSC-B server back to MSC-A server as described in clause 8.2.3; and
- for MSC-B server a basic UMTS to GSM handover from MSC-A server to MSC-B server as described in clause 8.2.2.

MSC-A server implements the corresponding parts of each handover case; i.e. access handling in MSC-A server is not included.

## 8.3 GSM to UMTS

In the context of the following clauses, the terms RNS or RNC refer also to a GERAN BSS or BSC (respectively) when serving an UE in Iu mode.

## 8.3.1 Intra-MSC GSM to UMTS Handover

The procedures specified in 3GPP TS 23.009 [8] for "Intra-3G\_MSC GSM to UMTS Handover" shall be followed. The following clauses describe the additional requirements for the bearer independent CS core network.

### 8.3.1.1 Handover Required

When the MSC server receives the Handover Required message, it requests the MGW to provide a binding reference and a bearer address using the Prepare Bearer procedure. For speech calls, the MSC server shall provide the MGW with the speech coding information for the bearer. For non-speech calls the MSC server shall provide the MGW with the same PLMN Bearer Capability [4] as was provided at the last channel assignment. The MSC server uses the Change Flow Direction procedure to request the MGW to set the Handover Device to initial state. The MSC server sends the Relocation Request message to the RNC-B containing the bearer address and binding reference (bullet 1 in figure 8.14).

For Relocation towards GERAN Iu mode the GERAN capabilities of the target cell will be indicated to the MSC-Server within the Handover Required message if the target cell provides different capabilities than the current cell. If no information about the GERAN capabilities of the target cell are received within this message, the MSC-Server shall assume that the GERAN target cell will provide the same capabilities as the current cell (for details see [29]). The MSC server shall indicate to GERAN the selected services within the RANAP RELOCATION REQUEST message. The MSC server shall not set codec information in the NAS Synchronisation Indicator (see [4]). Instead it shall set codec information in the GERAN BSC container.

### 8.3.1.2 Handover Command/Relocation Detect

When the MSC server sends the Handover Command message or alternatively if it receives a Relocation Detect message, the MSC server uses the Change Flow Direction procedure to request the MGW to set the Handover Device to intermediate state (bullet 2 in figure 8.14).

### 8.3.1.3 Relocation Complete

When the MSC server receives the Relocation Complete message, it releases the A-interface line towards BSC-A and requests the MGW to set the Handover Device to its final state removing the bearer termination towards BSC-A, using Release Termination procedure (bullet 3 in figure 8.14).

### 8.3.1.4 Interworking function

The interworking function used by the MGW before handover will also be used after handover.

### 8.3.1.5 Codec handling

The MGW may include a speech transcoder based upon the speech coding information provided to each bearer termination.

### 8.3.1.6 Voice Processing function

After handover, the MGW may continue or modify voice processing function(s) provided to each bearer termination.

### 8.3.1.7 Failure Handling in MSC server

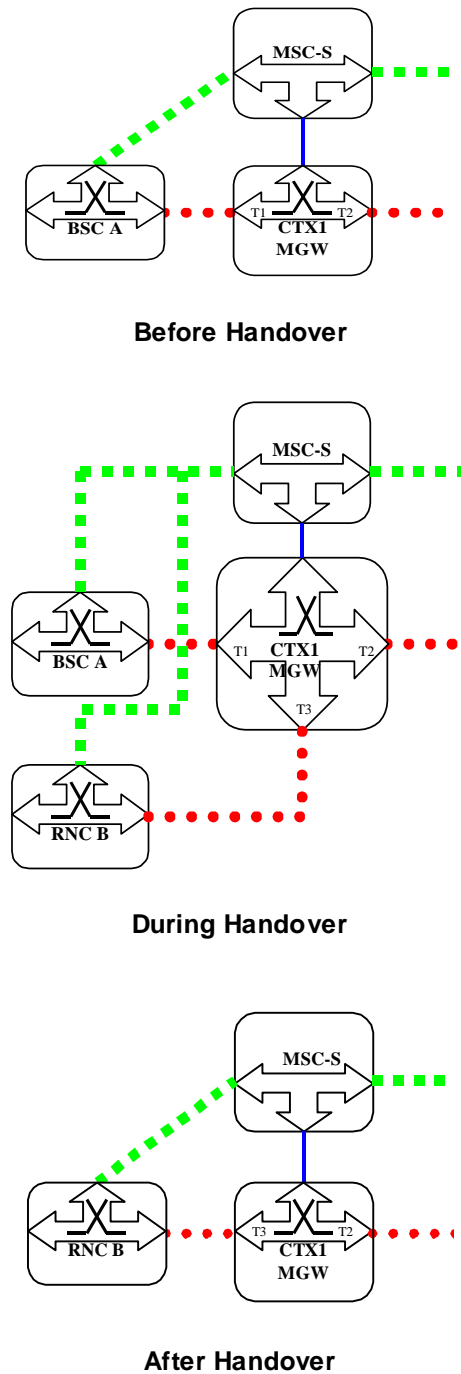
When a procedure between the MSC server and the MGW fails the MSC server shall handle the failure as an internal error in accordance with 3GPP TS 23.009 [8] and 3GPP TS 29.010 [23]. If MGW resources have already been seized at the target access side then the resources shall be released using the Release Termination procedure. If the call is to be cleared, then it shall be handled as described in clause 7.3.

### 8.3.1.8 Example

Figure 8.13 shows the network model for the Intra-3G\_MSC GSM to UMTS Handover. The "squared" line represents the call control signalling. The "dotted" line represents the bearer control signalling and the bearer. The bearer termination T1 is used for the bearer towards the BSC-A (connected through the MSC server), the bearer termination



T3 is used for the bearer towards the RNC-B and the bearer termination T2 is used for the bearer towards the succeeding/preceding MGW.



**Figure 8.13: Intra-3G\_MSC GSM to UMTS Handover (network model)**

Figure 8.14 shows the message sequence example for the Intra-MSC GSM to UMTS Handover. It is assumed that the Handover Device is located in the MGW selected for the call establishment by the MSC server, which controls the call and the mobility management. In the example the MSC server requests seizure of RNC-B side bearer termination with specific flow directions. The MSC server starts handover execution by sending Relocation Request towards RNC-B. When the relocation is detected in RNC-B the MSC server requests to change the flow directions between the terminations within the context. When MSC server receives Relocation Complete indication from RNC-B it releases the A-interface line towards the BSC-A. Finally the MSC server requests the MGW to release BSC-A side bearer termination.

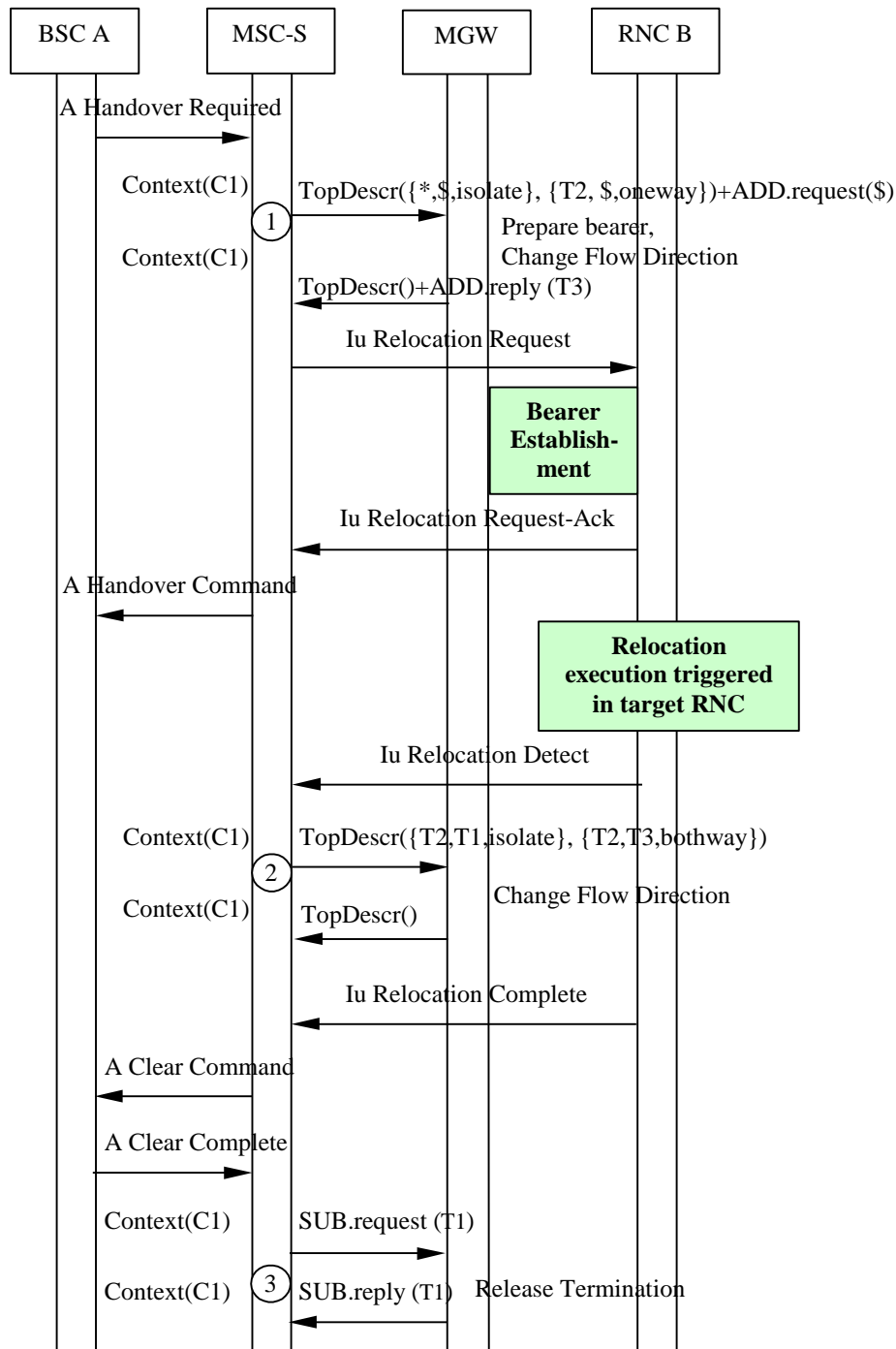


Figure 8.14: Intra-3G\_MSC GSM to UMTS Handover (message sequence chart)

### 8.3.2 Basic Inter-MSC GSM to UMTS Handover

The following handling shall be applied for a call that started as UMTS call. The procedures specified in 3GPP TS 23.009 [8] for "Basic Handover Procedure Requiring a Circuit Connection between MSC-A and 3G\_MSC-B" shall be followed. The following clauses describe the additional requirements for the bearer independent CS core network.

## 8.3.2.1 MSC-A

### 8.3.2.1.1 Handover Required

For Handover towards GERAN Iu mode the GERAN capabilities of the target cell will be indicated to the MSC-A server within the Handover Required message if the target cell provides different capabilities than the current cell. If no information about the GERAN capabilities of the target cell are received within this message, the MSC-A server shall assume that the GERAN target cell will provide the same capabilities as the current cell (for details see [29]).

The MSC-A server shall indicate to the MSC-B server the GERAN capabilities of the target cell, if available, with the MAP Prepare Handover request. For speech calls, the MSC-A server shall additionally indicate to the MSC-B server the selected codec, the list of supported codecs, and the currently used codec.

### 8.3.2.1.2 Bearer establishment between MGW-A and MGW-B

The handling of the bearer establishment between MGW-A and MGW-B is as described for a Basic Mobile Originating Call, using either forward or backward bearer establishment. For speech calls, the MSC-A server shall provide the MGW-A with the speech coding information for the bearer. For non-speech calls the MSC-A server shall provide MGW-A with the same PLMN Bearer Capabilities [4] as were provided at the last access bearer assignment. The MSC-A server also uses the Change Flow Direction procedure to request MGW-A to set the Handover Device to initial state (bullet 3 in figure 8.16/1).

### 8.3.2.1.3 Handover Command/Handover Detect

When the MSC-A server sends the Handover Command message or alternatively if it receives the Handover Detect message, the MSC-A server uses the Change Flow Direction procedure to request MGW-A to set the Handover Device to intermediate state (bullet 4 in figure 8.16/2).

### 8.3.2.1.4 Handover Complete

When the MSC-A server receives the Handover Complete message, it releases the A-interface line towards BSC-A and requests MGW-A to set the Handover Device to its final state by removing the bearer termination towards BSC-A, using Release Termination procedure (bullet 5 in figure 8.16/2).

### 8.3.2.1.5 Interworking function

The interworking function used by MGW-A before handover will also be used after handover.

### 8.3.2.1.6 Codec handling

The MGW may include a speech transcoder based upon the speech coding information provided to each bearer termination.

### 8.3.2.1.7 Voice Processing function

Voice processing function(s) provided by MGW-A before handover, may be modified or disabled by MGW-A after handover.

### 8.3.2.1.8 Failure Handling in MSC server

When a procedure between the MSC-A server and MGW-A fails the MSC-A server shall handle the failure as an internal error in accordance with 3GPP TS 23.009 [8] and 3GPP TS 29.010 [23]. If the call establishment towards MSC-B has already started then the call towards MSC-B server shall be cleared as described in clause 7.3. If the original call is to be cleared, then it shall be handled as described in clause 7.3.

## 8.3.2.2 MSC-B

### 8.3.2.2.1 MGW selection

The MSC-B server selects an MGW when it receives Prepare Handover Request message (bullet 1 in figure 8.16).

### 8.3.2.2.2 Bearer establishment towards RNC-B

When the MSC-B server has selected MGW-B it requests MGW-B to provide a binding reference and a bearer address using the Prepare Bearer procedure. For speech calls, the MSC server shall provide the MGW with the speech coding information for the bearer. The MSC-B server sends the Relocation Request message to the RNC-B containing the bearer address and binding reference (bullet 2 in figure 8.16).

For Handover towards GERAN Iu-mode, the MSC-B Server shall select a service according to the Channel Type received with the Handover Request message and the capabilities of the GERAN target cell, if the GERAN classmark was received. For speech calls, the MSC-B server shall additionally take into account the selected codec, the list of supported codecs and the currently used codec received with MAP Prepare Handover request. The list of permitted speech versions received with the Channel Type in the Handover Request message is applicable to GERAN A/Gb mode only.

The MSC-B server shall indicate to the GERAN the selected service within the RANAP RELOCATION REQUEST message and shall set the RAB parameters within the RANAP RELOCATION REQUEST message according to the selected service. The MSC server shall not set codec information in the NAS Synchronisation Indicator (see [4]). Instead it shall set codec information in the GERAN BSC container..

For speech calls, the MSC-B server shall report the chosen codec and codec modes back to the MSC-A server with MAP Prepare Handover response.

### 8.3.2.2.3 Bearer establishment between MGW-A and MGW-B

The handling of the bearer establishment is as described at Basic Mobile Terminating Call, using either forward or backward bearer establishment.

### 8.3.2.2.4 Codec handling

The MGW may include a speech transcoder based upon the speech coding information provided to each bearer termination.

### 8.3.2.2.5 Voice Processing function

Voice processing function(s) provided by MGW-A before handover, may be continued or modified by MGW-B after handover.

### 8.3.2.2.6 Failure Handling in MSC server

When a procedure between the MSC-B server and MGW-B fails the MSC-B server shall handle the failure as an internal error in accordance with 3GPP TS 23.009 [8] and 3GPP TS 29.010 [23]. If MGW-B resources have already been seized at the target access side then the resources shall be released using the Release Termination procedure. The call from MSC-A server shall be released as described at clause 7.1.

8.3.2.2.7 Example

Figure 8.15 shows the network model for the Basic Inter-MSC GSM to UMTS Handover. The "squared" line represents the call control signalling. The "dotted" line represents the bearer control signalling (not applicable in case of GSM access) and the bearer. In MGW-A the bearer termination T1 is used for the bearer towards BSC-A, bearer termination T3 is used for the bearer towards MGW-B, and the bearer termination T2 is used for the bearer towards the succeeding/preceding MGW. In MGW-B the bearer termination T4 is used for the bearer towards RNC-B, bearer termination T5 is used for the bearer towards MGW-A.

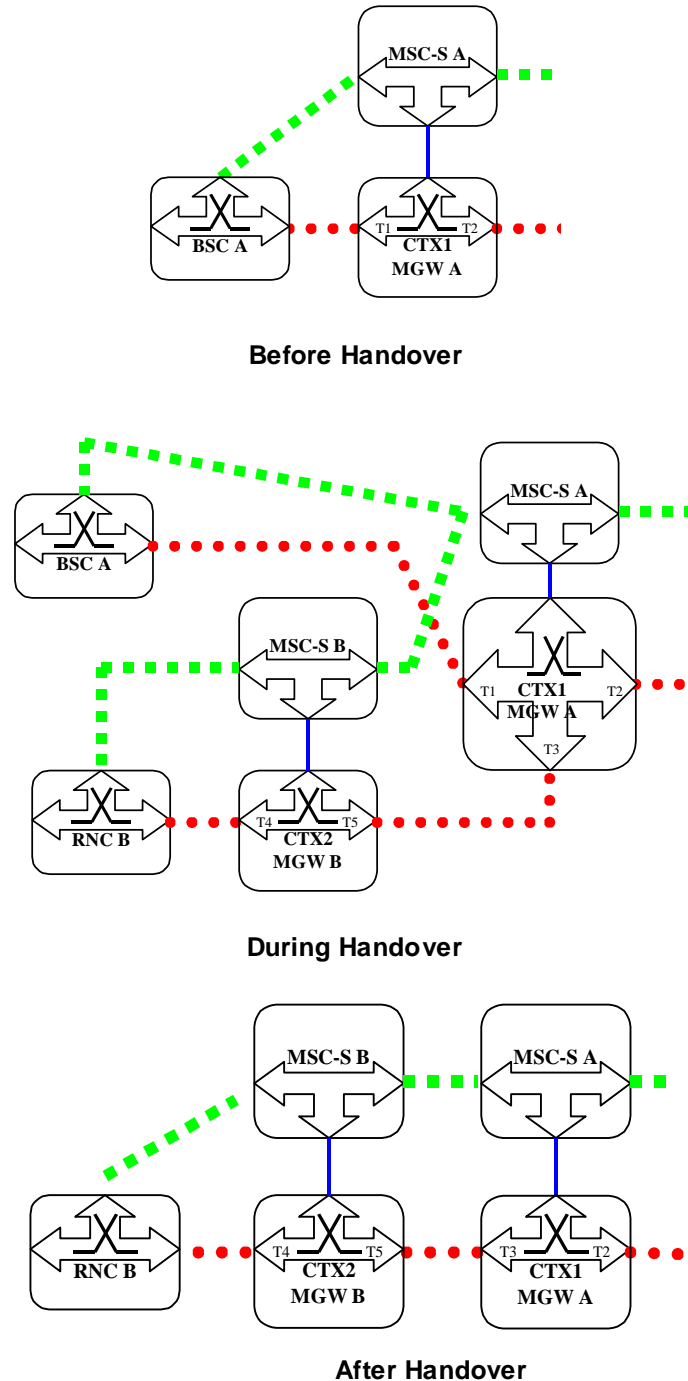


Figure 8.15: Basic Inter-MSC GSM to UMTS Handover (network model)

Figure 8.16 shows the message sequence example for the Basic Inter-MSC GSM to UMTS Handover. It is assumed that the Handover Device is located in the MGW (MGW -A) selected for the call establishment by the MSC server (MSC-A server) which controls the call and the mobility management.

In the example the MSC-B server requests MGW-B to seize RNC-B side bearer termination. The call is established between MSC-A server and MSC-B server, and the bearer is established between MGW-A and MGW-B. When the relocation is detected in RNC-B the MSC-A server requests to change the flow directions between the terminations within the context in MGW-A. When MSC-A server receives Handover Complete indication from MSC-B server it releases the A-interface line towards the BSC-A. Finally MSC-A server requests MGW-A to remove BSC-A side bearer termination.

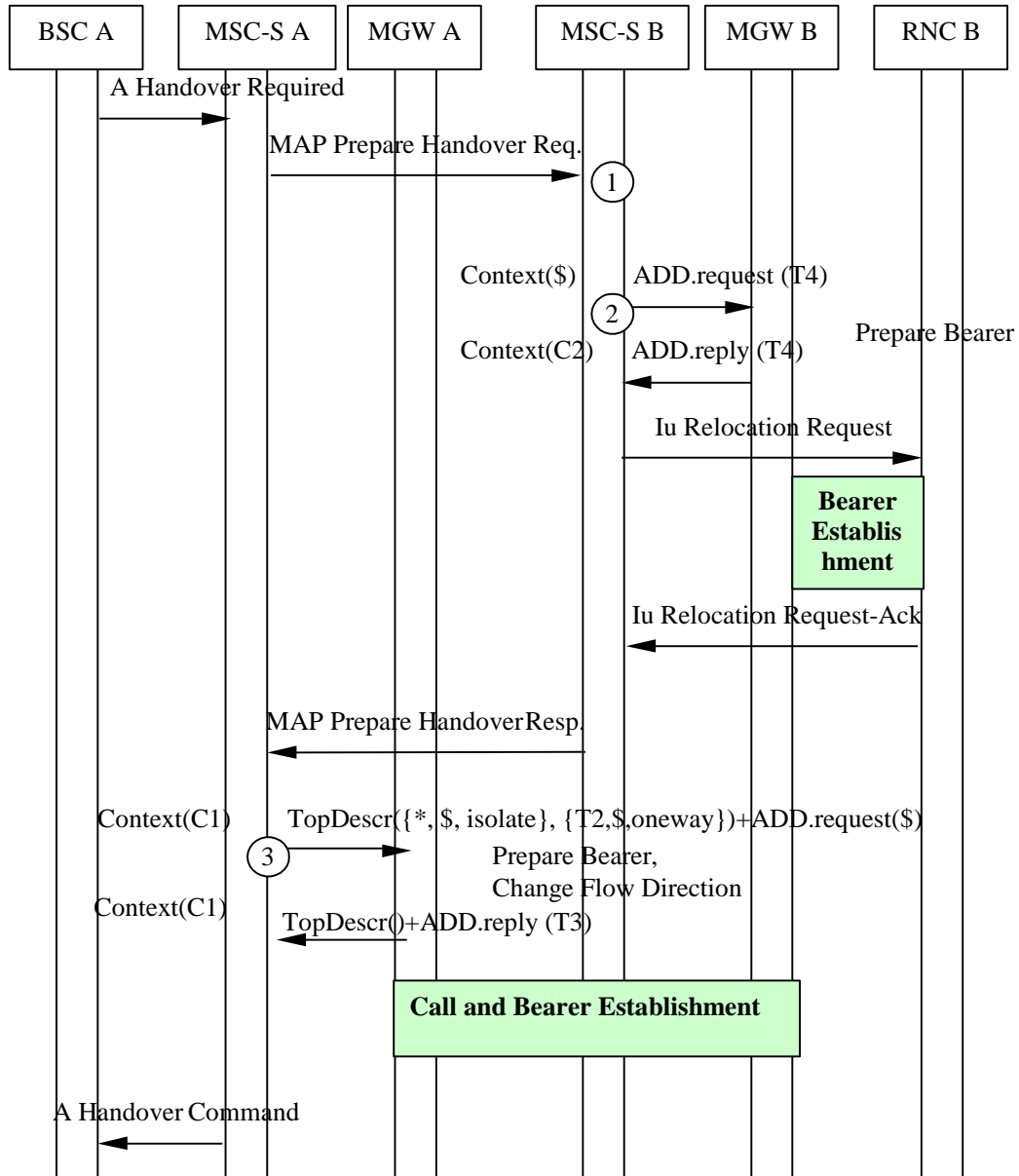


Figure 8.16/1: Basic Inter-MSC GSM to UMTS Handover (message sequence chart)

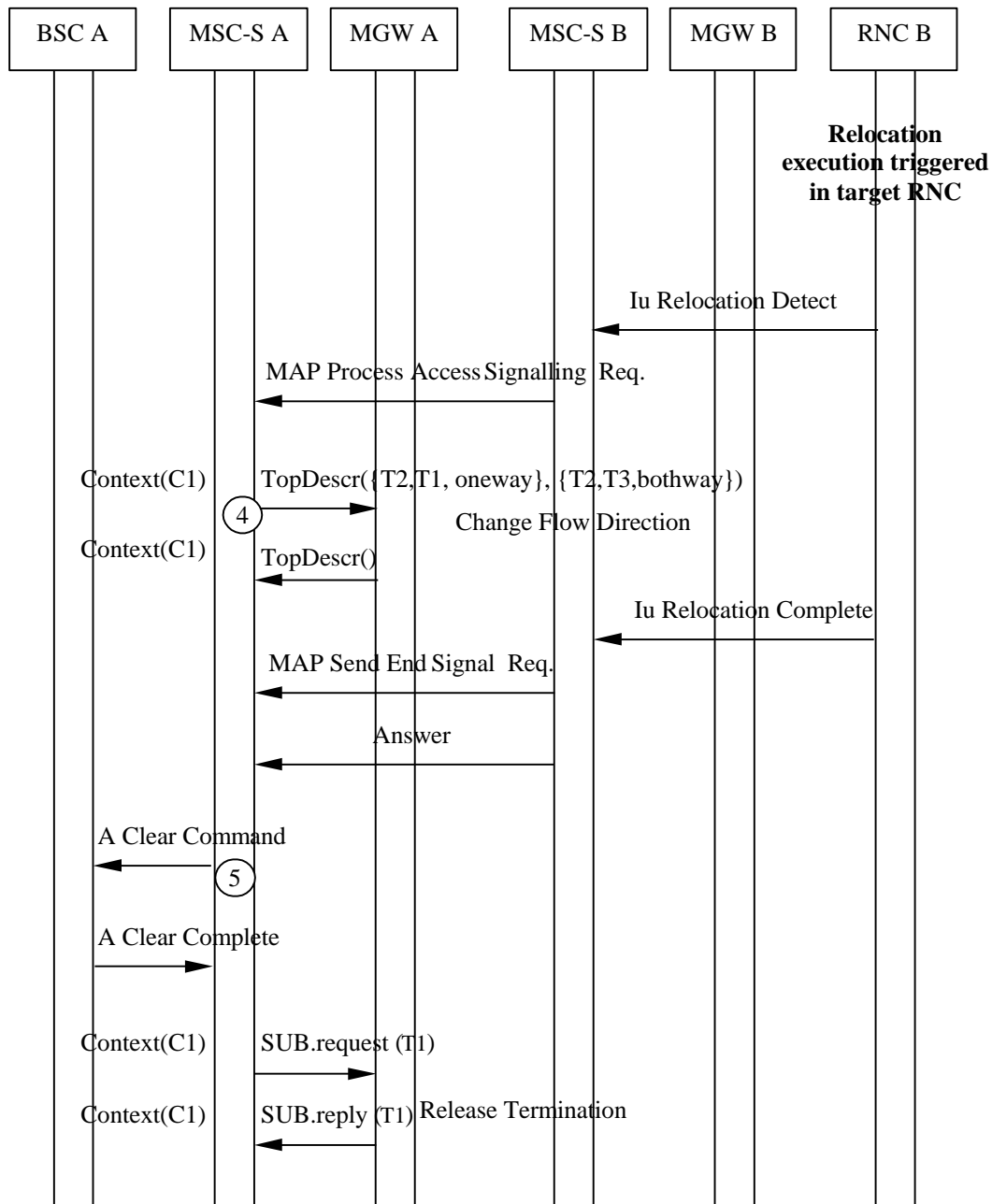


Figure 8.16/2: Basic Inter-MSC GSM to UMTS Handover (message sequence chart)

### 8.3.3 Subsequent Inter-MSC GSM to UMTS Handover back to the Anchor MSC

The following handling shall be applied for a call that started as UMTS call. The procedures specified in 3GPP TS 23.009 [8] for "Subsequent Inter-MSC GSM to UMTS Handover back to the Anchor MSC" shall be followed. The following clauses describe the additional requirements for the bearer independent CS core network.

#### 8.3.3.1 MSC-A

##### 8.3.3.1.1 Handover Request

When the MSC-A server receives a MAP Prepare Subsequent Handover request containing a Handover Request message, it requests the MGW-A to provide a binding reference and a bearer address using the Prepare Bearer procedure. For speech calls, the MSC-A server shall provide the MGW-A with the speech coding information for the bearer. For non-speech calls the MSC-A server shall provide MGW-A with the same PLMN Bearer Capability [4] as

was provided at the last channel assignment. The MSC-A server uses the Change Flow Direction Procedure to request the MGW-A to set the Handover Device to initial state. The MSC-A server sends the Relocation Request message to the RNC-B containing the bearer address and binding reference (bullet 1 in figure 8.18/1).

For Handover towards GERAN Iu-mode, the MSC-A Server shall select a service according to the Channel Type received with the Handover Request message and the capabilities of the GERAN target cell, if the GERAN classmark was received. For speech calls, the MSC-A server shall additionally take into account the selected codec and the currently used codec received with MAP Prepare Subsequent Handover request, and the list of supported codecs.

The MSC-A server shall indicate to the GERAN the selected service within the RANAP RELOCATION REQUEST message and shall set the RAB parameters within the RANAP RELOCATION REQUEST message according to the selected service. The MSC server shall not set codec information in the NAS Synchronisation Indicator (see [4]). Instead it shall set codec information in the GERAN BSC container.

#### 8.3.3.1.2 Handover Command/Relocation Detect

When the MSC-A server sends the MAP Prepare Subsequent Handover response message or alternatively if it receives a Relocation Detect message, the MSC-A server uses the Change Flow Direction procedure to requests the MGW -A to set the Handover Device to intermediate state (bullet 2 in figure 8.18/2).

#### 8.3.3.1.3 Relocation Complete

When the MSC-A server receives a Relocation Complete message, it informs the MSC-B server about reception of this message. MSC-A server then initiates call clearing towards the MSC-B server as described in clause 7.3.

#### 8.3.3.1.4 Interworking function

The interworking function used by MGW -A before handover will also be used after handover.

#### 8.3.3.1.5 Codec handling

The MGW may include a speech transcoder based upon the speech coding information provided to each bearer termination.

#### 8.3.3.1.6 Voice Processing function

Voice processing function(s) provided by MGW -A and MGW-B before handover, may be continued or modified by MGW -A after handover.

#### 8.3.3.1.7 Failure Handling in MSC server

When a procedure between the MSC-A server and the MGW fails the MSC-A server shall handle the failure as an internal error in accordance with 3GPP TS 23.009 [8] and 3GPP TS 29.010 [23]. If MGW resources have been already seized at the target access side then the resources shall be released using the Release Termination procedure. If the call is to be cleared, then it shall be handled as described in clause 7.3.

### 8.3.3.2 MSC-B / MGW-B

#### 8.3.3.2.1 Handover Required

For Handover towards GERAN Iu mode the GERAN capabilities of the target cell will be indicated to the MSC-B server within the Handover Required message if the target cell provides different capabilities than the current cell. If no information about the GERAN capabilities of the target cell are received within this message, the MSC-B server shall assume that the GERAN target cell will provide the same capabilities as the current cell (for details see [29]).

The MSC-B server shall indicate to the MSC-A server the GERAN capabilities of the target cell, if available, with the MAP Prepare Subsequent Handover request. For speech calls, the MSC-B server shall additionally indicate to the MSC-A server the selected codec and the currently used codec.



8.3.3.2.2 Handover Complete

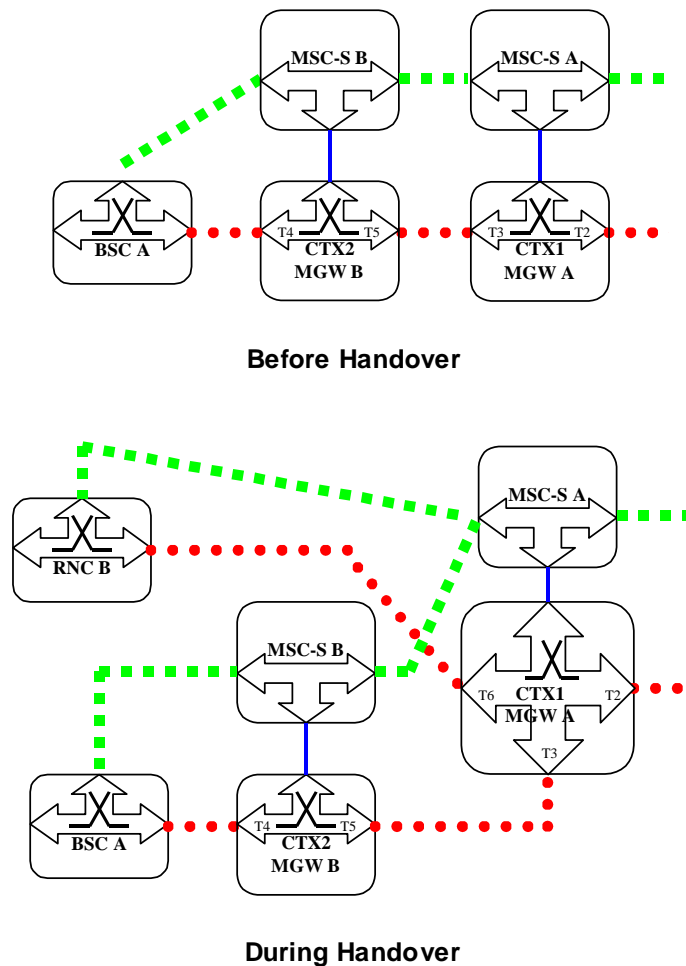
When the MSC-B server receives the Handover Complete message, it releases the A-interface line towards the BSC-A and requests the MGW-B to remove the bearer termination towards the BSC-A using the Release Termination procedure (bullet 3 in figure 8.18/2).

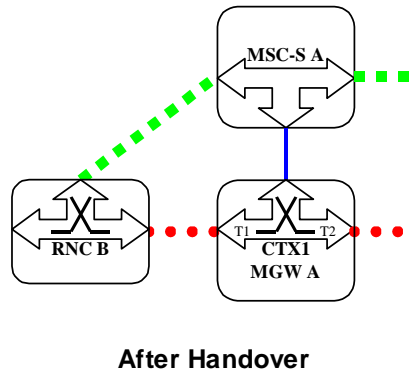
8.3.3.2.3 Release of bearer towards MGW-A

When the MSC-B server receives a call clearing indication from the MSC-A server, the MSC-B server handles it as described in subclause 7.2.

8.3.3.2.4 Example

Figure 8.17 shows the network model for Subsequent Inter-MSC GSM to UMTS Handover back to the Anchor MSC. The "squared" line represents the call control signalling. The "dotted" line represents the bearer control signalling (not applicable in case of GSM access) and the bearer. In the MGW the bearer termination T1 is used for the bearer towards RNC-B, the bearer termination T3 is used for the bearer towards MSC-A server, and the bearer termination T2 is used for the bearer towards the succeeding/preceding MGW. In MGW-B the bearer termination T4 is used for the bearer towards BSC-A, bearer termination T5 is used for the bearer towards MGW-A.

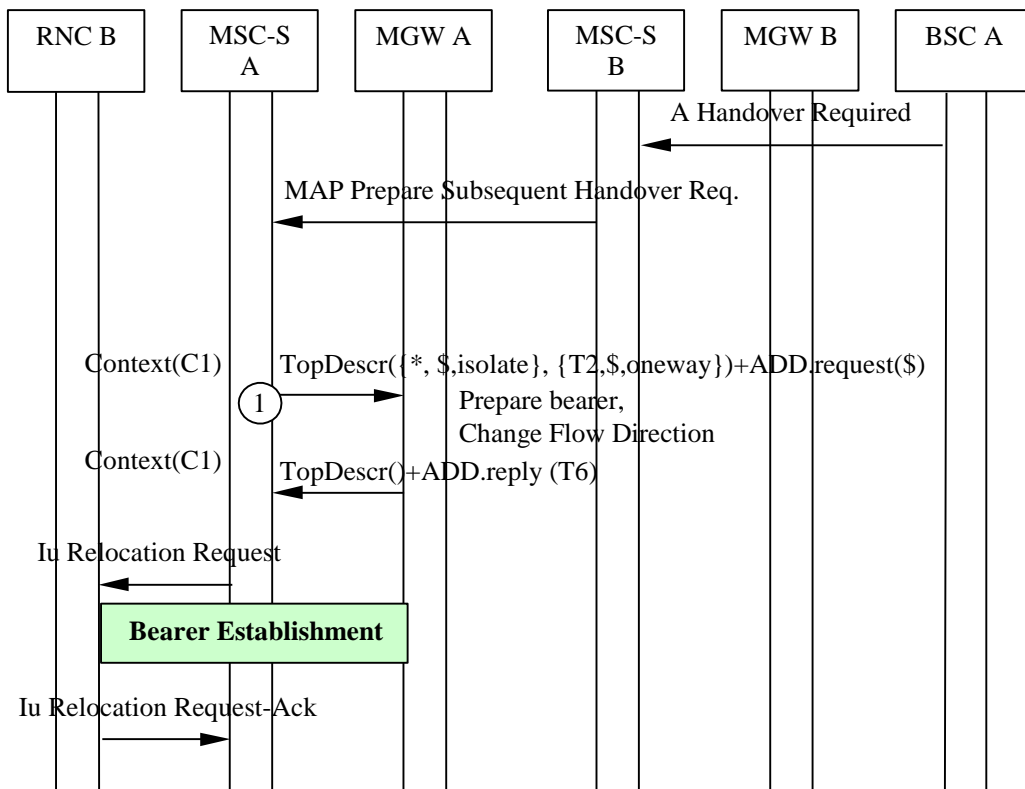




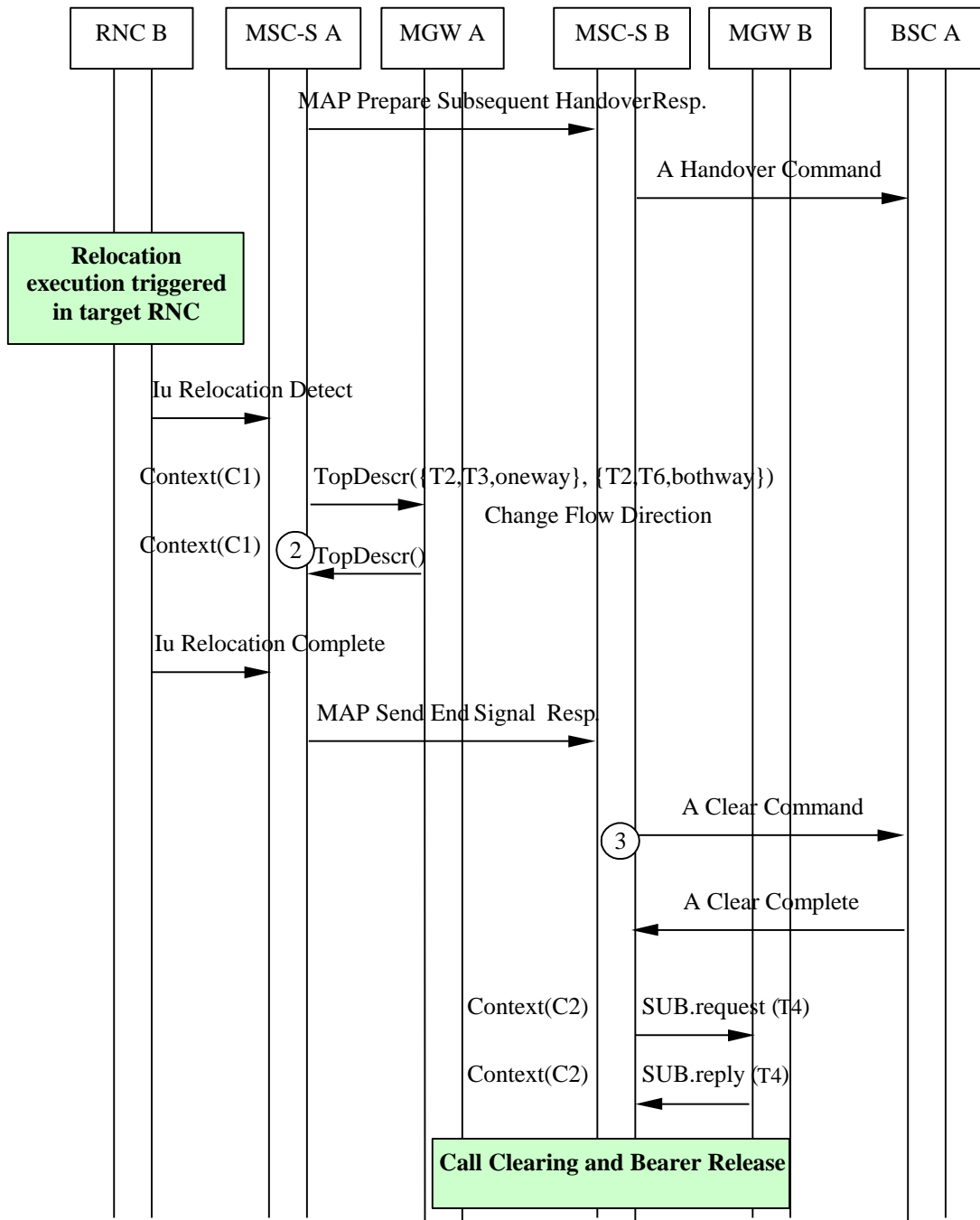
**Figure 8.17: Subsequent Inter-MSC GSM to UMTS Handover back to the Anchor MSC (network model)**

Figure 8.18 shows the message sequence example for the Subsequent Inter-MSC GSM to UMTS Handover back to the Anchor MSC. It is assumed that the Handover Device is located in the MGW (MGW -A) selected for the call establishment by the MSC server (MSC-A server) which controls the call and the mobility management.

In the example the MSC-A server requests MGW-A to seize RNC-B side bearer termination with specific flow directions. When the relocation is detected in RNC-B the MSC-A server requests to change the flow directions between the terminations within the context in MGW -A. When MSC-A server receives Handover Complete indication from RNC-B it transfers this indication to MSC-B server. MSC-B server releases the A-interface line towards the BSC-A. MSC-A server initiates call clearing towards MSC-B server.



**Figure 8.18/1: Subsequent Inter-MSC GSM to UMTS Handover back to the Anchor MSC (message sequence chart)**



**Figure 8.18/2: Subsequent Inter-MSC GSM to UMTS Handover back to the Anchor MSC (message sequence chart)**

### 8.3.4 Subsequent Inter-MSC GSM to UMTS Handover to a third MSC

The GSM to UMTS handover to a third MSC server (from MSC-B server to MSC-B server) is the combination of the two previous inter-MSC handover cases:

- for MSC-B server a subsequent GSM to UMTS handover from MSC-B server back to MSC-A server as described in clause 8.3.3; and
- for MSC-B server a basic GSM to UMTS handover from MSC-A server to MSC-B server as described in clause 8.3.2.

MSC-A server implements the corresponding parts of each handover case; i.e. access handling in MSC-A server is not included.

### 8.3.5 GSM to UMTS Handover with Iu on IP

If IuCS on IP is supported by the MSC server, the Core Network side procedures described in clauses 8.3.1, 8.3.2, 8.3.3, 8.3.4 shall apply. For the access bearer termination, the exchange of IP addresses via call control procedures is described in this clause.

Before the MSC server starts the access bearer assignment, the MSC server requests the MGW to prepare for the access bearer using the Prepare\_IP\_Transport procedure. The MSC server requests the MGW to provide an IP Transport address and UDP Port and provides the MGW with the bearer characteristics. For speech calls, the MSC server shall provide the MGW with the speech coding information and conditionally GTT related information in accordance with 3GPP TS 23.226 [28] for the bearer. For a non-speech call the MSC server also provides the MGW with a PLMN Bearer Capability [4]. After the MGW has replied with the IP address and UDP Port the MSC server requests access bearer assignment using the provided IP address and UDP Port in accordance with 3GPP TS 25.413 [26]. The IP addresses and UDP Ports of the MGW and the RNC are exchanged via the RANAP procedures. If the bearer transport is IP and IuUP mode is Transparent, when the MSC receives the RANAP Iu Relocation Request response, it shall send the RNC IP address and UDP Port to the MGW Access bearer termination using the Modify\_IP\_Transport\_Address procedure.

If the bearer transport is IP and IuUP mode is Support, the MGW shall use the source IP address and UDP Port of the IuUP Init packet received from the radio access network as the destination address for subsequent downlink packets.

The sequence is shown in figure 8.3.5/1.

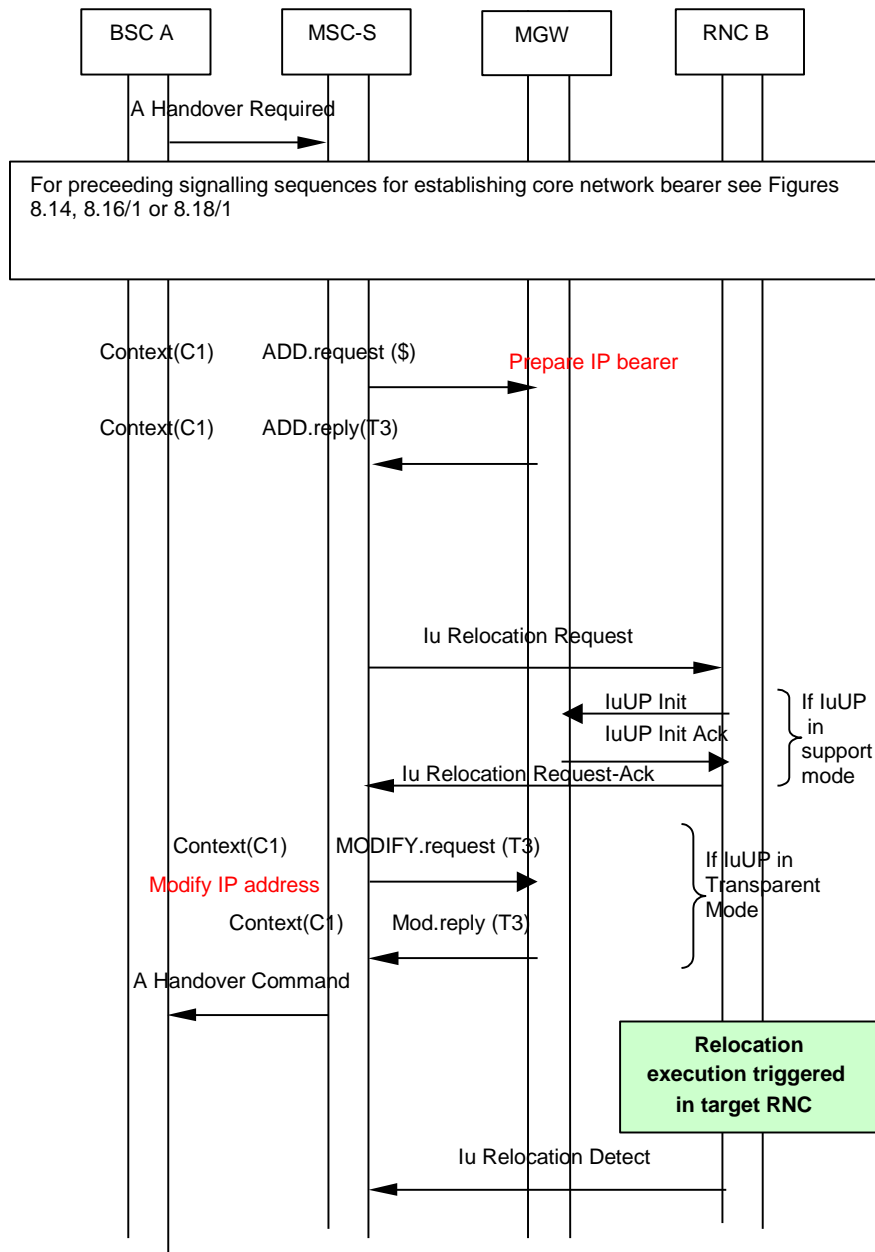


Figure 8.3.5/1 GSM to UMTS Handover with Iu on IP

## 8.4 GSM to GSM

### 8.4.1 Intra-MSC Inter-BSS GSM to GSM Handover

The procedures specified in 3GPP TS 23.009 [8] for "Intra-MSC Handover" shall be followed. The following clauses describe the additional requirements for the bearer independent CS core network.

#### 8.4.1.1 Handover Required

When the MSC server receives a Handover Required message, it requests the MGW to seize a TDM circuit, using the Reserve Circuit procedure. For non-speech calls the MSC server shall provide the MGW with the GSM Channel coding properties and the same PLMN Bearer Capability [4] as was provided at the last access bearer assignment. The MSC server uses the Change Flow Direction procedure to request the MGW to set the Handover Device to initial state. The MSC server sends the Handover Request message to the BSC-B containing the CIC (bullet 1 in figure 8.20/1).

#### 8.4.1.2 Handover Request Acknowledge

For non-speech calls after receiving Handover Request Acknowledge message if the assigned GSM Channel coding properties differ from the previously provided ones the MSC server provides the MGW-A with the assigned GSM Channel coding properties using the Modify Bearer Characteristics procedure (bullet 2 in figure 8.20/1).

#### 8.4.1.3 Handover Command/Handover Detect

When the MSC server sends the Handover Command message or alternatively if it receives the Handover Detect message, the MSC server uses the Change Flow Direction procedure to request the MGW to set the Handover Device to intermediate state (bullet 3 in figure 8.20/1).

#### 8.4.1.4 Handover Complete

When the MSC server receives the Handover Complete message, it releases the A-interface line towards BSC-A. The MSC server also requests the MGW to set the Handover Device to its final state by removing the bearer termination towards the BSC-A, using the Release Termination procedure (bullet 4 in figure 8.20/2).

#### 8.4.1.5 Interworking function

The interworking function used by the MGW before handover will also be used after handover.

#### 8.4.1.6 Voice Processing function

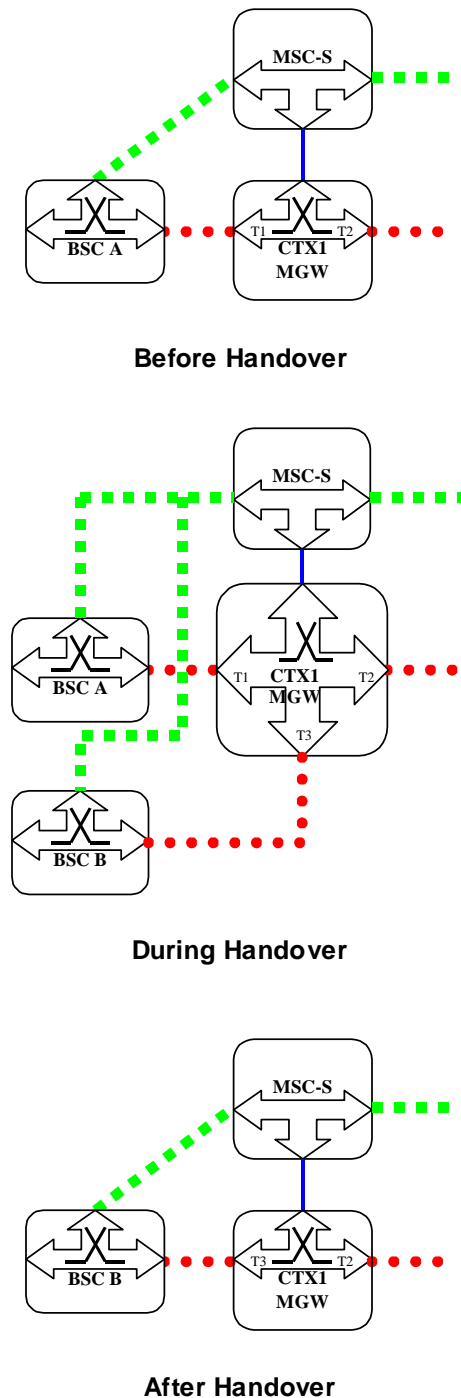
After handover, the MGW may continue or modify voice processing function(s) provided to each bearer termination.

#### 8.4.1.7 Failure Handling in MSC server

When a procedure between the MSC server and the MGW fails the MSC server shall handle the failure as an internal error in accordance with 3GPP TS 23.009 [8] and 3GPP TS 29.010 [23]. If MGW resources have already been seized at the target access side then the resources shall be released using the Release Termination procedure. If the call is to be cleared, then it shall be handled as described in clause 7.3.

### 8.4.1.8 Example

Figure 8.19 shows the network model for the Intra-MSC GSM to GSM Handover. The "squared" line represents the call control signalling. The "dotted" line represents the bearer. The bearer termination T1 is used for the bearer towards BSC-A, bearer termination T3 is used for the bearer towards BSC-B and the bearer termination T2 is used for the bearer towards the succeeding/preceding MGW.



**Figure 8.19: Intra-MSC GSM to GSM Handover (network model)**

Figure 8.20 shows the message sequence example for the Intra-MSC GSM to GSM Handover. It is assumed that the Handover Device is located in the MGW selected for the call establishment by the MSC server, which controls the call and the mobility management.

In the example the MSC server requests seizure of BSC-B side bearer termination with specific flow directions. The MSC server starts handover execution by sending Handover Request towards BSC-B. When the handover is detected in BSC-B the MSC server requests to change the flow directions between the terminations within the context. When MSC server receives Handover Complete indication from BSC-B it releases the A-interface line towards the BSC-A. Finally the MSC server requests the MGW to release BSC-A side bearer termination.

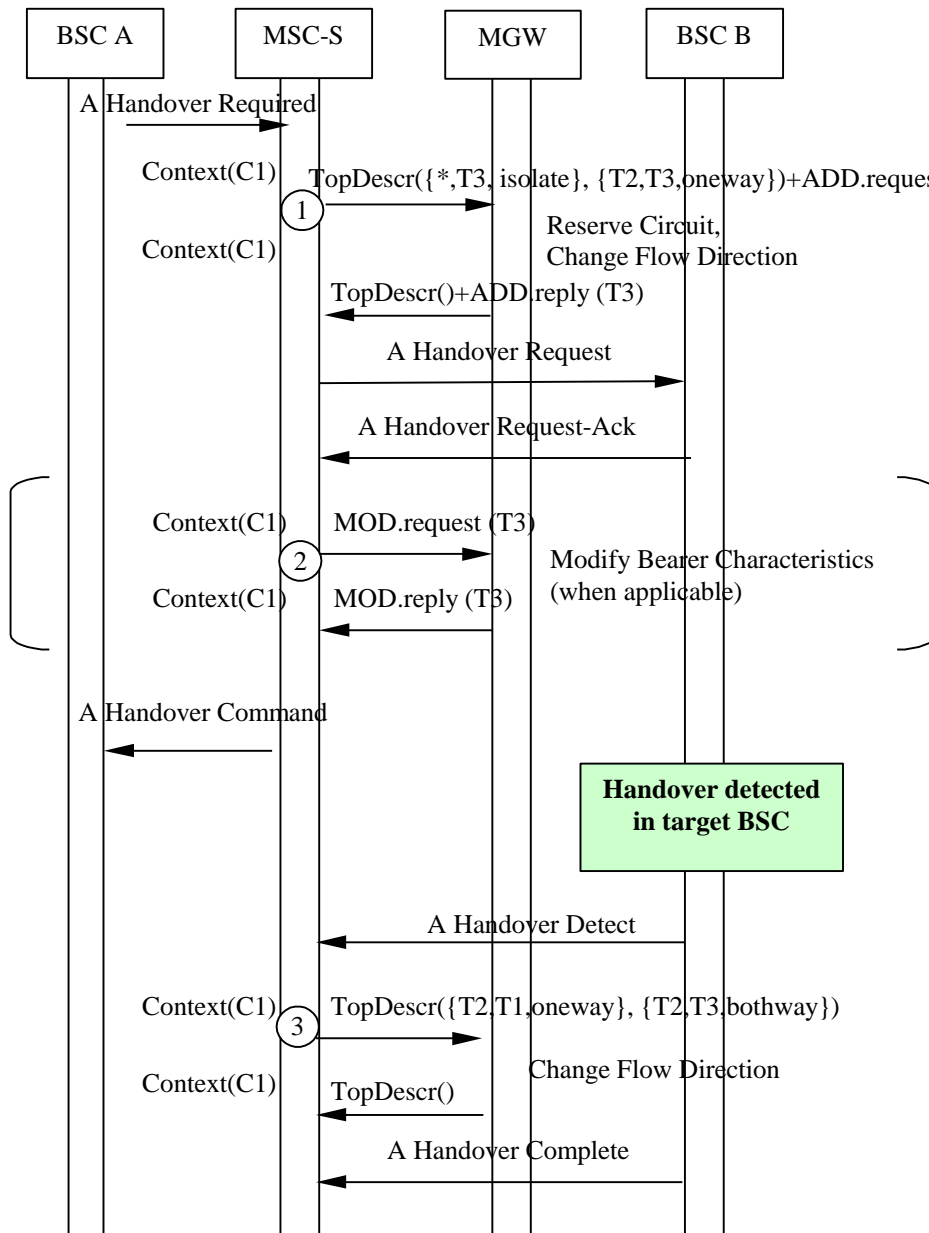


Figure 8.20/1: Intra-MSC GSM to GSM Handover (message sequence chart)



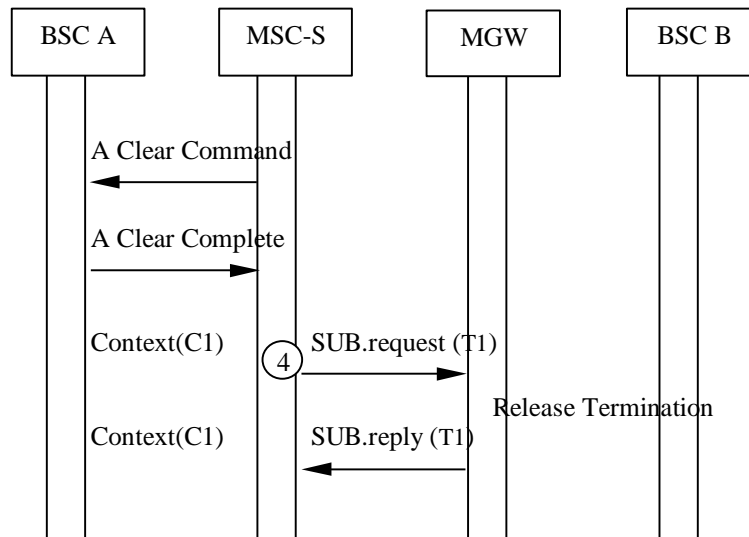


Figure 8.20/2: Intra-MSC GSM to GSM Handover (message sequence chart)

### 8.4.1.9 Intra-MSC GSM to GSM Handover for A interface over IP

When the MSC server receives the BSSAP Handover Required message, it requests the MGW to reserve an RTP bearer termination using the Reserve RTP Connection Point procedure. The MSC server requests the MGW to reserve an IP address and UDP port. The MSC server uses the Change Flow Direction procedure to request the MGW to set the Handover Device to initial state.

The MGW reserves the RTP termination and indicates the IP address and UDP port number to the MSC server. The IP addresses and UDP ports of the MGW is sent to the BSC in the BSSMAP Handover Request message. When the MSC server receives the BSSMAP Handover Request-Ack message, it shall send the BSC IP address and UDP Port number to the MGW using the Configure RTP Connection Point procedure.

The sequence is shown in Figure 8.4.1.9/1.

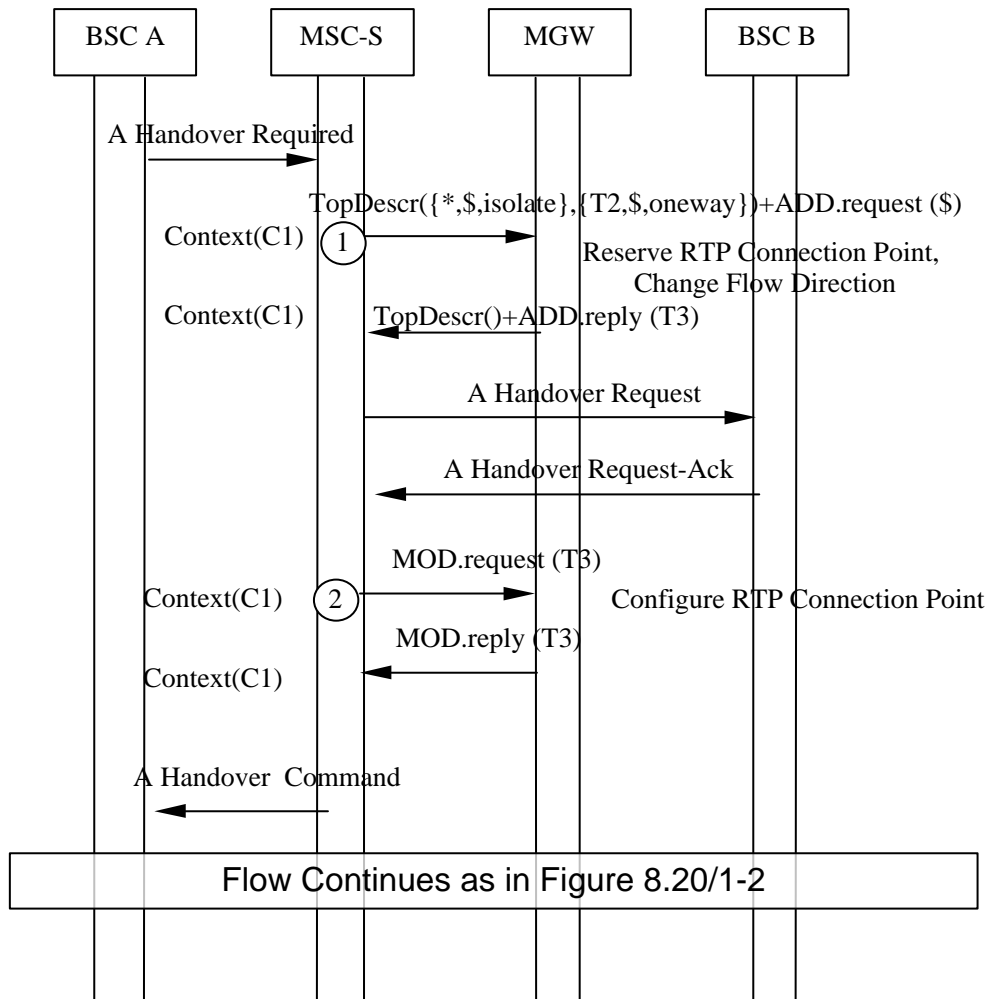


Figure 8.4.1.9/1: Intra-MS-C GSM to GSM Handover for AoIP (message sequence chart)

### 8.4.2 Basic Inter-MS-C GSM to GSM Handover

The procedures specified in 3GPP TS 23.009 [8] for "Basic Handover Procedure Requiring a Circuit Connection between MSC-A and MSC-B" shall be followed. The following clauses describe the additional requirements for the bearer independent CS core network.

#### 8.4.2.1 MSC-A / MGW-A

##### 8.4.2.1.1 Bearer establishment between MGW-A and MGW-B

The handling of the bearer establishment between MGW-A and MGW-B is as described for a Basic Mobile Originating Call, using either forward or backward bearer establishment. For non-speech calls the MSC-A server shall provide MGW-A with the GSM Channel coding properties and the same PLMN Bearer Capability [4] as was provided at the last access bearer assignment. The MSC-A server also uses the Change Flow Direction procedure to request MGW-A to set the Handover Device to initial state (bullet 3 in figure 8.22/2).

##### 8.4.2.1.2 Handover Command/Handover Detect

When the MSC-A server sends the Handover Command message or alternatively if it receives the Handover Detect message, the MSC-A server uses the Change Flow Direction procedure to requests MGW-A to set the Handover Device to intermediate state (bullet 4 in figure 8.22/2).

#### 8.4.2.1.3 Handover Complete

When the MSC-A server receives the Handover Complete message, it releases the A-interface line towards the BSC-A. The MSC-A server also requests MGW-A to set the Handover Device to its final state by removing the bearer termination towards the BSC-A, using the Release Termination procedure (bullet 5 in figure 8.22/2).

#### 8.4.2.1.4 Interworking function

The interworking function used by MGW-A before handover will also be used after handover.

#### 8.4.2.1.5 Voice Processing function

Voice processing function(s) provided by MGW-A before handover, may be modified or disabled by MGW-A after handover.

#### 8.4.2.1.6 Failure Handling in MSC server

When a procedure between the MSC-A server and MGW-A fails the MSC-A server shall handle the failure as an internal error in accordance with 3GPP TS 23.009 [8] and 3GPP TS 29.010 [23]. If call establishment towards the MSC-B server has already started then the call towards MSC-B server shall be cleared as described in clause 7.3. If the original call is to be cleared, then it shall be handled as described in clause 7.3.

### 8.4.2.2 MSC-B / MGW-B

#### 8.4.2.2.1 MGW selection

The MSC-B server selects an MGW when it receives Prepare Handover Request message (bullet 1 in figure 8.22/1).

#### 8.4.2.2.2 Bearer establishment towards BSC-B

When the MSC-B server has selected MGW-B it requests MGW-B to seize a TDM circuit, using the Reserve Circuit procedure. The MSC-B server sends the Handover Request message to the BSC-B containing the CIC (bullet 2 in figure 8.22/1).

#### 8.4.2.2.3 Bearer establishment between MGW-A and MGW-B

The handling of the bearer establishment between MGW-A and MGW-B is as described for a Basic Mobile Terminating Call, using either forward or backward bearer establishment.

#### 8.4.2.2.4 Voice Processing function

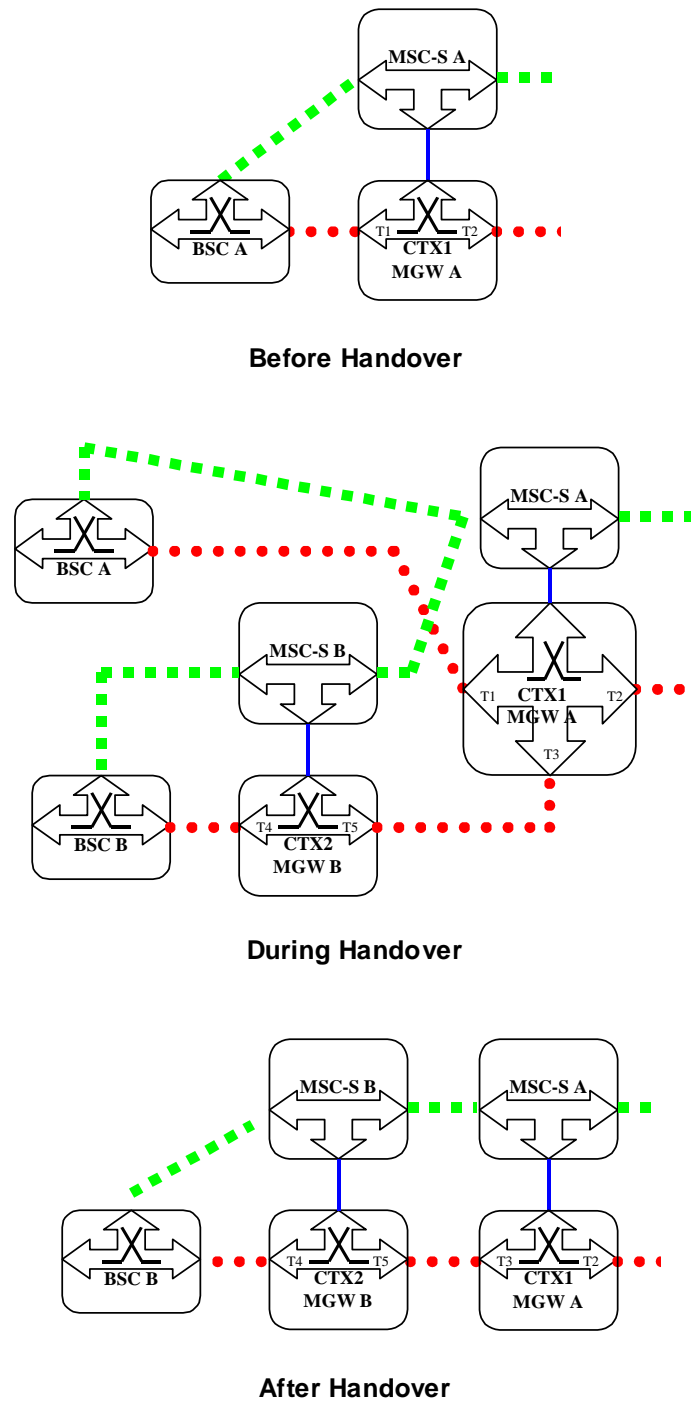
Voice processing function(s) provided by MGW-A before handover, may be continued or modified by MGW-B after handover.

#### 8.4.2.2.5 Failure Handling in MSC server

When a procedure between the MSC-B server and MGW-B fails the MSC-B server shall handle the failure as an internal error in accordance with 3GPP TS 23.009 [8] and 3GPP TS 29.010 [23]. If MGW-B resources have already been seized at the target access side then the resources shall be released using the Release Termination procedure. The call from MSC-A server shall be released as described at clause 7.1.

#### 8.4.2.2.6 Example

Figure 8.21 shows the network model for the Basic Inter-MSC GSM to GSM. The "squared" line represents the call control signalling. The "dotted" line represents the bearer. In MGW-A the bearer termination T1 is used for the bearer towards BSC-A, bearer termination T3 is used for the bearer towards MGW-B, and the bearer termination T2 is used for the bearer towards the succeeding/preceding MGW. In MGW-B the bearer termination T4 is used for the bearer towards BSC-B, bearer termination T5 is used for the bearer towards MGW-A.



**Figure 8.21: Basic Inter-MSC GSM to GSM Handover (network model)**

Figure 8.22 shows the message sequence example for the Basic Inter-MSC GSM to GSM Handover.

It is assumed that the Handover Device is located in the MGW (MGW -A) selected for the call establishment by the MSC server (MSC-A server) which controls the call and the mobility management.

In the example the MSC-B server requests MGW-B to seize BSC-B side bearer termination. The call is established between MSC-A server and MSC-B server, and the bearer is established between MGW-A and MGW-B. When the handover is detected in BSC-B the MSC-A server requests to change the flow directions between the terminations within the context in MGW -A. When MSC-A server receives Relocation Complete indication from MSC-B server it releases the A-interface line towards the BSC-A. Finally MSC-A server requests MGW-A to remove BSC-A side bearer termination.

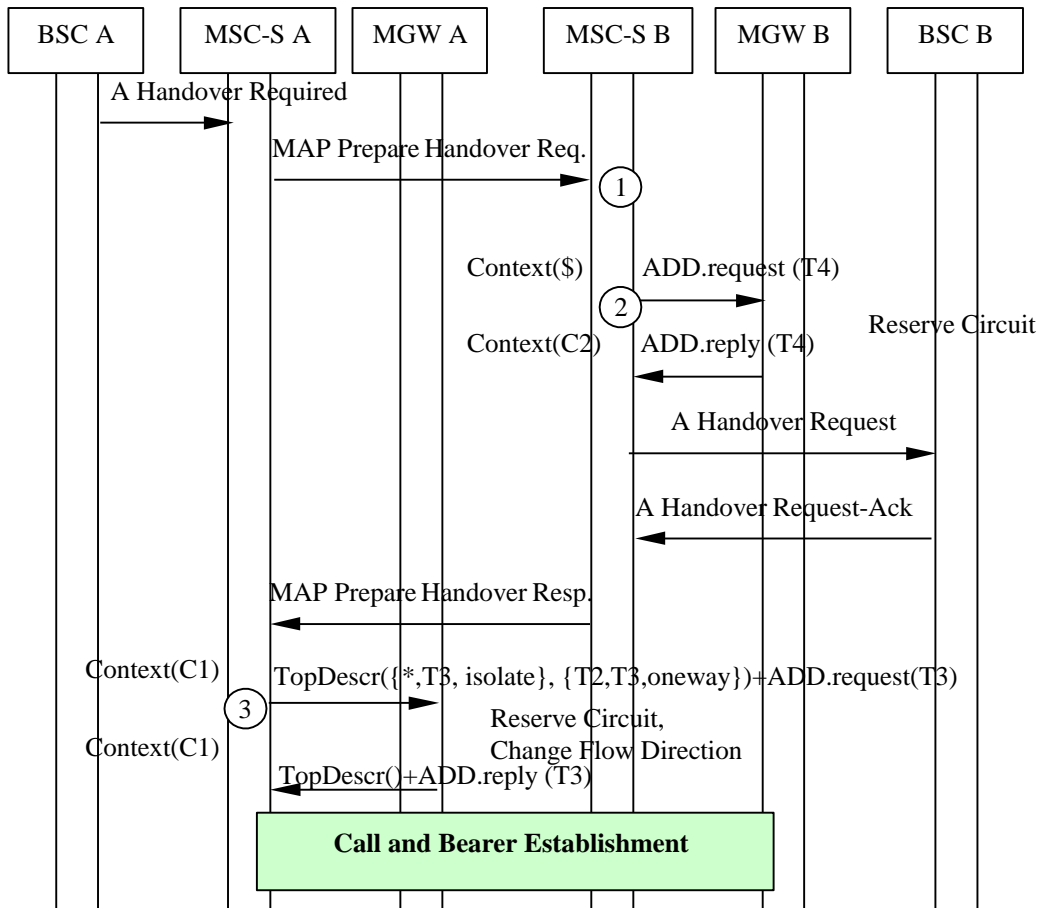


Figure 8.22/1: Basic Inter-MSC GSM to GSM Handover (message sequence chart)

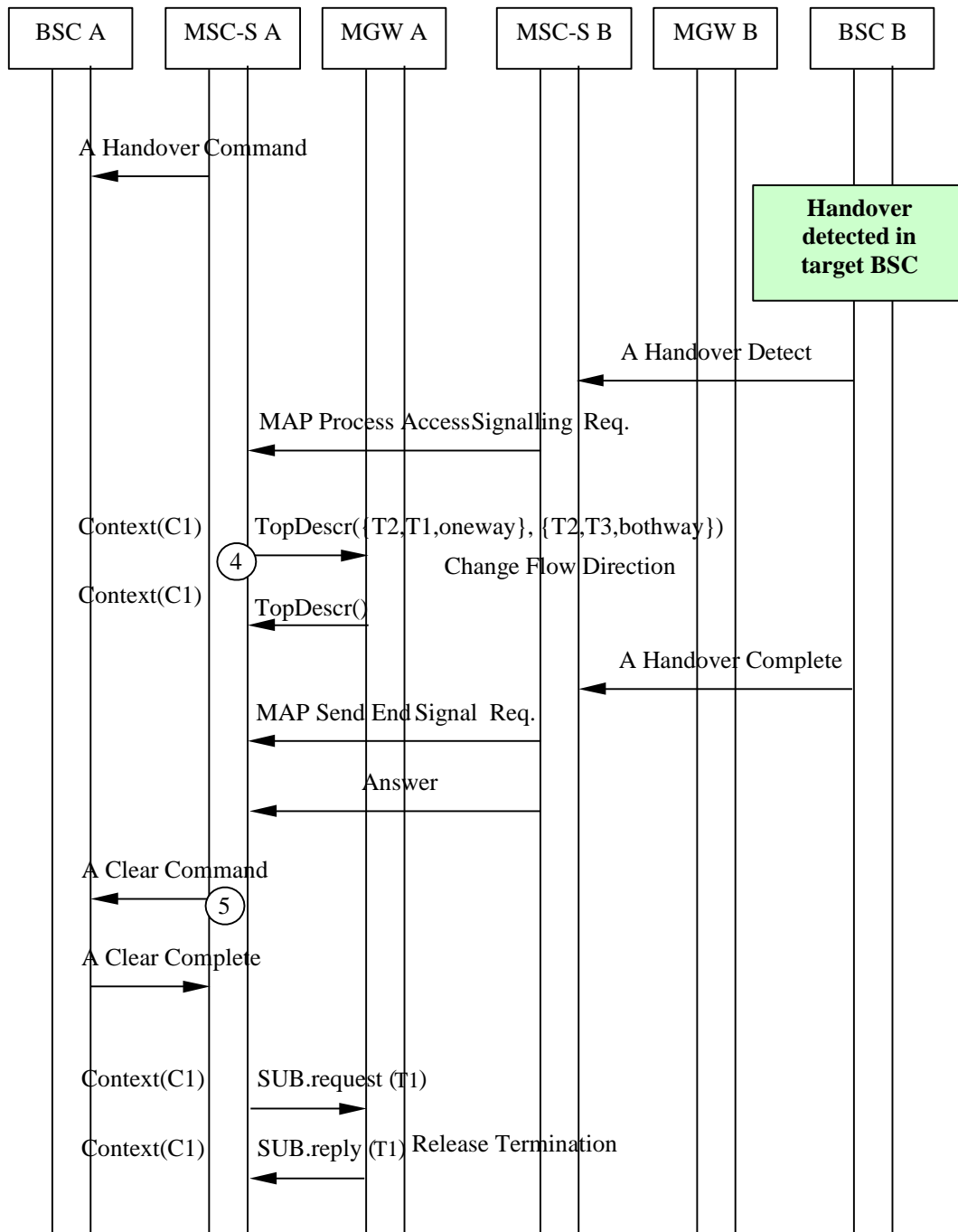


Figure 8.22/2: Basic Inter-MSC GSM to GSM Handover (message sequence chart)

### 8.4.2.3 Basic Inter-MSC GSM to GSM Handover for A Interface over IP

If AoIP is supported by the MSC server, the Core Network side procedures described earlier in 8.4.2 shall apply. For the access side termination, the exchange of IP addresses via call control procedures is described in this clause.

When the MSC-B server receives the MAP Prepare Handover Request., it requests the MGW-B to reserve an RTP bearer termination using the Reserve RTP Connection Point procedure. The MSC-B server requests the MGW-B to reserve an IP address and UDP port.

The MGW-B reserves the RTP termination and indicates the IP address and UDP port number to the MSC-B server. The IP addresses and UDP ports of the MGW is sent to the BSC-B in the BSSMAP Handover Request message. When the MSC-B server receives the BSSMAP Handover Request-Ack message, it shall send the BSC-B IP address and UDP Port number to the MGW-B using the Configure RTP Connection Point procedure.

The sequence is shown in Figure 8.4.2.3/1.

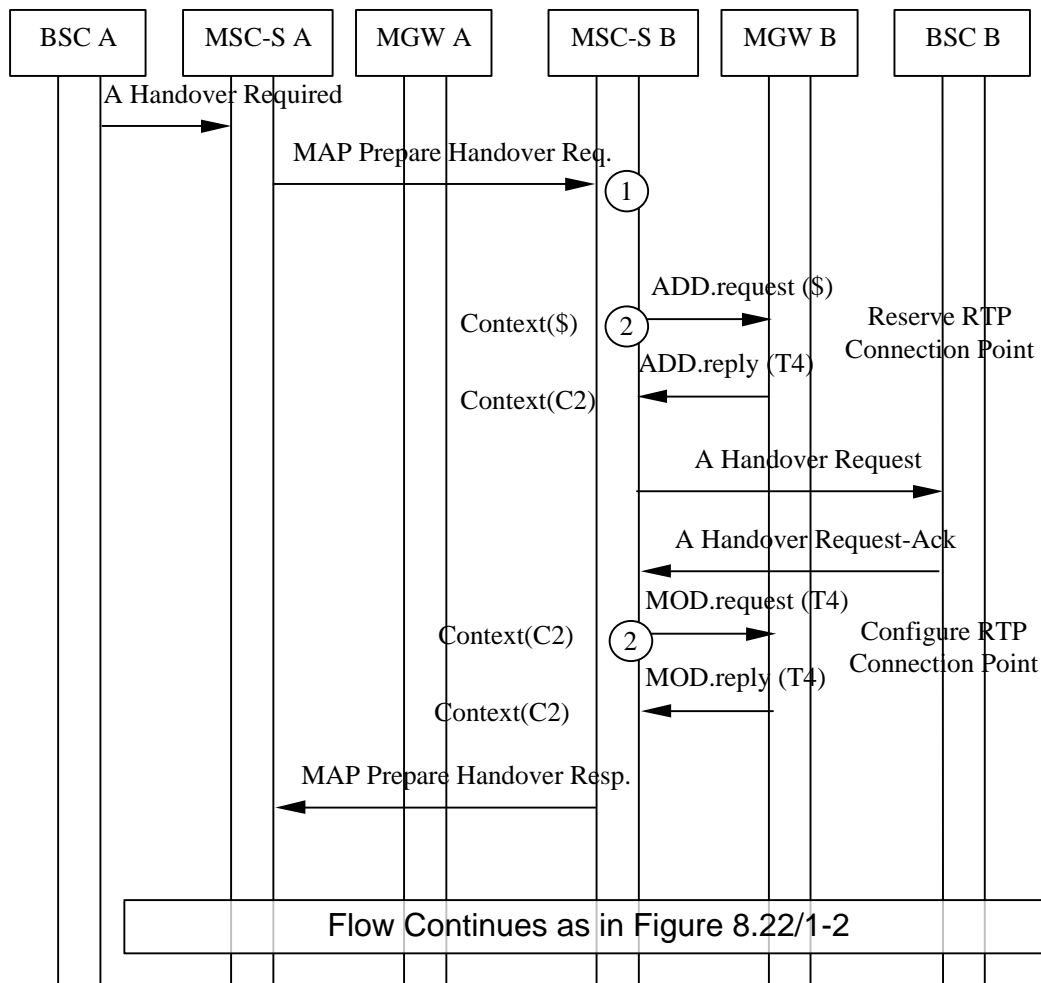


Figure 8.4.2.3/1: Basic Inter-MS-C GSM to GSM Handover for AoIP (message sequence chart)

### 8.4.3 Subsequent Inter-MS-C GSM to GSM Handover back to the Anchor MS-C

The procedures specified in 3GPP TS 23.009 [8] for "Subsequent Handover from MS-C-B to MS-C-A requiring a Circuit Connection between 3G\_MS-C-A and 3G\_MS-C-B" shall be followed. The following clauses describe the additional requirements for the bearer independent CS core network.

#### 8.4.3.1 MS-C-A / MGW-A

When the MS-C-A server receives a MAP Prepare Subsequent Handover request containing a Handover Request message, it requests MGW-A to seize a TDM circuit, using the Reserve Circuit procedure. For non-speech calls the MS-C-A server shall provide MGW-A with the GSM Channel coding properties and the same PLMN Bearer Capability [4] as was provided at the first access bearer assignment. The MS-C-A server uses the Change Flow Direction Procedure to request MGW-A to set the Handover Device to initial state. The MS-C-A server sends the Handover Request message to the BSC-B containing the CIC (bullet 1 in figure 8.24/1).

##### 8.4.3.1.1 Handover Request Acknowledge

For non-speech calls after receiving Handover Request Acknowledge message if the assigned GSM Channel coding properties differ from the previously provided ones the MS-C-A server provides the MGW-A with the assigned GSM Channel coding properties using the Modify Bearer Characteristics procedure (bullet 2 in figure 8.24/2).

8.4.3.1.2 Handover Command/Handover Detect

When the MSC-A server sends the MAP Prepare Subsequent Handover response message or alternatively if it receives the Handover Detect message, the MSC-A server uses the Change Flow Direction procedure to request MGW -A to set the Handover Device to intermediate state (bullet 3 in figure 8.24/2).

8.4.3.1.3 Handover Complete

When the MSC-A server receives the Handover Complete message, it informs the MSC-B server about reception of this message. The MSC-A server then initiates call clearing towards the MSC-B server as described in clause 7.3.

8.4.3.1.4 Interworking function

The interworking function used by MGW -A before handover will also be used after handover.

8.4.3.1.5 Voice Processing function

Voice processing function(s) provided by MGW -A and MGW-B before handover, may be continued or modified by MGW -A after handover.

8.4.3.1.6 Failure Handling in MSC server

When a procedure between the MSC-A server and MGW -A fails the MSC-A server shall handle the failure as an internal error in accordance with 3GPP TS 23.009 [8] and 3GPP TS 29.010 [23]. If MGW -A resources have already been seized at the target access side then the resources shall be released using the Release Termination procedure. If the call is to be cleared, then it shall be handled as described in clause 7.3.

8.4.3.2 MSC-B/MGW-B

8.4.3.2.1 Handover Complete

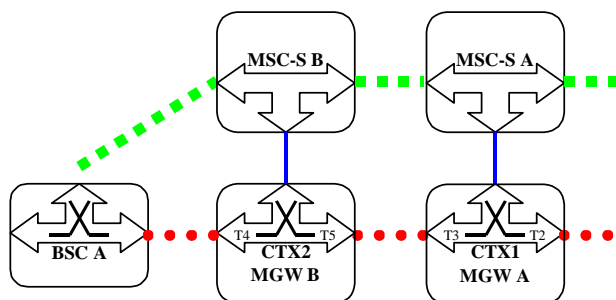
When the MSC-B server receives the Handover Complete message, it releases the A -interface line towards the BSC-A and requests the MGW-B to remove the bearer termination towards the BSC-A using the Release Termination procedure (bullet 4 in figure 8.24/2).

8.4.3.2.2 Release of bearer towards MGW-A

When the MSC-B server receives a call clearing indication from the MSC-A server, the MSC-B server handles it as described in clause 7.2.

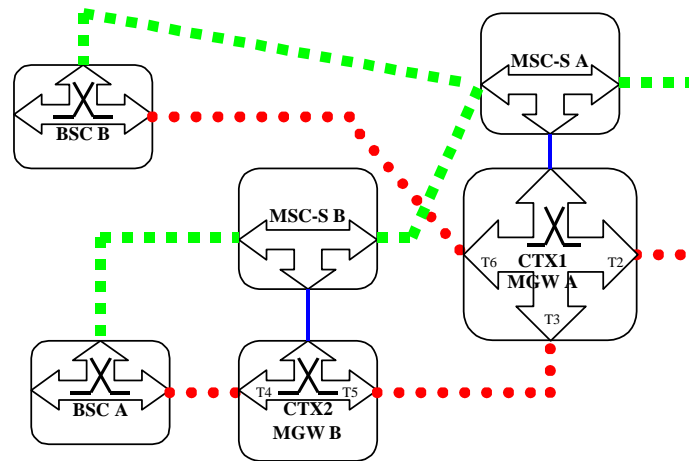
8.4.3.2.3 Example

Figure 8.24 shows the network model for the Subsequent Inter-MSC GSM to GSM Handover back to the Anchor MSC. The "squared" line represents the call control signalling. The "dotted" line represents the bearer. In MGW -A the bearer termination T6 is used for the bearer towards BSC-B, bearer termination T3 is used for the bearer towards MGW -B, and the bearer termination T2 is used for the bearer towards the succeeding/preceding MGW. In MGW -B the bearer termination T4 is used for the bearer towards BSC-A, bearer termination T5 is used for the bearer towards MGW -A.

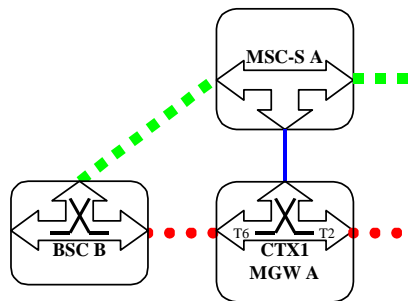


Before Handover





During Handover



After Handover

**Figure 8.23: Subsequent Inter-MSC GSM to GSM Handover back to the Anchor MSC (network model)**

Figure 8.24 shows the message sequence example for the Subsequent Inter-MSC GSM to GSM Handover back to the Anchor MSC. It is assumed that the Handover Device is located in the MGW (MGW -A) selected for the call establishment by the MSC server (MSC-A server) which controls the call and the mobility management.

In the example the MSC-A server requests MGW -A to seize BSC-B side bearer termination with specific flow directions. When the handover is detected in BSC-B the MSC-A server requests to change the flow directions between the terminations within the context in MGW -A. When MSC-A server receives Relocation Complete indication from BSC-B it transfers this indication to MSC-B server. MSC-B server releases the A-interface line towards the BSC-A. MSC-A server initiates call clearing towards MSC-B server.

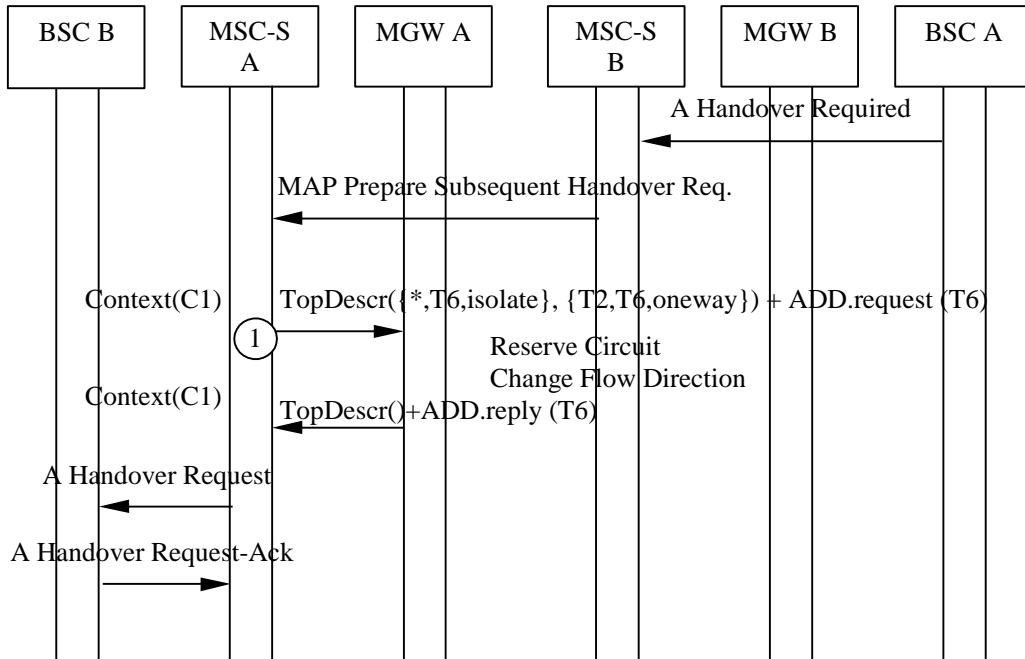


Figure 8.24/1: Subsequent Inter-MSC GSM to GSM Handover back to the Anchor MSC (message sequence chart)

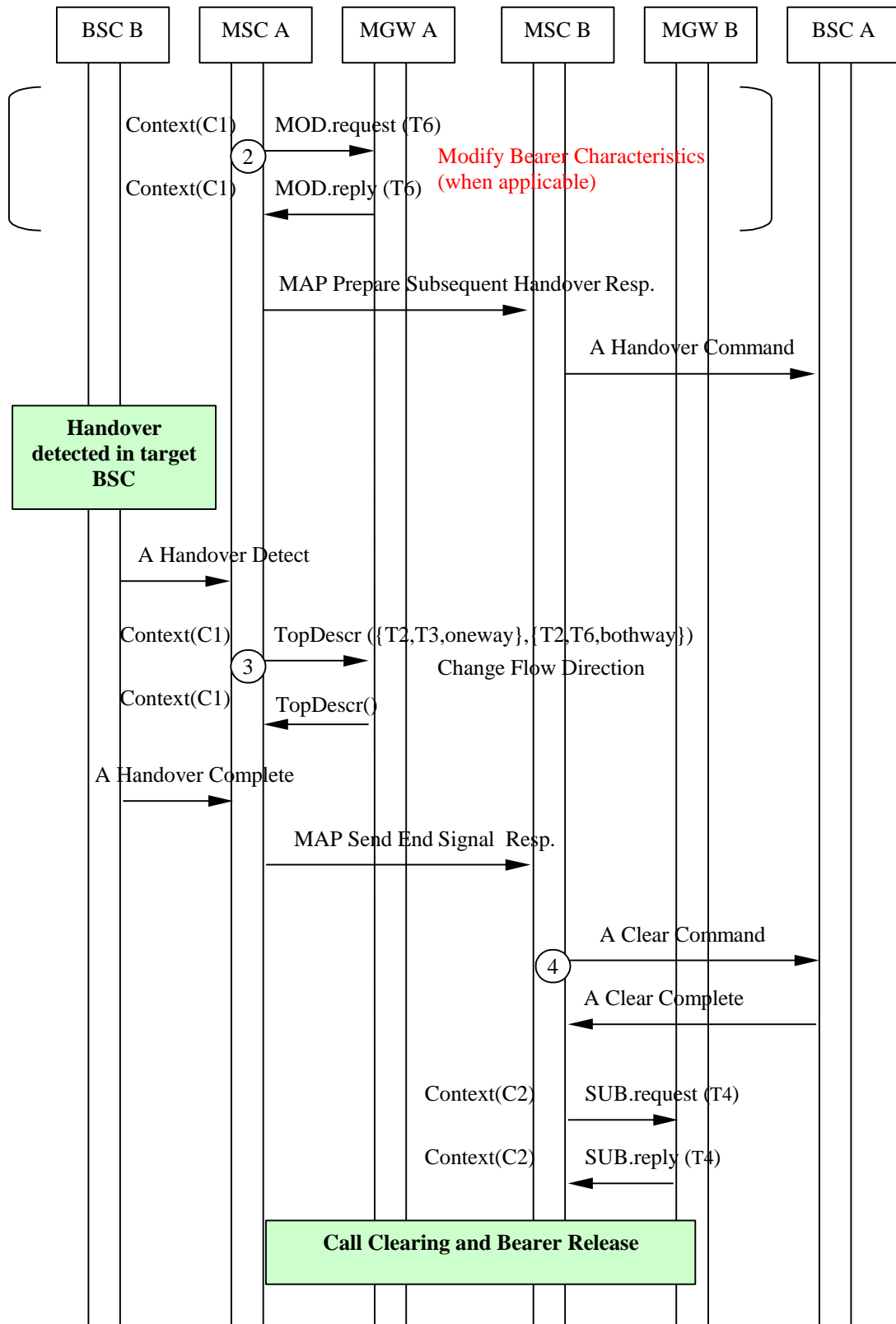


Figure 8.24/2: Subsequent Inter-MSC GSM to GSM Handover back to the Anchor MSC (message sequence chart)

### 8.4.3.3 Subsequent Inter-MSC GSM to GSM Handover back to the anchor MSC for A Interface over IP

When the MSC-A server receives the MAP Prepare Subsequent Handover Request message, it requests the MGW -A to reserve an RTP bearer termination using the Reserve RTP Connection Point procedure. The MSC-A server requests the MGW -A to reserve an IP address and UDP port. The MSC-A server uses the Change Flow Direction procedure to request the MGW-A to set the Handover Device to initial state.

The MGW-A reserves the RTP termination and indicates the IP address and UDP port number to the MSC-A server. The IP addresses and UDP ports of the MGW -A is sent to the BSC-B in the BSSMAP Handover Request message. When the MSC-A server receives the BSSMAP Handover Request-Ack message, it shall send the BSC-A IP address and UDP Port number to the MGW -B using the Configure RTP Connection Point procedure.

The sequence is shown in Figure 8.4.3.3/1.

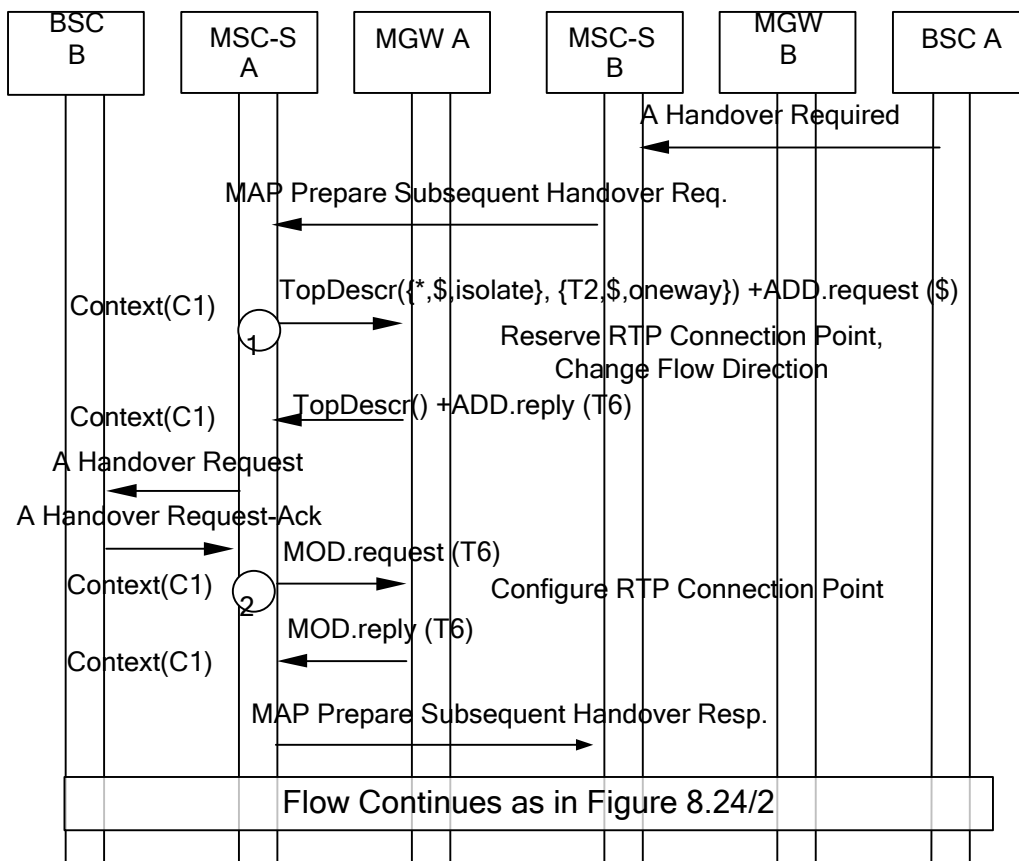


Figure 8.4.3.3/1: Subsequent Inter-MSC GSM to GSM Handover back to the anchor MSC for AoIP (message sequence chart)

### 8.4.4 Subsequent GSM to GSM Handover to a third MSC

The GSM to GSM handover to a third MSC server (from MSC-B server to MSC-B server) is the combination of the two previous inter-MSC handover cases:

- for MSC-B server a subsequent GSM to GSM handover from MSC-B server back to MSC-A server as described in clause 8.4.3; and
- for MSC-B server a basic GSM to GSM handover from MSC-A server to MSC-B server as described in clause 8.4.2.

MSC-A server implements the corresponding parts of each handover case, i.e. access handling in MSC-A server is not included.

## 8.4.5 BSS Internal Handover

### 8.4.5.1 Introduction

The procedures specified in 3GPP TS 23.009 [8] for "BSS Internal Handover" shall be followed. The protocol messages are defined in 3GPP TS 48.008 [27]. The following clauses describe the additional requirements for the bearer independent CS core network due to BSS internal handover for A-Interface User Plane over IP (AoIP).

A BSS Internal Handover may be initiated by the BSS on its own, or triggered by the MSC server with the transmission of an Internal Handover Enquiry message to the BSS.

### 8.4.5.2 Internal Handover Required

When the MSC server receives an Internal Handover Required message, it requests the MGW to seize a TDM circuit using the Reserve Circuit procedure or an RTP termination using the Reserve and Configure RTP Connection Point procedure. In the latter case, the MSC server sends the BSC IP address and UDP port and the determined A-Interface Codec Type/Configuration to the MGW and requests the MGW to reserve a local IP address and UDP port.

**NOTE:** During a BSS Internal handover procedure involving an IP-based target A-Interface Type before and after the handover, the BSC IP addresses and UDP ports used before and after the handover may be identical or different. This is transparent to the MSC Server. In the former case, the BSC can receive on its BSC IP address and UDP port identical RTP flows received from the source and target access terminations reserved in the MGW.

For non-speech calls the MSC server shall provide the MGW with the GSM Channel coding properties and the same PLMN Bearer Capability as was provided at the last access bearer assignment. The MSC server uses the Change Flow Direction procedure to request the MGW to set the Handover Device to initial state.

The MGW reserves the TDM circuit or RTP termination and indicates in the latter case its own IP address and UDP port to the MSC server. The MSC server then sends the Internal Handover Command message to the BSC containing the speech codec type/configuration chosen and either the CIC or the MGW IP address and UDP port.

If the resources requested by the BSS in the Internal Handover Required message (e.g. codec type or codec configuration, interface type, etc.) are not available, an Internal Handover Required Reject message shall be returned to the BSS with the appropriate failure cause, and the procedure shall be terminated.

### 8.4.5.3 Internal Handover Command/Handover Detect

When the MSC server sends the Internal Handover Command message or alternatively if it receives the Handover Detect message, the MSC server uses the Change Flow Direction procedure to request the MGW to set the Handover Device to intermediate state (bullet 2 in figure 8.4.5.8.2).

### 8.4.5.4 Handover Complete

When the MSC server receives the Handover Complete message, it requests the MGW to set the Handover Device to its final state by removing the bearer termination towards the source BSC IP address and UDP port number, using the Release Termination procedure (bullet 3 in figure 8.4.5.8.2).

### 8.4.5.5 Interworking function

The interworking function used by the MGW before handover will also be used after handover.

### 8.4.5.6 Voice Processing function

After handover, the MGW may continue or modify voice processing function(s) provided to each bearer termination.

### 8.4.5.7 Failure Handling in MSC server

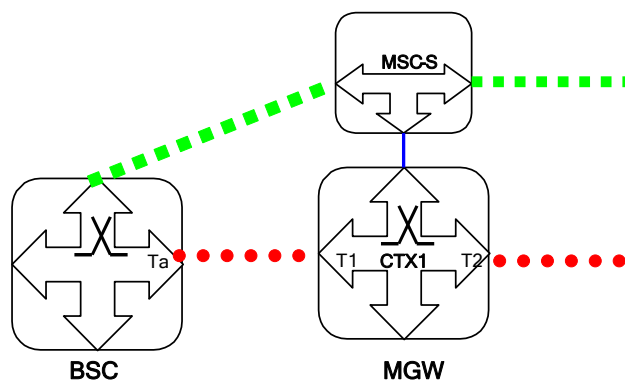
When a procedure between the MSC server and the MGW fails the MSC server shall handle the failure as an internal error in accordance with 3GPP TS 23.009 [8] and 3GPP TS 29.010 [23]. If MGW resources have already been seized

for BSS internal handover then the resources shall be released using the Release Termination procedure. If the call is to be cleared, then it shall be handled as described in clause 7.3.

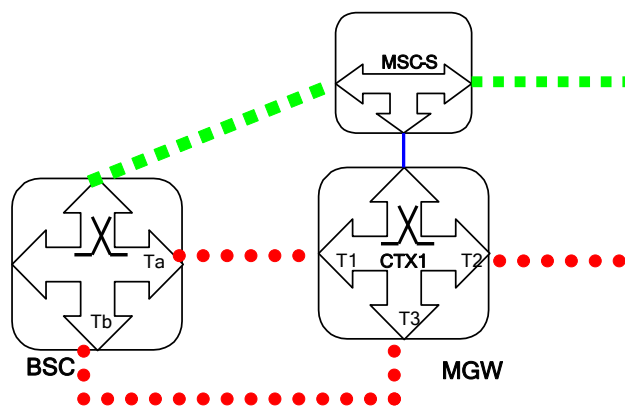
If the MSC server receives the Handover Failure message during BSS internal handover procedure, it shall release MGW resources if they have been seized for BSS internal handover using the Release Termination procedure.

### 8.4.5.8 Example for a successful BSS Internal Handover

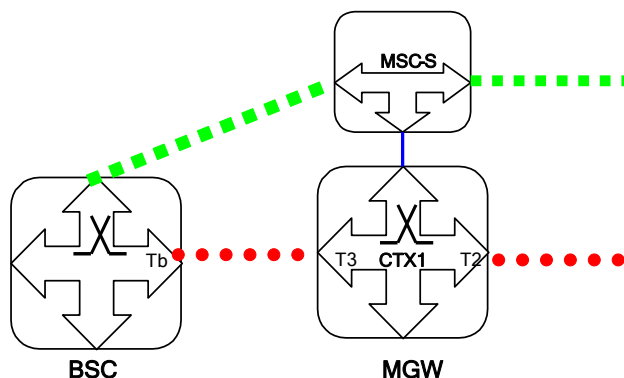
Figure 8.4.5.8.1 shows the network model for the BSS Internal Handover, where IP transport is used on the A interface before and after the BSS Internal Handover procedure. The "squared" line represents the call control signalling. The "dotted" line represents the bearer. The bearer termination T1 is used for the bearer towards the source BSC IP address and UDP port number Ta, bearer termination T3 is used for the bearer towards the target BSC IP address and UDP port number Tb and the bearer termination T2 is used for the bearer towards the succeeding/preceding MGW.



Before BSS Internal Handover



During BSS Internal Handover



**After BSS Internal Handover**

**Figure 8.4.5.8.1: Intra-MSC BSS Internal Handover (network model)**

Figure 8.4.5.8.2 shows the message sequence example for the Intra-MSC BSS Internal Handover.

In the example, the MSC server receives the Internal Handover Required message and requests the MGW to reserve an RTP bearer termination (T3) using the Reserve and Configure RTP Connection Point procedure with specific flow directions.

The MSC server starts the Internal Handover execution by sending the Internal Handover Command towards the BSC in which it provides the IP address and UDP port of the target MGW RTP termination (T3). When the handover is detected in the BSC, the MSC server requests the MGW to change the flow directions between the terminations within the context. When the MSC server receives the Handover Complete indication from the BSC it requests the MGW to release the bearer termination T1 towards the source BSC IP address and UDP port number Ta that was used before the BSS Internal Handover was initiated. The sequence is shown in Figure 8.4.5.8.2.

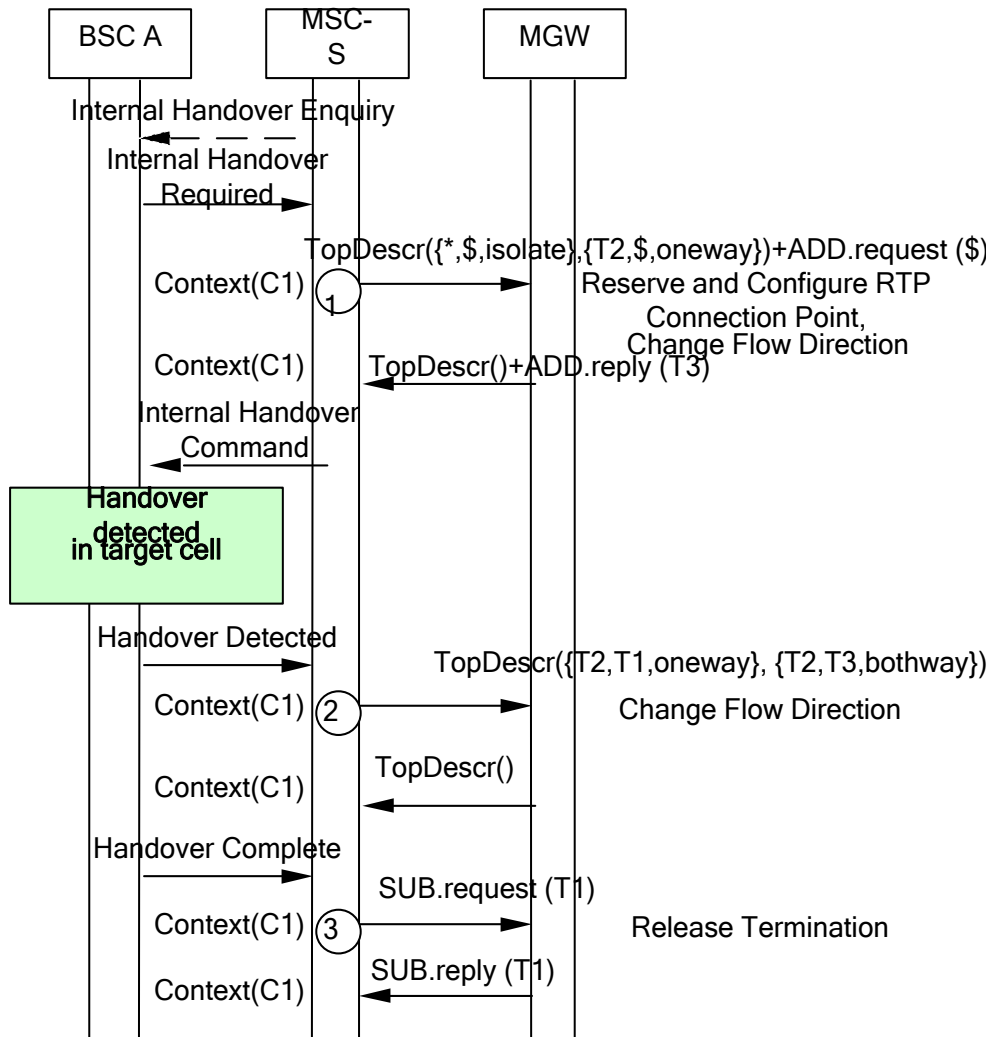


Figure 8.4.5.8.2: Intra-MSC BSS Internal Handover for AoIP (message sequence chart)

## 8.5 Handling of GSM Services after UMTS to GSM Handover

The handling of GSM services after handover in the Bearer Independent CS Core Network architecture is as for the corresponding UMTS services, if not stated differently.

# 9 Compatibility Issues

A Release 4 (or later) node, according to 3GPP TS 23.205, is backward compatible with a Release 99 (or earlier) node.

## 9.1 Interworking with GERAN (A i/f)

### 9.1.1 Introduction

The A-interface signalling terminates in the MSC server and the user plane terminates in the MGW. TDM and/or IP transports may be supported on the A-interface. The MSC server uses the Mc interface to remotely control the TDM or IP resources in the MGW.

For intra-MSC handover, the target A-interface is handled as described in clause 8. If the target A-interface user plane terminates in a different MGW from the MGW that terminates the serving A-interface user plane, a bearer has to be established between the two MGWs using Prepare Bearer and Establish Bearer procedures. Because the same MSC server controls both MGWs, no external call control signalling is involved.



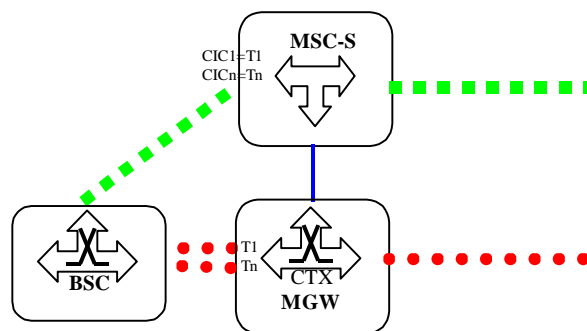
It is important to note that the separation between the user and control planes remains the same before and after interaction with services in the 3G BICC CSCN.

## 9.1.2 A interface over TDM

Only one MSC server may control the TDM circuits connected to one GERAN node.

For each TDM circuit a physical termination is provisioned in the MGW. The TDM circuit is identified by the termination Id in the Mc interface. Since TDM circuits are also grouped together, the physical termination Ids are structured in accordance with the grouping of TDM circuits. The MSC server also knows the termination Ids and the grouping of termination Ids. The physical termination exists as long as the TDM circuit(s) exists in the MGW.

Figure 9.1 shows the network model for the A-interface. The "squared" line represents the call control signalling and the "dotted" line represents the TDM circuits. The terminations T1-Tn represent the TDM circuits in the MGW. The MSC server has a mapping table between circuits CIC1-CICn and the terminations T1-Tn.



**Figure 9.1 TDM circuits used for A-interface (network model)**

For call-independent transactions the general (G)MSC server-MGW procedures, as described in clause 10, apply to the physical terminations in the same way as to any other terminations.

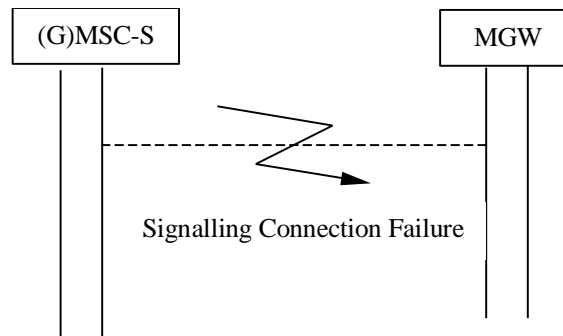
For call related transactions the handling as described in the clauses 6, 7 and 8 apply to physical terminations in the same way as any other terminations. All call related procedures, except Prepare Bearer, Establish Bearer, Release Bearer and Tunnel Information Up/Down, as described in clause 16, apply to the physical terminations in the same way as any other terminations.

# 10 General (G)MSC server-MGW Procedures

## 10.1 MGW Unavailable

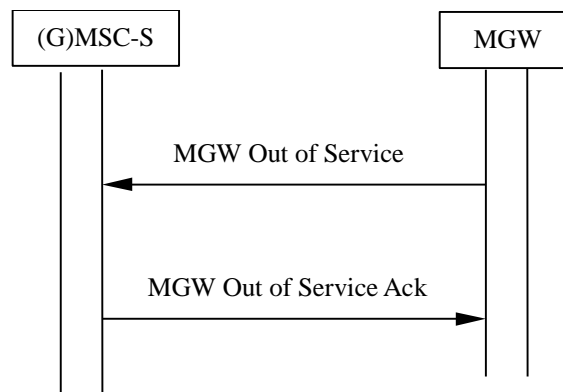
The (G)MSC server recognises that the MGW is unavailable in the following 4 cases:

1. The signalling connection is unavailable



**Figure 10.1: Signalling connection failure**

2. The MGW indicates the failure condition to all connected (G)MSC servers



**Figure 10.2: MGW indicates the Failure/Maintenance locking**

The failure indication indicates that the MGW will soon go out of service and that no new connections should be established using this MGW. The MGW can choose between the "graceful" and the "forced" method. In the graceful method the connections are cleared when the corresponding calls are disconnected. In the forced method all connections are cleared immediately.

3. The (G)MSC server recognises that the MGW is not functioning correctly, e.g. because there is no reply on periodic sending of Audits. The periodic sending of Audits by (G)MSC server should go on.
4. The MGW indicates the maintenance locking condition to all concerned (G)MSC servers.

The maintenance locking indication indicates that the MGW is locked for new calls and that no new connections shall be established using this MGW. The MGW can choose between the "graceful" and the "forced" method. In the graceful method the connections are cleared when the corresponding calls are disconnected. In the forced method all connections are cleared immediately.

In all of the above cases the (G)MSC server shall prevent the usage of the MGW until the MGW has recovered or the communication with the MGW is restored. The (G)MSC server shall prohibit the surrounding network from seizing circuits connected to the unavailable TDM access by sending blocking messages.

## 10.2 MGW Available

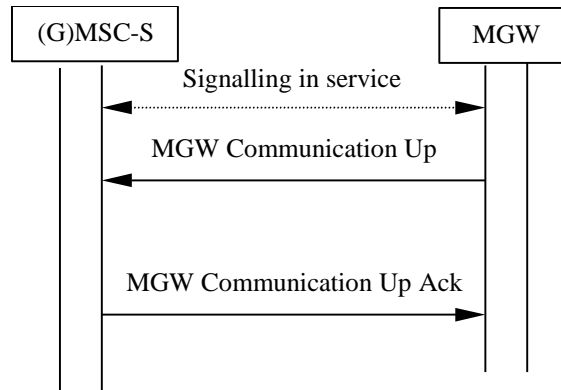
The (G)MSC server discovers that the MGW is available when it receives an MGW Communication Up message or an MGW Restoration message. If the (G)MSC does not wish to sustain an association with the MGW, the response sent to the MGW may indicate an alternative MGCI signalling address, in which case the MGW shall not consider itself registered and should preferably attempt to re-register with this alternative MGCI before any further alternate MGCI. Otherwise, the response shall not indicate any alternative MGCI signalling address.

When the (G)MSC server discovers that the MGW is available the following shall occur:

1. Signalling recovery

The MGW indicates to all connected (G)MSC servers that the signalling connection is restored. Any changes to the physical termination state during the loss of communication shall be reported by the MGW using Termination Out Of Service (10.7) or Termination Restoration (10.8), otherwise the (G)MSC Server can assume that Terminations service state has not changed. To avoid unsuccessful calls for physical terminations which went out of service during the loss of communication but have not yet been reported by the MGW the MSC Server may Audit the physical terminations before it uses them.

NOTE: Auditing in this case will cause duplicate signalling.

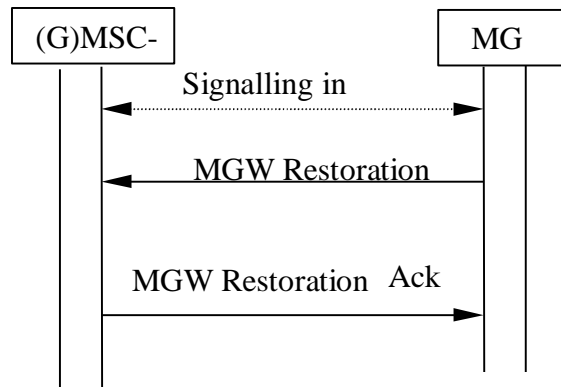


**Figure 10.3: Communication goes up**

2. MGW restoration/maintenance unlocking indication.

The MGW indicates to all connected (G)MSC servers that normal operation has resumed. Changes of the physical termination state during the connection break shall be reported by the MGW using Termination Out Of Service (10.7) and Termination restoration (10.8) procedures, otherwise the (G)MSC Server can assume that Terminations service state has not changed. To avoid unsuccessful calls for physical terminations which went out of service during the loss of communication but have not yet been reported by the MGW the (G)MSC Server may Audit the physical terminations before it uses them.

NOTE: Auditing in this case will cause duplicate signalling.



**Figure 10.4: MGW indicates recovery from a failure/or maintenance unlocking**

NOTE: This procedure may be used after recovery from a signalling failure.

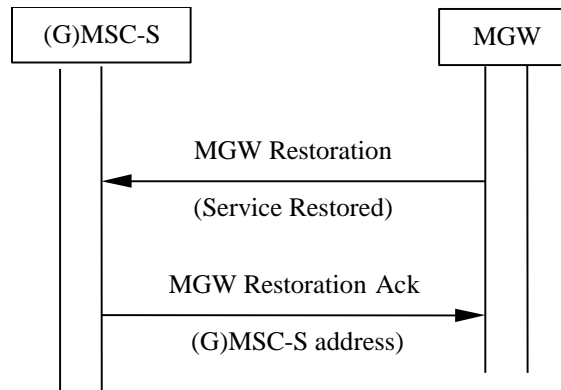
3. The (G)MSC server recognises that the MGW is now functioning correctly, e.g. because there is a reply on periodic sending of Audits.

After this the (G)MSC server can use the MGW. If the corresponding devices of the surrounding network are blocked, unblocked messages shall be sent to the nodes concerned for devices that are in service: the (G)MSC Server has determined the actual state of the physical devices either by receiving Termination Restoration procedure (10.8) or by performing an Audit..

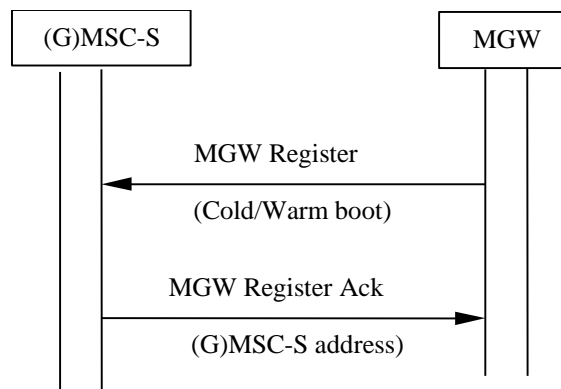
If none of 1,2, and 3 happens the (G)MSC server can initiate the (G)MSC Server Ordered Re-register procedure.

## 10.3 MGW Recovery

If the MGW recovers from a failure, is maintenance unlocked, or it has been restarted, it registers to its known (G)MSC servers using the MGW Restoration procedure or the MGW Registration procedure. The MGW can indicate whether the Service has been restored or whether it has restarted with a cold or warm boot. If the (G)MSC does not wish to sustain an association with the MGW, the response sent to the MGW may indicate an alternative MGCIId signalling address, in which case the MGW shall not consider itself registered and should preferably attempt to re-register with this alternative MGC before any further alternate MGCs. Otherwise, the response shall not indicate any alternative MGCIId signalling address.



**Figure 10.5/1: MGW Restoration**



**Figure 10.5/2 MGW Registration**

After the recovery the (G)MSC server can use the MGW. After a MGW warm boot or service restored, the (G)MSC Server can assume the physical terminations state has not changed. Changes of the physical termination state during the connection break shall be reported by the MGW using Termination Out Of Service (10.7) and Termination restoration (10.8) procedures. To avoid unsuccessful calls for physical terminations which went out of service during the loss of communication but have not yet been reported by the MGW the MSC Server may Audit the physical terminations before it uses them.

NOTE: Auditing in this case will cause duplicate signalling.

After receiving a MGW Register (with cold boot) the (G)MSC Server shall audit the termination state of all physical terminations (10.9) if it has not been specifically informed of the actual service state since receiving the MGW service change on ROOT (Register) via independent service change commands (10.7 or 10.8). The (G)MSC Server shall thereby determine the actual Service State of devices. If the corresponding devices of the surrounding network are blocked, unblocked messages are sent to the nodes concerned for all devices that are in service.

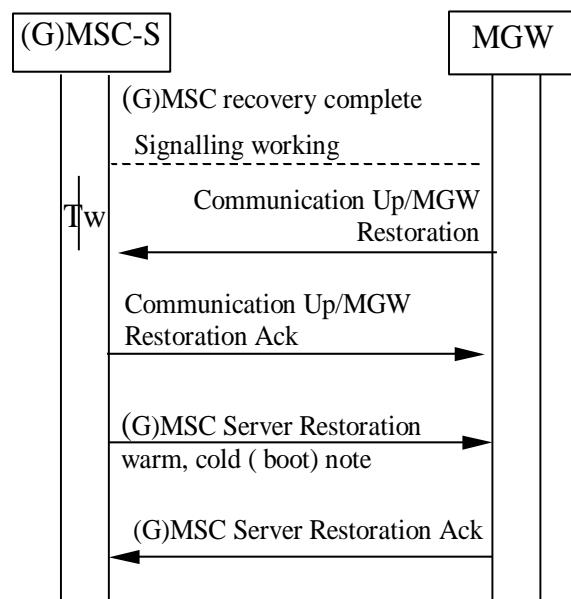
## 10.4 (G)MSC server Recovery

### 10.4.1 General

If an MGW -unavailable condition is provoked by a failure/recovery action, the (G)MSC server recovery sequence will, from an information flow point of view, look like MGW unavailable and then MGW available. If an MGW -unavailable condition is not provoked, the (G)MSC server recovery sequence will look like MGW available.

After the information flow, the terminations affected by the recovery action are released.

### 10.4.2 (G)MSC Server Restoration



**Figure 10.6: (G)MSC Server Restoration**

NOTE: Normal release procedure may also be initiated.

After the recovery action is complete and it is possible to signal to the MGW the (G)MSC server starts a timer  $T_w$ . If recovery indications are not received (MGW Communication Up or MGW Restoration) from the MGW during  $T_w$  an Audit is sent. If the (G)MSC server receives a recovery indication or MGW communication up indication, it shall acknowledge the indication before the (G)MSC Server Restoration may be sent or the release procedure is initiated.

## 10.5 MGW Re-register

When the (G)MSC requests an MGW to perform a registration (see clause 10.2, 10.3 and 10.6), the MGW performs a re-registration to the (G)MSC which is defined in the (G)MSC address. If the (G)MSC Server is uncertain of the termination service state of physical terminations after the Re-Register it shall use the Audit Procedure (10.9). Changes of the physical termination state during the connection break shall be reported by the MGW using Termination Out Of Service (10.7) and Termination restoration (10.8) procedures.

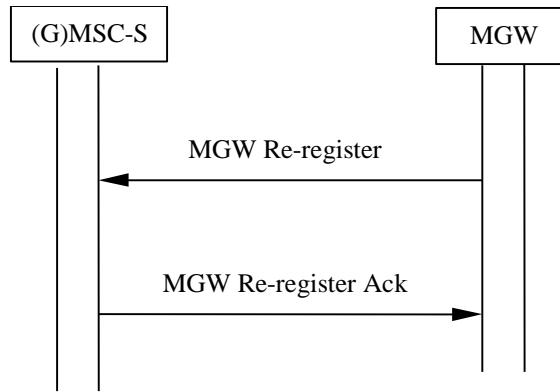


Figure 10.7: Re-registration of an MGW

### 10.6 MGW Re-registration Ordered by (G)MSC server

If the (G)MSC server knows that communication is possible, but the MGW has not registered, the (G)MSC server can order re-registration of the MGW.

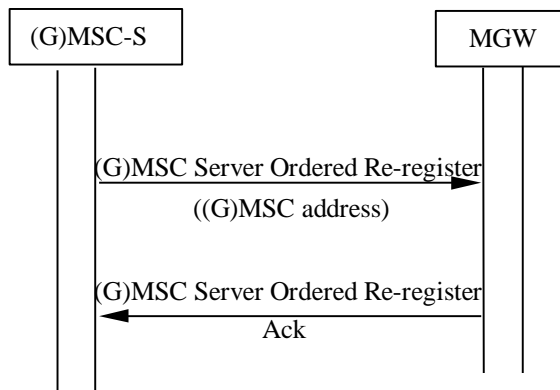
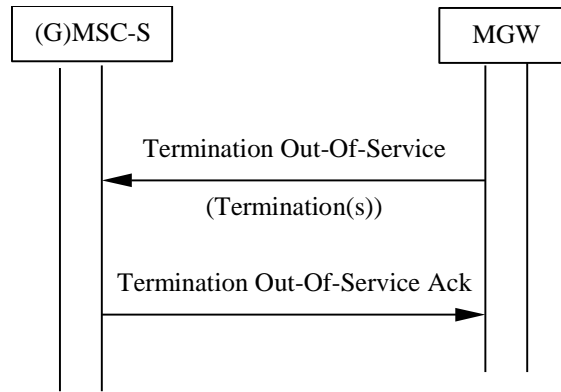


Figure 10.8: Re-registration ordered by the (G)MSC server

If the re-registration request is accepted the MGW uses the MGW Re-register procedure to register with the (G)MSC server.

### 10.7 Removal from Service of a Physical Termination

The MGW indicates the removal from service of a physical termination using the Termination Out-of-Service procedure. In this procedure the MGW indicates which termination is to be removed from service and whether the "graceful" or "forced" method will be used. In the graceful method a possible connection is cleared when the corresponding call is disconnected. In the forced method the possible connection is cleared immediately.

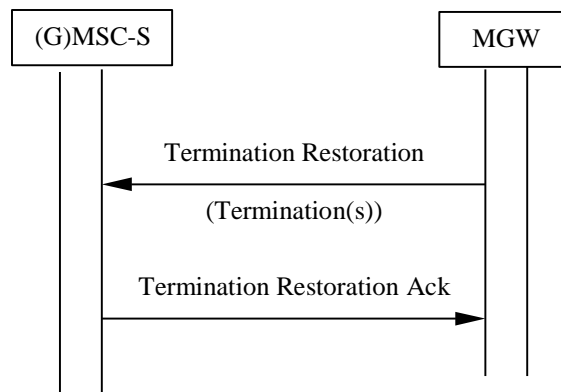


**Figure 10.9: Removal from service of a Physical Termination**

The (G)MSC server shall prevent the use of the Termination(s) concerned until the physical termination is restored to service.

## 10.8 Restoration to Service of a Physical Termination

If the physical termination is restored to service, the MGW shall report it to the (G)MSC server(s) using the Termination Restoration procedure.



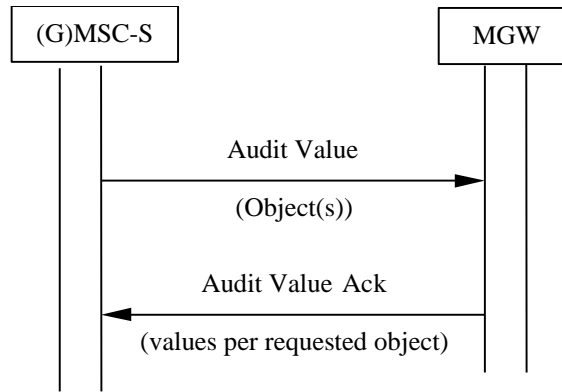
**Figure 10.10: Restoration to service of a Physical Termination**

The (G)MSC server can use the physical termination when the termination has been restored to service. If the corresponding devices of the surrounding network are blocked, the (G)MSC server sends an unblocked message to each node concerned.

## 10.9 Audit of MGW

### 10.9.1 Audit of Value

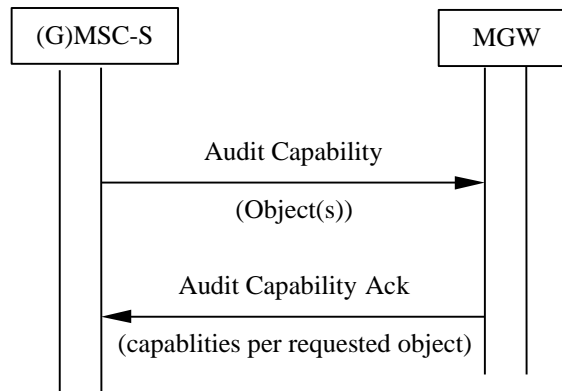
The (G)MSC server may request the MGW to report the current values assigned to distinct objects in the MGW. Objects, which can be addressed, are listed in 3GPP TS 29.232 [6]. This procedure shall be used when a change has occurred in the (G)MSC server such that the server is unsure of the current Service State of Terminations, such as restart or new trunks configured in the server. For any situation where a change to the Service State occurs in the MGW the (G)MSC server shall expect the Service State to be reported by Termination Restoration (10.8) or Termination Out Of Service (10.7).



**Figure 10.11: Audit Value**

### 10.9.2 Audit of Capability

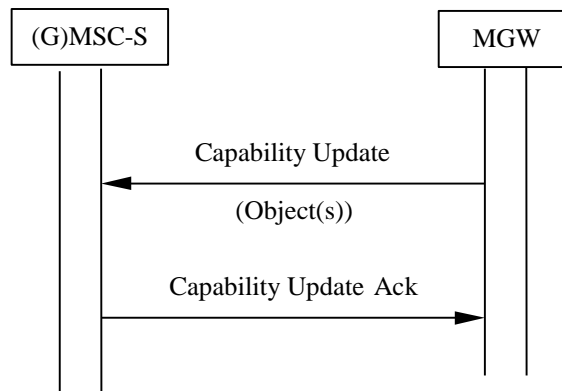
The (G)MSC server may request the MGW to report the capabilities of distinct objects in the MGW. Objects, which can be addressed, are listed in 3GPP TS 29.232 [6].



**Figure 10.12: Audit Capability**

### 10.10 MGW Capability Change

The MGW reports a change of capability of distinct objects in the MGW. Objects, which can be addressed, are listed in 3GPP TS 29.232 [6].



**Figure 10.13: Capability Update**

The (G)MSC server can use the Audit Value and/or Audit Capability procedures to obtain further information, about the objects whose capabilities have changed.



### 10.11 Void

### 10.12 (G)MSC Server Out of service

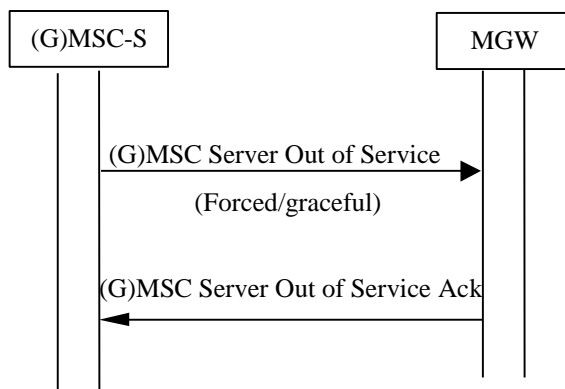


Figure 10.14: (G)MSC Server Out of Service

If a (G)MSC server discovers that it wants to go out of service it starts a (G)MSC Server Out of Service procedure. The (G)MSC server can indicate whether it requires the context to be cleared immediately (forced) or cleared as the bearer control protocol clears the bearer (Graceful). Physical terminations are always cleared when the (G)MSC Server Out of Service indication reaches the MGW.

### 10.13 MGW Resource Congestion Handling - Activate

When the (G)MSC server requires that a MGW congestion notification mechanism be applied in the MGW, the (G)MSC server shall use the MGW Resource Congestion Handling - Activate procedure towards the MGW.

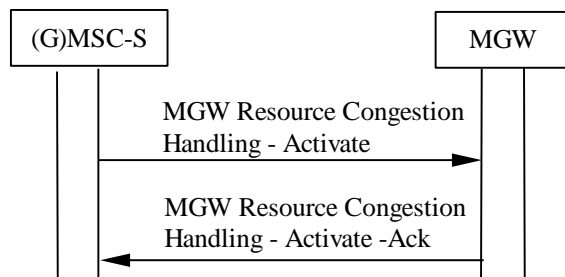


Figure 10.15: MGW Resource Congestion Handling - Activate

### 10.14 MGW Resource Congestion Handling -Indication

When the (G)MSC server receives a load reduction notification from the MGW via the MGW Resource Congestion Handling - Indication procedure, the (G)MSC server tries to reduce the processing load that the (G)MSC server creates on the MGW. The MGW shall decide the actual level of traffic reduction.

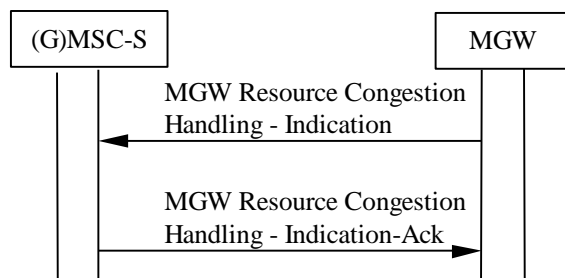


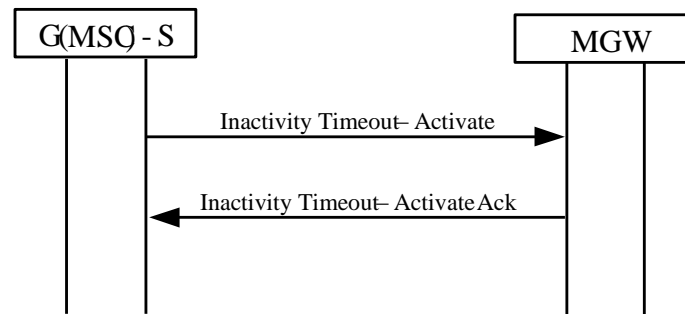
Figure 10-17: MGW Resource Congestion Handling – Indication

## 10.15 Control association monitoring

Monitoring of the H.248 control association may be performed by monitoring the status of the transport link association where the transport protocol provides sufficient coupling to the H.248.1 protocol, i.e. if the transport link association is disconnected when no local H.248.1 protocol connection exists.

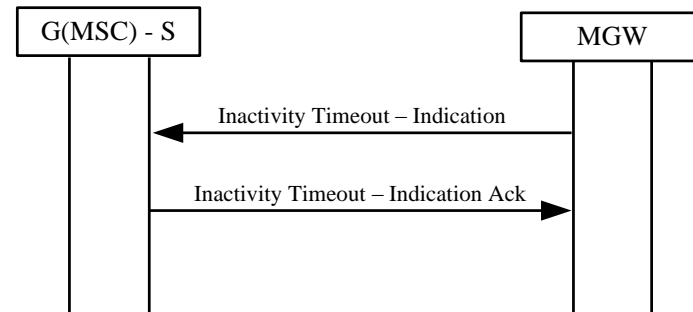
An alternative method for the MGW to detect loss of the MGC may be achieved by requesting the MGW to poll the (G)MSC periodically

Upon registration of a MGW, the (G)MSC server may use the Inactivity Timeout - Activate procedure towards the MGW to request the MGW to monitor incoming messages for periods of silence exceeding the maximum inactivity timer value.



**Figure 10.15.1: Inactivity Timeout - Activate**

Upon receipt of an inactivity timeout notification from the MGW via the Inactivity Timeout -Indication procedure, the (G)MSC server shall send a reply to the MGW. If the MGC has failed, the MGW will not receive a reply.



**Figure 10.15.2: Inactivity Timeout - Indication**

If no Inactivity Timeout – Indication Ack reply is received, the MGW shall consider the (G)MSC to have failed. The MGW may then attempt to recontact its controlling (G)MSC by performing MGW Communication UP. If not successful, the MGW may then attempt to register to a new (G)MSC.

## 10.16 Hanging termination detection

Whenever requesting new ephemeral bearer terminations, the (G)MSC shall request the MGW to periodically report termination heartbeat indications to detect hanging context and termination in the MGW that may result e.g. from a loss of communication between the MSC-S and the MGW. This may also be done when requesting TDM terminations, though alternative means exist for the (G)MSC to detect hanging TDM terminations, e.g. via receipt of the error #433 when seizing the termination.

When the (G)MSC server receives a termination heartbeat notification from the MGW via the Termination heartbeat - Indication procedure, the (G)MSC shall return a Termination heartbeat –Indication Ack (without an error) if the context id / termination identity combination exists in the (G)MSC. If it does not exist, the (G)MSC shall return an error and

shall correct the mismatch, e.g. by requesting the MGW to subtract the indicated termination and to clear any associated context.

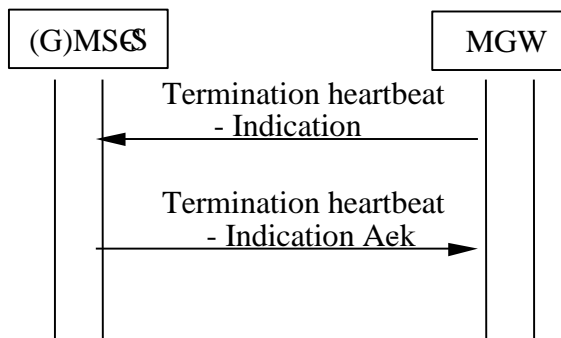


Figure 10.16.1: Termination heartbeat – Indication

---

## 11 Identities

### 11.1 Bearer Address and Binding Reference

The Bearer Address is exchanged on the Nc and Mc interfaces to identify the termination point of the bearer control signalling within the peer Media Gateway.

A Binding Reference is an identity, unique within the scope of one bearer control function, which identifies a bearer network connection. This information is exchanged on the Nc and Mc interfaces. The bearer control function is identified by the Bearer Address.

### 11.2 MGW-Id

The Media Gateway Identity (MGW-Id) is information sent on the Nc interface to aid Media Gateway selection by the succeeding/preceding node.

The MGW-Id is bearer independent and it can be translated into a signalling address towards the appropriate MGW.

### 11.3 (G)MSC server Address

The (G)MSC server Address defines the signalling address associated with the (G)MSC server that is used to interact with the Media Gateway over the Mc interface. This is a unique address in the network service supplier domain.

---

## 12 Operational Aspects

### 12.1 Charging

No impacts.

---

## 13 Interactions with Other Services

NOTE 1: All message sequence charts in this clause are informative examples.

NOTE 2: The continuity indication in the IAM is not used to indicate that a continuity check will be performed on the current leg of the call, but it is used to indicate that a Continuity message can be expected as a result of a continuity check on a preceding ISUP circuit, or establishment of a preceding bearer connection.

## 13.1 Enhanced Multi-Level Precedence and Pre-emption service (eMLPP)

No impact.

## 13.2 Call Deflection Service

The procedures specified in 3GPP TS 23.072 [9] for the Call Deflection supplementary service shall be followed. The following clauses describe the additional requirements for the bearer independent CS core network.

### 13.2.1 MGW selection and incoming side bearer establishment

The MGW selected for the mobile terminating call is used. The incoming side bearer has already been established by the mobile terminating call procedures.

### 13.2.2 IU/A-interface release

If the call deflection request from a served subscriber is accepted the call towards the served mobile subscriber shall be released as described in the clause for call clearing.

### 13.2.3 Notification to the Calling Subscriber

If the served mobile subscriber has requested that the calling subscriber shall receive a notification about the call forwarding, a notification is sent to the calling party. If the notification is implemented using intermediate tones or announcements the MSC server requests the MGW to play an announcement/tone to the calling party, as described in clause 14.6, before establishing the call to the forwarded-to subscriber.

### 13.2.4 Initial addressing

The call towards the deflected-to subscriber is established as for basic call. If out-of-band transcoder control is applied for a speech call, it shall be performed in accordance with 3GPP TS 23.153 [3]. After the possible generation of in-band information has been completed the MSC server shall indicate in the IAM that forward or backward bearer establishment is to be used. The MSC server shall indicate in the IAM that no Continuity message will follow since the incoming bearer has already been established.

The MGW-id can be provided to the succeeding node in the IAM.

### 13.2.5 Establishment of bearer towards the forwarded-to subscriber

The bearer establishment towards the forwarded-to subscriber is performed as described for the mobile originating call, network side bearer establishment, using either forward or backward bearer establishment. The MSC server also requests the MGW to both-way through-connect the bearer.

### 13.2.6 Failure handling in MSC server

The failures are handled as described for the basic mobile originating call.

### 13.2.7 Example

Figure 13.1 shows the network model for call deflection. The "squared" line represents the call control signalling. The "dotted" line represents the bearer control signalling and the bearer. Note that for a TDM access case there is no separation of call and bearer control signalling. The MSC server replaces the bearer termination for the served mobile

subscriber ( $T_B$ ) with the bearer termination for the deflected-to subscriber ( $T_C$ ) in an existing context in the MGW. The bearer termination  $T_A$  is used for the bearer towards the preceding MGW (calling subscriber).

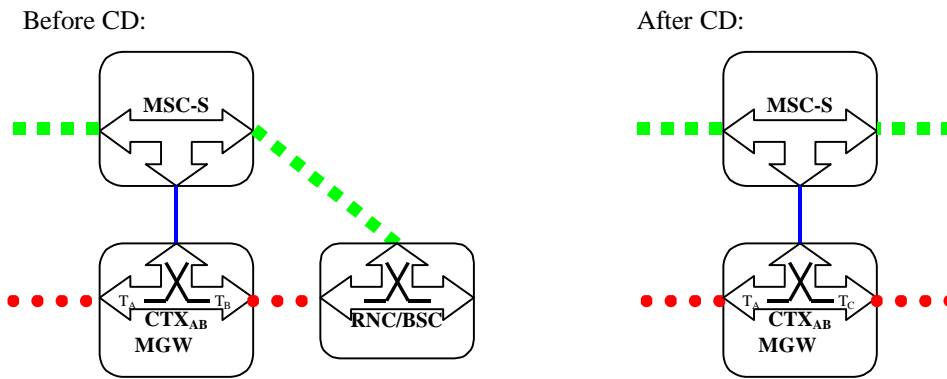
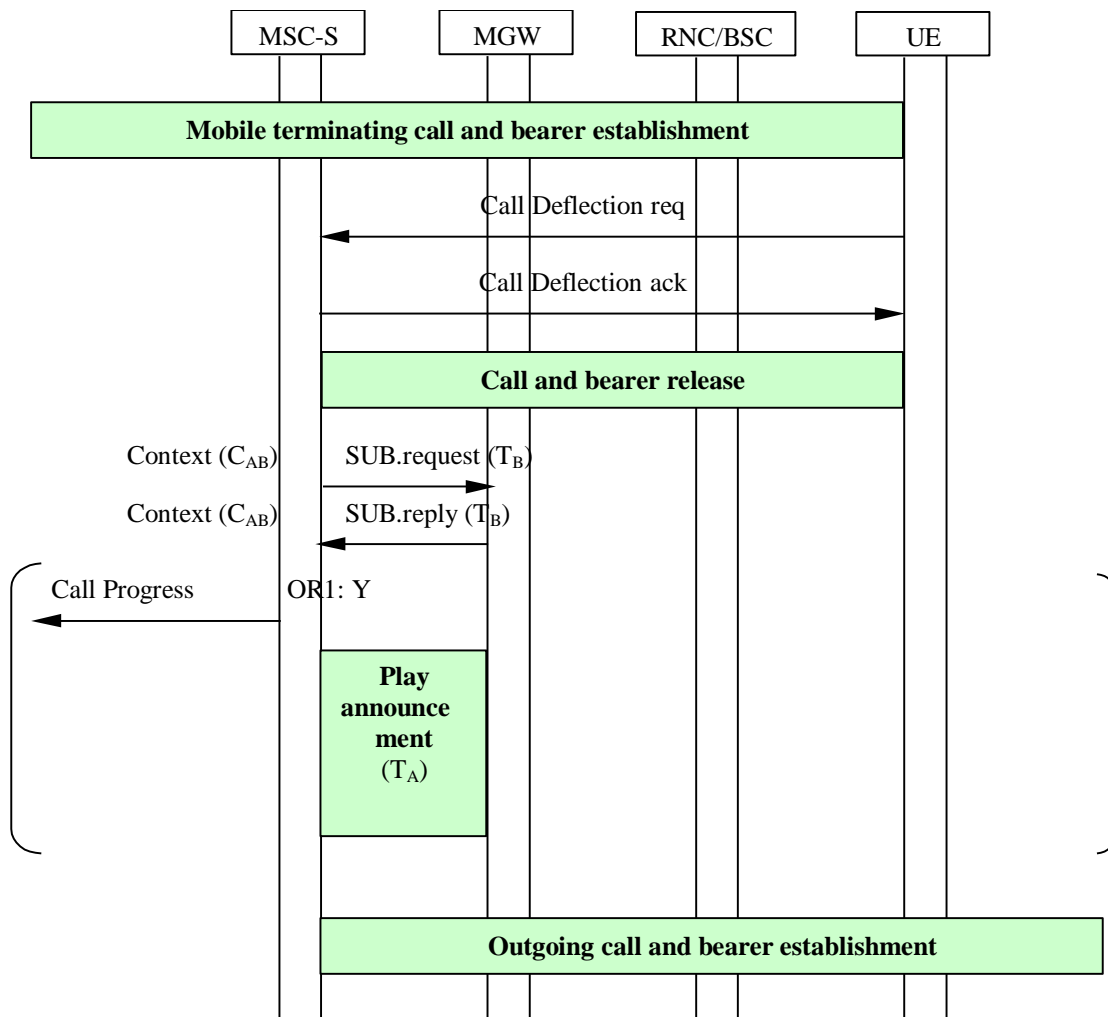


Figure 13.1: Call deflection (Network model)

Figure 13.2 shows the message sequence example for the call deflection with a possible notification to the calling party using an announcement. In the example, after the call and the bearer towards the access side have been released the MSC server requests the MGW to remove the bearer termination for the served mobile subscriber, and optionally requests the MGW to play an announcement and to notify the announcement completion. The MSC server shall request the establishment of the call towards the deflected-to subscriber after the possible announcement has completed.



NOTE: OR1: Notification to calling subscriber required (Y:yes N:no)

Figure 13.2: Call deflection (message sequence chart)

## 13.3 Line identification Services

### 13.3.1 Calling Line Identification Presentation (CLIP)

No impact.

### 13.3.2 Calling Line Identification Restriction (CLIR)

No impact.

### 13.3.3 Connected Line Identification Presentation (COLP)

No impact.

### 13.3.4 Connected Line Identification Restriction (COLR)

No impact.

## 13.4 Call Forwarding Services

### 13.4.1 Call Forwarding Unconditional (CFU)

The procedures specified in 3GPP TS 23.082 [12] for the Call Forwarding Unconditional supplementary service shall be followed. The following clauses describe the additional requirements for the bearer independent CS core network.

#### 13.4.1.1 MGW selection

If in-band information is to be provided to the calling subscriber the GMSC server shall select the MGW before providing the in-band information. The MGW selection can be based on a possibly received MGW-Id from the preceding node.

If in-band information is to not to be provided to the calling subscriber the GMSC server shall select the MGW for the bearer as described for the basic mobile terminating call.

#### 13.4.1.2 Incoming side bearer establishment

The incoming side bearer establishment is handled in the GMSC server as described for the mobile terminating call using either forward or backward bearer establishment.

#### 13.4.1.3 Notification to the Calling Subscriber

If the served mobile subscriber has requested that the calling subscriber shall receive a notification about the call forwarding, a notification is sent to the calling party. If the notification is implemented using intermediate tones or announcements the GMSC server requests the MGW to play an announcement/tone to the calling party, as described in clause 14.6, before establishing the call to the forwarded-to subscriber.

#### 13.4.1.4 Initial addressing

If the incoming call is to be forwarded without being offered to the served mobile subscriber the call towards the forwarded-to subscriber is established as for a basic call. If out-of-band transcoder control is applied for a speech call, it shall be performed in accordance with 3GPP TS 23.153 [3]. After the possible generation of in-band information has been completed the initial addressing towards the forwarded-to subscriber is performed as described for the basic mobile terminating call indicating either forward or backward bearer establishment.

### 13.4.1.5 Establishment of bearer towards the forwarded-to subscriber

The bearer establishment towards the forwarded-to subscriber is performed as described for the mobile originating call, network side bearer establishment, using either forward or backward bearer establishment. The GMSC server also requests the MGW to both-way through-connect the bearer.

### 13.4.1.6 Confirmation of bearer establishment

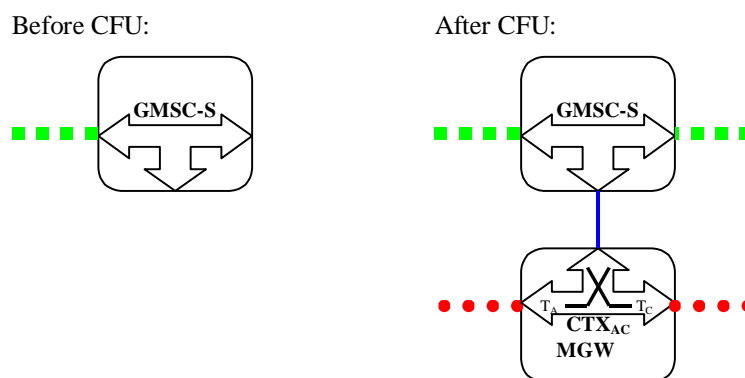
The confirmation of the bearer establishment is handled as described for the basic mobile terminating call.

### 13.4.1.7 Failure handling in GMSC server

The failures are handled as described for the basic mobile terminating call.

### 13.4.1.8 Example

Figure 13.3 shows the network model for call forwarding unconditional. The "squared" line represents the call control signalling. The "dotted" line represents the bearer control signalling and the bearer. The GMSC server seizes one context with two bearer terminations in the MGW. The bearer termination  $T_A$  is used for the bearer towards the preceding MGW (calling subscriber) and the bearer termination  $T_C$  is used for the bearer towards the succeeding MGW (forwarded-to subscriber).



**Figure 13.3: CFU (Network model)**

Figure 13.4 shows the message sequence example for the call forwarding unconditional with a possible notification to the calling party using an announcement. In the example the GMSC server optionally requests the MGW to play an announcement and to notify the announcement completion, after the bearer to the incoming side has been established. When the possible announcement has completed the GMSC server requests the establishment of the call and the bearer towards the forward-to subscriber.

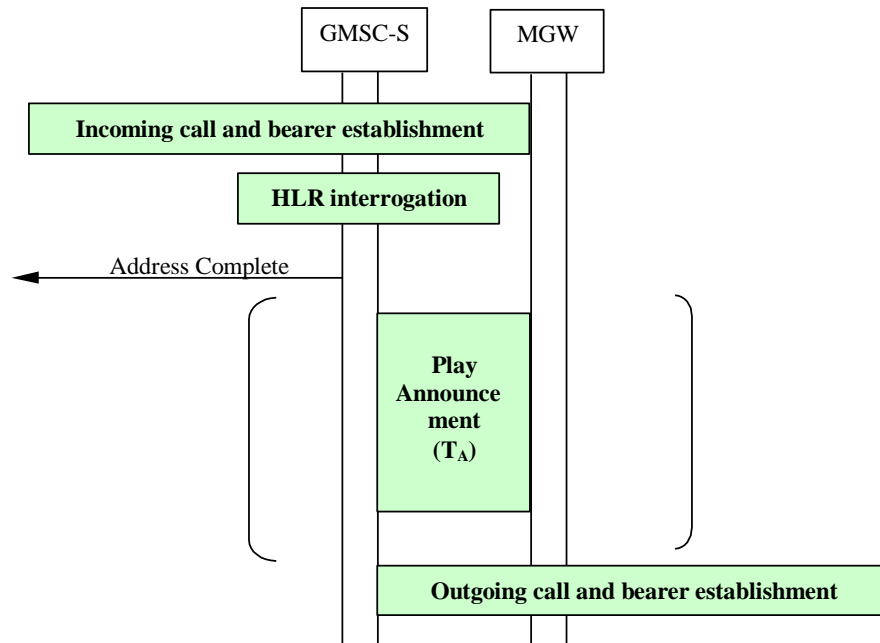


Figure 13.4: CFU (message sequence chart)

## 13.4.2 Call Forwarding on mobile subscriber Busy (CFB)

The procedures specified in 3GPP TS 23.082 [12] for the Call Forwarding on Busy supplementary service shall be followed. The following clauses describe the additional requirements for the bearer independent CS core network.

### 13.4.2.1 Network Determined User Busy (NDUB)

If the mobile is Network Determined User Busy the incoming call for the specified basic service(s) shall be forwarded without being offered to the served mobile subscriber.

#### 13.4.2.1.1 MGW selection

The MSC server shall select an MGW for the bearer connection either before sending the IAM or after receiving the Bearer Information message. If the MSC server received an MGW -id from the preceding node and/or from the succeeding node, then it may use one of them for the MGW selection.

If in-band information is to be provided to the calling subscriber the MSC server shall select the MGW before providing the in-band information. The MGW selection can be based on a possibly received MGW -Id from the preceding node.

**NOTE:** As an implementation option, if there is no need for the MSC server to manipulate the bearer, the MSC server may only perform call control signalling without any associated MGW. In that case the bearer related information shall be provided transparently through the MSC server.

#### 13.4.2.1.2 Incoming side bearer establishment

The incoming side bearer establishment is handled in the MSC server as described for the mobile terminating call using either forward or backward bearer establishment. The incoming side bearer establishment can take place either before or after the detection of NDUB condition.

#### 13.4.2.1.3 Notification to the calling subscriber

If the served mobile subscriber has requested that the calling subscriber shall receive a notification about the call forwarding, a notification is sent to the calling party. If the notification is implemented using intermediate tones or announcements the MSC server requests the MGW to play an announcement/tone to the calling party, as described in clause 14.6, before establishing the call to the forwarded-to subscriber.



#### 13.4.2.1.4 Initial addressing

The call towards the forwarded-to subscriber is established as for basic call. If out-of-band transcoder control is applied for a speech call, it shall be performed in accordance with 3GPP TS 23.153 [3]. In-band information may be played to the calling subscriber.

If no in-band information is to be played to the calling subscriber, in order to withhold the call completion until the establishment of the bearer is complete.

The MSC server shall indicate in the IAM that the Continuity message will follow from the preceding node if either of the following conditions is satisfied before sending the IAM:

1. The incoming IAM indicated that the Continuity message will follow, but no Continuity message has been received, or
2. The incoming side bearer has not been established.

If the MGW is selected at an early stage the MGW-id can be provided to the succeeding node in the IAM.

#### 13.4.2.1.5 Establishment of bearer towards the forwarded-to subscriber

The bearer establishment towards the forwarded-to subscriber is performed as described for mobile originating call, network side bearer establishment, using either forward or backward bearer establishment. The MSC server also requests the MGW to both-way through-connect the bearer.

#### 13.4.2.1.5 Confirmation of bearer establishment

If the outgoing IAM indicated that the Continuity message will follow, the Continuity message is sent when both of the following conditions are satisfied:

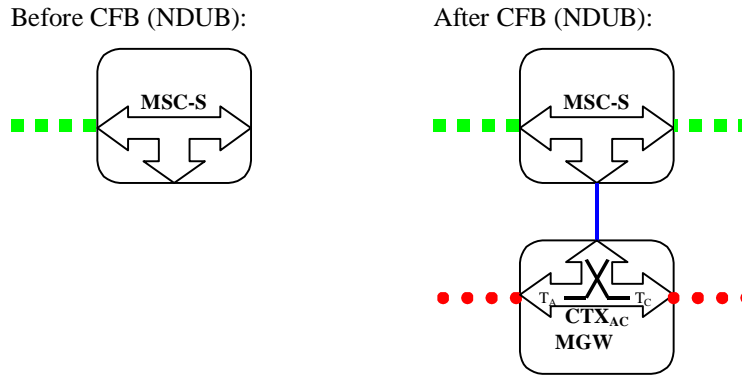
1. Either:
  - a. The incoming IAM indicated that the Continuity message will follow, and a Continuity message has been received, or
  - b. The incoming IAM indicated that no Continuity message will follow.
2. Either:
  - a. The MSC server has selected an MGW, and a notification indicating successful completion of the incoming side bearer set-up has been received from the MGW using the Bearer Established procedure, or
  - b. MGW selection is not required for this call.

#### 13.4.2.1.6 Failure handling in MSC server

The failures are handled as described for the basic mobile originating call.

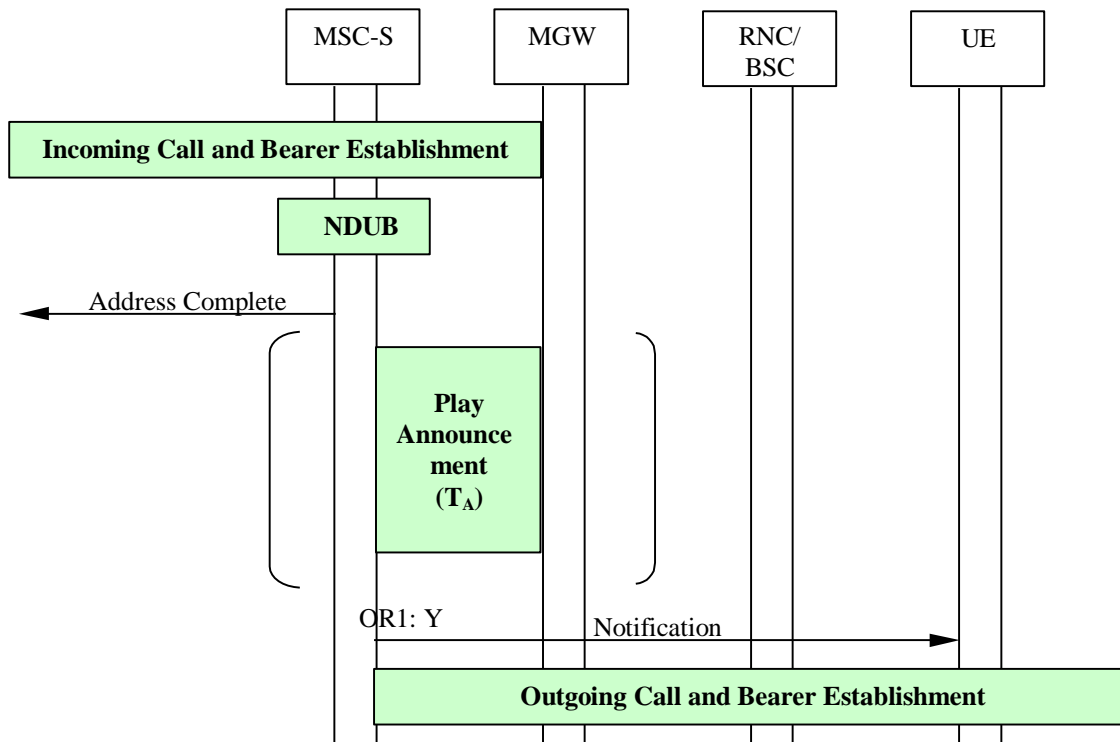
#### 13.4.2.1.7 Example

Figure 13.5 shows the network model for call forwarding busy (network determined user busy). The "squared" line represents the call control signalling. The "dotted" line represents the bearer control signalling and the bearer. The MSC server seizes one context with two bearer terminations in the MGW. The bearer termination  $T_A$  is used for the bearer towards the preceding MGW (calling subscriber) and the bearer termination  $T_C$  is used for the bearer towards the succeeding MGW (forwarded-to subscriber).



**Figure 13.5: CFB; NDUB (Network model)**

Figure 13.6 shows the message sequence example for the call forwarding busy (network determined user busy) using a possible announcement. In the example the MSC server optionally requests the MGW to play an announcement and to notify the announcement completion, after the bearer to the incoming side has been established. When the possible announcement has been completed the MSC server requests the establishment of the call towards the forward-to subscriber.



NOTE: OR1: Notification to forwarding subscriber required (Y: yes N: no)  
 NDUB: Network Determined User Busy

**Figure 13.6: CFB (NDUB)**

13.4.2.2 User Determined User Busy (UDUB)

13.4.2.2.1 MGW selection

The MGW selected for the mobile terminating call is used, if already selected by the mobile terminating call procedures.

The MSC server selects an MGW for the bearer either before sending the IAM or after receiving the Bearer Information message. If the MSC server received an MGW-id from the preceding node and/or from the succeeding node, then it may use one of them for the MGW selection.

If in-band information is to be provided to the calling subscriber the MSC server shall select the MGW before providing the in-band information. The MGW selection can be based on a possibly received MGW -Id from the preceding node.

NOTE: As an implementation option, if there is no need for the MSC server to manipulate the bearer, the MSC server may only perform call control signalling without any associated MGW. In that case the bearer related information shall be provided transparently through the MSC server.

#### 13.4.2.2.2 Incoming side bearer establishment

For bearer establishment, the sending of bearer information is handled in the MSC server as described for the basic mobile terminating call indicating either forward or backward bearer establishment. The incoming side bearer establishment can take place either before or after the detection of UDUB condition.

#### 13.4.2.2.3 IU/A-interface release

If the mobile is not Network Determined User Busy (NDUB as defined in GSM TS 02.01) the incoming call is offered (as a normal or waiting call) to the served mobile subscriber. If the mobile indicating "User Busy" subsequently releases the call, the call towards the served mobile subscriber is released as described in the clause for call clearing.

NOTE: The MSC server orders the MGW to remove the bearer termination towards the served mobile subscriber only in the case where the radio resources had already been allocated in the MGW (bullet 1 in figure 13.8).

#### 13.4.2.2.4 Notification to the Calling Subscriber

If the served mobile subscriber has requested that the calling subscriber shall receive a notification about the call forwarding, a notification is sent to the calling party. If the notification is implemented using intermediate tones or announcements the MSC server requests the MGW to play an announcement/tone to the calling party as described in clause 14.6 before establishing the call to the forwarded-to subscriber.

#### 13.4.2.2.5 Initial addressing

The call towards the forwarded-to subscriber is established as basic call. If out-of-band transcoder control is applied for a speech call, it shall be performed in accordance with 3GPP TS 23.153 [3]. In-band information may be played to the calling subscriber.

If no in-band information is to be played to the calling subscriber, in order to withhold the call completion until the establishment of the bearer is complete. The MSC server shall indicate in the IAM that the Continuity message will follow from the preceding node if either of the following conditions is satisfied before sending the IAM:

1. The incoming IAM indicated that the Continuity message will follow, but no Continuity message has been received, or
2. The incoming side bearer has not been established.

If the MGW is selected at an early stage the MGW-id can be provided to the succeeding node in the IAM.

#### 13.4.2.2.6 Establishment of bearer towards the forwarded-to subscriber

The bearer establishment towards the forwarded-to subscriber is performed as described for the mobile originating call, network side bearer establishment, using either forward or backward bearer establishment. The MSC server also requests the MGW to both-way through-connect the bearer.

#### 13.4.2.2.7 Confirmation of bearer establishment

If the outgoing IAM indicated that the Continuity message will follow, the Continuity message is sent when both of the following conditions are satisfied:

1. Either:

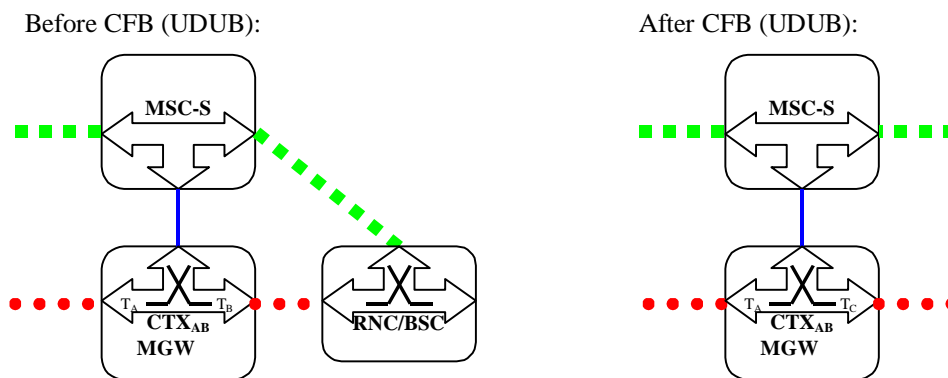
- a. The incoming IAM indicated that the Continuity message will follow, and a Continuity message has been received from the preceding node (bullet 8 in figure 6.6), or
  - b. The incoming IAM indicated that no Continuity message will follow;
2. Either:
- a. The MSC server has selected an MGW, and a notification of successful bearer establishment in the incoming side has been received from the MGW (bullet 7 in figure 6.6), or
  - b. MGW selection is not required for this call.

#### 13.4.2.2.8 Failure handling in MSC server

The failures are handled as described for the basic mobile originating call.

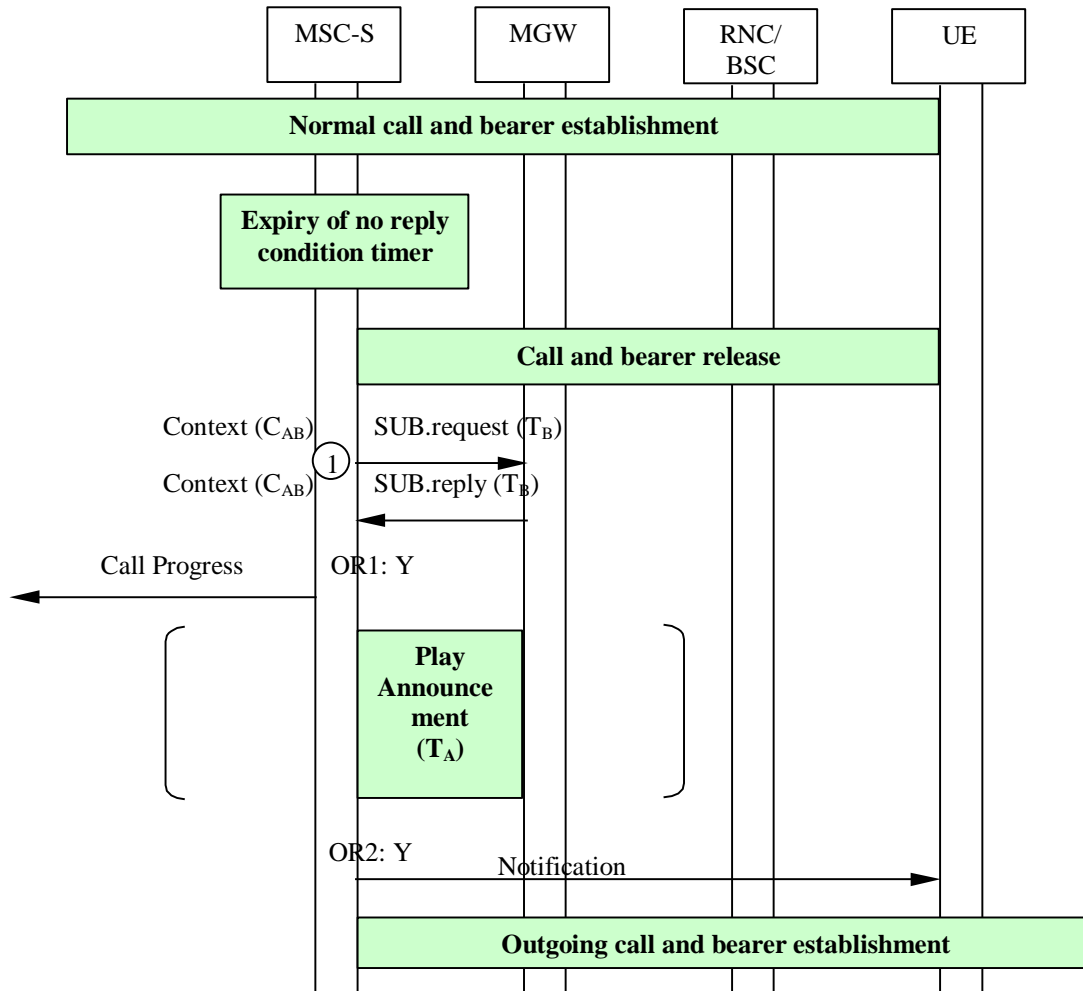
#### 13.4.2.2.9 Example

Figure 13.7 shows the network model for call forwarding busy (user determined user busy). The "squared" line represents the call control signalling. The "dotted" line represents the bearer control signalling and the bearer. Note that for a TDM access case there is no separation of call and bearer signalling. The MSC server replaces the bearer termination for the served mobile subscriber ( $T_B$ ) with the bearer termination for the forwarded-to subscriber ( $T_C$ ) in an existing context in the MGW. The bearer termination  $T_A$  is used for the bearer towards the preceding MGW (calling subscriber).



**Figure 13.7: CFB; UDUB (Network model)**

Figure 13.8 shows the message sequence example for the call forwarding busy (user determined user busy) with a possible notification to the calling party using an announcement. In the example, after the call and the bearer towards the access have been released the MSC server requests the MGW to remove the bearer termination for the served mobile subscriber, optionally requests the MGW to play an announcement and to notify the announcement completion. After the possible announcement has been completed the MSC server requests the establishment of the call towards the forward-to subscriber.



NOTE: OR1: Notification to calling subscriber required (Y:yes N:no)

Figure 13.8: CFB (UDUB)

### 13.4.3 Call Forwarding on No Reply (CFNRy)

The procedures specified in 3GPP TS 23.082 [12] for the Call Forwarding on No Reply supplementary service shall be followed. The following clauses describe the additional requirements for the bearer independent CS core network.

#### 13.4.3.1 MGW selection and incoming side bearer establishment

The MGW selected for the mobile terminating call is used. The incoming side bearer has already been established by the mobile terminating call procedures.

#### 13.4.3.2 IU/A-interface release

If the call is not answered within the period defined by the no reply condition timer the call towards the served mobile subscriber will be released as described in the clause for call clearing.

#### 13.4.3.3 Notification to the Calling Subscriber

If the served mobile subscriber has requested that the calling subscriber shall receive a notification about the call forwarding, a notification is sent to the calling party. If the notification is implemented using intermediate tones or announcements the MSC server requests the MGW to play an announcement/tone to the calling party, as described in clause 14.6, before establishing the call to the forwarded-to subscriber.

### 13.4.3.4 Initial addressing

The call towards the forwarded-to subscriber is established as a basic call. If out-of-band transcoder control is applied for a speech call, it shall be performed in accordance with 3GPP TS 23.153 [3]. After the possible generation of in-band information has been completed (bullet 2 in figure 13.10) the MSC server shall indicate in the IAM that no Continuity message will follow from the preceding node because the incoming side bearer has already been established.

The MGW-id can be provided to the succeeding node in the IAM.

### 13.4.3.5 Establishment of bearer towards the forwarded-to subscriber

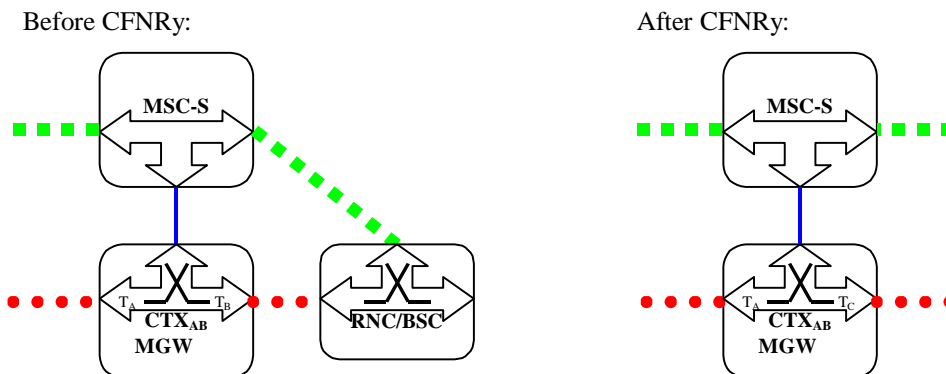
The bearer establishment towards the forwarded-to subscriber is performed as described for the mobile originating call, network side bearer establishment, using either forward or backward bearer establishment. The MSC server also requests the MGW to both-way through-connect the bearer.

### 13.4.3.6 Failure handling in MSC server

The failures are handled as described for the basic mobile originating call.

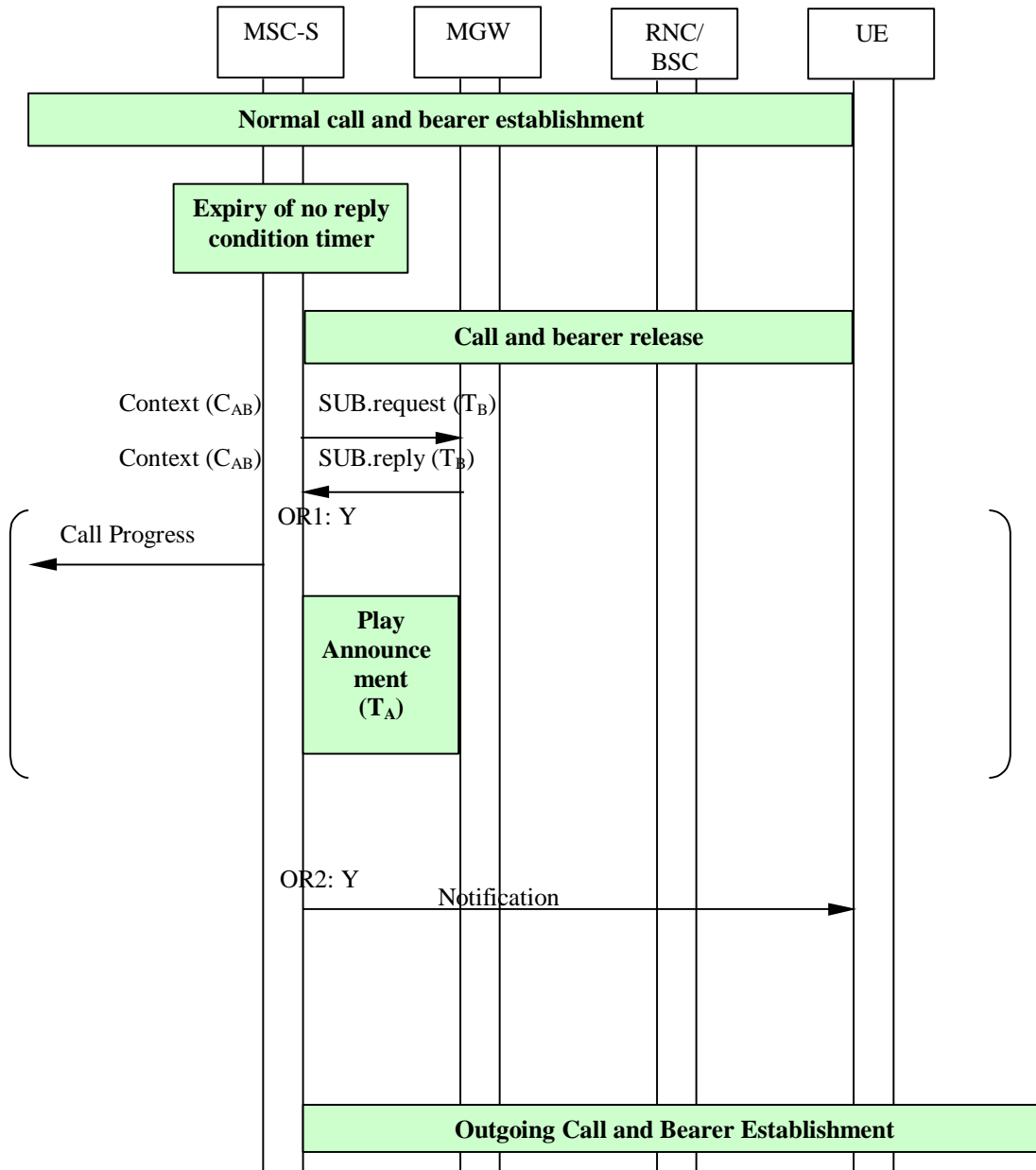
### 13.4.3.7 Example

Figure 13.9 shows the network model for call forwarding no reply. The "squared" line represents the call control signalling. The "dotted" line represents the bearer control signalling and the bearer. Note that for a TDM access case there is no separation of call and bearer control signalling. The MSC server replaces the bearer termination for the served mobile subscriber ( $T_B$ ) with the bearer termination for the forwarded-to subscriber ( $T_C$ ) in an existing context in the MGW. The bearer termination  $T_A$  is used for the bearer towards the preceding MGW (calling subscriber).



**Figure 13.9: CFNRy (Network model)**

Figure 13.10 shows the message sequence example for the call forwarding on no reply with a possible announcement. In the example, after the call and the bearer towards the access have been released the MSC server requests the MGW to remove the bearer termination for the served mobile subscriber, and optionally requests the MGW to play an announcement and to notify the announcement completion. When the possible announcement has been completed the MSC server requests the establishment of the call towards the forward-to subscriber.



NOTE: OR1: Notification to calling subscriber required (Y:yes N:no)

Figure 13.10: CFNRy (message sequence chart)

### 13.4.4 Call Forwarding on mobile subscriber Not Reachable (CFNRc)

The procedures specified in 3GPP TS 23.082 [12] for the Call Forwarding on Not Reachable supplementary service shall be followed. The following clauses describe the additional requirements for the bearer independent CS core network.

#### 13.4.4.1 Rerouting by HLR

The same handling as for Call Forwarding Unconditional applies.

#### 13.4.4.2 Rerouting by VLR

If the mobile is not reachable the incoming call for the specified basic service(s) will be forwarded without being offered to the served mobile subscriber.

#### 13.4.4.2.1 MGW selection

If in-band information is to be provided to the calling subscriber the MSC server shall select the MGW before providing the in-band information. The MGW selection can be based on a possibly received MGW-Id from the preceding node.

**NOTE:** As an implementation option, if in-band information is not to be provided to the calling subscriber the MSC server may either perform call control without any associated MGW, or reserve resources from an MGW and request bearer establishment through that MGW. In the latter case the MSC server selects an MGW for the bearer either before sending the IAM or after receiving the Bearer Information message. If the MSC server received an MGW-Id from the preceding node and/or from the succeeding node, those can be used for the MGW selection.

#### 13.4.4.2.2 Incoming side bearer establishment

The incoming side bearer establishment is handled in the MSC server as described for the mobile terminating call, using either forward or backward bearer establishment. The incoming side bearer establishment can take place either before or after the detection of the not reachable condition.

#### 13.4.4.2.3 Notification to the calling subscriber

If the served mobile subscriber has requested that the calling subscriber shall receive a notification about the call forwarding, a notification is sent to the calling party. If the notification is implemented using intermediate tones or announcements the MSC server requests the MGW to play an announcement/tone to the calling party, as described in clause 14.6, before establishing the call towards the forwarded-to party.

#### 13.4.4.2.4 Initial addressing

The call towards the forwarded-to subscriber is established as a basic call. If out-of-band transcoder control is applied for a speech call, it shall be performed in accordance with 3GPP TS 23.153 [3]. In-band information may be played to the calling subscriber.

If no in-band information is to be played to the calling subscriber, in order to withhold the call completion until the establishment of the bearer is complete the MSC server shall indicate in the IAM that the Continuity message will follow from the preceding node, if either of the following conditions is satisfied before sending the IAM:

1. The incoming IAM indicated that the Continuity message will follow, but no Continuity message has been received, or
2. The incoming side bearer has not been established.

If the MGW is selected at an early stage the MGW-id can be provided to the succeeding node in the IAM.

#### 13.4.4.2.5 Establishment of bearer towards the forwarded-to subscriber

The bearer establishment towards the forwarded-to subscriber is performed as described for mobile originating call, network side bearer establishment, using either forward or backward bearer establishment. The MSC server also requests the MGW to both-way through-connect the bearer.



### 13.4.4.2.6 Confirmation of bearer establishment

If the outgoing IAM indicated that a Continuity message will follow, the Continuity message shall be sent when both of the following conditions are satisfied:

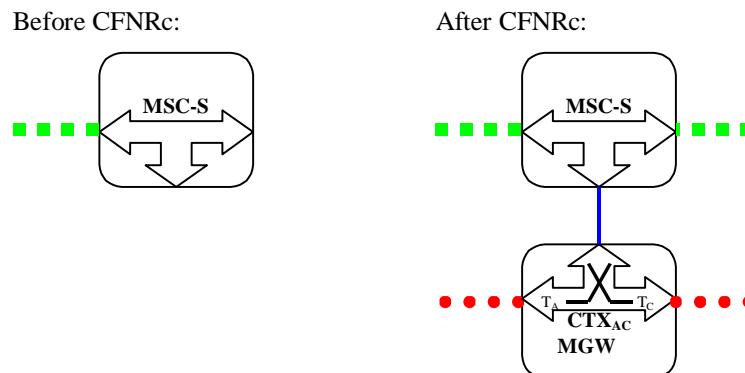
1. Either:
  - a. The incoming IAM indicated that the Continuity message will follow, and a Continuity message has been received, or
  - b. The incoming IAM indicated that no Continuity message will follow.
2. Either:
  - a. The MSC server has selected an MGW, and a notification indicating successful completion of the incoming side bearer set-up has been received from the MGW using the Bearer Established procedure, or
  - b. MGW selection is not required for this call.

### 13.4.4.2.7 Failure handling in MSC server

The failures are handled as described for the basic mobile originating call.

### 13.4.4.2.8 Example

Figure 13.11 shows the network model for call forwarding on not reachable. The "squared" line represents the call control signalling. The "dotted" line represents the bearer control signalling and the bearer. The MSC server seizes one context with two bearer terminations in the MGW. The bearer termination  $T_A$  is used for the bearer towards the preceding MGW (calling subscriber) and the bearer termination  $T_C$  is used for the bearer towards the succeeding MGW (forwarded-to subscriber).



**Figure 13.11: CFNRc; Rerouting by VLR (Network model)**

Figure 13.12 shows the message sequence example for the call forwarding on not reachable with a possible announcement. In the example the MSC server optionally requests the MGW to play an announcement and to notify the announcement completion, after the bearer to the incoming side has been established. When the possible announcement has been completed the MSC server requests the establishment of the call towards the forward-to subscriber.

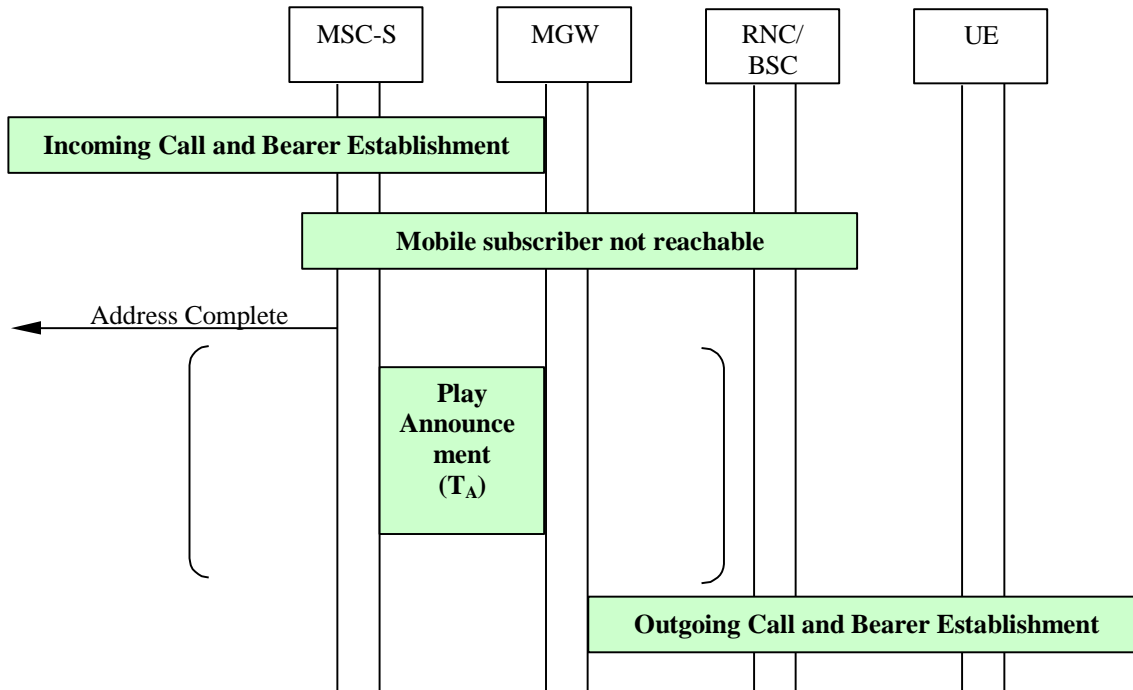


Figure 13.12: CFNRc (Rerouting by VLR) (message sequence chart)

## 13.5 Call Waiting (CW)

The procedures specified in 3GPP TS 23.083 [13] for the Call Waiting supplementary service shall be followed. The following clauses describe the additional requirements for the bearer independent CS core network. The following clauses assume subscriber A to be the served subscriber with the call waiting supplementary service, subscriber B to be the one who is engaged in a call with user A, subscriber C to be the one who has originated a call to subscriber A which causes the call waiting supplementary service to be invoked.

### Call confirmation to the waiting call

The MSC server shall, on reception of the call confirmation, select the MGW that will be used for the waiting call. The MSC server should select the MGW which is already in use for the active call. If out-of-band transcoder control is applied for the waiting speech call, it shall be performed in accordance with 3GPP TS 23.153 [3].

### Existing call on hold

The clause "Hold request" in clause 13.6 applies.

### Existing call released

If the active call is disconnected while another call is waiting, the bearer termination towards the waiting party (C) as well as to the called party (A) is not removed.

### Acceptance of waiting call

If the mobile subscriber decides to accept the waiting call, it handles (according to 3GPP TS 23.083 [13]) the existing call as described in clause 13.5 (i.e. it either puts the call on hold or the call is released). When the MSC server receives the connect indication from subscriber A, if required the MSC server shall modify the access bearer as described in subclause 13.18.1. Finally, the MSC server shall connect the access side bearer termination to the previously created bearer termination of the remote party in the waiting call and modify the waiting call's bearer termination so that it is both-way through-connected.

If a different MGW is selected for the incoming call, then a bearer from the new MGW (MGW 2) shall be connected towards the old MGW (MGW 1) before offering the call to the subscriber A.



### 13.5.1 Call Confirmation of the waiting call

Figure 13.14 shows the sequence chart for the actions necessary within the bearer independent CS core network during call confirmation of the waiting call. Call and bearer establishment shall be as described for the mobile terminating call. When the MSC server receives the Alerting indication from the called subscriber (subscriber A), it shall apply the ringing tone to the waiting termination ( $T_C$ ).

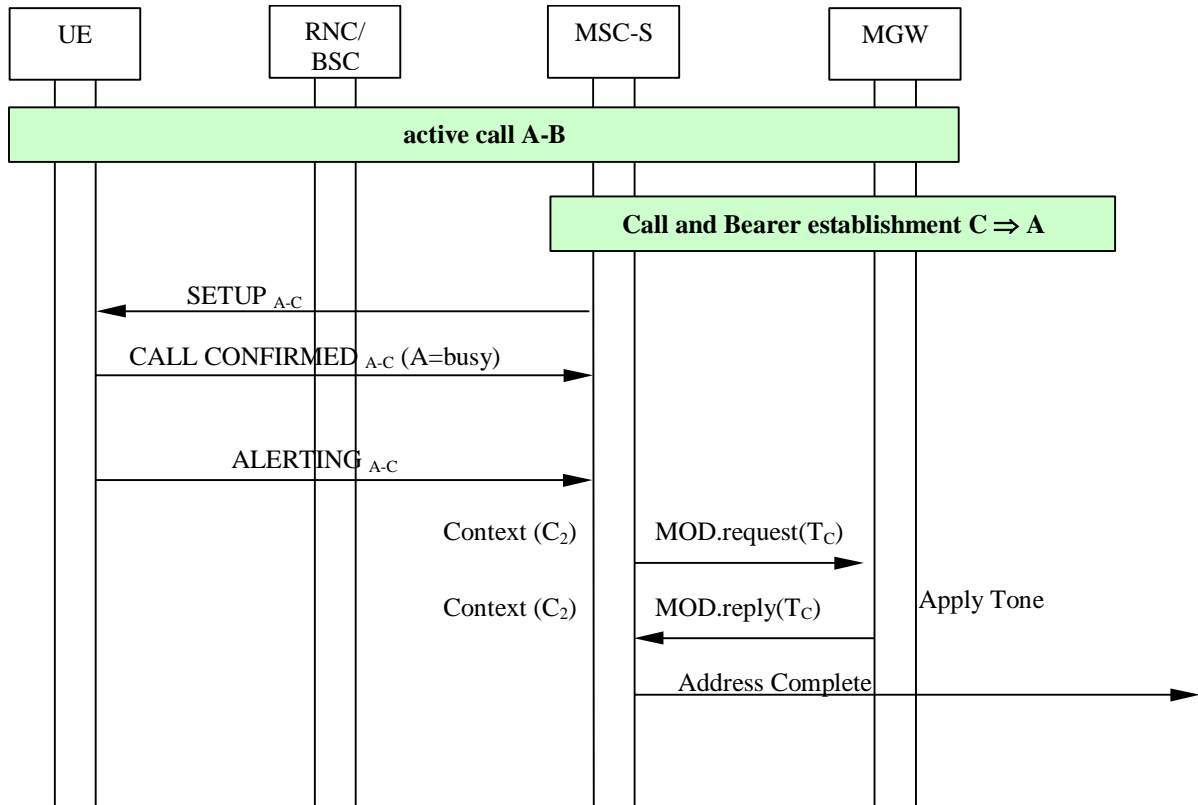


Figure 13.14: Call Confirmation of the Waiting Call.

### 13.5.2 Acceptance of the Waiting Call

Figure 13.15 shows the sequence chart for the actions necessary within the bearer independent CS core network for the acceptance of a waiting call. When the MSC server receives the Connect indication from the UE (subscriber A) (bullet 1 in figure 13.15), it shall request the MGW to disconnect subscriber C from the applied ringing tone (bullet 2 in figure 13.15) and move T<sub>A</sub> to the context of the waiting call (bullet 3 in figure 13.15). The MSC server then requests the MGW to change the through-connection of the termination T<sub>C</sub> so that it will be both way through-connected (bullet 4 in figure 13.15).

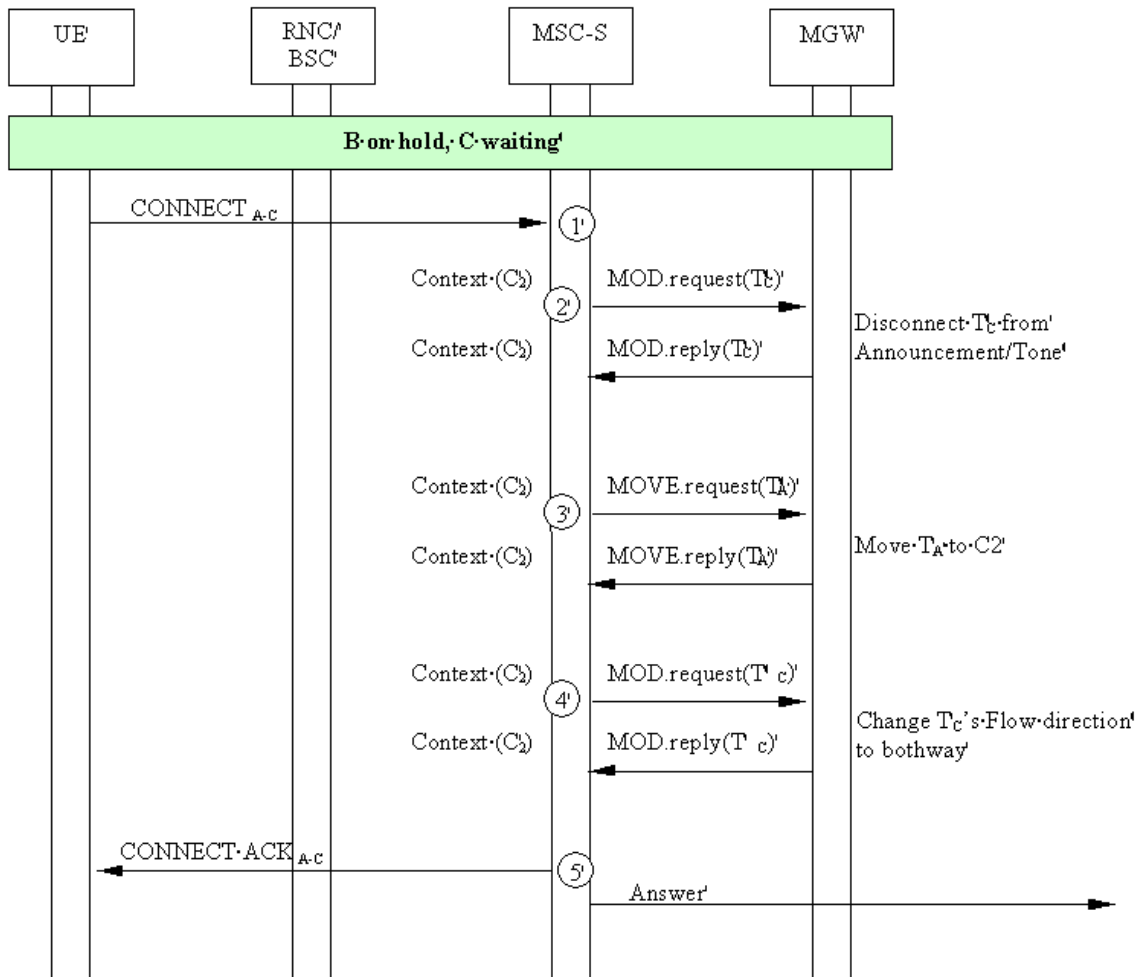


Figure 13.15: Acceptance of the Waiting Call.

## 13.6 Call Hold (CH)

The procedures specified in 3GPP TS 23.083 [13] for the Call Hold supplementary service shall be followed. The following clauses describe the additional requirements for the bearer independent CS core network.

### 13.6.1 Hold request

When the UE makes a request for the hold function the MSC server requests the MGW to interrupt the communication on the bearer by changing the through-connection of the bearer termination towards the served mobile subscriber to "not through-connected" or by using the Isolate Bearer Termination Procedure. Announcements may be applied to the held party as described in clause 14.6.

## 13.6.2 Retrieval request

When the UE makes a request to retrieve a held call the MSC server requests the MGW to re-establish communication to the held party by changing the through-connection of the bearer termination towards the served mobile subscriber to be both-way through-connected or by using the Join Bearer Termination Procedure.

## 13.6.3 Setting up another call

The call towards the C party is established as described for the mobile originating call. A new MGW may be selected in the course of setting up the new call. If out-of-band transcoder control is applied for a speech call, it shall be performed in accordance with 3GPP TS 23.153 [3]. If required, the MSC server shall modify the access bearer for the new call as described in subclause 13.18.1. The MSC server will request the MGW to connect the access side bearer termination to the bearer termination of the remote party.

## 13.6.4 Alternate from one call to the other

When the hold request for the active call is immediately followed by a retrieve request for the held call the MSC server shall request the MGW to connect the bearer termination of the served mobile subscriber to the bearer termination of the held party. The MSC server also requests the MGW to both-way through-connect the bearer for the previously held call.

## 13.6.5 Disconnect

If the active call is disconnected while another call is on hold, the bearer termination towards the served mobile subscriber is not removed but the call towards the active party is disconnected as described in the clause for call clearing.

If the held call is disconnected while the served mobile subscriber is connected to an active call the bearer termination towards the served mobile subscriber shall not be removed but the call towards the held party is disconnected as described in the clause for call clearing.

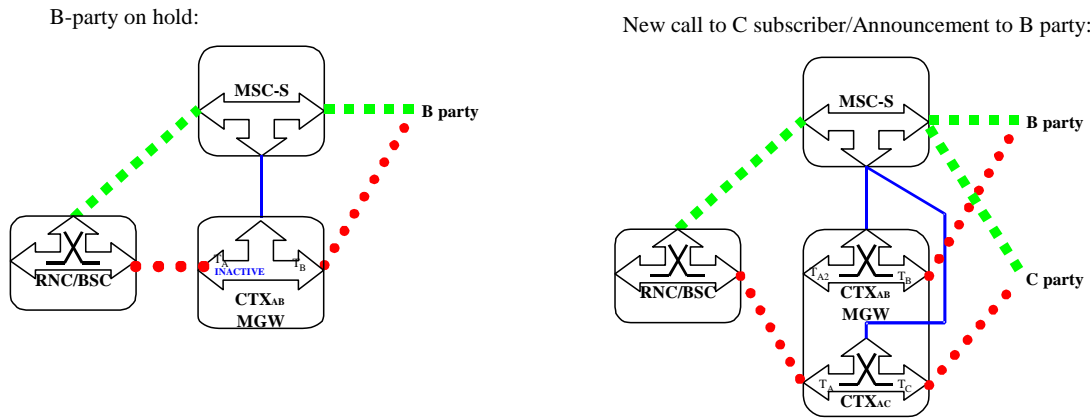
## 13.6.6 Failure handling in MSC server

If any procedure between the MSC server and the MGW has not completed successfully, the MSC server shall reject the hold/retrieve request.

## 13.6.7 Example 1

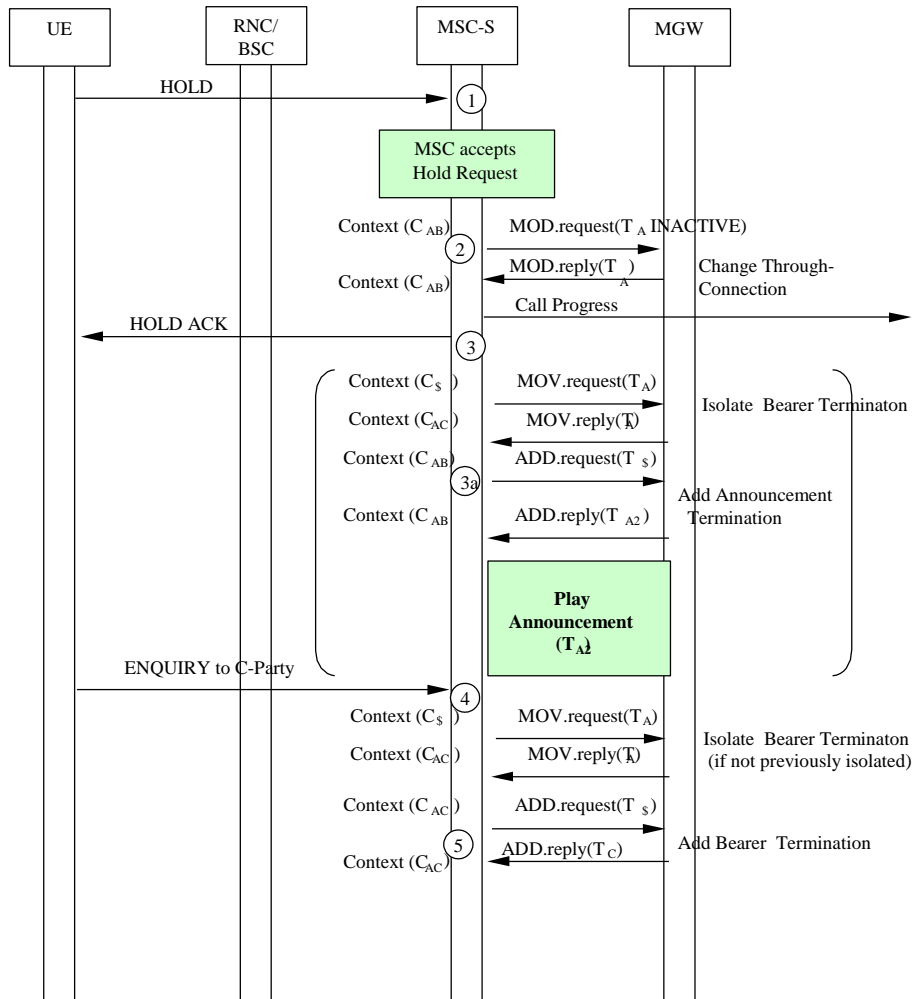
Figure 13.16 shows the network model for the call hold with an establishment of a new call. The "squared" line represents the call control signalling. The "dotted" line represents the bearer control signalling and the bearer. The MSC server isolates the flow connection between the served mobile and the termination in the MGW that is used for the held call. If an announcement is to be played to the held party the MSC Server may seize a new context in the MGW. If a new call is made to C subscriber the MSC server seizes a new context in the MGW if not previously done. The new context is used for the new call and the old context is used for the held call. The bearer termination  $T_A$  is moved with the bearer towards the RNC (served mobile subscriber) and the bearer termination  $T_C$  is used for the bearer towards the succeeding MGW (C-party).

**NOTE:** The main advantage with example 1 is that if B party is connected to a radio access and a handover occurs then the announcement termination is unaffected and therefore there is no break in the announcement. It is also an option to put the B-party on hold using the isolate bearer procedure immediately but this is not shown in this example.



**Figure 13.16: Call hold and establishment of a new call (Network model) example 1**

Figure 13.17 shows the message sequence for example 1 for the call hold procedure. In the example the MSC server requests the MGW to change the through-connection of the bearer so that it will not be through-connected when the hold request is received from the served mobile subscriber (bullet 2 in figure 13.17). Subsequently if an announcement is to be applied then Termination  $T_A$  may be isolated from the held party (bullet 3 in figure 13.17) and a new announcement termination  $T_{A2}$  is added to context  $CTX_{AB}$  and announcement applied to termination  $T_{A2}$  (bullet 3a in figure 13.17). For setting up a new call to the C-party the termination  $T_A$  is moved to a new context if not done previously (bullet 4 in figure 13.17) and a new termination  $T_C$  is reserved (bullet 5 in figure 13.17) and the call shall continue with the appropriate stream mode settings as for a normal call establishment in accordance with Clause 6.1, see figure 6.2.



**Figure 13.17: Hold request (message sequence chart) , example 1**

Figure 13.18 shows the message sequence for example 1 for the retrieval procedure. In the example the MSC server requests the MGW to move the connection of the bearer back to be both-way through-connected (bullet 3 and 4 in figure 13.18) to the held party, after the held party has been disconnected from an optionally applied announcement (bullet 2 in figure 13.18). The MOVE command (Join Bearer termination procedure) is not required (bullet 3 in figure 13.18) if  $T_A$  has not previously been moved into the  $CTX_{AC}$ . The Change Through-Connection is only required if the retrieval occurs prior to any connection to C-party.



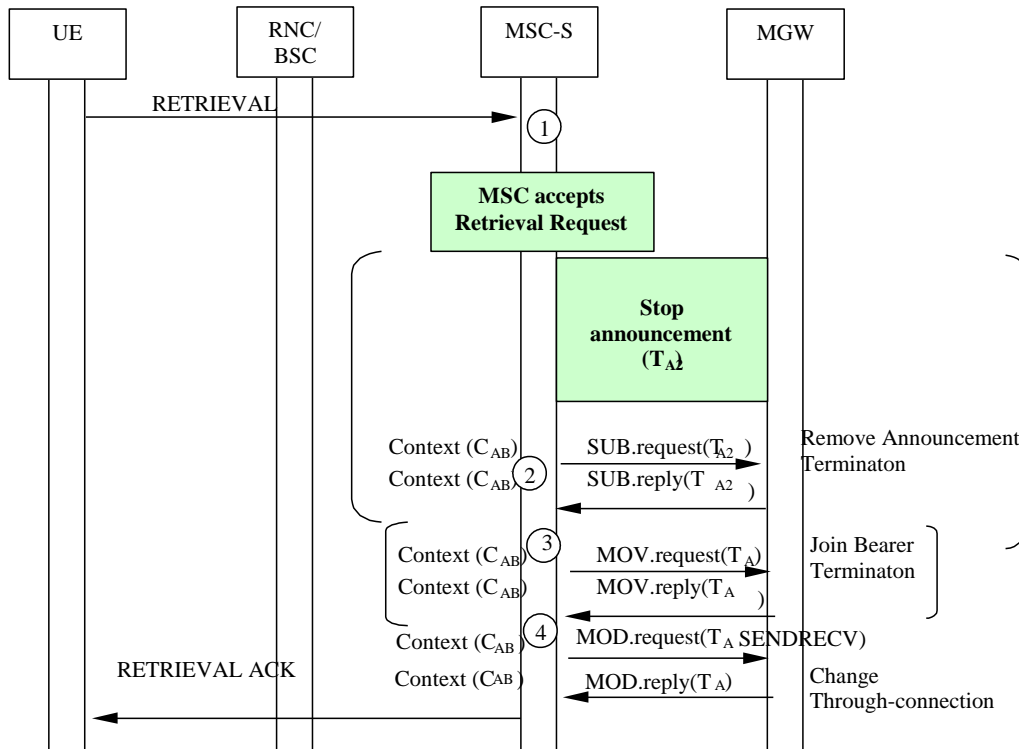
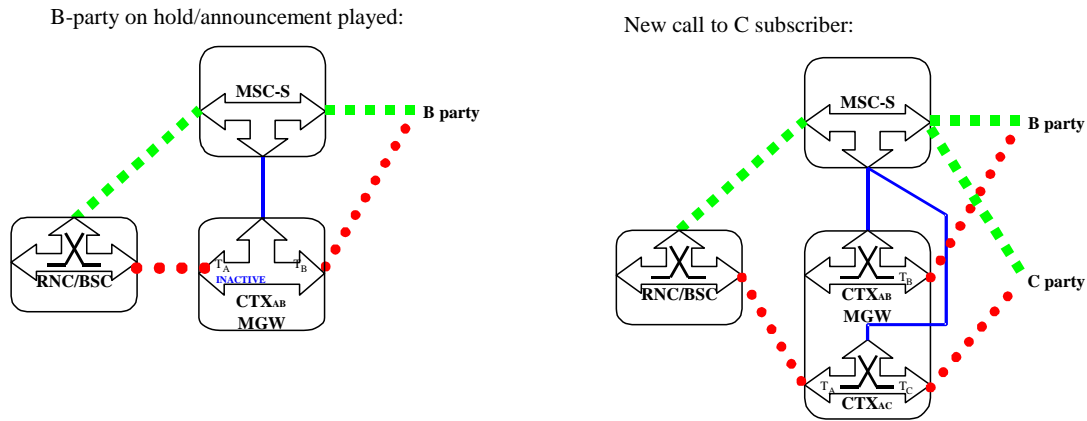


Figure 13.18: Retrieval request (message sequence chart) , example 1

### 13.6.8 Example 2

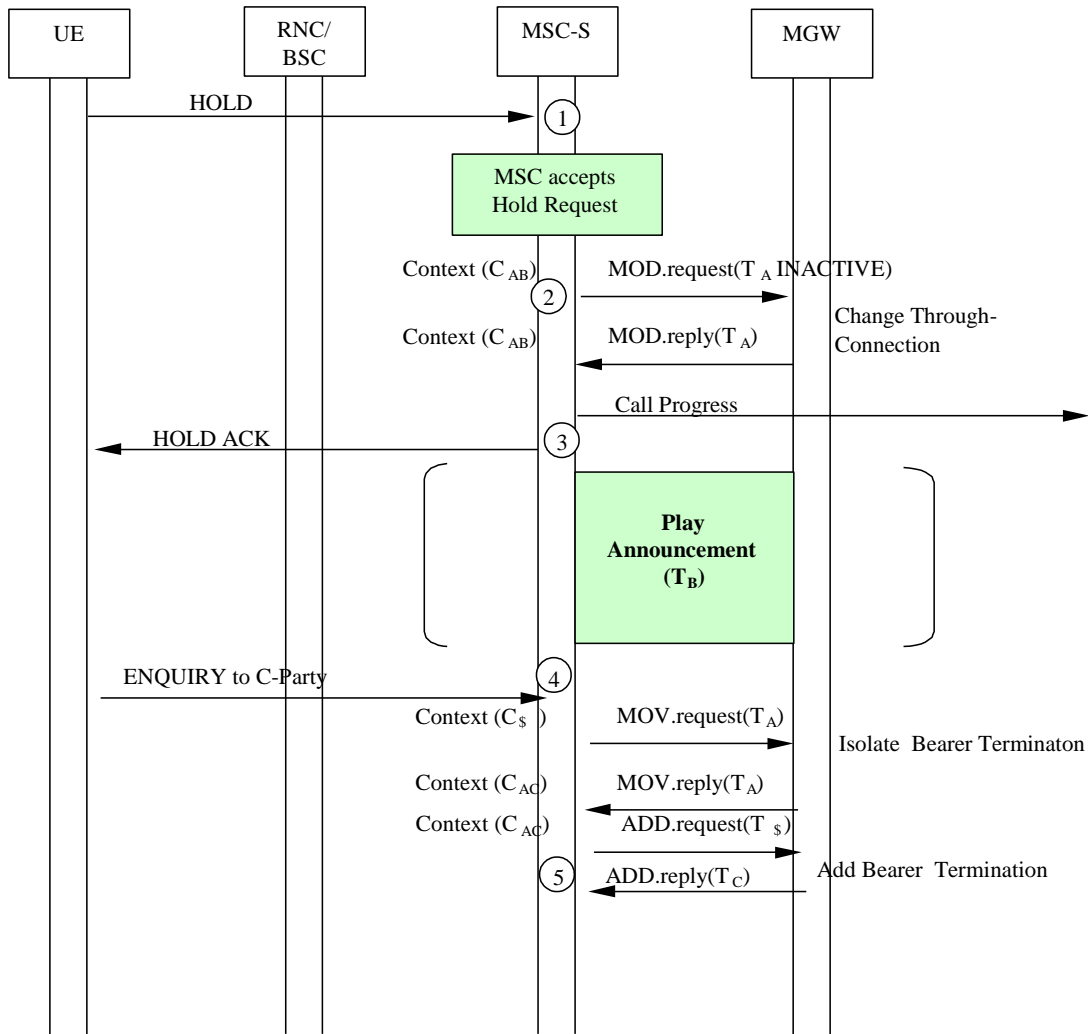
Figure 13.18a shows the network model for the call hold with an establishment of a new call. The "squared" line represents the call control signalling. The "dotted" line represents the bearer control signalling and the bearer. The MSC server isolates the flow connection between the served mobile and the termination in the MGW that is used for the held call. After the request to establish a new call is made the MSC server seizes a new context in the MGW, the new context is used for the new call and the old context is used for the held call. The bearer termination T<sub>A</sub> for the bearer towards the RNC (served mobile subscriber) is moved to this context and the bearer termination T<sub>C</sub> is used for the bearer towards the succeeding MGW (C-party). In this example the announcement is played directly to Termination T<sub>B</sub>.

NOTE: if B party is connected to a radio access and a handover occurs during the announcement then the announcement will be interrupted. It is also possible to put B-party on hold using the isolate bearer termination but if the announcement is still played directly to termination T<sub>B</sub> as proposed by this example and a handover occurs then the problem still arises.



**Figure 13.18a: Call hold and establishment of a new call (Network model) example 2**

Figure 13.18b shows the message sequence for example 2 for the call hold procedure. In the example the MSC server requests the MGW to change the through-connection of the bearer to inactive when the hold request is received from the served mobile subscriber (bullet 2 in figure 13.18b). Subsequently an announcement may be applied to termination T<sub>B</sub> (bullet 3 in figure 13.18b). Then the new call is established via a new context with served mobile subscriber termination T<sub>A</sub> being moved to this new context (bullet 4 in figure 13.18b) and a new termination T<sub>C</sub> is reserved (bullet 5 in figure 13.18b) and the call shall continue with the appropriate stream mode settings as for a normal call establishment in accordance with Clause 6.1, see figure 6.2.



**Figure 13.18b: Hold request (message sequence chart), example 2**

Figure 13.18c shows the message sequence example for the retrieval procedure. In the example the MSC server moves the served mobile subscriber back to the context with termination T<sub>B</sub> and requests the MGW to change the through-connection of the bearer to be both-way through-connected (bullet 3 and 4 in figure 13.18c) after the held party has been disconnected from an optionally applied announcement (bullet 2 in figure 13.18c). The MOVE command (Join Bearer Termination procedure) is not required (bullet 3 in figure 13.18c) if T<sub>A</sub> has not been in the CTX<sub>AC</sub>. The Change Through-Connection is only required if the retrieval occurs prior to any connection to C-party.

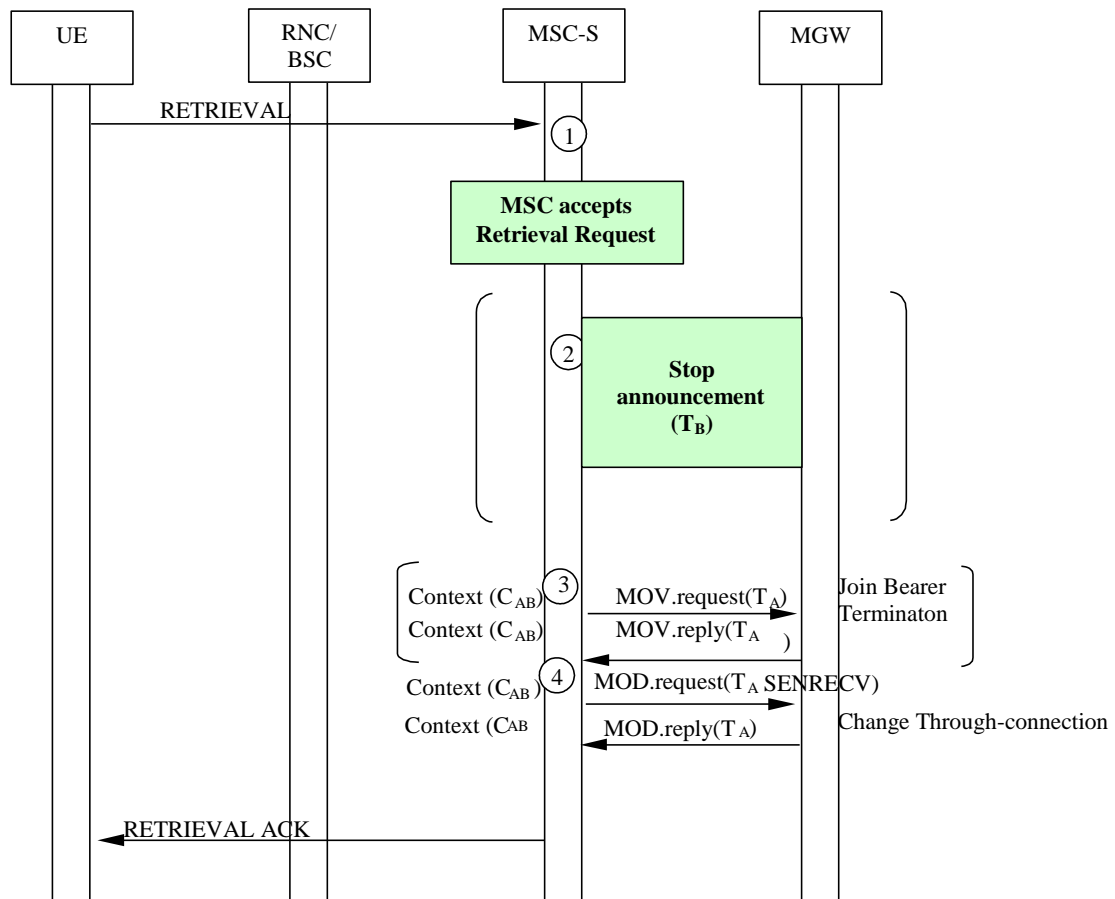


Figure 13.18c: Retrieval request (message sequence chart), example 2

## 13.7 Multiparty (MPTY)

The procedures specified in 3GPP TS 23.084 [14] for the Multi Party supplementary service shall be followed. The following clauses describe the additional requirements for the bearer independent CS core network. If out-of-band transcoder control is applied for the call, it shall be performed in accordance with 3GPP TS 23.153 [3].

### 13.7.1 Beginning the Multi Party call

When the served mobile subscriber invokes a Multi Party service the MSC server selects an MGW that provides the Multi Party bridge capabilities. If the selected MGW is different from the MGW that is used for the active call, the MSC server requests the MGW(s) to connect the bearer terminations of the participants to the selected MGW. The bearer terminations are connected together.

### 13.7.2 Managing an active Multi Party call

When the served mobile subscriber puts the Multi Party call on hold the MSC server requests the MGW to interrupt the connection between the served mobile subscriber and the Multi Party bridge.

When the served mobile subscriber retrieves a held Multi Party call the MSC server requests the MGW to re-establish the connection between the served mobile subscriber and the Multi Party bridge.

When the served mobile subscriber requests private communication with one of the remote parties (e.g. B-party), the MSC server shall request the MGW to interrupt the connection between the served mobile subscriber and the Multi Party bridge, and connection between the remote B party and the Multi Party bridge. The MSC server requests the

MGW to connect the bearer termination of the served mobile subscriber to the bearer termination of the remote party (or vice versa) within a same context.

### 13.7.3 Disconnect

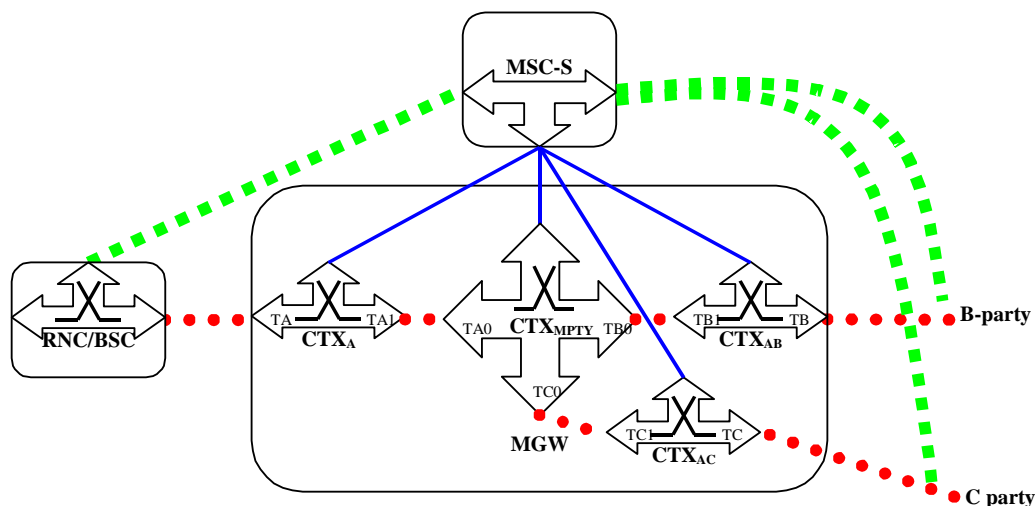
If a remote party is disconnected while other parties still remain the call towards the remote party is disconnected as described in the clause for call clearing.

### 13.7.4 Failure handling in MSC server

If resources for the Multi Party service cannot be allocated in any of the MGW resources assigned to the MSC server, then the MSC server shall reject the MPTY request.

### 13.7.5 Example 1 – Multiparty call establishment

Figure 13.19 shows the network model for multi party call. The "squared" line represents the call control signalling. The "dotted" line represents the bearer control signalling and the bearer. Note that for a TDM access there is no separation between the call and bearer control signalling. In the following example it is assumed that each party participating in the Multi Party conference is handled in a separate context representing the call leg between the Multi Party bridge and the Multi Party participant. The Multi Party bridge itself is handled in a separate context. This separation to several contexts is done in order to simplify interactions with other functionality, such as handover, even though other implementation options are not excluded.



**Figure 13.19: Multi Party call (Network model)**

For the purposes of the information flow diagrams it is assumed that there are only two remote parties. Party A is the subscriber controlling the Multi Party service (served mobile subscriber). Party B is the held party and party C is the active party.

It is assumed that the Multi Party bridge is located in the MGW that has been selected for the served mobile subscriber.

Figure 13.20 shows the message sequence example for the beginning of multi party call. When the served mobile subscriber invokes a Multi Party service the MSC server requests the MGW to create a separate context for the Multi Party bridge. The MSC server seizes a bearer termination for each party in that context. In addition, each call leg is represented by a separate context. Therefore the parties in the active call will be split in separate contexts. The MSC server requests the MGW to create a new context and to move the bearer termination for the served mobile subscriber from the active call context to the new context. To connect the parties to the Multi Party bridge the MSC server requests the MGW to establish internal Nb connections between the bearer terminations in the Multi Party bridge context and the call leg contexts, using the standard external bearer setup procedures. The held party is informed about the retrieval of the held call, and the both remote parties are informed about the multi party call establishment.

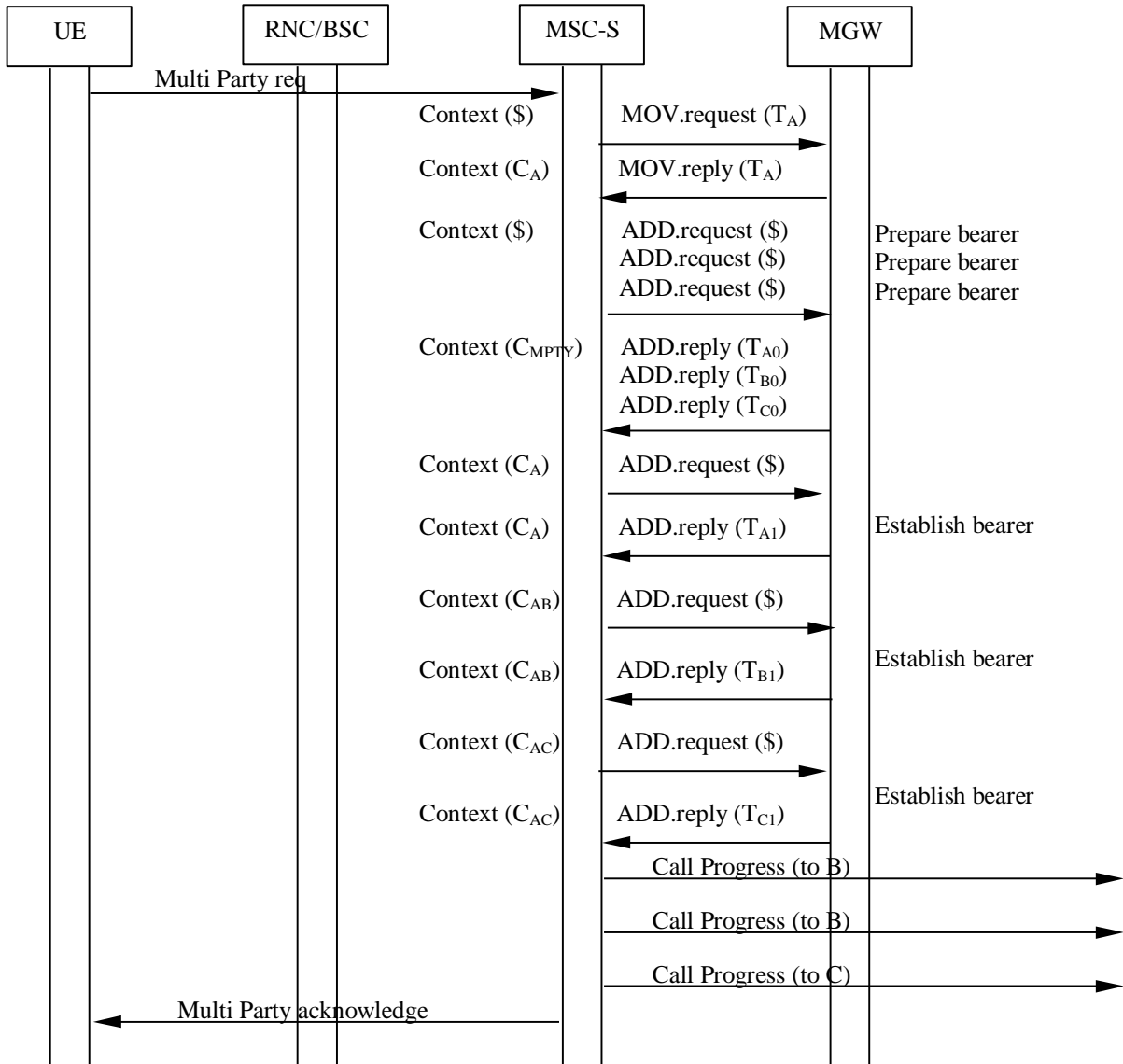


Figure 13.20: Information flow for multi party call, internal ATM bearer (message sequence chart)

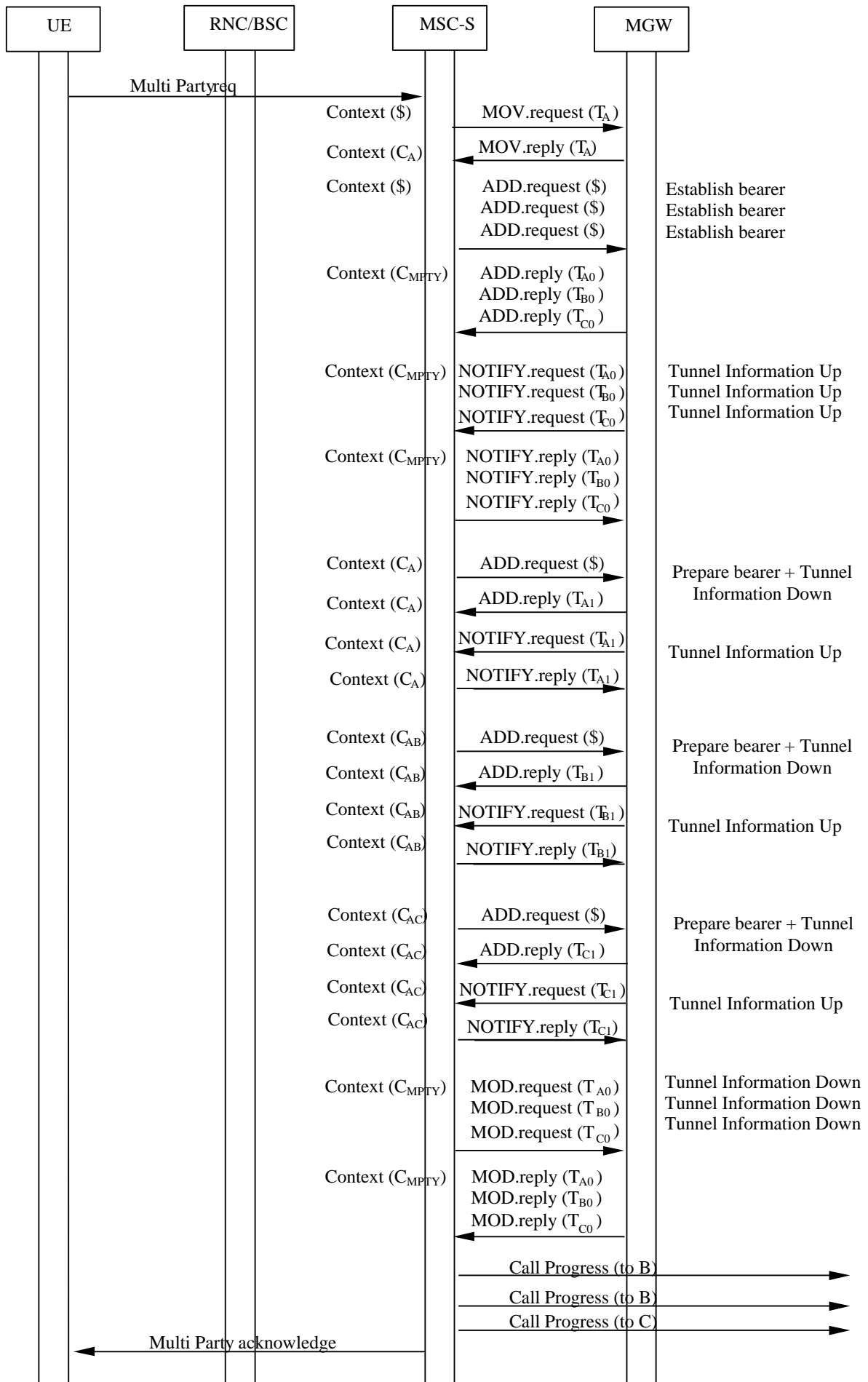


Figure 13.20a: Information flow for multi party call, internal IP bearer (message sequence chart)

### 13.7.6 Example 2 – Private call establishment during multiparty call

Figure 13.20b shows the network model for private call. The "squared" line represents the call control signalling. The "dotted" line represents the bearer control signalling and the bearer. Note that for a TDM access there is no separation between the call and bearer control signalling.

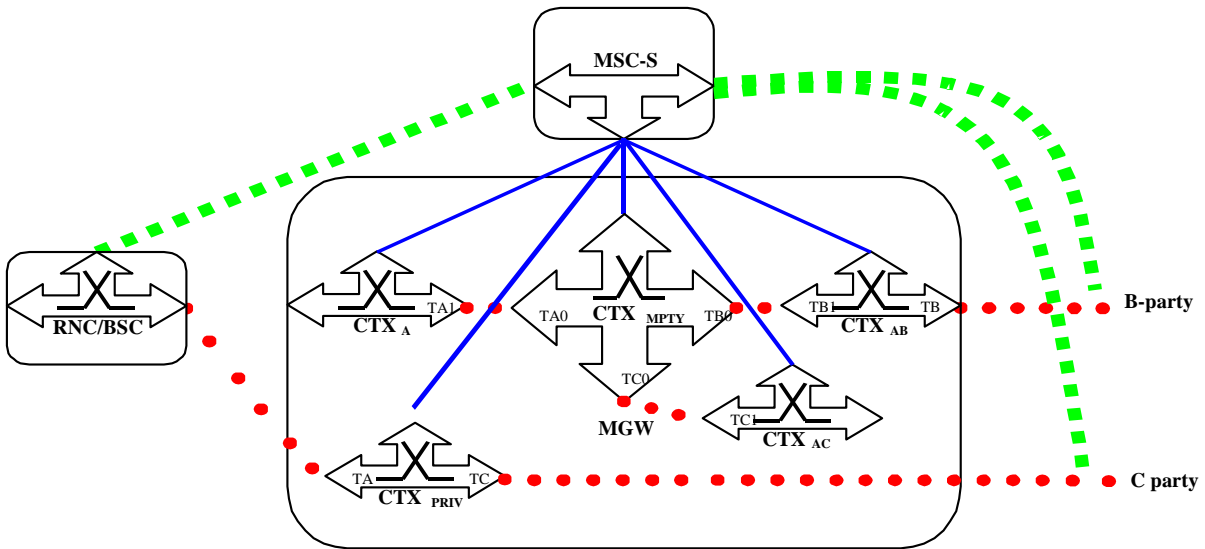


Figure 13.20b: Private call (Network model)

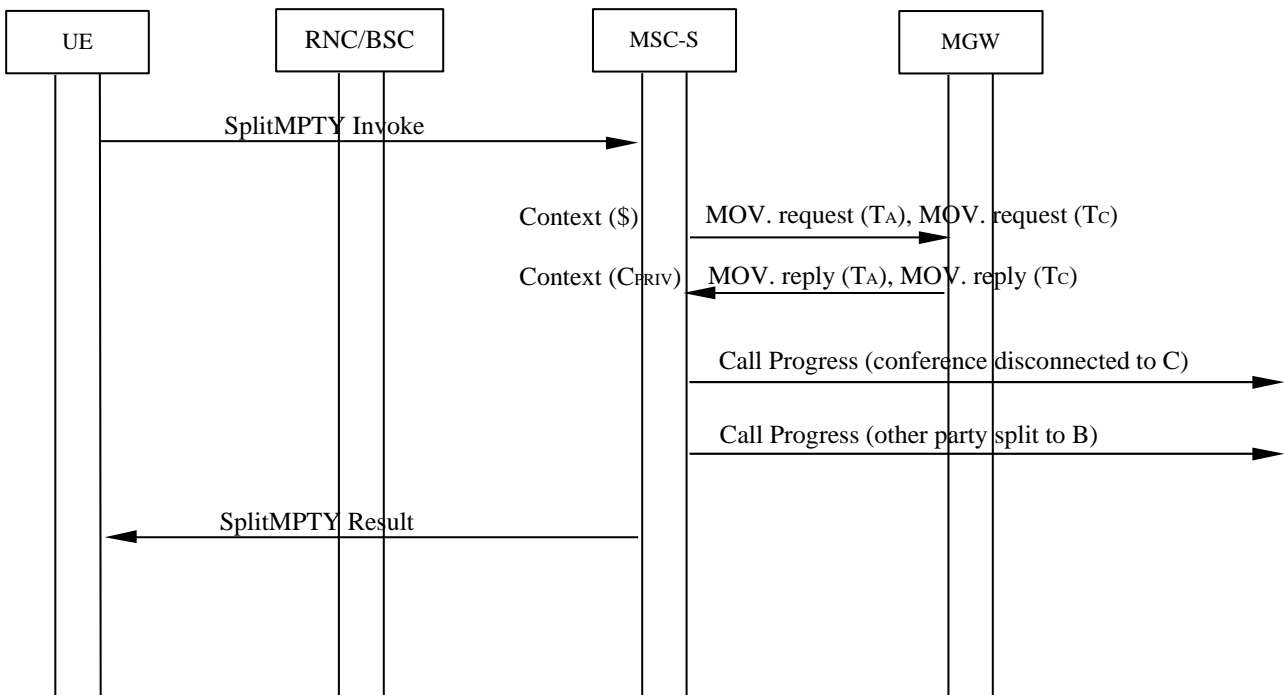


Figure 13.20c: Information flow for private call (message sequence chart)

NOTE: The two MOVE commands may be sent in different transactions.

For the purposes of the information flow diagrams it is assumed that there are only two remote parties and the private call is established between the served mobile subscriber (Party A) and the remote C-party.

Figure 13.20c shows the message sequence example for the beginning of private communication between the served mobile subscriber and the remote parties (e.g. C-party).



## 13.8 Closed User Group (CUG)

No impact.

## 13.9 Advice of Charge (AoC)

No impact.

## 13.10 User-to-User Signalling (UUS)

No impact.

## 13.11 Call Barring Services

### 13.11.1 Barring of outgoing calls

No impact.

### 13.11.2 Barring of incoming calls other than Anonymous Call Rejection

No impact.

### 13.11.3 Anonymous Call Rejection (ACR)

#### 13.11.3.1 General

The Anonymous Call Rejection service is described in 3GPP TS 23.088 [46].

#### 13.11.3.2 Anonymous Call Rejection by the GMSC

If the incoming call to the mobile station is determined to be barred by the Anonymous Call Rejection service, the call shall be barred. Otherwise the call shall be delivered as described in clause 6, Call Establishment.

If the call is to be rejected due to ACR the GMSC shall seize a MGW to connect the call to a recorded announcement as for existing barring procedures requiring a tone or announcement.

The GMSC shall include Cause No. 24 – Call rejected due to feature at destination in the CPG or ACM and then the GMSC server provides the MGW with the announcement identification and requests the MGW to notify the announcement completion using the Play Announcement procedure as described in subclause 14.6.

After the announcement has been completed the GMSC server initiates the call release as described in the clause 7, with the cause 31 (normal, unspecified).

## 13.12 Explicit Call Transfer (ECT)

The procedures specified in 3GPP TS 23.091 [15] for the Explicit Call Transfer supplementary service shall be followed. The following clauses describe the additional requirements for the bearer independent CS core network.

Party A is the subscriber controlling the Explicit Call Transfer Call (served mobile subscriber). Party B is the first remote called party (held party). Party C is the second remote called party.

### 13.12.1 Connection of remote parties

If the result of the ECT checks is successful the MSC server will order the MGW to connect the bearer termination of the C-party to the bearer termination of the B-party (bullet 1 in figure 13.24 or in figure 13.21). As a result of this action the held party will be retrieved.

If the call towards the C-party has not been answered, the MSC server requests the MGW to both-way through-connect the bearer termination towards the C-party.

### 13.12.2 IU/A-interface release

The served party is disconnected after a successful transfer request. The call towards the served mobile subscriber shall be released as described in the clause for call clearing.

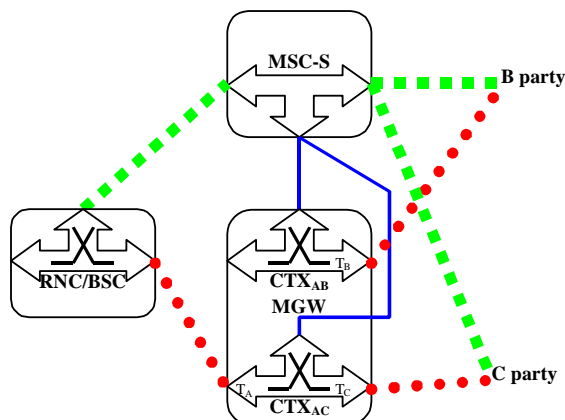
### 13.12.3 Failure handling in MSC server

If the bearer terminations for the remote parties can not be connected successfully, the MSC server shall reject the ECT request.

### 13.12.4 Example

Figure 13.23 shows the network model for call explicit call transfer. The "squared" line represents the call control signalling. The "dotted" line represents the bearer control signalling and the bearer. Note that for a TDM access case there is no separation of call and bearer control signalling. The MSC server moves the bearer terminations of the remote parties in the same context and removes the bearer termination for the served mobile subscriber. The bearer termination  $T_A$  is used for the bearer towards the served mobile subscriber, the bearer termination  $T_B$  is used for the bearer towards the B-party and the bearer termination  $T_C$  is used for the bearer towards the C-party.

Before ECT request:



After ECT:

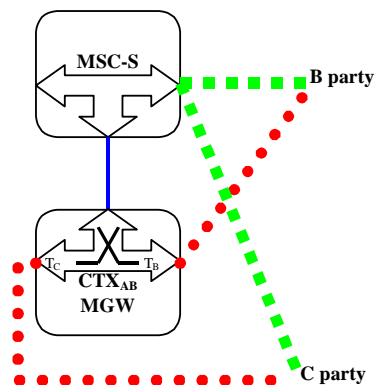


Figure 13.23: ECT (Network model)

Figure 13.24 shows the message sequence example for the explicit call transfer when both calls have been answered. In the example the MSC server requests the MGW to move the bearer termination for the C-party in the active call to the same context which contains the bearer termination for the B-party. The held party is informed about the retrieval of the held call. Both the remote parties are informed about the call transfer. After the move the MSC server releases the call and the bearer connection towards the served mobile subscriber and requests the MGW to remove the bearer termination for the served mobile subscriber.

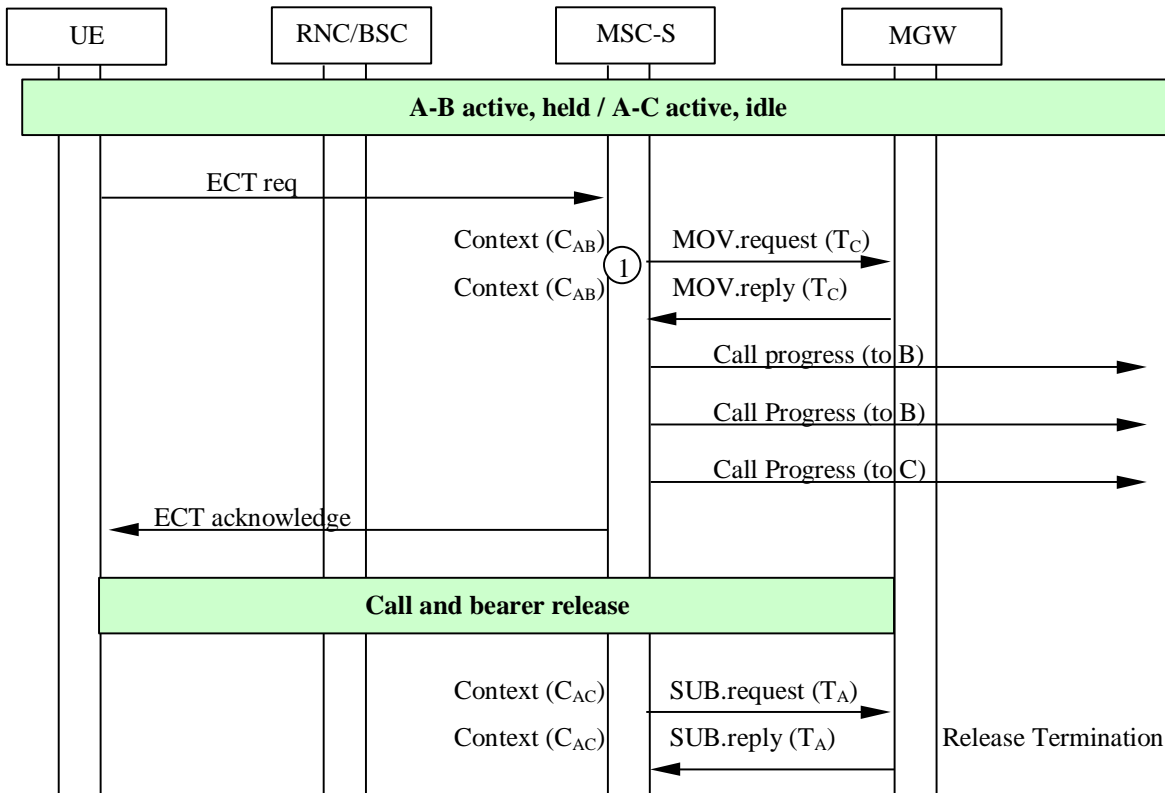


Figure 13.24: Explicit call transfer; both calls answered (message sequence chart)

Figure 13.25 shows the message sequence example for the explicit call transfer when one call is answered and the other call has been delivered. In the example the MSC server requests the MGW to move the bearer termination for the C-party in the active call to the same context which contains the bearer termination for the B-party. The held party is informed about the retrieval of the held call. Both the remote parties are informed about the call transfer. After the move the MSC server releases the call and the bearer connection towards the served mobile subscriber and requests the MGW to remove the bearer termination for the served mobile subscriber. The B-party is informed about the active call when the C-party sends the Answer indication.

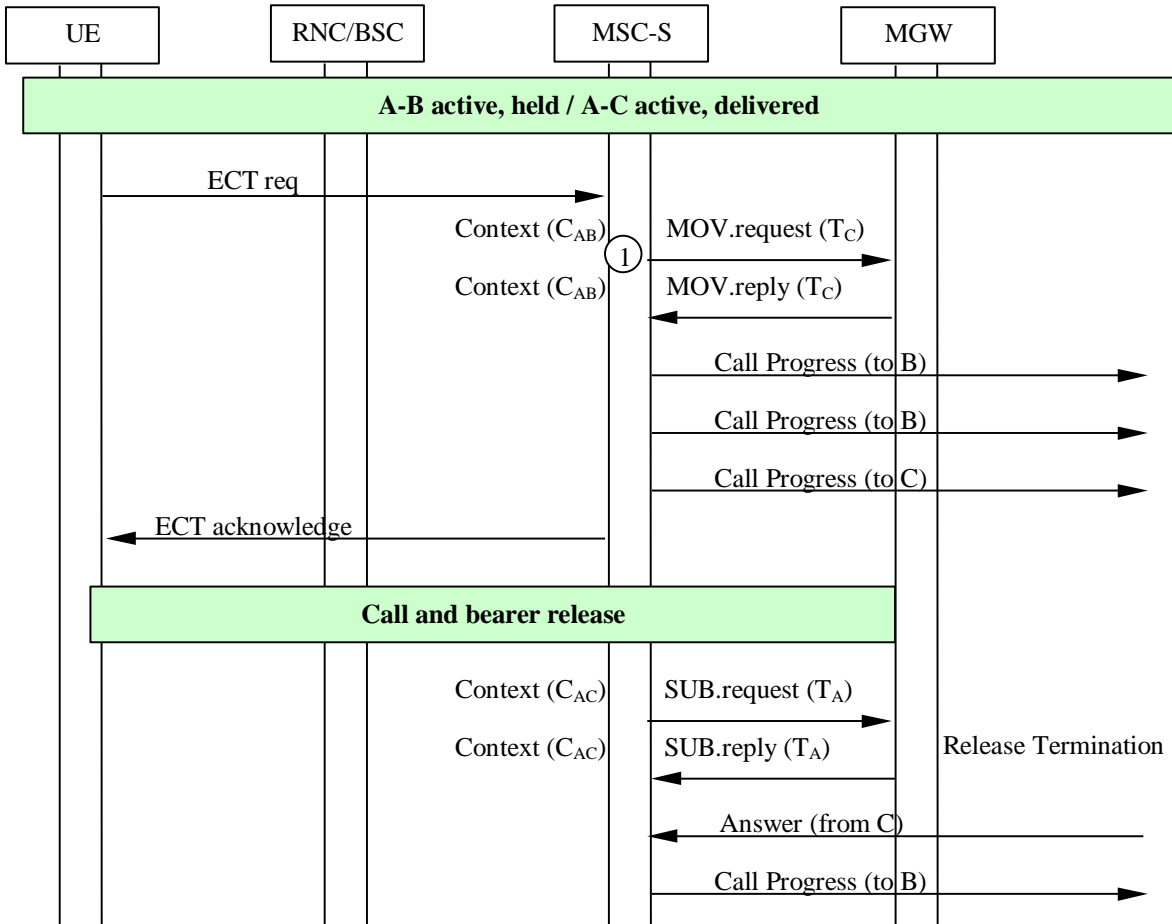


Figure 13.25: Explicit call transfer; other call delivered (message sequence chart)

### 13.13 Completion of Calls to Busy Subscriber (CCBS)

The procedures specified in 3GPP TS 23.093 [16] for the Completion of Calls to Busy Subscriber supplementary service and 3GPP TS 23.108 [18] shall be followed. The following clauses describe the additional requirements for the bearer independent CS core network.

#### 13.13.1 Clearing when tones/announcements are provided to the calling subscriber

If an announcement is to be provided for the purpose of notifying the subscriber that CCBS activation is possible, the MSC server shall select an MGW. The MGW performs the traffic channel assignment if the bearer termination has not been through-connected (as described in clause 6.1 for the basic mobile originating call). The MGW through-connects the bearer before providing the in-band information. The MSC server requests the MGW to play an announcement/tone using the Play Announcement or Send Tone procedure. When the announcement has completed the MGW notifies the MSC server (using the Announcement Completed procedure as described in clause 14.6) that the announcement is complete.

Otherwise the MSC server handles the call clearing as described in clause 7.

#### 13.13.2 Network initiated mobile originated call

The call is established as described in clause 6.1 for basic mobile originating call.

### 13.13.2.1 Early Traffic Channel Assignment

Within CCBS there is an option for a CCBS call to establish a bearer before setup in state "CC-establishment confirmed". In this case the MSC server shall check whether an access bearer assignment modification has to be performed after receiving the setup message from UE.

#### 13.13.2.1.1 Example

For the network model, please refer to figure 6.1.

Figure 13.26 shows the message sequence chart for the network initiated mobile originating call using the option assignment after A and B party alerting. In the following, the case with backward bearer establishment is considered.

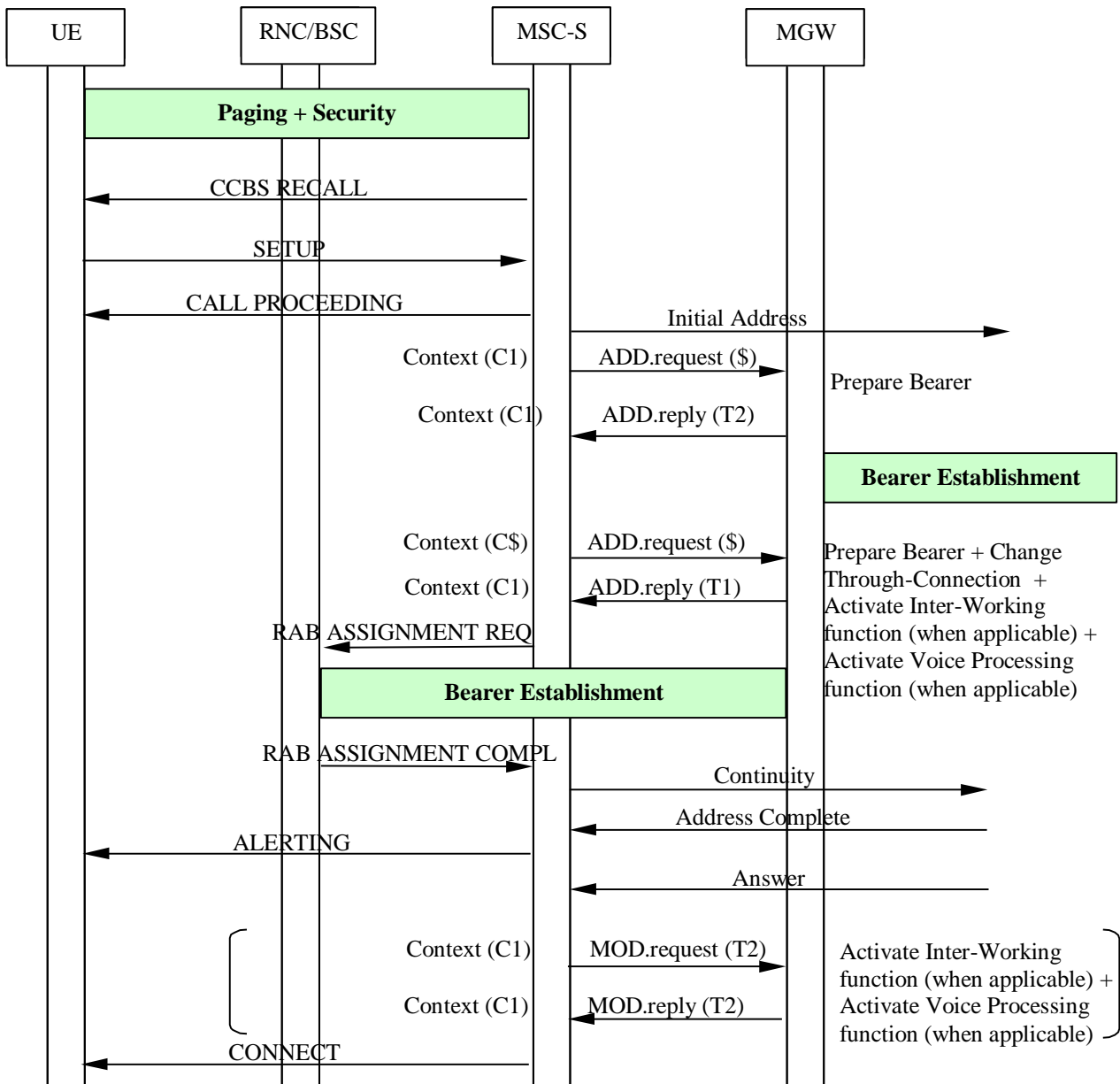


Figure 13.26: Network initiated mobile originating call establishment with assignment after A and B party alerting (message sequence chart)

### 13.13.3 CCBS Information conveyed by Call Signalling

For CCBS, application specific information needs to be conveyed via the call signalling. Specific details of the CCBS information are described in 3GPP TS 23.093 [16].

## 13.14 Multiple Subscriber Profile (MSP)

No impact.

## 13.15 Multicall

The procedures specified in 3GPP TS 23.135 [17] for the Multicall supplementary service shall be followed. The following clauses describe the additional requirements for the bearer independent CS core network. If out-of-band transcoder control is applied for a speech call, it shall be performed in accordance with 3GPP TS 23.153 [3].

### 13.15.1 Mobile Originating

When the UE is in active mode and it makes a request for the multicall function on a new traffic channel, call and bearer establishment shall be as described for mobile originating call.

When the UE is in active mode and it makes a request for the multicall function using an existing traffic channel, call and bearer establishment shall be as described for call hold function. An active call will be placed on hold and the additional originating call will be initiated.

### 13.15.2 Mobile Terminating

When the UE is in active mode and it makes a request for the multicall function on a new traffic channel, call and bearer establishment shall be as described for mobile terminating call. Access bearer assignment shall occur either after a Call Confirmed or a Connect message is received from the UE.

When the UE is in active mode and it makes a request for the multicall function using an existing traffic channel, call and bearer establishment shall be as described for call hold function. An active call will be placed on hold and the additional terminating call will be initiated.

## 13.16 Calling Name Presentation (CNAP)

No impact.

## 13.17 Alternate Speech/Fax

The procedures for facsimile group 3 transparent/non-transparent shall be followed in accordance with 3GPP TS 43.045 [24] and 3GPP TS 23.146 [25]. The following clauses describe the additional requirements for the bearer independent CS core network. If out-of-band transcoder control is applied for a speech call, it shall be performed in accordance with 3GPP TS 23.153 [3].

Call and bearer establishment shall be handled as described in the Call Establishment clause. In order to change from speech to fax (or vice versa), the MSC server shall modify the access bearer as described in subclause 13.18.1.

If the MGW responds with an error to any of the procedures initiated by the MSC server, or the MSC server receives a Bearer Failure procedure from the MGW, the MSC server may either clear the call or reject the change from speech to fax (or vice versa).

After this possible modification, the MGW shall seize an interworking function if a PLMN Bearer Capability [4] has been supplied to the access side bearer termination. When the MSC server receives an answer indication, it shall request activation of the interworking function using the Activate Interworking Function procedure.

## 13.18 Modification of the Access Bearer

### 13.18.1 Modification of Bearer Characteristics

The modification of the access bearer is possible during a call establishment and during an active call. If the MSC server needs to modify the access bearer, the existing bearer termination in the MGW is modified or a new access side bearer termination is created. The modification of the access bearer shall be performed in accordance with 3GPP TS 25.413 [26] or 3GPP TS 48.008 [27].

#### 13.18.1.1 Iu mode

If the link characteristics for the existing access bearer need to be changed and the MSC server previously received a notification from the MGW that modification of link characteristics of the current transport connection is supported [refer to 26], the MSC server shall use the Modify Bearer Characteristics procedure to provide the MGW with the new bearer characteristics for the existing access side bearer termination. After the MGW has replied, the MSC server shall initiate the access bearer modification towards RAN.

If the MSC server has not previously received a notification from the MGW that modification of existing link characteristics is supported, the MSC server shall use the Prepare Bearer procedure to request the MGW to add a new context and a new access side bearer termination, and to provide a bearer address and a binding reference. After the MGW has replied, the MSC server shall initiate the access bearer modification towards RAN using the provided bearer address and the binding reference. Upon successful access bearer modification, the MSC server shall connect the new access side bearer termination to the old context and release the old access side bearer termination.

If the user plane mode of the modified access bearer is "Support Mode", the Iu UP will also be re-initialised as defined in [20].

#### 13.18.1.2 A/Gb mode

The MSC server shall use the Modify Bearer Characteristics procedure for A interface TDM termination and may use the Modify Bearer Characteristics procedure or the Configure RTP Connection procedure for AoIP termination to the MGW to provide the new bearer characteristics for the existing access side bearer termination. After the MGW has replied, the MSC server shall initiate the access bearer modification towards GERAN.

### 13.18.2 IWF Protocol Change

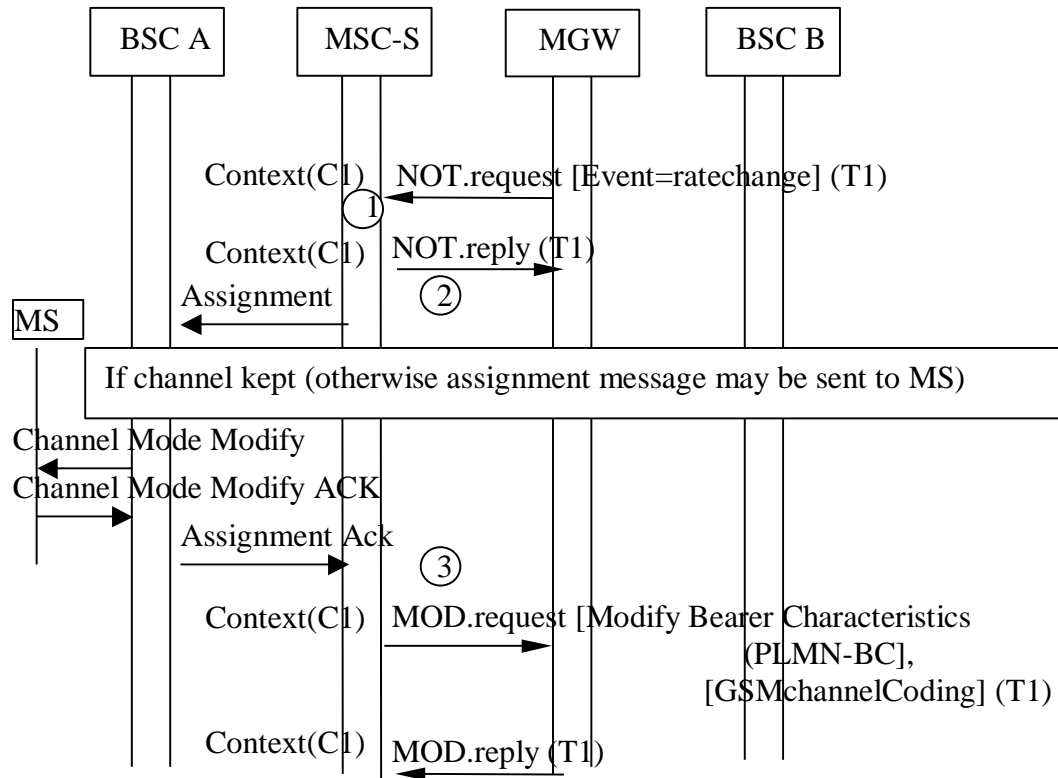
If the MSC server has requested indication on IWF protocol events, the MGW informs the MSC server about changes related to IWF protocol, using the Protocol Negotiation Result and Rate Change procedures.

For AoIP terminations there shall be no change to the AoIP Transport Layer Address (MGW) and AoIP Transport Layer Address (BSS) for Rate Changes in data calls. Instead the MSC shall include the previously returned Local Connection Address in any subsequent Assignment request to the BSS.

## 13.19 GSM Fax

The procedures for facsimile group 3 transparent service toward a GSM BSS shall be followed in accordance with 3GPP TS 43.045 [24]. The following clauses describe the additional requirements for the bearer independent CS core network.

Call and bearer establishment shall be handled as described in the Call Establishment clause with the addition that the Rate Change Event Notification shall be requested. If the MGW detects a mismatch between the radio channel rate to the facsimile transmission speed then it shall indicate this to the MSC server by use of the rate change procedure. The MSC server shall initiate a new Assignment towards the GSM RAN and if successful modify the PLMN Bearer Capability and GSM Channel Coding at the associated access bearer termination using the Modify Bearer Characteristics procedure as described in 16.2.41 to signal to the MGW that fax transmission can continue. The sequence is shown in Figure 13.19/1.



**Figure 13.19/1: GSM access Channel Mode Modify message**

For AoIP terminations the Configure RTP Connection Point Procedure may be used instead of the Modify Bearer Characteristics procedure.

## 13.20 Voice group call service (VGCS), Voice broadcast service (VBS)

### 13.20.1 Beginning the Voice group call

The procedures specified in 3GPP TS 43.068 [39] for the Voice group call service shall be followed. For a Voice broadcast call the procedures in 3GPP TS 43.069 [40] shall be followed. When the served mobile subscriber invokes a Voice group call service the MSC server selects an MGW that provides the conference bridge capabilities with enhancements to support Voice group calls. The MSC server shall estimate the size of the Conference terminations needed for the VGCS call from the data retrieved from GCR and reserves the requested number of Conference terminations for that call. The number of needed conference terminations is provided within prepare bearer procedure.

### 13.20.2 Talker change in Voice group call (1 channel model)

If the MSC server decides that the talker shall use the uplink associated to the downlink of the ASCII broadcast (common group call) channel (1channel model, see 3GPP TS 43.068 [39]), the talkers speech is transferred via the uplink channel of the ASCII broadcast channel of the cell. The stream arrives within the MGW on the termination of the traffic channel serving the cell or BSS (enhanced A-interface) and is transferred to the conference function where the summarized conference signal is calculated. The resulting stream is then transferred to all conference terminations. The normal behaviour of a conference bridge is to subtract for each conference member its own speech (incoming stream) from the summarized signal otherwise it hears itself (outgoing stream). Therefore the Talker context need to be modified by adding a new termination to the context which is connected to the listener context (see figure 13.20.5/3 and 13.20.5/5). The topology within the talker context is set oneway from uplink of the ASCII broadcast channel in direction to Conference bridge (old termination of the talker context) and the topology is set to Oneway from the new added termination towards the termination connected to the downlink of the ASCII broadcast channel. This is performed using establish bearer procedure and change flowdirection. To avoid, that the talker hear himself, the UE internally switch off the loudspeaker (muting/unmuting functionality, 3GPP TS 43.068 [39]) on request of the MSC server.



### 13.20.3 Disconnect

A dispatcher can leave or reenter the call at any time without any influence of the ongoing call. Only the dispatcher is disconnected as described in the clause for call clearing (see 3GPP TS 43.068 [39], 3GPP TS 43.069 [40]).

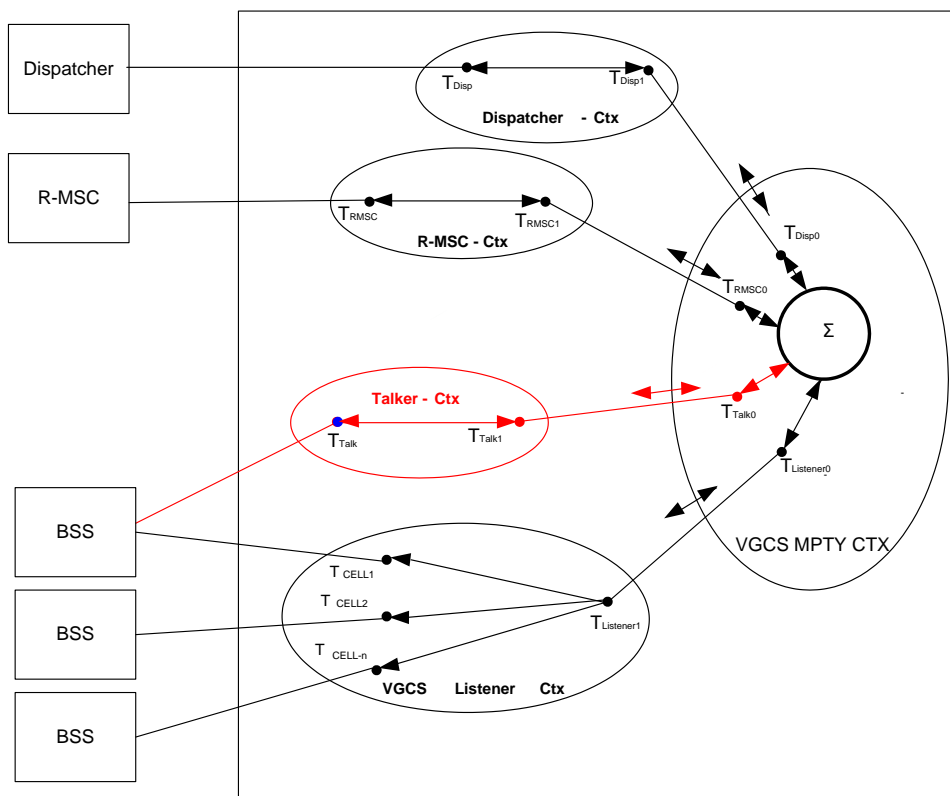
The Voice group call can only be released by an authorised subscriber (see 3GPP TS 43.068 [39], 3GPP TS 43.069 [40]). If an authorised subscriber triggers the release of the group call all other parties are disconnected as described in the clause for call clearing.

### 13.20.4 Failure handling in MSC server

If resources for the Voice group call service cannot be allocated in any of the MGW resources assigned to the MSC server (e.g. not enough conference terminations are available with cause "510 - Insufficient resources"), then the MSC server shall reject the VGCS request.

### 13.20.5 Example

Figure 13.20.5/1 shows a possible network model of an anchor MSC for a voice group call when the Talker is on the dedicated channel. At call setup Dispatchers, R-MSC and the talker can be seen as a multi party call. The listeners are connected oneway in their context (bullet 1 and 2 in figure 13.20.5/2). In the example every kind of termination is shown in its own context.



**Figure 13.20.5/1: VGCS call (termination overview for talker on dedicated channel)**

If the talker is on a dedicated channel, the talker context contains two terminations which are connected bothway a termination overview is given in figure 13.20.5/1.

Figure 13.20.5/2 shows the message flow establishment of a VGCS call with two cells and the talker is located in cell1 when the Talker is on the dedicated channel. To connect the parties to the VGCS Multi Party Bridge the MSC server requests the MGW to establish internal Nb connections between the bearer terminations in the VGCS Multi Party bridge context and the call leg contexts, using the standard external bearer setup procedures. VGCS call acknowledge (bullet 3 in figure13.20.5/2) should be send after the ASCII broadcast channel is established in the cell where the talker is located (see 3GPP TS 43.068 [39], 3GPP TS 43.069 [40]).

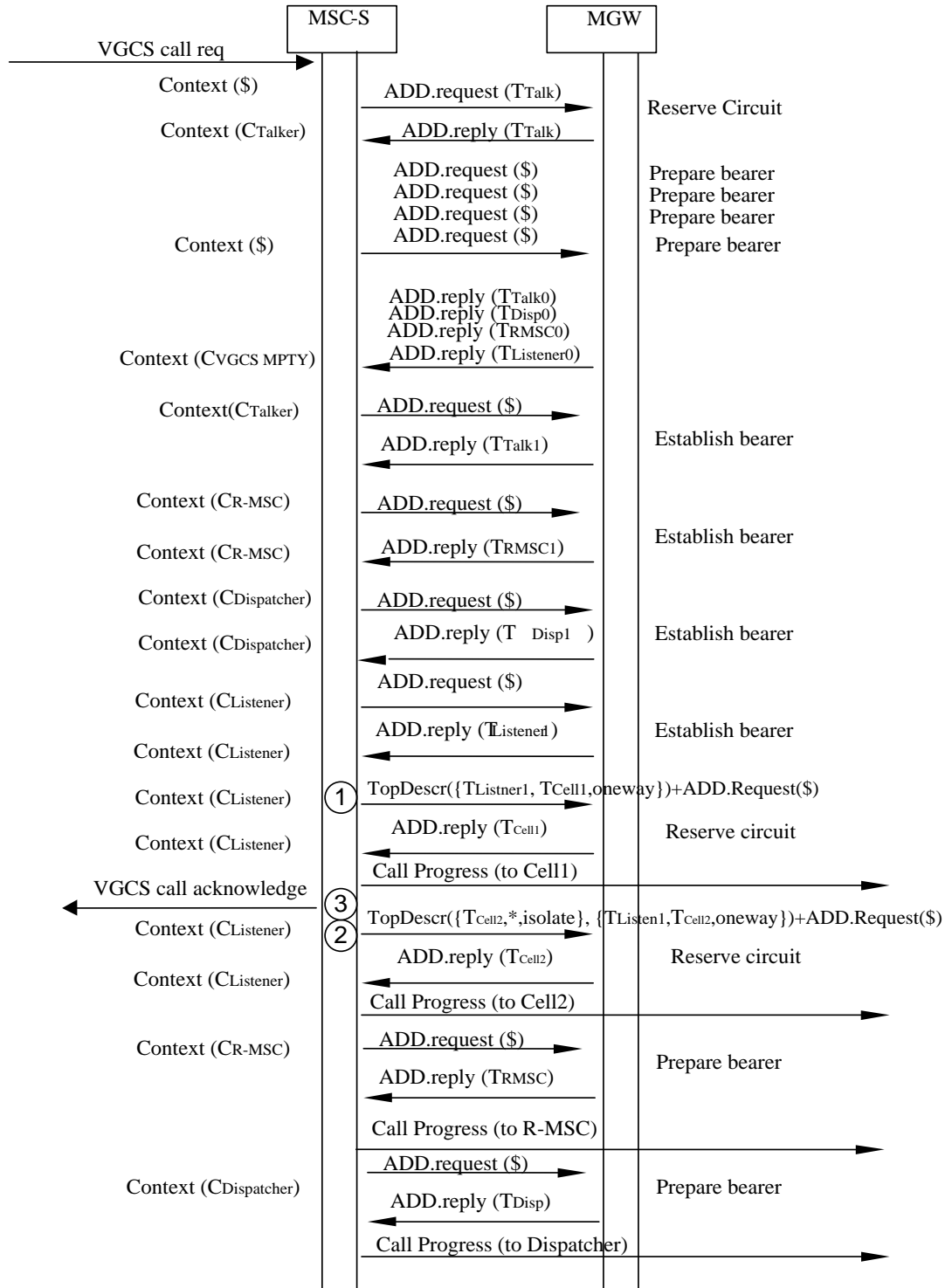
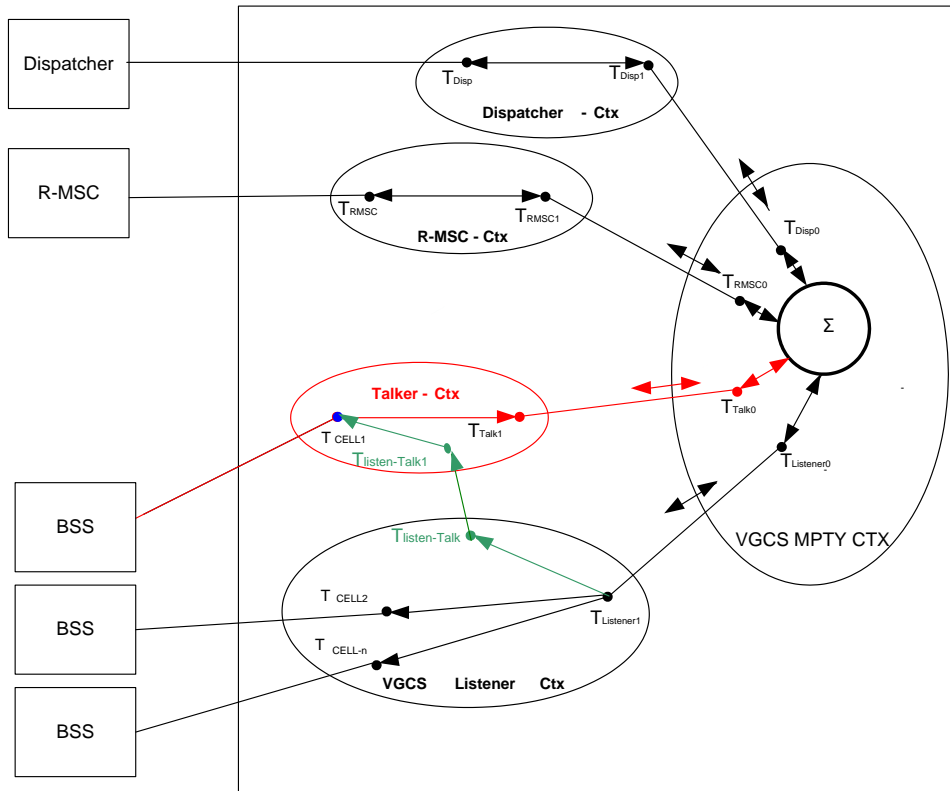


Figure 13.20.5/2: Talker on dedicated channel (Message sequence chart)

Figure 13.20.5/3 shows a possible network model of an anchor MSC for a voice group call when the Talker is on one channel mode.



**Figure 13.20.5/3: VGCS call (termination overview for Talker on one channel model)**

Figure 13.20.5/4 shows the message flow establishment of a VGCS call with two cells and the talker is located in cell1 when the Talker is on one channel mode.

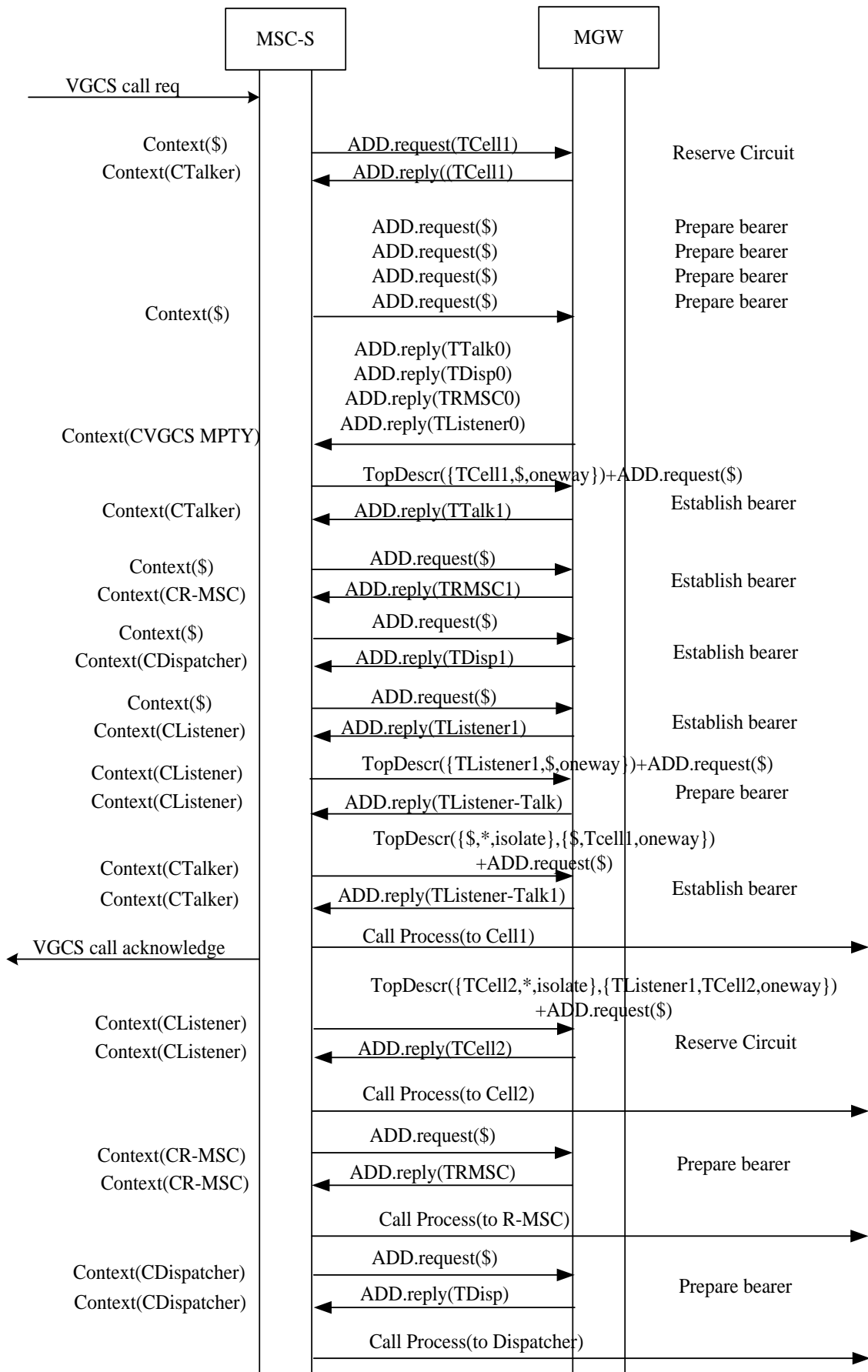


Figure 13.20.5/4: Talker on one channel mode (Message sequence chart)



The gsmSSF uses the capabilities of the (G)MSC server and the MGW to play announcements or send tones to the server.

NOTE 1: In the subsequent figures within clause 14.1, the "Connect To Resource" scenario is used. However the other CAMEL Intelligent Peripheral (IP) scenarios are not intended to be excluded. No impacts are identified when applying these other CAMEL scenarios.

NOTE 2: The gsmSRF functionality may be deployed within the MSC server, and either the current serving MGW or any MGW resource under the control of the current MSC server.

### 14.1.1 Play Announcement/Send Tone

The playing of an announcement or sending of a tone shall be performed in accordance with 3GPP TS 23.078 [10]. It is assumed that the MGW selected for the call has the capabilities to provide announcements and tones.

When the gsmSCF requests the gsmSRF to play a specified announcement or tone, the gsmSRF orders the MGW to play the announcement or tone as described in clause 14.6.

After the gsmSRF has received the announcement or tone completed notification from its MGW, it reports the announcement or tone completion to the gsmSCF.

If the gsmSCF requests the gsmSRF to cancel the earlier started announcement or tone, the gsmSRF orders the MGW to stop playing the announcement or tone as described in clause 14.6.

#### 14.1.1.1 Example of playing announcement by the gsmSRF

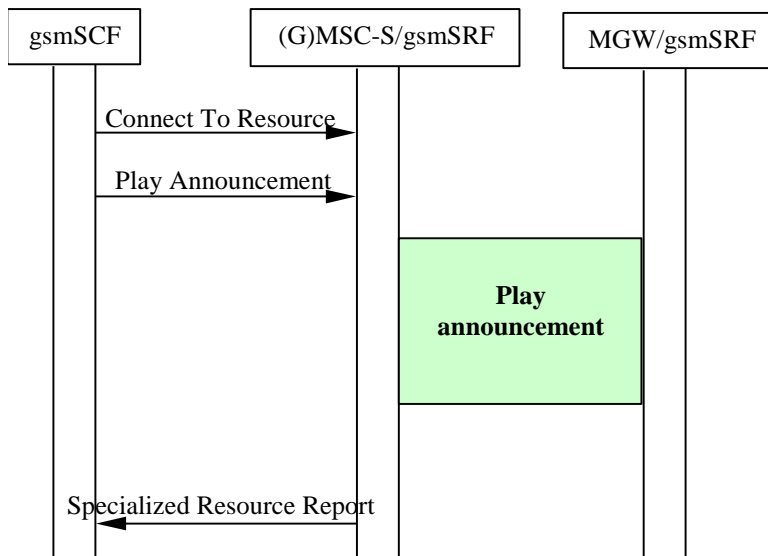


Figure 14.1: CAMEL Announcement Playing (message sequence chart)

### 14.1.2 User Interaction

The user interaction shall be performed in accordance with 3GPP TS 23.078 [10]. It shall be assumed that the MGW selected for the call has the capabilities to provide announcements. In bearer independent CS core network the DTMF digits can be propagated inband or out-of-band.

#### 14.1.2.1 Play announcement

When the gsmSCF requests the gsmSRF/SSF to play a specified announcement and to collect digits that are sent by the user the gsmSRF/SSF requests the MGW to play the announcement as described in clause 14.6.

### 14.1.2.2 Detect DTMF tones

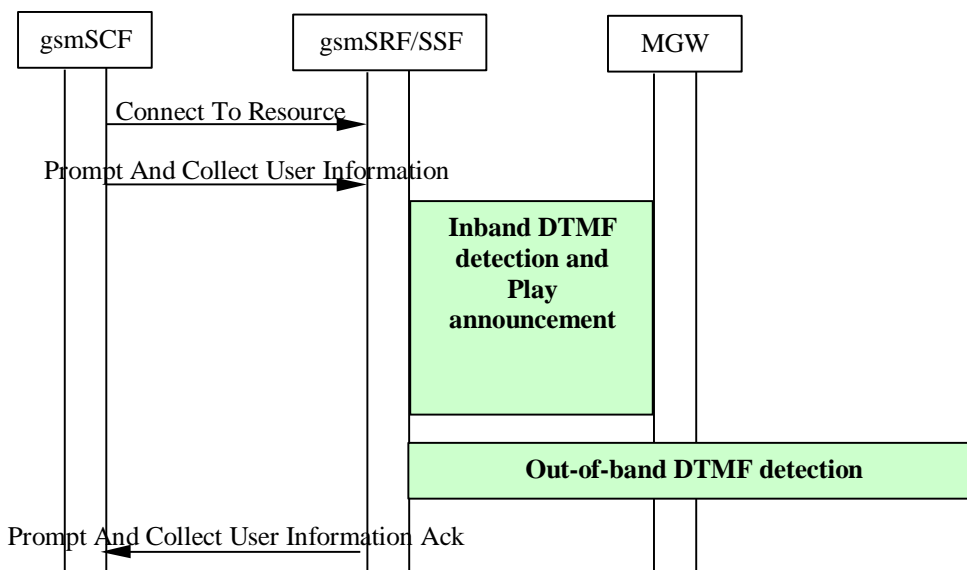
The gsmSRF/gsmSSF starts detecting DTMF tones, as describes in clause 14.4.2, before it receives the announcement or tone completed notification (see clause 14.6).

### 14.1.2.3 Report DTMF tones

The DTMF tones are reported to the gsmSRF/SSF as described in clause 14.4.2. After all requested digits are received the gsmSRF/SSF reports the digits to the gsmSCF.

### 14.1.2.4 Cancel prompt and collect user information

If the gsmSCF requests the gsmSRF to cancel the prompt and collect user information procedure, which had been started earlier, the gsmSRF orders the MGW to stop playing the announcement or sending tone, if they are still in progress, using the Stop Announcement or the Stop Tone procedure. The gsmSRF shall also order the MGW to stop detecting DTMF tones using the Stop DTMF Detection procedure.



**Figure 14.2: CAMEL User Interaction (message sequence chart)**

NOTE: Since gsmSRF don not know whether DTMF digits are provided inband or out-of-band the gsmSRF has to be able to collect DTMF tones both inband and out-of-band.

### 14.1.3 Call Party Handling (CPH)

The procedures specified in 3GPP TS 23.078 [10] for Call Party Handling (CPH) shall be followed. The following clauses describe the additional requirements for the bearer independent CS core network.

In contrast with HOLD and MPTY, the call parties created on instruction from the gsmSCF are not seen as separate calls in the Mobile Station, i.e. all call parties in a CPH configuration use the same *transaction id* towards the MS. In addition, CPH may take place in an MSC-S different from the one where the CAMEL served subscriber is registered. Furthermore, in CPH it is possible to have multiple call parties in separate *call segments* whereas the call hold supplementary service has a limit of one held call party and one active call.

The gsmSCF always triggers the elementary procedures which are described in this subclause. CPH elementary procedures can be used in more complex procedures to provide useful services, but the more complex procedures are out of scope of this specification.

NOTE: For simplicity, the figures below which show network models do not show the gsmSCF. The gsmSCF is in the HPLMN of the served (CAMEL) party. The GMSC-S is in the interrogating network (IPLMN). The MSC-S is in the VPLMN of the served party.

Use of a multi-party (conference) bridge

When the gsmSCF invokes a CPH procedure which requires the connection of three or more legs in a multi-party configuration, the MSC server selects an MGW which provides multi-party bridge capabilities. The timing of the selection of the MGW with the multi-party bridge capabilities is vendor specific. If the selected MGW is not the MGW which is used for the active call, the MSC server requests the MGW(s) to connect the bearer terminations of the participants to the selected MGW. The bearer terminations are connected together.

14.1.3.1 Call Party Handling concepts

The relationship between Call Segments and voice connections is explained in 3GPP TS 23.078 [10] subclause 4.5.1.

14.1.3.2 Initiate Call Attempt procedure

The Initiate Call Attempt (ICA) procedure is used either:

- To create a new call (out-of-the-blue), in which case the gsmSCF makes the initial contact with the MSC-S, or
- To create an additional call party in an existing call. The new call party is always created in a new call segment. The existing call may have triggered contact with the gsmSCF based on CAMEL subscription information (MO or MT in VMSC, MT in GMSC, call forwarding etc), or the gsmSCF may have initiated the contact using the ICA procedure (out-of-the-blue).

The gsmSCF may create additional call parties before it establishes the bearer to the calling party. The MSC-S/GMSC-S shall establish bearers to the additional call parties independently of the other parties, including the calling party.

The leg which is created by the Initiate Call Attempt procedure is initially in the held state.

14.1.3.2.1 Example

Figure 14.1.3/1 shows an example network model for the Initiate Call Attempt procedure with an establishment of a new call leg. The "squared" line represents the call control signalling. The "dotted" line represents the bearer control signalling and the bearer. The MSC-S seizes a new context with one bearer termination in the MGW which is used for the new call leg.

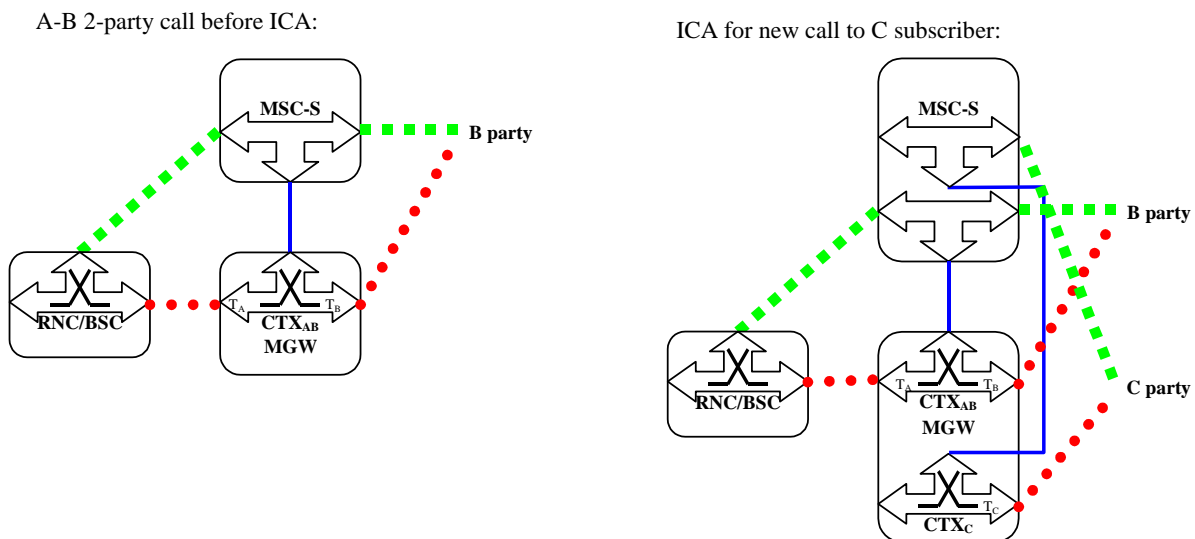


Figure 14.1.3/1 Initiate Call Attempt procedure (Network model)

Figure 14. 1.3/2 shows an example message sequence for the Initiate Call Attempt procedure.

In this example a new call leg to the C-party is established.



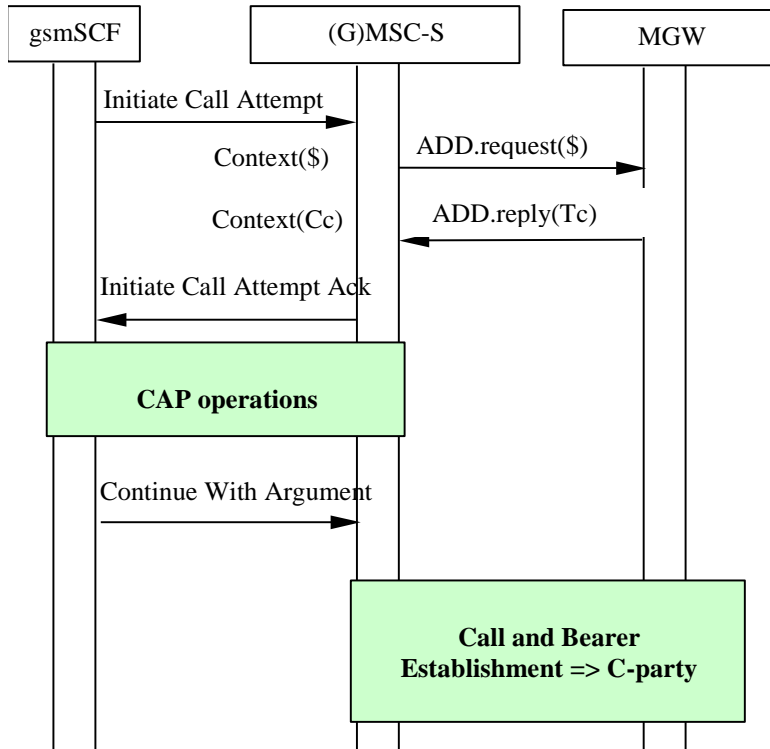


Figure 14. 1.3/2 Information flow for Initiate Call Attempt (message sequence chart)

### 14.1.3.3 Move Leg procedure

The Move Leg procedure is used to move a leg from its current call segment to the (existing) target call segment.

Using Move Leg to add a leg to a call segment which already includes 2 call legs requires the establishment of a multiparty call (if it does not already exist for the served CAMEL subscriber) as described in clause 13.7. Other call parties may be involved in independent Multiparty calls due to MPTY SS or CPH. If the call segment to which the specified leg is added is already using a multi-party bridge, the MSC server requests the MGW to establish the connection between the specified leg and the multi-party bridge.

#### Example

Figure 14. 1.3/3 shows an example network model for the Move Leg procedure. The "squared" line represents the call control signalling. The "dotted" line represents the bearer control signalling and the bearer

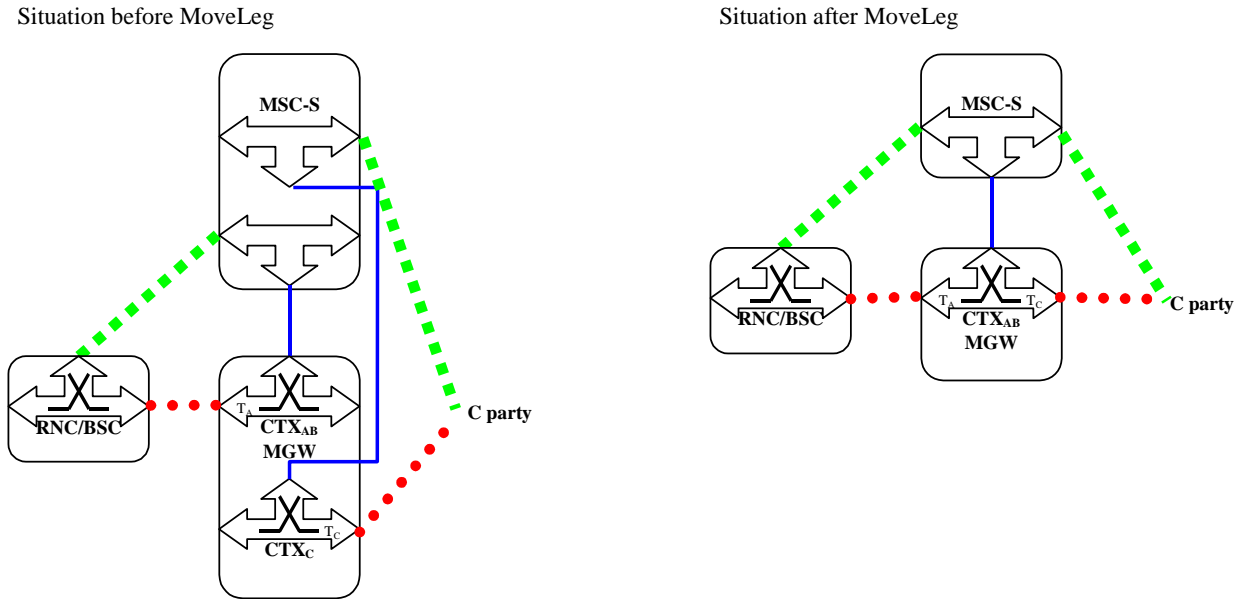


Figure 14.1.3/3 Move Leg procedure (Network model)

Figure 14.1.3/4 shows an example message sequence for the Move Leg procedure.

In this example the leg of the C-party is moved to an existing call segment. The MSC-S requests the MGW to move the bearer termination for the C-party to the same Context which contains the bearer termination for the A-party

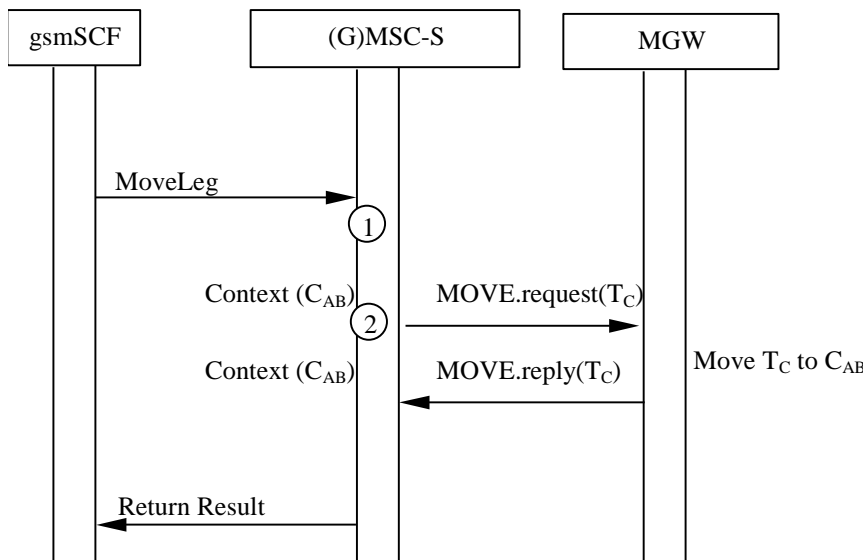


Figure 14.1.3/4 Information flow for Move Leg (message sequence chart)

### 14.1.3.4 Split Leg procedure

The Split Leg procedure is used to separate a call leg from a source call segment and place it in a (new) target call segment.

When the gsmSCF uses the Split Leg procedure to put a call leg on hold, the MSC server instructs the MGW to interrupt the connection between the specified call leg and the other party/parties in the call segment. If the call segment is using a multi-party bridge, the connection from the specified call leg to the multi-party bridge is interrupted.

Example

Figure 14. 1.3/5 shows an example network model for Split Leg procedure. The "squared" line represents the call control signalling. The "dotted" line represents the bearer control signalling and the bearer.

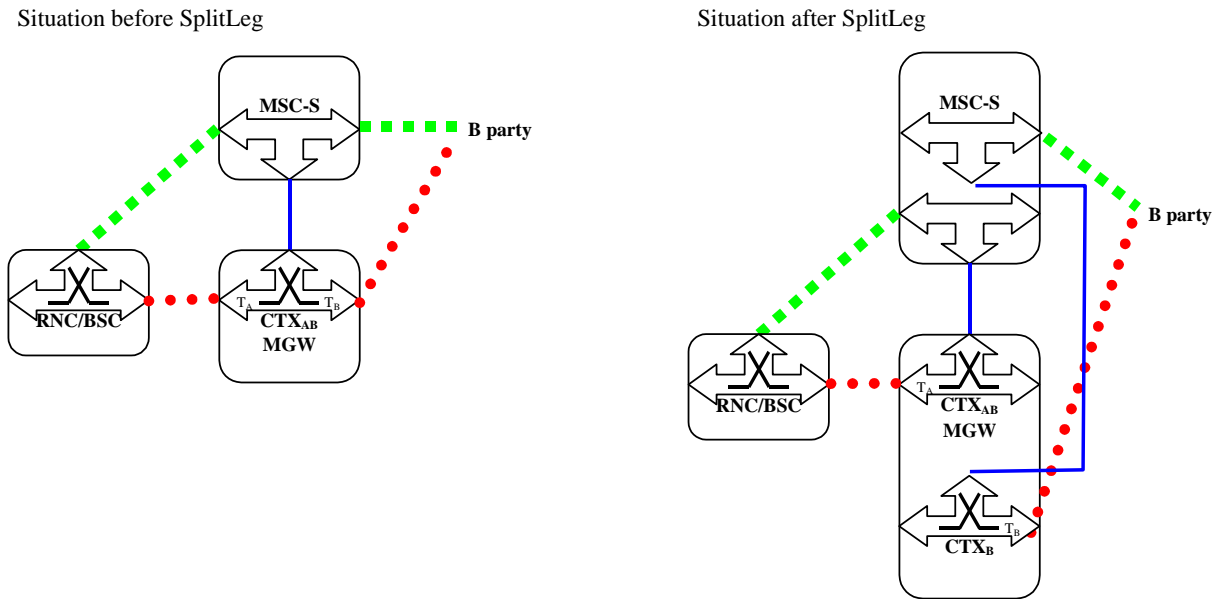


Figure 14. 1.3/5 Split Leg procedure (Network model)

Figure 14. 1.3/6 shows an example message sequence for the Split Leg procedure.

In this example the leg of the B-party is moved to a new call segment. The MSC-S requests the MGW to move the bearer termination for the B-party in the active call to a new context.

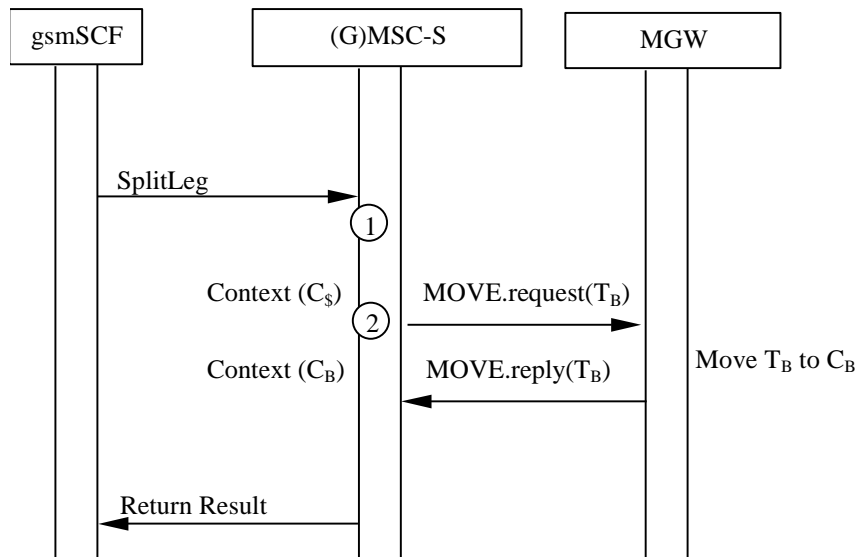


Figure 14. 1.3/6 Information flow for Split Leg (message sequence chart)

14.1.3.5 CAMEL User interaction procedure

In accordance with 3GPP TS 23.078 [10] the gsmSCF may order the MSC-S/gsmSSF to play an announcement or control user interaction as specified in subclauses 14.1.1 and 14.1.2 respectively. The tones are provided in accordance with subclause 14.6 of the present document. As part of Call Party Handling, announcements or tones can be played to an individual party or to all the parties connected in the call segment.

The gsmSCF may also instruct the MSC-S to establish a temporary connection to an external device which provides the user interaction.

#### 14.1.3.6 Failure handling in the MSC-S

If resources for Call Party Handling cannot be allocated in any of the MGWs assigned to the MSC-S, then the MSC-S shall reject the request for the Call Party Handling procedure.

### 14.2 IST

The handling of IST shall be performed in accordance with 3GPP TS 42.032 [19]. This clause describes the additional requirements for the Bearer Independent CS Core Network.

The clearing of calls due to IST is the same as for (G)MSC server initiated call clearing, refer to clause 7.3,(G)MSC server Initiated.

### 14.3 Operator Determined Barring (ODB)

NOTE: The subsequent clauses in 14.3 describe the impacts of "Barring of Outgoing Calls" and "Barring of Incoming Calls" on Bearer Independent CS CN. Other flavours of Operator Determined Barring may be supported by the Bearer Independent CS CN. However no impacts caused by these other flavours are identified.

#### 14.3.1 Barring of Outgoing Calls

If the mobile station attempts to connect to an address determined to be barred by the Operator Determined Barring service, the call shall be cleared as described in clause 7, Call Clearing.

Otherwise, the call is established as described in clause 6, Call Establishment.

#### 14.3.2 Barring of Incoming Calls

If the incoming call to the mobile station is determined to be barred by the Operator Determined Barring service, the call shall be barred. Otherwise the call shall be delivered as described in clause 6, Call Establishment.

If the GMSC connects the call to a recorded announcement due to Operator Determined Barring, the GMSC server selects the MGW before providing the in-band information. It is possible that the MGW selection is based on an MGW-Id received from the preceding node.

The incoming side bearer establishment is handled in the GMSC server as described for the mobile terminating call using either forward or backward bearer establishment.

In-band information may be provided to the calling subscriber only when both of the following conditions are satisfied:

1. Either:
  - a. The incoming IAM indicated that the Continuity message will follow, and a Continuity message has been received, or
  - b. The incoming IAM did not indicate that the Continuity message will follow;
2. Notification indicating successful completion of the incoming side bearer set-up has been received from the MGW using the Bearer Established procedure.

The GMSC server provides the MGW with the announcement identification and requests the MGW to notify the announcement completion using the Play Announcement procedure as described in clause 4.6.

After the possible announcement has been completed the GMSC server initiates the call release as described in the clause 7, Call Clearing.

## 14.4 DTMF

DTMF information can be transported either inband or out of band. In order to minimise the interworking between out of band and in band DTMF signalling, the general principle is to use the DTMF signalling method of the preceding node whenever possible. A node supporting OoB DTMF shall also be able to receive inband DTMF digits, but no DTMF digits shall be duplicated, i.e. any detected digit shall either be sent forward by inband or out-of-band, but never by both methods. Transitions between inband and out-of-band may occur due to changes to an ongoing call (Explicit Call Transfer for example) but digits shall not be sent both inband and OoB for the same link.

If out-of-band transcoder control is applied for a speech call, it shall be performed in accordance with 3GPP TS 23.153 [3]

### 14.4.1 DTMF Tone Generation

#### 14.4.1.1 Inband DTMF Tone Generation

This option uses inband signalling to transport DTMF digits in the core network.

The DTMF tone generation shall be performed in accordance with 3GPP TS 23.108 [18]. The following clauses describe the additional requirements for the bearer independent CS core network.

##### 14.4.1.1.1 Start DTMF

When the MSC server receives the Start DTMF message from the UE, it uses the Send DTMF procedure to request the MGW to modify the bearer termination to play a tone for the pressed digit. The result of the tone sending by the bearer termination will be received by the MSC server and sent to the UE (bullet 1 in figure 14.3).

##### 14.4.1.1.2 Stop DTMF

When the MSC server receives the Stop DTMF message from the UE, it uses the Stop DTMF procedure to request the MGW to modify the bearer termination to stop digit playing. When the response is received from the MGW, the MSC server will acknowledge the Stop DTMF (bullet 2 in figure 14.3).

The MGW shall check the minimum duration and minimum interval in accordance with the DTMF timing defined in TS 23.014 [33].

##### 14.4.1.1.3 Example

Figure 14.3 shows an example where out-of-band signalling of DTMF information is not supported by the call control protocol. When the UE sends Start DTMF and Stop DTMF messages, the MSC server uses resources in the MGW to generate tones by modifying the bearer termination.

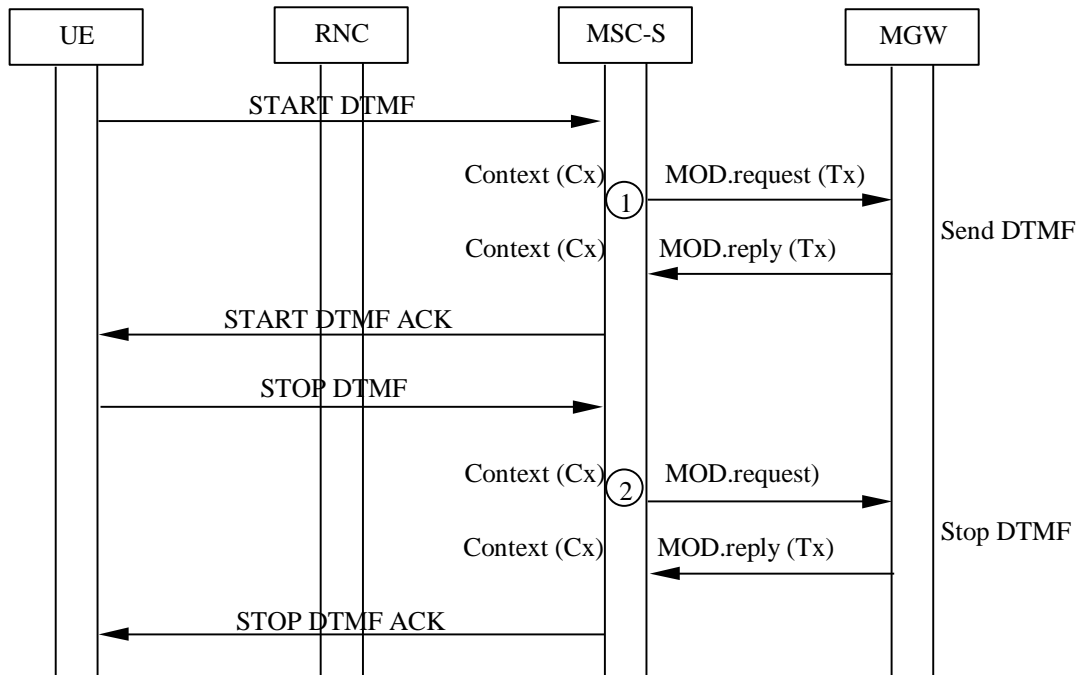


Figure 14.3: Inband DTMF generation (message sequence chart)

#### 14.4.1.2 Out-of-Band DTMF Tone Generation

This option uses out-of-band network signalling to transport DTMF digits in the core network, where the information is sent on a call control layer.

The DTMF Tone Generation shall be performed in accordance with 3GPP TS 23.108 [18]. The following clauses describe the additional requirements for the bearer independent CS core network.

##### 14.4.1.2.1 Start DTMF

When the MSC server receives a Start DTMF message from the UE, it indicates digit playing using out-of-band signalling. The corresponding result received from the preceding/succeeding node will be sent to the UE (bullet 1 in figure 14.4).

##### 14.4.1.2.2 Stop DTMF

When the MSC server receives a Stop DTMF message from the UE, it indicates stop digit playing using out-of-band signalling. The succeeding node will indicate that digit playing is stopped. The MSC server will send the result back to the UE (bullet 2 in figure 14.4).

##### 14.4.1.2.3 Example

Figure 14.4 shows the message sequence example for the out-of-band DTMF during a call. When the MSC server receives the Start DTMF and Stop DTMF messages from the UE, it shall send the information using signalling on call control layer. The MSC server will not use any dedicated resources of the MGW.

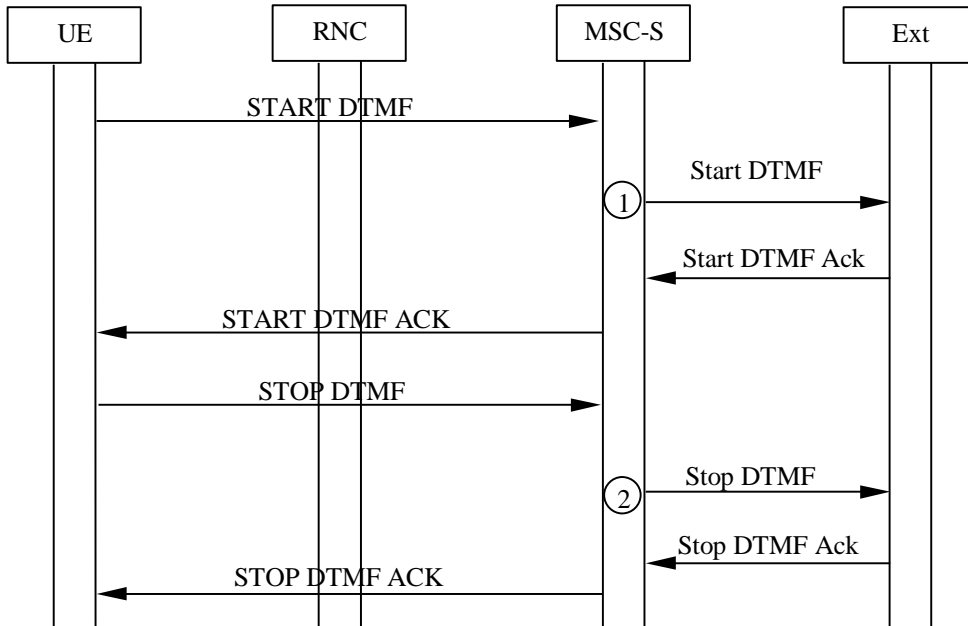


Figure 14.4: Out-of-Band DTMF generation (message sequence chart)

## 14.4.2 DTMF Detection

### 14.4.2.1 Inband DTMF Detection

The (G)MSC server/gsmSSF/gsmSRF requests the MGW to detect DTMF tones using Detect DTMF procedure (bullet 1 in figure 14.5).

At detection of the DTMF tone the MGW reports the digit to the (G)MSC server/gsmSSF/gsmSRF using the Report DTMF procedure (bullet 2 in figure 14.5). At reception of the DTMF tone report the (G)MSC server/gsmSSF/gsmSRF either expects the MGW to detect other DTMF tones (in which case no new Detect DTMF request needs to be sent) or requests the MGW to stop the detection of DTMF tone (bullet 3 in figure 14.5) using the Stop DTMF Detection procedure.

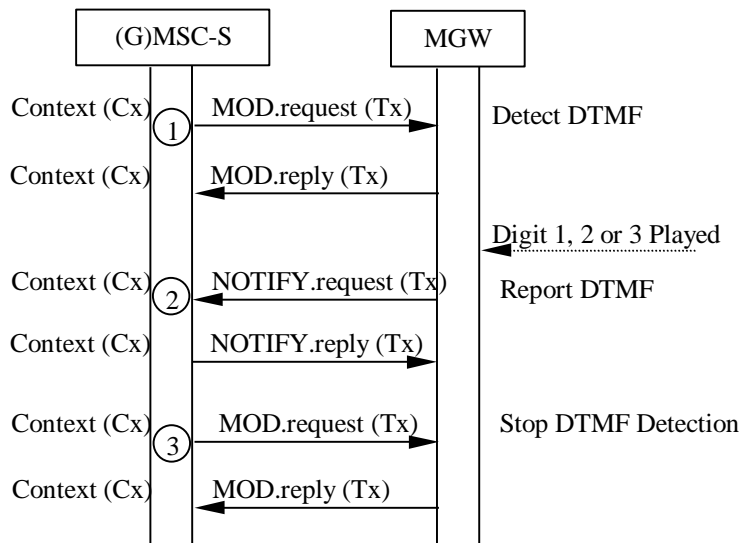
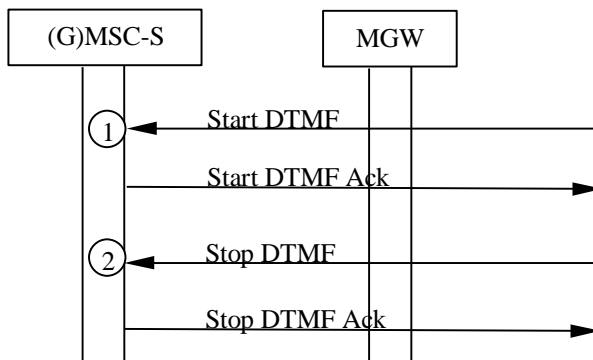


Figure 14.5: Inband DTMF detection (message sequence chart)

### 14.4.2.2 Out-of-Band DTMF Detection

The (G)MSC server/gsmSSF/gsmSRF starts collecting out-of-band DTMF tones. One DTMF tone consists of Start DTMF (bullet 1 in figure 14.6) and Stop DTMF messages (bullet 2 in figure 14.6).



**Figure 14.6: Out-of-Band DTMF detection (message sequence chart)**

## 14.5 OR

The procedures specified in 3GPP TS 23.079 [11] for the Optimal Routing network service shall be followed. The following clauses describe the additional requirements for the bearer independent CS core network.

### 14.5.1 Optimal routing for basic mobile-to-mobile calls

The optimally routed call from one mobile subscriber to another mobile subscriber is established as a normal basic call.

### 14.5.2 Optimal routing for conditional call forwarding; Early call forwarding

For early call forwarding the same procedures as described for CFU and CFNRc (rerouting by HLR) shall apply.

### 14.5.3 Optimal routing for conditional call forwarding; Late call forwarding

#### 14.5.3.1 MSC server

##### 14.5.3.1.1 Resume Call Handling and clearing of connection to GMSC server

When the MSC server determines that the call should be forwarded because the called mobile subscriber is busy (NDUB, UDUB), not reachable or has not replied to the call before the no-reply timer has expired, the MSC server sends a request to resume call handling to the GMSC server.

If the GMSC server determines that the call can be forwarded to the forwarded-to destination it sends a Release message to the MSC server. If no bearer has been established yet the MSC server handles the release only on call control level. If the bearer had been established, the MSC server handles the network side bearer release as described in the clause for the call clearing.

##### 14.5.3.1.2 IU release

When the MSC server determines that the call should be forwarded because the called mobile subscriber is busy (UDUB) or it has not replied to the call before the no-reply call timer has expired, the MSC server shall release the call and bearer connection to the served mobile subscriber as described in the clause for call clearing.



### 14.5.3.2 GMSC server

#### 14.5.3.2.1 Resume Call Handling and Clearing of Connection to visited MSC server

If the GMSC server determines that the call can be forwarded to the forwarded-to destination it sends a Release message to the MSC server and handles the outgoing side bearer release as described in the clause for call clearing, if the bearer had already been established.

#### 14.5.3.2.2 MGW selection

The GMSC server shall select an MGW for the bearer connection as described for the CFU and CFNRc (in HLR) supplementary services, if not already selected by the mobile terminating call procedures.

#### 14.5.3.2.3 Incoming side bearer establishment

The bearer establishment towards the preceding MGW is handled in the GMSC server as described for the mobile terminating call, if not already established by the mobile terminating call procedures.

#### 14.5.3.2.4 Notification to the Calling Subscriber

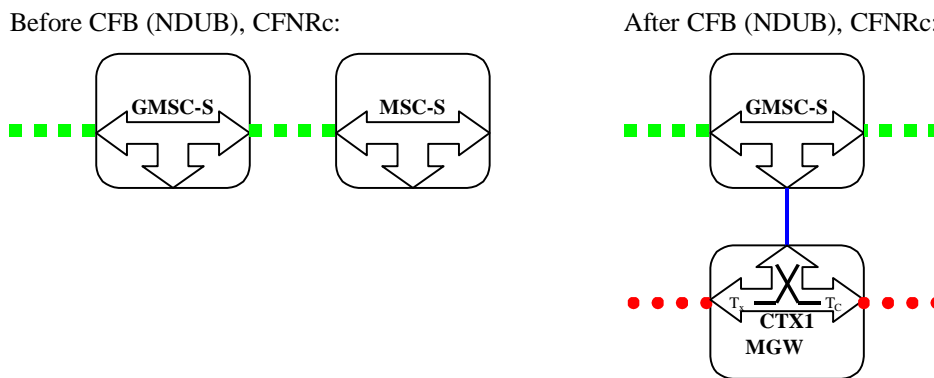
The GMSC server sends the possible notification towards the calling subscriber according to the procedures described for the CFU and CFNRc (in HLR) supplementary services.

#### 14.5.3.2.5 Establishment of call and bearer towards the forwarded-to subscriber

The GMSC server establishes the call and bearer towards the forwarded-to subscriber according to the procedures described for the CFU and CFNRc (in HLR) supplementary services.

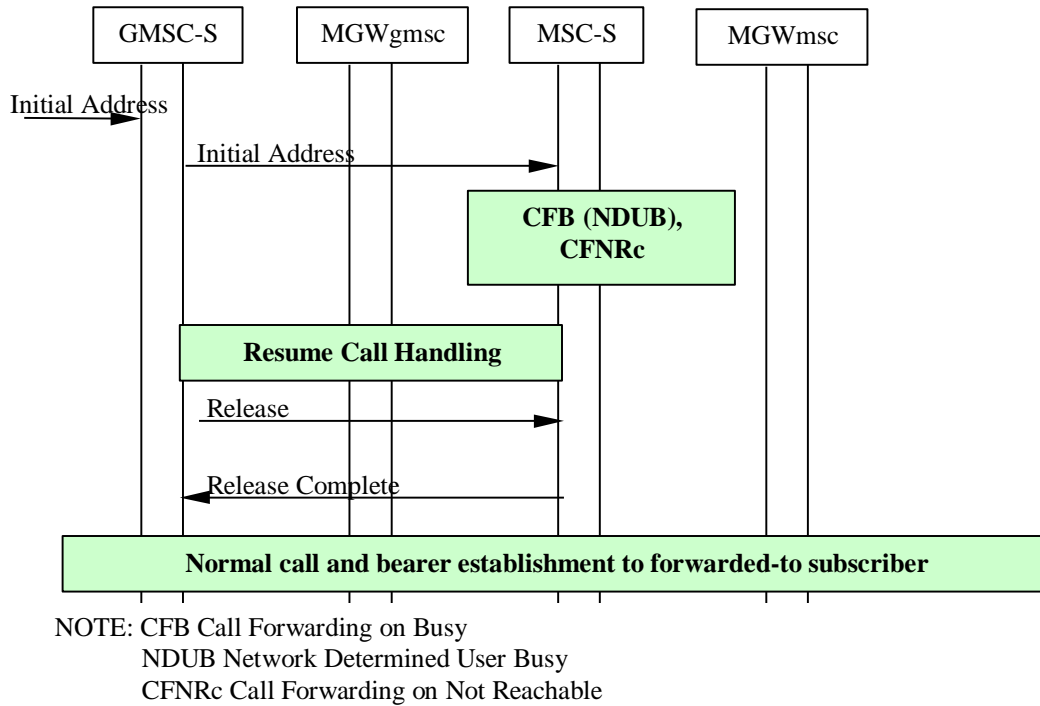
#### 14.5.3.2.6 Example

Figure 14.7 shows the network model for optimal routing when no bearer has been established before the invocation of late call forwarding. The "squared" line represents the call control signalling. The "dotted" line represents the bearer control signalling and the bearer. The GMSC server seizes one context with two bearer terminations in the MGW. The bearer termination  $T_A$  is used for the bearer towards the preceding MGW (calling subscriber) and the bearer termination  $T_C$  is used for the bearer towards the succeeding MGW (forwarded-to subscriber).



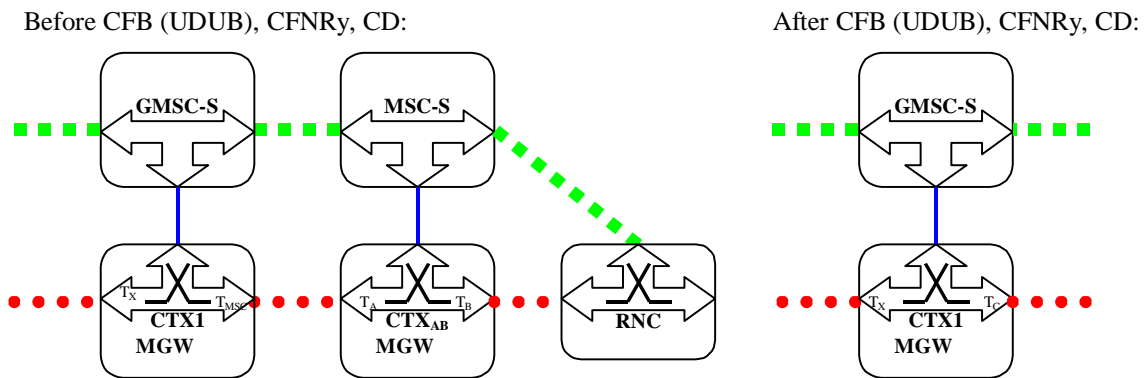
**Figure 14.7: Optimal routing; late call forwarding (CFB (NDUB), CFNRc) (Network model)**

Figure 14.8 shows the message sequence example for the optimal routing with late call forwarding without any notification to the calling party. In the example below no bearer has been established for the connection when the MSC server sends the Resume Call Handling request to the GMSC server. After the call towards the visited MSC server has been released the GMSC server establishes the call and the bearer as described for Call Forwarding Unconditional.



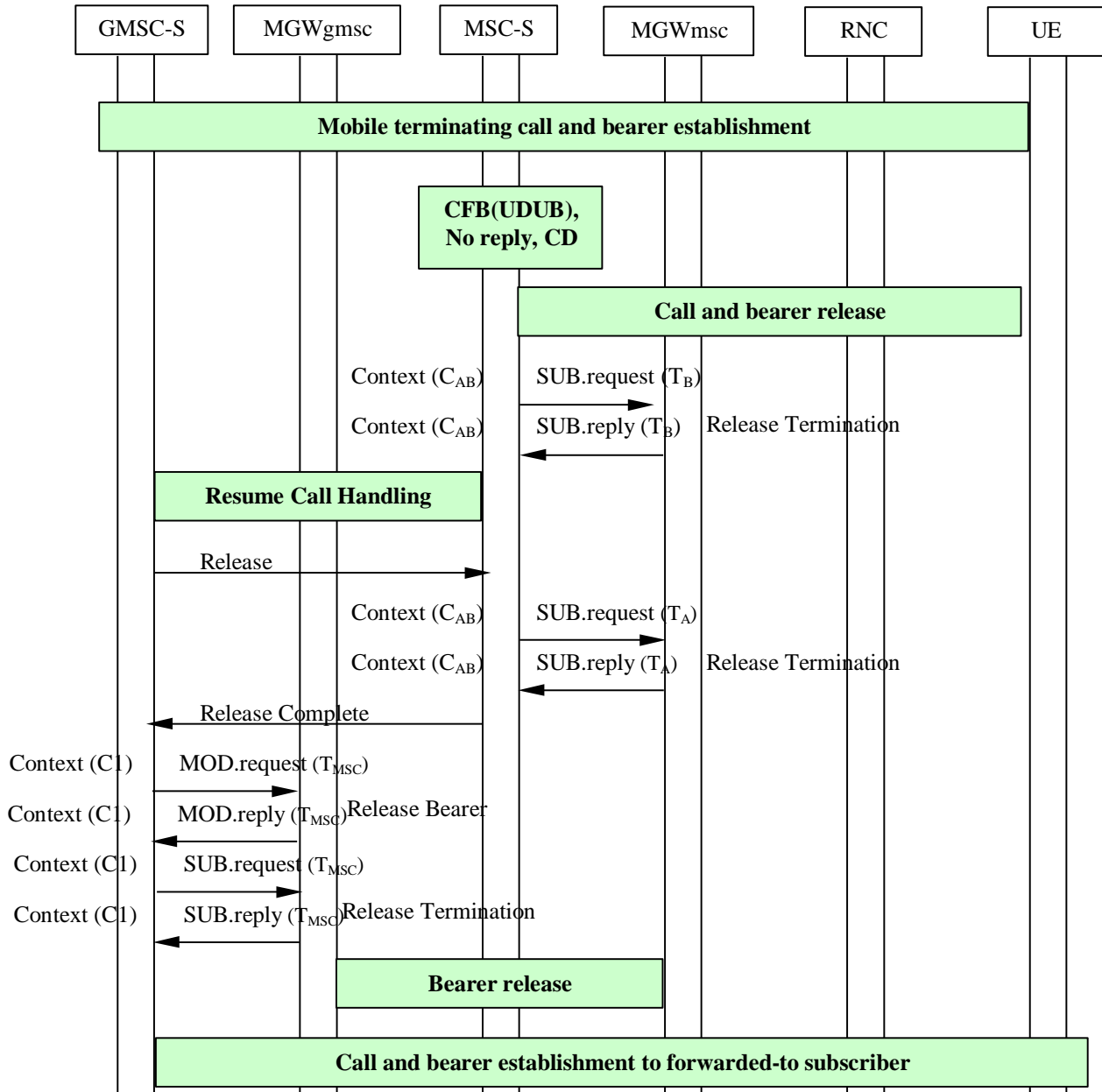
**Figure 14.8: Information flow for optimal routing; late call forwarding (CFB (NDUB), CFNRc) (message sequence chart)**

Figure 14.9 shows the network model for optimal routing when a bearer has been established before the invocation of late call forwarding. The "squared" line represents the call control signalling. The "dotted" line represents the bearer control signalling and the bearer. The GMSC server replaces the bearer termination towards the visited MSC server ( $T_{MSC}$ ) with the bearer termination for the forwarded-to subscriber ( $T_C$ ) in an existing context in the MGW. The bearer termination  $T_A$  is used for the bearer towards the preceding MGW (calling subscriber).



**Figure 14.9: Optimal routing; late call forwarding (CFB (UDUB), CFNRy, CD) (Network model)**

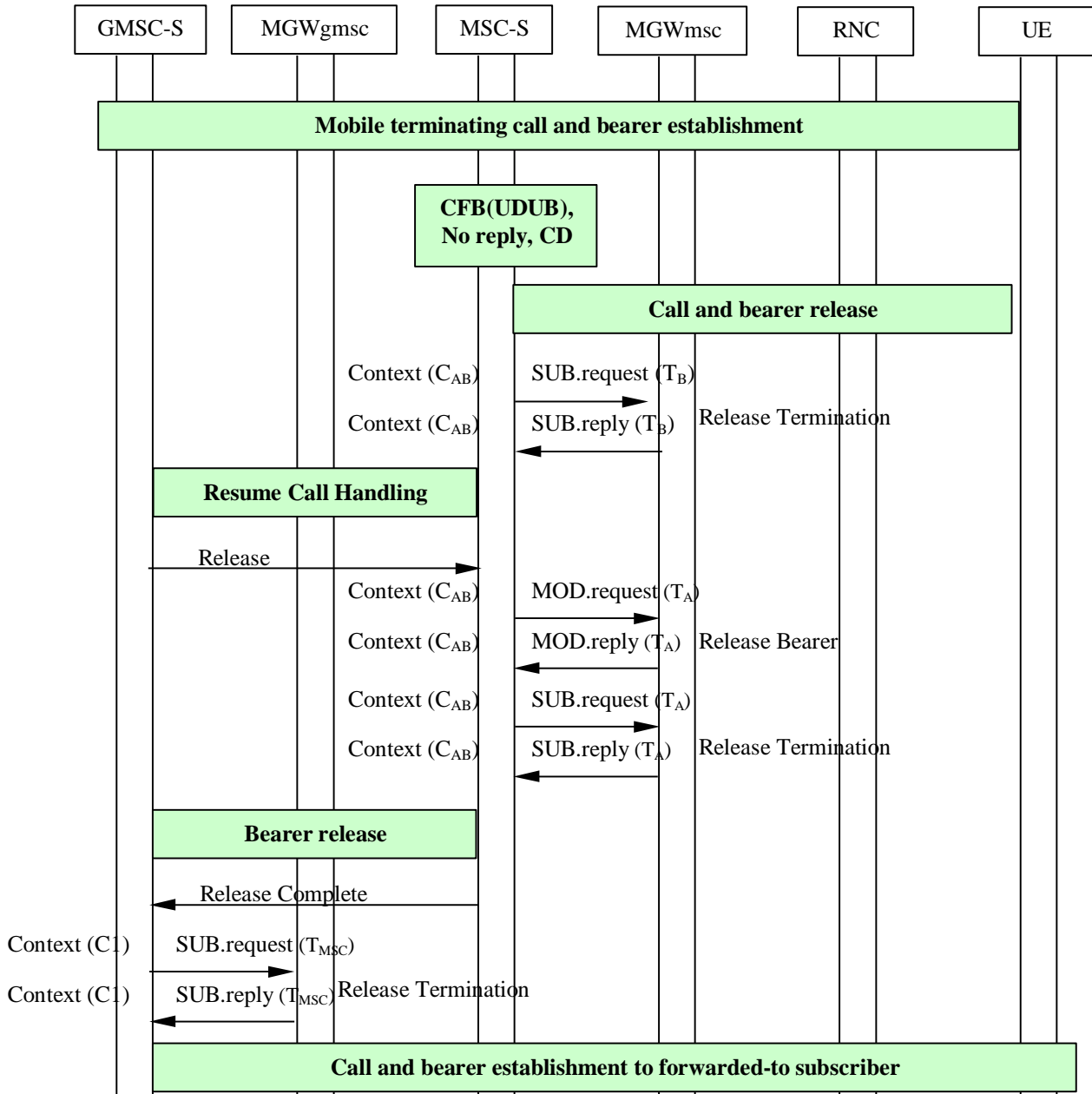
Figure 14.10 shows the message sequence example for the optimal routing for late call forwarding with a forward bearer release. In the example the MSC server requests the MGW to remove the termination towards the served mobile subscriber after the bearer towards the RNC has been released. At reception of the release message from the GMSC server the MSC server requests the MGW to be prepared for the bearer release. When the GMSC server receives the Release Complete it requests the MGW to release the bearer.



NOTE: CFB Call Forwarding on Busy  
 UDUB User Determined User Busy  
 CD Call Deflection

Figure 14.10: Information flow for optimal call routing; late call forwarding (CFB (UDUB), CFNRy, CD), forward bearer release (message sequence chart)

Figure 14.11 shows the message sequence example for the optimal routing for late call forwarding with a backward bearer release. In the example the MSC server requests the MGW to remove the termination towards the served mobile subscriber after the bearer towards the RNC has been released. At reception of the release message from the GMSC server the MSC server requests the MGW to be release the bearer. When the GMSC server receives the Release Complete it requests the MGW to remove the bearer termination.



NOTE: CFB Call Forwarding on Busy  
 UDUB User Determined User Busy  
 CD Call Deflection

**Figure 14.11: Optimal call routing; late call forwarding (CFB (UDUB), CFNRy, CD), backward bearer release (message sequence chart)**

## 14.6 Providing tones or announcements\_

It shall be assumed that the MGW selected for the call has the capabilities to provide announcements and tones.

### 14.6.1 Preconditions when providing in-band information to the calling subscriber

For a mobile terminating/forwarded call, announcements/tones may be provided to the calling subscriber only when both of the following conditions are satisfied:

1. Either:
  - a. The incoming IAM indicated that the Continuity message will follow, and a Continuity message has been received, or
  - b. The incoming IAM did not indicate that the Continuity message will follow;
2. Notification indicating successful completion of the incoming side bearer set-up has been received from the MGW using the Bearer Established procedure.

For a mobile originating call, the traffic channel assignment shall be completed before providing the in-band information to the calling subscriber.

### 14.6.2 Preconditions when providing in-band information to the called subscriber

The called party is selected by the calling party, or a supplementary service (call forwarding, call deflection, CAMEL redirection etc), or a call is initiated by the gsmSCF using the Initiate Call Attempt procedure. The called party may also be in the PSTN.

Announcements/tones may be provided to the called subscriber only when both of the following conditions are satisfied:

1. The called party has answered and is still active in the call.
2. Notification indicating successful completion of the outgoing side bearer set-up has been received from the MGW using the Bearer Established procedure.

### 14.6.3 Preconditions when providing in-band information to multiple subscribers

The gsmSCF may instruct the MSC-S/gsmSSF to provide announcements or tones for multiple subscribers. For each calling and called subscriber the precondition for calling and called subscriber (respectively) shall be fulfilled. If the preconditions are not fulfilled for all subscribers (e.g. one of the called parties is in the alerting phase), then the announcements/tones shall not be played to the subscribers who do not meet the preconditions, but the announcements/tones shall be played to the subscribers (if any) who meet the preconditions.

### 14.6.4 Request to play an announcement/tone

The (G)MSC server/gsmSSF/gsmSRF provides the MGW with the announcement/tone identification and optionally requests the MGW to notify the announcement/tone completion using the Play Announcement or Send Tone procedure (bullet 1 in figure 14.13).

### 14.6.5 Stopping an announcement/tone

The (G)MSC server/gsmSSF/gsmSRF can order the MGW to stop the current announcement/tone using the Stop Announcement or Stop Tone procedure (bullet 2 in figure 14.13).

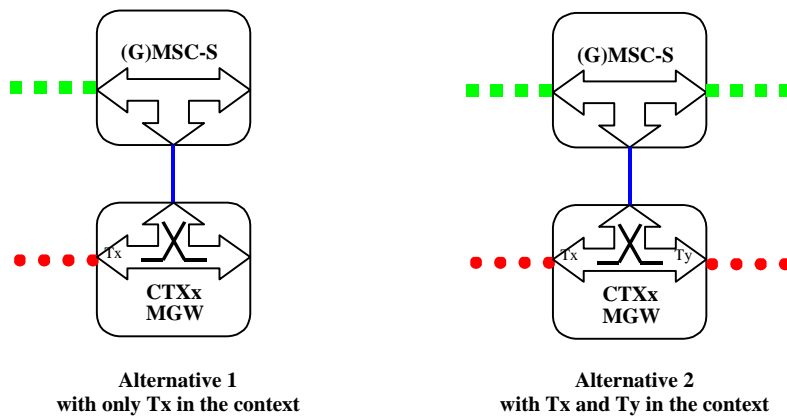
### 14.6.6 Announcement/tone completed

If notification of the announcement/tone completion was requested in the Play Announcement or Send Tone procedure, the MGW notifies the (G)MSC server/gsmSSF/gsmSRF when the announcement/tone has been completed using the Announcement Completed or Tone Completed procedure (bullet 3 in figure 14.13).

### 14.6.7 Example 1

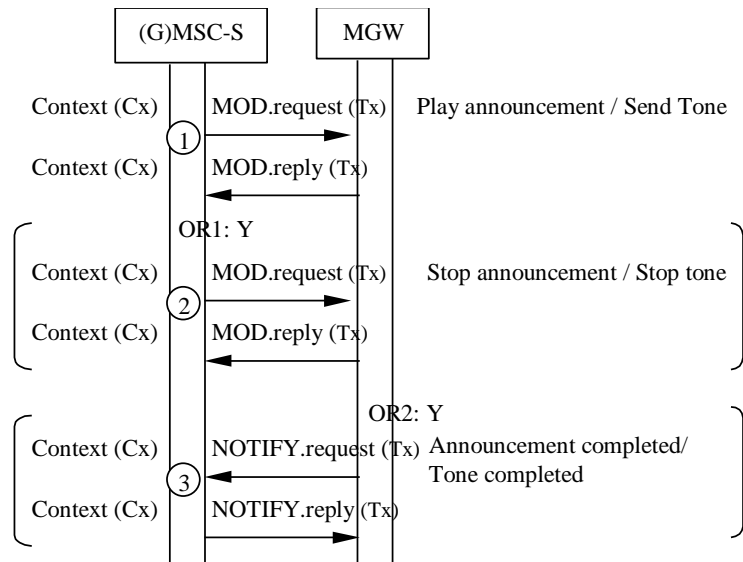
Figure 14.12 shows the network model for providing in-band information to the calling subscriber where the (G)MSC-S requests to play the announcement/tone directly on the desired termination from which the signal shall be sent. The "squared" line represents the call control signalling. The "dotted" line represents the bearer control signalling and the bearer. The bearer termination Tx is used for the bearer towards the preceding MGW (calling subscriber).

A bearer termination Ty may exist in the same context towards the succeeding MGW (called subscriber) and may be both-way connected and through-connected with Tx. In that case, the exchange of media streams between the terminations Tx and Ty is assumed to be normally interrupted during playing the announcement in the direction towards which the announcement is played.



**Figure 14.12: Providing in-band information (Network model)**

Figure 14.13 shows the message sequence example for providing the calling party with an announcement/tone. In the example the (G)MSC server requests the MGW to play an announcement/tone and to notify the announcement/tone completion. The (G)MSC server may stop the announcement while the current announcement/tone is ongoing.



NOTE: OR1: Stop the announcement/tone (Y: yes N:no)  
 OR2: Notification of completion required (Y: yes N:no)

Figure 14.13: Playing an announcement/tone (message sequence chart)

### 14.6.8 Example 2

Figure 14.6.8/1 shows the network model for providing in-band information to the calling subscriber where the (G)MSC-S requests to play the announcement/tone on another termination in the context connected via topology information to the desired termination(s). E.g. during the call setup, the MSC-S requests the MGW to send a ring back tone to the calling subscriber when receiving the indication that the called subscriber is being alerted.

The "squared" line represents the call control signalling. The "dotted" line represents the bearer control signalling and the bearer. The in-band information applied on the T0 termination is forwarded to the bearer termination(s) towards which the topology association is either 'oneway' or 'bothway', i.e. towards the Ta termination in this example.

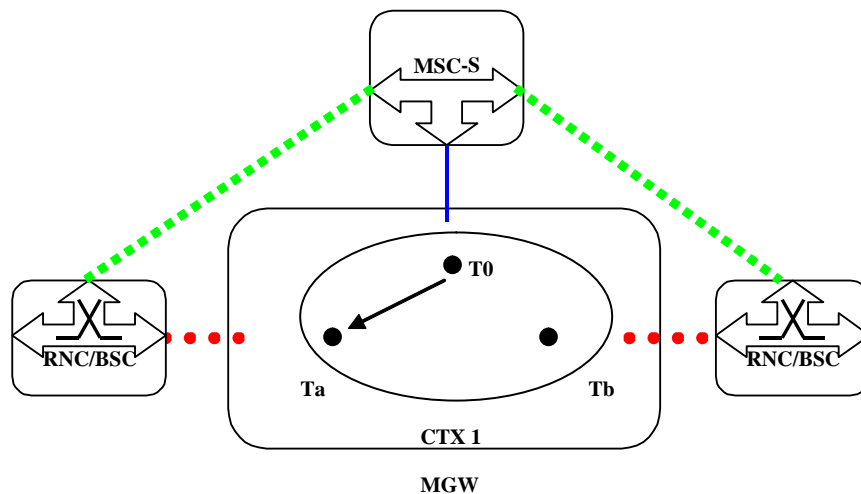
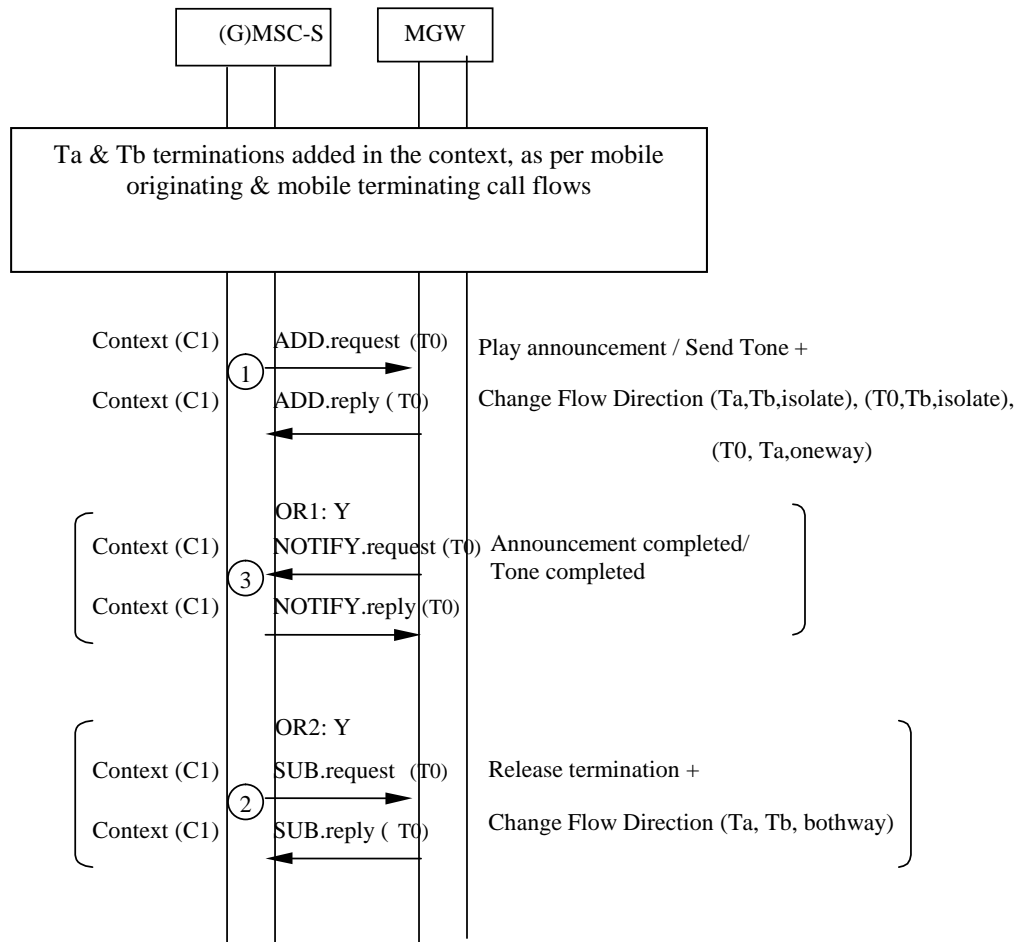


Figure 14.6.8/1: Providing in-band information (Network model)

Figure 14.6.8/2 shows the message sequence example for providing the calling party with the announcement/tone. In the example the MSC requests the MGW to play an announcement/tone by seizing a new ephemeral

announcement/tone termination with the indication that a tone or announcement shall be forwarded internally to the bearer termination(s) towards which the topology association is either 'oneway' or 'bothway'.



NOTE OR1: Notification of completion required (Y: yes , N::no)

OR2: Stop the announcement/tone (Y: yes , N::no)

Figure 14.6.8/2: Playing an announcement/tone (message sequence chart)

## 14.7 Global Text Telephony

3GPP TS 23.226 [26] describes the high level architecture and functionality of GTT. When text based conversation is needed by a subscriber, the call is established with general call control functions like any other call. Within the call control transactions the UE indicates the need for text conversation (see 3GPP TS 24.008 [4]), which then requires actions in the core network where the pooling mechanism is chosen for GTT feature. This section describes only the option where the CTM pool is provided in the Media Gateway in the Core Network.

MSC Server receives an indication by the UE about the need of text conversation, allocates terminations in MGW with CTM (Cellular Text telephony Modem) capabilities for the detection of CTM signals from radio access network. The default action of the call path in the CTM-detection/conversion function in MGW is to transfer audio transparently while monitoring for text telephone signals. When valid text telephone signals are detected, the converting action of the channel takes effect. The path converts between the detected CTM at the access termination and PSTN text telephony signalling methods on the network side. This mode of operation continues until text signalling ceases. Then transparent audio transport is re-established, again monitoring for text signals.

The CTM channel is created with Prepare bearer for Iu/ATM terminations, Prepare IP Transport for Iu/IP terminations, Reserve circuit procedure for A interface over TDM terminations or with Reserve RTP Connection Point



for A interface over IP by including Cellular Text Telephone package properties. The core network bearer shall be established with default PCM codec to carry the T.140 protocol.

The outcome of CTM negotiation towards the CTM user in the user plane is reported in the CTM report procedure.

At release the MGW may report the number of bits of Global Text Telephony data in accordance with ITU recommendation T.140 sent for the call.

## 14.8 Emergency Calls

Emergency Calls shall be handled as in clause 6.1 Basic Mobile Originating Call and clause 6.2 Basic Mobile Terminating Call. The Procedure Emergency Call Indication may be used for informing the MGW about the emergency call.

## 14.9 Subscriber and equipment trace

For the subscriber and equipment trace the MSC server may be activated for tracing (see 3GPP 32.421 [34]). Besides performing trace record generation, if Signalling based activation the MSC server shall forward the Trace Session activation to GERAN with BSSAP signaling, UTRAN with RANAP signaling (see 3GPP TS 25.413) and if the trace control and configuration parameters are defined so, the MGW. For detailed description of trace session activation mechanism see 3GPP TS 32.422 [35]. The activation to the MGW is sent using a trace package which is included either to the Add or Modify command(s) in mobile originated call or mobile terminating call. In the case of handovers where new termination is created the trace package is also included into the Add command. If the MSC does not receive the optional trace interface list IE in the trace activation request it shall request tracing on all terminations that support the total MGW trace interfaces as defined in TS 32.422. The MSC Server shall only set the trace interface list value that is associated to the interface that the termination supports and optionally the Mc interface trace value if requested from the HLR. The content of the trace records generated in the MSC server and the MGW will follow the rules of 3GPP TS 32.421[34] and 3GPP TS 32.422[35], 3GPP TS 32.423 [36]. The content of the MGW and MSC Server trace record is described in TS 32.423 [36].

## 14.10 Customized Alerting Tone

### 14.10.1 General

Customised Alerting Tone may be provided from a "CAT Server" switched into the call at appropriate trigger points. The "CAT Server" is out of the scope of the 3GPP architecture and therefore the signalling procedures towards the CAT Server (if not collocated) are not described.

The Forward CAT indicators and Backward CAT indicators information elements are specified in 3GPP TS 29.205 [22].

The following sub-clauses describe extensions to basic call handling and unless explicit exceptions are made all basic call protocol handling support is unchanged.

### 14.10.2 Audio CAT

#### 14.10.2.1 Audio CAT Activated by the Calling Party

If the calling party subscriber has activated the CAT service (CAT-A) for audio and the subscriber is in its Home PLMN and the calling party subscriber gives priority to CAT-A, the originating MSC Server supporting the audio CAT-A service shall connect that calling party UE towards the CAT Server during alerting phase. The MSC Server is responsible for switching the user plane towards the CAT Server during alerting phase and then on receipt of answer message from the called party the MSC Server shall switch the user plane towards the called party and releasing the connection to the CAT Server.

The originating MSC may indicate the CAT priority to the terminating network by setting the CAT Priority indicator of the Forward CAT indicators information element when sending an IAM to the succeeding node.

If the calling party subscriber supports CAT-A but gives priority to CAT-B and the originating MSC receives an ACM or CPG from the succeeding network with the CAT content Indicator in the Backward CAT indicators information element set to "inband media content available" then it shall not switch the user plane towards the CAT Server. If however the originating MSC does not receive an indication that CAT-B is present then it shall switch the user plane towards the CAT server as described above for the CAT-A priority case.

NOTE: Providing alerting tone at the calling party rather than from the called party network can cause voice clipping if the called party answers and speaks while the calling party network has not disconnected the inband alerting tone.

### 14.10.2.2 Audio CAT Activated by the Called Party

If the called party subscriber has activated the CAT service (CAT-B) for audio, the GMSC Server supporting the audio CAT-B service shall check the CAT Priority indicator if the Forward CAT indicators information element is received. If CAT-A priority is requested the GMSC Server shall handle the call in accordance with normal call handling not supporting CAT-B service. If no CAT-A priority is received the GMSC Server shall connect the calling party network to the CAT Server during alerting phase. The GMSC Server should indicate in ACM or CPG message if CAT-B is inserted by setting the CAT content Indicator in the Backward CAT indicators information element. The GMSC Server is responsible for switching the user plane towards the CAT Server during alerting phase and then on receipt of answer message from the called party the GMSC Server shall switch the user plane towards the called party and releasing the connection to the CAT Server.

## 14.10.3 Multimedia CAT

### 14.10.3.1 Introduction

The following subclauses specify the mobile originated and mobile terminated multimedia call procedures to generate a multimedia CAT to a UE supporting the multimedia CAT capability.

A UE supporting multimedia CAT will indicate support of this capability to the MSC server as specified in 3GPP TS 24.008 [4].

To play a multimedia CAT to such a UE, upon receiving the indication that the called party is being alerted and that a multimedia CAT is available, the MSC Server supporting multimedia CAT shall request the MGW to both-way through-connect the bearer towards the source of the multimedia CAT using the Change Through-Connection procedure, and then request the calling UE to attach to the user connection for multimedia as soon as an appropriate channel in multimedia mode is available and to set up an H.324 call by indicating "inband multimedia CAT available" within an ALERTING message or a PROGRESS message as specified in 3GPP TS 24.008 [4] subclause 5.3.6.4.

### 14.10.3.2 Multimedia CAT Activated by the Calling Party

If the calling party subscriber has activated CAT service (CAT-A) for multimedia and the subscriber is in its Home PLMN and the calling party subscriber gives priority to CAT-A, the originating MSC Server supporting multimedia CAT-A service for multimedia it shall connect that calling UE towards the CAT Server during alerting phase. The MSC Server is responsible for switching the user plane towards the CAT Server during alerting phase and then on receipt of answer message from the called party the MSC Server shall switch the user plane towards the called party and release the connection to the CAT Server.

The originating MSC may indicate CAT-A has priority to the terminating network by setting the CAT Priority indicator of the Forward CAT indicators information element to 'Priority given to Calling party (CAT-A)' when sending an IAM to the succeeding node.

NOTE: As the Forward CAT indicators information element is required to be sent by the originating MSC with the Multimedia CAT capability Indicator set to "MCAT supported" if it permits multimedia CAT-B, the inclusion of the Forward CAT indicators information element is not strictly required since if no CAT parameters are included it has the same effect as indicate CAT-A has priority however it does provide explicit indication that the calling party supports CAT-A.

If CAT-B is given priority then the Multimedia CAT capability Indicator of the Forward CAT indicators information element shall be set as described in subclause 14.10.3.3.1.

If the calling party subscriber supports CAT-A but gives priority to CAT-B and the originating MSC receives an ACM or CPG from the succeeding network with the CAT content Indicator in the Backward CAT indicators information element set to "inband media content available" then it shall not switch the user plane towards the CAT Server and shall follow the procedures defined in subclause 14.10.3.3.1. If however the originating MSC does not receive an indication that CAT-B is present then it shall switch the user plane towards the CAT server as described above for the CAT-A priority case.

### 14.10.3.3 Multimedia CAT Activated by the Called Party

#### 14.10.3.3.1 Mobile originated multimedia call

If the calling UE supports the multimedia CAT service and no CAT-A priority exists, the originating MSC supporting the multimedia CAT service shall inform the succeeding node that multimedia CAT is supported by setting the Multimedia CAT capability Indicator of the Forward CAT indicators information element to "MCAT supported" in the IAM message sent to the succeeding node.

The MSC Server supporting the multimedia CAT service shall consider that a multimedia CAT is available if it receives an ACM or CPG message including the Multimedia CAT content Indicator in the Backward CAT indicators information element set to "inband media content available".

#### 14.10.3.3.2 Mobile terminated multimedia call

If the called party subscriber supports the "CAT-B" service for multimedia and if the GMSC Server supporting the optional CAT-B service for multimedia receives the Multimedia CAT capability Indicator in the Forward CAT indicators information element set to "MCAT supported" in the IAM from the preceding node, the GMSC Server shall connect the calling party to the CAT Server during the alerting phase.

To play a multimedia CAT to the calling subscriber, upon receiving the indication that the called party is being alerted, the GMSC supporting multimedia CAT shall request the MGW to establish, and both-way through-connect, a bearer connection towards a CAT Server.

The GMSC shall inform the originating MSC that a multimedia CAT is available (if any) by setting the Multimedia CAT content Indicator of the Backward CAT indicators information element to "inband media content available" in the ACM or CPG message.

#### 14.10.3.3.3 Example

Figure 14.10.3.3.3.1 shows the message sequence chart example for providing multimedia CAT activated by the called party during a basic multimedia call establishment. In the example, the calling UE, the originating MSC and GMSC support the multimedia CAT capability.

The calling UE initiates a multimedia call establishment during which it indicates that it supports multimedia CAT capability (bullet 1). The originating MSC sends an Initial Address message to the GMSC of the called party indicating that Multimedia CAT is supported.

The GMSC server determines that the called party has a multimedia CAT subscription (bullet 6) e.g. based on OSS code retrieved from the HLR.

Upon receiving the indication that the called party is being alerted, the GMSC sets up a UDI call towards the CAT Server. Upon reception of an Address Complete message from the CAT server, it returns to the originating MSC an Address Complete or Call Progress message indicating that multimedia CAT is available (bullet 13). This leads the originating MSC to request the calling UE (supporting multimedia CAT) to attach to the user connection and to set up a H.324 call to the CAT server (bullet 14).

When the called party accepts the call, the GMSC releases the call towards the CAT server (bullet 18), waits for the Release Complete message from the CAT Server, and then through-connects the calling and called legs and returns an answer indication to the originating MSC.

Upon reception of the CONNECT message, the calling UE releases any on-going H.324 call and establishes a new H.324 call towards the called party.

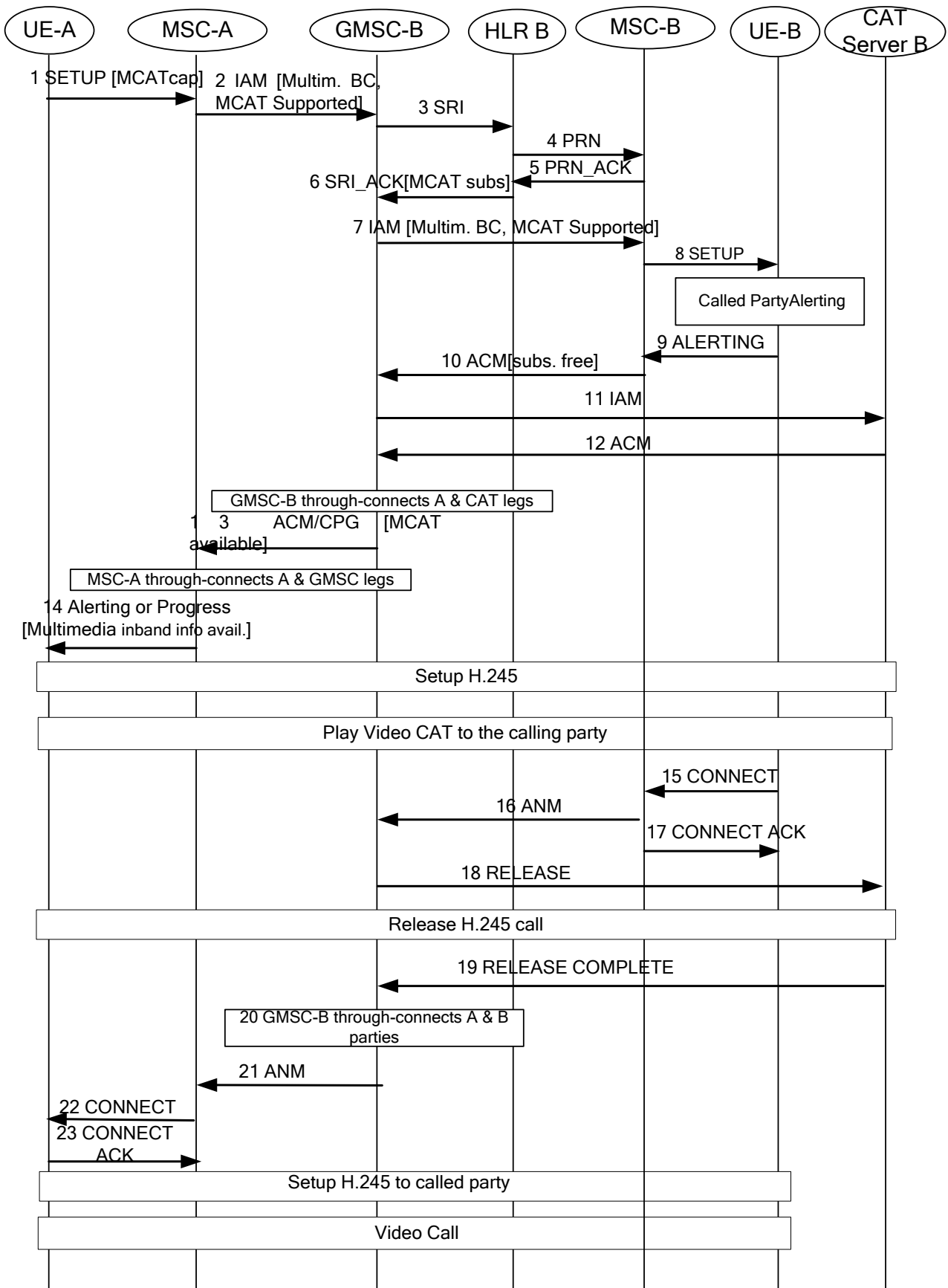


Figure 14.10.3.3.3.1: Multimedia CAT during a multimedia mobile originated call (message sequence chart)

---

## 15 Tunnelling

NOTE: All message sequence charts in this clause are examples. All valid call establishment message sequences can be derived from the example message sequences and associated message pre-conditions.

### 15.1 Forward Bearer Establishment

The following clauses describe the requirements for tunnelling transport mechanism within the bearer independent CS core network. These requirements are supplementary to those already stated in the Call Establishment clause. If out-of-band transcoder control is applied for a speech call, it shall be performed in accordance with 3GPP TS 23.153 [3].

#### 15.1.1 Outgoing Side

##### 15.1.1.1 Tunnel Selection

If the MGW selection occurs before the IAM is sent, the (G)MSC server uses the Prepare Bearer procedure to indicate a tunnel support to the MGW. Depending upon the received value, the MGW shall determine whether tunnelling shall actually be used and when to send the tunnel data (bullet 1 in figure 15.2).

If the (G)MSC server indicated that tunnelling is not supported, the bearer will be established as described in clause Call Establishment.

If the (G)MSC server indicated that fast tunnelling is supported, the MGW may select which tunnelling method to use. In this case the MGW shall select either fast tunnelling or the non-tunnelling method.

If the (G)MSC server indicated that delayed tunnelling is supported, the MGW may select which tunnelling method to use. In this case the MGW shall select either delayed tunnelling or the non-tunnelling method.

If the MGW is allowed to choose whether tunnelling is to be used, it shall select either fast, delayed, or the non-tunnelling method.

The MGW shall respond to the Prepare Bearer procedure with the used tunnel indication, when the type of tunnelling mechanism has been decided.

NOTE: For a given bearer type, other specifications may describe the mechanism to be used to transport bearer control information. An MGW is only required to comply with that specification.

##### 15.1.1.2 Initial addressing

If the MGW selection has occurred, the MGW shall respond to the Prepare Bearer procedure indicating whether tunnelling is allowed and what type of tunnelling is used – fast or delayed forward. The (G)MSC server provides a tunnel indicator to the succeeding node in the IAM to indicate that tunnelling is to be used. For fast tunnelling, the (G)MSC server waits for the MGW to use the Tunnel Information Up procedure to provide the tunnel data before the IAM is sent.

If the MGW indicates that tunnelling is not to be used, then tunnel indicator is not included in the Initial Address message and the bearer will be established as described in clause Call Establishment.

If the MGW has not been selected yet, then the (G)MSC server decides whether delayed tunnelling is supported or not. If the delayed tunnelling is supported the tunnel indicator is included to the Initial Address message to indicate that. Otherwise the tunnel indicator is not included to the Initial Address message and the bearer will be established as described in clause Call Establishment.

##### 15.1.1.3 Fast forward tunnelling

The tunnel data is transferred in the IAM and the subsequent Tunnel Information message(s).

Before the IAM is sent, the (G)MSC server waits for the MGW to use the Tunnel Information Up procedure to supply the tunnel data. The (G)MSC server sends the received tunnel data to the succeeding node in the IAM (bullet 2 in example, clause 15.2).

When the (G)MSC server receives a Tunnel Information message from the succeeding node the (G)MSC server uses the Tunnel Information Down procedure to supply the MGW with the received tunnel data (bullet 5 in example sequence 15.2).

#### 15.1.1.4 Delayed forward tunnelling

The tunnel data is transferred in the Tunnel Information messages following the Bearer Information message.

If tunnel indicator was included in the IAM indicating that delayed tunnelling is supported, the succeeding node may include the tunnel indicator to the Bearer Information message. If the tunnel indicator is received the (G)MSC server indicates the delayed tunnel support in the Establish Bearer procedure.

When the MGW sends the Tunnel Information Up procedure, the (G)MSC server sends the received tunnel data in the Tunnel Information message to the succeeding node.

When the (G)MSC server receives a Tunnel Information message from the succeeding node, the (G)MSC server uses the Tunnel Information Down procedure to send the received tunnel data to the MGW.

#### 15.1.1.5 Bearer control signalling transfer

The tunnelling of the bearer control signalling is transported transparently through the (G)MSC server during the call establishment and at any other time until Release is sent or received.

### 15.1.2 Incoming Side

#### 15.1.2.1 Initial addressing

The (G)MSC server receives the possible tunnel indicator and the tunnel data in IAM. Based on received information it provides the tunnel support indication and the tunnel data to the MGW.

#### 15.1.2.2 Tunnel Selection

If the tunnel indicator was received in the IAM, the (G)MSC server uses the received tunnel indicator to indicate the support of tunnel to the MGW. If the tunnel indicator is received in the IAM without tunnel data, the (G)MSC server checks the value of the tunnel indicator. If the tunnel indicator indicates that tunnel mechanism is to be used then delayed tunnelling is indicated to the MGW. If the tunnel indicator indicates that tunnel mechanism is supported the (G)MSC server decides whether the delayed tunnel is supported or non tunnelling mechanism is used. If both tunnel indicator and tunnel data are received in the IAM, fast tunnelling is indicated to the MGW.

If no tunnel indicator was received in the IAM, then the preceding node has indicated that non-tunnelling mechanism is to be used.

The (G)MSC server uses the Prepare Bearer procedure to supply the tunnel support indication to the MGW.

The MGW decides based on the received tunnel support indication from the (G)MSC server whether to use delayed tunnelling or not. In the response the MGW provides the used tunnel indication to the (G)MSC server.

#### 15.1.2.3 Fast forward tunnelling

The tunnel data is transferred in the IAM and the subsequent Tunnel Information message(s).

The (G)MSC server sends the tunnel data received in the IAM to the MGW using the Tunnel Information Down procedure (bullet 3 in example, clause 15.2).

When the MGW sends the Tunnel Information Up procedure, the (G)MSC server sends the received tunnel data in the Tunnel Information message to the preceding node (bullet 4 in example, clause 15.2).

### 15.1.2.4 Delayed forward tunnelling

The tunnel data is transferred in the Tunnel Information messages following the Bearer Information message.

If tunnel indicator was received in the IAM indicating that delayed tunnel is supported and delayed tunnelling was indicated by the MGW, the (G)MSC server shall include the tunnel indicator to the Bearer Information message which is sent to the preceding node.

When the (G)MSC server receives a Tunnel Information message from the preceding node, the (G)MSC server uses the Tunnel Information Down procedure to send the received tunnel data to the MGW.

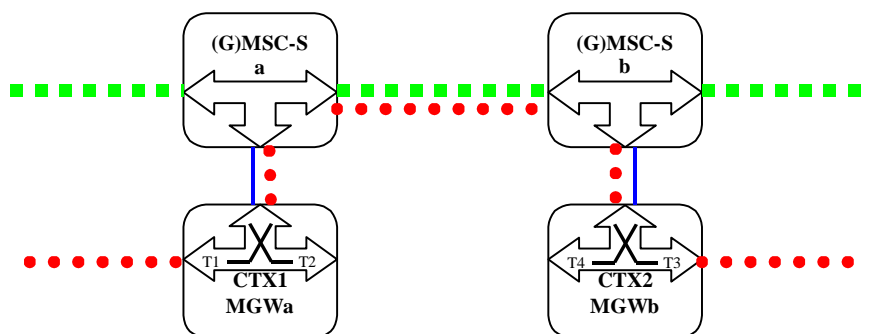
When the MGW sends the Tunnel Information Up procedure, the (G)MSC server sends the received tunnel data in the Tunnel Information message to the preceding node.

### 15.1.2.5 Bearer control signalling transfer

The tunnelling of bearer control signalling is transported transparently during the call establishment and at any other time until Release is sent or received.

### 15.1.2.6 Example

Figure 15.1 shows the network model for the forward tunnelling transport mechanism. The "squared" line represents the call control signalling. The "dotted" line represents the bearer control signalling. The (G)MSCa seizes one context with two bearer terminations in MGW<sub>a</sub>. The bearer termination T1 is used for the bearer towards the incoming side of (G)MSCa and the bearer termination T2 is used for the tunnelling towards the succeeding MGW. The (G)MSCb seizes one context with two bearer terminations in MGW<sub>b</sub>. The bearer termination T3 is used for the bearer towards the outgoing side of (G)MSCb and the bearer termination T4 is used for the tunnelling towards the preceding MGW.



**Figure 15.1: Forward Tunnelling Transport Mechanism (network model)**

Figure 15.2 shows the message sequence example for fast forward tunnelling transport mechanism. In the example (G)MSCa indicates to MGW<sub>a</sub> that fast tunnelling is requested. After MGW<sub>a</sub> has notified the (G)MSCa of the tunnel data, the IAM is sent to the (G)MSCb. The (G)MSCb indicates to MGW<sub>b</sub> that fast tunnelling is supported and sends the received tunnel data to MGW<sub>b</sub>. Once MGW<sub>b</sub> has sent the tunnel data to the (G)MSCb, the (G)MSCb sends a Tunnel Information message with the tunnel data to the (G)MSCa. The (G)MSCa sends the received tunnel data to MGW<sub>a</sub>. The handling of Continuity message, through-connection and answer is as normal for non-tunnelled forward bearer establishment.

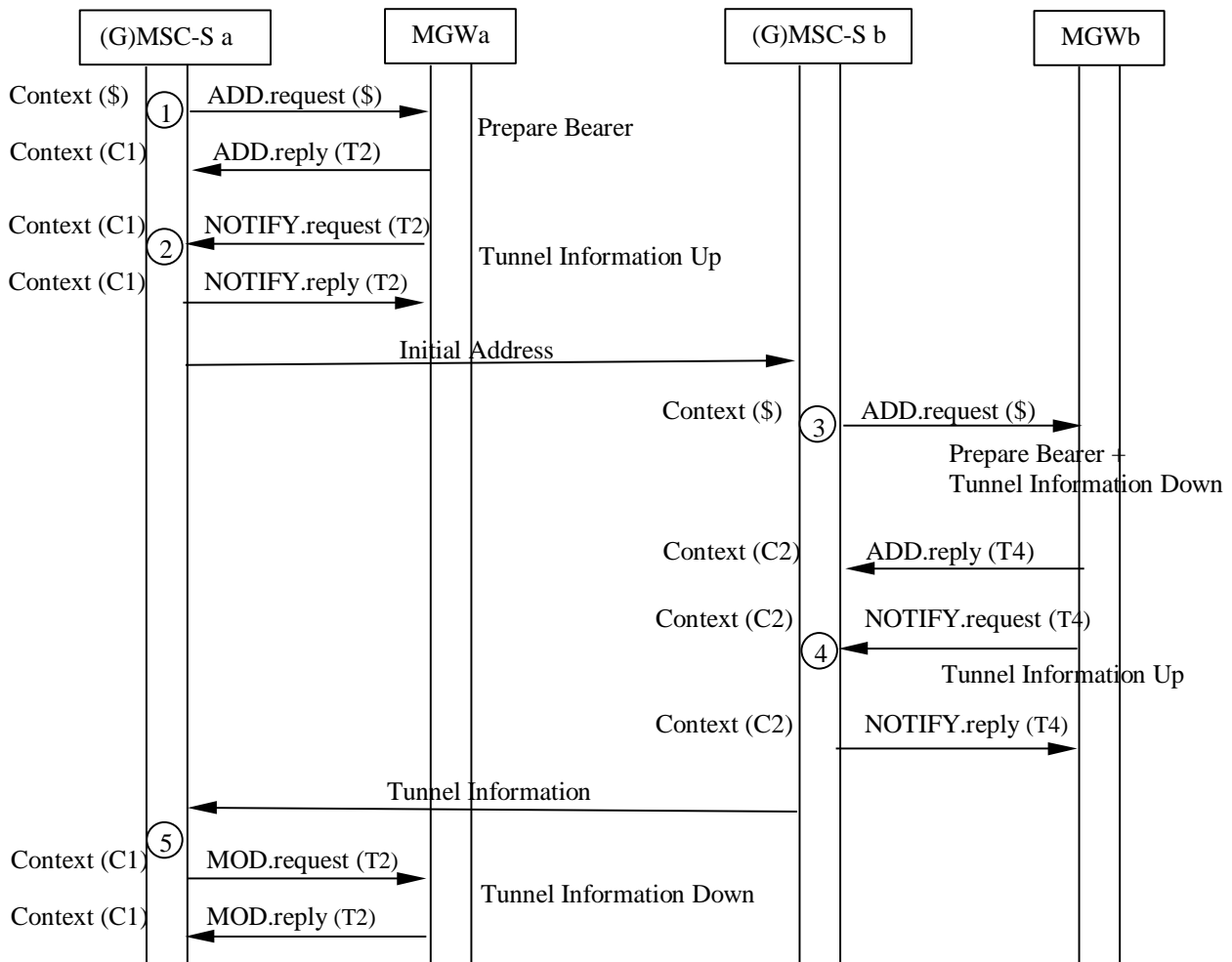


Figure 15.2: Fast Forward Tunnelling Transport Mechanism (message sequence chart)

## 15.2 Backward Bearer Establishment

The following clauses describe the additional requirements for tunnelling transport mechanism within the bearer independent CS core network. If out-of-band transcoder control is applied for a speech call, it shall be performed in accordance with 3GPP TS 23.153[3].

### 15.2.1 Outgoing Side

#### 15.2.1.1 Tunnel Selection

The (G)MSC server uses the Prepare Bearer procedure to indicate a tunnel support to the MGW. Depending upon the received value, the MGW shall determine whether tunnelling shall actually be used and when to send the tunnel data (bullet 1 in example, clause 15.4).

If the (G)MSC server indicated that tunnelling will be not supported, the bearer is established as described in clause Call Establishment.

If the (G)MSC server indicated that fast tunnelling is supported, the MGW may select which tunnelling method it can use. In this case the (G)MSC may select either fast tunnelling or the non-tunnelling method.

If the (G)MSC server indicated that delayed tunnelling is supported, the MGW may select which tunnelling method it can use. In this case the (G)MSC server may select either delayed tunnelling the non-tunnelling method.

If the MGW is allowed to choose whether tunnelling is to be used, it shall select either fast, delayed or the non-tunnelling method.



After MGW has decided which tunnelling mechanism to use, it responds to the Prepare Bearer procedure with the used tunnel indication.

#### 15.2.1.2 Initial addressing

The MGW shall respond to the Prepare Bearer procedure to indicate whether tunnelling is allowed and what type of tunnelling is used – fast or delayed forward. The (G)MSC server provides a tunnel indicator to the succeeding node in the IAM. For fast tunnelling, the (G)MSC server waits for the MGW to use the Tunnel Information Up procedure to provide the tunnel data before the IAM is sent.

If the MGW indicates that tunnelling is not to be used, the bearer will be established as described in clause Call Establishment.

#### 15.2.1.3 Fast forward tunnelling

The tunnel data is transferred in the IAM and the subsequent Tunnel Information message(s).

Before the IAM is sent, the (G)MSC server waits for the MGW to use the Tunnel Information Up procedure to supply the tunnel data. The (G)MSC server sends the received tunnel data to the succeeding node in the IAM.

When the (G)MSC server receives a Tunnel Information message from the succeeding node the (G)MSC server uses the Tunnel Information Down procedure to supply the MGW with the received tunnel data.

#### 15.2.1.4 Delayed backward tunnelling

The tunnel data is transferred in the Tunnel Information messages following the IAM.

When the (G)MSC server receives a Tunnel Information message from the succeeding node the (G)MSC server uses the Tunnel Information Down procedure to supply the MGW with the received tunnel data (bullet 4 in example, clause 15.4).

When the MGW sends the Tunnel Information Up procedure, the (G)MSC server sends the received tunnel data in the Tunnel Information message to the succeeding node (bullet 5 in example, clause 15.4).

#### 15.2.1.5 Bearer control signalling transfer

The tunnelling of bearer control signalling is transported transparently through the (G)MSC server during the call establishment and at any other time until Release is sent or received.

### 15.2.2 Incoming Side

#### 15.2.2.1 Initial addressing

The (G)MSC server receives the possible tunnel indicator and the tunnel data in the IAM. Based on received information it provides the tunnel support indication and the tunnel data to the MGW.

#### 15.2.2.2 Tunnel Selection

If the tunnel indicator was received in the IAM, the (G)MSC server uses the received tunnel indicator to indicate the support of tunnel to the MGW. If the tunnel indicator is received in the IAM without tunnel data, delayed tunnelling is indicated to the MGW. If tunnel indicator and tunnel data are received in the IAM, fast tunnelling is indicated to the MGW.

The (G)MSC server uses the Establish Bearer procedure to supply the tunnel support indication to the MGW (bullet 2 in example, clause 15.4).

#### 15.2.2.3 Fast forward tunnelling

The tunnel data is transferred in the IAM and the subsequent Tunnel Information message(s).

The (G)MSC server sends the tunnel data received in the IAM to the MGW using the Tunnel Information Down procedure.

When the MGW sends the Tunnel Information Up procedure, the (G)MSC server sends the received tunnel data in the Tunnel Information message to the preceding node.

#### 15.2.2.4 Delayed backward tunnelling

When the MGW sends the Tunnel Information Up procedure, the (G)MSC server sends the received tunnel data in the Tunnel Information message to the preceding node (bullet 3 in example, clause 15.4).

When the MGW receives an Nb User Plane Initialisation message (bullet 5a in example sequence 15.4), before the subsequent Tunnel Information Down procedure (bullet 6 in example sequence 15.4), the MGW may acknowledge this Nb User Plane Initialisation message without waiting for the Tunnel Information Down procedure, and send the acknowledge message towards the IP address and port that were supplied as source within the IP packet transporting the Nb User Plane Initialisation message (bullet 5b in example sequence 15.4). The MGW shall use the same RTP Payload-Type number for the acknowledge message, which was used in the RTP header of the packet transporting the Nb User Plane Initialisation message.

Alternatively, when the MGW receives an Nb User Plane Initialisation message (bullet 5a in example sequence 15.4), before the subsequent Tunnel Information Down procedure (bullet 6 in example sequence 15.4), the MGW may wait for the Tunnel Information Down procedure, before sending the Nb User Plane Initialisation acknowledge message (bullet 6a in example sequence 15.4). While waiting for the Tunnel Information Down procedure, the MGW may receive repetition(s) of the Nb User Plane Initialisation message and shall not treat this as error case.

When the (G)MSC server receives a Tunnel Information message from the preceding node, the (G)MSC server uses the Tunnel Information Down procedure to send the received tunnel data to the MGW (bullet 6 in example, clause 15.4).

After receiving the Tunnel Information Down procedure (bullet 6 in example sequence 15.4) and acknowledging the NbFP Init message (bullet 5b or 6a in example sequence 15.4), the MGW shall notify the MSC server about the bearer establishment (bullet 7 in example sequence 15.4).

#### 15.2.2.5 Bearer control signalling transfer

The tunnelling of bearer control signalling is transported transparently through the (G)MSC server during the call establishment and at any other time until Release is sent or received.

#### 15.2.2.6 Example

Figure 15.3 shows the network model for the backward delayed tunnelling transport mechanism. The "squared" line represents the call control signalling. The "dotted" line represents the bearer control signalling. The (G)MSCa seizes one context with two bearer terminations in MGW<sub>a</sub>. The bearer termination T1 is used for the bearer towards the incoming side of (G)MSCa and the bearer termination T2 is used for the tunnelling towards the succeeding MGW. The (G)MSCb seizes one context with two bearer terminations in MGW<sub>b</sub>. The bearer termination T3 is used for the bearer towards the outgoing side of (G)MSCb and the bearer termination T4 is used for the tunnelling towards the preceding MGW.

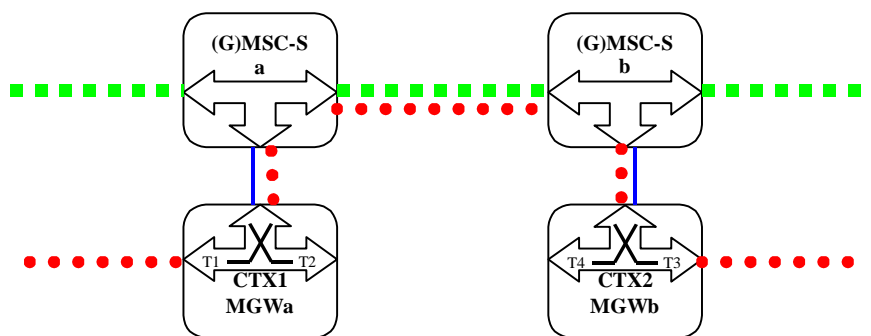


Figure 15.3: Delayed Backward Tunnelling Transport Mechanism (network model)

Figure 15.4 shows the message sequence example for backward tunnelling transport mechanism. In the example the (G)MSCa indicates to MGWa that delayed tunnelling is requested. After MGWa has responded the (G)MSCa of tunnelling, the IAM is sent to (G)MSCb. The (G)MSCb indicates to MGWb that delayed tunnelling is supported. Once MGWb has sent the tunnel data to the (G)MSCb, the (G)MSCb sends the received tunnel data in the Tunnel Information message to the (G)MSCa. The (G)MSCa sends the received tunnel data to MGWa. Once MGWa has sent the tunnel data to the (G)MSCa, the (G)MSCa sends the received tunnel data in the Tunnel Information message to the (G)MSCb. The (G)MSCb sends the received tunnel data to MGWb. The handling of Continuity message, through-connection and answer is as normal for non-tunnelled backward bearer establishment.

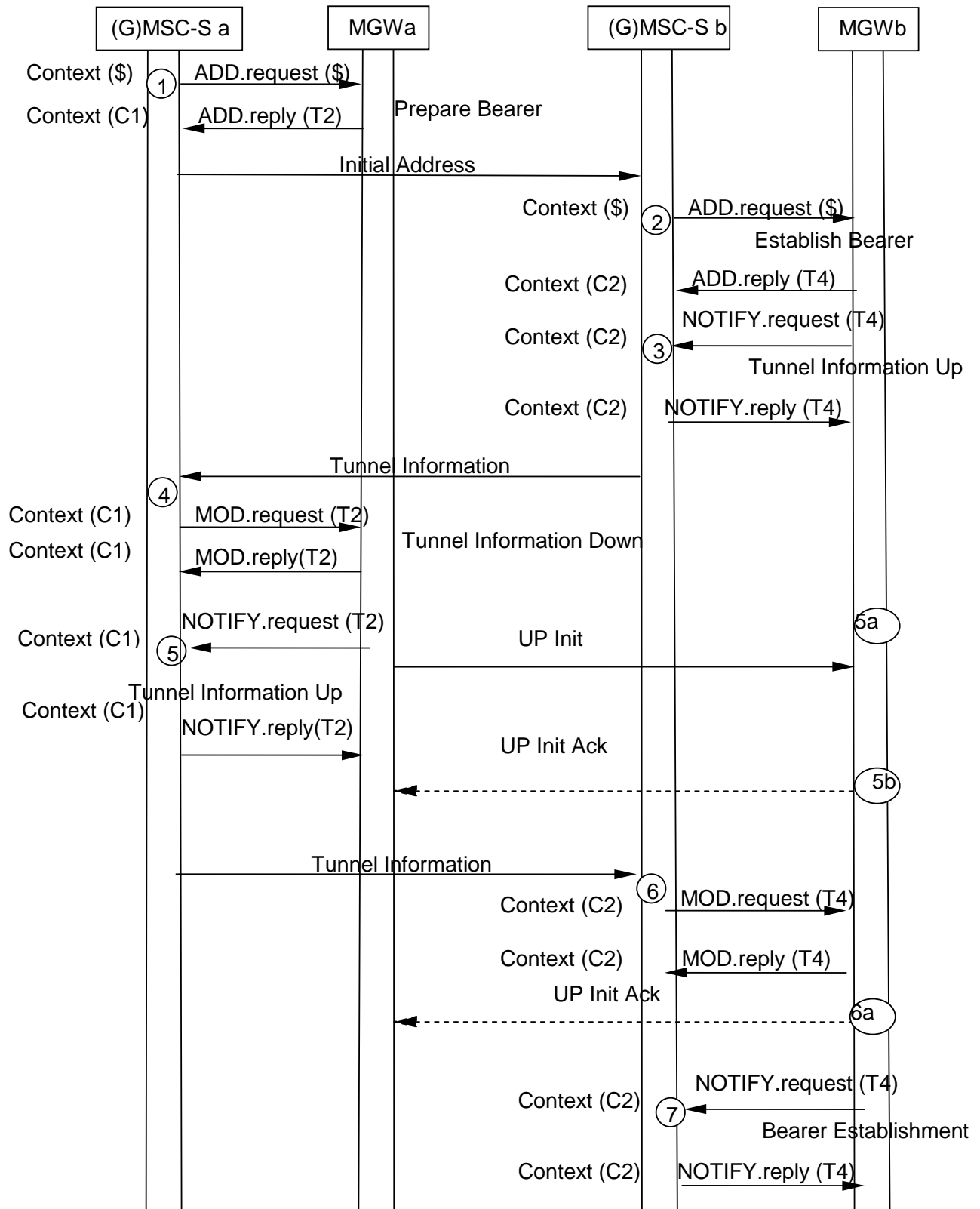


Figure 15.4: Delayed Backward Tunnelling Transport Mechanism (message sequence chart)

## 16 Messages/Procedures and their contents

This clause contains the detailed description of the information flows used in bearer independent CS core network.

Each Information Element, IE, is marked as (M) Mandatory, (C) Conditional or (O) Optional. A mandatory information element shall always be present. A conditional information shall be present if certain conditions are fulfilled; if those conditions are not fulfilled it shall be absent. An optional information element may be present or absent, at the discretion of the application at the sending entity. This categorisation is a functional classification, i.e., stage 2 information and not a stage 3 classification to be used for the protocol.

The stage 2 and stage 3 message and information element names are not necessarily identical.

## 16.1 Messages between (G)MSC servers

Table 16.1 indicates messages between (G)MSC servers in Nc interface. Only the new messages and information elements required by the bearer independent CS core network are shown.

Table 16.1: Messages between (G)MSC servers

Message	Message direction	Information element name	Information element required	Information element description
Initial Address	Forward	Bearer Establishment Direction	M	This information element indicates that the direction of bearer establishment.
		Bearer Address	C	This information element indicates the bearer address of the MGW used by the preceding node. This information element is included when an AAL2 bearer is established using backward bearer establishment control protocol. Otherwise the information element is optional.
		Binding Reference	C	This information element indicates the bearer identifier in the MGW used by the preceding node. This information element is included when an AAL2 bearer is established using backward bearer establishment control protocol. Otherwise the information element is optional.
		MGW-id	O	This information element indicates the MGW selected by the preceding node.
		Bearer Characteristics	M	This information element indicates the characteristics of the bearer.
		Tunnel Indicator	O	This information element indicates either that tunnelling is to be used or tunnelling is supported.
		Tunnel data	O	This information element contains the tunnel data that is provided between MGWs.
Bearer Information	Backward	Bearer Address	C	This information element indicates the bearer address of the MGW used by the succeeding node. This information element is included when an AAL2 bearer is established using forward bearer establishment control protocol. Otherwise the information element is optional.
		Binding Reference	C	This information element indicates the bearer identifier in the MGW used by the succeeding node. This information element is included when an AAL2 bearer is established using forward bearer establishment control protocol. Otherwise the information element is optional.
		MGW-id	O	This information element indicates the MGW selected by the succeeding node.
		Tunnel Indicator	O	This information element indicates that tunnelling is used.
Tunnel Information	Both	Tunnel Indicator	M	This information element indicates that the message contains tunnelling information.
		Tunnel data	M	This information element contains the tunnel data that is provided between MGWs.
Start DTMF	Both	Start DTMF indicator	M	This information element indicates that the message is used for Start DTMF.
		Digit	M	This information element indicates the digit for DTMF tone generation.
Start DTMF Ack	Both	Start DTMF Ack indicator	M	This information element indicates that the message is used for Start DTMF Ack.
Stop DTMF	Both	Stop DTMF indicator	M	This information element indicates that the message is used for Stop DTMF.
Stop DTMF Ack	Both	Stop DTMF Ack indicator	M	This information element indicates that the message is used for Stop DTMF Ack.

## 16.2 Procedures between (G)MSC server and MGW

The clauses below indicate the procedures used between (G)MSC server and MGW in Mc interface. The procedures are logical, i.e. message identifiers are not part of the protocol. Several logical procedures can be combined into one H.248 command in order to perform required transactions. If several logical procedures are combined, only one context/context request and only one bearer termination/bearer termination request is sent in the H.248 command. Exemption is the Change Flow Direction procedure, where the two bearer terminations are related to a change of the context and not to a command of the bearer termination. All the procedures below describe a successful operation. If the procedure is rejected, a Command Reject is sent back to the entity that sent the command request.

### 16.2.1 Change Flow Direction

This procedure is used to change the flow direction between bearer terminations within the context.

**Table 16.2: Procedures between (G)MSC server and MGW: Change Flow Direction**

Procedure	Initiated	Information element name	Information element required	Information element description
Change Flow Direction	(G)MSC-S	Context/Context Request	M	This information element indicates the existing context or a new context where the flow direction is changed.
		Bearer Termination 1/ Bearer Termination 1 Request	M	This information element indicates the existing bearer termination or a new bearer termination from where the new flow direction is applied.
		Bearer Termination 2/ Bearer Termination 2 Request	M	This information element indicates the existing bearer termination or a new bearer termination where to the new flow direction is applied.
		Flow Direction	M	This information element indicates the flow direction from the bearer termination 1 to bearer termination 2 within the context.
Change Flow Direction Ack	MGW	Context	M	This information element indicates the context where the command was executed.

NOTE 1: This procedure may be combined with Prepare Bearer, Prepare\_IP\_Transport, Establish Bearer, Reserve Circuit, Reserve RTP Connection Point, Configure RTP Connection Point or Reserve and Configure RTP Connection Point, Join Bearer Termination or Isolate Bearer Termination procedure. This list of procedures is not exhaustive.

NOTE 2: Only one of the bearer terminations can be a new bearer termination within this procedure.

## 16.2.2 Join Bearer Termination

This procedure is used to join a bearer termination with other bearer terminations within the context.

**Table 16.3: Procedures between (G)MSC server and MGW: Join Bearer Termination**

Procedure	Initiated	Information element name	Information element required	Information element description
Join Bearer Termination	(G)MSC-S	Context	M	This information element indicates the context where the bearer termination is joined.
		Bearer Termination/Bearer Termination Request	M	This information element indicates the existing bearer termination or requests a new bearer termination to be joined with the other bearer terminations within the context.
Join Bearer Termination Ack	MGW	Context	M	This information element indicates the context where the command was executed.
		Bearer Termination	M	This information element indicates the bearer termination where the command was executed.

## 16.2.3 Isolate Bearer Termination

This procedure is used to isolate one bearer termination from the other bearer terminations within the context.

**Table 16.4: Procedures between (G)MSC server and MGW: Isolate Bearer Termination**

Procedure	Initiated	Information element name	Information element required	Information element description
Isolate Bearer Termination	(G)MSC-S	Context/Context Request	M	This information element indicates the existing context or a new context where to the bearer termination is isolated.
		Bearer Termination/Bearer Termination Request	M	This information element indicates the existing bearer termination or requests a new bearer termination to be isolated from the other bearer terminations within the context.
Isolate Bearer Termination Ack	MGW	Context	M	This information element indicates the context where the command was executed.
		Bearer Termination	M	This information element indicates the bearer termination where the command was executed.



## 16.2.4 Establish Bearer

This procedure is used to request a bearer establishment.

**Table 16.5: Procedures between (G)MSC server and MGW: Establish Bearer**

Procedure	Initiated	Information element name	Information element required	Information element description
Establish Bearer (G)MSC-S		Context/Context Request	M	This information element indicates the existing context or requests a new context for the bearer termination.
		Bearer Termination/Bearer Termination Request	M	This information element indicates the existing bearer termination or requests a new bearer termination for the bearer to be established.
		Bearer Establishment Request	M	This information element requests establishment of a bearer.
		Destination Binding Reference	C	This information element indicates the bearer identifier in the destination MGW. This information element shall be included when requesting the establishment of an AAL2 bearer. Otherwise the information element is optional.
		Destination Bearer Address	C	This information element indicates the bearer address of the destination MGW. This information element shall be included when requesting the establishment of an AAL2 bearer. Otherwise the information element is optional.
		Bearer Characteristics	M	This information element indicates the characteristics of the bearer connection.
		Bearer Service Characteristics	C	This information element indicates the bearer service requested by the user. This information element is not included if the Codec information element is provided. It may be included for a non-speech / non SCUDIF multimedia call (see 3GPP TS 23.172 [38], 3GPP TS 29.007 [37] and 3GPP TS 29.232 [6]).
		Notify Bearer Event	O	This information element requests a notification of an established bearer, a released bearer, a modified bearer or a bearer modification failure.
		Tunnel Support	O	This information element indicates the support of tunnel data transfer and when to send tunnel data. In 29.232 this information element is defined in the Tunnel Information down procedure.
	Circuit Switched Data	C	This information element indicates the PLMN bearer capabilities and when applicable GSM channel coding. This information element shall be included according to 3GPP TS 29.007 [37] and 3GPP TS 29.232 [6] for a non-speech / non SCUDIF multimedia call (see 3GPP TS 23.172 [38]) by the MSC server, or by the anchor-MSC in case of inter-MSC handover, for an anchor MGW network termination.	

		Codec	C	This information element indicates the speech coding format to be used for the bearer. This information element is included for a speech call for a network side bearer termination.
		Framing Protocol	O	This information element indicates the framing protocol to be used for the bearer.
		Call Type Discrimination	O	This information element supports modem signalling for GTT feature. NOTE
		Text Telephone	O	This information element supports interworking with PSTN text telephone. NOTE
		Notify termination heartbeat	C	This information element requests termination heartbeat indications. This information element shall be included when requesting a new bearer termination. Otherwise the information element is optional.
		IP Realm Identifier	O	This information element indicates the IP realm of the IP termination.
		Number of desired listener context terminations	O	This information element indicates the number of desired terminations for a listener context in a VGCS or VBS call. It should be included in the first ADD request which establishes a Listener context.
Establish Bearer Ack	MGW	Context	M	This information element indicates the context where the command was executed.
		Bearer Termination	M	This information element indicates the bearer termination where the command was executed.
NOTE: Procedures for use of Text Telephony indication and Call Type discrimination are not defined.				

## 16.2.5 Prepare Bearer

This procedure is used to prepare for a bearer establishment.

**Table 16.6: Procedures between (G)MSC server and MGW: Prepare Bearer**

Procedure	Initiated	Information element name	Information element required	Information element description
Prepare Bearer (G)MSC-S		Context/Context Request	M	This information element indicates the existing context or requests a new context for the bearer termination.
		Bearer Termination Request	M	This information element requests a new bearer termination for the bearer to be established.
		Binding Reference Request	C	This information element requests the bearer identifier in the MGW. This information element shall be included when preparing the establishment of an AAL2 bearer. Otherwise the information element is optional.
		Bearer Address Request	C	This information element requests the bearer address of the MGW. This information element shall be included when preparing the establishment of an AAL2 bearer. Otherwise the information element is optional.
		Sender Binding Reference	O	This information element indicates the bearer identifier of the sending MGW.
		Sender Bearer Address	O	This information element indicates the bearer address of the sending MGW.
		Bearer Characteristics	M	This information element indicates the requested characteristics of the bearer connection.
		Bearer Service Characteristics	C	This information element indicates the bearer service requested by the user. This information element is not included if the Codec information element is provided. It may be included for a data call (see 3GPP TS 29.007 [37] and 3GPP TS 29.232 [6]).
		Notify Bearer Event	O	This information element requests a notification of an established bearer, a released bearer, a modified bearer or a bearer modification failure.
		Notify Bearer Modification	O	This information element requests a notification that bearer modification of the established bearer is allowed. This information element may be included for access bearer assignment.
		Tunnel Support	O	This information element indicates the support of tunnel data transfer and when to send tunnel data. In 3GPP TS 29.232 [6] this information element is defined in the Tunnel Information down procedure.
	Circuit Switched Data	C	This information element indicates the PLMN bearer capabilities and when applicable GSM channel coding and user bit rate. This information element shall be included according to 3GPP TS 29.007 [37] and 3GPP TS 29.232 [6] for a non-speech call by the MSC server, or by the anchor-MSC in case of inter-MSC handover, for a radio access network termination and for an anchor MGW network termination.	

		Codec	C	This information element indicates the speech or multimedia coding format to be used for the bearer. This information element is included for a speech call and may be included for a SCUDIF multimedia call (see 3GPP TS 23.172 [38], 3GPP TS 29.007 [37] and 3GPP TS 29.232 [6]).
		Framing Protocol	O	This information element indicates the framing protocol to be used for the bearer.
		Cellular Text telephony modem	C	This information element indicates the need of CTM function.
		Notify termination heartbeat	M	This information element requests termination heartbeat indications.
		Number of needed conference terminations	O	This information element indicates the number of conference ports needed for that VGCS or VBS call. It shall be included in the first ADD request which establishes the Multiparty context.
		IP Realm Identifier	O	This information element indicates the IP realm of the IP termination.
Prepare Bearer Ack	MGW	Context	M	This information element indicates the context where the command was executed.
		Bearer Termination	M	This information element indicates the bearer termination where the command was executed.
		Binding Reference	C	This information element indicates the bearer identifier in the MGW. This information element is included if requested in the Prepare Bearer request.
		Bearer Address	C	This information element indicates the bearer address of the MGW. This information element is included if requested in the Prepare Bearer request.

## 16.2.6 Reserve Circuit

This procedure is used to select a TDM circuit in the MGW .

**Table 16.7: Procedures between (G)MSC server and MGW: Reserve Circuit**

Procedure	Initiated	Information element name	Information element required	Information element description
Reserve Circuit (G)MSC-S		Context/Context Request	M	This information element indicates the existing context or requests a new context for the bearer termination.
		Bearer Termination	M	This information element indicates the physical bearer termination for the TDM circuit.
		Circuit Switched Data	C	This information element indicates the PLMN bearer capabilities and GSM channel coding. This information element shall be included according to 3GPP TS 29.007 [37] and 3GPP TS 29.232 [6] for a non-speech call by the MSC server, or by the anchor-MSC in case of inter-MSC handover, for a radio access network side bearer termination.
		Bearer Service Characteristics	C	This information element indicates the bearer service requested by the user. This information element is included if no Circuit Switched Data information element is provided.
		Cellular Text telephony modem	C	This information element indicates the need of CTM function.
		Notify Released Bearer	O	This information element requests a notification of a released bearer
		Notify termination heartbeat	O	This information element requests termination heartbeat indications.
		Number of desired listener context terminations	O	This information element indicates the number of desired terminations for a listener context in a VGCS or VBS call. It should be included in the first ADD request which establishes a Listener context.
Reserve Circuit Ack	MGW	Context	M	This information element indicates the context where the command was executed.
		Bearer Termination	M	This information element indicates the bearer termination where the command was executed..

## 16.2.7 Change Through-Connection

This procedure is used to change the through-connection in the bearer termination.

**Table 16.8: Procedures between (G)MSC server and MGW: Change Through-Connection**

Procedure	Initiated	Information element name	Information element required	Information element description
Change Through-Connection	(G)MSC-S	Context/Context Request	M	This information element indicates the existing context or requests a new context for the bearer termination.
		Bearer Termination/Bearer Termination Request	M	This information element indicates the existing bearer termination or requests a new bearer termination where the through-connection is changed.
		Through-Connection	M	This information element indicates the through-connection of the bearer termination.
Change Through-Connection Ack	MGW	Context	M	This information element indicates the context where the command was executed.
		Bearer Termination	M	This information element indicates the bearer termination where the command was executed.

NOTE: This procedure may be combined with Prepare Bearer, Prepare\_IP\_Transport, Establish Bearer, Reserve Circuit, Reserve RTP Connection Point, Configure RTP Connection Point or Reserve and Configure RTP Connection Point, Join Bearer Termination, Isolate Bearer Termination or Release Bearer procedure. This list of procedures is not exhaustive.

## 16.2.8 Activate Interworking Function

This procedure is used to activate the interworking function.

**Table 16.9: Procedures between (G)MSC server and MGW: Activate Interworking Function**

Procedure	Initiated	Information element name	Information element required	Information element description
Activate Interworking Function	(G)MSC-S	Context	M	This information element indicates the context for the bearer termination.
		Bearer Termination	M	This information element indicates the bearer termination where the interworking function is activated.
		Circuit Switched Data Activate	M	This information element requests to activate the interworking function.
		Circuit Switched Data	O	This information element indicates the request for IWF protocol negotiation result and rate change indication.
Activate Interworking Function Ack	MGW	Context	M	This information element indicates the context where the command was executed.
		Bearer Termination	M	This information element indicates the bearer termination where the command was executed.

## 16.2.9 Release Bearer

This procedure is used to release the bearer.

**Table 16.10: Procedures between (G)MSC server and MGW: Release Bearer**

Procedure	Initiated	Information element name	Information element required	Information element description
Release Bearer	(G)MSC-S	Context	M	This information element indicates the context for the bearer termination.
		Bearer Termination	M	This information element indicates the bearer termination for the bearer to be released.
		Bearer Release Request	M	This information element requests release of a bearer.
		Release Cause	O	This information element indicates the cause of a bearer release.
Release Bearer Ack	MGW	Context	M	This information element indicates the context where the command was executed.
		Bearer Termination	M	This information element indicates the bearer termination where the command was executed.

## 16.2.10 Bearer Established

This procedure is used to notify the established bearer.

**Table 16.11: Procedures between (G)MSC server and MGW: Bearer Established**

Procedure	Initiated	Information element name	Information element required	Information element description
Bearer Established	MGW	Context	M	This information element indicates the context for the bearer termination.
		Bearer Termination	M	This information element indicates the bearer termination where the bearer was established.
		Bearer Established	M	This information element notifies a bearer establishment.
Bearer Established Ack	(G)MSC-S	Context	M	This information element indicates the context where the command was executed.
		Bearer Termination	M	This information element indicates the Bearer Termination where the command was executed.

## 16.2.11 Bearer Released

This procedure is used to notify the released bearer or failed bearer establishment.

**Table 16.12: Procedures between (G)MSC server and MGW: Bearer Released**

Procedure	Initiated	Information element name	Information element required	Information element description
Bearer Released	MGW	Context	M	This information element indicates the context for the bearer termination.
		Bearer Termination	M	This information element indicates the bearer termination where the bearer was released.
		Bearer Released	M	This information element notifies a bearer release.
		Release Cause	M	This information element indicates the cause of a bearer release.
Bearer Released Ack	(G)MSC-S	Context	M	This information element indicates the context where the command was executed.
		Bearer Termination	M	This information element indicates the Bearer Termination where the command was executed.

## 16.2.12 Release Termination

This procedure is used to release the bearer termination.

**Table 16.13: Procedures between (G)MSC server and MGW: Release Termination**

Procedure	Initiated	Information element name	Information element required	Information element description
Release Termination	(G)MSC-S	Context	M	This information element indicates the context for the bearer termination.
		Bearer Termination	M	This information element indicates the bearer termination to be released.
Release Termination Ack	MGW	Context	M	This information element indicates the context where the command was executed.
		Bearer Termination	M	This information element indicates the bearer termination where the command was executed.
		T.140 data statistics	C	Number of t.140 data bits transmitted over the termination



## 16.2.13 Tunnel Information Up

This procedure is used to transfer tunnel data from the MGW to the (G)MSC server.

**Table 16.14: Procedures between (G)MSC server and MGW: Tunnel Information Up**

Procedure	Initiated	Information element name	Information element required	Information element description
Tunnel Information Up	MGW	Context	M	This information element indicates the context for the bearer termination.
		Bearer Termination	M	This information element indicates the bearer termination from where the tunnel data is sent.
		Tunnel Data	M	This information element contains the tunnel data that is provided between MGWs.
Tunnel InformationUp Ack	(G)MSC-S	Context	M	This information element indicates the context where the command was executed.
		Bearer Termination	M	This information element indicates the Bearer Termination where the command was executed.

## 16.2.14 Tunnel Information Down

This procedure is used to transfer tunnel data from the (G)MSC server to the MGW.

**Table 16.15: Procedures between (G)MSC server and MGW: Tunnel Information**

Procedure	Initiated	Information element name	Information element required	Information element description
Tunnel Information Down	(G)MSC-S	Context	M	This information element indicates the context for the bearer termination.
		Bearer Termination	M	This information element indicates the bearer termination where to the tunnel data is sent.
		Tunnel Data	M	This information element contains the tunnel data that is provided between MGWs.
Tunnel Information Down Ack	MGW	Context	M	This information element indicates the context where the command was executed.
		Bearer Termination	M	This information element indicates the bearer termination where the command was executed.

NOTE: This procedure may be combined with Prepare Bearer or Establish Bearer procedure.

## 16.2.15 Send Tone

This procedure is used to send a tone.

**Table 16.16: Procedures between (G)MSC server and MGW: Send Tone**

Procedure	Initiated	Information element name	Information element required	Information element description
Send Tone (G)MSC-S		Context	M	This information element indicates the context for the bearer termination.
		Bearer Termination/Bearer Termination Request	M	This information element indicates the existing bearer termination or requests a new bearer termination where the tone is sent.
		Tone	M	This information element indicates the tone to be generated.
		Notify Tone Completion	O	This information element requests a notification of a completed tone.
		Tone Direction	O	This information element indicates the tone direction in the bearer termination.
		Tone Timing	O	This information element indicates the time for the tone.
		Notify termination heartbeat	C	This information element requests termination heartbeat indications. This information element shall be included when requesting a new ephemeral bearer termination.
Send Tone Ack	MGW	Context	M	This information element indicates the context where the command was executed.
		Bearer Termination	M	This information element indicates the bearer termination where the command was executed.

NOTE: This procedure may be combined with Join Bearer Termination or Isolate Bearer Termination procedure.

## 16.2.16 Stop Tone

This procedure is used to stop the tone.

**Table 16.17: Procedures between (G)MSC server and MGW: Stop Tone**

Procedure	Initiated	Information element name	Information element required	Information element description
Stop Tone	(G)MSC-S	Context	M	This information element indicates the context for the bearer termination.
		Bearer Termination	M	This information element indicates the bearer termination where the tone is stopped.
		Stop Tone	M	This information element requests that tone generation is stopped.
Stop Tone Ack	MGW	Context	M	This information element indicates the context where the command was executed.
		Bearer Termination	M	This information element indicates the bearer termination where the command was executed.

## 16.2.17 Play Announcement

This procedure is used to play an announcement.

**Table 16.18: Procedures between (G)MSC server and MGW: Play Announcement**

Procedure	Initiated	Information element name	Information element required	Information element description
Play Announcement (G)MSC-S		Context	M	This information element indicates the context for the bearer termination.
		Bearer Termination/Bearer Termination Request	M	This information element indicates the existing bearer termination or requests a new bearer termination where the announcement is sent.
		Announcement	M	This information element indicates the announcement to be played.
		Notify Announcement Completion	O	This information element requests a notification of a completed announcement.
		Announcement Direction	O	This information element indicates the announcement direction in the bearer termination.
		Announcement Timing	O	This information element indicates the time for the announcement.
		Notify termination heartbeat	C	This information element requests termination heartbeat indications. This information element shall be included when requesting a new ephemeral bearer termination.
Play Announcement Ack	MGW	Context	M	This information element indicates the context where the command was executed.
		Bearer Termination	M	This information element indicates the bearer termination where the command was executed.

NOTE: This procedure may be combined with Join Bearer Termination or Isolate Bearer Termination procedure.

## 16.2.18 Stop Announcement

This procedure is used to stop the announcement.

**Table 16.19: Procedures between (G)MSC server and MGW: Stop Announcement**

Procedure	Initiated	Information element name	Information element required	Information element description
Stop Announcement	(G)MSC-S	Context	M	This information element indicates the context for the bearer termination.
		Bearer Termination	M	This information element indicates the bearer termination where the announcement is stopped.
		Stop Announcement	M	This information element requests that announcement playing is stopped.
Stop Announcement Ack	MGW	Context	M	This information element indicates the context where the command was executed.
		Bearer Termination	M	This information element indicates the bearer termination where the command was executed.

## 16.2.19 Announcement Completed

This procedure is used to notify the completed announcement.

**Table 16.20: Procedures between (G)MSC server and MGW: Announcement Completed**

Procedure	Initiated	Information element name	Information element required	Information element description
Announcement Completed	MGW	Context	M	This information element indicates the context for the bearer termination.
		Bearer Termination	M	This information element indicates the bearer termination where the announcement was completed.
		Announcement Completed	M	This information element indicates completion of the announcement.
Announcement Completed Ack	(G)MSC-S	Context	M	This information element indicates the context where the command was executed.
		Bearer Termination	M	This information element indicates the Bearer Termination where the command was executed.

## 16.2.20 Tone Completed

This procedure is used to notify the completed tone.

**Table 16.21: Procedures between (G)MSC server and MGW: Tone Completed**

Procedure	Initiated	Information element name	Information element required	Information element description
Tone Completed	MGW	Context	M	This information element indicates the context for the bearer termination.
		Bearer Termination	M	This information element indicates the bearer termination where the tone was completed.
		Tone Completed	M	This information element indicates completion of the tone.
Tone Completed Ack	(G)MSC-S	Context	M	This information element indicates the context where the command was executed.
		Bearer Termination	M	This information element indicates the Bearer Termination where the command was executed.

## 16.2.21 Detect DTMF

This procedure is used to request detection of a DTMF tone.

**Table 16.22: Procedures between (G)MSC server and MGW: Detect DTMF**

Procedure	Initiated	Information element name	Information element required	Information element description
Detect DTMF	(G)MSC-S	Context	M	This information element indicates the context for the bearer termination.
		Bearer Termination/Bearer Termination Request	M	This information element indicates the existing bearer termination or requests a new bearer termination where the DTMF tone detection is requested.
		Digit	M	This information element requests MGW to detect a DTMF tone.
Detect DTMF Ack	MGW	Context	M	This information element indicates the context where the command was executed.
		Bearer Termination	M	This information element indicates the bearer termination where the command was executed.

**NOTE** This procedure may be combined with Prepare Bearer, Prepare\_IP\_Transport, Establish Bearer, Reserve Circuit, Reserve RTP Connection Point procedure, Configure RTP Connection Point or Reserve and Configure RTP Connection Point. This list of procedures is not exhaustive.

## 16.2.22 Stop DTMF Detection

This procedure is used to stop detection of the DTMF tone.

**Table 16.23: Procedures between (G)MSC server and MGW: Stop DTMF Detection**

Procedure	Initiated	Information element name	Information element required	Information element description
Stop DTMF Detection	(G)MSC-S	Context	M	This information element indicates the context for the bearer termination.
		Bearer Termination	M	This information element indicates the bearer termination where the DTMF tone detection is stopped.
		Stop DTMF Detection	M	This information element requests that DTMF tone detection is stopped.
Stop DTMF Detection Ack	MGW	Context	M	This information element indicates the context where the command was executed.
		Bearer Termination	M	This information element indicates the bearer termination where the command was executed.

## 16.2.23 Report DTMF

This procedure is used to report a detected DTMF tone.

**Table 16.24: Procedures between (G)MSC server and MGW: Report DTMF**

Procedure	Initiated	Information element name	Information element required	Information element description
Report DTMF	MGW	Context	M	This information element indicates the context for the bearer termination.
		Bearer Termination	M	This information element indicates the bearer termination where the DTMF tone was detected.
		Digit	M	This information element reports the detected DTMF tone.
Report DTMF Ack	(G)MSC-S	Context	M	This information element indicates the context where the command was executed.
		Bearer Termination	M	This information element indicates the Bearer Termination where the command was executed.

## 16.2.24 Send DTMF

This procedure is used to request sending of a DTMF tone.

**Table 16.25: Procedures between (G)MSC server and MGW: Send DTMF**

Procedure	Initiated	Information element name	Information element required	Information element description
Send DTMF	(G)MSC-S	Context	M	This information element indicates the context for the bearer termination.
		Bearer Termination/Bearer Termination Request	M	This information element indicates the existing bearer termination or requests a new bearer termination where the DTMF tone generation is requested.
		Digit	M	This information element requests MGW to generate a DTMF tone.
		DTMF Tone Timing	O	This information element indicates the time for the DTMF tone in the bearer termination.
Send DTMF Ack	MGW	Context	M	This information element indicates the context where the command was executed.
		Bearer Termination	M	This information element indicates the bearer termination where the command was executed.

## 16.2.25 Stop DTMF

This procedure is used to stop sending of the DTMF tone.

**Table 16.26: Procedures between (G)MSC server and MGW: Stop DTMF**

Procedure	Initiated	Information element name	Information element required	Information element description
Stop DTMF	(G)MSC-S	Context	M	This information element indicates the context for the bearer termination.
		Bearer Termination	M	This information element indicates the bearer termination where the DTMF tone generation is stopped.
		Stop DTMF	M	This information element requests that DTMF tone generation is stopped.
Stop DTMF Ack	MGW	Context	M	This information element indicates the context where the command was executed.
		Bearer Termination	M	This information element indicates the bearer termination where the command was executed.

## 16.2.26 MGW Out-of-Service/ Maintenance locking

This procedure is used to indicate that the MGW will go out of service or is maintenance locked.

**Table 16.27: Procedures between (G)MSC server and MGW: MGW Out-of-Service or Maintenance Locked**

Procedure	Initiated	Information element name	Information element required	Information element description
MGW Out-of-Service/ Maintenance locked	MGW	Context	M	This information element indicates the context for the command.
		Root Termination	M	This information element indicates the root termination for the command.
		Reason	M	This information element indicates the reason for service change.
		Method	M	This information element indicates the method for service change.
MGW Out-of-Service/ Maintenance locked Ack	(G)MSC-S	Context	M	This information element indicates the context where the command was executed.
		Root Termination	M	This information element indicates the root termination where the command was executed.

## 16.2.27 MGW Communication Up

This procedure is used to indicate that the MGW is back in service.

**Table 16.28: Procedures between (G)MSC server and MGW: MGW Communication Up**

Procedure	Initiated	Information element name	Information element required	Information element description
MGW Communication Up	MGW	Context	M	This information element indicates the context for the command.
		Root Termination	M	This information element indicates the root termination for the command.
		Reason	M	This information element indicates the reason for service change.
		Method	M	This information element indicates the method for service change.
MGW Communication Up Ack (G)MSC-S		Context	M	This information element indicates the context where the command was executed.
		Root Termination	M	This information element indicates the root termination where the command was executed.
		(G)MSC-S Address	O	This information element indicates the (G)MSC server signalling address to which the MGW should preferably attempt to re-register.

## 16.2.28 MGW Restoration

This procedure is used to indicate the MGW failure or recovery.

**Table 16.29: Procedures between (G)MSC server and MGW: MGW Restoration**

Procedure	Initiated	Information element name	Information element required	Information element description
MGW Restoration	MGW	Context	M	This information element indicates the context for the command.
		Root Termination	M	This information element indicates the root termination for the command.
		Reason	M	This information element indicates the reason for the service change.
		Method	M	This information element indicates the method for service change.
MGW Restoration Ack (G)MSC-S		Context	M	This information element indicates the context where the command was executed.
		Root Termination	M	This information element indicates the root termination where the command was executed.
		(G)MSC-S Address	O	This information element indicates the (G)MSC server signalling address to which the MGW should preferably attempt to re-register.



## 16.2.29 MGW Register

This procedure is used to register the MGW.

**Table 16.30: Procedures between (G)MSC server and MGW: MGW Register**

Procedure	Initiated	Information element name	Information element required	Information element description
MGW Register	MGW	Context	M	This information element indicates the context for the command.
		Root Termination	M	This information element indicates the root termination for the command.
		Reason	M	This information element indicates the reason for the service change.
		Method	M	This information element indicates the method for service change.
		Protocol Version	M	This information element indicates the protocol version for Mc interface requested by the MGW.
		Service Change Profile	M	This information element indicates the profile for the Mc interface requested by the MGW.
MGW Register Ack (G)MSC-S		Context	M	This information element indicates the context where the command was executed.
		Root Termination	M	This information element indicates the root termination where the command was executed.
		Protocol Version	O	This information element indicates the protocol version for Mc interface supported by the (G)MSC server.
		Service Change Profile	O	This information element indicates the profile for the Mc interface supported by the (G)MSC Server.
		(G)MSC-S Address	O	This information element indicates the (G)MSC server signalling address to which the MGW should preferably attempt to re-register.

### 16.2.30 MGW Re-register

This procedure is used to re-register the MGW.

**Table 16.31: Procedures between (G)MSC server and MGW: MGW Re-register**

Procedure	Initiated	Information element name	Information element required	Information element description
MGW Re-register	MGW	Context	M	This information element indicates the context for the command.
		Root Termination	M	This information element indicates the root termination for the command.
		Reason	M	This information element indicates the reason for the service change.
		Method	M	This information element indicates the method for service change.
		Protocol Version	M	This information element indicates the protocol version for Mc interface requested by the MGW.
		Service Change Profile	M	This information element indicates the profile for the Mc interface requested by the MGW.
MGW Re-register Ack (G)MSC-S		Context	M	This information element indicates the context where the command was executed.
		Root Termination	M	This information element indicates the root termination where the command was executed.
		Protocol Version	O	This information element indicates the protocol version for Mc interface supported by the (G)MSC server.
		Service Change Profile	O	This information element indicates the profile for the Mc interface supported by the (G)MSC Server.
		(G)MSC-S Address	O	This information element indicates the (G)MSC server signalling address to which the MGW should preferably attempt to re-register.

### 16.2.31 (G)MSC Server Ordered Re-register

This procedure is used by the (G)MSC server to request the MGW to register itself.

**Table 16.32: Procedures between (G)MSC server and MGW: (G)MSC Server Ordered Re-register**

Procedure	Initiated	Information element name	Information element required	Information element description
(G)MSC Server Ordered Re-register	(G)MSC-S	Context	M	This information element indicates the context for the command.
		Root Termination	M	This information element indicates the root termination for the command.
		Reason	M	This information element indicates the reason for the service change.
		(G)MSC-S Address	O	This information element indicates the (G)MSC server signalling address.
(G)MSC Server Ordered Re-register Ack	MGW	Context	M	This information element indicates the context where the command was executed.
		Root Termination	M	This information element indicates the root termination where the command was executed.

## 16.2.32 (G)MSC Server Restoration

This procedure is used to indicate the (G)MSC server failure or recovery.

**Table 16.33: Procedures between (G)MSC server and MGW: (G)MSC Server Restoration**

Procedure	Initiated	Information element name	Information element required	Information element description
(G)MSC Server Restoration	(G)MSC-S	Context	M	This information element indicates the context for the command.
		Root Termination	M	This information element indicates the root termination for the command.
		Reason	M	This information element indicates the reason for the service change.
		Method	M	This information element indicates the method for service change.
(G)MSC Server Restoration Ack	MGW	Context	M	This information element indicates the context where the command was executed.
		Root Termination	M	This information element indicates the root termination where the command was executed.

## 16.2.33 (G)MSC Server Out of Service

This procedure is used to indicate that (G)MSC server has gone out of service.

**Table 16.34: Procedures between (G)MSC server and MGW: (G)MSC Server Out of Service**

Procedure	Initiated	Information element name	Information element required	Information element description
(G)MSC Server Out of Service	(G)MSC-S	Context	M	This information element indicates the context for the command.
		Root Termination	M	This information element indicates the root termination for the command.
		Reason	M	This information element indicates the reason for the service change.
		Method	M	This information element indicates the method for service change.
(G)MSC Server Out of Service Ack	MGW	Context	M	This information element indicates the context where the command was executed.
		Root Termination	M	This information element indicates the root termination where the command was executed.

## 16.2.34 Termination Out-of-Service

This procedure is used to indicate that physical termination(s) will go out of service.

**Table 16.35: Procedures between (G)MSC server and MGW: Termination Out-of-Service**

Procedure	Initiated	Information element name	Information element required	Information element description
Termination Out-of-Service	MGW	Context	M	This information element indicates the context for the command.
		Bearer Termination	M	This information element indicates the bearer termination(s) for the command.
		Reason	M	This information element indicates the reason for service change.
		Method	M	This information element indicates the method for service change.
Termination Out-of-Service Ack	(G)MSC-S	Context	M	This information element indicates the context where the command was executed.
		Bearer Termination	M	This information element indicates the bearer termination where the command was executed.

## 16.2.35 Termination Restoration

This procedure is used to indicate that physical termination(s) are back in service.

**Table 16.36: Procedures between (G)MSC server and MGW: Termination Restoration**

Procedure	Initiated	Information element name	Information element required	Information element description
Termination Restoration	MGW	Context	M	This information element indicates the context for the command.
		Bearer Termination	M	This information element indicates the bearer termination(s) for the command.
		Reason	M	This information element indicates the reason for service change.
		Method	M	This information element indicates the method for service change.
Termination Restoration Ack	(G)MSC-S	Context	M	This information element indicates the context where the command was executed.
		Bearer Termination	M	This information element indicates the bearer termination where the command was executed.

## 16.2.36 Audit Value

This procedure is used to audit values of different object(s).

**Table 16.37: Procedures between (G)MSC server and MGW: Audit Value**

Procedure	Initiated	Information element name	Information element required	Information element description
Audit Value	(G)MSC-S	Context	M	This information element indicates the context for the command.
		Bearer Termination	M	This information element indicates the bearer termination(s) for the command.
		Object(s)	M	This information element indicates the object(s) to be audited.
Audit Value Ack	MGW	Context	M	This information element indicates the context where the command was executed.
		Bearer Termination	M	This information element indicates the bearer termination where the command was executed.
		Value(s)	M	This information element indicates the value(s) of the object(s).

## 16.2.37 Audit Capability

This procedure is used to audit capabilities of different object(s).

**Table 16.38: Procedures between (G)MSC server and MGW: Audit Capability**

Procedure	Initiated	Information element name	Information element required	Information element description
Audit Capability	(G)MSC-S	Context	M	This information element indicates the context for the command.
		Bearer Termination	M	This information element indicates the bearer termination(s) for the command.
		Object(s)	M	This information element indicates the object(s) which capability is requested.
Audit Capability Ack	MGW	Context	M	This information element indicates the context where the command was executed.
		Bearer Termination	M	This information element indicates the bearer termination where the command was executed.
		Capabilities(s)	M	This information element indicates the capabilities of the object(s).

## 16.2.38 Capability Update

This procedure is used to indicate update of an object capability.

**Table 16.39: Procedures between (G)MSC server and MGW: Capability Update**

Procedure	Initiated	Information element name	Information element required	Information element description
Capability Update	MGW	Context	M	This information element indicates the context for the command.
		Bearer Termination	M	This information element indicates the bearer termination(s) for the command.
		Reason	M	This information element indicates the reason for service change.
		Method	M	This information element indicates the method for service change.
Capability Update Ack	(G)MSC-S	Context	M	This information element indicates the context where the command was executed.
		Bearer Termination	M	This information element indicates the bearer termination where the command was executed.

## 16.2.39 Command Reject

This command is used to reject the received command request. It may be used as response to any of the above procedures.

**Table 16.40: Procedures between (G)MSC server and MGW: Command Reject**

Procedure	Initiated	Information element name	Information element required	Information element description
Command Reject	Both	Context	M	This information element indicates the context where the command was rejected.
		Bearer Termination	M	This information element indicates the bearer termination where the command was rejected.
		Error	M	This information element indicates the error that caused command rejection.

## 16.2.40 Activate Voice Processing Function

This procedure is used to activate the voice processing (echo cancellation) function.

**Table 16.41: Procedures between (G)MSC server and MGW: Activate Voice Processing Function**

Procedure	Initiated	Information element name	Information element required	Information element description
Activate Voice Processing Function	(G)MSC-S	Context	M	This information element indicates the context for the bearer termination.
		Bearer Termination	M	This information element indicates the bearer termination where the voice processing function is activated.
		Activate Voice Processing Function	M	This information element requests to activate the voice processing function.
Activate Voice Processing Function Ack	MGW	Context	M	This information element indicates the context where the command was executed.
		Bearer Termination	M	This information element indicates the bearer termination where the command was executed.

## 16.2.41 Modify Bearer Characteristics

This procedure is used to modify the bearer characteristics.

**Table 16.42: Procedures between (G)MSC server and MGW: Modify Bearer Characteristics**

Procedure	Initiated	Information element name	Information element required	Information element description
Modify Bearer Characteristics	(G)MSC-S	Context	M	This information element indicates the existing context for the bearer termination.
		Bearer Termination	M	This information element indicates the bearer termination for the bearer to be modified.
		Bearer Service Characteristics	C	This information element indicates the bearer service requested by the user. This information element is not included if the Codec information element is provided. It may be included for a data call (see 3GPP TS 29.007 [37] and 3GPP TS 29.232 [6]).
		Circuit Switched Data	C	This information element indicates the PLMN bearer capabilities and when applicable GSM channel coding and user bit rate. This information element shall be included according to 3GPP TS 29.007 [37] and 3GPP TS 29.232 [6] for a non-speech call by the MSC server, or by the anchor-MSC in case of inter-MSC handover, for UMTS radio access network side bearer termination and for network side bearer termination.
		Codec	C	This information element indicates the speech or multimedia coding format to be used for the bearer. This information element is included for the speech call and may be included for a SCUDIF multimedia call (see 3GPP TS 23.172 [38], 3GPP TS 29.007 [37] and 3GPP TS 29.232 [6]), for UMTS radio access network side bearer termination and for network side bearer termination.
		Framing Protocol	O	This information element indicates the framing protocol to be used for the bearer.
Modify Bearer Characteristics Ack	MGW	Context	M	This information element indicates the context where the command was executed.
		Bearer Termination	M	This information element indicates the bearer termination where the command was executed.



## 16.2.42 Protocol Negotiation Result

This procedure is used to inform the MSC about protocol negotiation result.

**Table 16.43: Procedures between MSC server and MGW: Protocol Negotiation Result**

Procedure	Initiated	Information element name	Information element required	Information element description
IWF Protocol Indication	MGW	Context	M	This information element indicates the existing context for the bearer termination.
		Bearer Termination	M	This information element indicates the bearer termination for the bearer to be modified.
		Protocol Negotiation result	M	This information element indicates the IWF protocol negotiation result
IWF Protocol Indication Ack	MSC	Context	M	This information element indicates the context where the command was executed.
		Bearer Termination	M	This information element indicates the bearer termination where the command was executed.

## 16.2.43 MGW Resource Congestion Handling - Activate

This procedure is used to activate the congestion handling mechanism.

**Table 16.44: Procedures between (G)MSC server and MGW: MGW Resource Congestion Handling - Activate**

Procedure	Initiated	Information element name	Information element required	Information element description
MGW Resource Congestion Handling – Activate	(G)MSC-S	Context	M	This information element indicates that all context are applicable for the root termination.
		Root Termination	M	This information element indicates that root termination is where the congestion mechanism is activated.
		Congestion Activate	M	This information element requests to activate the congestion mechanism.
MGW Resource Congestion Handling - Activate Ack	MGW	Context	M	This information element indicates that all context are where the command was executed.
		Root Termination	M	This information element indicates that root termination is where the command was executed.

## 16.2.44 MGW Resource Congestion Handling - Indication

This procedure is used to inform the (G)MSC server that traffic restriction is advised.

**Table 16.45: Procedures between (G)MSC server and MGW: MGW Resource Congestion Handling - Indication**

Procedure	Initiated	Information element name	Information element required	Information element description
MGW Resource Congestion Handling - Indication	MGW	Context	M	This information element indicates all context are applicable for the root termination.
		Root Termination	M	This information element indicates that root termination is where the congestion mechanism was activated.
		Reduction	M	This information element indicates the load percentage to be reduced.
MGW Resource Congestion Handling - Indication Ack	(G)MSC	Context	M	This information element indicates all context are where the command was executed.
		Root Termination	M	This information element indicates that root termination is where the command was executed.

## 16.2.45 Bearer Modification Support

This procedure is used to notify that the established bearer can be modified.

**Table 16.46: Procedures between (G)MSC server and MGW: Bearer Modification**

Procedure	Initiated	Information element name	Information element required	Information element description
Bearer Modification Support	MGW	Context	M	This information element indicates the context for the bearer termination.
		Bearer Termination	M	This information element indicates the bearer termination where the bearer was established.
		Bearer Modification	M	This information element notifies that the established bearer can be modified.
Bearer Modification Support Ack	(G)MSC-S	Context	M	This information element indicates the context where the command was executed.
		Bearer Termination	M	This information element indicates the Bearer Termination where the command was executed.

## 16.2.46 CTM report

This procedure is used to notify the outcome of the CTM negotiation in the user plane.

**Table 16.47: Procedures between (G)MSC server and MGW: CTM report**

Procedure	Initiated	Information element name	Information element required	Information element description
CTM report	MGW	Context	M	This information element indicates the context for the bearer termination.
		Bearer Termination	M	This information element indicates the bearer termination where the CTM function was activated
		Outcome of CTM negotiation	M	This information element indicates whether the CTM negotiation in user plane was successful or not.
CTM report Ack	(G)MSC-S	Context	M	This information element indicates the context where the command was executed.
		Bearer Termination	M	This information element indicates the Bearer Termination where the command was executed.

## 16.2.47 Prepare\_IP\_Transport

This procedure is used to prepare for a bearer establishment when IuCS on IP is supported by the MSC.

**Table 16.48: Procedures between (G)MSC server and MGW: Prepare\_IP\_Transport**

Procedure	Initiated	Information element name	Information element required	Information element description
Prepare_IP_Transport (G)MSC-S		Context/Context Request	M	This information element indicates the existing context or requests a new context for the IP Access bearer termination.
		Bearer Termination Request	M	This information element requests a new bearer termination for the IP Access bearer to be established.
		Iu UDP Port Request	M	This information element requests the Iu UDP Port in the MGW
		IP Transport Address Request	M	This information element requests the IP address of the MGW.
		Bearer Characteristics/ Bearer Characteristics Requests	M	This information element indicates the preferred characteristics of the bearer connection or requests the MGW to select and provide the bearer characteristics.
		Bearer Service Characteristics	C	This information element indicates the bearer service requested by the user. This information element is not included if the Codec information element is provided. It may be included for a data call (see 3GPP TS 29.007 [37] and 3GPP TS 29.232 [6]).
		Notify Bearer Event	O	This information element requests a notification of an established bearer, a released bearer, a modified bearer or a bearer modification failure.
		Circuit Switched Data	C	This information element indicates the PLMN bearer capabilities and when applicable the user bit rate. This information element shall be included according to 3GPP TS 29.007 [37] and 3GPP TS 29.232 [6] for a non-speech call by the MSC server, or by the anchor-MSC in case of inter-MSC handover, for a UMTS radio access network side bearer termination.
		Codec	C	This information element indicates the speech or multimedia coding format to be used for the bearer. This information element is included for a speech call and may be included for a SCUDIF multimedia call (see 3GPP TS 23.172 [38], 3GPP TS 29.007 [37] and 3GPP TS 29.232 [6]), for a UMTS radio access network side bearer termination.
		Framing Protocol	O	This information element indicates the framing protocol to be used for the bearer.
		Cellular Text telephony modem	C	This information element indicates the need of CTM function.
		IP Realm Identifier	O	This information element indicates the IP realm of the IP termination.
Notify termination heartbeat	M	This information element requests termination heartbeat indications.		
Prepare IP Transport Ack	MGW	Context	M	This information element indicates the context where the command was executed.
		Bearer Termination	M	This information element indicates the bearer termination where the command was executed.
		IP Transport Address	M	This information element indicates the IP address of the MGW

		Iu UDP Port	M	This information element requests the Iu UDP Port in the MGW
--	--	-------------	---	--

## 16.2.48 Modify IP Transport Address

This procedure is used when IuCS on IP is supported by the MGW and IuUP in transparent mode is configured.

**Table 16.49: Procedures between (G)MSC server and MGW: RNC IP address notification**

Procedure	Initiated	Information element name	Information element required	Information element description
Modify IP Transport Address	MSC-S	Context	M	This information element indicates the context for the IP bearer termination.
		Bearer Termination	M	This information element indicates the IP bearer termination where the RNC IP Address is needed.
		IP Transport address	M	This information element indicates the IP address of the RNC
		Iu UDP Port	M	This information element indicates the Iu UDP Port in the RNC
Modify IP Address Ack	MGW	Context	M	This information element indicates the context where the command was executed.
		Bearer Termination	M	This information element indicates the IP bearer termination where the command is executed.

## 16.2.49 Emergency Call Indication

This procedure is used to indicate that the call is an emergency call.

**Table 16.50: Procedures between (G)MSC server and MGW: Emergency Call Indication**

Procedure	Initiated	Information element name	Information element required	Information element description
Emergency Call Indication	(G)MSC-S	Context Request	M	This information element indicates the existing context or requests a new context for the bearer termination.
		Emergency Call Indicator	M	This information element indicates the emergency call information
Emergency Call Indication Ack	MGW	Context	M	This information element indicates the context where the command was executed.

## 16.2.50 Trace Activation

This procedure is used for activation of a Trace Session in a MGW.

**Table 16.51: Procedures between (G)MSC server and MGW: Trace Activation**

Procedure	Initiated	Information element name	Information element required	Information element description
Trace Activation	MSC-S	Context	M	This information element indicates the context for the command.
		Bearer Termination	M	This information element indicates the bearer termination(s) for the command.
		Trace Reference	C	Defined in 3GPP TS 32.421 and 3GPP TS 32.422
		Trace Session Recording Reference	C	Defined in 3GPP TS 32.421 and 3GPP TS 32.422
		Triggering Events	C	Defined in 3GPP TS 32.421 and 3GPP TS 32.422
		Trace Depth	C	Defined in 3GPP TS 32.421 and 3GPP TS 32.422
		List of interfaces	O	Defined 3GPP TS 32.422
		Trace Activity Control	M	This information element indicates the trace activation)
		IMSI	C	This information element shows the IMSI of the traced subscriber. Either IMSI or IMEI(SV) must be provided.
		IMEI(SV)	C	This information element shows the IMEI(SV) of the traced equipment. Either IMSI or IMEI(SV) must be provided.
Notify Trace Activation result	O	This information element requests a notification of the result of the trace activation.		
Trace Activation Reply	MGW	Context	M	This information element indicates the context where the command was executed.
		Bearer Termination	M	This information element indicates the bearer termination where the command was executed.

## 16.2.51 Trace Deactivation

This procedure is used for deactivation of a Trace Session in a MGW..

**Table 16.52: Procedures between (G)MSC server and MGW: Trace Deactivation**

Procedure	Initiated	Information element name	Information element required	Information element description
Trace Deactivation	MSC-S	Context	M	This information element indicates the context for the command.
		Bearer Termination	M	This information element indicates the bearer termination(s) for the command.
		Trace Reference	M	Defined in 3GPP TS 32.421 and 3GPP TS 32.422
		Trace Activity Control	M	This information element indicates the trace deactivation
Trace Deactivation Reply	MGW	Context	M	This information element indicates the context where the command was executed.
		Bearer Termination	M	This information element indicates the bearer termination where the command was executed

## 16.2.52 Trace Activation result notification

This procedure is used for informing the MSC Server about the result of the Trace Session Activation.

**Table 16.53: Procedures between MGW and (G)MSC Server: Trace Activation result notification**

Procedure	Initiated	Information element name	Information element required	Information element description
Trace Activation result notification	MGW	Context	M	This information element indicates the context for the command
		Bearer Termination	M	This information element indicates the bearer termination(s) for the command
		Result	M	This information element defines the result of the Trace Session Activation
Trace Activation result notification Ack	MSC-S	Context	M	This information element indicates the context where the command was executed
		Bearer Termination	M	This information element indicates the bearer termination where the command was executed.

## 16.2.53 Continuity Check Tone

This procedure is used by the (G)MSC to order the MGW to generate a continuity check tone at a TDM termination and to inform the (G)MSC about the result of the continuity check as soon as the continuity check tone is received or a time-out occurs.

**Table 16.54: Continuity Check Tone procedure**

Procedure	Initiated	Information element name	Information element required	Information element description
Continuity Check Tone	(G)MSC	Context/Context Request	M	This information element indicates the existing context or requests a new context for the bearer termination.
		TDM Termination	M	This information element indicates the bearer termination
		Request for continuity tone sending	M	This information request the MGW to apply the continuity check procedure on the indicated TDM termination
		Request for continuity check tone detection	M	This information request the MGW to inform of result of the continuity check procedure on the indicated TDM termination
Continuity Check Tone Ack	IMGW	Context	M	This information element indicates the context where the command was executed.

## 16.2.54 Continuity Check Verify

This procedure is used by the MGW to indicate towards the (G)MSC that the continuity check at a TDM termination has been completed and to return the result of the check: success or failure.

**Table 16.55: Continuity Check Verify procedure**

Procedure	Initiated	Information element name	Information element required	Information element description
Continuity check Verify	MGW	Context/t	M	This information element indicates the context where the command was executed.
		TDM Termination	M	This information element indicates the TDM termination involved in the procedure
		Outcome of the continuity check	M	This information element indicates the outcome of the continuity check (successful/unsuccessful)
Continuity Check Verify Ack	(G)MSC	Context	M	This information element indicates the context where the command was executed.

### 16.2.55 Continuity Check Response

This procedure is used by the (G)MSC to order the MGW to loop back an incoming continuity check tone at a TDM termination.

**Table 16.56: Continuity Check Response procedure**

Procedure	Initiated	Information element name	Information element required	Information element description
Continuity Check Response	(G)MSC	Context/Context Request	M	This information element indicates the existing context or requests a new context for the bearer termination.
		TDM Termination	M	This information element indicates the bearer termination
		Request for loop back of the continuity tone	M	This information request the MGW to loop back the continuity check tone on the indicated TDM termination
Continuity Check Response Ack	IMGW	Context	M	This information element indicates the context where the command was executed.

### 16.2.56 Rate Change

This procedure is used to notify that the CS data rate should be changed.

**Table 16.57: Procedures between (G)MSC server and MGW: Rate Change**

Procedure	Initiated	Information element name	Information element required	Information element description
Rate Change	MGW	Context	M	This information element indicates the context for the bearer termination.
		Bearer Termination	M	This information element indicates the bearer termination where the rate change is required.
		Rate	M	This information element notifies the current rate.
Rate Change Ack	(G)MSC-S	Context	M	This information element indicates the context where the command was executed.
		Bearer Termination	M	This information element indicates the bearer termination where the command was executed.



## 16.2.57 Bearer Modified

This procedure is used to notify the modified bearer.

**Table 16.2.57/1: Procedures between (G)MSC server and MGW: Bearer Modified**

Procedure	Initiated	Information element name	Information element required	Information element description
Bearer Modified	MGW	Context	M	This information element indicates the context for the bearer termination.
		Bearer Termination	M	This information element indicates the bearer termination where the bearer was modified.
		Bearer Modified	M	This information element notifies a bearer modification.
Bearer Modified Ack	(G)MSC-S	Context	M	This information element indicates the context where the command was executed.
		Bearer Termination	M	This information element indicates the bearer termination where the command was executed.

## 16.2.58 Bearer Modification Failed

This procedure is used to notify the failed bearer modification.

**Table 16.2.58/1: Procedures between (G)MSC server and MGW: Bearer Modification failed**

Procedure	Initiated	Information element name	Information element required	Information element description
Bearer Modification Failed	MGW	Context	M	This information element indicates the context for the bearer termination.
		Bearer Termination	M	This information element indicates the bearer termination where the bearer modification failed.
		Bearer Modification failure	M	This information element notifies a bearer modification failure
Bearer Modification Failed Ack	(G)MSC-S	Context	M	This information element indicates the context where the command was executed.
		Bearer Termination	M	This information element indicates the bearer termination where the command was executed.

## 16.2.59 Termination heartbeat indication

This procedure is used to report indication of hanging termination.

**Table 16.2.59/1: Procedures between (G)MSC server and MGW: Hanging termination indication**

Procedure	Initiated	Information element name	Information element required	Information element description
Termination heartbeat indication	MGW	Context	M	This information element indicates the context for the bearer termination.
		Bearer Termination	M	This information element indicates the bearer termination for which the termination heartbeat is reported.
		Termination heartbeat	M	Hanging termination event as defined in 3GPP TS 29.232 [6].
Termination heartbeat indication Ack	(G)MSC-S	Context	M	This information element indicates the context where the command was executed.
		Bearer Termination	M	This information element indicates the Bearer Termination where the command was executed.

## 16.2.60 Inactivity timeout activation

This procedure is used to activate the inactivity timeout mechanism.

**Table 16.2.60/1: Procedures between (G)MSC server and MGW: Inactivity timeout activation**

Procedure	Initiated	Information element name	Information element required	Information element description
Inactivity timeout activation	(G)MSC-S	Context	M	This information element indicates the context for the command.
		Root Termination	M	This information element indicates that root termination is where the inactivity timeout mechanism is activated.
		Inactivity Timeout	M	Inactivity timeout event as defined in 3GPP TS 29.232 [6].
Inactivity timeout activation Ack	MGW	Context	M	This information element indicates the context where the command was executed.
		Root Termination	M	This information element indicates that root termination is where the command was executed.

## 16.2.61 Inactivity timeout indication

This procedure is used by MGW to report indication of inactivity timeout to MGC.

**Table 16.2.61/1: Procedures between (G)MSC server and MGW: Inactivity timeout indication**

Procedure	Initiated	Information element name	Information element required	Information element description
Inactivity timeout indication	MGW	Context	M	This information element indicates the context for the command.
		ROOT Termination	M	This information element indicates that root termination is where the inactivity timeout mechanism was activated.
		Inactivity Timeout	M	Inactivity timeout event as defined in 3GPP TS 29.232 [6].
Inactivity timeout indication Ack	(G)MSC-S	Context	M	This information element indicates the context where the command was executed.
		ROOT Termination	M	This information element indicates that root termination is where the command was executed.

## 16.2.62 Reserve RTP Connection Point

This procedure is used to reserve an RTP bearer termination.

Table 16.2.62.1: Reserve RTP Connection Point

Procedure	Initiated	Information element name	Information element required	Information element description
Reserve RTP Connection Point	(G)MSC-Server	Context/Context Request	M	This information element indicates the existing context or requests a new context for the bearer termination.
		Termination Request	M	This information element requests a new termination for the bearer to be established.
		IP Interface	O	This information element specifies the type of external interface to be used for the IP termination (e.g. AoIP).
		Local IP Resources	M	This information element indicates the resource(s) (e.g. codec, auxiliary payload types) for which the MGW shall be prepared to receive user data,
		ReserveValue	C	This information element indicates if multiple local resources are to be reserved. This information element shall be included if a speech codec and auxiliary payload types are required.
		Local Connection Address Request	M	This information element requests an IP address and port number on the MGW that the remote end can send user plane data to.
		Notify termination heartbeat	M	This information element requests termination heartbeat indications.
		Notify Released Bearer	O	This information element requests a notification of a released bearer.
		IP Realm Identifier	O	This information element indicates the IP realm of the IP termination.
		Cellular Text telephony modem	C	This information element indicates the need of CTM function. (NOTE 1)
		Number of desired listener context terminations	O	This information element indicates the number of desired terminations for a listener context in a VGCS or VBS call. It should be included in the first ADD request which establishes a Listener context. (NOTE 1)
		Circuit Switched Data	C	This information element indicates the PLMN bearer capabilities and when applicable GSM channel coding. This information element shall be included according to 3GPP TS 29.007 [37] and 3GPP TS 29.232 [6] for a non-speech / non SCUDIF multimedia call (see 3GPP TS 23.172 [20]) by the MSC server, or by the anchor-MSC in case of inter-MSC handover, for an anchor MGW network termination.
		IP Version	C	This information element indicates the version of the internet protocol to be applied at the termination for the user plane. This is required for IP address translation. (NOTE 4)
DiffServ Code Point	O	This information element indicates a specific DiffServ code point to be used in the IP header in packets sent on the IP termination. (NOTE 4)		

		DiffServ Tagging Behaviour	O	This information element indicates whether the Diffserv code point in the IP header in packets sent on the IP termination should be copied from the received value or set to a specific value. (NOTE 4)
		Remote Source Address Filtering	O	This information element indicates that remote source address filtering is required. (NOTE 4)
		Remote Source Address Mask	C	This information element provides information on the valid remote source addresses. This may be included if remote source address filtering is included. It shall not be included if remote source address filtering is not included. (NOTE 4)
		Remote Source Port Filtering	O	This information element indicates that remote source port filtering is required. (NOTE 4)
		Remote Source Port	C	This information element identifies the valid remote source port. This may be included if remote source port filtering is included. It shall not be included if remote source port filtering is not included. (NOTE 2, NOTE 4)
		Remote Source Port Range	C	This information element identifies a range of valid remote source ports. This may be included if remote source port filtering is included. It shall not be included if remote source port filtering is not included. (NOTE 2, NOTE 4)
		Media Inactivity Detection Required	O	This information element indicates that detection of inactive media flows is required. (NOTE 4)
		Inactivity Detection Time	C	This information element may be present if Inactive Media Detection is required and specifies the Inactivity Detection time. (NOTE 4)
		Inactivity Detection Direction	C	This information element may be present if Inactive Media Detection is required and specifies the Inactivity Detection direction. (NOTE 4)
		RTCP handling	O	Indicates whether or not the CS-MGW shall reserve a port for an RTCP flow. (NOTE 4)
		Traffic Policing Required	O	This information element indicates that policing of the media flow is required. (NOTE 4)
		Peak Data Rate	O	This information element may be present if Policing is required and specifies the permissible peak data rate for a media stream. (NOTE 3, NOTE 4)
		Sustainable Data Rate	O	This information element may be present if Policing is required and specifies the permissible sustainable data rate for a media stream. (NOTE 3, NOTE 4)
		Delay Variation Tolerance	O	This information element may be present if Policing on Peak Data Rate is required and specifies the maximum expected delay variation tolerance for the corresponding media stream. (NOTE 4)
		Maximum Burst Size	C	This information element shall be present if Policing on Sustainable Data Rate is required and specifies the maximum expected burst size for the corresponding media stream. (NOTE 4)

Reserve RTP Connection Point Ack	MGW	Context	M	This information element indicates the context where the command was executed.
		Termination	M	This information element indicates the termination where the command was executed.
		Local IP Resources	M	This information element indicates the resources that the MGW has reserved to receive the user plane data from the remote peer.
		Local Connection Address	M	This information element indicates the IP address and port on the MGW that shall receive user plane data from the remote peer.
NOTE 1: Only applies for Access side terminations				
NOTE 2: Remote Source Port and Remote Source Port Range are mutually exclusive.				
NOTE 3: At least one of these IEs shall be present when policing is required.				
NOTE 4: This information element is used for border control functions as defined in Annex A of 3GPP TS 29.235 [44]				

### 16.2.63 Configure RTP Connection Point

This procedure is used to configure or reconfigure an RTP bearer termination.

Table 16.2.63.1: Configure RTP Connection Point Procedure

Procedure	Initiated	Information element name	Information element required	Information element description
Configure RTP Connection Point	(G)MSC-Server	Context	M	This information element indicates the existing context.
		Termination	M	This information element indicates the existing bearer termination.
		IP Interface	O	This information element specifies the type of external interface to be used for the IP termination (e.g. AoIP).
		Local IP Resources	O	This information element indicates the resources (e.g. codec, auxiliary payload types) that the MGW may use on the reception of user plane data.
		Remote IP Resources	O	This information element indicates the resources (e.g. codec, auxiliary payload types) that the MGW may send user plane data to.
		Local Connection Address	O	This information element indicates the IP address and port on the MGW that the remote peer can send user plane data to.
		Remote Connection Address	O	This information element indicates the IP address and port that the MGW can send user plane data to.
		Reserve Value	C	This information element indicates if multiple resources are to be reserved. This information element shall be included if a speech codec and auxiliary payload types are required.
		Cellular Text telephony modem	C	This information element indicates the need of CTM function. (NOTE 1)
		Number of desired listener context terminations	O	This information element indicates the number of desired terminations for a listener context in a VGCS or VBS call. It should be included in the first ADD request which establishes a Listener context. (NOTE 1)
		Circuit Switched Data	O	This information element indicates the PLMN bearer capabilities and when applicable GSM channel coding. This information element shall be included according to 3GPP TS 29.007 [37] and 3GPP TS 29.232 [6] for a non-speech/non SCUDIF multimedia call by the MSC server, or by the anchor-MSC in case of inter-MSC handover for an anchor MGW network termination.
		DiffServ Code Point	O	This information element indicates a specific DiffServ code point to be used in the IP header in packets sent on the IP termination. (NOTE 4)
		DiffServ Tagging Behaviour	O	This information element indicates whether the Diffserv code point in the IP header in packets sent on the IP termination should be copied from the received value or set to a specific value. (NOTE 4)
		Remote Source Address Filtering	O	This information element indicates that remote source address filtering is required. (NOTE 4)

		Remote Source Address Mask	C	This information element provides information on the valid remote source addresses. This may be included if remote source address filtering is included. It shall not be included if remote source address filtering is not included. (NOTE 4)
		Remote Source Port Filtering	O	This information element indicates that remote source port filtering is required. (NOTE 4)
		Remote Source Port	C	This information element identifies the valid remote source port. This may be included if remote source port filtering is included. It shall not be included if remote source port filtering is not included. (NOTE 2, NOTE 4)
		Remote Source Port Range	C	This information element identifies a range of valid remote source ports. This may be included if remote source port filtering is included. It shall not be included if remote source port filtering is not included. (NOTE 2, NOTE 4)
		Media Inactivity Detection Required	O	This information element indicates that detection of inactive media flows is required. (NOTE 4)
		Inactivity Detection Time	C	This information element may be present if Inactive Media Detection is required and specifies the Inactivity Detection time. (NOTE 4)
		Inactivity Detection Direction	C	This information element may be present if Inactive Media Detection is required and specifies the Inactivity Detection direction. (NOTE 4)
		RTCP handling	O	Indicates whether or not the CS-MGW shall reserve a port for an RTCP flow. (NOTE 4)
		Traffic Policing Required	O	This information element indicates that policing of the media flow is required. (NOTE 4)
		Peak Data Rate	O	This information element may be present if Policing is required and specifies the permissible peak data rate for a media stream.(NOTE 3, NOTE 4)
		Sustainable Data Rate	O	This information element may be present if Policing is required and specifies the permissible sustainable data rate for a media stream.(NOTE 3, NOTE 4)
		Delay Variation Tolerance	O	This information element may be present if Policing on Peak Data Rate is required and specifies the maximum expected delay variation tolerance for the corresponding media stream. (NOTE 4)
		Maximum Burst Size	C	This information element shall be present if Policing on Sustainable Data Rate is required and specifies the maximum expected burst size for the corresponding media stream. (NOTE 4)
Configure RTP Connection Point Ack	MGW	Context	M	This information element indicates the context where the command was executed.
		Termination	M	This information element indicates the termination where the command was executed.
		Local IP Resource	O	This information element indicates the resources that the MGW has reserved to receive the user plane data from the far end.



		Remote IP Resource	C	This information element indicates the resource (i.e. codec) that the MGW shall use to send user data to. Shall be present if corresponding IE is present in the request.
		Local Connection Address	O	This information element indicates the IP address and port on the MGW that the remote end can send user plane data to.
		Remote Connection Address	C	This information element indicates the IP address and port that the MGW can send user plane data to. Shall be present if corresponding IE is present in the request.
NOTE 1: Only applies for Access side terminations				
NOTE 2: Remote Source Port and Remote Source Port Range are mutually exclusive.				
NOTE 3: At least one of these IEs shall be present when policing is required.				
NOTE 4: This information element is used for border control functions as defined in Annex A of 3GPP TS 29.235 [44]				

## 16.2.64 Reserve and Configure RTP Connection Point

This procedure is used to reserve and configure multimedia-processing resources for an RTP termination.

**Table 16.2.64.1: Reserve and Configure RTP Connection Point**

Procedure	Initiated	Information element name	Information element required	Information element description
Reserve and Configure RTP Connection Point	(G)MSC-Server	Context/Context Request	M	This information element indicates the existing context or requests a new context for the bearer termination.
		Termination/Termination Request	M	This information element indicates the existing bearer termination or requests a new termination for the bearer to be established.
		IP Interface	O	This information element specifies the used interface type for the IP termination (e.g. NboIP).
		Local IP Resources	M	This information element indicates the resource(s) (e.g. codec, auxiliary payload types) for which the MGW shall be prepared to receive user data,
		Remote IP Resources	M	This information element indicates the resources (e.g. codec, auxiliary payload types) that the MGW shall use to send user data.
		Reserve Value	C	This information element indicates if multiple IP resources are to be reserved. This information element shall be included if a speech codec and auxiliary payload types are required.
		Cellular Text telephony modem	C	This information element indicates the need of CTM function. (NOTE 1)
		Local Connection Address Request	M	This information element requests an IP address and port number on the MGW that the remote end can send user plane data to.

	Remote Connection Address	M	This information element indicates the IP address and ports of the remote party that the MGW can send user plane data to.
	Notify termination heartbeat	M	This information element requests termination heartbeat indications.
	Notify Released Bearer	O	This information element requests a notification of a released bearer.
	IP Realm Identifier	O	This information element indicates the IP realm of the IP termination.
	Circuit Switched Data	O	This information element indicates the PLMN bearer capabilities and when applicable GSM channel coding. This information element shall be included according to 3GPP TS 29.007 [6] and 3GPP TS 29.232 [8] for a non-speech / non SCUDIF multimedia call (see 3GPP TS 23.172 [20]) by the MSC server, or by the anchor-MSC in case of inter-MSC handover, for an anchor MGW network termination.
	IP Version	C	This information element indicates the version of the internet protocol to be applied at the termination for the user plane. This is required for IP address translation. (NOTE 4)
	DiffServ Code Point	O	This information element indicates a specific DiffServ code point to be used in the IP header in packets sent on the IP termination. (NOTE 4)
	DiffServ Tagging Behaviour	O	This information element indicates whether the Diffserv code point in the IP header in packets sent on the IP termination should be copied from the received value or set to a specific value. (NOTE 4)
	Remote Source Address Filtering	O	This information element indicates that remote source address filtering is required. (NOTE 4)
	Remote Source Address Mask	C	This information element provides information on the valid remote source addresses. This may be included if remote source address filtering is included. It shall not be included if remote source address filtering is not included. (NOTE 4)
	Remote Source Port Filtering	O	This information element indicates that remote source port filtering is required. (NOTE 4)
	Remote Source Port	C	This information element identifies the valid remote source port. This may be included if remote source port filtering is included. It shall not be included if remote source port filtering is not included. (NOTE 2, NOTE 4)
	Remote Source Port Range	C	This information element identifies a range of valid remote source ports. This may be included if remote source port filtering is included. It shall not be included if remote source port filtering is not included. (NOTE 2, NOTE 4)
	Media Inactivity Detection Required	O	This information element indicates that detection of inactive media flows is required. (NOTE 4)
	Inactivity Detection Time	C	This information element may be present if Inactive Media Detection is required and specifies the Inactivity Detection time. (NOTE 4)
	Inactivity Detection Direction	C	This information element may be present if Inactive Media Detection is required and specifies the Inactivity Detection direction. (NOTE 4)

		RTCP handling	O	Indicates whether or not the CS-MGW shall reserve a port for an RTCP flow. (NOTE 4)
		Traffic Policing Required	O	This information element indicates that policing of the media flow is required. (NOTE 4)
		Peak Data Rate	O	This information element may be present if Policing is required and specifies the permissible peak data rate for a media stream.(NOTE 3, NOTE 4)
		Sustainable Data Rate	O	This information element may be present if Policing is required and specifies the permissible sustainable data rate for a media stream.(NOTE 3, NOTE 4)
		Delay Variation Tolerance	O	This information element may be present if Policing on Peak Data Rate is required and specifies the maximum expected delay variation tolerance for the corresponding media stream. (NOTE 4)
		Maximum Burst Size	C	This information element shall be present if Policing on Sustainable Data Rate is required and specifies the maximum expected burst size for the corresponding media stream. (NOTE 4)
Reserve and Configure RTP Connection Point	MGW	Context	M	This information element indicates the context where the command was executed.
		Termination	M	This information element indicates the termination where the command was executed.
		Local IP Resources	M	This information element indicates the resources that the MGW has reserved to receive the user plane data from the remote side.
		Remote IP Resources	M	This information element indicates the resource (i.e. codec) that the MGW shall use to send user data.
		Local Connection Addresses	M	This information element indicates the IP address and port on the MGW that shall receive user plane data.
NOTE 1: Only applies for Access side terminations				
NOTE 2: Remote Source Port and Remote Source Port Range are mutually exclusive.				
NOTE 3: At least one of these IEs shall be present when policing is required.				
NOTE 4: This information element is used for border control functions as defined in Annex A of 3GPP TS 29.235 [44]				

## 16.2.65 Realm Availability Change - Activation

This procedure is used to activate the realm availability notification mechanism.

**Table 16.2.65.1: Realm Availability Change - Activation**

Procedure	Initiated	Information element name	Information element required	Information element description
Realm Availability Change – Activate	(G)MSC-Server	Context	M	This information element indicates the NULL context.
		Root Termination	M	This information element indicates that root termination is where the realm availability change notification mechanism is activated.
		Realm Availability Change Activate	M	This information element requests to activate the realm availability change notification mechanism.
Realm Availability Change -Activate Ack	MGW	Context	M	This information element indicates the NULL context.
		Root Termination	M	This information element indicates that root termination is where the command was executed.

NOTE: This procedure is used for border control functions as defined in Annex A of 3GPP TS 29.235 [44]

## 16.2.66 Realm Availability Change - Indication

This procedure is used to inform the (G)MSC-Server that there has been a change to the list of currently available realms.

**Table 16.2.66.1: Realm Availability Change - Indication**

Procedure	Initiated	Information element name	Information element required	Information element description
Realm Availability Change - Indication	MGW	Context	M	This information element indicates the NULL context.
		Root Termination	M	This information element indicates that root termination is where the realm availability change notification mechanism was activated.
		Changes to Realm Availability	M	This information element indicates the changes to the list of available realms.
Realm Availability Change - Indication Ack	(G)MSC-Server	Context	M	This information element indicates the NULL context.
		Root Termination	M	This information element indicates that root termination is where the command was executed.

NOTE: This procedure is used for border control functions as defined in Annex A of 3GPP TS 29.235 [44]

## 16.2.67 Media Inactivity Notification

This procedure is used to notify the (G)MSC-Server of media inactivity on the MGW.

**Table 16.2.67.1: Media Inactivity Notification**

Procedure	Initiated	Information element name	Information element required	Information element description
Media Inactivity Notification	MGW	Context	M	This information element indicates the context for the bearer termination.
		Bearer Termination	M	This information element indicates the bearer termination where the media inactivity detection was activated.
		Media Inactivity	M	This information element notifies the (G)MSC-Server of Media inactivity detection on the bearer termination.
Media Inactivity Notification Ack	(G)MSC-Server	Context	M	This information element indicates the context where the command was executed.
		Bearer Termination	M	This information element indicates the bearer termination where the command was executed.

NOTE: This procedure is used for border control functions as defined in Annex A of 3GPP TS 29.235 [44]

## 17 Bearer Redirect

The BICC [22] Bearer Redirect mechanism may be used for optimising the bearer path when an endpoint of a call changes due to the operation of an application layer service.

### 17.1 Example of use of Bearer Redirect with Call Forwarding on No Reply (CFNRy)

Before CFNRy:

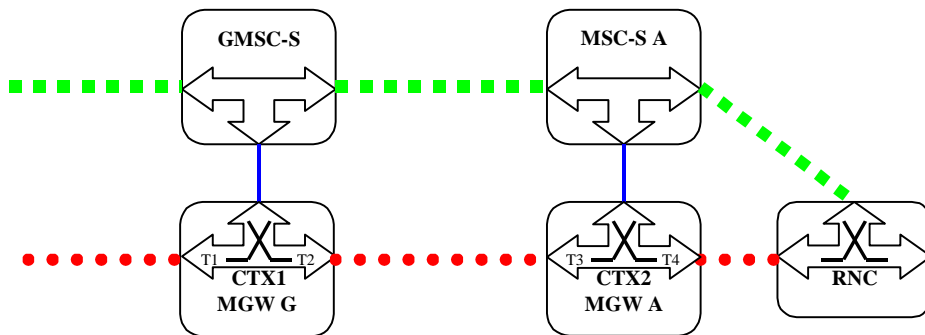


Figure 17.1A: Before CFNRy (Network model)

After CFNRy and Bearer Redirection:

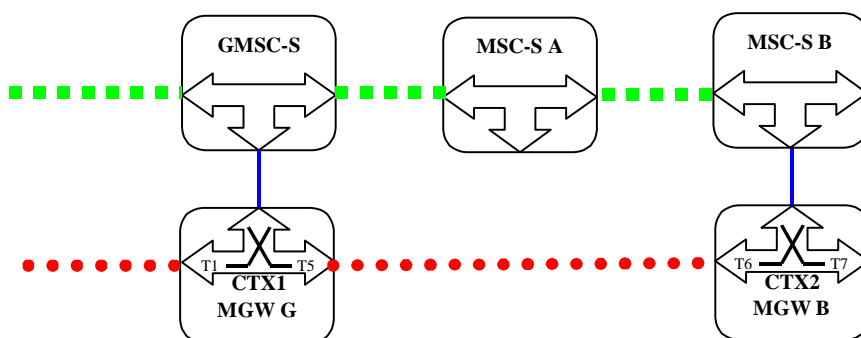


Figure 17.1B: CFNRy and Bearer Redirect (Network model)

Figure 17.2 shows the message sequence example for the call forwarding on no reply with Bearer Redirect. In the example, after the call and the bearer towards the access have been released MSC server A requests the MGW A to remove the bearer termination for the served mobile subscriber. MSC server A requests the GMSC server to redirect the bearer to the forwarded to subscriber (interactions towards the access are not shown), using MSC server A as a call control anchor. Once the bearer towards MGW B is established the GMSC server instructs MGW G to connect the incoming bearer to the new bearer (towards MGW B) and informs MSC server A. Once informed that the new bearer has been established MSC server A instructs the GMSC server to removes the old bearer termination (towards MGW A).

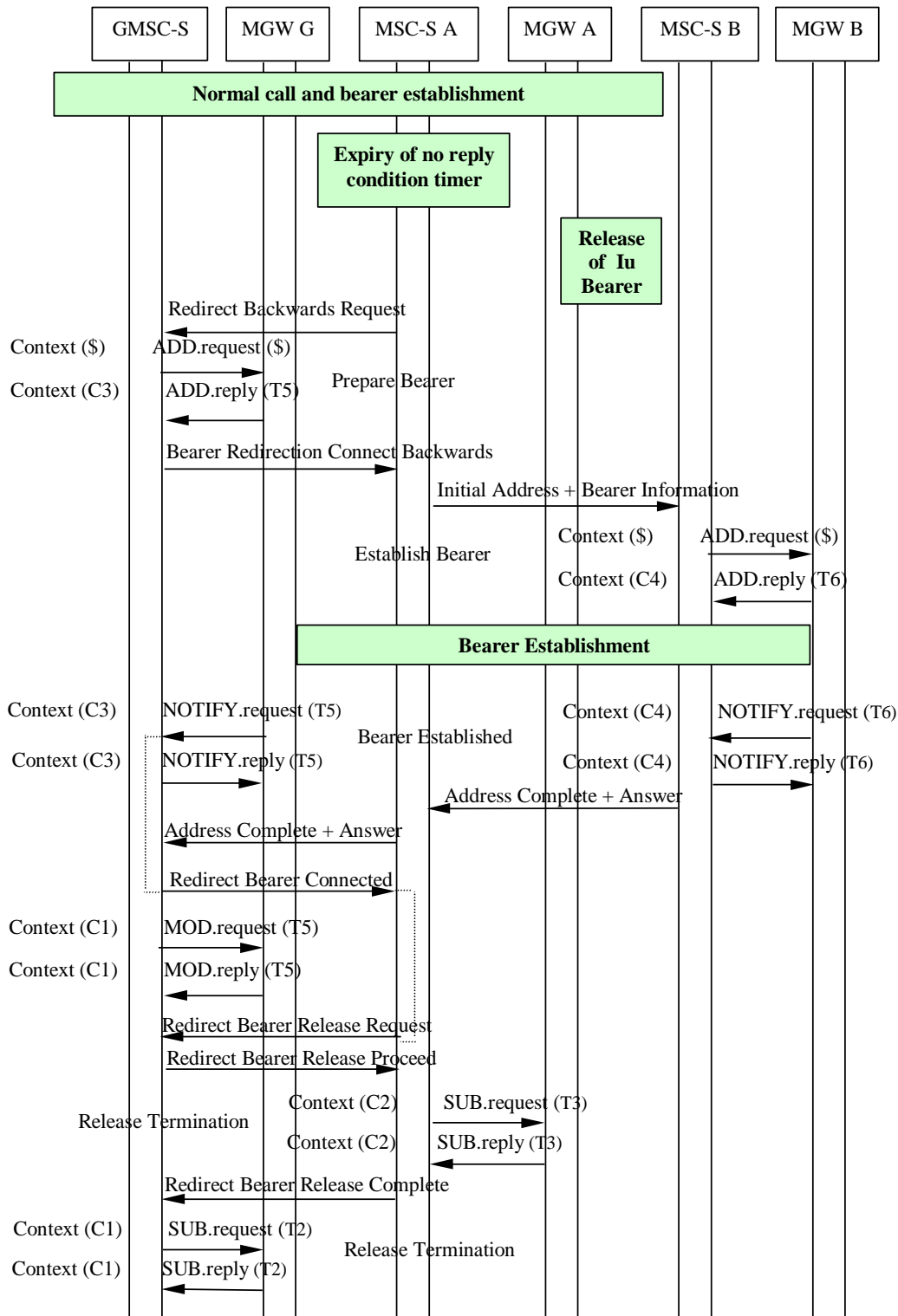


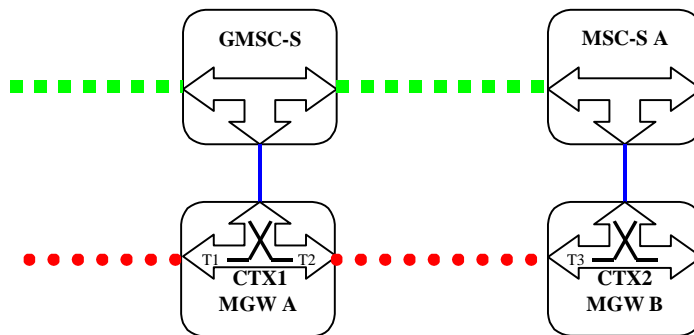
Figure 17.2: Information flow for CFNRy with Bearer Redirect (message sequence chart)

# 18 (G)MSC MGW Tandeming

In all call flow examples a (G)MSC server may tandem (either during call setup or during an active call, as part of an application layer service invocation) the bearer through one or more MGWs under its control, in order to access bearer resources which may be distributed over a number of specialised MGWs.

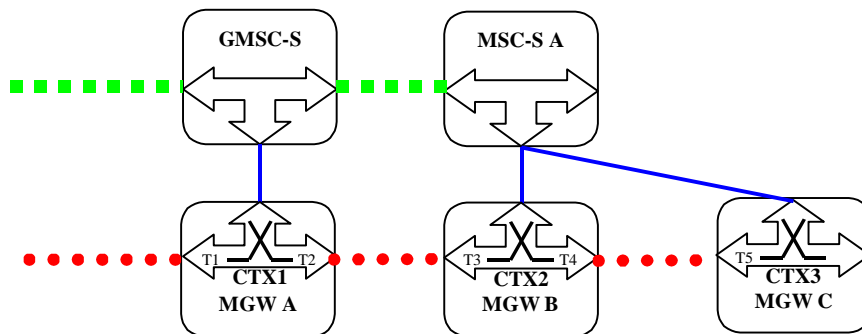
## 18.1 Example of use of MSC MGW Tandeming during call setup to provide bearer access to specialised MGW resources

Before MGW tandeming:



**Figure 18.1A: MSC before MGW Tandeming during call setup to provide bearer access to specialised MGW resources (Network model)**

After MGW tandeming:



**Figure 18.1B: MSC after MGW Tandeming during call setup to provide bearer access to specialised MGW resources (Network model)**

The figure 18.2 below shows the message sequence example for MSC MGW Tandeming during call setup to provide bearer access to specialised MGW resources. In the example, after the signalling towards MSC server A and the bearer towards the MGW B is established, MSC server A requests the MGW B to tandem the bearer and terminate it at MGW C, where specialised bearer resources which are not available at MGW B may be provided.

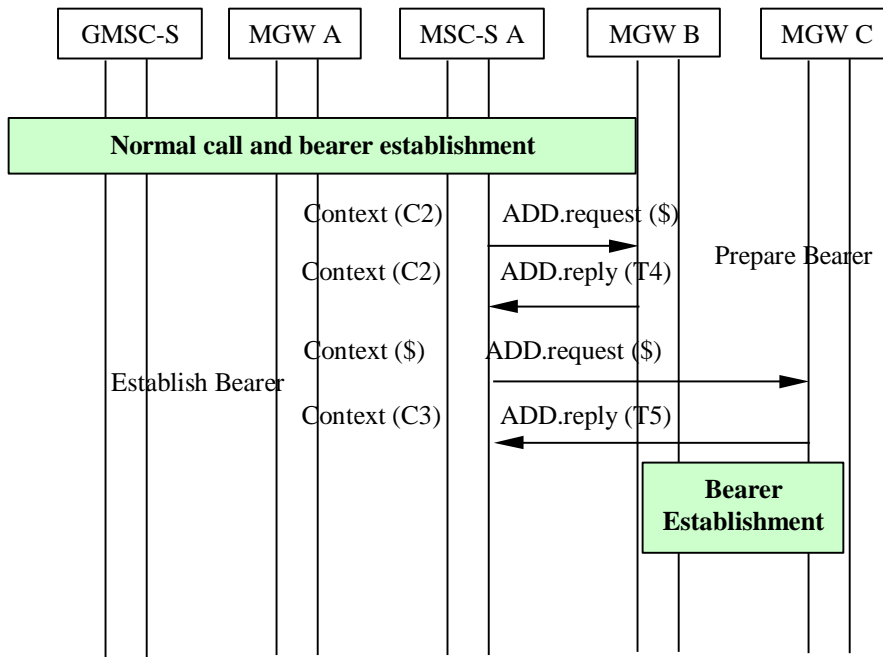


Figure 18.2: MSC MGW Tandeming during call setup to provide bearer access to specialised MGW resources (message sequence chart)

## 19 Timers for bearer independent CS core network

Table 19.1: Timers for bearer independent CS core network

Timer identity	Timer value	Timer started	Timer stopped	Timer expiry
Start_Bearer_Establishment	1 – 14 seconds	Paging procedure is started. Applied only if network side bearer establishment is delayed until paging procedure is completed.	Paging procedure is completed or optionally when Call Confirmed message is received.	The network side bearer establishment is started.

## 20 Multiple IP Realms

Figure 20/1 shows a scenario to support multiple IP realms when the Iu interface or Nb interface supports IP bearer.

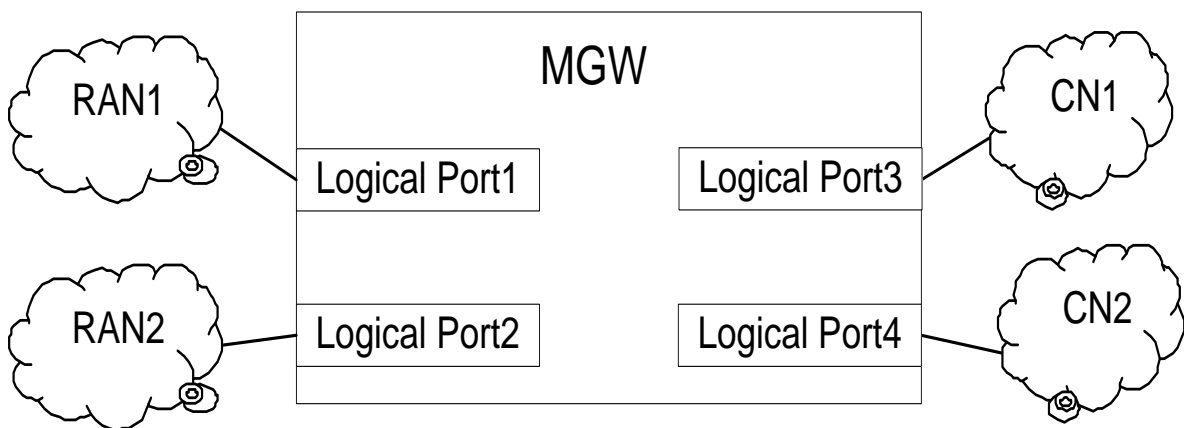


Figure 20/1 Multiple IP realms scenario for Iu or Nb interface



The RAN1, RAN2, CN1 and CN2 represents separate IP realm. The definition of IP realm is specified in IETF RFC 2663 [41].

The Logical Port 1/2/3/4 represents a logical port connected with the IP realm in the MGW.

For establishing session when multiple IP realms are used in the MGW, the MGC may indicate the IP realm identifier to the MGW. The MGW shall assign the IP termination in the IP realm indicated.

A default IP realm may be configured such that if the MGW has not received the IP realm identifier and the MGW supports multiple IP realms then the default IP realm shall be used.

If the MGW does not support the option to indicate an IP realm then it is free to select an IP port as per implementation permitted in previous releases.

## Annex A (informative): Change History

Change history							
Date	TSG #	TSG Doc.	CR	R e v	Subject/Comment	Old	New
Jul 2000					Initial draft	0.0.1	0.0.2
Aug 2000					Comments from TSG-CN WG4#3 incorporated and draft further elaborated	0.0.2	0.1.0
Sep 2000					Contributions and comments from TSG-CN WG4#4 incorporated and draft further elaborated	0.1.0	0.2.0
Oct 2000					Contributions and comments from TSG-CN WG4 Ad Hoc incorporated and draft further elaborated	0.2.0	1.0.1
Nov 2000	CN#10				For information to TSG-CN #10	1.0.1	1.1.0
Jan 2001					Contributions and comments from TSG-CN WG4 #6 incorporated and draft further elaborated.	1.1.0	1.1.1
Feb 2001					New clause structure for handover, editorial corrections.	1.1.1	1.2.0
Feb 2001					Contributions and comments from TSG-CN WG4 Ad Hoc incorporated.	1.2.0	2.0.0
Mar 2001	CN#11	NP-010081			Contributions and comments from TSG-CN WG4 #7 incorporated. Approved in CN#11	2.0.0	4.0.0
Jun 2001	CN#12	N4-010676	002	1	Voice Processing Function Alignment/Clean Up for Call Handover and Relocation	4.0.0	4.1.0
Jun 2001	CN#12	N4-010678	004	1	Corrections to Call Clearing	4.0.0	4.1.0
Jun 2001	CN#12	N4-010680	006	1	Alignment of procedure names to TS 29.232 and editorial changes	4.0.0	4.1.0
Sep 2001	CN#13	NP-010452	008	1	Slight Misalignment of Continuity Message Handling	4.1.0	4.2.0
Sep 2001	CN#13	NP-010452	009		Updates to Clause 9.1	4.1.0	4.2.0
Sep 2001	CN#13				Editorial clean up	4.1.0	4.2.0
Dec 2001	CN#14	NP-010619	012		Correction of Handover/Relocation for Speech and Non-speech calls	4.2.0	4.3.0
Dec 2001	CN#14	NP-010619	014	2	New timer to support long paging in bearer independent network	4.2.0	4.3.0
Dec 2001	CN#14	NP-010619	016	1	Correction for Release of Network Bearer	4.2.0	4.3.0
Dec 2001	CN#14	NP-010631	011		Introduction of MGW Congestion Handling	4.3.0	5.0.0
Dec 2001	CN#14	NP-010631	013	1	Maintenance locking of MG	4.3.0	5.0.0
Mar 2002	CN#15	NP-020029	021		(G)MSC restoration	5.0.0	5.1.0
Mar 2002	CN#15	NP-020029	023	2	Correction of Bearer Modification Handling	5.0.0	5.1.0
Jun 2002	CN#16	NP-020260	024		MSC server GTT enhancement	5.1.0	5.2.0
Jun 2002	CN#16	NP-020260	025	1	Alignment of terminology regarding GERAN access	5.1.0	5.2.0
Jun 2002	CN#16	NP-020248	028		Correction of an incorrect reference in Section 8.3.3.2	5.1.0	5.2.0
Sep 2002	CN#17	NP-020458	026	4	Introduction of GERAN lu-mode	5.2.0	5.3.0
Sep 2002	CN#17	NP-020459	029	1	Misalignment between TS 23205 and TS 29232 for Global Text Telephony	5.2.0	5.3.0
Sep 2002	CN#17	NP-020459	030	1	Misalignment between TS 23.226 and TS 23.205 for Global Text Telephony.	5.2.0	5.3.0
Sep 2002	CN#17	NP-020463	033	1	Correction on wrong message handling for subsequent Handover	5.2.0	5.3.0

Dec 2002	CN#18	NP-020597	031	3	lu-cs over IP related corrections for 23.205	5.3.0	5.4.0
Dec 2002	CN#18	NP-020596	035	2	CAMEL4 Call Party Handling interworking with Bearer independent CS core	5.3.0	5.4.0
Dec 2002	CN#18	NP-020596	036	1	Clarification of the termination of the lu interface components in the Bearer Independent Architecture	5.3.0	5.4.0
Mar 2003	CN#19	NP-030108	039	1	Bearer Release for lu CS on IP	5.4.0	5.5.0
Jun 2003	CN#20	NP-030212	042		Clarification of handling of DTMF	5.5.0	5.6.0
Jun 2003	CN#20	NP-030212	044	1	Clarification of handling of DTMF timing	5.5.0	5.6.0
Mar 2003	CN#23	NP-040052	050	1	Use Modify command for change of flow direction to bothway	5.6.0	5.7.0
Dec 2004	CN#26				Release 6 after CN#26	5.7.0	6.0.0
Mar 2005	CN#27	NP-050057	045	7	Addition of the trace package	6.0.0	6.1.0
Mar 2005	CN#27	NP-050034	052	2	Stage 2 Procedure for Emergency Call Indication	6.0.0	6.1.0
Mar 2005	CN#27	NP-050028	056		Solving contradiction for Release Cause in Release Bearer Procedure between stage 2 and stage 3	6.0.0	6.1.0
Jun 2005	CT#28	CP-050101	065		Multi-Party Conference call Implementation	6.1.0	6.2.0
Sep 2005	CT#29	CP-050289	059	2	Introducing the ServiceChangeProfile also to the relevant stage 2 procedures	6.2.0	6.3.0
Sep 2005	CT#29	CP-050289	061	2	MGW Recovery clarification	6.2.0	6.3.0
Sep 2005	CT#29	CP-050308	068	1	Alignment of Stage 2 with Continuity test Procedure	6.2.0	6.3.0
Sep 2005	CT#29	CP-050277	071		Introduction of chapter to describe CMM message for GSM fax	6.2.0	6.3.0
Sep 2005	CT#29	CP-050289	073	1	Notifications for IP Bearer Establishment	6.2.0	6.3.0
Sep 2005	CT#29	CP-050308	082		Minor correction in references	6.2.0	6.3.0
Sep 2005	CT#29	CP-050308	083	1	Transparent data call request in dual mode case	6.2.0	6.3.0
Dec 2005	CT#30	CP-050608	0095		Correction of Notify establish bearer information element	6.3.0	6.4.0
Dec 2005	CT#30	CP-050603	0098		Missing stage 2 definition for Bearer Modified and Bearer Modification Failed procedures	6.3.0	6.4.0
Dec 2005	CT#30	CP-050603	0102		Correction of term Bearer Termination in procedures that concern the whole MGW	6.3.0	6.4.0
Dec 2005	CT#30	CP-050603	0104		Adding missing termination ID to Acknowledgement part of notification procedures	6.3.0	6.4.0
Dec 2005	CT#30	CP-050608	0107		Removing Notify Bearer Modification Information element from Prepare IP transport procedure	6.3.0	6.4.0
Dec 2005	CT#30	CP-050607	0108	1	Bearer Released Event to Reserve Circuit procedure stage 2	6.3.0	6.4.0
Dec 2005	CT#30	CP-050629	0089	2	Clean-up of hanging contexts and terminations	6.4.0	7.0.0
Dec 2005	CT#30	CP-050629	0092	1	Corrections for Delayed Backward Bearer Establishment with IP Transport	6.4.0	7.0.0
Dec 2005	CT#30	CP-050618	0110	2	Correct the UP initialization error in Figure 6.6/1	6.4.0	7.0.0
Mar 2006	CT#31	CP-060064	0117	3	Correction To Termination State Handling	7.0.0	7.1.0
Mar 2006	CT#31	CP-060078	0120	2	Clarification of periodic sending of Audits to recognize MGW unavailable	7.0.0	7.1.0
Mar 2006	CT#31	CP-060064	0123	1	Miscellaneous corrections to messages/procedures	7.0.0	7.1.0
Mar 2006	CT#31	CP-060078	0126	1	Internal bearer for multiparty service	7.0.0	7.1.0
Mar 2006	CT#31	CP-060078	0127	1	Wrong implementation of CP-050629 / C4-051767 (CR#089rev2)	7.0.0	7.1.0
Mar 2006	CT#31	CP-060078	0128		ServiceChangeVersion in MGW Re-Register procedure	7.0.0	7.1.0
Mar 2006	CT#31	CP-060078	0132		Correct the termination error in figure 13.19	7.0.0	7.1.0
Mar 2006	CT#31	CP-060064	0135	1	Removal Of stream mode modification at bearer release	7.0.0	7.1.0
Mar 2006	CT#31	CP-060064	0141		Replacing Notify Bearer Modification information element with Notify Bearer Event in Prepare_IP_Transport procedure.	7.0.0	7.1.0
Jun 2006	CT#32	CP-060301	0150	1	Multimedia & CSD calls	7.1.0	7.2.0
Jun 2006	CT#32	CP-060315	0153	1	Solving contradiction between tunnel option in 23.205 and 29.232	7.1.0	7.2.0
Dec 2006	CT#34	CP-060554	0165		Amend the call flow of handover procedure	7.2.0	7.3.0
		CP-060569	0159	5	Enhancements for VGCS/VBS in SPLIT architecture		
		CP-060569	0167	1	Example of in-band information sending with the topology descriptor		
Mar 2007	CT#35	CP-070014	0172	3	IP domain connection indication	7.3.0	7.4.0
			0173	1	Clarify message sequence of VGCS call		
Jun 2007	CT#36	CP-070322	0177		ServiceChangeMGCIid parameter	7.4.0	7.5.0
Sep 2007	CT#37	CP-070521	0180	3	Correction To Call Hold	7.5.0	7.6.0

	CP-070530	0185	2	Establish internal Nb connections via IPBCP in MPTY		
	CP-070530	0190	3	Support inactivity timer (H.248.14) for MGWs detecting the failure of MGC		
Sep 2007	CT#37 CP-070569	0191	2	Mandatory use termination heartbeat (H.248.36) when establish bearer/prepare bearer	7.6.0	8.0.0
Dec 2007	CT#38 CP-070749	0196	1	Number of needed listener context terminations to ASCII package	8.0.0	8.1.0
		0192	1	Clarifications to Send Tone / Play Announcement procedures		
Mar 2008	CT#39 CP-080011	0200		Detect DTMF event after reporting of DTMF	8.1.0	8.2.0
	CP-080025	0204	1	Private communication during a Multiparty call		
Jun 2008	CT#40 CP-080271	0207	3	Clarification of several inconsistencies in procedure	8.2.0	8.3.0
		0208	1	Clarification of subscribers' roles in CW procedure		
		0211	1	Protocol negotiation result procedures between MSC Server and MGW		
		0209	3	Support for A interface user plane over IP		
		0210	2	Revision of scope of TS 23.205		
Sep 2008	CT#41 CP-080466	0213	1	Handover Scenarios for AoIP	8.3.0	8.4.0
		0215		Call Clearing for A Interface on IP		
		0216	1	IP interface type indicator		
		0217		Use of Global Text Telephony with A over IP		
		0218	1	Combining certain procedures with 'Reserve RTP Connection Point'		
Dec 2008	CT#42 CP-080705	0220	1	Corrections to Call Forwarding procedures	8.4.0	8.5.0
	CP-080710	0222	1	Enhanced SRNS relocation		
	CP-080697	0224	2	BSS Internal Handover procedure		
	CP-080697	0225		AoIP impacts on subclause 'Interworking with GERAN A interface'		
	CP-080695	0226	4	Signalling of CAT Capability		
	CP-080697	0228	2	Impact on Handover/Relocation and Interactions with Other Services for AoIP		
Jun 2009	CT#44 CP-090312	0231	2	Customized alerting tone indicators	8.5.0	8.6.0
	CP-090309	0232		BSS Internal Handover procedure		
				Correct previous entry in history table	8.6.0	8.6.1
Sep 2009	CT#45 CP-090541	0234		Clarification of Use of Reserve and Configure RTP Connection Point	8.6.1	8.7.0
	CP-090541	0235		IWF Rate Change Procedure with AoIP		
	CP-090541	0236		Removal of Editor's Notes for IP Interface Type		
2009-12	-	-	-	Update to Rel-9 version (MCC)	8.7.0	9.0.0
2010-09	CT#49 CP-100450	0239	-	Terminating Access Bearer Assignment	9.0.0	9.1.0
2011-03	CT#51 CP-110046	0243	-	BSS Internal Handover	9.1.0	9.2.0
		0240	1	Adding CS-lx functionalities to Mc-profile		
2011-03	CT#51 CP-110254	0241	2	Introduction of LCLS	9.2.0	10.0.0
2011-06	CT#52 CP-110352	0247	1	Adding Local Connection Address request to Reserve and Configure RTP Connection point	10.0.0	10.1.0
2011-09	CT#53 CP-110563	0249		Media inactivity notification procedure	10.1.0	10.2.0
2011-09	CT#53 CP-110585	0250	2	Addition of Anonymous Call Rejection in the CS layered architecture	10.2.0	11.0.0