

3GPP TS 23.146 V11.0.0 (2012-09)

Technical Specification

3rd Generation Partnership Project; Technical Specification Group Core Network and Terminals; Technical realization of facsimile group 3 non-transparent (Release 11)



The present document has been developed within the 3rd Generation Partnership Project (3GPPTM) and may be further elaborated for the purposes of 3GPP.

The present document has not been subject to any approval process by the 3GPP Organisational Partners and shall not be implemented. This Specification is provided for future development work within 3GPP only. The Organisational Partners accept no liability for any use of this Specification. Specifications and reports for implementation of the 3GPPTM system should be obtained via the 3GPP Organisational Partners' Publications Offices.

Keywords

LTE, UMTS, fax

3GPP

Postal address

3GPP support office address

650 Route des Lucioles - Sophia Antipolis
Valbonne - FRANCE
Tel.: +33 4 92 94 42 00 Fax: +33 4 93 65 47 16

Internet

<http://www.3gpp.org>

Copyright Notification

No part may be reproduced except as authorized by written permission.
The copyright and the foregoing restriction extend to reproduction in all media.

© 2012, 3GPP Organizational Partners (ARIB, ATIS, CCSA, ETSI, TTA, TTC).
All rights reserved.

UMTS™ is a Trade Mark of ETSI registered for the benefit of its members
3GPP™ is a Trade Mark of ETSI registered for the benefit of its Members and of the 3GPP Organizational Partners
LTE™ is a Trade Mark of ETSI currently being registered for the benefit of its Members and of the 3GPP Organizational Partners
GSM® and the GSM logo are registered and owned by the GSM Association

Contents

Foreword	5
1 Scope	6
2 References.....	6
3 Definition and abbreviations	7
3.1 Definitions	7
3.2 Abbreviations.....	7
4 Network architecture	8
4.1 Service definition.....	8
4.2 Network architecture.....	9
5 Reference configuration at the mobile station	9
5.1 FA functionality	10
5.2 UMTS facsimile machine functionality.....	10
6 Connection types.....	10
6.1 Protocol model.....	11
6.2 Mobile to mobile calls	12
6.3 Procedure interrupts	12
6.4 Radio channel modification	12
7 Facsimile adaptor	12
7.1 Principles of the Facsimile Protocol Adaptation.....	12
7.2 FA functionality	13
7.2.1 Packet elements between FAs.....	14
7.2.2 Interactions between and interventions within the FAs	15
7.2.3 BCS phase	16
7.2.3.1 BCS command/response procedures	16
7.2.3.2 Compatibility checking	17
7.2.3.3 Training Check	17
7.2.3.4 Control of transmission rate.....	18
7.2.4 Message phase.....	18
7.2.4.1 Message Transcoding.....	18
7.2.4.2 Generation of the normal data packet.....	19
7.2.4.3 Generation of the error correction data packet	19
7.2.4.4 Normal facsimile data	19
7.2.4.5 Error correction facsimile data	19
7.2.4.6 Controlling of facsimile coded data.....	20
7.2.4.6.1 Transmitting Fax Adapter	20
7.2.4.6.2 Receiving Fax Adapter	20
7.2.5 Disconnect procedure	21
7.2.6 Timeouts	21
8 Use of terminal adaptation functions.....	21
8.1 Principles of terminal adaptation functions.....	21
8.2 Specific TAFs for facsimile service	22
9 Signalling aspects.....	22
9.1 Handling of tonal signals	22
9.2 Call establishment	22
9.2.1 Mobile terminated call.....	22
9.2.1.1 Speech then facsimile	23
9.2.1.2 Auto answer.....	23
9.2.2 Mobile originated calls	23
9.2.2.1 Speech then facsimile	23
9.2.2.2 Auto calling.....	24
9.2.2.3 Manual calling	24

10	Interworking to fixed networks	25
10.1	Interworking to PSTN.....	25
10.2	Interworking to ISDN.....	25
Annex A (normative):	Structure and contents of the FA protocol elements.....	26
A.1	Internet Fax Protocol.....	26
A.2	Facsimile UDP Transport Layer Protocol.....	26
A.3	User Datagram Protocol	26
A.4	Internet Protocol	27
A.5	Point to Point Protocol.....	27
A.6	Mapping of FA frames	27
Annex B (informative):	Abbreviations from ITU-T Recommendation T.30 and T.4	28
Annex C (informative):	Procedure examples.....	29
Annex D (normative):	SDL Diagrams	41
Annex E (normative):	ASN.1 notation.....	79
Annex F (informative):	Change history.....	80

Foreword

This Technical Specification has been produced by the 3rd Generation Partnership Project (3GPP).

The present document defines the technical realization of facsimile group 3 using non-transparent network support within the 3GPP system.

The contents of the present document are subject to continuing work within the TSG and may change following formal TSG approval. Should the TSG modify the contents of the present document, it will be re-released by the TSG with an identifying change of release date and an increase in version number as follows:

Version x.y.z

where:

- x the first digit:
 - 1 presented to TSG for information;
 - 2 presented to TSG for approval;
 - 3 or greater indicates TSG approved document under change control.
- y the second digit is incremented for all changes of substance, i.e. technical enhancements, corrections, updates, etc.
- z the third digit is incremented when editorial only changes have been incorporated in the document.

1 Scope

The present document describes the procedures allowing the technical realization of the real time end-to-end facsimile group 3 service within the UMTS PLMN using non-transparent network support according to the definition of the Teleservices 61 and 62 specified in 3GPP TS 22.003. Within the present document particular attention is given to Teleservice "Alternate speech/facsimile group 3" (Teleservice 61). However, the definitions apply also to Teleservice "Automatic facsimile group 3" (Teleservice 62) with the exception of all actions concerned with the speech phase. Consequently, in the following descriptions the term "Teleservice" denotes both Teleservice 61 and Teleservice 62 as appropriate.

NOTE: V.25bis is outdated. References to V.25bis procedures need to be replaced by corresponding procedures based on V.250 and 3GPP TS 27.007.

2 References

The following documents contain provisions which, through reference in this text, constitute provisions of the present document.

- References are either specific (identified by date of publication, edition number, version number, etc.) or non-specific.
- For a specific reference, subsequent revisions do not apply.
- For a non-specific reference, the latest version applies.

- [1] 3GPP TS 22.003: "Circuit Teleservices supported by a Public Land Mobile Network (PLMN)".
- [2] 3GPP TR 23.910: "Circuit Switch Data Bearer Services".
- [3] 3GPP TS 24.008: "Mobile radio interface layer 3 specification".
- [4] 3GPP TS 27.001: "General on Terminal Adaptation Functions (TAF) for Mobile Stations (MS)".
- [5] 3GPP TS 27.002: "Terminal Adaptation Functions (TAF) for services using asynchronous bearer capabilities".
- [6] 3GPP TS 27.007: "AT command set for 3GPP User Equipment(UE)".
- [7] 3GPP TS 29.007: "3GPP; TSG CN; General requirements on interworking between the Public Land Mobile Network (PLMN) and the Integrated Services Digital Network (ISDN) or Public Switched Telephone Network (PSTN)".
- [8] ITU-T Recommendation T.4: "Standardization of group 3 facsimile apparatus for document transmission".
- [9] ITU-T Recommendation T.30: "Procedures for document facsimile transmission in the general switched telephone network".
- [10] ITU-T Recommendation V.21: "300 bits per second duplex modem standardized for use in the general switched telephone network".
- [11] ITU-T Recommendation V.24: "List of definitions for interchange circuits between data terminal equipment (DTE) and data circuit-terminating equipment (DCE)".
- [12] ITU-T Recommendation V.27 ter: "4 800/2 400 bits per second modem standardized for use in the general switched telephone network".
- [13] ITU-T Recommendation V.29: "9 600 bits per second modem standardized for use on point-to-point 4-wire leased telephone-type circuits".
- [14] ITU-T Recommendation V.17: "A 2-wire modem for facsimile applications with rates up to 14 400 bit/s".

- [15] ITU-T Recommendation V.250: "Serial asynchronous automatic dialling and control".
- [16] ITU-T Recommendation X.300: "General principles and arrangements for interworking between public data networks, and between public data networks and other networks".
- [17] ITU-T Recommendation T.38: "Procedures for real-time Group 3 facsimile communication over IP networks".
- [18] ITU-T Recommendation X.680: "Information technology - Abstract Syntax Notation One (ASN.1): Specification of basic notation".
- [19] ITU-T Recommendation X.691: "Information technology – ASN.1 encoding rules – Specification of Packed Encoding Rules (PER)".
- [20] IETF RFC 1662: "PPP in HDLC-like Framing".
- [21] IETF RFC 1661: "The Point-to-Point Protocol (PPP)".
- [22] IETF RFC 1570: "PPP LCP Extensions".
- [23] IETF RFC 1332: "The PPP Internet Protocol Control Protocol (IPCP)".
- [24] IETF RFC 791: "Internet Protocol".
- [25] IETF RFC 768: "User Datagram Protocol".

3 Definition and abbreviations

3.1 Definitions

For the purposes of the present document, the following terms and definitions apply:

E-T.38: to use E-T.38 between both the FAs across the radio interface. E-T.38 is based on ITU-T Recommendation T.38, but there are some differences with regards to the packet elements, transcoding methods, and the procedure of controlling signals. The same procedure as T.38 is used for the structure of the frame and the protocol stack (Refer to the following clause, annex A and T.38 for the details).

TAF: TAF usually shows a function of the UE side, but when IWF has the function that is equal to the UE side TAF, TAF is used to express the function of the IWF in the present document.

3.2 Abbreviations

For the purposes of the present document, the following abbreviations apply:

AAAL2	ATM Adaptation Layer type 2
ARQ	Automatic Retransmission Request
BCS	Binary coded signalling
CCT	Circuit(s)
CD	Data Call Direction
CDMA	Code Division Multiple Access
CONTIP	Character Oriented Non-Transparent Protocol
DTCH	Dedicated Traffic Channel
E-T.38	Enhanced T.38
IE	Information element
IFP	Internet Fax Protocol
IP	Internet Protocol
IWF	Interworking Function
I/F	Interface
L2RCOP	Layer 2 Relay Character Oriented Protocol
MAC	Medium Access Control (protocol layering context)
MMI	Man-Machine Interface

MT	Mobile Terminal
PPP	Point to Point Protocol
PSTN	Public Switched Telephone Network
RCSD	Reverse Call Setup Direction
R-FA	Reception side facsimile adaptor that does not have TAF capability
R-FAX	Reception side facsimile
RLC	Radio Link Control
RLP	Radio Link Protocol
R-TAF	Reception side terminal adaptation function
SREJ	Selective reject
TAF	Terminal Adapter Function
TE	Terminal Equipment
T-FA	Transmission side facsimile adaptor that does not have TAF capability
T-FAX	Transmission side facsimile
T-TAF	Transmission side terminal adaptation function
UE	User Equipment
UDP	User Datagram Protocol
UDPTL	Facsimile UDP Transport Layer protocol

The abbreviations for the facsimile specific protocol elements and signals are listed in annex B.

4 Network architecture

4.1 Service definition

The fixed network facsimile group 3 service is an international telematic service for document transmission between two facsimile group 3 terminals.

The service specifications are comprised of two parts:

- the control procedures described in ITU-T Recommendation T.30;
- the document transmission coding described in ITU-T Recommendation T.4.

The UMTS facsimile group 3 Teleservice allows connections between facsimile group 3 terminals using:

- a UMTS PLMN as stand-alone facility for mobile-to-mobile communication;
- a UMTS PLMN to have access to fixed networks PSTN and/or ISDN for mobile to/from fixed network communication.

For this Teleservice, the coding of the facsimile document is as per ITU-T Recommendation T.4 and the protocol as per ITU-T Recommendation T.30 both modified within the PLMN as detailed in the present document.

The interworking between different networks is based on ITU-T Recommendation X.300.

The particular features of this Teleservice are:

- it uses point-to-point communication;
- the information transfer mode is circuit, duplex, asynchronous;
- the information transfer capability is alternate speech/ facsimile group 3 or facsimile group 3 only;
- both mobile originated and mobile terminated calls are supported;
- different end-to-end message speeds as per ITU-T Recommendation T.30 may be used within the same connection to match the appropriate quality requirements;
- use of the standard asynchronous terminal adaptation function for non-transparent network support (as per 3GPP TS 27.002) within the UE is envisaged.

4.2 Network architecture

The network architecture applicable to this Teleservice is shown in figure 1.

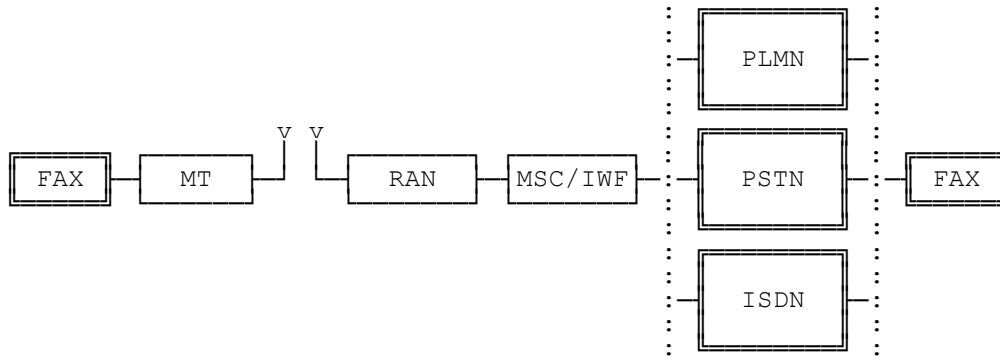

Figure 1: Network architecture

It shows the case of mobile to fixed network interworking. For mobile-to-mobile calls, there would effectively be a loop back within the PLMN using two IWFs.

5 Reference configuration at the mobile station

The user equipment reference configurations described in this clause are defined as per 3GPP TS 27.001.

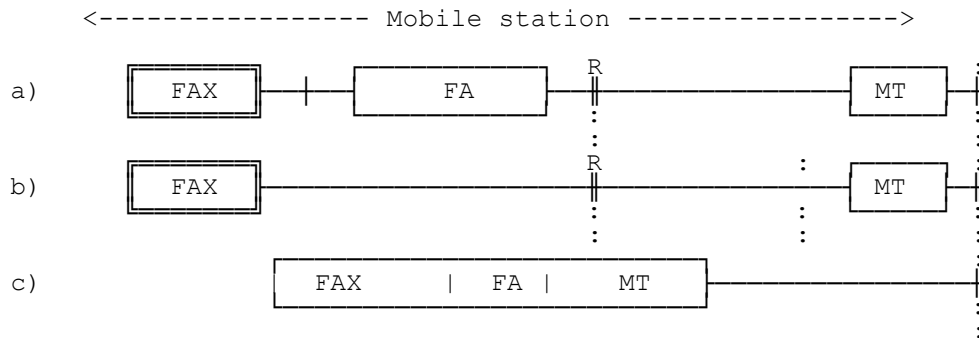

Figure 2: Reference configurations

The teleservice definitions in 3GPP TS 22.003 regard the facsimile group 3 terminal as a 2-wire analogue terminated equipment. In order to connect this to the MT a separate "FA" device is necessary. This configuration, shown in figure 2a, shall be considered as the standard configuration, so that all the existing facsimile group 3 terminals may be connected to the PLMN.

An alternative realization would be to combine a facsimile group 3 terminal and the FA into a special "UMTS facsimile machine", directly providing a digital output. Although such a terminal shall appear to the MT as identical as the FA (i.e. with an identical interface and protocol), it would allow for a significantly smaller and simpler facsimile machine. This configuration is shown in figure 2b.

In addition of course, it is always possible to realize a single device, as per figure 2c, where both the facsimile and mobile termination functions are considered to be part of one integrated unit.

The particular terminal adaptation functions used are those detailed in 3GPP TS 27.002 for non-transparent bearer capability. The interface to the MT used is according to ITU-T Recommendation V.24 with an option for support of 3GPP TS 27.007 procedures for auto calling and auto answering.

5.1 FA functionality

The FA block, figure 3, is intended to specifically complement the facsimile group 3 terminal in order to be able to communicate over a UMTS PLMN.

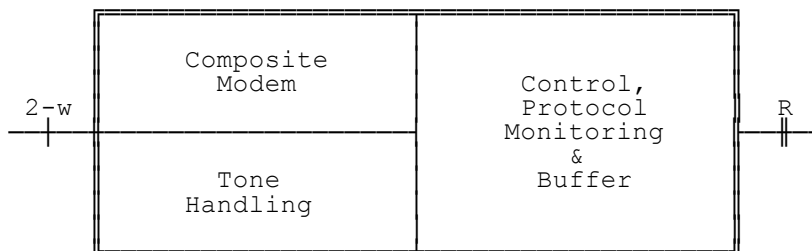

Figure 3: FA scheme

Whether it has to be a function internal to the UMTS PLMN, or an external accessory associated with the facsimile group 3 terminal, is beyond the scope of the present document, and in any case, does not affect the working of the procedure as described here.

It may be functionally partitioned in two sections:

- an analogue section, dealing with:
 - the modulation and demodulation processes according to ITU-T Recommendation V.21, V.27ter, V.29 and V.17 as explained in ITU-T Recommendation T.4 and T.30;
 - handling of the signalling on a 2-wire path to the associated facsimile terminal, including auto calling and auto answering functions where necessary (see clause 7).
- a digital section, dealing with:
 - overall control of the FA;
 - where necessary, manipulating the ITU-T Recommendation T.30 protocol as detailed in the present document;
 - connection to the TAF using the interface according to ITU-T Recommendation V.24 as described in 3GPP TS 27.002;
 - where necessary, auto calling and auto answering functions according to 3GPP TS 27.007.

5.2 UMTS facsimile machine functionality

The special UMTS facsimile machine shown in the UE configuration of figure 2b is similar to the digital part of the FA, but without any of the analogue portions.

It appears at the ITU-T Recommendation V.24 interface as identical as the FA, i.e. the MT needs to have no knowledge of the particular configuration used.

6 Connection types

In UMTS, the following connection elements attributes are applicable to these Teleservices.

Connection element:	Non-transparent
Duplex Mode:	Full Duplex
Synchronous/Asynchronous:	Asynchronous
Fixed Network User Rate:	14 400 or 9 600[bit/s]

Wanted Air User Rate: 28 800 or 14 400[bit/s]

Layer 1 and Layer 2 at R reference point are specified in 3GPP TS 27.002, but not here.

To support the ITU-T Recommendation T.30, requiring different transmission rates, the following strategy shall be implemented:

- the channel on the radio interface in UMTS shall be a channel that is satisfied with a user rate of 28 800 bit/s or 14 400 bit/s;
- the transmission rate between the FA and the associated facsimile terminal at both ends shall be the same, i.e. there shall be only one common end-to-end transmission rate at any given time;
- the message speed shall be negotiated between T-FAX and R-FAX; this also allows for message speeds of 2 400, 4 800, 7 200, 9 600, or 12 000, 14 400 bit/s to be used;
- the connection between the fax terminals is divided into three logical sections (T-FAX -(1)- T-FA-(2)- -R-FA-(3)-R-FAX);
- flag stuffing is applied by the FA towards the associated facsimile terminal within the constraints of ITU-T Recommendation T.30, to keep the data link active whenever a procedure delay occurs;
- the BCS protocol elements and the facsimile coded data are buffered at both FAs , if necessary, to guarantee data integrity;
- a specific FA protocol (FA protocol) is provided between both FAs to cater for appropriate link control.

6.1 Protocol model

Figure 4 depicts the protocol stack for this Teleservice.

Depending on the particular implementation, the R reference point may not explicitly exist. In this case, the Layer2 protocol between the FA and the TAF and consequently the Layer2 protocol between the FA and the TAF entities operating across this interface may be omitted. The protocol stack at the radio interface, however, is not affected by this consideration, i.e. RLP and L2RCOP always apply.

All protocol modules specific for this Teleservice shall be confined in the FA functions at both the UE and MSC/IWF ends. The TAF shall comply with the specifications 3GPP TS 27.001 and 3GPP TS 27.002.

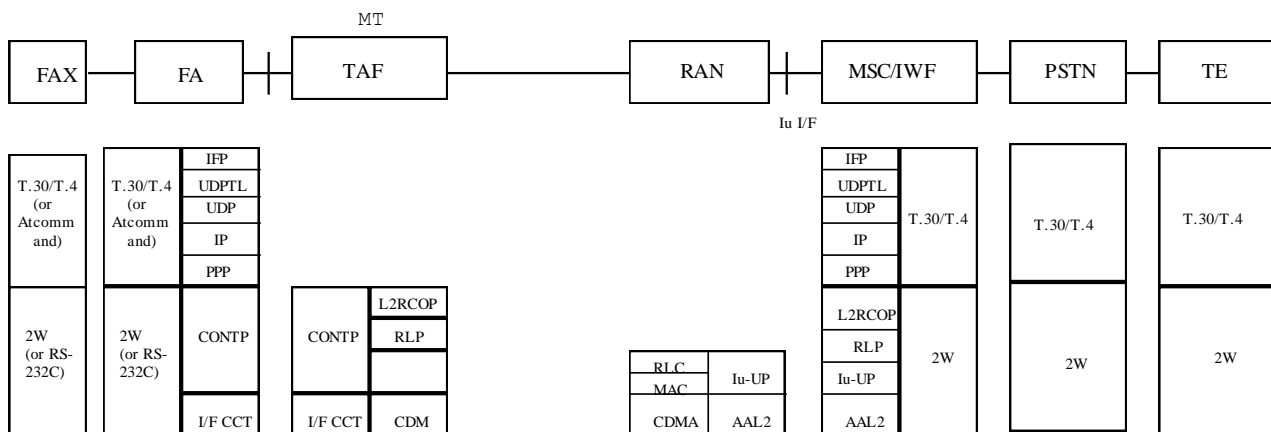

Figure 4: Protocol stack for non-transparent support in UMTS

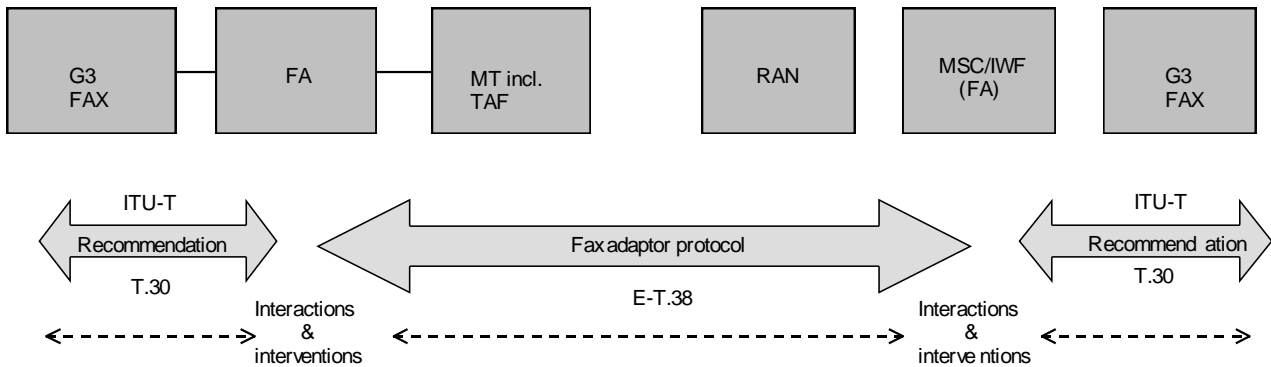

Figure 5: Communication model

6.2 Mobile to mobile calls

Tandem operation shall be applied to mobile to mobile calls.

6.3 Procedure interrupts

Procedure interrupts shall be supported only in Teleservices 61. In the case of Teleservice 62 any attempt to invoke procedure interrupts by MMI on the MT (see subclause 6.4) shall have no effect.

6.4 Radio channel modification

This subclause applies to Teleservice 61 only, if a change of the radio channel during the call swapping from speech to facsimile or vice versa is required. For this purpose the in-call modification procedure (ICM) as detailed in 3GPP TS 24.008 is carried out.

The change from speech to facsimile shall be initiated by MMI at the facsimile terminal starting the ICM procedure via MODIFY signalling.

7 Facsimile adaptor

7.1 Principles of the Facsimile Protocol Adaptation

The basic approach of the present document for facsimile group 3 is:

- to use the ITU-T Recommendation T.30 procedure at both ends of the connection between the FA and the associated facsimile terminal;
- to intervene within the FAs in order to avoid a T.30 timer timeout due to delays in the radio interface;
- to check the message speed; the R-FA selects the appropriate modem indicated by the DIS/DTC frames from the R-FAX. The T-FA switches the appropriate modem according to the TSI/DCS frames from the T-FAX after selecting the modem indicated by the DIS/DTC frames from the R-FA.

Following this strategy, an interchange model is defined concentrating on the facsimile relevant components. According to this model, three connection sections may be distinguished:

- a) between the T-FA and the T-FAX;
- b) between the FAs;
- c) between the R-FA and the R-FAX.

The FAs shall cater for the correct establishment and control of these layers, including traffic channel synchronization and status information exchange, in particular, with respect to circuit 106 and circuit 109 (according to ITU-T Recommendation V.24). Once these circuits have been set to ON (traffic channel synchronization), they shall be kept in the ON condition during the entire facsimile phase of a connection.

7.2 FA functionality

Basically there are four problem areas:

- support of facsimile group 3 with a digital connection type;
- unpredictable delays on the radio interface due to actual RLP working conditions (ARQ);
- the need to change the transmission rate "locally" in the FAs both in the UE and in the MSC/IWF and to adapt it to the constant user rate of the radio interface;
- the inability to support some ITU-T Recommendation T.30 features.

To overcome these problems some particular functions within the FAs are necessary, such as:

- buffering of BCS frames and facsimile coded data prior to transfer;
- autonomous interventions such as BCS frame inhibiting within the FAs;
- provision of a FA protocol (IFP/UDPTL/UDP/IP/PPP) as an interchange protocol between the FAs.

The main features relevant to ITU-T Recommendation T.30 adaptation functions are detailed in the following.

The proper configuration is settled on both network sides by detecting the DIS/DTC frame just at the beginning of the phase B in ITU-T Recommendation T.30 protocol procedure.

The optional error correction mode, as defined in ITU-T Recommendation T.4-Annex A and ITU-T Recommendation T.30-Annex A, may be fully supported, provided some specific features are included in the FA procedure. ECM is optional for the FA.

In order to support ECM:

- additional BCS frames need to be detected;
- the handling of the message phase needs to be adjusted.

The overall framework as described in the present document applies, i.e. it shall be the same mode, ECM or non-ECM, at the transmitting side and the receiving side, because the FA stores FAX signals but does not convert the format of ECM and non-ECM.

The error correction mode is entered upon detection of the relevant bits in the DIS/DTC frame.

The working principle of the present document is based on the detection, control, deletion, and generation of key messages between the:

- the T-FAX and the T-FA;
- the T-FA and the R-FA;
- the R-FA and the R-FAX.

While in BCS phases, the following frames shall be detected:

- DIS/DTC, to monitor all operational parameters of the transmitting terminal;
- CSI, to monitor all operational parameters of the receiving terminal;
- DCS, to realize the actual operational parameters, e.g. message transmission speed accepted by the sender terminal and the relevant message transfer direction (see table 2/ITU-T Recommendation T.30);

- TSI, to indicate that the following FIF information is the identification of the transmitting terminal. It may be used to provide additional security to the facsimile procedures;
- TCF, to verify training and to give a first indication of the acceptability of the channel for this data rate;
- FTT, to reject the training signal and requesting a retrain;
- CTC/EOR, to fix the retransmission strategy by the facsimile transmitting terminal (error correction mode);
- CTR/ERR, to act as the confirmation message and so closing a BCS phase before a new message phase;
- EOM, to indicate the end of a complete page of facsimile information and to return to the beginning of the phase B;
- MPS, to indicate the end of a complete page of facsimile information and to return to the beginning of the phase C upon receipt of a confirmation;
- EOP, to indicate the end of a complete page of facsimile information and to further indicate that no further documents are forthcoming and to proceed to phase E, upon receipt of a confirmation;
- PRI-Q, to indicate the same as EOM/MPS/EOP command with the additional optional capability of requesting operator intervention, therefore PRI-Q is treated as EOM/MPS/EOP;
- DCN, to initiate the call release procedure.

While in BCS phases, the following frames shall additionally be detected. However, these following signals shall not be transmitted to the radio network:

- NSF, to indicate the specific user requirements, which are not covered by ITU-T T-Series Recommendations;
- NSC, to indicate the response to NSF, however this signal is not transmitted to the radio network;
- CFR and MCF, to trigger the message phase;
- PPR, as above, but after the fourth consecutive PPR request, the BCS phase continues with either CTC or EOR (error correction mode);
- RR, to ask for the status of the receiver;
- RTP, to indicate that a complete message has been received and that an additional message may follow after retransmission of training and CFR;
- RTN, to indicate that the previous message has not been satisfactorily received. Several receptions may be possible, provided training is retransmitted;
- PIP/PIN, to indicate that further transmissions are not possible without operator intervention;
- RNR, to indicate that the receiver is not ready to receive more facsimile data;
- ERR, to indicate the response to EOR;
- CRP, to require the retransmission of the previous received signal in errors.

Furthermore, all BCS command messages shall be monitored to eliminate repeated command messages at the FA towards the other FA and to initiate a repetition of those command messages, if necessary, at the FA towards the associated FAX. Additionally, all BCS response messages shall be monitored to be able to clear the former condition.

7.2.1 Packet elements between FAs

To cater for the appropriate facsimile transmission some protocol elements and the related procedures are defined. These protocol elements shall be exchanged between both FAs. They are based on E-T.38 and described as follows. They are structured as outlined in annex A:

IFP packet (see clause A.1 in annex A):

The IFP packet is used to relay ITU-T Recommendation T.30 BCS frames. It includes the possibility also to transmit parts of an entire BCS frame (segmentation).

1) T.30_INDICATOR:

- CNG packet;
- CED packet;
- TCF error detection packet: The TCF error detection packet is used to notify the opposite FA of the TCF error; - FA_busy_packet: The FA_busy_packet is used to notify the T-FA that the R-FA has received the image signal from T-FA;
- FA_non_busy_packet: The FA_non_busy_packet is used to notify the T-FA that the R-FA has received the MCF, RTP or PIP frame from R-FAX.

2) T.30_DATA:

- T.30_DATA conforms to T.38;

Packets defined in T.38 but not used in the present document:

- Training packet;
- V.21 Preamble Flags packet.

7.2.2 Interactions between and interventions within the FAs

Interactions between the FAs and between FA and TAF are necessary:

- where the content of the protocol packets, except NSF and NSC, shall be aligned with the capabilities of the supporting the UMTS PLMN (e.g. figure D.5);
- where the hardware flow control of V.24 shall be adopted for the flow control between the FA and the TAF (refer to 3GPP TS27.002);
- read the facsimile coded data from the buffer, for transmission across the radio interface using the appropriate FA protocol packets (see annex A);
- during the transmission of facsimile coded data where the document content is transcoded to save transmission capacity at the radio interface (see subclause 7.2.4.1);
- write the facsimile coded data received across the radio interface into a buffer at the R-FA;
- where the T-FA distinguishes the phase at the R-FA by using FA_busy_packet and FA_non_busy_packet (see subclause 7.2.1).

To perform the necessary interactions, the FAs at the UE side and at the MSC/IWF side shall monitor the BCS frames (commands/responses) and the facsimile coded data exchanged between the two facsimile terminals and perform the actions detailed below:

- receive the BCS frames from the associated facsimile terminal discarding the BCS frames repetitively received due to time-out in the facsimile terminal;
- store the BCS frames completely received from the associated facsimile terminal;
- change information elements of the BCS frames indicating capabilities which may not be supported by the PLMN (e.g. figure D.5);
- change BCS frames received from the associate FAX into FA protocol packets, and transmit it to the opposite FA (see annex A and refer to ITU-T Recommendations T.38);
- change FA protocol packets received from the opposite FA into BCS frames, and transmit it to the associate FAX (see annex A and refer to ITU-T Recommendations T.38);

- transcode the normal facsimile coded data received from the T-FAX and store the data into a buffer in the T-FA (see subclause 7.2.4.1);

Intervention with in the associated facsimile are necessary:

- control the half duplex connections between the FA and the associated facsimile terminal (refer to ITU-T Recommendation T.30);
- perform phasing/training with the associated facsimile terminal (refer to ITU-T Recommendation T.30).
- transmit the BCS frames to the associated facsimile terminal autonomously repeating the BCS frames towards the accepting facsimile terminal if necessary after time-out or on request by the CRP (e.g. figure D.4);
- where BCS frames shall be repeated autonomously by the FA after a time-out when no response has been received from the associated facsimile terminal (e.g. figure D.18);
- transmit/receive the ITU-T Recommendation T.30 training check frames (TCF) to/from the associated facsimile terminal (refer to ITU-T Recommendation T.30);
- read and reverse transcoding of the buffered normal facsimile coded data and transmitting them to the associated Facsimile terminal (see subclause 7.2.4.1);
- select a appropriate dummy signal (i.e. PPR, FTT, RTC, RTP) : For example, the dummy signal shall be sent to the T-FAX in order to avoid T.30 timer time-out at the turn of phases (e.g. figure D.7);
- adjust the time interval between the transmitted BCS frames (e.g. figure D.5);
- adjust the time interval between receiving a BCS frame and transmitting a response to it (e.g. figure D.14);

The support of guard tones by the FA in the MSC/IWF is an implementation option.

7.2.3 BCS phase

7.2.3.1 BCS command/response procedures

The ITU-T Recommendation T.30 procedures are segmented in sections of associated BCS commands and responses. Any command sent by a facsimile terminal shall be answered by an appropriate BCS response (refer to Appendix III in ITU-T Recommendation T.30). To guarantee that the transmission and reception of responses have the correct timing, the response time after reception of a previous command shall be 75m seconds, when the opposite FA is not busy. When the opposite FA is busy the corresponding timer shall be extended to 2,4 seconds.

According to the command/response relationship, the FA receiving a BCS command from its associated facsimile terminal is called the commanding FA. Similarly, the FA receiving a BCS response is called the responding FA.

The FA shall not transmit the preamble from the associated FAX to the radio network. The opposite FA shall record the BCS frame received from the other FA and transmit the preamble and procedure signal to the associated facsimile within the proper timing. The procedures are as follows:

- 1) BCS command procedures; A BCS command which has been received correctly from the associated facsimile terminal, is stored within the commanding FA. Any forwarding of BCS commands repetitively received from the facsimile terminal is further on inhibited. If an error occurs during the reception of the BCS command from the associated facsimile terminal, the commanding FA shall re-transmit the previously transmitted procedure signal to the associated FAX and request the proper procedure signal. The commanding FA transmits the received BCS frame using "IFP packets" to the radio network. The commanding FA shall not transmit the incorrect procedure signal received from the associated FAX to the radio network.

Contiguously received parts of a BCS command packet received from the radio interface are stored in the responding FA. The stored complete BCS command is used for autonomous transmissions towards the associated facsimile terminal which may start at the earliest possible time according to ITU-T Recommendation T.30.

The responding FA receiving "IFP packets" checks their correct sequence and starts reassembling the BCS command and transmits it when it has been completely received and no sequence error has been detected. All

IFP packets except IFP packets for the next procedure are ignored. The sequence has to be reconstituted at the responding FA before sending it to the associated facsimile terminal.

- 2) BCS response procedures; A BCS response which has been received correctly from the associated facsimile terminal, is stored within the responding FA.

If an error occurs during the reception of the BCS response from the associated facsimile terminal, the responding FA shall re-transmit the previously transmitted procedure signal to the associated FAX and request the proper procedure signal. The responding FA shall not transmit the incorrect procedure signal received from the associated facsimile to the radio network.

Contiguously received parts of a BCS response received from the radio interface are stored in the commanding FA. The stored complete BCS response is used for autonomous answering towards the associated facsimile terminal which may start at the earliest possible time according to ITU-T Recommendation T.30.

After transmission of a response towards the FA/fax terminals by the FA function, after which the FA function waits for message data (CFR, CTR, MCF after MPS, PPS_MPS, PPS_NULL, ERR after EOR_MPS, EOR_NULL) a repeated BCS command shall be locally responded, without transferring a preamble element towards the radio link.

The FA shall take care of the control of the local modem. The condition is derived from the reception of certain FA protocol elements. Additionally, there shall be a control of the half duplex transmission path towards the associated facsimile terminal. For that purpose, the receiver signal is monitored and the transmitter is activated, only if no receive signal is active.

7.2.3.2 Compatibility checking

Some features shall not be supported in the UMTS PLMN environment. The FA is in charge of dealing with such compatibility checking which is carried out by monitoring certain BCS frames (DIS/DTC).

- Group 1 and group 2 equipments shall not be supported by the Teleservice as described in the present document.
- Error limiting mode shall not be supported.
- Only standard 300 bit/s Binary Coded Signalling shall be supported. For this purpose, the FA shall ignore the 2400 bit/s capability within phase B of the ITU-T Recommendation T.30 procedure by looking for DIS frames from ITU-T Recommendation V.21 modem only.
- The following facsimile message speeds shall be supported: 2400, 4800, 7200, 9600, 12000 and 14400bit/s. For this purpose the FAs are responsible to carry out appropriate actions, e.g. to set the applicable fields in the DIS frame accordingly.
- It is not possible to support non-standard facilities since some of these contain proprietary methods of changing the modem speed that are un-interpretable to the IWF and hence impossible to track.

7.2.3.3 Training Check

The training check sequence (TCF) as described in ITU-T Recommendation T.30 is exchanged only locally between the FA and the associated facsimile terminal. The training check sequence sent by the FA shall be transmitted at the earliest possible time, and shall have a duration that complies with the minimum duration requirement of ITU-T Recommendation T.30. Because CFR is not transmitted end to end the T-FA generates CFR or FTT, and sends it to the T-FAX.

The T-FA shall send CFR to the T-FAX, 2.4s after it received TCF from the T-FAX.

However in the following cases, the T-FA shall send FTT to the T-FAX instead of CFR (see figure D.7):

- when it receives the TCF error detection packet from the R-FA;
- when it receives the FTT packet from the R-FA;
- when it recognizes the R-FA busy status by the FA_busy_packet.

(The T-FA shall transmit FTT to avoid the phase difference between the transmitting and the receiving side when the phase is returned to phase B by EOM.)

This is done by using the FA_busy_packet and the FA_non_busy_packet to monitor the state of the R-FA. When the T-FA receives the FA_busy_packet it can deduce that the training has been successful on the receiving side.

As a consequence of this local procedure, the T-FA shall check the received TCF to see whether the quality requirements are satisfied. Depending on the result of that check, the T-FA recognizing a corrupted line shall send FTT instead of CFR. If the T-FA receives corrupted TCF from the T-FAX, it shall transmit the TCF_error_detection_packet to the R-FA. On the other hand, if the R-FA receives the TCF_error_detection_packet from the radio network, it shall transmit a corrupted TCF to the R-FAX (see figure D.7).

The message transfer phase in the R-FA shall be entered upon reception of CFR. The modem training at transmission speed shall start after the R-FA receives the facsimile coded data if it receives the data within 3 s after the receipt of CFR from the R-FAX (see figures D.5 and D.9).

The R-FA shall transmit the TSI, DCS to the R-FAX, if it does not receive the facsimile coded data within 3,0 s after the receipt of the CFR from the R-FAX (see figures D.5 and D.9).

7.2.3.4 Control of transmission rate

The controlling entity of the FA shall recognize a change of the transmission rate, and in conjunction with this a change of the modem function has to commence. The transmission rate shall be changed only locally, i.e. between the facsimile terminal and the FA at both the MSC/IWF and the UE ends.

The actual message speed and the modem function are derived from the content of the related BCS frames (DIS/DTC, DCS, CTC).

There are two methods to decide the transmission rate as follows:

- Use DIS DCS signal between FAXs (see figures D.4 and D.5);
- Trigger Fallback by the TCF error detection.

Fallback is triggered both on the transmitting and receiving sides.

In the case that fallback occurs on the transmitting side, the R-FA shall be notified of the fact by the TCF error detection packet (see figure D.9).

In the case that fallback occurs on the receiving side, the T-FA shall be notified of the fact by the FTT packet from the R-FA (see figure D.7).

7.2.4 Message phase

During the message phase (phase C of ITU-T Recommendation T.30) the EOL character shall be detected, (see subclause 4.1.2 of ITU-T Recommendation T.4). The EOL character is a unique code word that may never be found within a valid line of facsimile coded data, and is used:

- to identify the start of the message phase;
- to control the transcoding procedure;
- to mark the end of the message phase (6 consecutive EOLs).

If the R-FA has stored more than 0,28 kbyte of facsimile coded data and detected two or more EOLs in the data, then the R-FA shall send the FA_busy_packet to the T-FA. After the R-FA receives MCF from the R-FAX, the R-FA shall send the FA_non_busy_packet to the T-FA. The R-FA shall notify the T-FA of the state of the reception side by sending the FA_busy_packet or the FA_non_busy_packet to avoid that the phase at the T-FA proceeds the next phase (as a result of EOP, MPS, EOM, CTC, PPS-Q, EOR-Q, RR) while the R-FA is still busy in the current phase.

7.2.4.1 Message Transcoding

To save transmission capacity at the radio interface the content of the document shall be transcoded. This applies only when using the normal facsimile data transfer. This does not apply when using the ITU-T Recommendation T.30 error correction mode.

The facsimile coded data received by the T-FA from the T-FAX is transcoded and transmitted to the corresponding R-FA across the radio interface. Then it is transcoded and transmitted to the R-FAX by R-FA.

The transcoding is based on the minimum line length capability of the T.30 protocol for the normal facsimile data transfer. According to this the transmitting facsimile terminal has to fill up each coded scan line with FILL information to conform to this requirement (refer to ITU-T Recommendation T.4).

To do so, the FA associated with the T-FAX shall force this to use (at least) the standard value of 20 ms by replacing the applicable parameter value of the exchanged DIS/DTC messages. All FILL information of the facsimile coded data received from the FAX shall be deleted prior to forwarding the data across the radio interface. The FA associated with the R-FAX shall recognize and store the originally requested minimum line length to be able to regenerate to correct line length.

It should be noted that ITU-T Recommendation T.4 document coding may be 1-dimensional or 2-dimensional and, in addition, uncompressed. The FAs shall take care of this when transcoding the document content.

7.2.4.2 Generation of the normal data packet

This is specified in ITU-T Recommendations T.38 and X.691. X.691 provides details on octet alignment.

7.2.4.3 Generation of the error correction data packet

This is specified in ITU-T Recommendations T.38 and X.691. X.691 provides details on octet alignment.

7.2.4.4 Normal facsimile data

The T-FA starts the message phase by transmitting CFR or MCF to the T-FAX. The R-FA enters the message phase by receiving CFR or MCF from the R-FAX.

- If the R-FA does not receive the facsimile coded data from the radio network within 3s of receiving CFR from the R-FAX, it shall re-transmit a preamble of 1.0s and the previously transmitted TSI, DCS to the R-FAX after changing the modem to V.21.
- If the R-FA does receive the facsimile coded data from radio network within 3s of receiving CFR from the R-FAX, it shall transmit the training to the R-FAX after changing the modem to V.17, V.27ter or V.29.
- If the R-FA does not receive the facsimile coded data from the radio network within 3s of receiving MCF from the R-FAX, it shall re-transmit a preamble of 1.0s and the previously transmitted MPS to the R-FAX after changing the modem to V.21.
- If the R-FA does receive the facsimile coded data from the radio network within 3s of receiving MCF from the R-FAX, it shall transmit the training to the R-FAX after changing the modem to V.17, V.27ter or V.29.

Following the training sequence, the R-FA shall transmit FILL towards the R-FAX (see subclause 4.1.2 of ITU-T Recommendation T.4), disregarding all information received from the radio interface, until an EOL character is detected, which shall mark the beginning of the image data (see figure 1 of ITU-T Recommendation T.4).

If due to a preceding error the message phase may not be entered, the training sequence shall be aborted when a new IFP packet is received by the T-FA.

7.2.4.5 Error correction facsimile data

As the facsimile coded data between the FA and the facsimile terminal are structured in HDLC frames, the handling of this procedure segment shall exploit such formatting. The content of such an HDLC frame is called a block (refer to ITU-T Recommendation T.4 Annex A).

Each such block is included in the information field of an Error_Correction_Data_Packet of the FA protocol, which is processed for transmission across the radio interface as outlined in subclause 7.2.4.3.

The message phase at both the PLMN ends is triggered by the transit of a confirmation frame (CFR, MCF, PPR, CTR or ERR) sent by the receiving terminal and marking the end of the BCS phase.

The PPR that the T-FA sends to the T-FAX has two purposes:

- PPR is used to request re-transmission of the facsimile coded data. When the T-FA receives corrupted facsimile coded data, it requests correct facsimile coded data to the T-FAX (refer to ITU-T Recommendation T.30).
- In addition to the T.30 purpose, PPR is used to avoid the timer timeout of the T.30 protocol. If the R-FA is busy, the T-FA shall transmit PPR to the T-FAX (see figure D.20).

If four consecutive PPR are counted within the same "partial page", the BCS phase continues.

The T-FA shall enter the message phase as described in ITU-T Recommendation T.30.

- If the R-FA does not receive the facsimile coded data from the radio network within 3s of receiving CFR from the R-FAX, it shall re-transmit a preamble of 1.0s and the previously transmitted TSI, DCS to the R-FAX after changing the modem to V.21.
- If the R-FA does receive the facsimile coded data from radio network within 3s of receiving MCF from the R-FAX, it shall transmit the training to the R-FAX after changing the modem to V.17, V.27ter or V.29.
- If the R-FA does not receive the facsimile coded data from the radio network within 3s of receiving MCF from the R-FAX, it shall re-transmit a preamble of 1.0s and the previously transmitted MPS to the R-FAX after changing the modem to V.21.
- If the R-FA does receive the facsimile coded data from the radio network within 3s of receiving MCF from the R-FAX, it shall transmit the training to the R-FAX after changing the modem to V.17, V.27ter or V.29.

Following the training sequence, HDLC flags shall be stuffed into the signal sent to the facsimile terminal until a FCD frame is detected, which shall mark the beginning of the image data.

If due to a preceding error the message phase may not be entered, the training sequence shall be aborted when a new IFP packet is received by the T-FA.

7.2.4.6 Controlling of facsimile coded data

The procedure for controlling the FAX data within the FA is described in the following two subclauses.

It is recommended that the buffer size inside FA is more than 256 kbytes.

7.2.4.6.1 Transmitting Fax Adapter

In the T-FA the facsimile coded data being received from the T-FAX are transcoded stripping of FILL information and written into the buffer.

When data is read out from the buffer, an FA protocol element shall be generated and processed as described in Annex A or ITU-T Recommendation T.38. It is transferred to the R-FA using one of the standard FA protocol element. For that purpose the data shall be segmented into blocks.

Due to the ARQ techniques of the RLP, the throughput across the radio interface may be less than the message speed between the T-FAX and the T-FA, i.e. the content of the buffer may increase.

If the throughput at the radio interface is greater than the message speed between the T-FAX terminal and the T-FA (e.g. when the end to end speed is lower than 14400 bit/s), the buffer may be empty most of the time.

7.2.4.6.2 Receiving Fax Adapter

In the R-FA, FILL information is transmitted to the R-FAX at the beginning of each page, if necessary, to bridge the gap between the training sequence and the reception of the image data. In case of normal fax data, the duration of the FILL 0's may be increased by only 4,5 s or less.

The reverse transcoding consists of the insertion of FILL information before the facsimile coded data is forwarded to the facsimile terminal to comply with the recognized minimum line length as defined in ITU-T Recommendation T.4.

At the beginning of each page, the facsimile coded data to be sent to the facsimile terminal is not read out from the buffer until either at least 2 instances of EOL have been received and the buffer size is at least 0,28 kbytes or, an RTC has been received, which does not depend on the end-to-end data transfer rate.

7.2.4.6.2.1 Fill insertion method for NON- ECM

The R-FA controls FILL insertion according to the accumulation value of image signals (see figure D.11).

The condition for starting FILL insertion:

- when the pix memory accumulation value is 0,28 kbytes or less.

The condition for stopping FILL insertion:

- when the pix memory value is 0,9 kbytes or more;
- when the pix memory value is not over 0,9 kbytes and the interval between EOLs (one line period) reaches 4,5 s.

When the interval between EOL reaches 4,5 s, the R-FA shall stop FILL insertion, and shall transmit EOL and shall start to transmit the next facsimile coded line. If however the pix memory value is below "the forced RTC transmission value"(=7byte or less), the R-FA shall send RTC to the R-FAX to force end of Phase C. Then it shall wait for a post-message (EOP, EOM, MPS) to be received from the air interface.

7.2.4.6.2.2 Flag insertion method for ECM

The R-FA controls Flag insertion according to the accumulation value of the image signals(see figure D.13).

The condition for starting Flag insertion:

- when pix memory accumulation value is 0,28 kbytes or less.

The condition for stopping Flag insertion:

- when the pix memory value is 0,9 kbytes or more.

7.2.5 Disconnect procedure

The T-FA sends the MCF frame to the T-FAX after receiving the FA_non_busy_packet from the R-FA. The T-FAX sends the DCN frame (see ITU-T Recommendation T.30) to the T-FA after receiving the MCF frame. The T-FA, upon detection of the DCN frame sent by the T-FAX to indicate the end of the facsimile transmission, shall initiate the disconnect procedure. The T-FA transmits the DCN packet to the R-FA after receiving the DCN frame from the T-FAX, while the R-FA transmits the DCN frame to the R-FAX after receiving the DCN packet.

7.2.6 Timeouts

The T.30 timer between the T-FAX and the T-FA, and the T.30 timer between the R-FAX and the R-FA are independent of each other. Therefore, the overall fax adaptation function is in principle bound to the timing constraints associated with the associated FAX ITU-T Recommendation T.30 procedure. This means that, no matter of the reference configuration used at the mobile station, the progress of the call shall be mainly subject to the ITU-T Recommendation T.30 typical timing protections, settled externally.

However, due to the specific conditions caused by the UMTS PLMN system, there is the need for a special support with respect to BCS command repetitions as explained above. For that purpose, the FAs shall provide means for local time-out. The timer shall be started and stopped as described in annex D (see table D.2).

8 Use of terminal adaptation functions

The protocol stack of the connection type is shown in figure 4.

The TAFs described in 3GPP TS 27.002 for asynchronous bearer capabilities in the non-transparent mode. The interchange signalling mapping is in accordance with 3GPP TS 27.002.

8.1 Principles of terminal adaptation functions

The TAF, located at both PLMN ends, is in charge of:

- call set-up, in particular the BC negotiation;
- establishment and maintenance of a Layer2 protocol link between the FA and the TAF according to 3GPP TS 27.002, where applicable;
- establishment and maintenance of an L2RCOP link between the TAFs according to 3GPP TS 27.002;
- initiation of the In-Call Modification (ICM) procedure.

The basic approach of the present document for facsimile group 3 is:

- to use the network support of BS 20 NT as defined in 3GPP TS 27.001, 3GPP TS 27.002 and 3GPP TS 29.007.

8.2 Specific TAFs for facsimile service

In order to perform the procedures described in the present document, the UE and the IWF environment shall be designed to transmit and receive facsimile data continuously with flow control. This specifically applies between RLP entities, L2RCOP (within TAF) entities, and between the FA and the TAF entities within the UE or the IWF.

Furthermore, the RLP entity shall be able to make error recovery by using the SREJ command/response.

9 Signalling aspects

3GPP TS 27.002 identifies the bearer capability requirements to be supported by the terminal adaptation function in the MT (see 3GPP TS 27.001 for BC and HLC coding). The specific signalling requirements are those for "speech" and "facsimile group 3" or "facsimile group 3" only, respectively. The MT indicates in the call set up request the requirements, e.g. first speech, second facsimile by sending the bearer capability information element(s) in the appropriate order. For an "auto calling" facsimile request, the facsimile group 3 bearer capability is sent as the first or the only bearer capability for Teleservice 61 or 62, respectively.

For interworking between Teleservice 61 and Teleservice 62, refer to 3GPP TS 22.003 and 3GPP TS 27.001.

9.1 Handling of tonal signals

Because the ITU-T defined service uses modems, there are some signals received from the analogue link at the MSC/IWF and (where used) the FA which do not have a direct binary representation.

These signals are the modem called (CED) and calling (CNG) tones sent at the start of each fax data phase of the call. These tonal signals shall be used for the selection of ATD or ATA. No later than 3 sec after connecting the fax apparatus to the line the FA/UE is able to determine the AT command. If a CNG tone or nothing is detected by the FA/UE the mobile fax station is the calling station, if a CED tone or a BCS signal frame is detected by the FA/UE the mobile fax station is the called station. If the associate fax is the calling station, the FA shall transmit ATD toward the TAF. If the associate fax is the called station, the FA shall transmit ATA toward the TAF.

After the link of the FA_protocol is established, these tonal signals shall be sent to the opposite FA as the IFP_packet(CNG,CED). The FA receiving the FA_packet(CNG,CED) shall generate the tonal signal and transmit the signal toward the associated facsimile terminal. (see figure D.3)

9.2 Call establishment

9.2.1 Mobile terminated call

The call may be set-up manually or automatically by the PSTN facsimile group 3.

9.2.1.1 Speech then facsimile

Refer to the diagrams in figures C.1a and C.1b. In both of the figures, the initial call setup is mobile terminated. In figure C.1a, the DCD is also mobile terminated (MT), while the DCD in figure C.1b is mobile originated (MO).

The connection of the FA to the TAF causes the initialization between the FA and the TAF. At this time, the setting of speech/facsimile call should be done in the FA. The operation of the FA for the speech/facsimile call setting is implementation dependent.

At first, the FA at the UE shall turn on circuit 108/2 and circuit 105. After that, the TAF at the UE shall turn on circuit 106 and circuit 107 toward the FA. The FA which detected ON condition of circuit 106 and circuit 107 requires facsimile call of the TAF by appropriate AT command (e.g. AT+CMOD=1, AT+FCLASS=1, 2). If the AT command is recognized, the TAF shall transmit "OK" to the FA as a result code.

In order to make the transition from the speech phase to the facsimile phase, the MODIFY message shall be initiated by the MMI at the facsimile terminal, which shall result in the establishment of RLP across the radio interface and connection to the line of the FA/IWF.

When the facsimile machine is connected to the line by manual intervention, the facsimile machine should transmit tonal signal (CNG or CED) toward the FA. The FA shall select ATD or ATA according to the rules in subclause 9.1 and transmit ATD or ATA toward the TAF.

On detecting ATD or ATA, the TAF shall transmit the MODIFY message that has G3FAX ability as a bearer capability. After that, RLP and L2RCOP shall be established across the radio interface. Once the connection is established, circuit 109 shall be clamped to the ON condition by the TAF at the IWF. Then, the FA protocol shall be started between the FAs.

9.2.1.2 Auto answer

Refer to the diagram in figure C.2. The connection of the FA to the TAF causes the initialization between the FA and the TAF. At first, the FA at the UE shall turn on circuit 108/2 and circuit 105. After that, the TAF at the UE shall turn on circuit 106 and circuit 107 toward the FA. The FA which detected ON condition of circuit 106 and circuit 107 shall require facsimile call of the TAF by appropriate AT command (e.g. AT+FCLASS=1, 2). If the AT command is recognized, the TAF shall transmit "OK" to the FA as a result code.

When the MT receives a call in the condition finished the above initialization, the TAF shall transmit the result code "RING" toward the FA. "RING" shall cause a ring current to be sent to the facsimile terminal. The FA shall transmit ATA toward the TAF when the FAX terminal connects to the line and begins behaviour of receiving. On receiving ATA, the FA shall transmit a signal that notifies the calling side that called facsimile terminal connected to the line.

Once the connection is established, circuit 109 shall be clamped to the ON condition by the TAF at the IWF. Then, the FA protocol shall be started between the FAs.

9.2.2 Mobile originated calls

The PSTN facsimile group 3 terminal may manually or automatically answer the call originated by the mobile station.

9.2.2.1 Speech then facsimile

Refer to the diagrams in figure C.3a and figure C.3b. In both of the figures, the initial call setup is mobile originated. In figure C.3a the DCD is also MO, while in figure C.3b the DCD is MT.

The connection of the FA to the TAF causes the initialization between the FA and the TAF. At this time, the setting of speech/facsimile call should be done in the FA. The operation of the FA for the speech/facsimile call setting is implementation dependent.

At first, the FA at the UE shall turn on circuit 108/2 and circuit 105. After that, the TAF at the UE shall turn on circuit 106 and circuit 107 toward the FA. The FA which detected ON condition of circuit 106 and circuit 107 requires facsimile call of the TAF by appropriate AT command (e.g. AT+CMOD=1, AT+FCLASS=1, 2). If the AT command is recognized, the TAF shall transmit "OK" to the FA as a result code.

In order to make the transition from the speech phase to the facsimile phase, the MODIFY message shall be initiated by the MMI at the facsimile terminal, which shall result in the establishment of RLP across the radio interface and connection to line of the FA/IWF.

When the facsimile machine is connected to the line by manual intervention, the facsimile machine should transmit tonal signal (CNG or CED) toward the FA. The FA shall select ATD or ATA according to the rules in subclause 9.1 and transmit ATD or ATA toward the TAF. On detecting ATD or ATA, the TAF shall transmit the MODIFY message that has G3FAX ability as a bearer capability. After that, RLP and L2RCOP shall be established across the radio interface. Once the connection is established, circuit 109 shall be clamped to the ON condition by the TAF at the IWF. Then, the FA protocol shall be started between the FAs.

9.2.2.2 Auto calling

Refer to the diagram in figure C.4. The FA at the UE shall turn on circuit 108/2 and circuit 105 when the fax apparatus is connected to the line by manual intervention. After that, the TAF at the UE shall turn on circuit 106 and circuit 107 toward the FA. The FA which detected ON condition of circuit 106 and circuit 107 shall require facsimile call of the TAF by appropriate AT command (e.g. AT+FCLASS=1, 2). If the AT command is recognized, the TAF shall transmit "OK" to the FA as a result code.

The FA shall make ATD [Dial signal] from DTMF dialling information and transmit ATD[Dial signal] toward the TAF. On detecting ATD [Dial signal], the TAF shall transmit the call set-up signal that has G3FAX ability as a bearer capability. When the call is answered, the synchronization process shall be started and the RLP shall be established across the radio interface.

After that, RLP and L2RCOP are established across the radio interface. Once the connection is established, circuit 109 shall be clamped to the ON condition by the TAF at the IWF. Then, the FA protocol is started between the FAs.

9.2.2.3 Manual calling

Refer to the diagram in figure C.5. The connection of the FA to the TAF causes the initialization between the FA and the TAF. At first, the FA shall turn on circuit 108/2 and circuit 105. After that, the TAF at the UE shall turn on circuit 106 and circuit 107 toward the FA. The FA which detected ON condition of circuit 106 and circuit 107 shall require facsimile call of the TAF by appropriate AT command (e.g. AT+FCLASS=1, 2). If the AT command is recognized, the TAF shall transmit "OK" to the FA as a result code.

After the initialization of the FA and the TAF, the dialling operation shall be done at the MT. Then, the MT shall transmit the call set-up signal that has G3FAX ability as a bearer capability.

After that, RLP and L2RCOP shall be established across the radio interface. Once the connection is established, circuit 109 shall be clamped to the ON condition by the TAF at the IWF. Then, the FA protocol shall be started between the FAs. And the fax apparatus is connected to the line by manual intervention.

10 Interworking to fixed networks

Only PSTN and ISDN are considered, and may be used as transit networks to complement the PLMN in the end-to-end connection between facsimile group 3 terminals (figure 6).

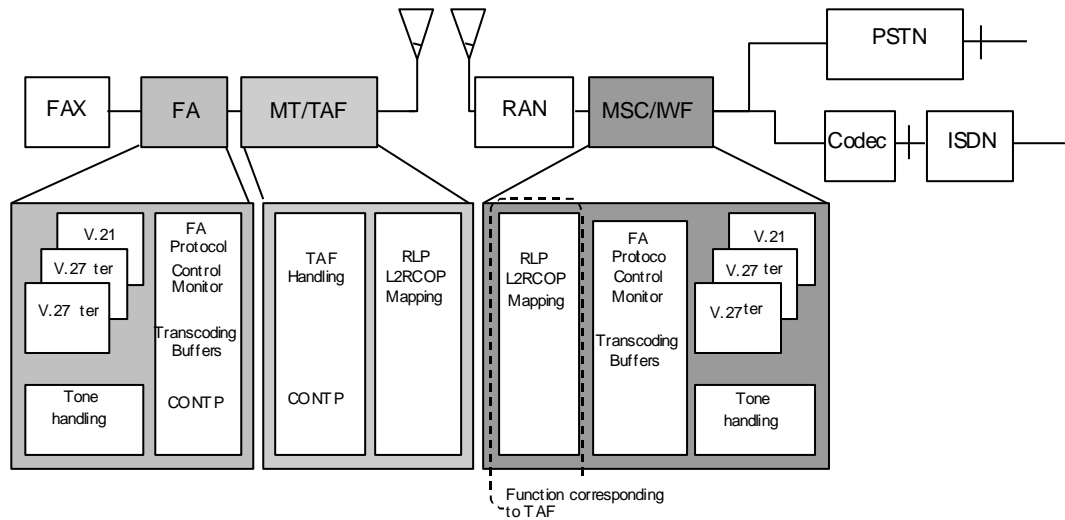

Figure 6: Network interworking

10.1 Interworking to PSTN

As the standard access of facsimile group 3 terminals for this Teleservice is a 2-wire analogue interface, all the technical requirements for network interworking to PSTN are identical in principle to those encountered for the terminal connection to the UE. The key functional block is the FA described in clause 7 of the present document.

As far as network interworking is concerned, the main function to be performed by such a block is the correct managing of a composite modem, in accordance with the requirements of ITU-T Recommendation T.30:

- ITU-T Recommendation V.21 synchronous mode, as standard facility for all BCS phases;
- ITU-T Recommendation V.27ter for message speeds of 4 800 and 2 400 bit/s;
- ITU-T Recommendation V.29 for message speeds of 9 600 and 7 200 bit/s;
- ITU-T Recommendation V.17 for message speeds of 14 400, 12 000, 9 600, 7 200 bit/s.

The mechanism for selecting the correct modem is the following:

- the actual message speed is obtained by detecting the DCS frame (see table 2/ITU-T Recommendation T.30) while in BCS phase;
- on entering the message phase, there is an interchange between the V.21 modem and the actual modem agreed upon between the terminals for message transmission;
- on exiting the message phase (RTC) the ITU-T Recommendation V.21 modem is selected again.

Times for settling the modem shall be in accordance with the requirements of ITU-T Recommendation T.30.

10.2 Interworking to ISDN

The use of 3,1 kHz audio bearer capability of ISDN allows for an interworking of PLMN very similar in practice to the scheme for PSTN (figure 6). The FA function shall comply with the description given in clause 7 of the present document.

Annex A (normative): Structure and contents of the FA protocol elements

A.1 Internet Fax Protocol

This ANNEX is related to the application of the T.38 protocol within the present document.

Only the following packets are used:

- T30_INDICATOR
 - CNG
 - CED
 - TCF error detection (not in T.38)
 - FA_busy_packet (not in T.38)
 - FA_non_busy_packet (not in T.38)
- T30_DATA
 - V.21 channel 2 (except MCF, CFR, RTN, RTP, PIP, PIN, PRI, PPR, NSF, NSC, RR, RNR, ERR)
 - V.27 ter 2400
 - V.27 ter 4800
 - V.29 7200
 - V.29 9600
 - V.17 7200
 - V.17 9600
 - V.17 12000
 - V.17 14400

In T30_DATA the maximum length of T.4-Non-ECM/HDLC data is equal to 1 400 octets.

Aligned Packet Encoding Rule is applied to ASN.1.

A.2 Facsimile UDP Transport Layer Protocol

The FEC option and the redundant message option shall not be used.

A.3 User Datagram Protocol

The port number at client side is ephemeral (assigned on a call by call basis). The port number at the server side is manually preassigned by the operator.

A.4 Internet Protocol

The IP address is not required because a circuit switched connection is used between the UE and IWF. However, IP addresses shall be used in order to be consistent with IP.

The IP address at UE side and IWF side are assigned by PPP.

A.5 Point to Point Protocol

For the communication between the two FAs IP is provided on top of PPP.

PPP shall conform to RFC 1662, 1661, 1570 and 1332.

A.6 Mapping of FA frames

Refer also to 3GPP TS 27.002.

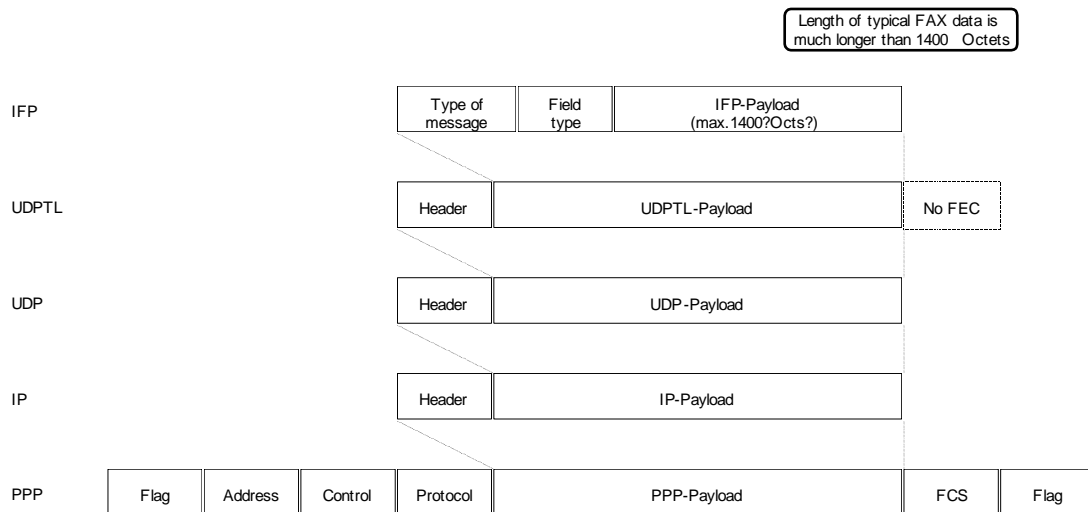

Figure A.1: Typical frame mapping within FA protocol

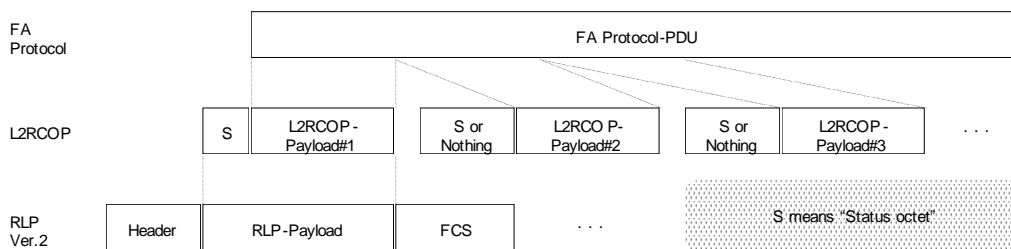

Figure A.2: Typical frame mapping between FA Protocol and RLP

Annex B (informative): Abbreviations from ITU-T Recommendation T.30 and T.4

Table B.1: Abbreviations from ITU-T Recommendation T.30

Abbreviation	Function	Signal format	T.30 standard	T.30 err.corr.
CED	Called station identification	2100 Hz	X	X
CFR	Confirmation to receive	X010 0001	X	X
CRP	Command repeat	X101 1000	X	X
CIG	Calling subscriber identification	1000 1000	X	X
CNG	Calling tone	1100 Hz	X	X
CSI	Called subscriber identification	0000 0010	X	X
CTC	Continue to correct	X100 1000		X
CTR	Response to continue to correct	X010 0011		X
DCN	Disconnect	X101 1111	X	X
DCS	Digital command signal	X100 0001	X	X
DIS	Digital identification signal	0000 0001	X	X
DTC	Digital transmit command	1000 0001	X	X
EOM	End of message	X111 0001	X	
EOP	End of procedure	X111 0100	X	
EOR	End of retransmission	X111 0011		X
ERR	Response to end of retransmission	X011 1000		X
FCD	Facsimile coded data	0110 0000		X
FCF	Facsimile control field	---	X	X
FCS	Frame checking sequence	16 bits	X	X
FIF	Facsimile information field	---	X	X
FTT	Failure to train	X010 0010	X	X
MCF	Message confirmation	X011 0001	X	X
MPS	Multi-page signal	X111 0010	X	
NSC	Non-standard facilities command	1000 0100	X	X
NSF	Non-standard facilities	0000 0100	X	X
NSS	Non-standard set-up	X100 0100	X	X
PIN	Procedural interrupt negative	X011 0100	X	X
PIP	Procedural interrupt positive	X011 0101	X	X
PIS	Procedure interrupt signal	462 Hz	X	X
PPR	Partial page request	X011 1101		X
PPS	Partial page signal	X111 1101		X
PRI	Procedure interrupt	X111 XXXX	X	
RCP	Return to control for partial page	0110 0001		X
RNR	Receive not ready	X011 0111		X
RR	Receive ready	X111 0110		X
RTN	Retrain negative	X011 0010	X	X
RTP	Retrain positive	X011 0011	X	X
TCF	Training check frame	0... 1.5s	X	X
TSI	Transmitting subscriber identification	X100 0010	X	X

Table B.2: Abbreviations from ITU-T Recommendation T.4

Abbreviation	Function	Signal format
EOL	End of line	0000 0000 0001
RTC	Return to control	6 * EOL

Annex C (informative): Procedure examples

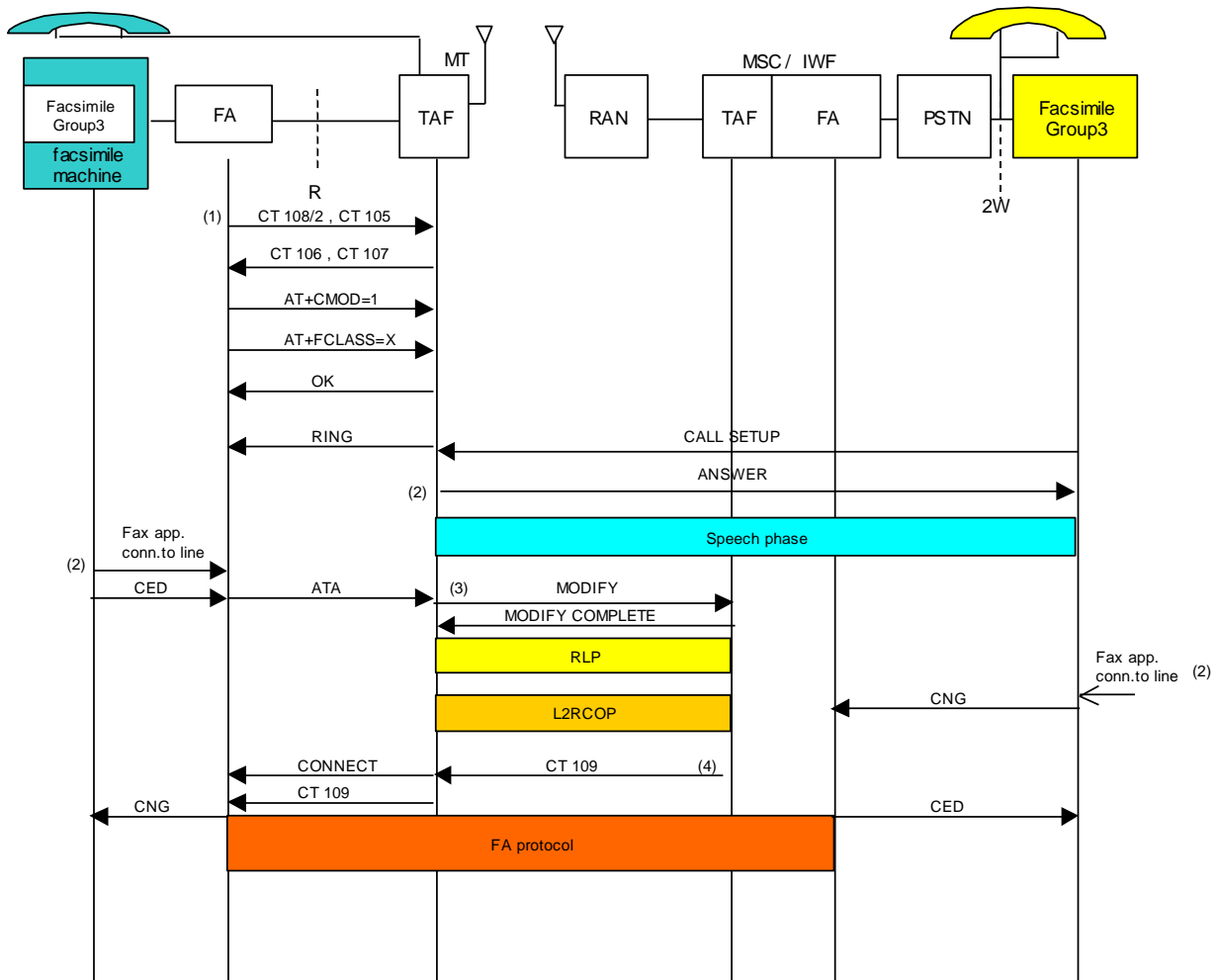

105, 106, 107, 108/2, 109: circuits according to ITU-T Recommendation V.24

- (1) speech/fax call setting
- (2) manual intervention
- (3) triggered by ATA
- (4) locally generated by the IWF

Figure C.1a: Mobile terminated call - speech then facsimile DCD mobile terminated

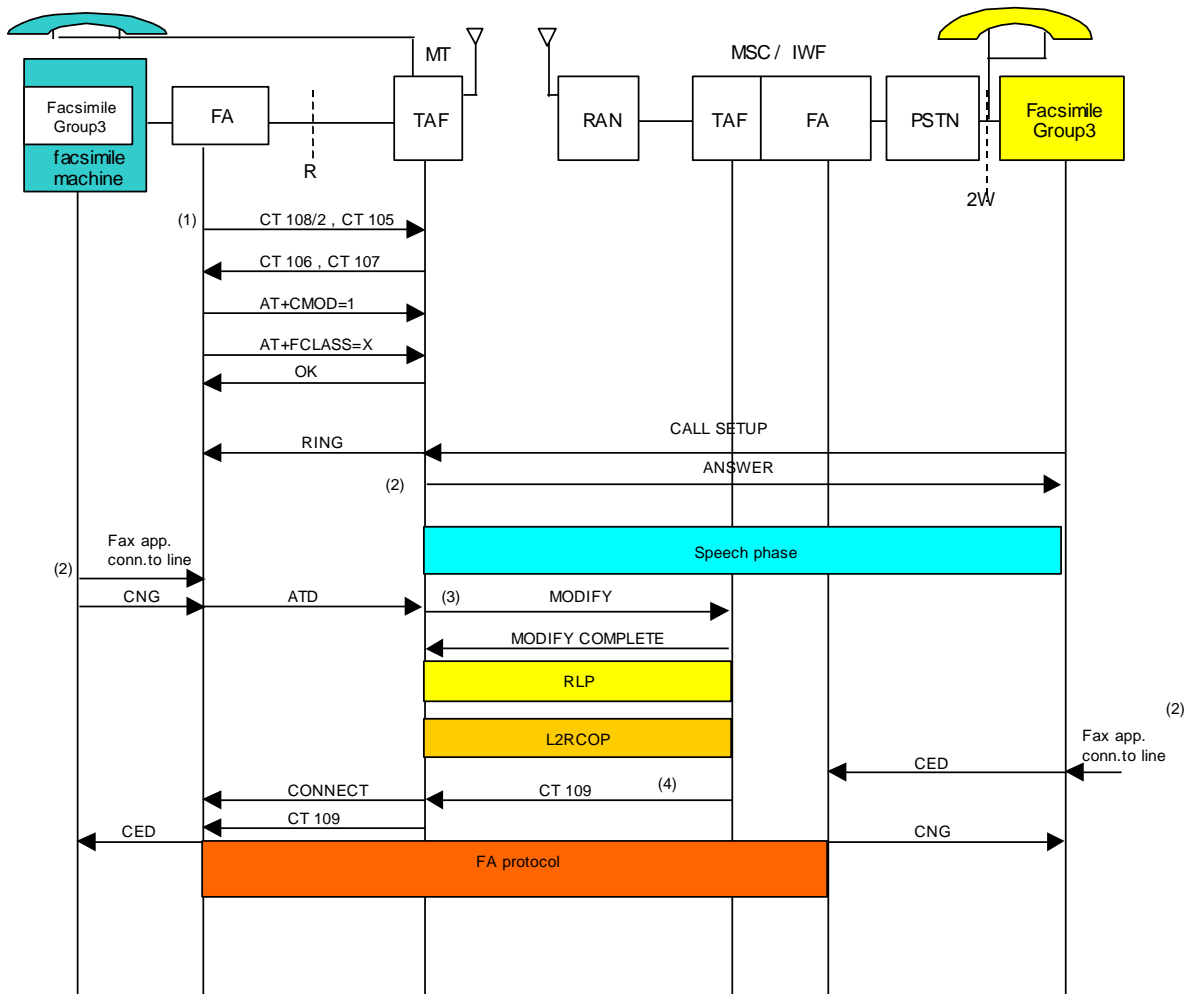

105, 106, 107, 108/2, 109: circuits according to ITU-T Recommendation V.24

- (1) speech/fax call setting
- (2) manual intervention
- (3) triggered by ATD
- (4) locally generated by the IWF

Figure C.1b: Mobile terminated call - speech then facsimile DCD mobile originated

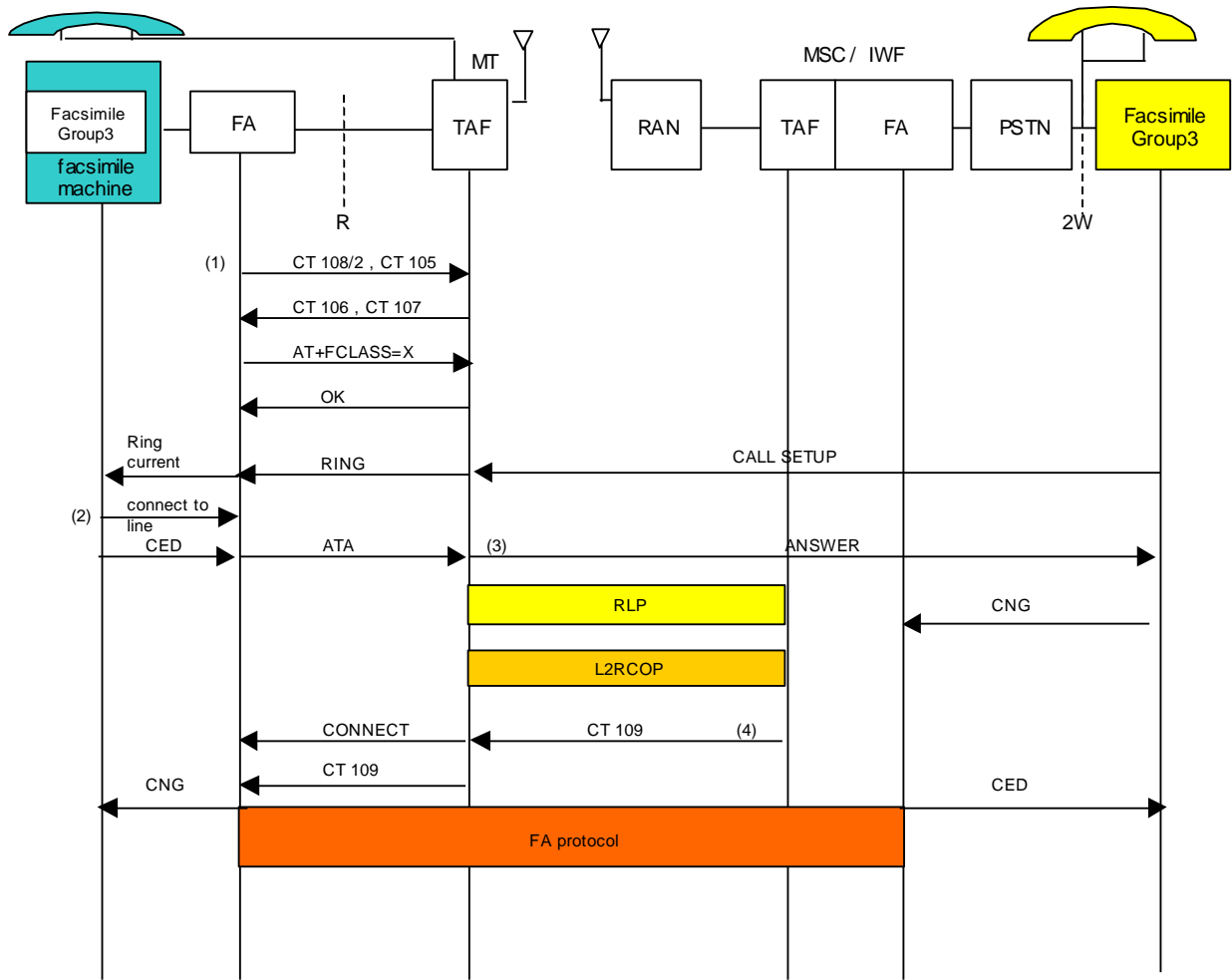

105, 106, 107, 108/2, 109: circuits according to ITU-T Recommendation V.24

- (1) fax call setting
- (2) manual or automatic operation
- (3) triggered by ATA
- (4) locally generated by the IWF

Figure C.2: Mobile terminated call - auto answer

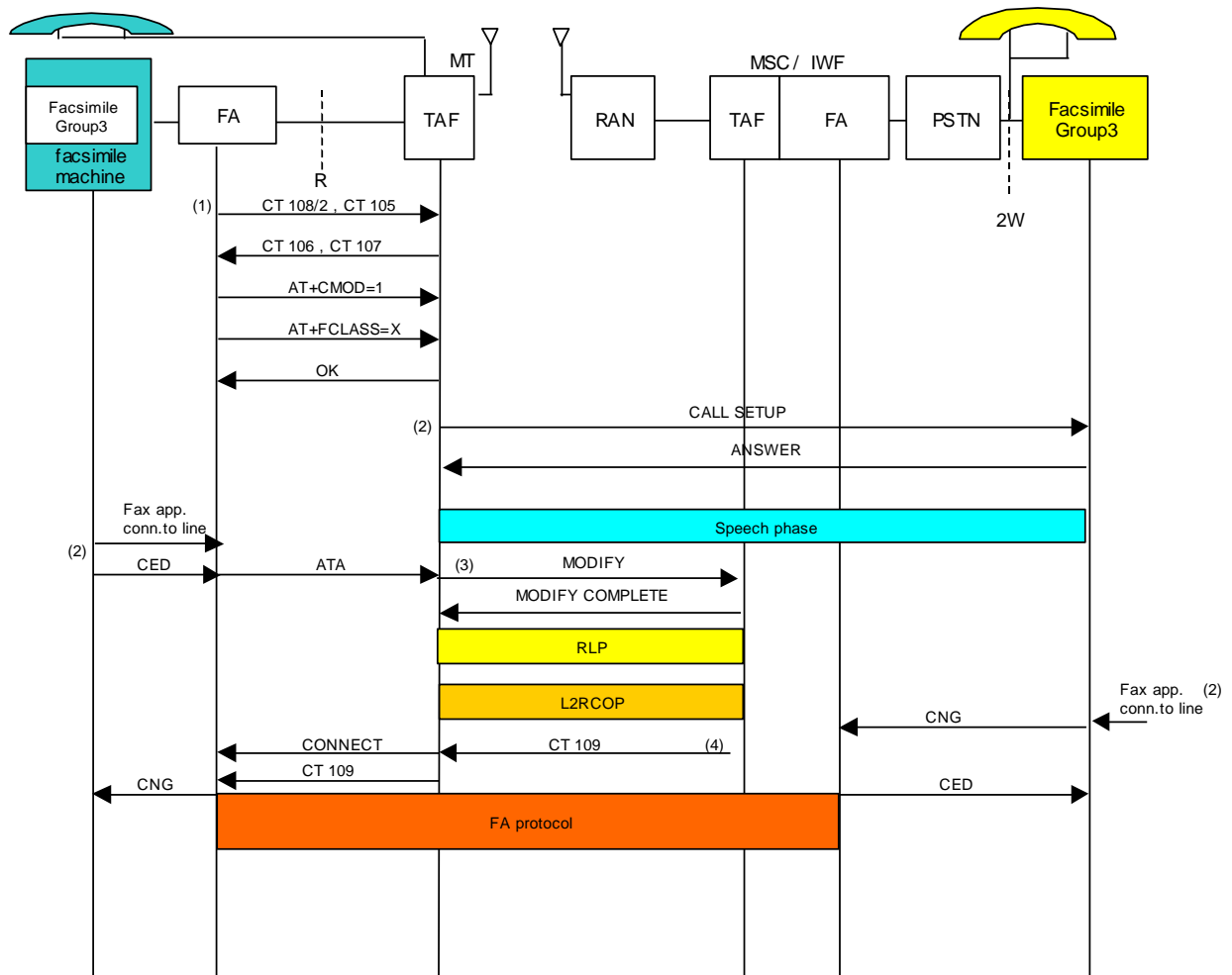

- 105, 106, 107, 108/2, 109: circuits according to ITU-T Recommendation V.24
- (1) speech/fax call setting
- (2) manual intervention
- (3) triggered by ATA
- (4) locally generated by the IWF

Figure C.3a: Mobile originated call - speech then facsimile DCD mobile terminated

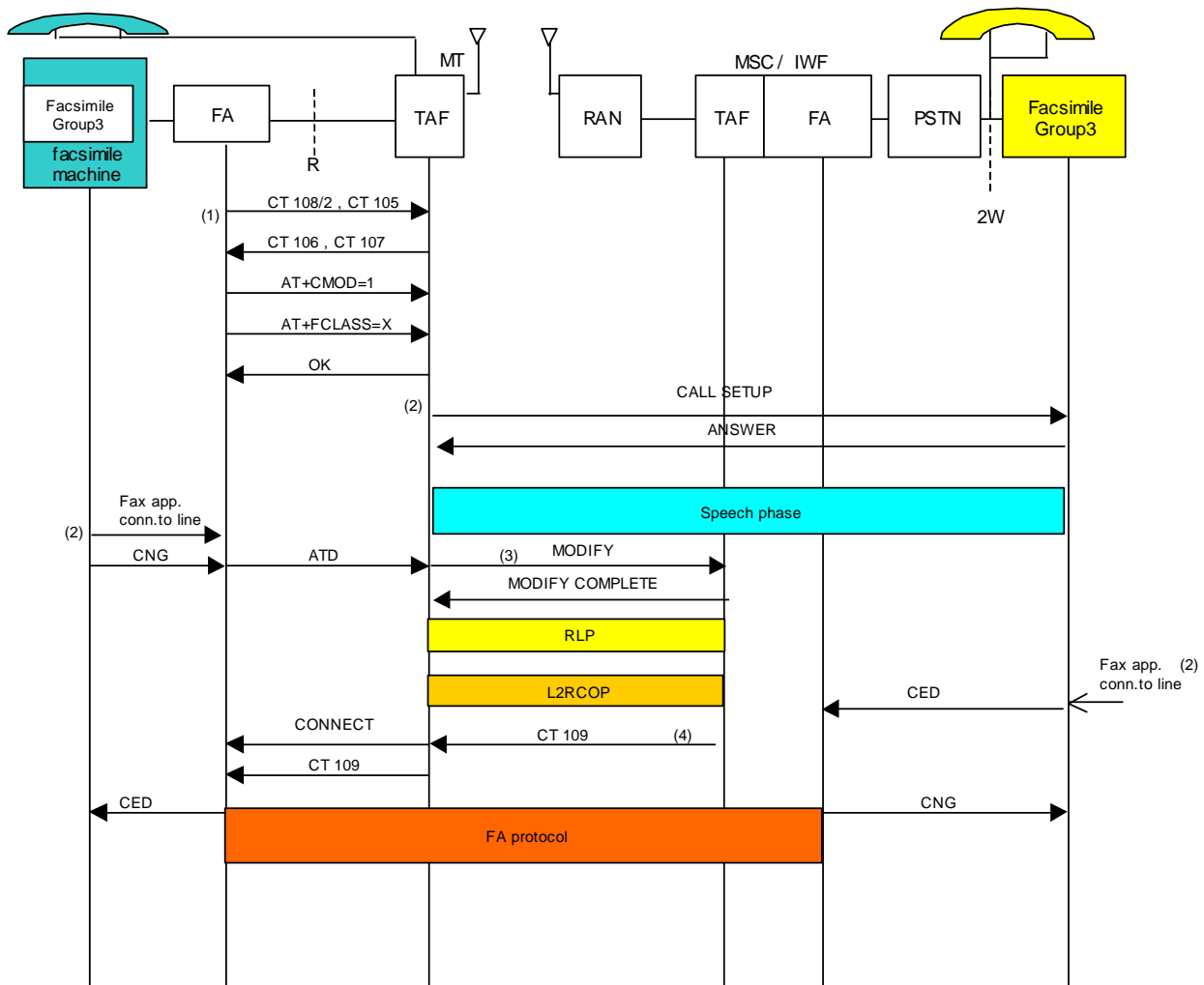

- 105, 106, 107, 108/2, 109: circuits according to ITU-T Recommendation V.24
 (1) speech/fax call setting
 (2) manual intervention
 (3) triggered by ATD
 (4) locally generated by the IWF

Figure C.3b: Mobile originated call - speech then facsimile DCD mobile originated

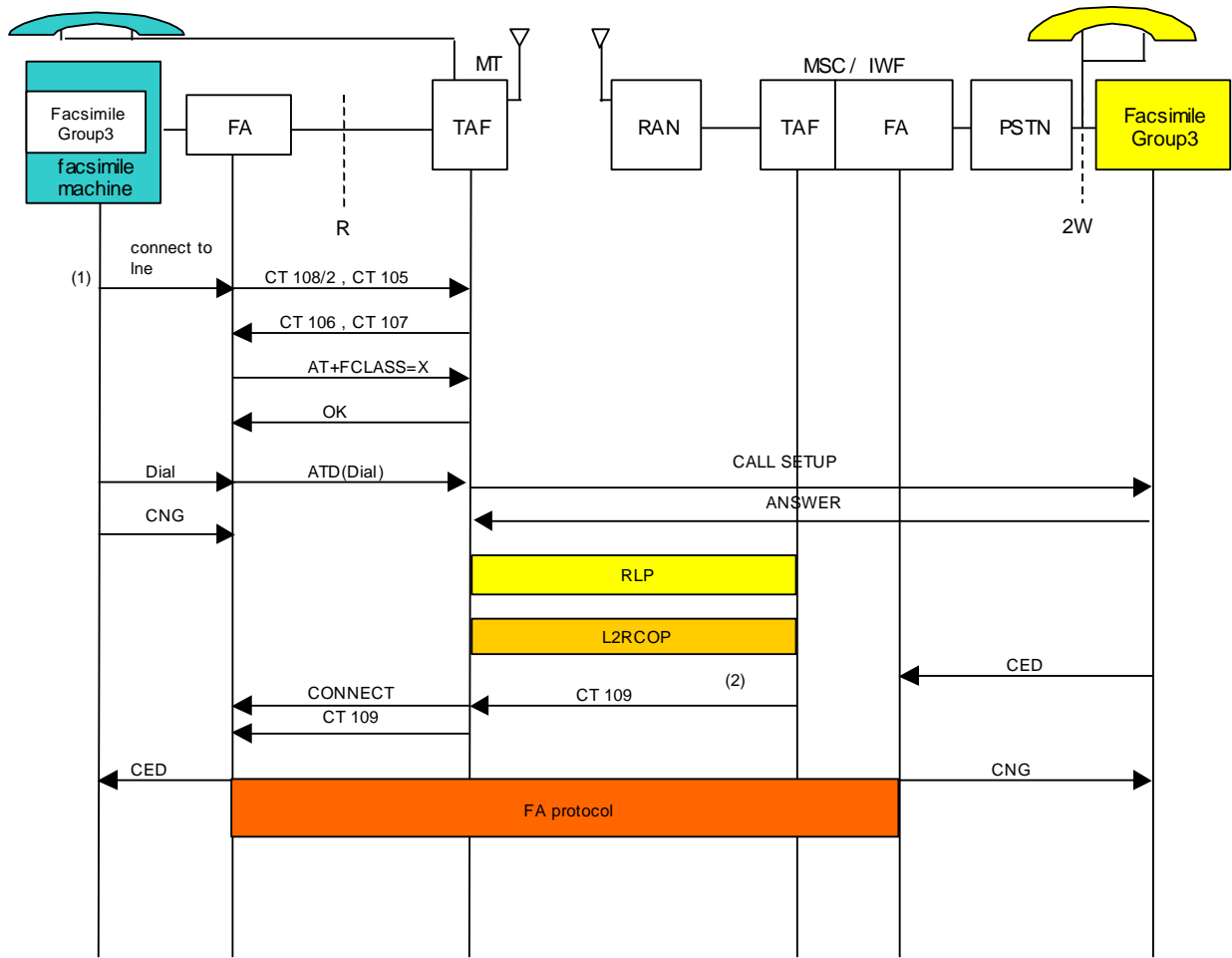

105, 106, 107, 108/2, 109: circuits according to ITU-T Recommendation V.24

- (1) manual intervention
- (2) locally generated by the IWF

Figure C.4: Mobile originated call - auto calling

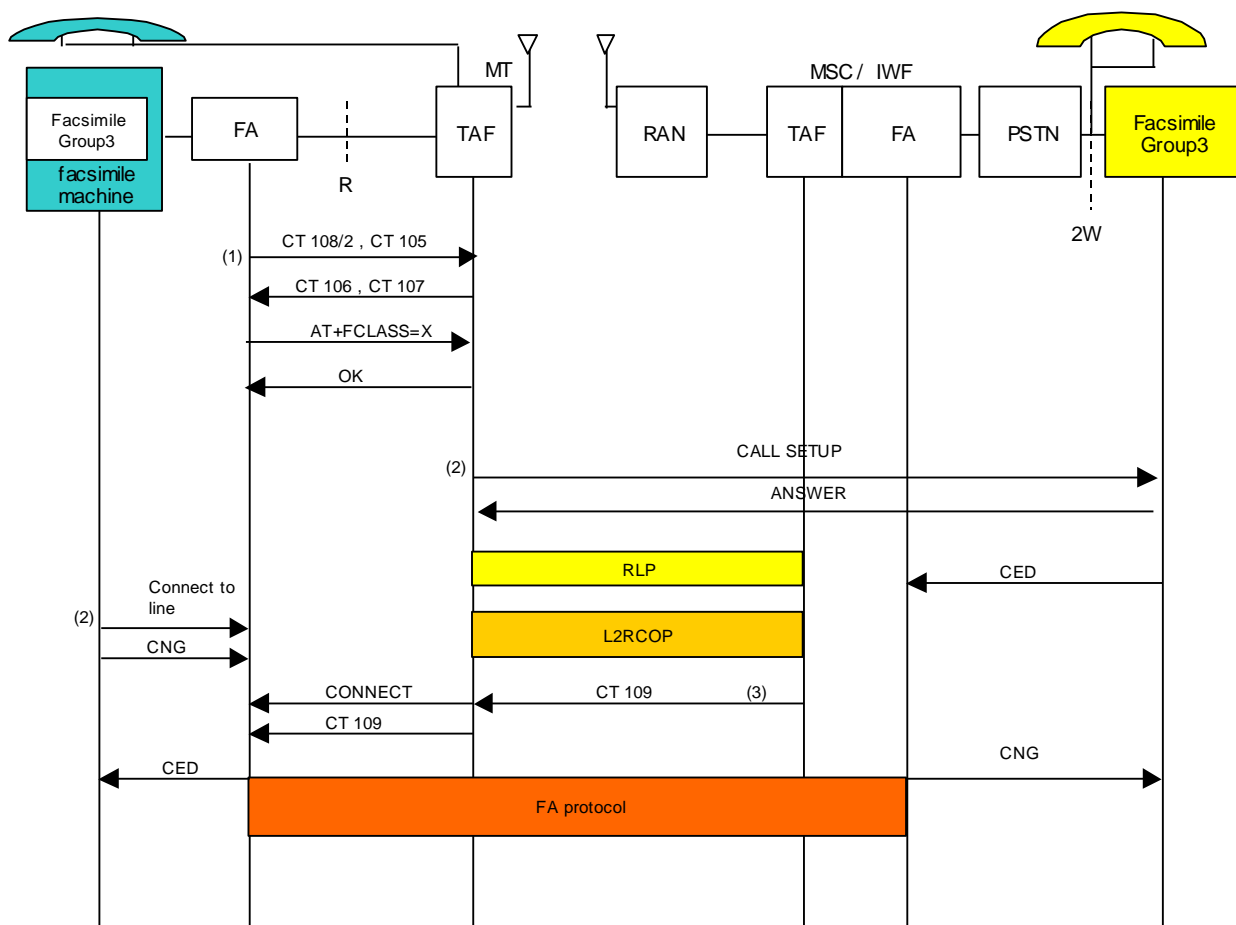

105, 106, 107, 108/2, 109: circuits according to ITU-T Recommendation V.24

- (1) fax call setting
- (2) manual intervention
- (3) locally generated by the IWF

Figure C.5: Mobile originated call - manual calling

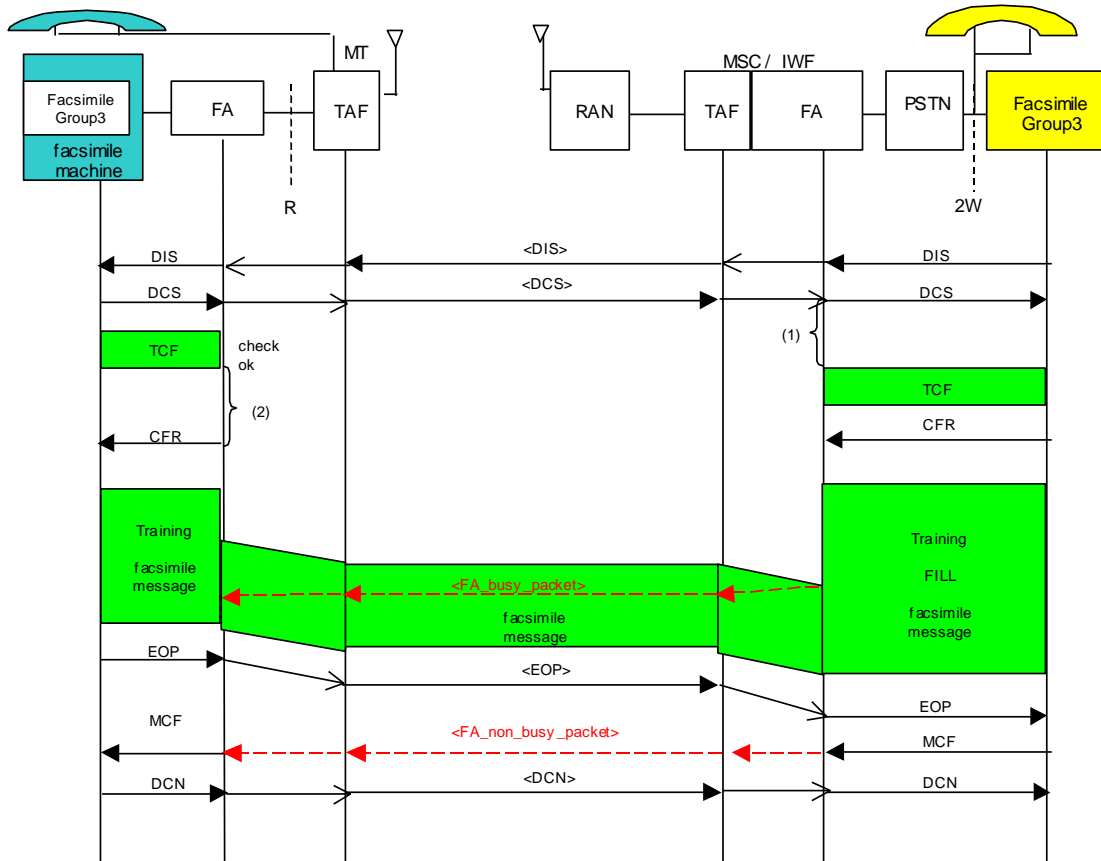

- (1) triggered by delayed DCS(75 ms)
- (2) triggered by delayed TCF(2,4 s)

Figure C.6: Mobile originated facsimile transmission

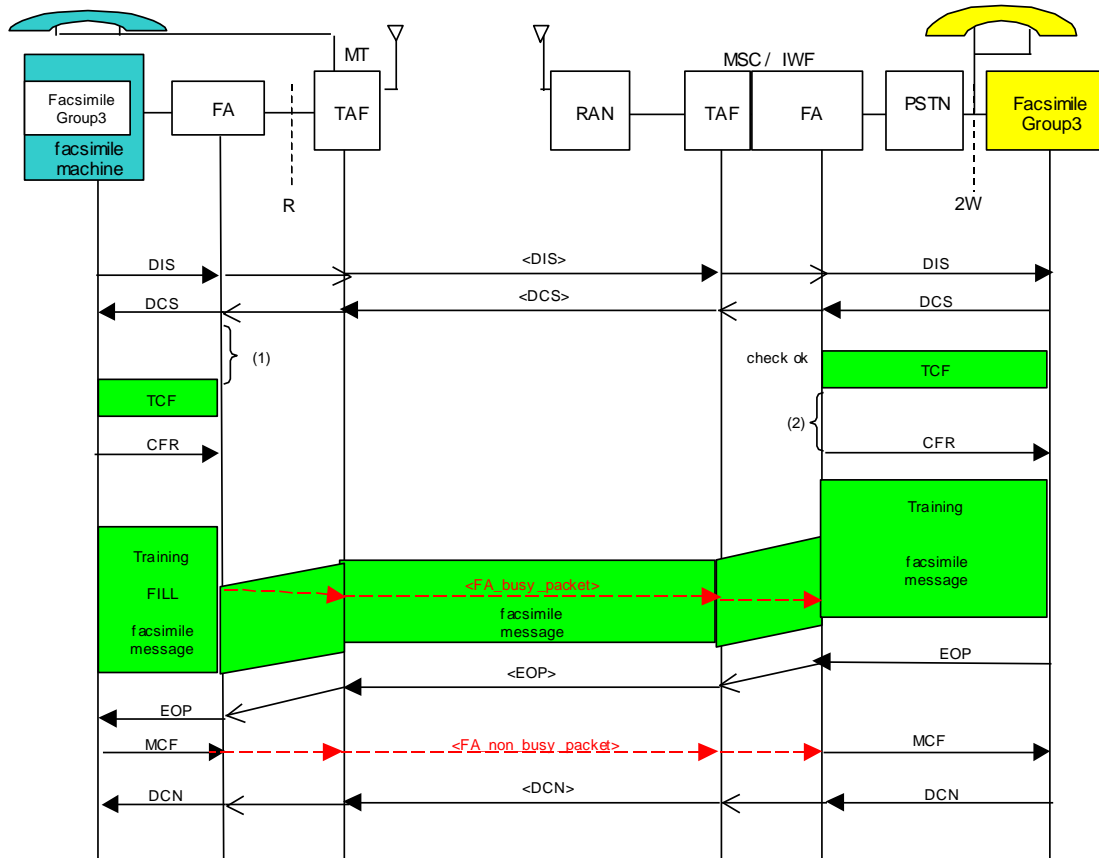

- (1) triggered by delayed DCS(75 ms)
- (2) triggered by delayed TCF(2,4 s)

Figure C.7: Mobile terminated facsimile transmission

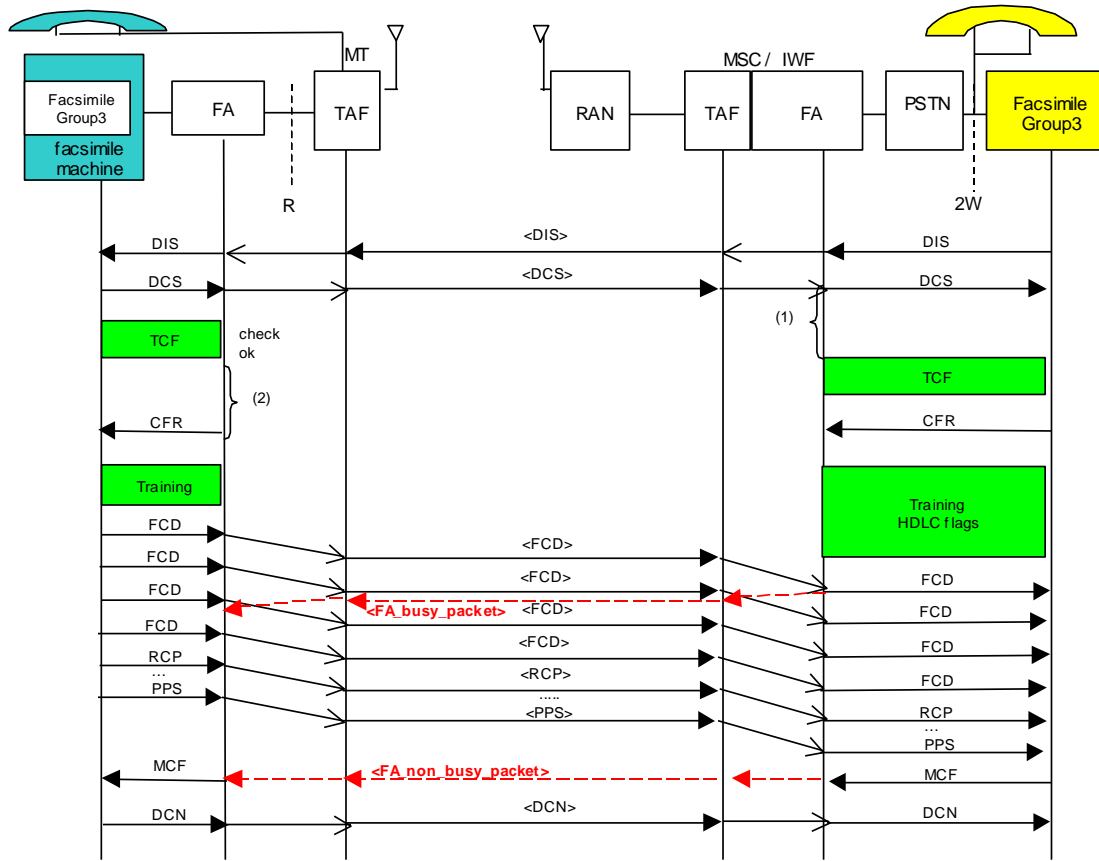

- (1) triggered by delayed DCS(75 ms)
- (2) triggered by delayed TCF(2,4 s)

Figure C.8: Mobile originated facsimile transmission (error correction mode)

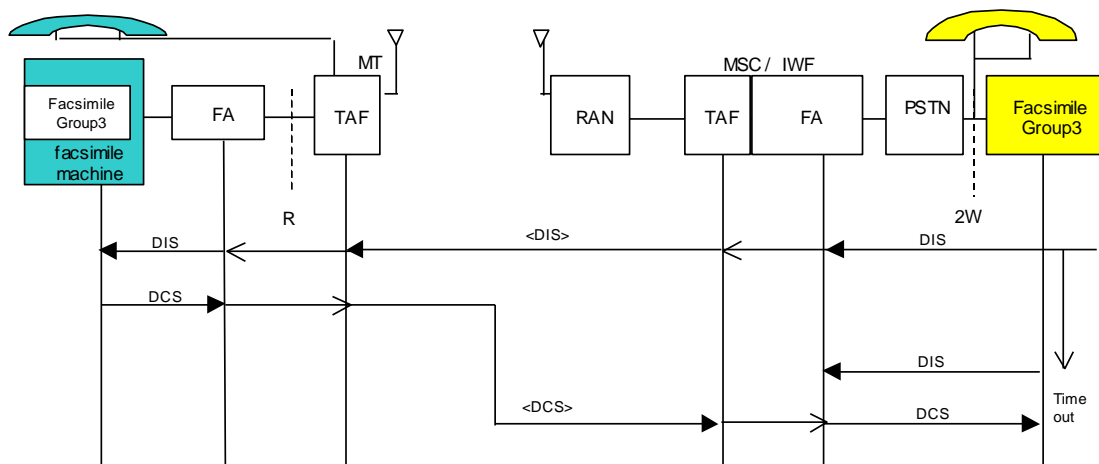

Figure C.9: Mobile originated facsimile transmission - error recovery (example)

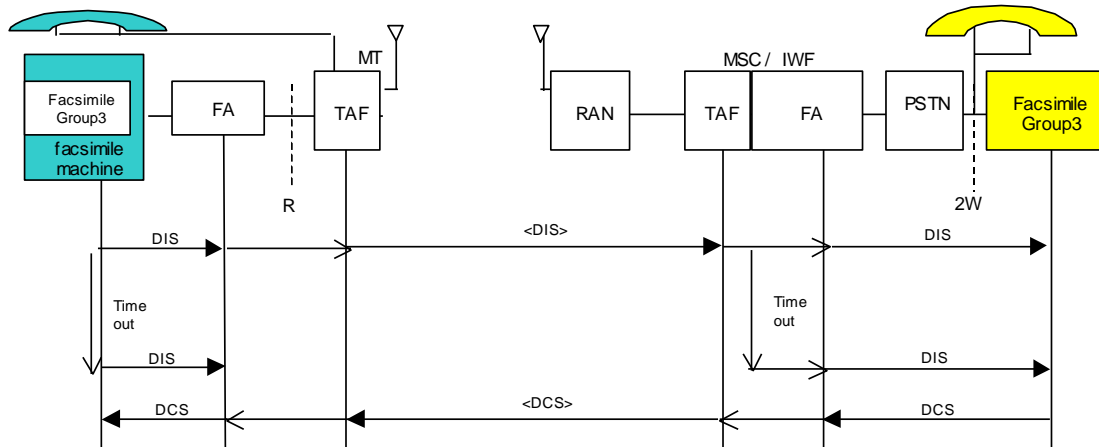
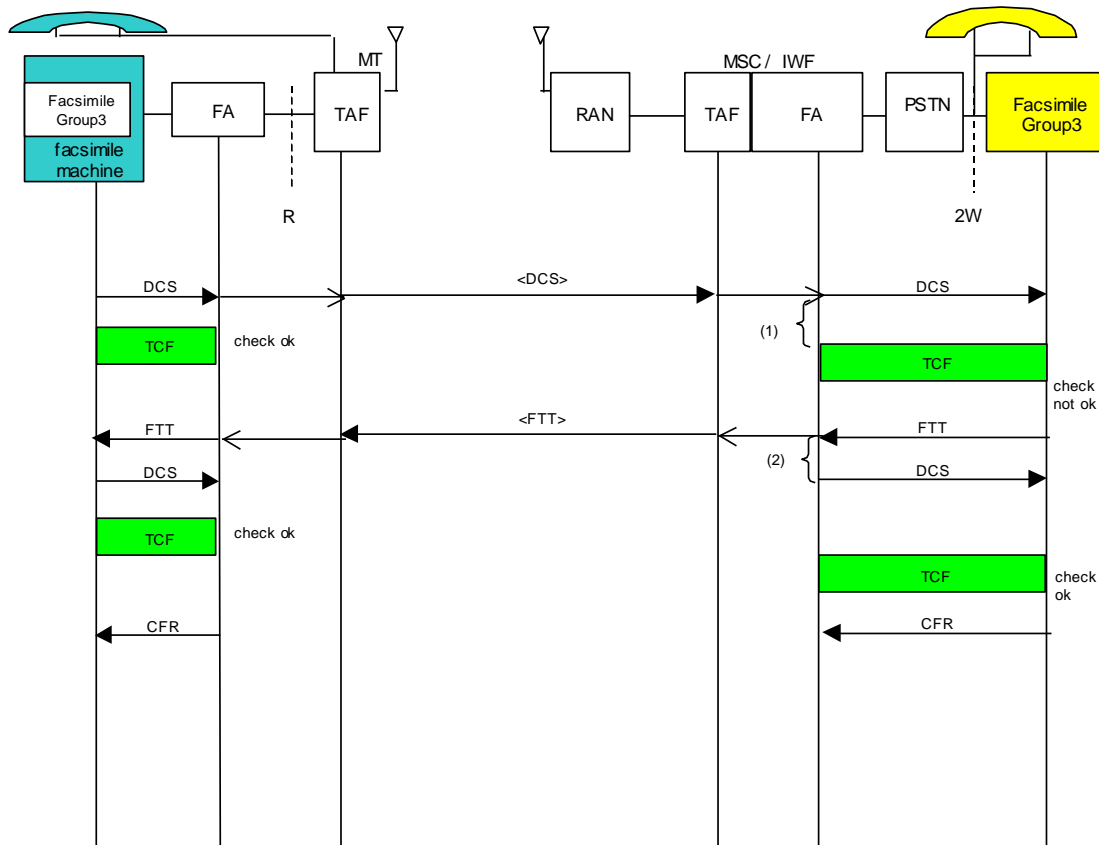
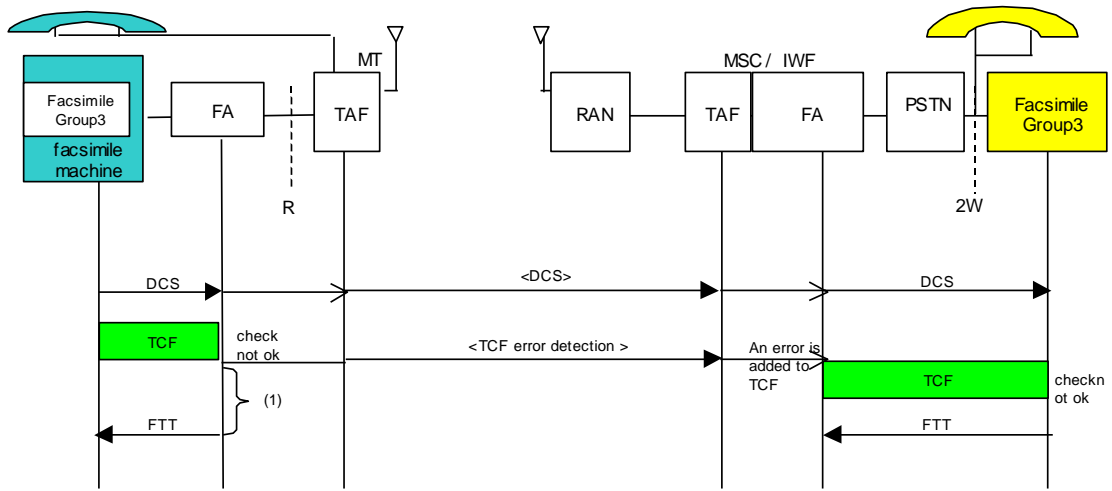

Figure C.10: Mobile terminated facsimile transmission - error recovery (example)



- (1) triggered by delayed DCS(75 ms)
- (2) triggered by delayed FTT(75 ms)

Figure C.11: Mobile originated facsimile transmission - error recovery (example)



(1) triggered by delayed TCF error detection element (2,4 s)

Figure C.12: Mobile originated facsimile transmission - error recovery (example)

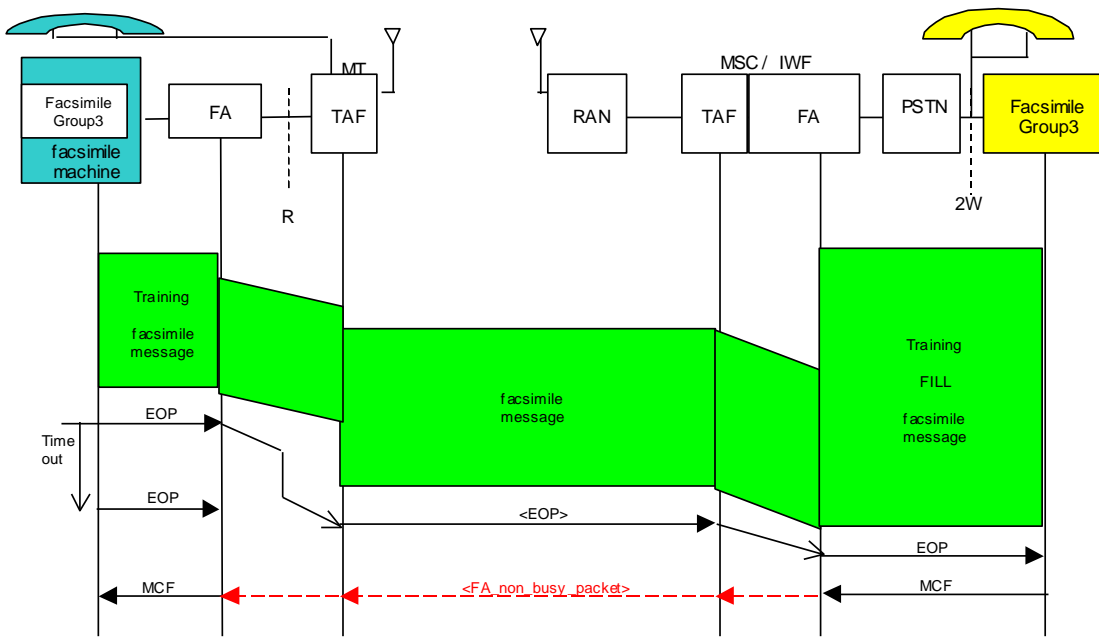

Figure C.13: Mobile originated facsimile transmission - error recovery (example)

Annex D (normative): SDL Diagrams

The SDL specification within this Appendix shall be used as a reference model for implementation. The external behaviour of an implementation shall comply with the present document. However internal behaviour may be implementation dependent.

Table D.1: State symbols

State symbol	Phase / Mode		
A	Phase A	Transmission / Reception side FA	NONECM/ ECM
R-A1		Reception side FA	
T	Phase B	Transmission side FA	NONECM/ ECM
T_B1			
T_B2			
T_B4			
T_B5			
R		Reception side FA	
R_B1			
R_B3			
R_B4			
R_B5			
T_C1	Phase C	Transmission side FA	NONECM
T_C2			ECM
R_C1		Reception side FA	NONECM
R_C2			ECM
T_D1	Phase D	Transmission side FA	NONECM
T_D2			ECM
T_D2_res1			
T_D2_res2			
R_D1		Reception side FA	NONECM
R_D2			ECM
R_D1_MPS			NONECM
R_D1_EOM			
R_D1_EOP			
R_D2_NULL			ECM
R_D2_MPS			
R_D2_EOM			
R_D2_EOP			
R_D2_E_NULL			
R_D2_E_MPS			
R_D2_E_EOM			
R_D2_E_EOP			
E1	Phase E	Transmission / Reception side FA	NONECM/ ECM
E2			
E3			

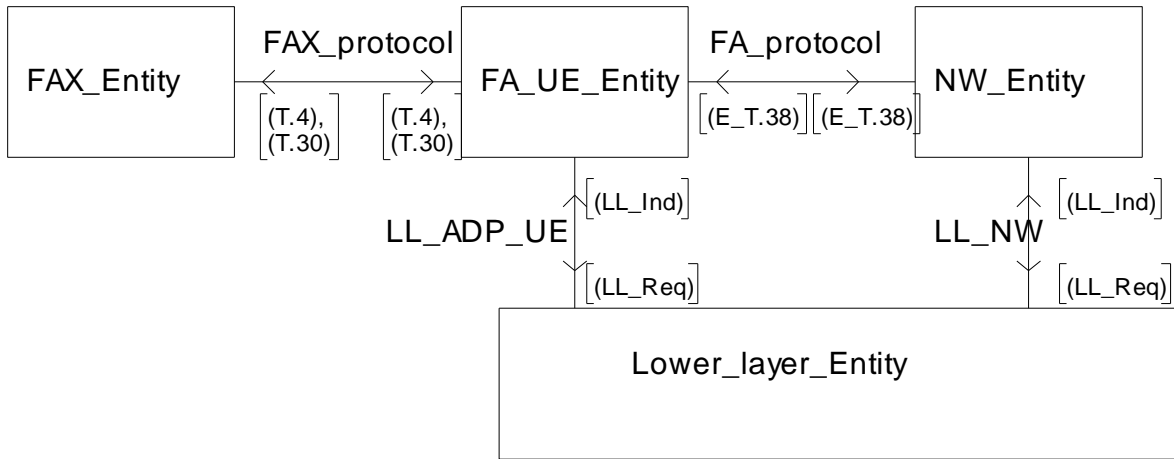
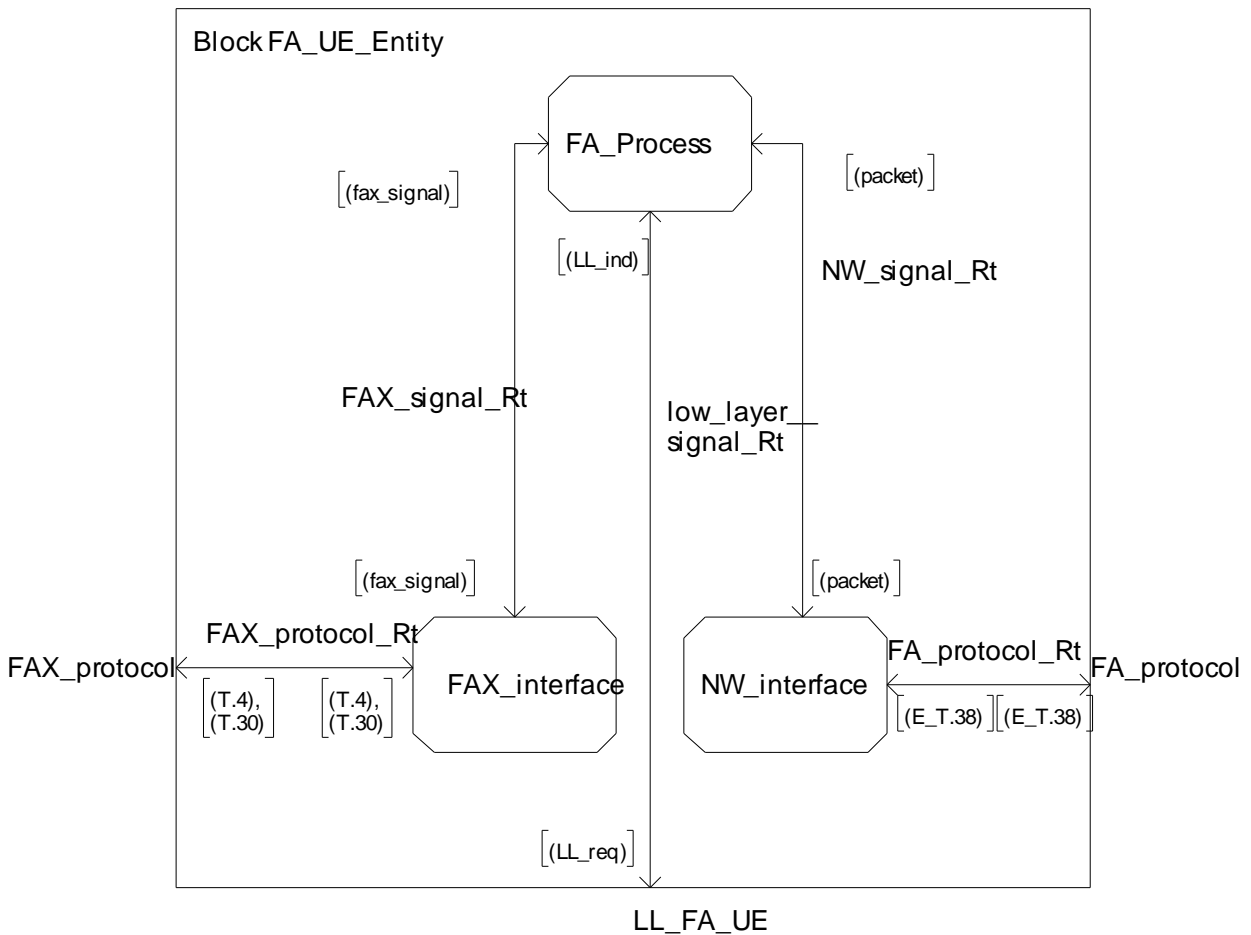

Figure D.1: System 23.146 - Overview



```

signallist fax_signal =
CED,
CFR,
CIG.DTC,
CNG,
CSI.DIS,
CSI.DIS.NSF,
CTC,
CTR,
EOM,
EOP,
EOR_EOM,
EOR_EOP,
EOR_MPS,
EOR_NULL,
ERR,
FCD,
FTT,
MCF,
MPS,
PIX,
PIX.RCP,
PIX.RTC,
PPR,
PPS_EOM,
PPS_EOP,
PPS_MPS,
PPS_NULL,
preamble,
RCP,
RNR,
RTC,
RTN,
RTP,
TCF,
TCF_with_error,
Carrier_off;
    
```

```

signallist packet =
CED_packet,
CIG.DTC_packet,
CNG_packet,
CSI.DIS_packet,
CTC_packet,
DCN_packet,
DIS_packet,
DTC_packet,
EOL_packet,
EOM_packet,
EOP_packet,
EOR_Q_packet,
FCD_packet,
FTT_packet,
MPS_packet,
PPS_EOM_packet,
PPS_EOP_packet,
PPS_MPS_packet,
PPS_NULL_packet,
PPS_Q_packet,
TCF_error_detection_packet,
TSI.DCS_packet,
FA_busy_packet,
FA_non_busy_packet;
    
```

```

signallist LL_ind =
low_layer_established;
    
```

```

signallist LL_req =
low_layer_Disconnect;
    
```

Figure D.2a: Block FA_UE Entity

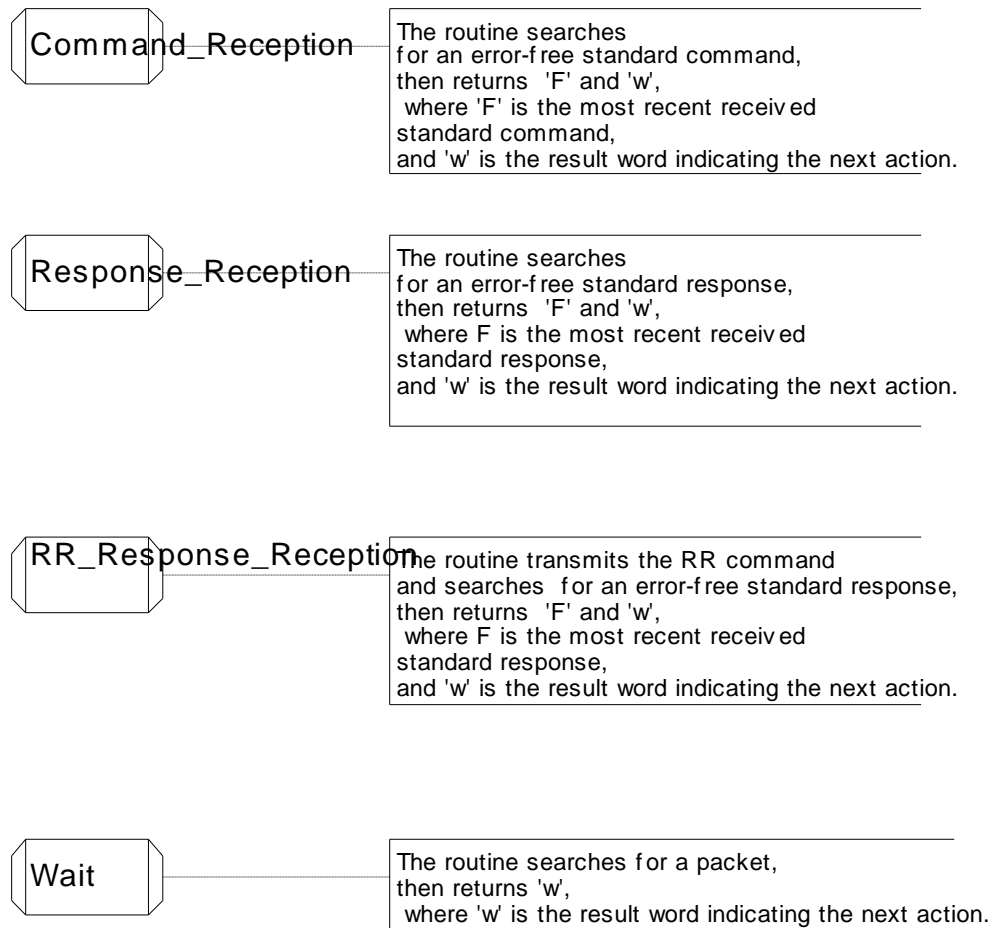

Figure D.2b: Procedure Reference

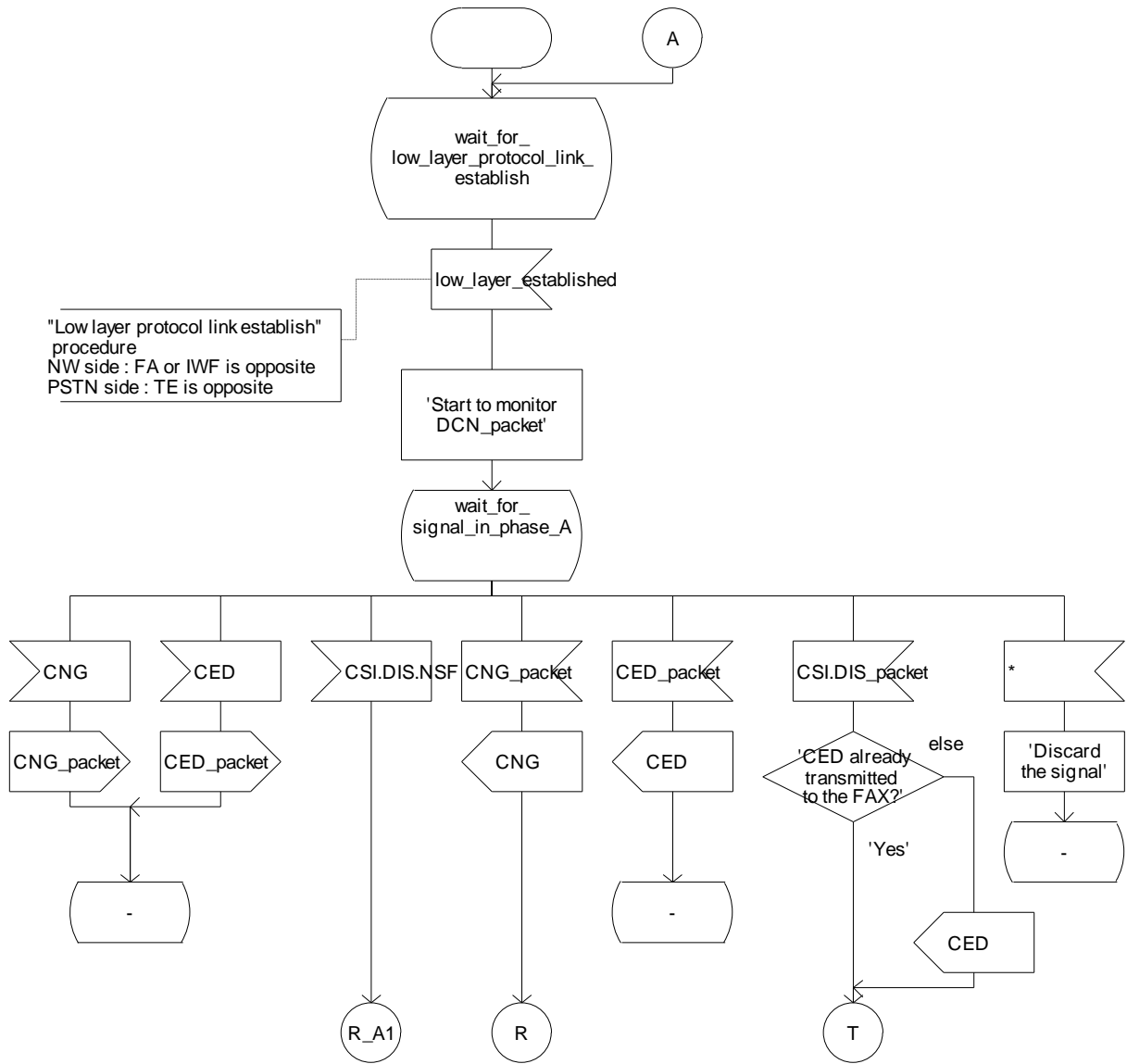

Figure D.3: Initial operation flow for a FA (Analogue)

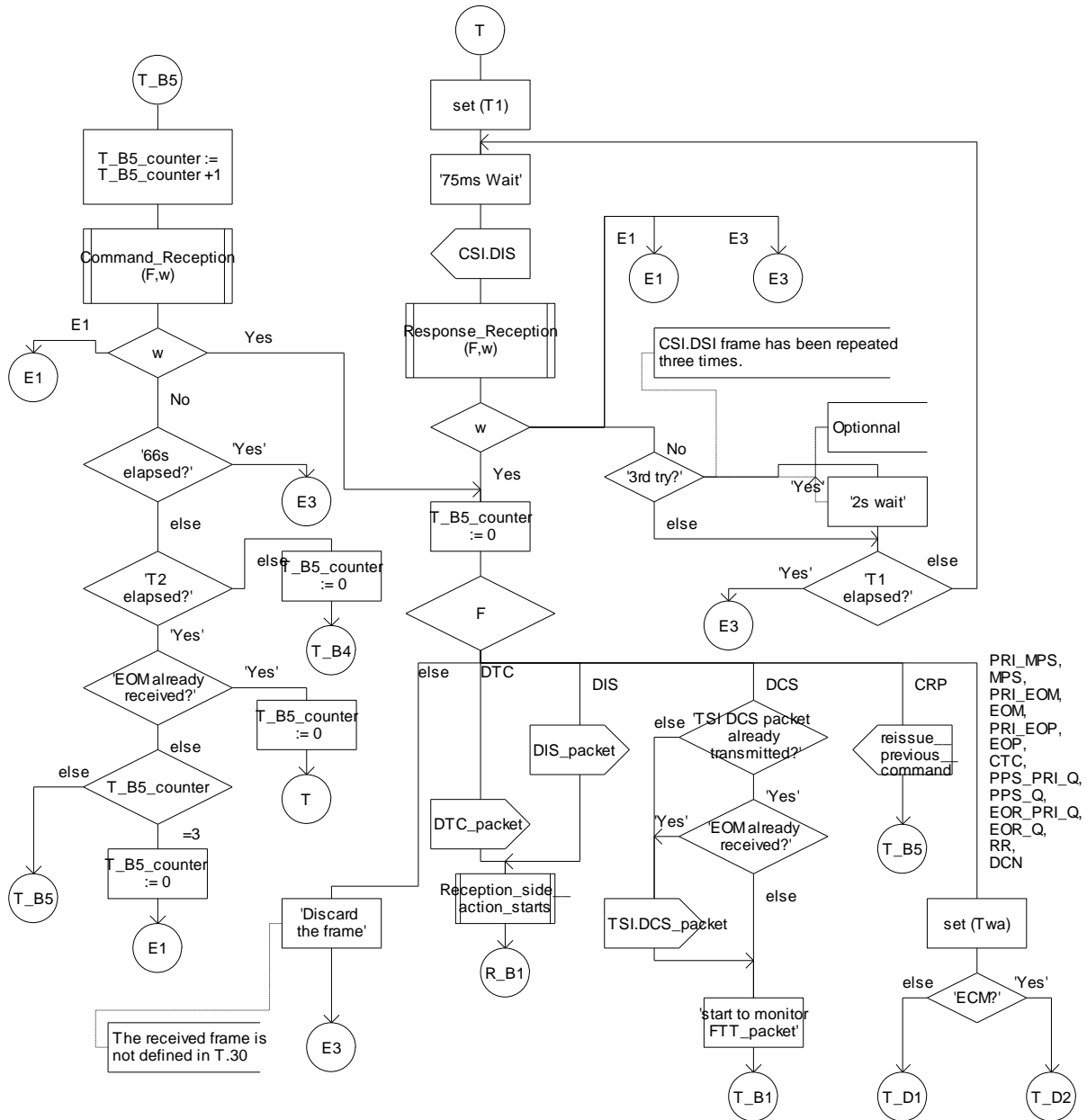

Figure D.4: Transmission side FA, Phase B (Basic control flow)

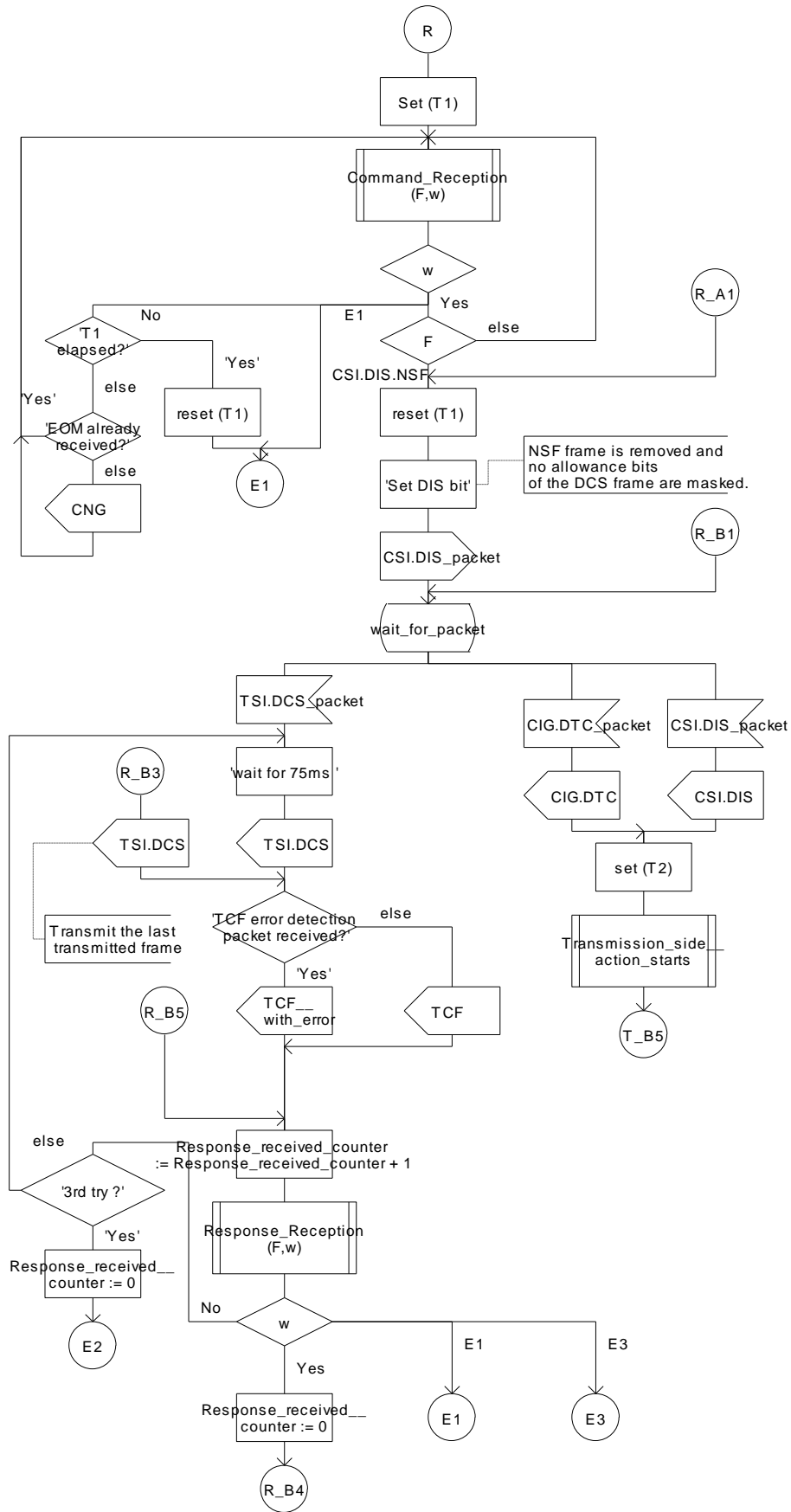

Figure D.5: Reception side FA, Phase B

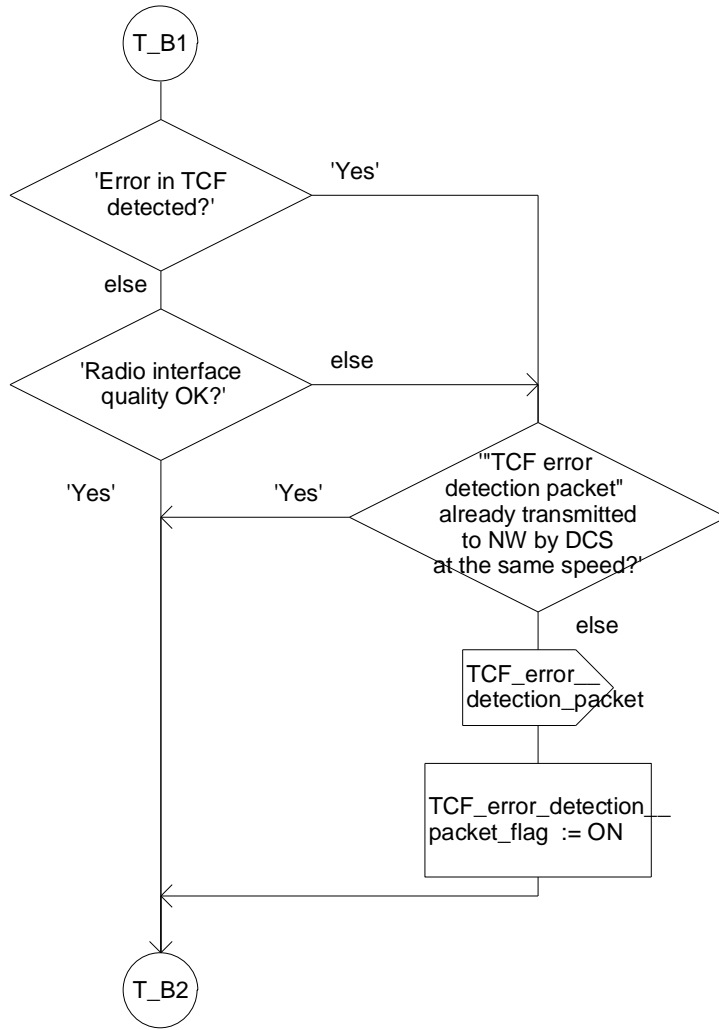

Figure D.6: Output conditions for "TCF error detection" for ECM&NONECM

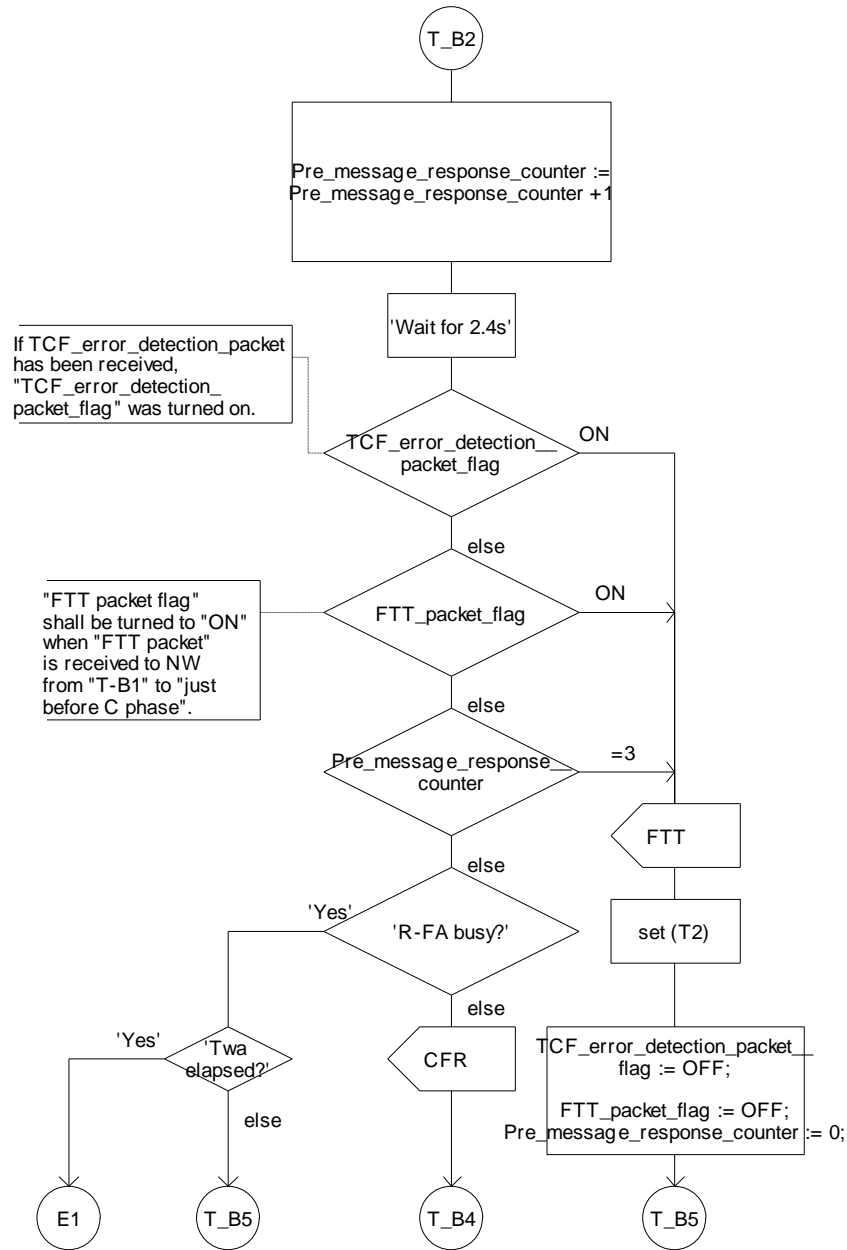

Figure D.7: Selection algorithm for CFR /FTT for T-FA ECM & NONECM

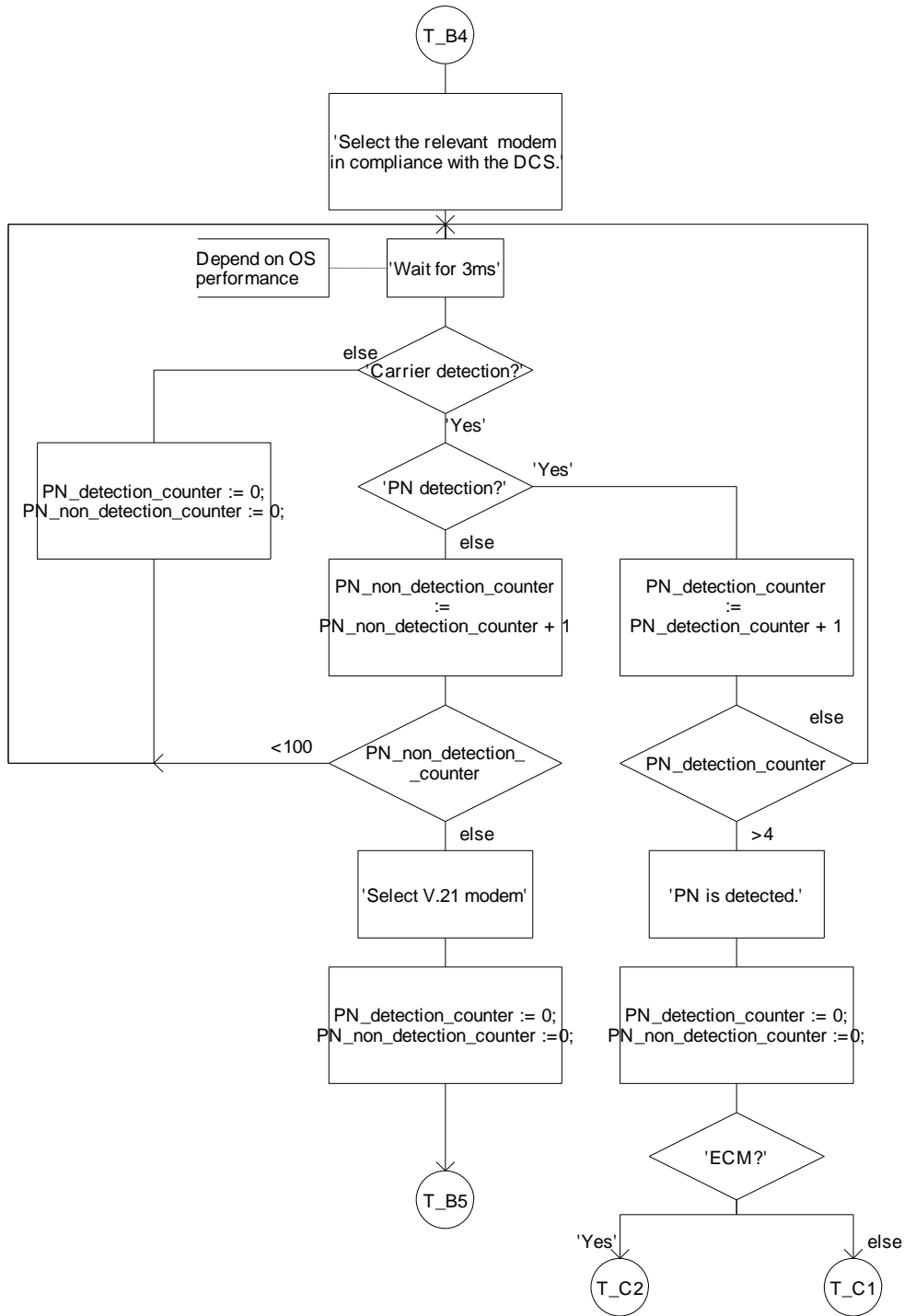

Figure D.8: Stand-by method for V.21/V.17/V.27ter/V.29 for T-FA

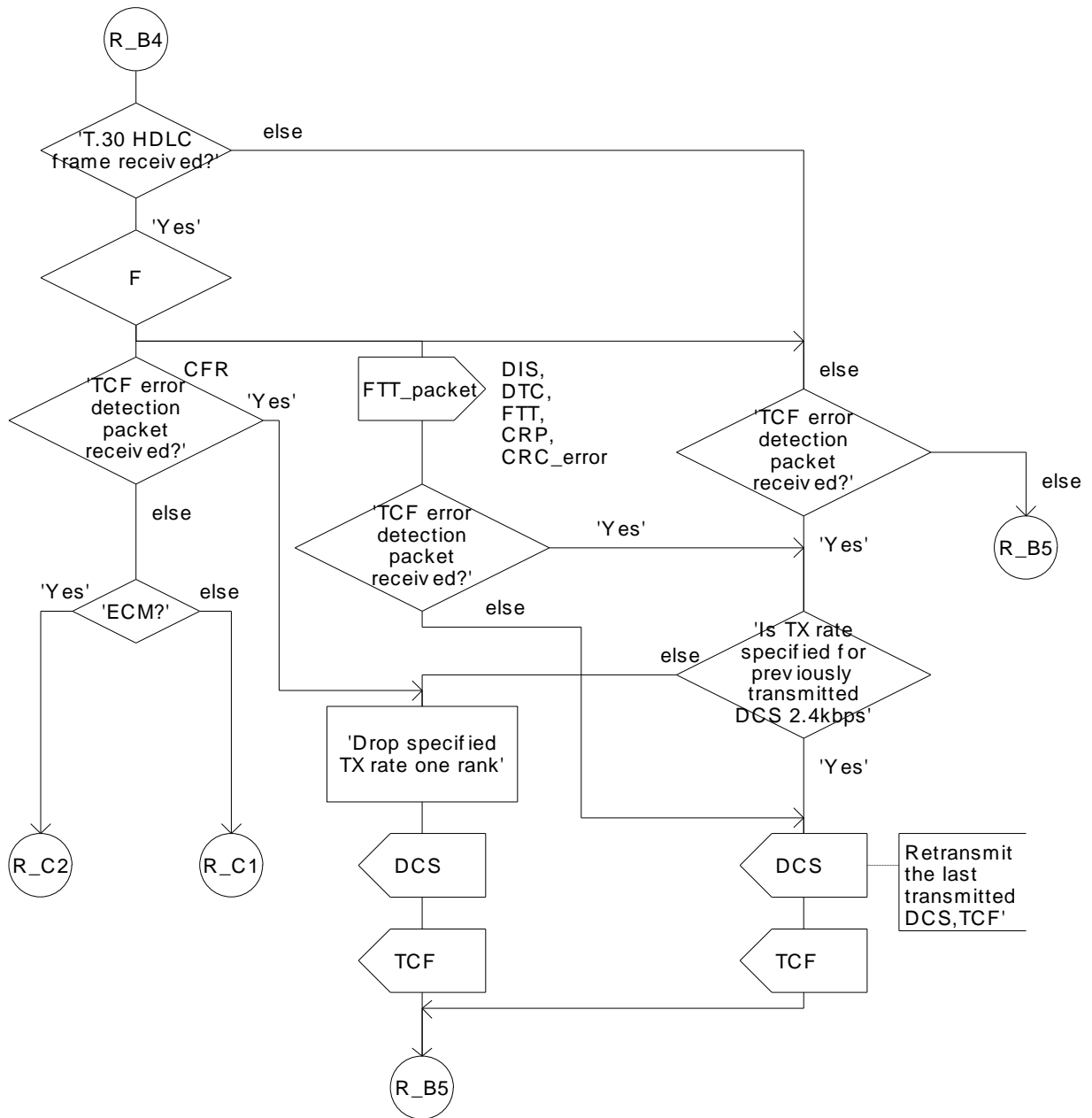

Figure D.9: Output conditions for FTT and specified TX rate decision algorithm for DCS NONECM & ECM

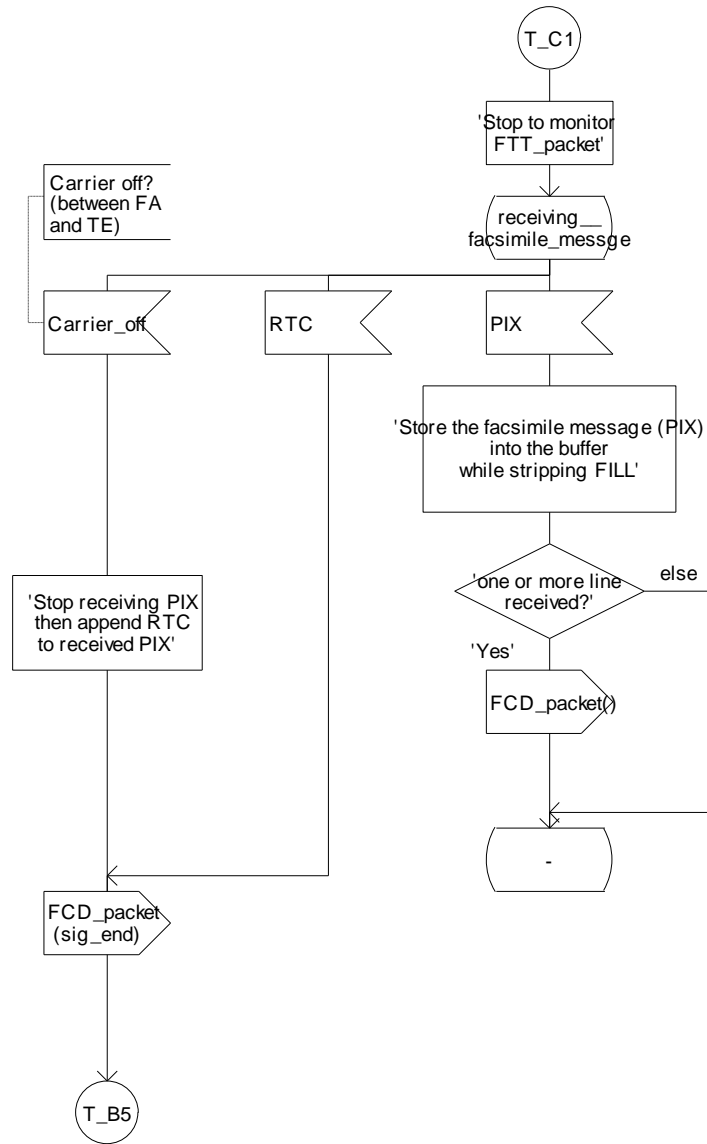

Figure D.10: Transmission side FA, Phase C for NONECM

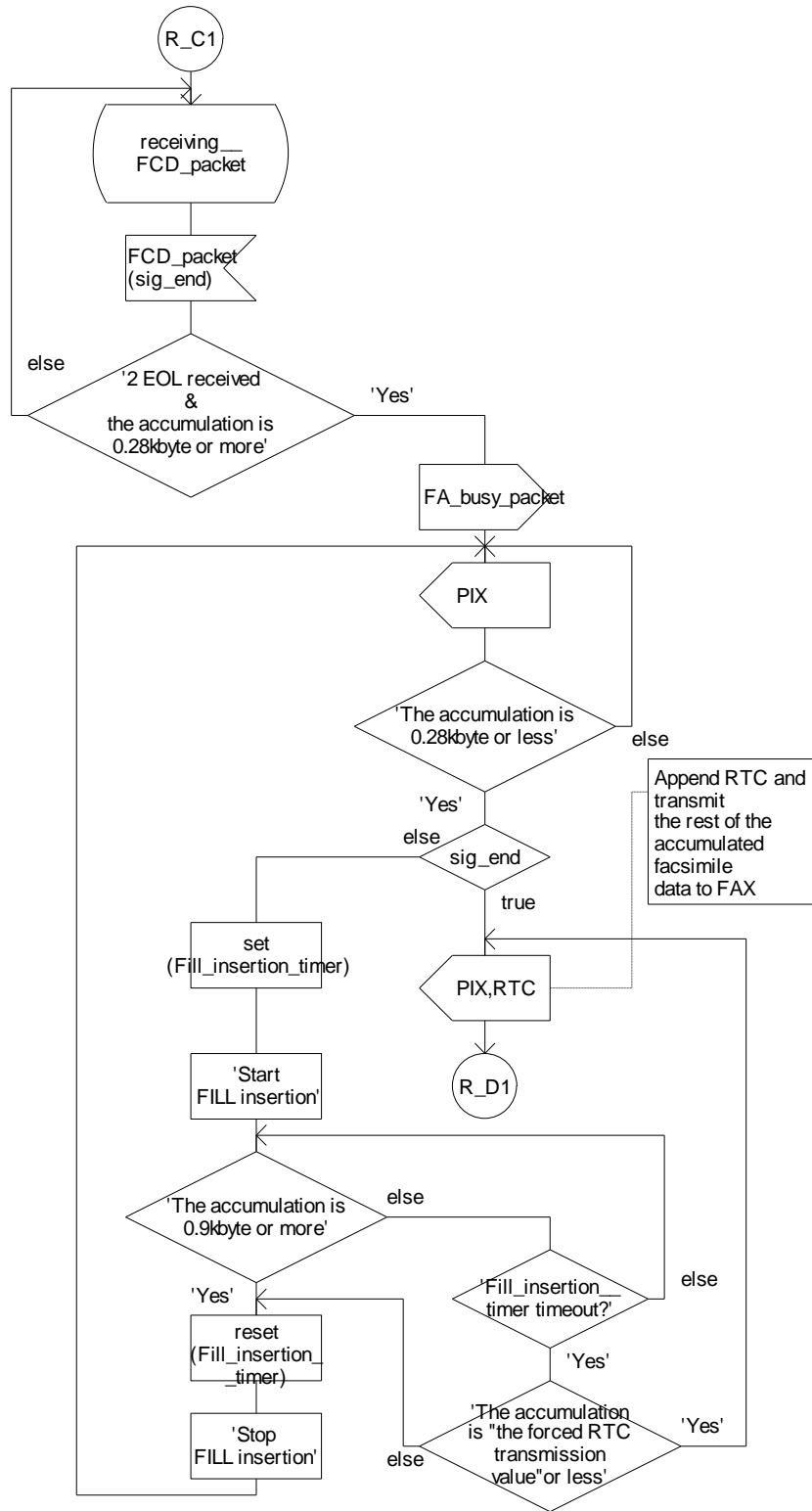

Figure D.11: Reception side FA, phase C for NONECM

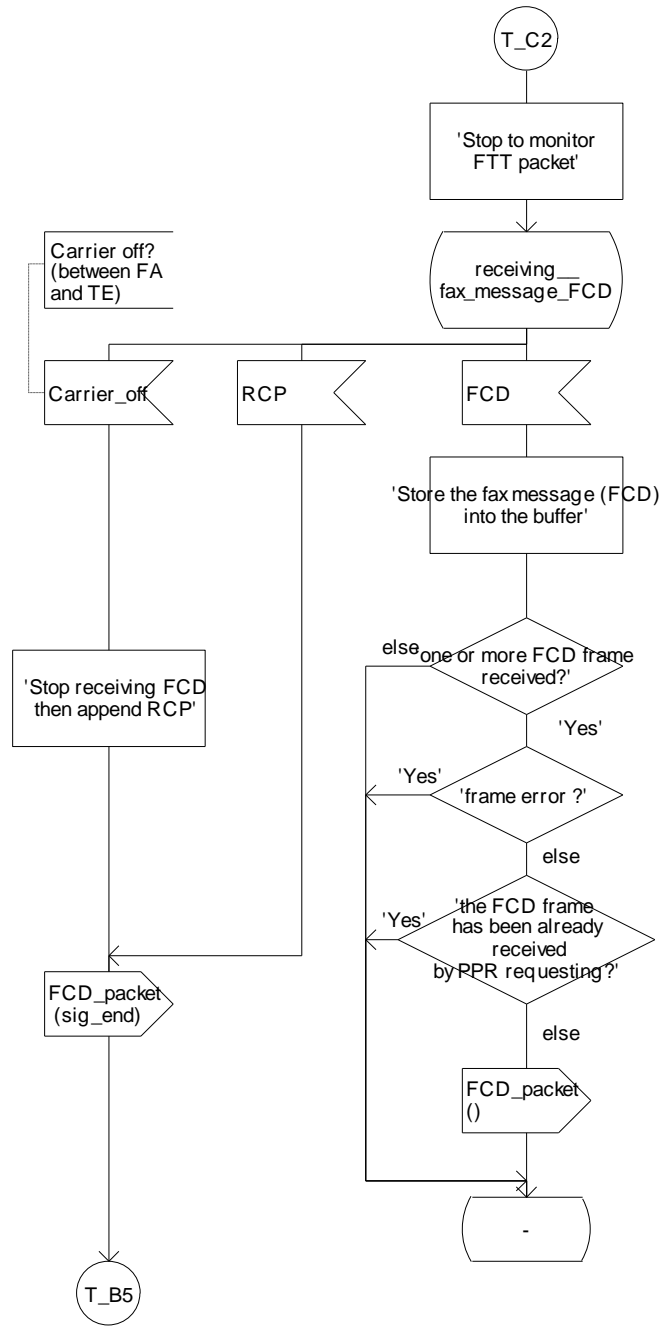

Figure D.12: Transmission side FA, Phase C for

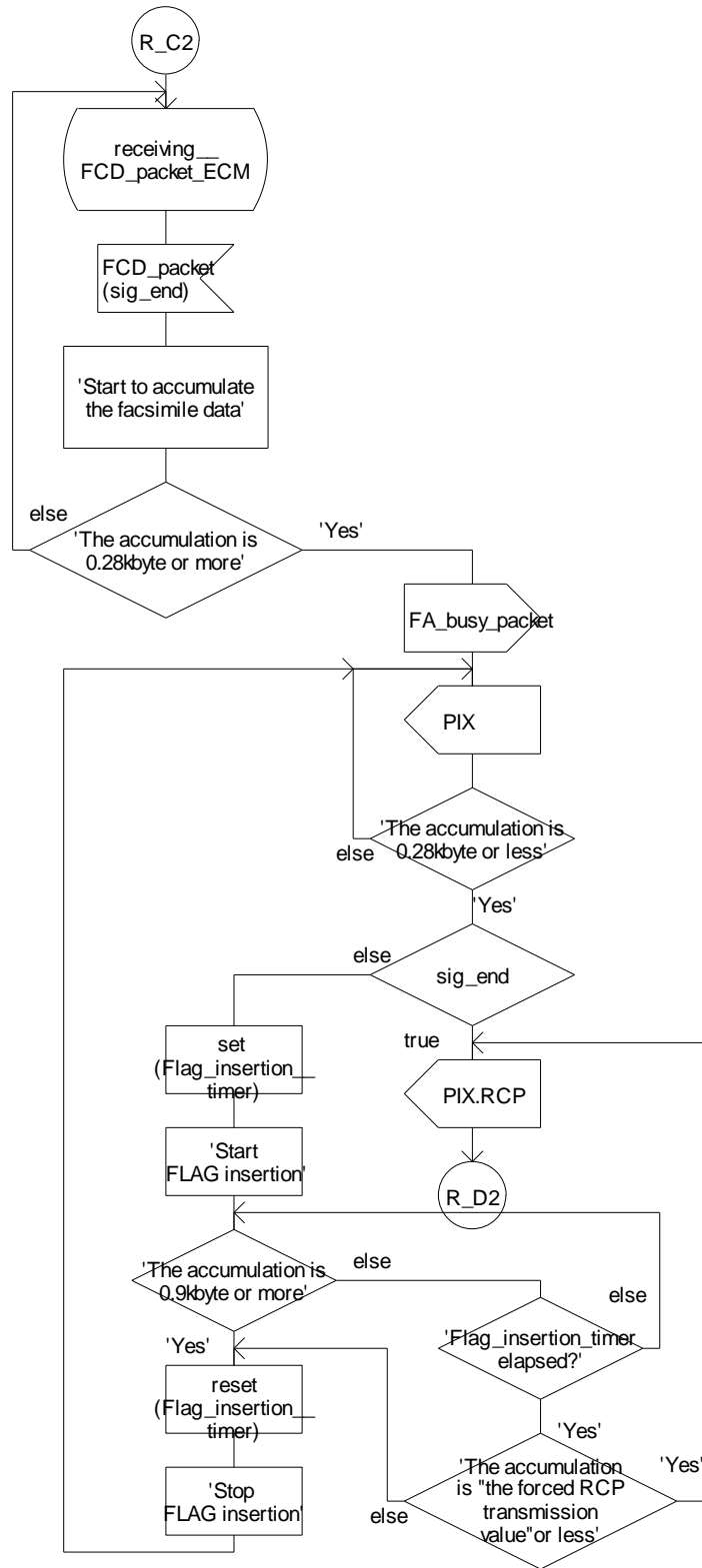

Figure D.13: Reception side FA, phase C for ECM

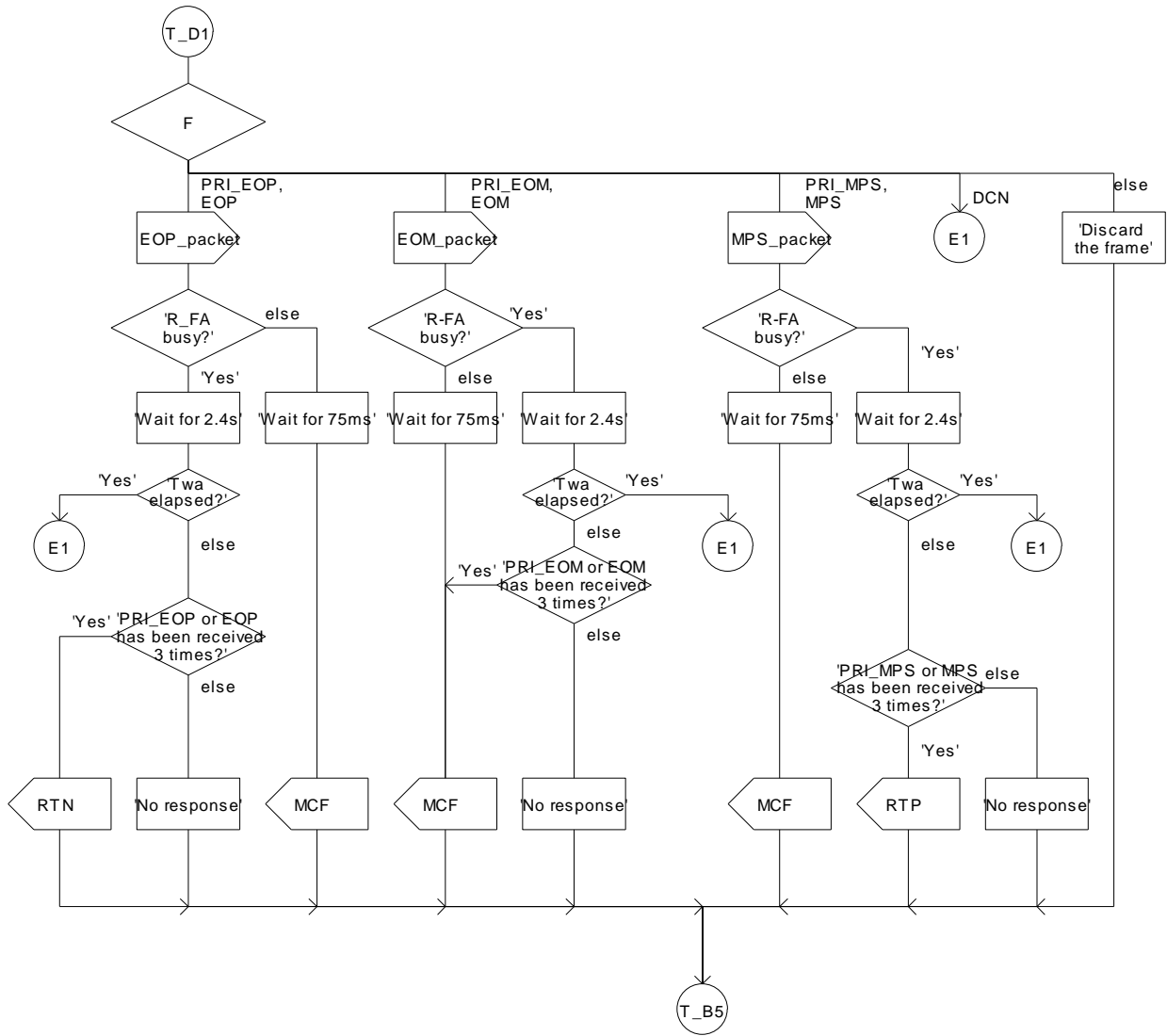

Figure D.14: Transmission side FA for NON ECM, Phase D (Basic control flow)

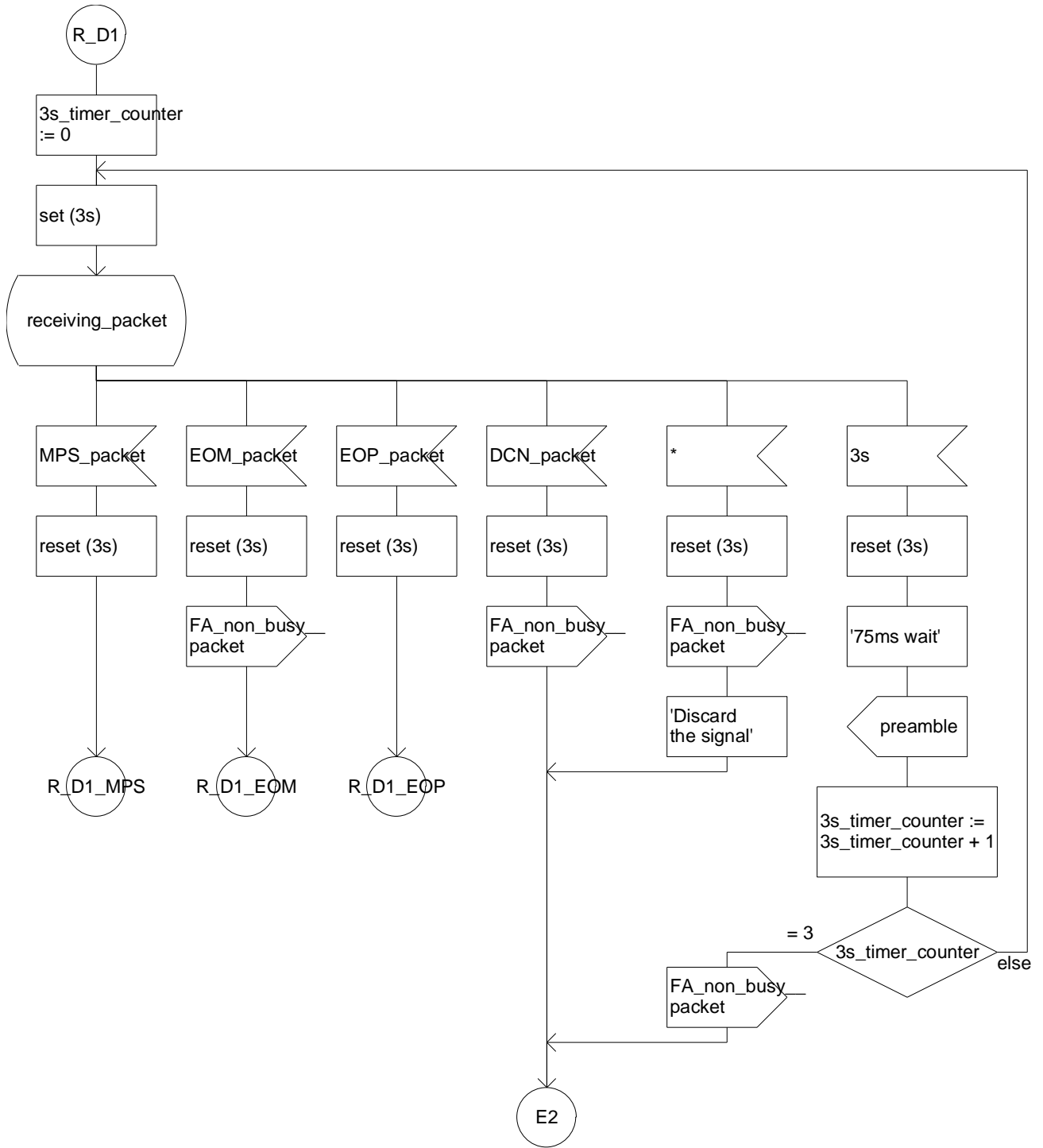

Figure D.15: Reception side FA for NON ECM, Phase D (Basic control flow)

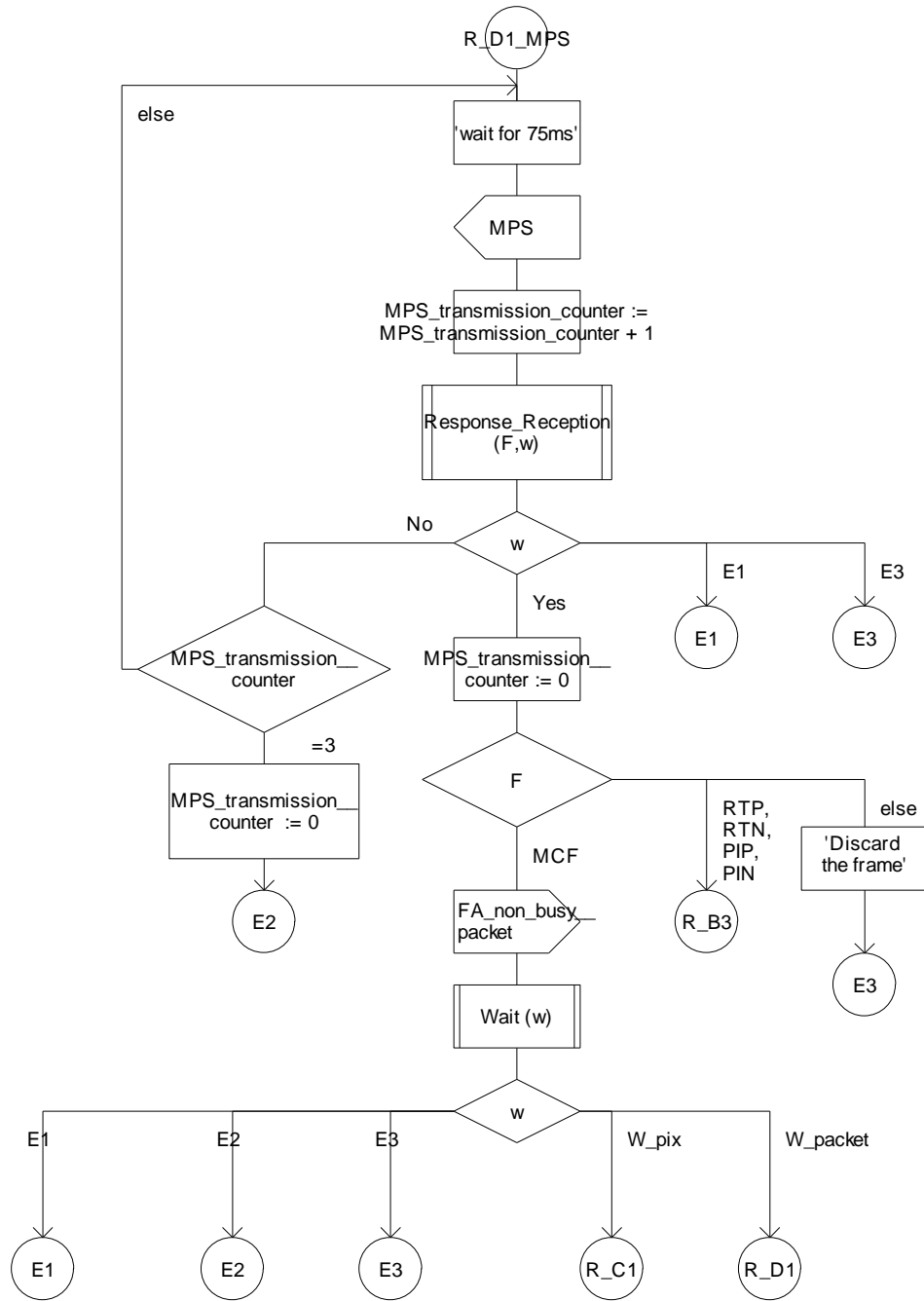

Figure D.16: Reception FA, Phase D (MPS)

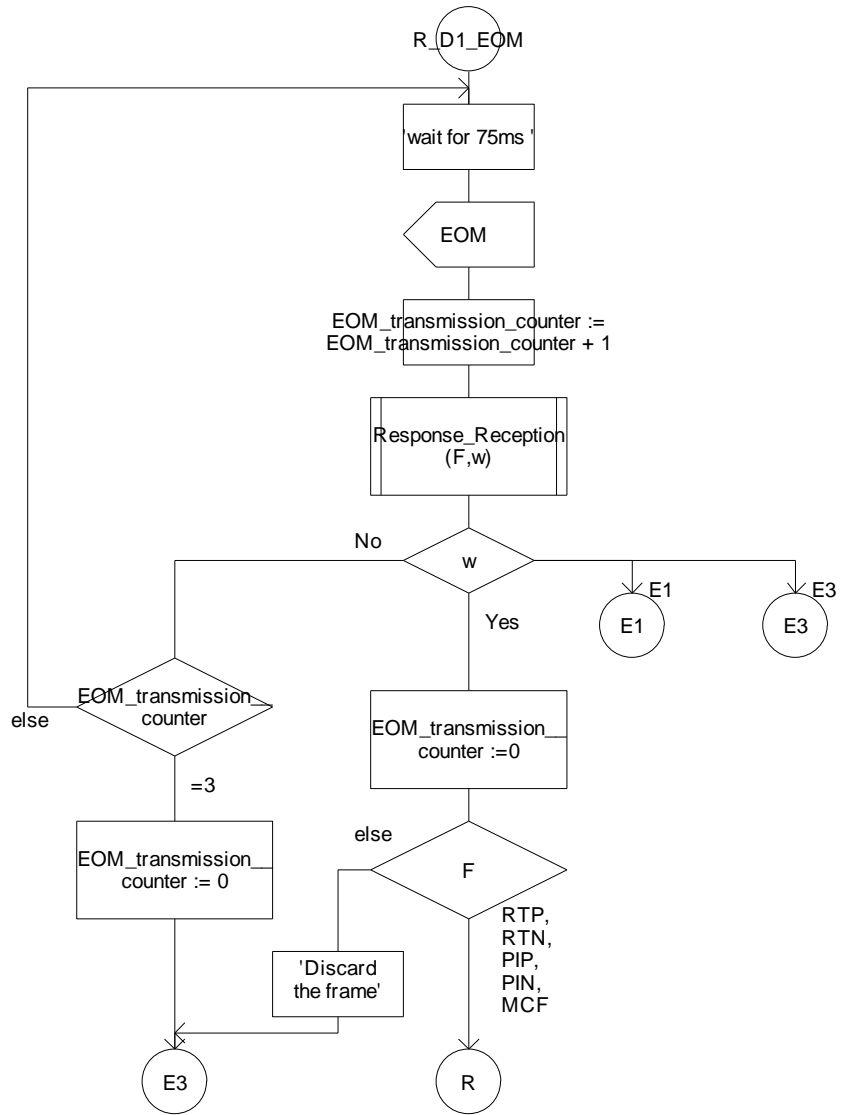

Figure D.17: Reception FA, Phase D (EOM)

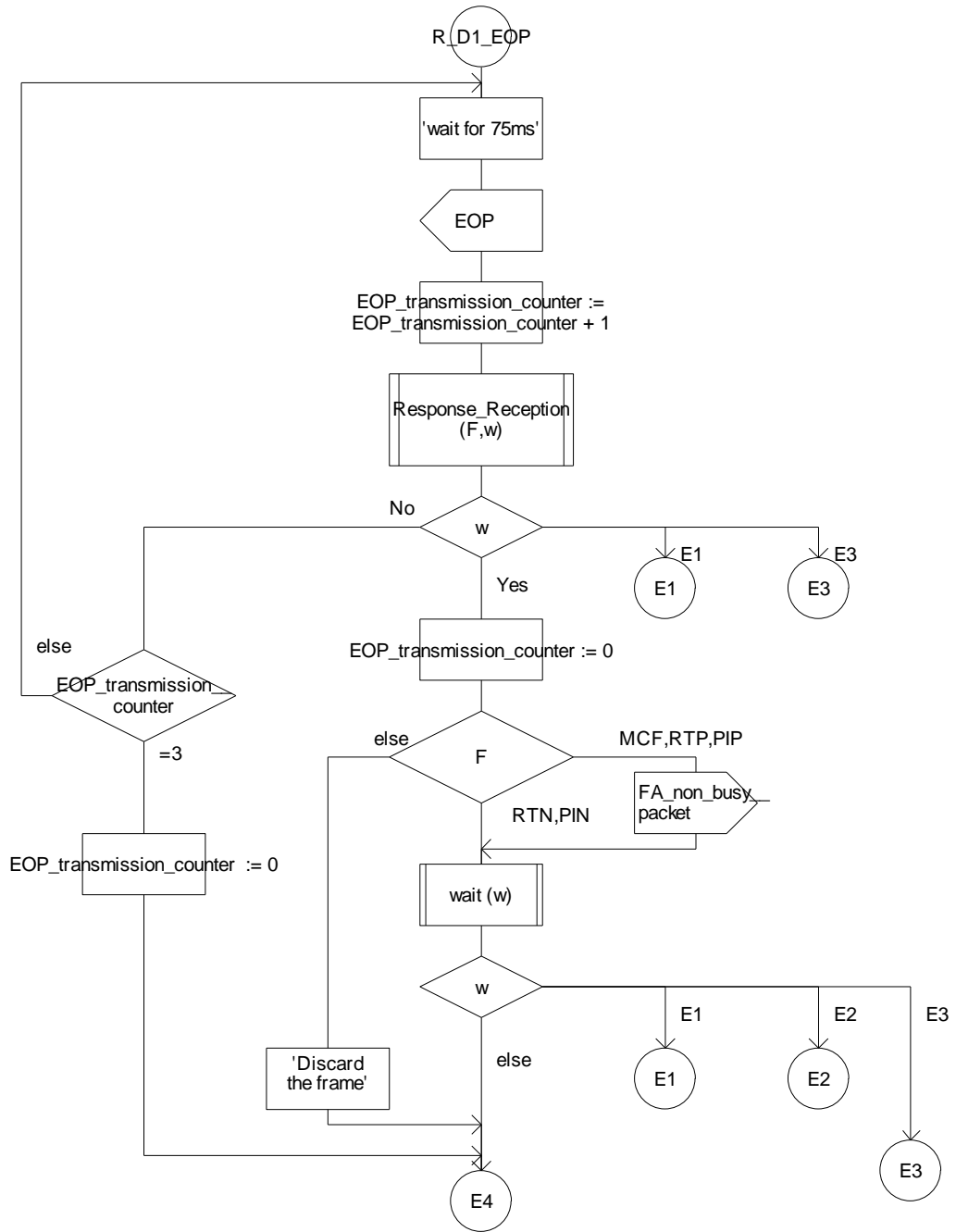

Figure D.18: Reception FA, Phase D (EOP)

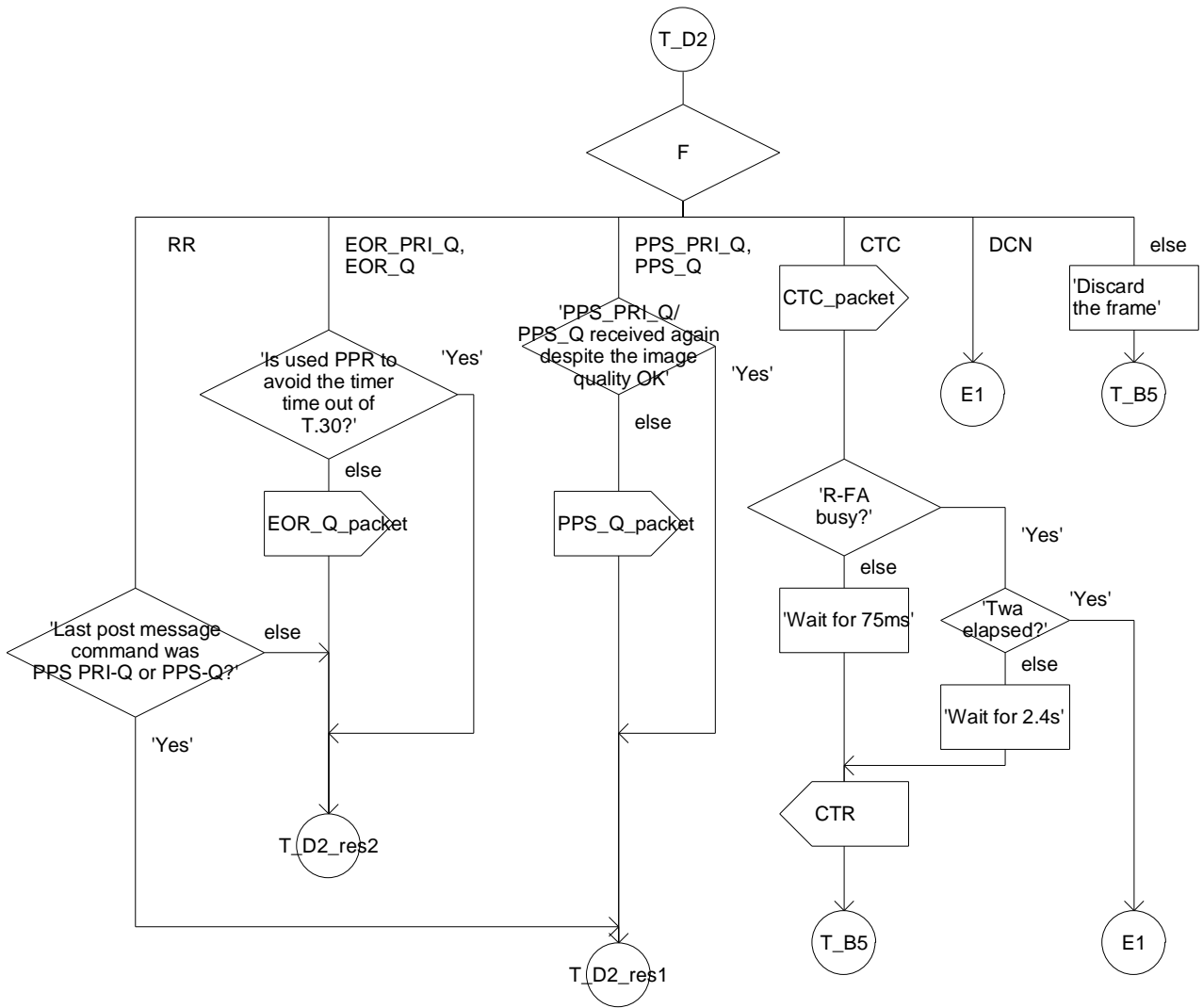

Figure D.19: Transmission side FA for ECM, Phase D (Basic control flow)

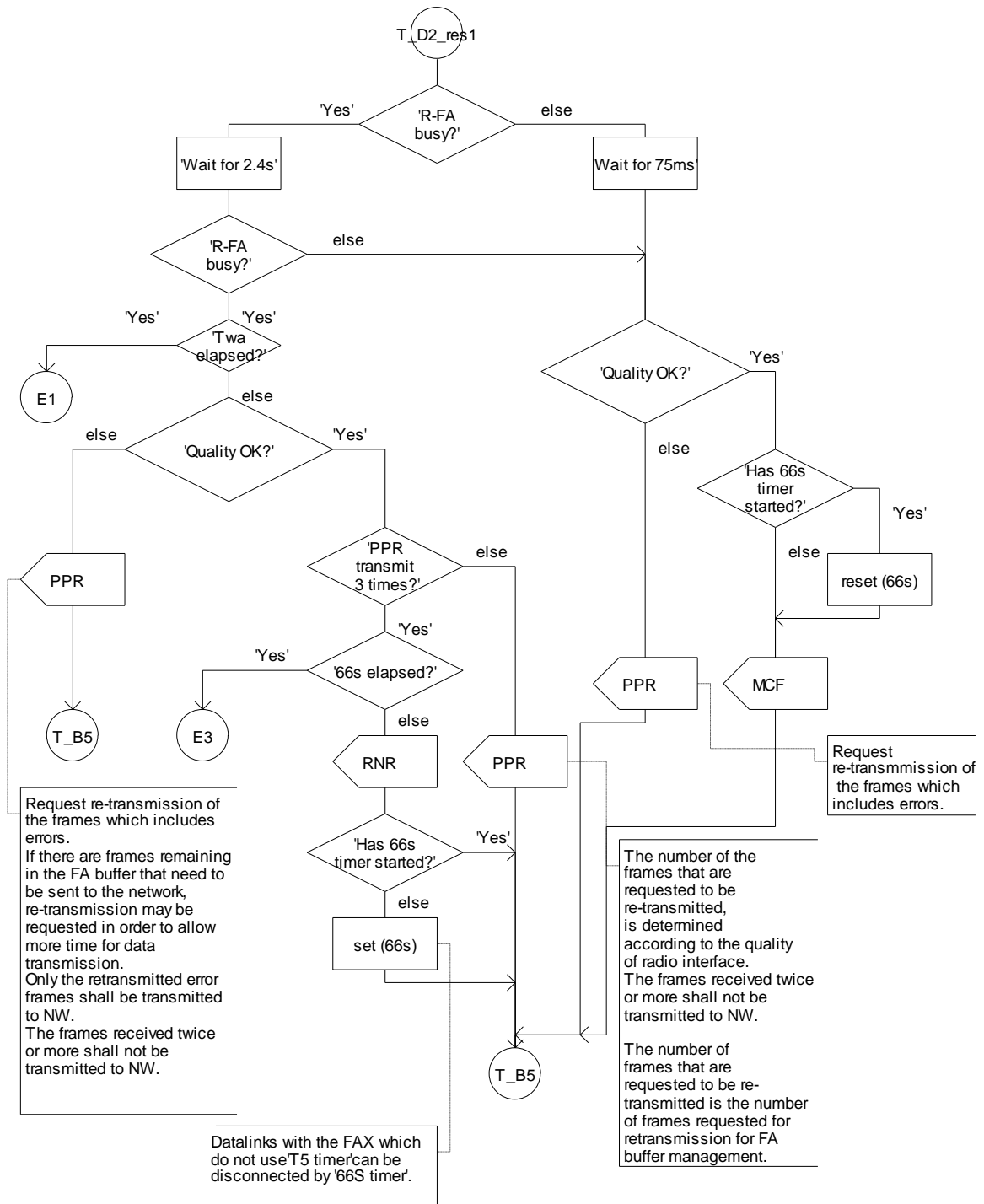

Figure D.20: Selection algorithm for MCF/PPR/RNR

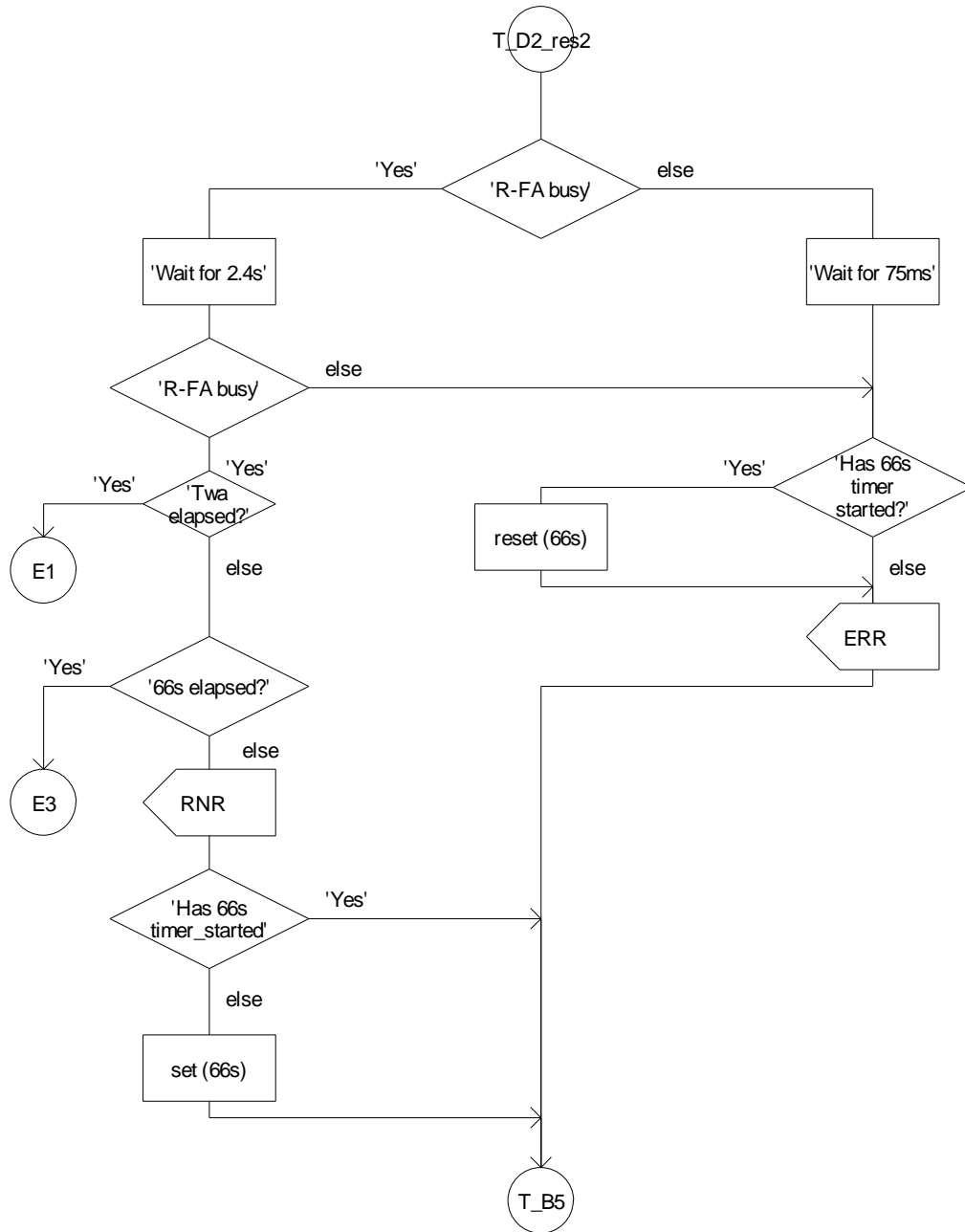

Figure D.21: Selection for ERR / RNR ECM

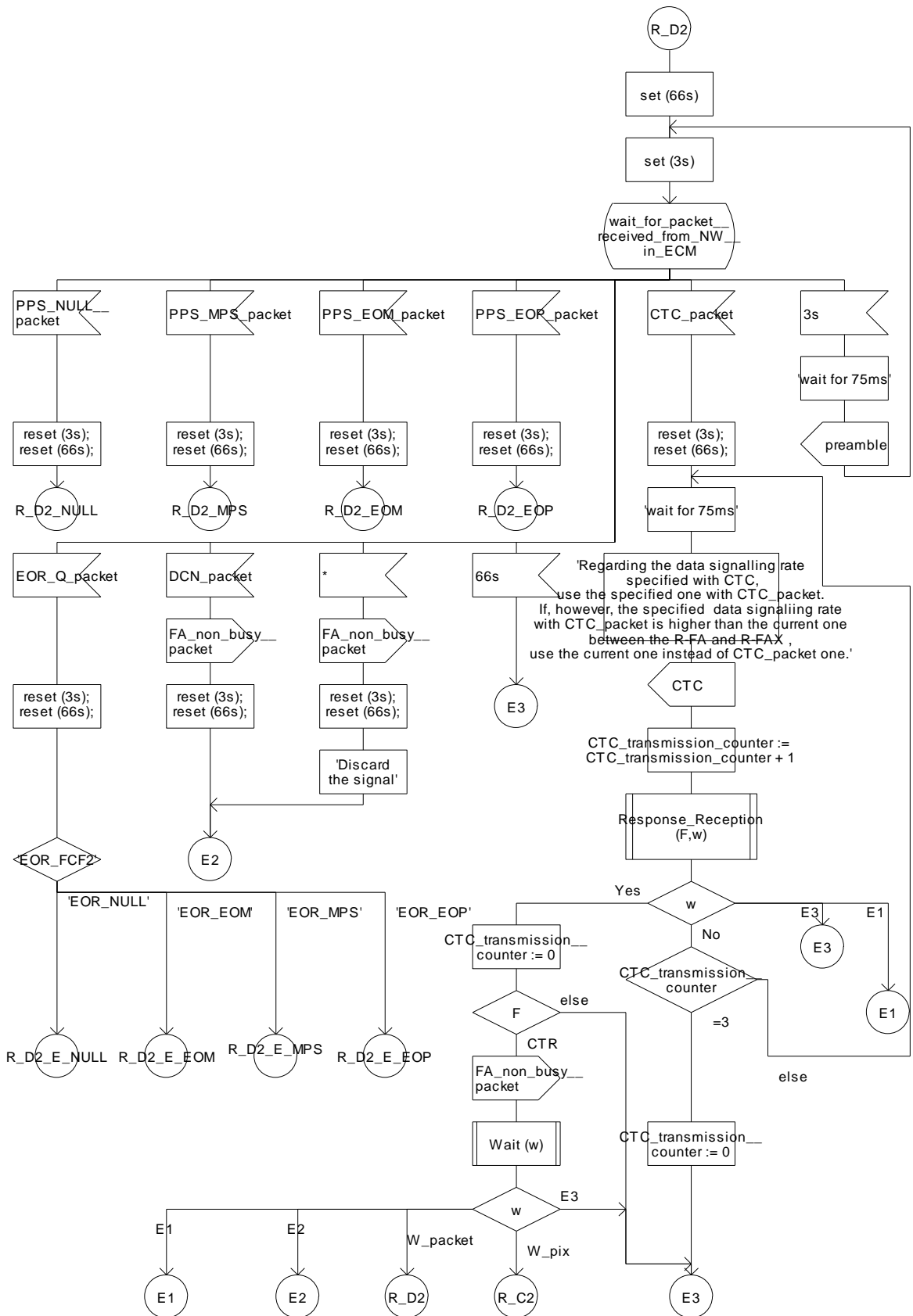

Figure D.22: Reception side FA for ECM, Phase D (Basic control flow)

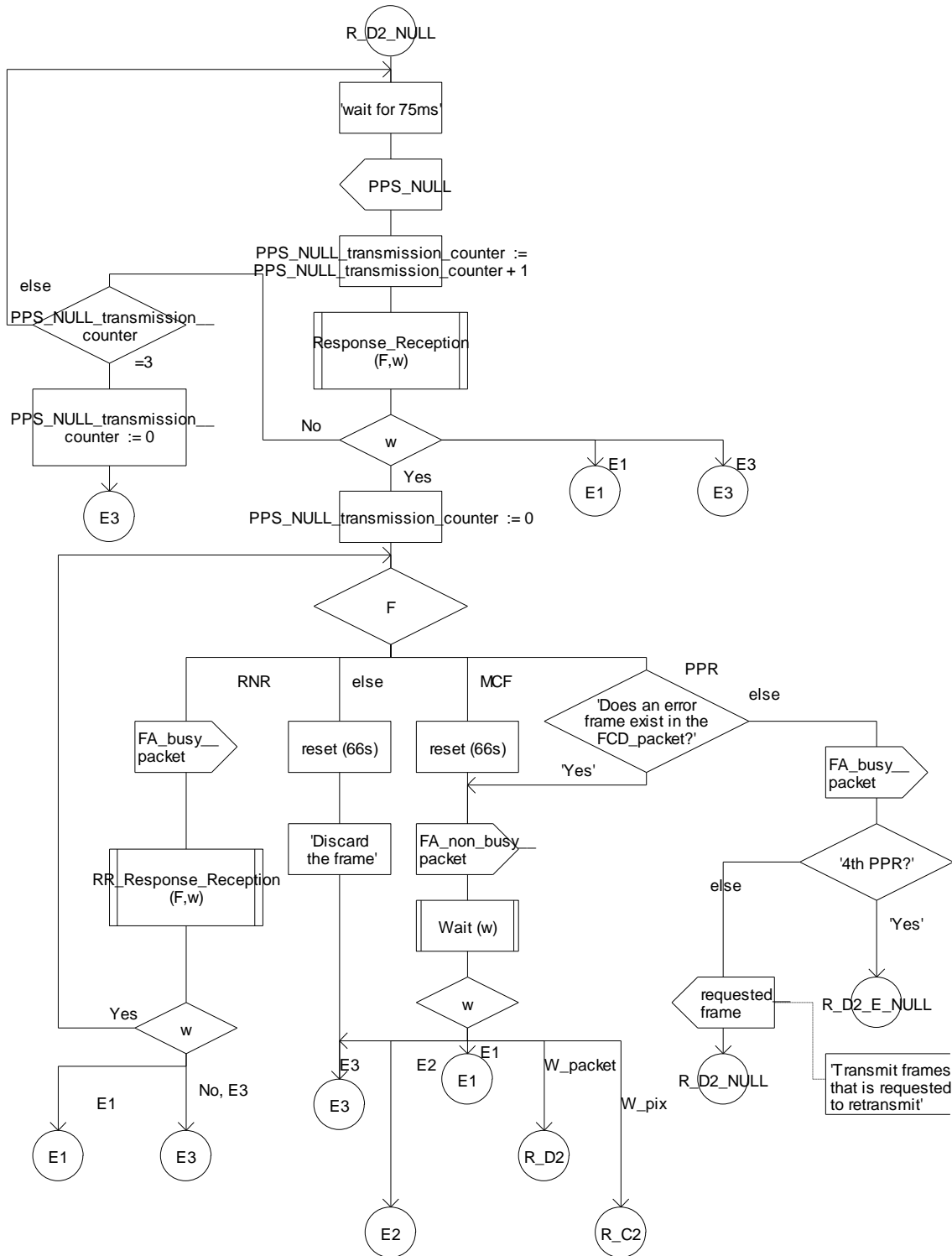

Figure D.23: Reception FA, Phase D (PPS-NULL)

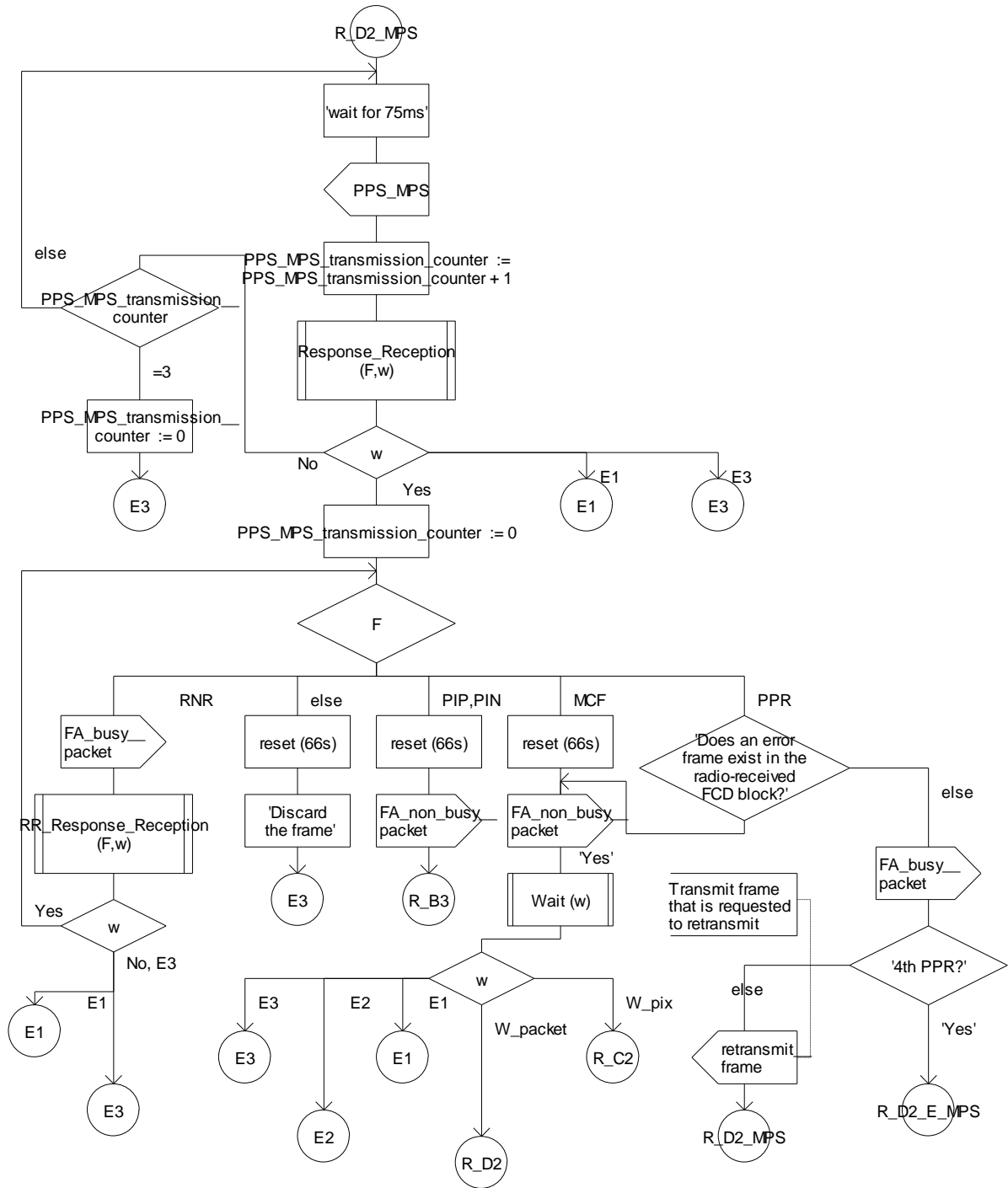

Figure D.24: Reception FA, Phase D (PPS-MPS)

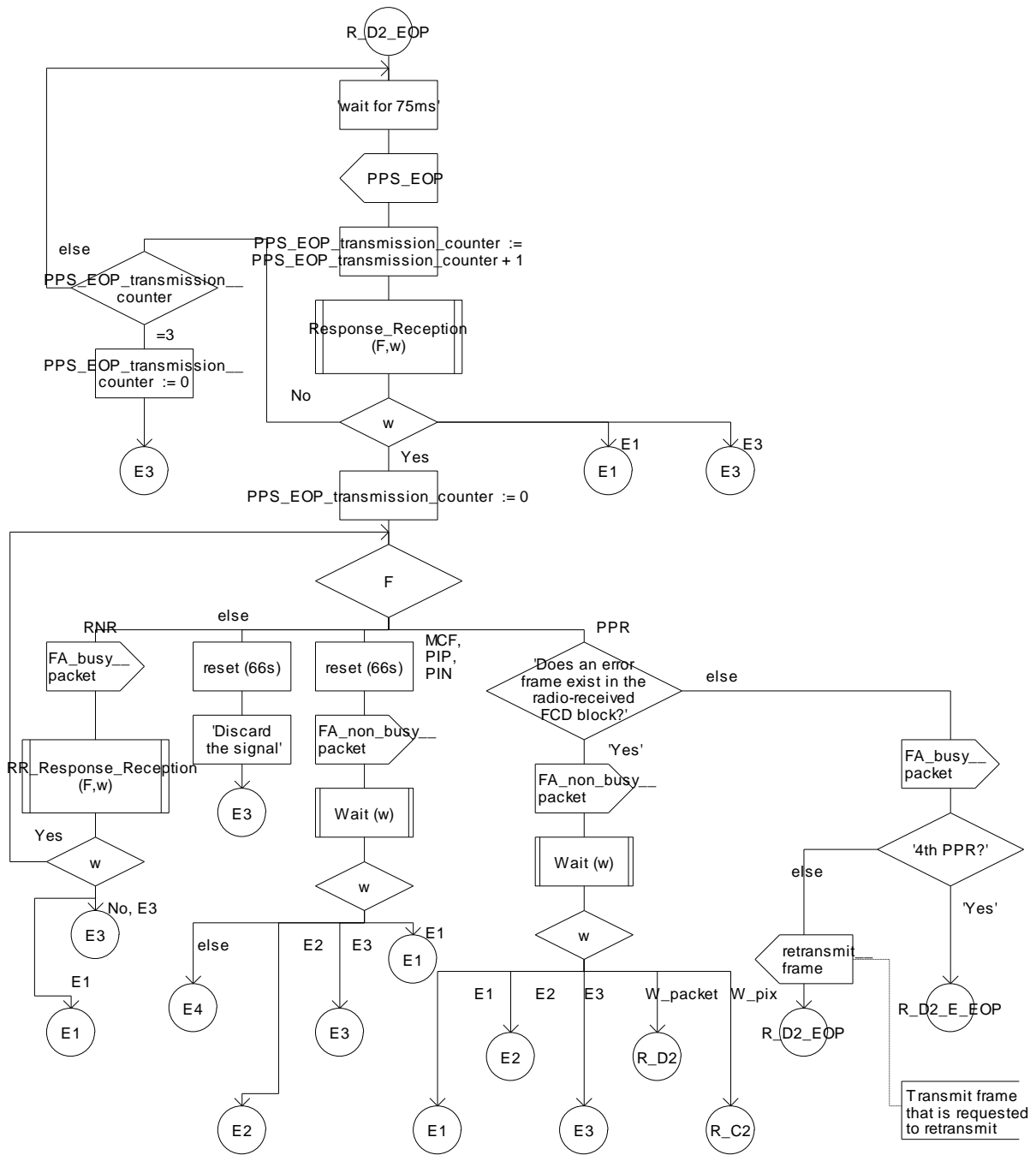

Figure D.25: Reception FA, Phase D (PPS-EOP)

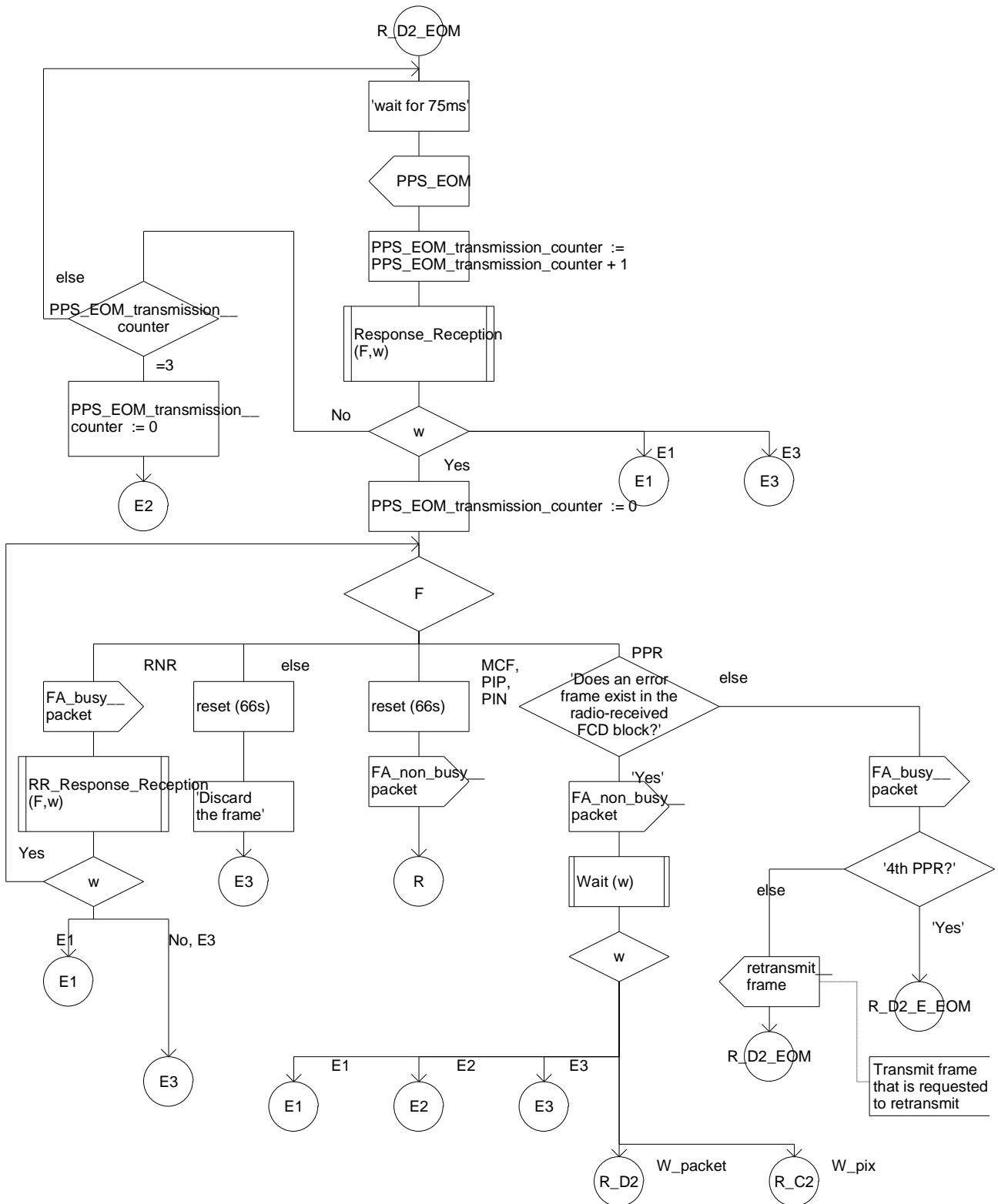

Figure D.26: Reception FA, Phase D (PPS-EOM)

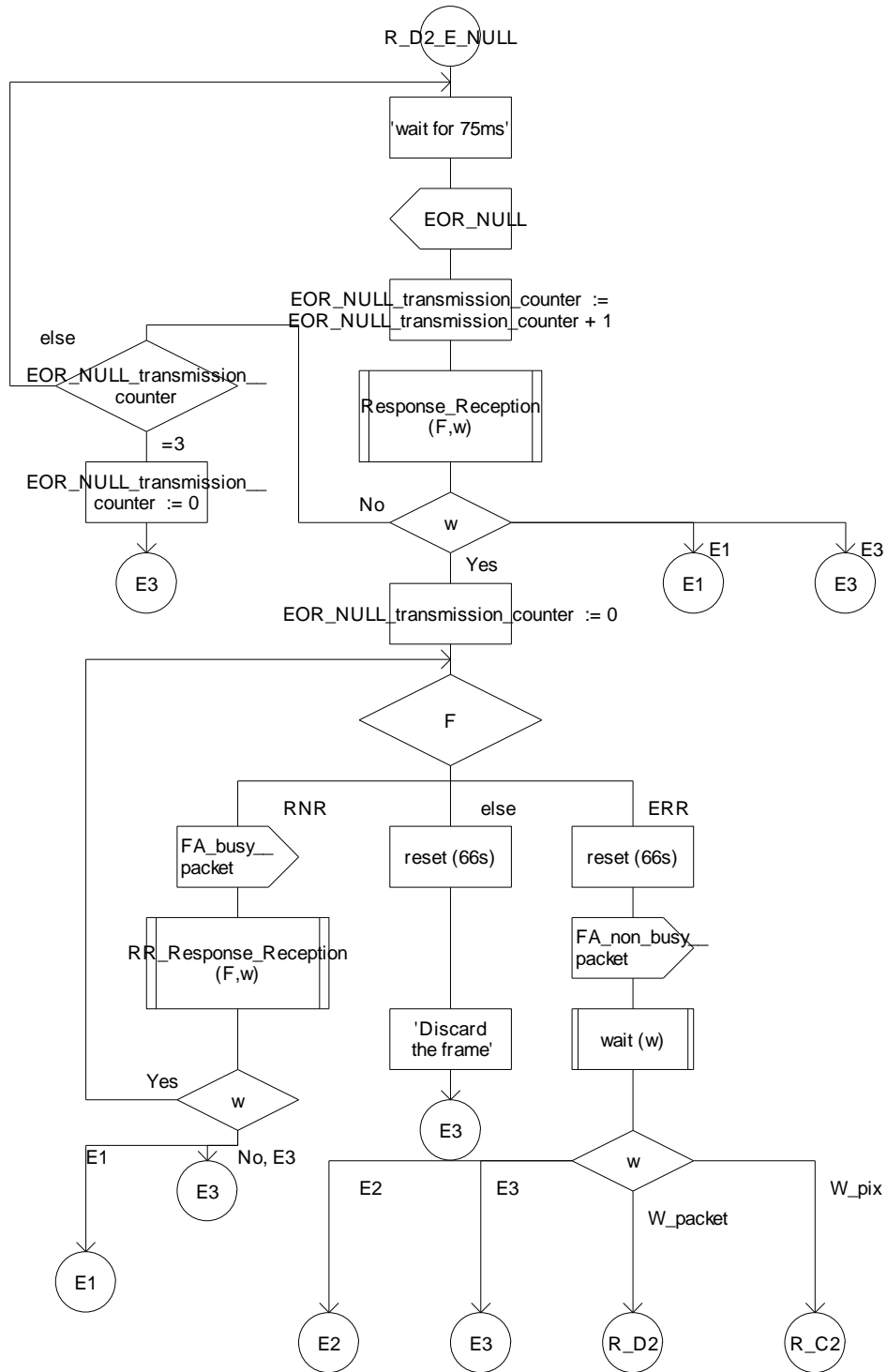

Figure D.27: Reception FA, Phase D (EOR-NULL)

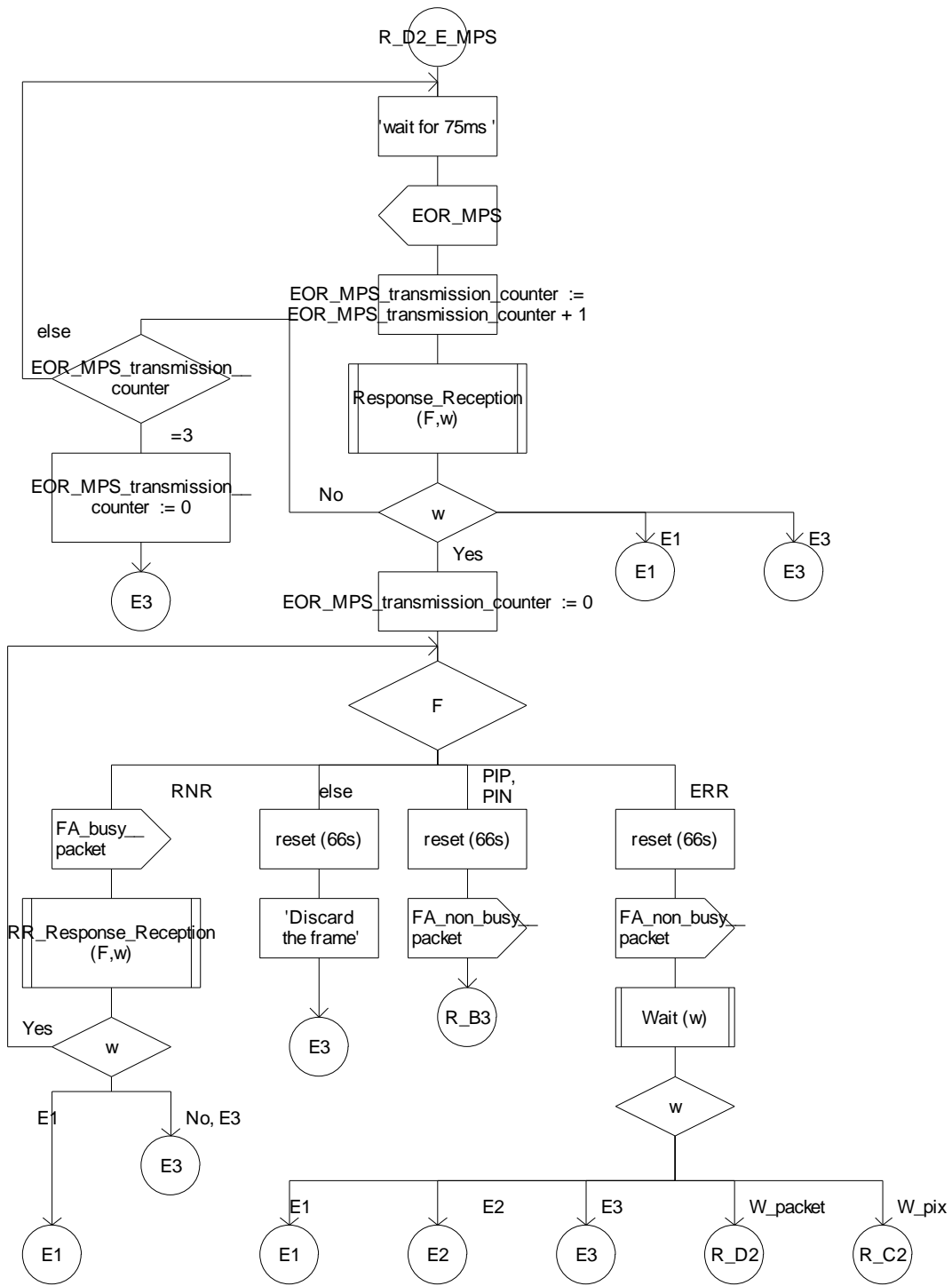

Figure D.28: Reception FA, Phase D (EOR-MPS)

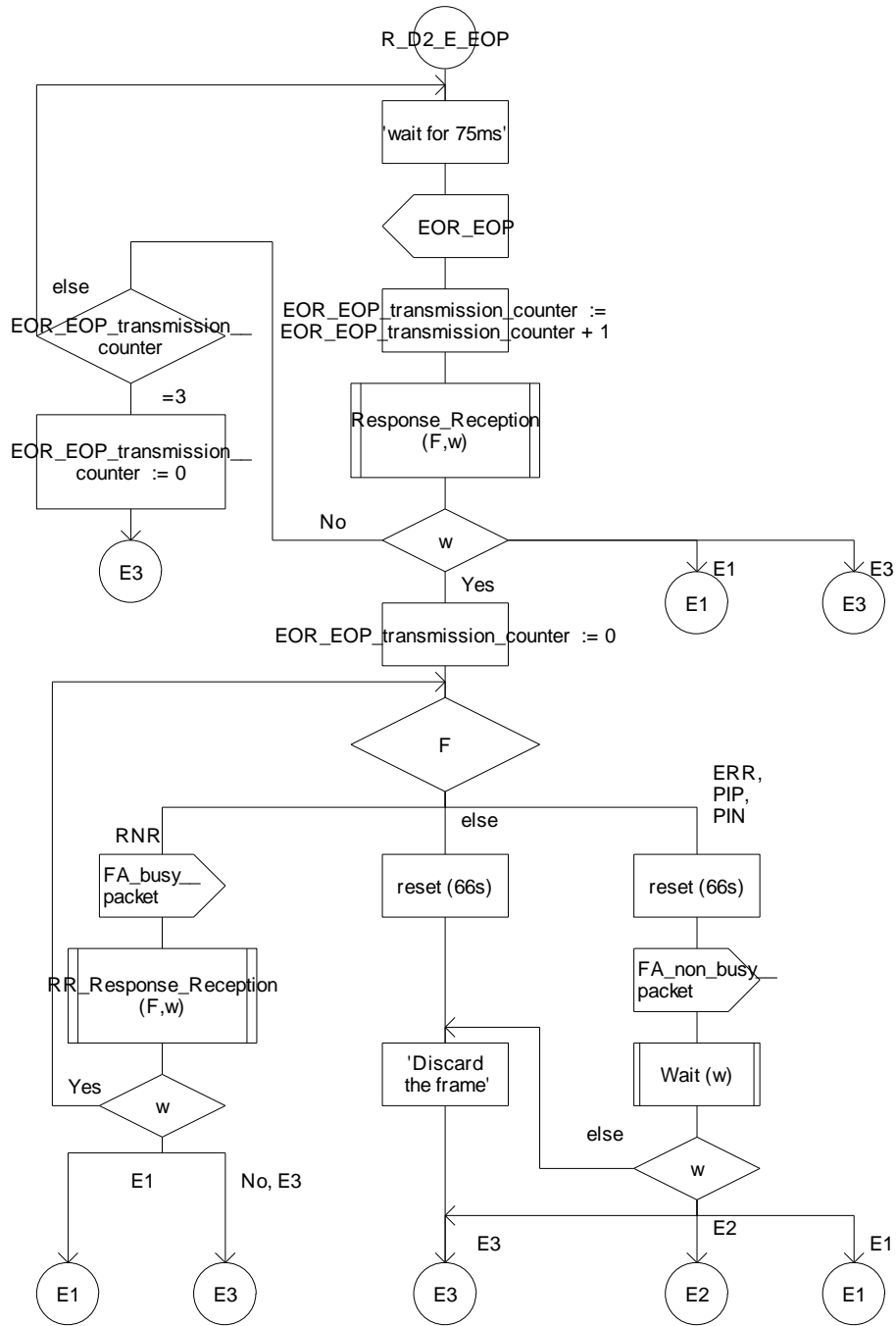

Figure D.29: Reception FA, Phase D (EOR-EOP)

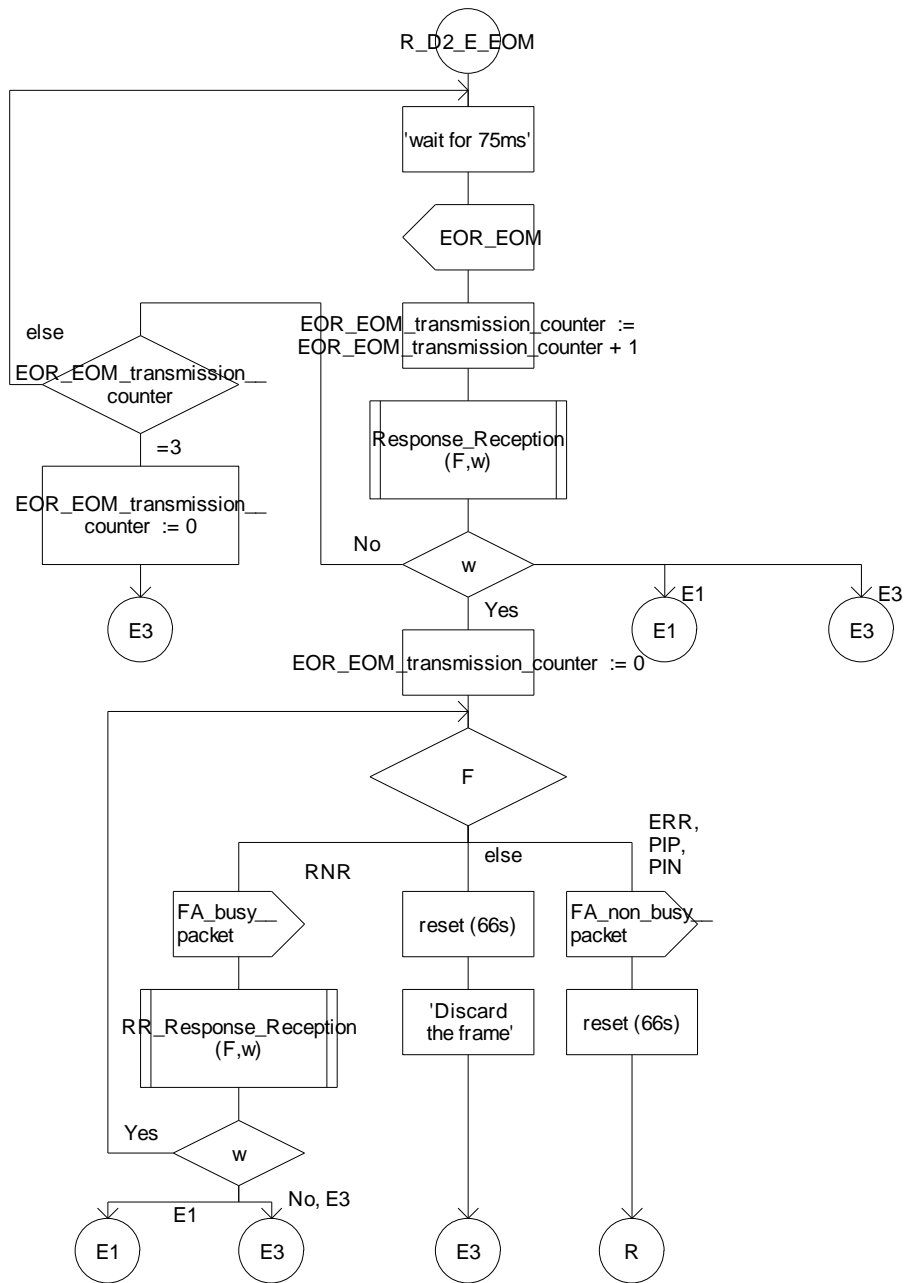

Figure D.30: Reception FA, Phase D (EOR-EOM)

Procedure Command_Reception

```

:fpair
IN/OUT F RECSIGNAL,
IN/OUT w RESULT;
    
```

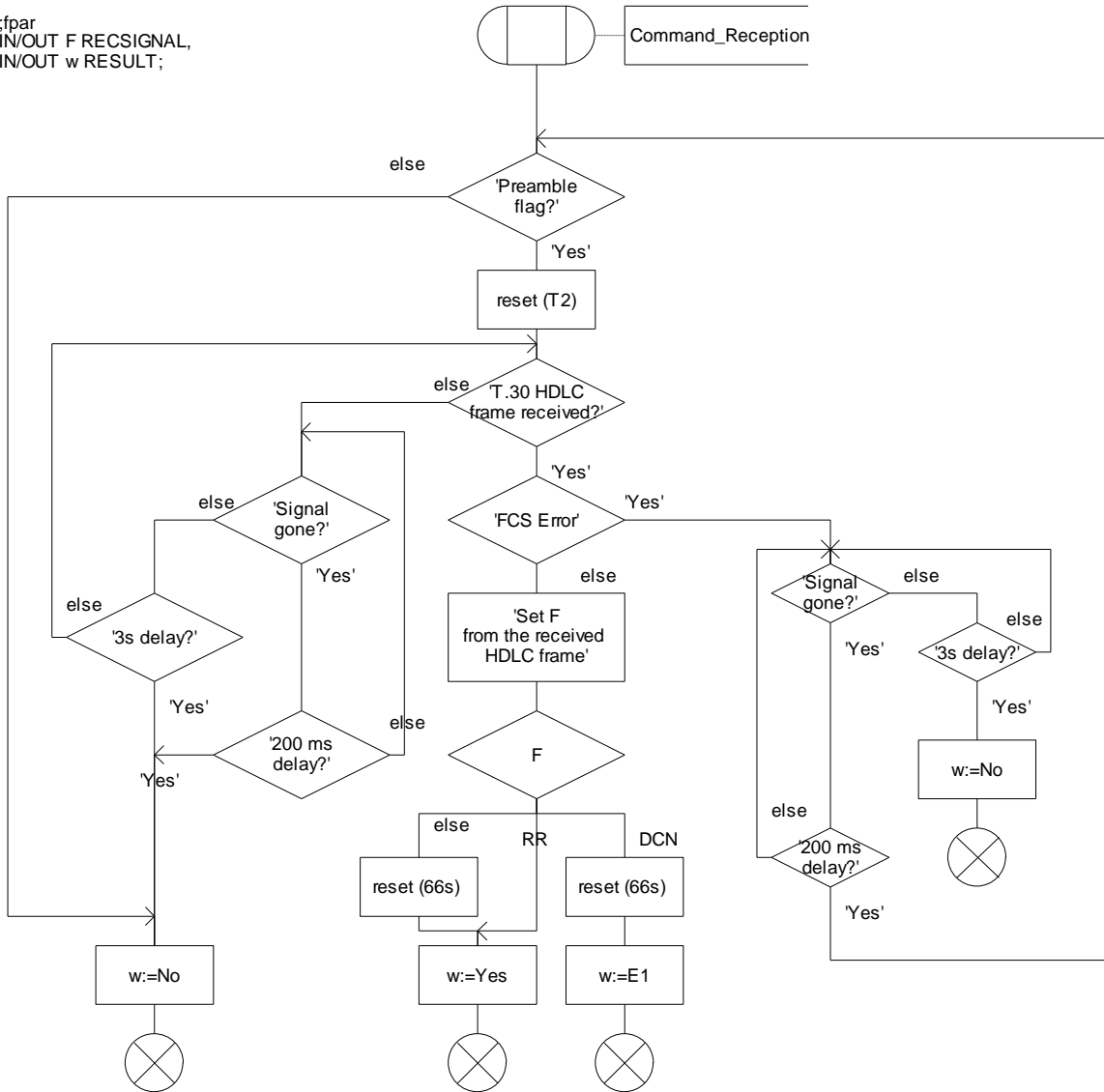

Figure D.31: Command reception subroutine

Procedure Wait

```

;
fpar IN/OUT w RESULT;

```

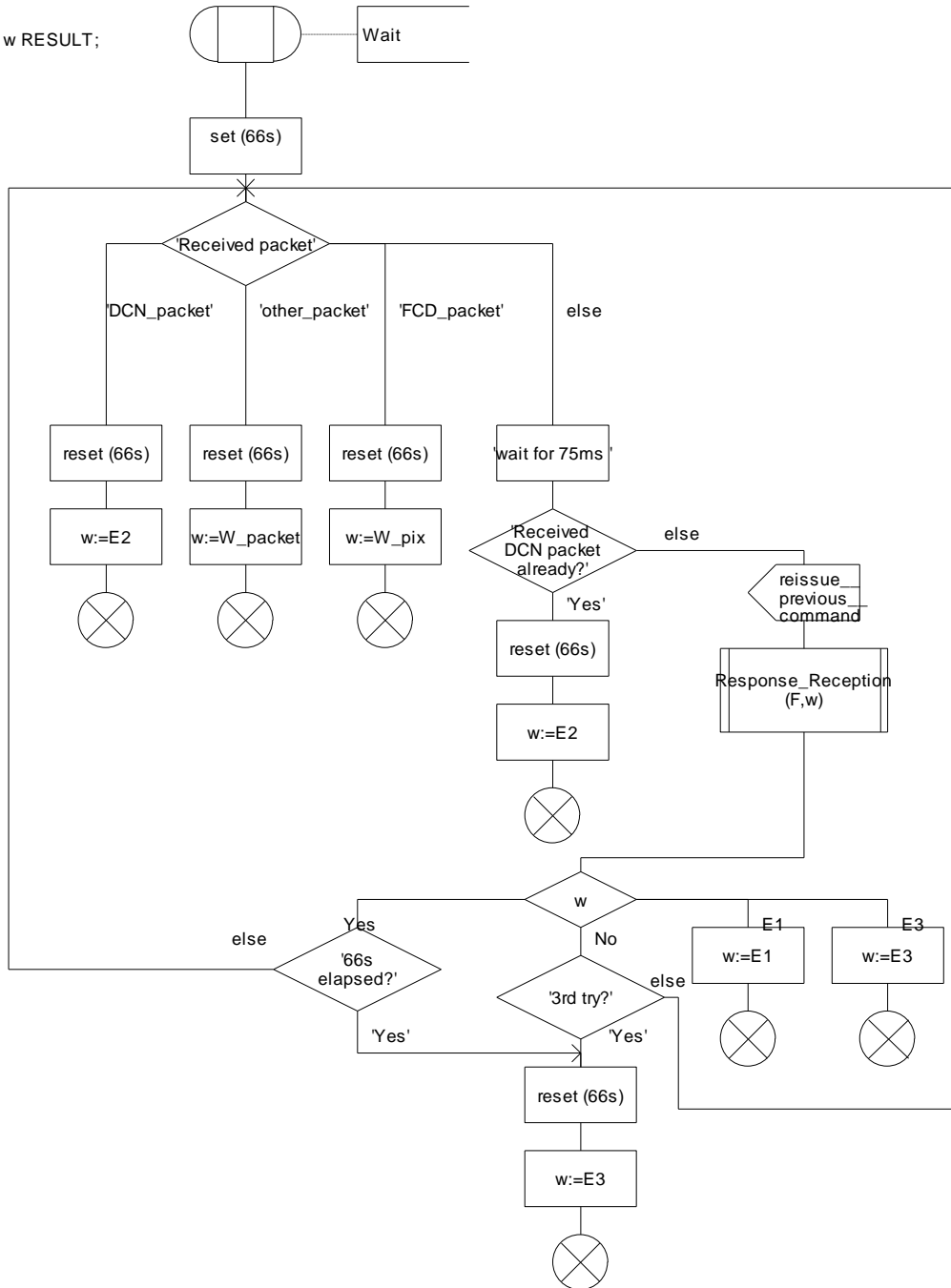

Figure D.32: Wait subroutine

Procedure Response_Reception

```

:
fpar
IN/OUT F RECSIGNAL,
IN/OUT w RESULT;

```

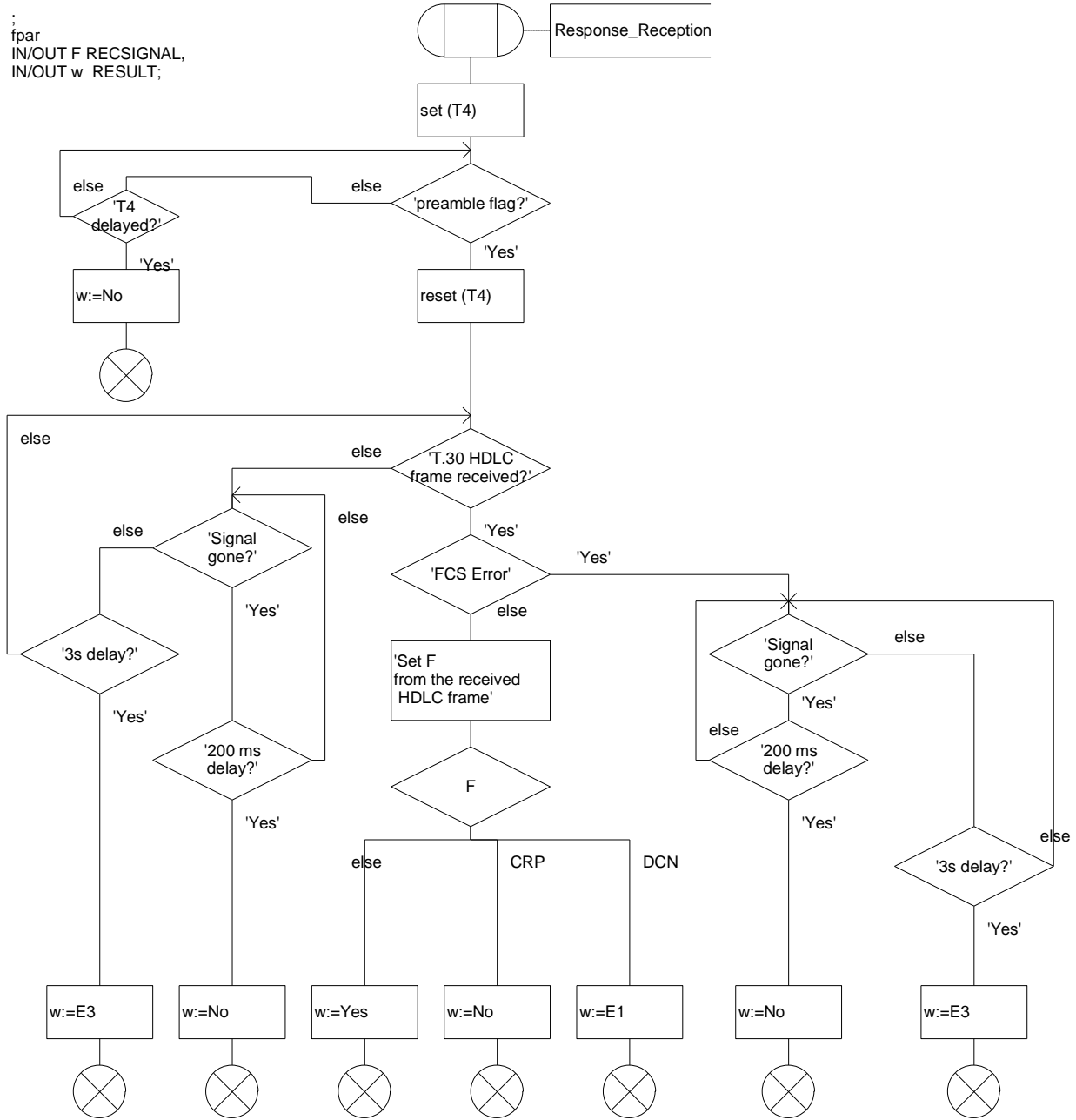

Figure D.33: Response reception subroutine

Procedure RR_Response_Reception

; fpar IN/OUT F RECSIGNAL,
IN/OUT w RESULT;

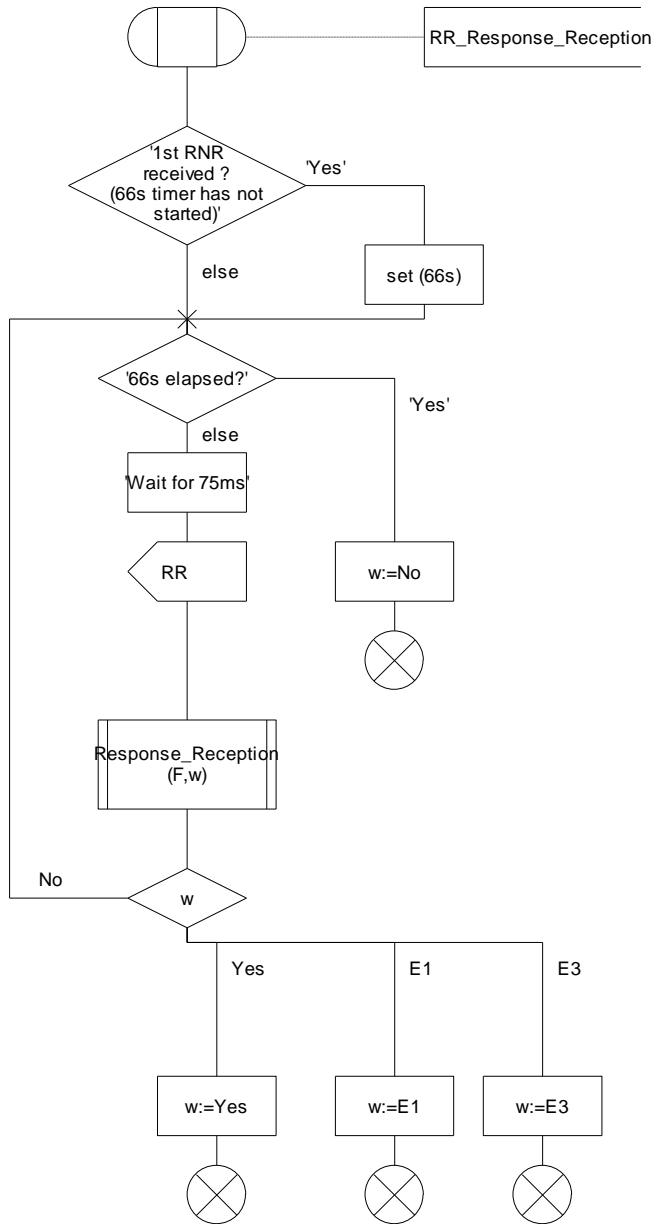

Figure D.34: RR response reception subroutine

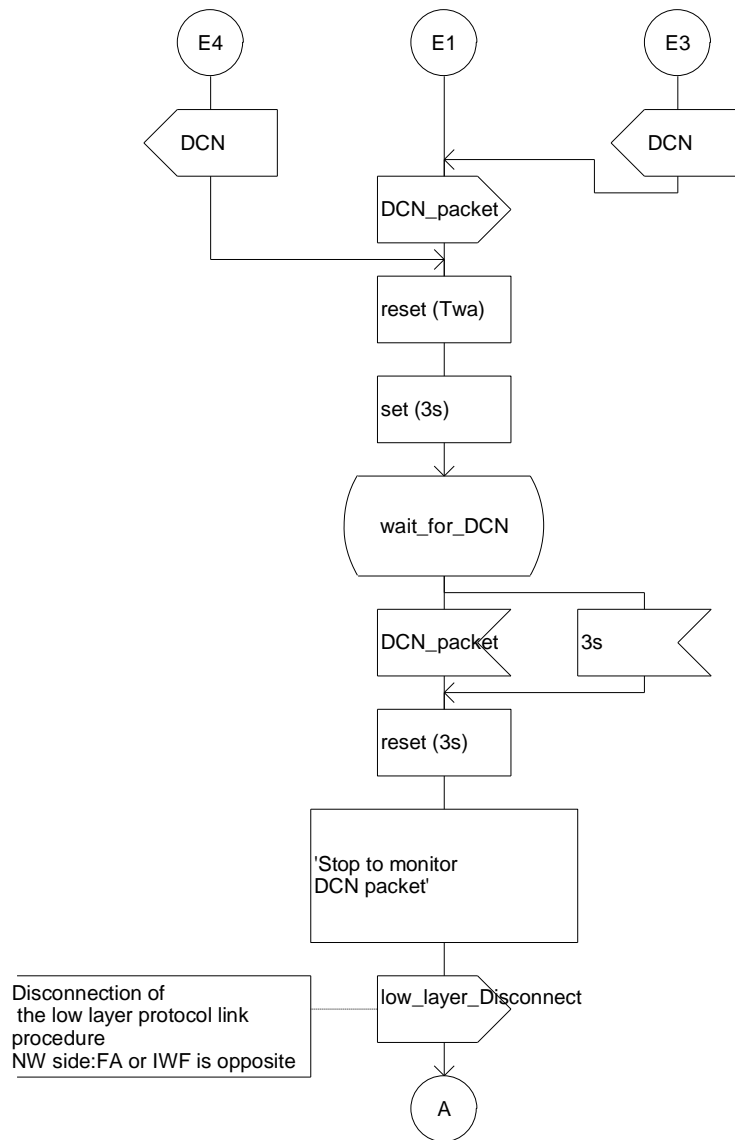

Figure D.35: FA release flow (1)

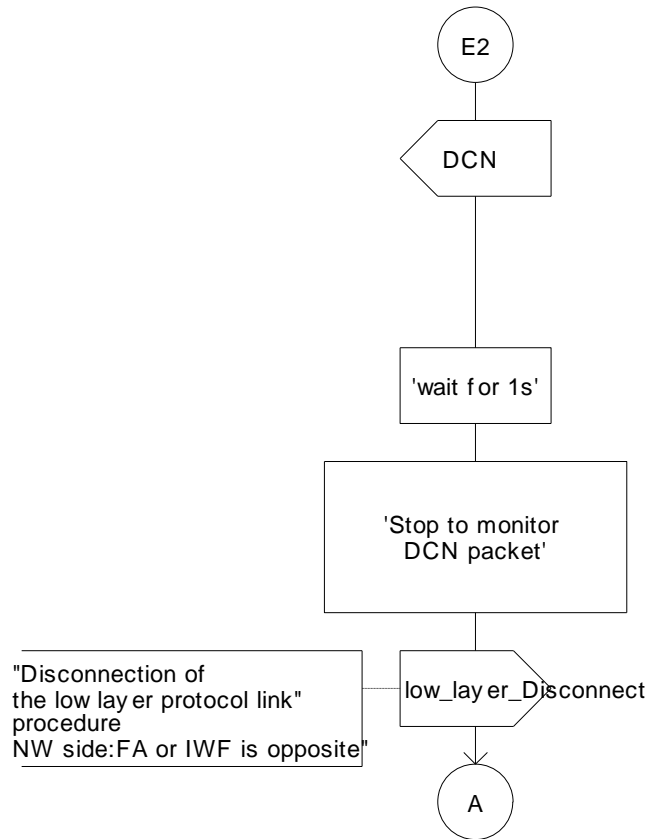

Figure D.36: FA release flow (2)

Table D.2: Specified Timer values

Name of Timer	Timer Value	Refer to
T1	35 ± 5(sec)	ITU-T T.30
T2	6 ± 1(sec)	ITU-T T.30
T4	3,0(sec) ± 15%	ITU-T T.30
Twa	60(sec)	-
Fill_insertion_timer	4,5(sec)	ITU-T T.30
Flag_insertion_timer	50(sec)	ITU-T T.30
66s	66(sec)	ITU-T T.30
3s	3(sec)	-

Annex E (normative): ASN.1 notation

```

ASN.1 notation
3GTS23146 DEFINITIONS AUTOMATIC TAGS ::=
BEGIN
IFPPacket ::= SEQUENCE
{
    type-of-msg      Type-of-msg,
    data-field       Data-Field OPTIONAL
}
Type-of-msg ::= CHOICE
{
    t30-indicator   ENUMERATED
    {
        no-signal,
        cng,
        ced,
        tcf-error-detect,
        fa-busy,
        fa-non-busy,
    },
    data            ENUMERATED
    {
        v21,
        v27-2400,
        v27-4800,
        v29-7200,
        v29-9600,
        v17-7200,
        v17-9600,
        v17-12000,
        v17-14400,
        ...
    }
}
Data-Field ::= SEQUENCE OF SEQUENCE
{
    field-type      ENUMERATED
    {
        hdlc-data,
        hdlc-sig-end,
        hdlc-fcs-OK,
        hdlc-fcs-BAD,
        hdlc-fcs-OK-sig-end,
        hdlc-fcs-BAD-sig-end,
        t4-non-ecm-data,
        t4-non-ecm-sig-end
    },
    field-data      OCTET STRING (SIZE(1..65535)) OPTIONAL
}
UDPTLPacket ::= SEQUENCE
{
    seq-number      INTEGER (0..65535),
    primary-ifp-packet TYPE-IDENTIFIER.&Type (IFPPacket),
    error-recovery  CHOICE
    {
        secondary-ifp-packets SEQUENCE OF TYPE-IDENTIFIER.&Type (IFPPacket),
        fec-info              SEQUENCE
        {
            fec-npackets     INTEGER,
            fec-data          SEQUENCE OF OCTET STRING
        }
    }
}
END

```

Annex F (informative): Change history

Change history							
Date	TSG #	TSG Doc.	CR	Rev	Subject/Comment	Old	New
July 2000	CN#08	NP-000222			Approved to be made v4.0.0 and put under change control	2.0.0	4.0.0
09-2000	CN#09	NP-000476	001		Correction of SDL Diagrams	4.0.0	4.1.0
09-2000	CN#09	NP-000552	002		Modification of V.25bis to V.250	4.0.0	4.1.0
06-2002	CN#16				Upgraded to v5.0.0	4.1.0	5.0.0
12-2004	CN#26				Upgraded to v6.0.0	5.0.0	6.0.0
06-2007	CT#36				Upgraded to v7.0.0	6.0.0	7.0.0
12-2008	CT#42				Upgraded to v8.0.0 due to simple upgrade without no technical change	7.0.0	8.0.0
12-2009	CT#46				Automatic upgrade from previous Release	8.0.0	9.0.0
03-2011	CT#51				Automatic upgrade from previous Release version 9.0.0	9.0.0	10.0.0
03-2011	CT#51				Correction of heading and numbering made by MCC	10.0.0	10.0.1
09-2012	CT#57				Automatic upgrade from previous Release version 10.0.1	10.0.1	11.0.0