

3GPP TS 23.127 V6.1.0 (2004-06)

Technical Specification

3rd Generation Partnership Project; Technical Specification Group Services and System Aspects; Virtual Home Environment (VHE) / Open Service Access (OSA) (Release 6)



The present document has been developed within the 3rd Generation Partnership Project (3GPP™) and may be further elaborated for the purposes of 3GPP.

The present document has not been subject to any approval process by the 3GPP Organizational Partners and shall not be implemented. This Specification is provided for future development work within 3GPP only. The Organizational Partners accept no liability for any use of this Specification. Specifications and reports for implementation of the 3GPP™ system should be obtained via the 3GPP Organizational Partners' Publications Offices.

Keywords

UMTS, VHE, OSA, MEXE, CAMEL, USAT

3GPP

Postal address

3GPP support office address

650 Route des Lucioles - Sophia Antipolis
Valbonne - FRANCE
Tel.: +33 4 92 94 42 00 Fax: +33 4 93 65 47 16

Internet

<http://www.3gpp.org>

Copyright Notification

No part may be reproduced except as authorized by written permission.
The copyright and the foregoing restriction extend to reproduction in all media.

© 2004, 3GPP Organizational Partners (ARIB, ATIS, CCSA, ETSI, TTA, TTC).
All rights reserved.

Contents

Foreword	5
1 Scope	6
2 References.....	6
2.1 Normative references.....	6
3 Definitions and abbreviations	7
3.1 Definitions	7
3.2 Abbreviations.....	7
4 Virtual Home Environment	8
4.1 Personal Service Environment	8
4.1.1 Void	8
4.2 Support of Virtual Home Environment Toolkits	8
4.2.1 USAT	8
4.2.2 MExE	8
4.2.3 OSA	8
4.2.3.1 Support of HE- VASPs	8
4.2.4 CAMEL	9
5 Open Service Access.....	9
5.1 Overview of the Open Service Access.....	10
5.2 Basic mechanisms in the Open Service Access	12
5.3 Handling of end-user related security	13
5.3.1 End-user authorisation to applications	13
5.3.2 Application authorisation to end-users.....	13
5.3.3 End-user's privacy	14
6 Framework service capability features	14
6.1 Trust and Security Management Functions.....	14
6.1.1 Initial Contact	14
6.1.2 Authentication.....	15
6.1.3 OSA Access	15
6.2 Discovery	15
6.3 Integrity Management functions.....	16
6.3.1 Load Manager.....	16
6.3.2 Fault Manager.....	16
6.3.3 Heartbeat Management	16
6.3.4 OAM.....	16
6.5 Policy Management.....	16
7 Network service capability features	16
7.1 Call Control	16
7.1.1 Mapping of OSA APIs in CS domain	17
7.1.2 Mapping of OSA APIs in IMS	17
7.2 Data Session Control.....	18
7.3 Mobility.....	18
7.4 Terminal Capabilities	19
7.5 User Interaction.....	19
7.7 Charging	19
7.8 Account Management	20
7.9 Presence.....	20
7.9.1 Mapping of OSA APIs	20
7.10 [void]	21
7.11 [void]	21
8 OSA Internal API.....	21
8.1 OSA Access and Discovery.....	21
8.2 Registration of network service capability features at the frame work	21

8.2.1	Service Registration.....	22
8.2.2	Service Factory	22
8.3	Integrity Management.....	22
8.3.1	Load Management.....	22
8.3.2	Heartbeat Management	22
8.3.3	Fault Management.....	22
9	Parlay X Web Services: OSA at a higher level of abstraction	22
9.1	General	22
9.1.1	Deployment Scenario A: Web Services to OSA.....	24
9.1.2	Deployment Scenario B: Web Services to Network Element	25
9.2	Third Party Call	25
9.3	Network-Initiated Third Party Call	25
9.4	SMS	26
9.5	Multimedia Message.....	26
9.6	Payment.....	26
9.7	Account Management	27
9.8	User Status.....	27
9.9	Terminal Location	27
Annex A (informative): Change History		28

Foreword

This Technical Specification (TS) has been produced by the 3rd Generation Partnership Project (3GPP).

The contents of the present document are subject to continuing work within the TSG and may change following formal TSG approval. Should the TSG modify the contents of the present document, it will be re-released by the TSG with an identifying change of release date and an increase in version number as follows:

Version x.y.z

where:

- x the first digit:
 - 1 presented to TSG for information;
 - 2 presented to TSG for approval;
 - 3 or greater indicates TSG approved document under change control.
- y the second digit is incremented for all changes of substance, i.e. technical enhancements, corrections, updates, etc.
- z the third digit is incremented when editorial only changes have been incorporated in the document.

1 Scope

The present document specifies the stage 2 of the Virtual Home Environment.

Virtual Home Environment (VHE) is defined as a concept for Personal Service Environment (PSE) portability across network boundaries and between terminals. The concept of VHE is such that users are consistently presented with the same personalised features, User Interface customisation and services in whatever network and whatever terminal (within the capabilities of the terminal and the network), wherever the user may be located.

For Release 5, e.g. CAMEL, MExE, OSA and USAT are considered the mechanisms supporting the VHE concept.

Stage 2 specifications for CAMEL, MExE and USAT are addressed in other documents [1], [2], [3]. However, there is no separate stage 2 specification document for OSA. Therefore, the present document addresses stage 2 aspects for OSA.

2 References

The following documents contain provisions which, through reference in this text, constitute provisions of the present document.

- References are either specific (identified by date of publication, edition number, version number, etc.) or non-specific.
- For a specific reference, subsequent revisions do not apply.
- For a non-specific reference, the latest version applies.

2.1 Normative references

- [1] 3GPP TS 23.057: "Mobile Execution Environment (MExE); Functional description - Stage 2".
- [2] 3GPP TS 23.078: "Customised Applications for Mobile network Enhanced Logic (CAMEL) (Phase3); Functional description - Stage 2".
- [3] 3GPP TS 31.111: "USIM Application Toolkit (USAT)".
- [4] 3GPP TS 22.101: "Service Aspects; Service Principles".
- [5] 3GPP TS 22.121: "Service Aspects; The Virtual Home Environment".
- [6] void
- [7] 3GPP TS 22.127: "Service Aspects; Stage 1 Service Requirement for the Open Service Access (OSA)".
- [8] 3GPP TS 23.228: "IP Multimedia Subsystem (IMS) Stage 2".
- [9] 3GPP TS 22.078: "Customised Applications for Mobile network Enhanced Logic (CAMEL); Service description, Stage 1".
- [10] 3GPP TS 23.218: "IP Multimedia (IM) Session Handling; IP Multimedia (IM) call model".
- [11] 3GPP TS 22.141: "Presence Service; Stage 1".
- [12] void
- [13] 3GPP TS 23.271: "Functional stage 2 description of LCS".
- [14] 3GPP TS 23.141: "Presence Service; Architecture and Functional Description".

3 Definitions and abbreviations

3.1 Definitions

For the purposes of the present document, the terms and given in 3G TS 22.101 and 3G TR 22.905 and the following definitions apply:

Applications: software components providing services to end-users by utilising service capability features.

Home Environment: responsible for overall provision of services to users.

Home Environment Value Added Service Provider: see [5].

Interface: listing and semantics of the methods and attributes provided by an object that belongs to a Service Capability Feature.

OSA API: standardised API used by applications to access service capability features.

OSA Internal API: standardised API between framework and service capability servers.

Personal Service Environment: contains personalised information defining how subscribed services are provided and presented towards the user

NOTE: The Personal Service Environment is defined in terms of one or more User Profiles.

Service Capabilities: See [7].

Service Capability Feature: See [7].

Service Capability Server: Functional Entity providing OSA interfaces towards an application.

Services: See [5].

User Profile: See [5].

User Services Profile: See [5].

Value Added Service Provider: See [5].

Virtual Home Environment: See [5].

3.2 Abbreviations

For the purposes of the present document, the abbreviations defined in GSM 01.04 and in 3G TR 21.905 and the following apply:

API	Application Programming Interface
CAMEL	Customised Application For Mobile Network Enhanced Logic
CAP	CAMEL Application Part
CSE	CAMEL Service Environment
GMLC	Gateway Mobile Location Center
HE	Home Environment
HE-VASP	Home Environment Value Added Service Provider
HSS	Home Subscriber Server
IMS	IP Multimedia Core Network Subsystem
ISC	IMS Service Control
LCS	Location Services
MAP	Mobile Application Part
MEExE	Mobile Execution Environment
MRF	Media Resource Function
MRFC	Media Resource Function Controller
MRFP	Media Resource Function Protocol

OSA	Open Service Access
PSE	Personal Service Environment
SCF	Service Capability Feature
SCS	Service Capability Server
S-CSCF	Serving Call Session Control Function
SIM	Subscriber Identity Module
SOAP	Simple Object Access Protocol
USAT	Universal SIM Application Tool-Kit
USIM	Universal Subscriber Identity Module
VASP	Value Added Service Provider
VHE	Virtual Home Environment
WAP	Wireless Application Protocol

4 Virtual Home Environment

The Virtual Home Environment (VHE) is an important portability concept of the 3G mobile systems. It enables end users to bring with them their personal service environment whilst roaming between networks, and also being independent of terminal used.

The Personal Service Environment (PSE) describes how the user wishes to manage and interact with her communication services. It is a combination of a list of subscribed to services, service preferences and terminal interface preferences. PSE also encompasses the user management of multiple subscriptions, e.g. business and private, multiple terminal types and location preferences. The PSE is defined in terms of one or more User Profiles.

Please see TS 22.121 [5] for more details.

4.1 Personal Service Environment

4.1.1 Void

4.2 Support of Virtual Home Environment Toolkits

4.2.1 USAT

No VHE requirements.

4.2.2 MExE

No VHE requirements.

4.2.3 OSA

4.2.3.1 Support of HE-VASPs

The OSA toolkit may be used by the Home Environment, by Value Added Service Providers (VASPs) and Home Environment Value Added Service Providers (HE-VASPs).

Extensions shall be made to OSA in order to optimize the support of HE-VASPs. These extensions shall use the fact that user subscription information is owned and managed by the home environment, i.e. the Home Environment knows which users are subscribed to the service implemented by the OSA application, and if the service is activated or not.

Specific methods shall be specified in OSA Network Service Capability Features, permitting:

- An OSA application to request user related event notifications pertaining to any subscribed user for which the service implemented by the application is activated.
- The OSA SCS to report user related event notifications in which it explicitly identifies the user to which the event applies.
- An OSA application to request a function to be applied to all current subscribed users for which the service implemented by the application is activated.

It shall also be possible for the OSA SCS to report user related events to the OSA application, without the application having explicitly subscribed to the event (events to be reported have been agreed between the Home Environment and the HE-VASP by other means, e.g. in their service level agreement).

These VHE-specific extensions shall apply to all relevant Network Service Capability Features, like call and session control SCFs, user status, and user location.

4.2.4 CAMEL

No specific requirements in addition to TS 23.078 [2] and TS 22.078 [9].

5 Open Service Access

In order to be able to implement future applications/end user services that are not yet known today, a highly flexible Framework for Services is required. The Open Service Access (OSA) enables applications implementing the services to make use of network functionality. Network functionality offered to applications is defined in terms of a set of Service Capability Features (SCFs). These SCFs provide functionality of network capabilities which is accessible to applications through the standardised OSA interface upon which service developers can rely when designing new services (or enhancements/variants of already existing ones).

The aim of OSA is to provide a standardised, extendible and scalable interface that allows for inclusion of new functionality in the network in future releases with a minimum impact on the applications using the OSA interface.

Network functionality offered to applications is defined as a set of Service Capability Features (SCFs) in the OSA API, which are supported by different Service Capability Servers (SCS). These SCFs provide access to the network capabilities on which the application developers can rely when designing new applications (or enhancements/variants of already existing ones). The different features of the different SCSs can be combined as appropriate. The exact addressing (parameters, type and error values) of these features is described in stage 3 descriptions. These descriptions (defined using OMG Interface Description Language™) are open and accessible to application developers, who can design services in any programming language, while the underlying core network functions use their specific protocols.

The standardised OSA API shall be secure, it is independent of vendor specific solutions and independent of programming languages, operating systems etc used in the service capabilities. Furthermore, the OSA API is independent of the location within the home environment where service capabilities are implemented and independent of supported service capabilities in the network.

To make it possible for application developers to rapidly design new and innovative applications, an architecture with open interfaces is imperative. By using object-oriented techniques, for example CORBA, SOAP, etc., it is possible to use different operating systems and programming languages in application servers and service capability servers. The service capability servers serve as gateways between the network entities and the applications.

The OSA API is based on lower layers using main stream information technology and protocols. The middleware and protocols (for example CORBA/IOP, SOAP/XML, other XML based protocols etc.) and lower layer protocols (for example TCP, IP, etc.) should provide security mechanisms to encrypt data (for example TLS, IP sec, etc.).

5.1 Overview of the Open Service Access

The Open Service Access consists of three parts:

- **Applications:** e.g. VPN, conferencing, location based applications. These applications are implemented in one or more Application Servers;
- **Framework:** providing applications with basic mechanisms that enable them to make use of the service capabilities in the network. Examples of framework functions are Authentication and Discovery. Before an application can use the network functionality made available through Service Capability Features, authentication between the application and framework is needed. After authentication, the discovery function enables the application to find out which network service capability features are provided by the Service Capability Servers. The network service capability features are accessed by the methods defined in the OSA interfaces;
- **Service Capability Servers:** providing the applications with service capability features, which are abstractions from underlying network functionality. Examples of service capability features offered by the Service Capability Servers are Call Control and User Location. Similar service capability features may possibly be provided by more than one Service Capability Server. For example, Call Control functionality might be provided by SCSs on top of CAMEL and MExE.

The OSA service capability features are specified in terms of a number of interfaces and their methods. The interfaces are divided into two groups:

- framework interfaces;
- network interfaces.

NOTE: The CAMEL Service Environment does not provide the service logic execution environment for applications using the OSA API, since these applications are executed in Application Servers.

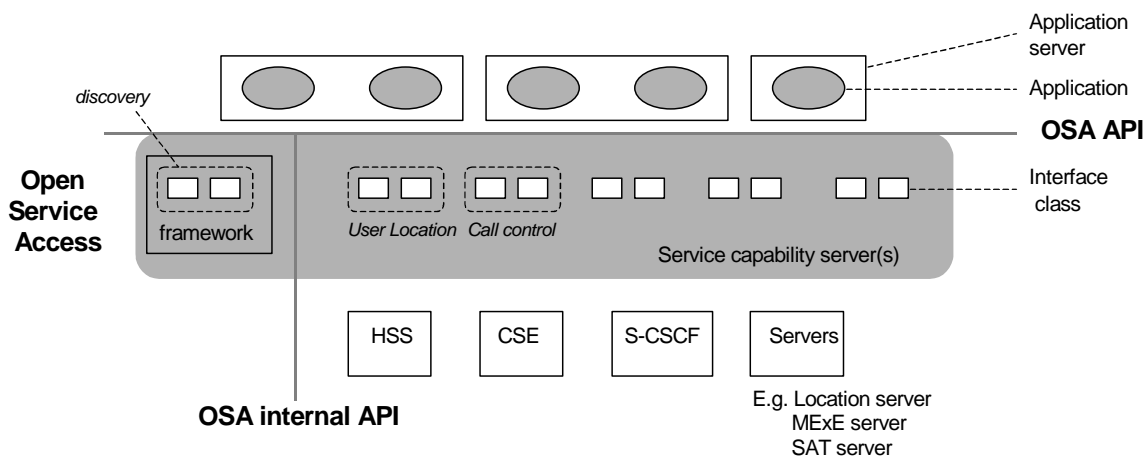

Figure 1: Overview of Open Service Access

The present document, together with the associated stage 3 specification, defines the OSA API and the OSA internal API between the framework and the service capability servers. OSA does not mandate any specific platform or programming language.

The Service Capability Servers that provide the OSA interfaces are functional entities that can be distributed across one or more physical nodes. For example, the User Location interfaces and Call Control interfaces might be implemented on a single physical entity or distributed across different physical entities. Furthermore, a service capability server can be implemented on the same physical node as a network functional entity or in a separate physical node. For example, Call Control interfaces might be implemented on the same physical entity as the CAMEL protocol stack (i.e. in the CSE) or on a different physical entity.

Several options exist:

Option 1

The OSA interfaces are implemented in one or more physical entity, but separate from the physical network entities. Figure 2 shows the case where the OSA interfaces are implemented in one physical entity, called "gateway" in the figure. Figure 3 shows the case where the SCSs are distributed across several "gateways".

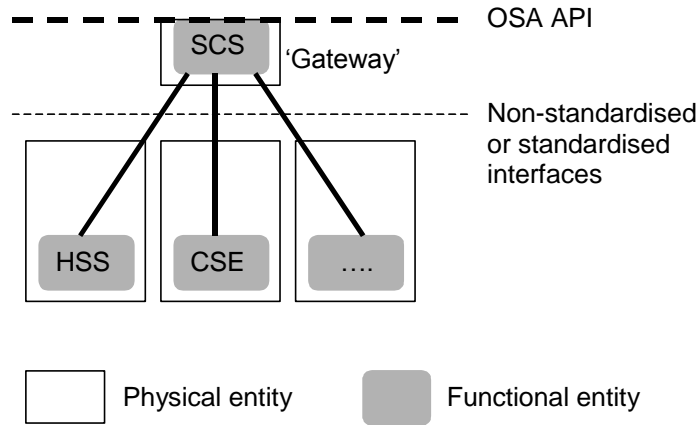

Figure 2: SCSs and network functional entities implemented in separate physical entities

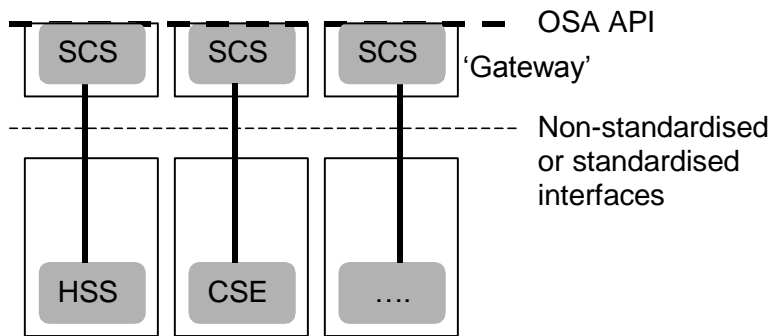

Figure 3: SCSs and network functional entities implemented in separate physical entities, SCSs distributed across several 'gateways'

Option 2

The OSA interfaces are implemented in the same physical entities as the traditional network entities (e.g. HSS, CSE), see figure 4.

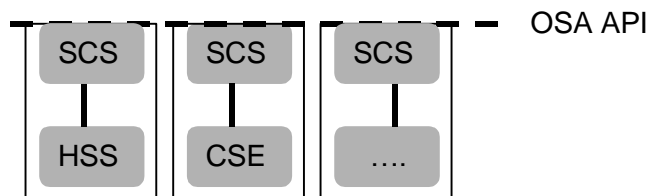

Figure 4: SCSs and network functional entities implemented in same physical entities

Option 3

Option 3 is the combination of option 1 and option 2, i.e. a hybrid solution.

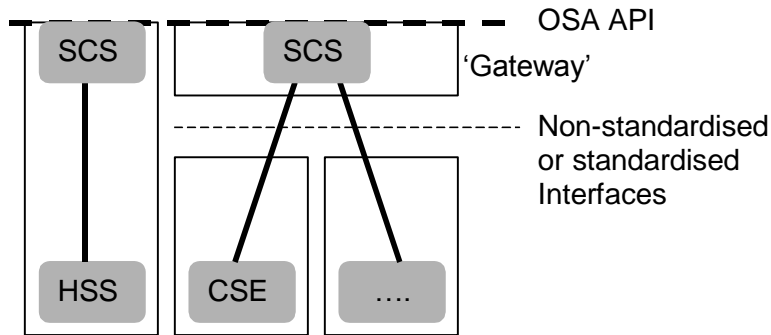

Figure 5: Hybrid implementation (combination of option 1 and 2)

It shall be noted that in all cases there is only one framework. This framework may reside within one of the physical entities containing an SCS or in a separate physical entity.

From the application point of view, it shall make no difference which implementation option is chosen, i.e. in all cases the same network functionality is perceived by the application. The applications shall always be provided with the same set of interfaces and a common access to framework and service capability feature interfaces. It is the framework that will provide the applications with an overview of available service capability features and how to make use of them.

5.2 Basic mechanisms in the Open Service Access

This subclause explains which basic mechanisms are executed in OSA prior to offering and activating applications.

Some of the mechanisms are applied only once (e.g. establishment of service agreement), others are applied each time a user subscription is made to an application (e.g. enabling the call attempt event for a new user).

Basic mechanisms between Application and Framework:

- **Authentication:** Once an off-line service agreement exists, the application can access the authentication function. The authentication model of OSA is a peer-to-peer model. The application must authenticate the framework and vice versa. The application must be authenticated before it is allowed to use any other OSA function.
- **Authorisation:** Authorisation is distinguished from authentication in that authorisation is the action of determining what a previously authenticated application is allowed to do. Authentication must precede authorisation. Once authenticated, an application is authorised to access certain service capability features.
- **Discovery of framework functions and network service capability features:** After successful authentication, applications can obtain available framework functions and use the discovery function to obtain information on authorised network service capability features. The Discovery function can be used at any time after successful authentication.
- **Establishment of service agreement:** Before any application can interact with a network service capability feature, a service agreement must be established. A service agreement may consist of an off-line (e.g. by physically exchanging documents) and an on-line part. The application has to sign the on-line part of the service agreement before it is allowed to access any network service capability feature.
- **Access to network service capability features:** The framework must provide access control functions to authorise the access to service capability features or service data for any API method from an application, with the specified security level, context, domain, etc.

Basic mechanism between Framework and Service Capability Server:

- **Registering of network service capability features.** SCFs offered by a Service Capability Server can be registered at the Framework. In this way the Framework can inform the Applications upon request about available service capability features (Discovery). For example, this mechanism is applied when installing or upgrading a Service Capability Server.

Basic mechanisms between Application Server and Service Capability Server:

- **Request of event notifications.** This mechanism is applied when a user has subscribed to an application and that application needs to be invoked upon receipt of events from the network related to the user. For example, when a user subscribes to an incoming call screening application, the application needs to be invoked when the user receives a call. It will therefore request to be notified when a call setup is performed, with the user number as Called Party Number.

5.3 Handling of end-user related security

Once OSA basic mechanisms have ensured that an application has been authenticated and authorised to use network service capability features, it is important to also handle end-user related security aspects. These aspects consist of the following.

- End-user authorisation to applications, limiting the access of end-users to the applications they are subscribed to.
- Application authorisation to end-users, limiting the usage by applications of network capabilities to authorised (i.e. subscribed) end-users.
- End-user's privacy, allowing the user to set privacy options.

These aspects are addressed in the following subclauses.

5.3.1 End-user authorisation to applications

An end-user is authorised to use an application only when he or she is subscribed to it.

In the case where the end-user has subscribed to the application before the application accesses the network SCFs, then the subscription is part of the Service Level Agreement signed between the HE and the HE-VASP.

After the application has been granted access to network SCFs, subscriptions are controlled by the Home Environment. Depending on the identity of an authenticated and authorised end-user, the Home Environment may use any relevant policy to define and possibly restrict the list of services to which a particular end-user can subscribe. At any time, the Home Environment may decide, unilaterally or after agreement with the HE-VASP, to cancel a particular subscription.

Service subscription and activation information need to be shared between the Home Environment and the HE-VASP, so that the HE-VASP knows which end-users are entitled to use its services. Appropriate online and/or offline synchronisation mechanisms (e.g. SLA re-negotiation) can be used between the HE and the HE-VASP, which are not specified in OSA release 5.

End-to-end interaction between a subscribed end-user and an application may require the usage of appropriate authentication and authorisation mechanisms between the two, which are independent from the OSA API, and therefore not in the scope of OSA standardisation.

5.3.2 Application authorisation to end-users

The Home Environment is entitled to provide service capabilities to an application with regard to a specific end-user if the following conditions are met:

- 1) the end-user is subscribed to the application;
- 2) the end-user has activated the application;
- 3) the usage of this network service capability does not violate the end-users privacy settings (see next subclause).

The service capability server ensures that the above conditions are met whenever an application attempts to use a service capability feature for a given end-user, and to respond to the application accordingly, possibly using relevant error parameters). The mechanism used by the SCS to ensure this is internal to the HE (e.g. access to user profile) and is not standardised in OSA release 5.

5.3.3 End-user's privacy

The Home Environment may permit an end-user to set privacy options. For instance, it may permit the end-user to decide whether his or her location may be provided to 3rd parties, or whether he or she accepts information to be pushed to his or her terminal. Such privacy settings may have an impact on the ability of the network to provide service capability features to applications (e.g. user location, user interaction). Thus, even if an application is authorised to use an SCF and the end-user is subscribed to this application and this application is activated, privacy settings may still prevent the HE from fulfilling an application request.

The service capability server ensures that a given application request does not violate an end-users privacy settings or that the application has relevant privileges to override them (e.g. for emergency reasons). The mechanism used by the SCS to ensure this is internal to the HE and is not standardised in OSA release 5.

6 Framework service capability features

6.1 Trust and Security Management Functions

The Trust and Security Management functions provide:

- the first point of contact for an application to access a Home Environment;
- the authentication methods for the application and Home Environment to perform an authentication protocol;
- the application with the ability to select a network service capability feature to make use of;
- the application with a portal to access other framework functions.

The process by which the application accesses the Home Environment has been separated into 3 stages, each supported by a different framework function:

- 1) Initial Contact with the framework;
- 2) Authentication to the framework;
- 3) Access to framework functions and network service capability features.

6.1.1 Initial Contact

The application gains a reference to the Initial Contact function for the Home Environment that they wish to access. This may be gained through a URL, a Naming or Trading Service or an equivalent service, a *stringified* object reference, etc. At this stage, the application has no guarantee that this is a reference to the Home Environment.

The application uses this reference to initiate the authentication process with the Home Environment.

Initial Contact supports a particular method to allow the authentication process to take place (using the Authentication SCF defined in subclause 6.1.2). This method must be the first invoked by the application. Invocations of other methods will fail until authentication has been successfully completed.

Once the application has authenticated with the provider, it can gain access to other framework functions and network service capability features. This is done by invoking a method, by which the application requests a certain type of access service capability feature. The OSA Access function is defined in subclause 6.1.3.

6.1.2 Authentication

Once the application has made initial contact with the Home Environment, authentication of the application and Home Environment may be required.

The API supports multiple authentication techniques. The procedure used to select an appropriate technique for a given situation is described below. The authentication mechanisms may be supported by cryptographic processes to provide confidentiality, and by digital signatures to ensure integrity. The inclusion of cryptographic processes and digital signatures in the authentication procedure depends on the type of authentication technique selected. In some cases strong authentication may need to be enforced by the Home Environment to prevent misuse of resources. In addition it may be necessary to define the minimum encryption key length that can be used to ensure a high degree of confidentiality.

The application must authenticate with the framework before it is able to use any of the other interfaces supported by the framework. Invocations on other interfaces will fail until authentication has been successfully completed.

6.1.3 OSA Access

This function supports stage 1 requirements related to authorization and service registration.

During an authenticated session accessing the Framework, the application will be able to select and access an instance of a framework function or network service capability feature.

In order to use network SCFs, the application must first be authorised to do so by establishing a service agreement with the Home Environment. The application uses the discovery SCF to retrieve the ID of the network SCF they wish to use. They may then check that they are authorised to use the SCF. The Home Environment is informed that the application wishes to use the SCF. Finally, a service agreement is signed digitally between the two parties.

Establishing a service agreement is a business level transaction, which requires the HE-VASP that owns the application to agree terms for the use of an SCF with the Home Environment. Service agreements can be reached using either off-line or on-line mechanisms. Off-line agreements will be reached outside of the scope of OSA interactions, and so are not described here. However, applications can make use of service agreements that are made off-line. Some Home Environments may only offer off-line mechanisms to reach service agreements.

After a service agreement has been established between the application and the Home Environment domains, the application will be able to make use of this agreement to access the SCF.

6.2 Discovery

Before a network SCF can be discovered, the application must know what "types" of SCFs are supported by the Framework and what "properties" are applicable to each SCF type. Once the HE-VASP finds out the desired set of SCFs supported by the network, it subscribes (a sub-set of) these SCFs using the Subscription framework function. The HE-VASP (or the applications in its domain) can find out the set of SCFs available to it (i.e., the SCFs that it can use).

6.3 Integrity Management functions

6.3.1 Load Manager

The Load Manager function permits to manage the load on both the application and network sides.

The framework API should allow the load to be distributed across multiple machines and across multiple component processes, according to a load balancing policy. The separation of the load balancing mechanism and load balancing policy ensures the flexibility of the load balancing functionality. The load balancing policy identifies what load balancing rules the framework should follow for the specific application. It might specify what action the framework should take as the congestion level changes. For example, some real-time critical applications will want to make sure continuous service is maintained, below a given congestion level, at all costs, whereas other applications will be satisfied with disconnecting and trying again later if the congestion level rises. Clearly, the load balancing policy is related to the QoS level to which the application is subscribed.

6.3.2 Fault Manager

The Fault Manager function is used by the application to inform the framework of events which affect the integrity of the framework and SCFs, and to request information about the integrity of the system.

6.3.3 Heartbeat Management

The Heartbeat Management function allows the initialisation of a heartbeat supervision of the client application. In case of SCF supervision, it is the framework's responsibility to check the health status of the respective SCF.

Since the OSA API is inherently synchronous, the heartbeats themselves are synchronous for efficiency reasons.

6.3.4 OAM

The OAM function is used to query the system date and time. The application and the framework can synchronise the date and time to a certain extent. Accurate time synchronisation is outside the scope of the OSA API.

6.5 Policy Management

Applications shall have the ability to interact with policy-enabled Service Capability Features in a secure manner. Policy Management allows applications to:

- manage the application's policy-related information;
- manage policy event notification;
- collect policy statistics.

Editor's note: Architectural aspects may concern the storage of policies in the network in order to be shared between different SCSs.

7 Network service capability features

Network service capability features are provided to the applications by service capability servers to enable access to network resources.

7.1 Call Control

The Call Control SCF supports stage 1 requirements related to CS call control, IMS session control and call/session charging.

The Call Control network service capability feature supports the following functionality:

- 1) management function for call/session-related issues, e.g. enable or disable call/session-related event notifications.
- 2) call/session control, e.g. route, disconnect.

7.1.1 Mapping of OSA APIs in CS domain

In the CS domain the OSA Call Control SCF may be mapped to CAP and MAP protocols.

7.1.2 Mapping of OSA APIs in IMS

OSA SCS is one of the three types of "application servers" communicating with S-CSCF in the IMS [8]. OSA Application Server is connected by OSA API to OSA Service Capability Server (SCS) that is connected through ISC interface to S-CSCF and through Sh interface to HSS. ISC interface is based on the use of SIP protocol, see TS 23.218 [10]. The details and functionality of the Sh interface are for further study in TS 23.228 [8].

OSA functions for IMS session control are supported by the following entities:

- The Serving-CSCF (S-CSCF), which performs session control services for an originating or terminating party.
- The Media Resource Function (MRF), which performs conference control and media control functions for multiparty multimedia sessions.

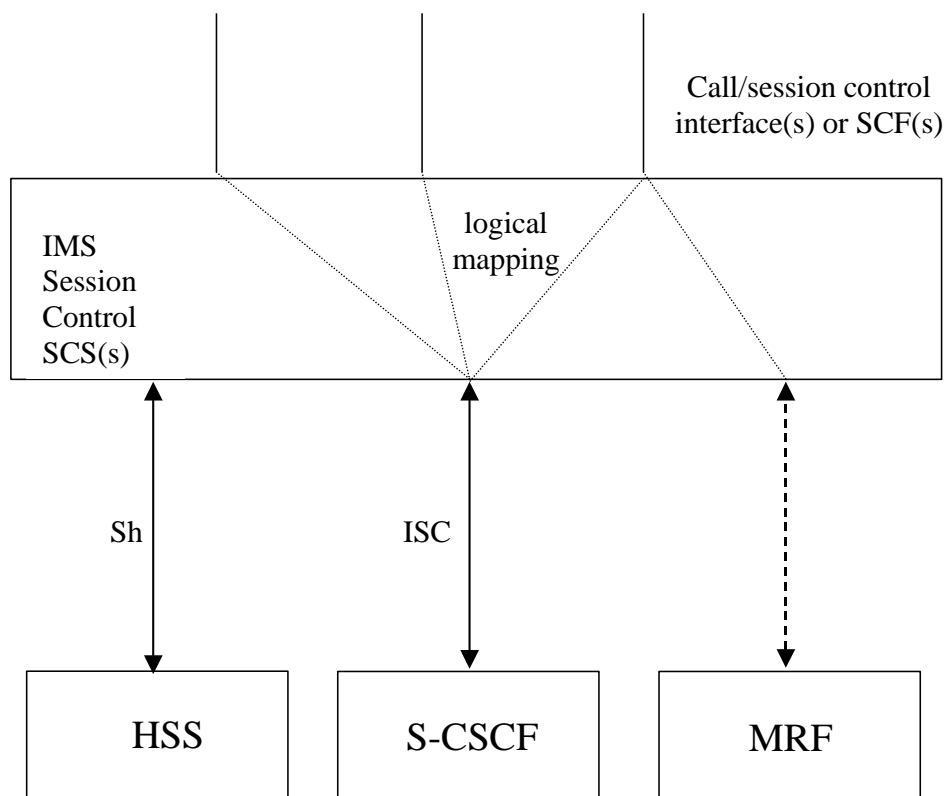

Figure 6: Mapping of OSA IMS session control on the IMS

The stage 3 specification of OSA for IMS session control shall take into account this distribution of responsibilities between the S-CSCF and the MRF, by specifying specific OSA SCF(s) or interface(s) for the S-CSCF, and specific OSA SCF(s) or interface(s) for the MRF. This is to permit clear mapping of OSA on the corresponding entities' functionality, as well as allowing multivendorship.

IMS session control SCF(s) or interface(s) applicable to the S-CSCF shall be mapped onto the IMS Service Control (ISC).

The MRF is either controlled by the OSA SCS by (1) using SIP 3rd party call control via the S-CSCF or (2) using a direct interface to the MRF. These two options are still under investigation.

TS 22.127 [7] classifies IMS session control functions as follows:

- session control requirements;
- media control requirements;
- information requirements.

IMS session control SCF(s) or interface(s) applicable to the S-CSCF shall support session control and information requirements applicable to the originating or terminating party of 2-party session.

These OSA SCF(s) or interface(s) and their implementation shall take into account that the S-CSCF:

- Is an entity that is dynamically associated to the user when she registers to the IMS;
- May behave as a SIP registrar, proxy server, and user agent;
- May receive the request from a session party to initiate an ad-hoc conference (to be associated to an MRF);
- May generate CDRs.

IMS session control SCF(s) or interface(s) applicable to the MRF shall support all session control, media control, and information requirements.

These OSA SCF(s) or interface(s) and their implementations shall take into account that the MRF:

- May support both ad-hoc and pre-arranged conferences;
- Controls media stream resources associated to the conference;
- Behaves as a SIP user agent with regard to each party of the conference;
- Supports conference booking and floor control;
- Is divided into Media Resource Function Controller (MRFC) and Media Resource Function Protocol (MRFP), which interface via an H.248 fully compliant interface.

7.2 Data Session Control

The Data Session Control SCF supports stage 1 requirements related to PS call control.

The Data Session Control network service capability feature supports the following functionality:

- 1) management functions for data session related issues, e.g. enable or disable data session-related event notifications
- 2) session control, e.g. route, disconnect.

7.3 Mobility

The Mobility SCF addresses stage 1 requirements for user location and user status based on network-related information.

The Mobility SCF provides terminal location information and general terminal status monitoring. The following information is reported when requested provided that the network is able to support the corresponding capability:

- user whom the report concerns;
- VLR number;
- Cell Global Identification or Location Area Identification;

- location number (network specific, refer to ITU-T Q.763);
- geographical location (e.g. in terms of universal latitude and longitude co-ordinates);
- accuracy (value depending on local regulatory requirements and level of support in serving/home networks; note that the accuracy of the serving network might differ from that in the home environment);
- age of location information (last known date/time made available in GMT);
- status of the user's terminal.

Connection of an external LCS client by means of OSA API to GMLC is shown in TS 23.271 [13], figure 6.1: General arrangement of LCS.

An application uses the Mobility SCF to perform the following:

- user location requests;
- requests for starting (or stopping) the generation by the network of periodic user location reports;
- requests for starting (or stopping) the generation by the network of user location reports based on location changes;
- report of location information;
- notification of location update.

The application can also for each user start/stop receipt of notifications and modify the required accuracy by selecting another option from the network provided options.

7.4 Terminal Capabilities

The Terminal Capabilities SCF provides applications information about the terminal capabilities of the user. It shall be possible for an application to request Terminal Capabilities as defined by MExE (MExE User Profile) [1]. The terminal capabilities are provided by a MExE compliant terminal to the MExE Service Environment either on request or by the terminal itself.

Terminal Capabilities are available only after a capability negotiation has previously taken place between the user's MExE terminal and the MExE Service environment as specified in [1].

NOTE: For Release 5 only WAP and MExE devices can supply terminal capabilities.

7.5 User Interaction

The User Interaction SCFs support stage 1 requirements for information transfer.

There are two user interaction SCFs:

- Generic User Interaction: used by applications to interact with end users;
- Call User Interaction: used by applications to interact with end users participating to a call.

7.6 [void]

7.7 Charging

The Charging SCF addresses stage 1 requirements for charging related to service usage (and not call/session control).

This SCF permits an application to access subscriber accounts maintained by the network and charge subscribers for service usage.

Provided, that these functions are supported by the underlying network an application providing a service to the subscriber can use the Charging SCF to:

- Check, if – for the service to be provided by the application – the charge is covered by the subscribers account or credit limit.
- Reserve – for the service to be provided by the application – a charge in the subscribers account, that can be deducted from the account after service delivery.
- Deduct an amount from the subscriber's account.
- Release a reservation acquired earlier.
- Add non-monetary units to a subscriber's account.
- Deduct non-monetary units from a subscriber's account.

Reverse a completed charge transaction, e.g. after repudiation.

7.8 Account Management

The Account Management SCF addresses stage 1 requirements related to the features to monitor subscriber's account:

- retrieval of transaction history for a certain subscriber's account;
- query of the balance of the account of one or several subscriber's;
- request of notifications on certain criteria for one or several subscribers.

7.9 Presence

The Presence SCF addresses stage 1 requirements on presence related capability functions.

OSA shall allow an application access to presence capabilities within the network. Presence related information may be requested or supplied by an OSA application and may include, but not be limited to presence information pertaining to the presence service or user availability. Presence information, i.e. a set of attributes characterising current properties of a presentity, is described in TS 22.141 [11].

An OSA application shall be able:

- to register as a watcher, to request a presentity's presence information and to be notified of changes in the presence information.
- to register as a presentity, to publish presence information, to retrieve watcher information and to manage related parameters (e.g. access rules). Presence management may include the setting of user preferences, the update of access rules...etc.

7.9.1 Mapping of OSA APIs

The Presence OSA APIs can be mapped to reference points Peu and Pw of the Presence Server.

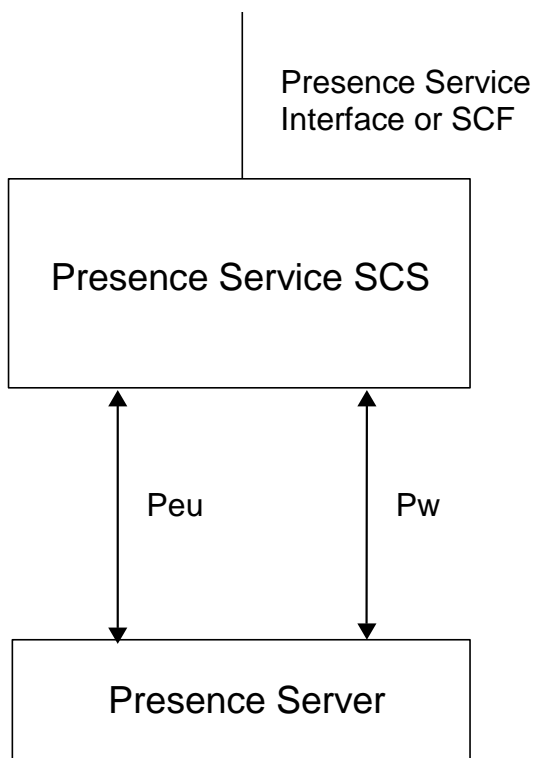

Figure 7: Mapping of OSA Presence APIs

Reference points Peu (i.e. between a Presence User Agent and the Presence Server) and Pw (i.e. between Watcher Applications and the Presence Server) are described in TS 23.141 [14].

7.10 [void]

7.11 [void]

8 OSA Internal API

The OSA internal API between framework and service capability servers (SCSs) supports registering of network service capability features (SCFs), permits the framework to retrieve a network SCF manager interface when an application is granted access to a network SCF, and enables integrity management by means of load management, heartbeat management and fault management.

8.1 OSA Access and Discovery

To support registration, the OSA Access and Discovery interfaces shall be supported at the OSA internal API.

8.2 Registration of network service capability features at the framework

The Framework needs to know the Service Capability Features provided by the SCSs, in order to make them available to applications. For this purpose network service capability features have to be registered with the Framework, and they need to be registered in such a way that applications can discover them.

NOTE: Framework and Service Capability Servers are located within the same trusted domain. Therefore no authentication mechanisms are required between them.

8.2.1 Service Registration

The Service Registration interface provides the methods used for the registration of network SCFs at the framework.

8.2.2 Service Factory

The Service Factory interface allows the framework to get access to a manager interface of a network SCF. It is used, in order to return an SCF manager interface reference to the application. Each SCF has a manager interface that is the initial point of contact for the network SCF.

8.3 Integrity Management

Integrity Management interfaces allow the framework to perform load management, heartbeat management and fault management.

8.3.1 Load Management

Load management enables the framework to manage the load allowing it to be distributed across multiple SCFs by means of load balancing.

8.3.2 Heartbeat Management

Heartbeat management allows the initialisation of a heartbeat supervision of a network SCF.

8.3.3 Fault Management

Fault management allows to inform the framework of events which affect the integrity of the framework and network SCFs, and to request information about the integrity of the system.

9 Parlay X Web Services: OSA at a higher level of abstraction

9.1 General

The general architecture of a solution including Web Services and/or OSA links in deployment allows a number of deployment configurations. These configurations are derivatives of a basic architecture model, enabling a variety of deployment options.

A typical Parlay X Web Services deployment model is shown in the Figure 9.1. This model shows the publication of Parlay X Web Services through a registry, making those Web Services available for discovery, and for applications to use Web Services access methods to interact with the Gateway, where the Web Service interfaces are implemented.

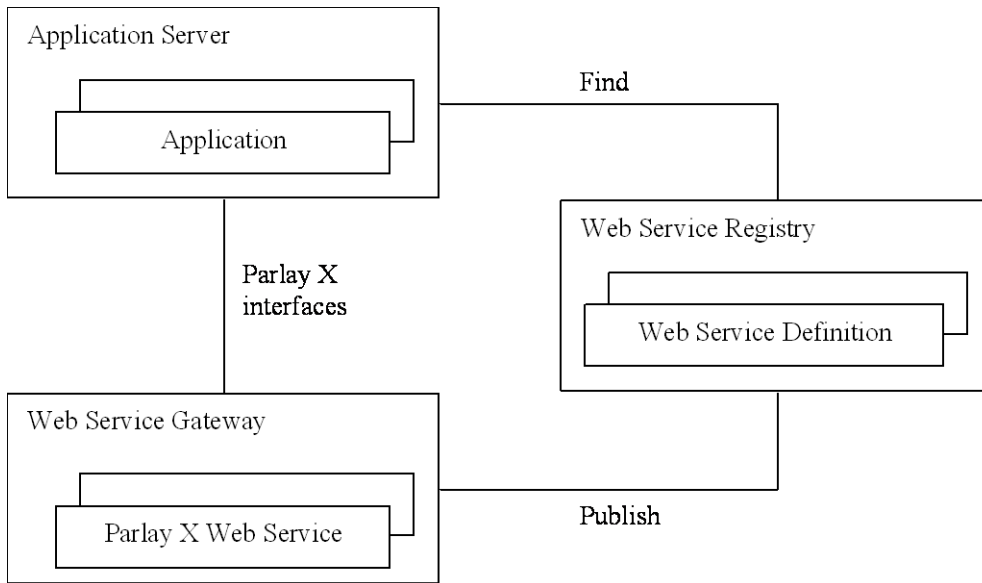

Figure 9.1 Parlay X Web Services deployment model

Interfaces to the Web Services Registry are drawn in Figure 9.1 for consistency with Web Service architectures, but they are not in the scope of the Parlay X Web Services.

This architecture may be combined with existing OSA deployment configurations, providing the overall architecture as illustrated in Figure 9.2.

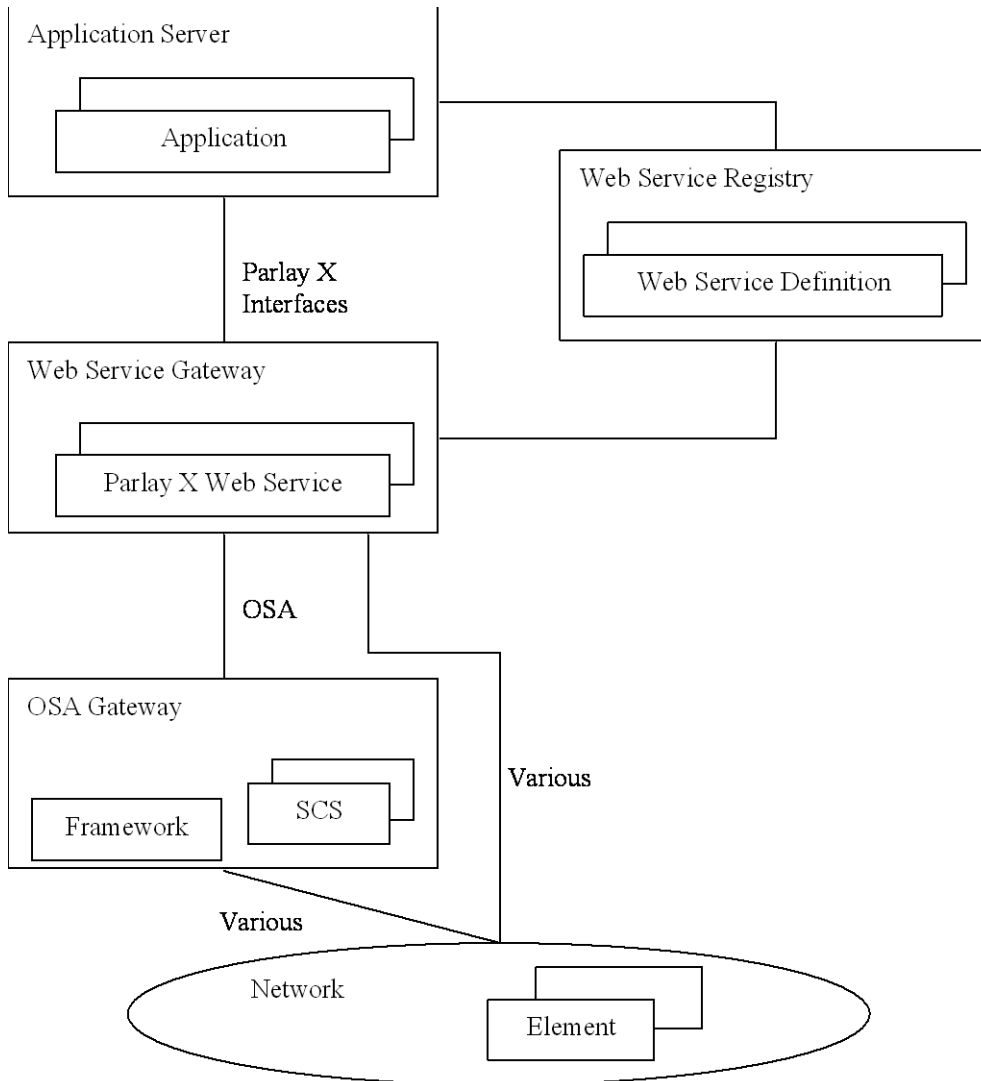

Figure 9.2 The overall Parlay X Web Services architecture

9.1.1 Deployment Scenario A: Web Services to OSA

This scenario addresses solutions that combine Web Services interfaces facing the exterior of the network with OSA interfaces facing the interior of the network.

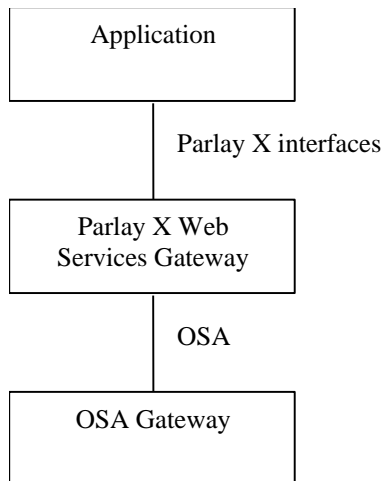

Figure 9.3 Deployment Scenario A: Web Services to OSA

Environment Description

The Application will utilize Web Services to discover and interact with the network, and will not have visibility to the OSA implementation behind the Parlay X Web Services Gateway. The Parlay X Web Services Gateway attaches to the OSA Gateway through an OSA interface. The information published to the Web Services Registry provides the Application with the connection information required to connect with the Parlay X Web Services Gateway.

9.1.2 Deployment Scenario B: Web Services to Network Element

This scenario addresses solutions that combine Web Services interfaces facing the exterior of the network with network element specific interfaces facing the interior of the network.

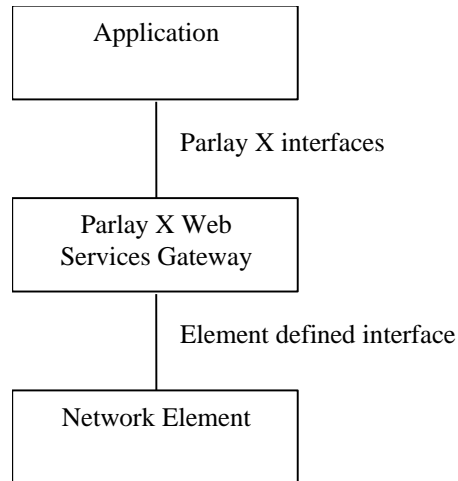

Figure 9.4 Deployment Scenario B: Web Services to Network Element

Environment Description

The Application will utilize Web Services to discover and interact with the network, and will not have visibility to the implementation behind the Parlay X Web Services Gateway. The Parlay X Web Services Gateway attaches to the Network Element through an interface defined by the Network Element. These interfaces (i.e. Element defined interface) are not in the scope of this specification. The information published to the Web Services Registry provides the Application with the connection information required to connect with the Parlay X Web Services Gateway.

The next sections describe the Web Services supported by OSA Rel6.

9.2 Third Party Call

This Web Service supports the functionality to create and manage a call initiated by an application (third party call). Using the Third Party Call Web Service, applications can invoke call handling functions without detailed telecommunication knowledge. The functionality provided is:

- Make a call which sets up a call between two addresses
- Get call information gives information about how the call progressed in the network
- End call will cease the call
- Cancel Call Request allows the network to prevent call setup before completion

9.3 Network-Initiated Third Party Call

These functions are for handling calls initiated by a subscriber in the network. A (third party) application determines how the call should be treated. The overall scope of this Web service is to provide simple functions to application developers to determine how a call should be treated. Using the Network-Initiated Third Party Call Web Service,

application developers can perform simple handling of network-initiated calls without specific Telco knowledge. The Web services allow the application to handle the following conditions occurring in the set-up of a call:

- Destination busy
- Address is not Reachable
- Destination is not answering
- A specific number has been called by subscriber
- The subscriber has taken the terminal "off-hook"

9.4 SMS

The overall scope of this Web Service is to provide to applications the means to handle SMS in a simple way. For receiving a message from the network, the application may use either polling or notification mechanisms. The notification mechanism is more common: network-initiated messages are sent to autonomous application-side web services. Both mechanisms are supported, but the provisioning of the notification-related criteria is not specified. Services are specified to enable an application to:

- Send any SMS
- Send a logo embodied in an SMS
- Send a ringtone embodied in an SMS
- Retrieve the delivery status of an SMS
- Request to be notified of received SMSs
- Retrieve SMS messages sent to an address

9.5 Multimedia Message

This is additional to the SMS web services and handles more general messaging case. Multimedia Message services provide generic messaging features (including SMS) to send and receive messages. For receiving a message from the network the application may use either polling or notification mechanisms. Network-initiated messages are sent to autonomous application-side web services. The following functions are supported:

- Send a message to an address
- Retrieve the delivery status of a message
- Retrieve by polling for received messages
- Retrieve message parts by URI references
- Retrieve whole messages as SOAP attachments
- Notification to the application that a message has been received for a specific address

9.6 Payment

The Payment Web Services support payment reservation, pre-paid payments, and post-paid payments. They support charging of both volume and currency amounts, a conversion function, and a settlement function in case of a financially resolved dispute. The functions supported enable the application to:

- Charge/refund an account by a currency amount
- Charge/refund an account by volume (e.g. minutes)
- Calculate a currency amount from a volume for a specific account

- Reserve a currency amount on an account
- Charge a prior reservation to the account
- Release a reservation by returning to an account the amount remaining in a reservation
- Reserve a volume amount of an account

9.7 Account Management

The Parlay X Account Management supports account querying, direct recharging and recharging through vouchers. The application can manage various aspects of an account using the functionality to:

Return the currency balance on an account

- Request what date the credit on an account is due to expire
- Update the currency/account balance on an account
- Return the transaction history on an account

9.8 User Status

The Parlay X User Status Web Service is used for getting user status information. The functionality supported is simple:

- Requests a user's status subject to the user's policies.

9.9 Terminal Location

The Parlay X Terminal Location Web Service is used for getting location information, it does not require specific telecommunication skills, but a knowledge of location co-ordinates is required. One service is specified to:

Request the location of one terminal subject to user's privacy policies.

Annex A (informative): Change History

Change history					
TSG SA #	Version	CR	Tdoc SA	New Version	Subject/Comment
SA_09	3.1.0	012	SP-000452	3.2.0	CR on Parlay-OSA alignment: basic service interface
SA_09	3.1.0	013	SP-000452	3.2.0	CR on Parlay-OSA alignment: initial contact interfaces
SA_09	3.1.0	014	SP-000452	3.2.0	CR on Parlay-OSA alignment : access SCF
SA_09	3.1.0	015	SP-000452	3.2.0	CR on Parlay-OSA alignment: load manager SCF
SA_09	3.1.0	016	SP-000452	3.2.0	CR on Parlay-OSA alignment: fault manager SCF
SA_09	3.1.0	017	SP-000452	3.2.0	CR on Parlay-OSA alignment: servicefactory SCF
SA_09	3.1.0	018	SP-000452	3.2.0	CR on Parlay-OSA alignment: authentication interface
SA_09	3.2.0	011r1	SP-000452	4.0.0	Change of TS 23.127 title for version 4.0.0 and up
SA_11	4.0.0	020	SP-010118	4.1.0	Alignment of 23.127 due to transfer of stage 3 content to 29.198
SA_11	4.0.0	021	SP-010118	4.1.0	Alignment due to additional Release 4 capabilities.
SA_12	4.1.0	026	SP-010332	4.2.0	CR on addition of transport examples in addition to CORBA
SA_14	4.2.0	027r1	SP-010710	5.0.0	CR on creation of VHE Stage 2 for Release 5 and change of name to include "OSA" in title
SA-15	5.0.0	032	SP-020133	5.1.0	OSA Internal API, Integrity Management
SA-15	5.0.0	034r1	SP-020133	5.1.0	Refinement of OSA Mobility SCF
SA-15	5.0.0	035r1	SP-020133	5.1.0	Correction in Mobility SCF definition
SA-15	5.0.0	037r1	SP-020133	5.1.0	Mapping of OSA API-s to Presence
SA-16	5.1.0	041r1	SP-020314	5.2.0	Removal of Mapping of Presence OSA APIs
SA-16	5.1.0	042r1	SP-020314	5.2.0	Proposal to remove the feature "Retrieval of visited network capabilities"
SA-16	5.1.0	043r1	SP-020314	5.2.0	Reduction of scope of OSA Rel5
SA-18	5.2.0	044	SP-020777	6.0.0	Mapping of OSA APIs to Presence
SA-24	6.0.0	047r1	SP-040315	6.1.0	Add descriptions of OSA high-level abstraction interfaces