

3GPP TS 23.081 V11.0.0 (2011-12)

Technical Specification

**3rd Generation Partnership Project;
Technical Specification Group Core Network and Terminals;
Line identification supplementary services;
Stage 2
(Release 11)**



The present document has been developed within the 3rd Generation Partnership Project (3GPPTM) and may be further elaborated for the purposes of 3GPP.

The present document has not been subject to any approval process by the 3GPP Organisational Partners and shall not be implemented. This Specification is provided for future development work within 3GPP only. The Organisational Partners accept no liability for any use of this Specification.

Specifications and reports for implementation of the 3GPPTM system should be obtained via the 3GPP Organisational Partners' Publications Offices.

Keywords

GSM, UMTS, network, CLIP, CLIR, COLP, COLR,
supplementary service, stage 2

3GPP

Postal address

3GPP support office address

650 Route des Lucioles - Sophia Antipolis
Valbonne - FRANCE
Tel.: +33 4 92 94 42 00 Fax: +33 4 93 65 47 16

Internet

<http://www.3gpp.org>

Copyright Notification

No part may be reproduced except as authorized by written permission.
The copyright and the foregoing restriction extend to reproduction in all media.

© 2011, 3GPP Organizational Partners (ARIB, ATIS, CCSA, ETSI, TTA, TTC).
All rights reserved.

UMTS™ is a Trade Mark of ETSI registered for the benefit of its members

3GPP™ is a Trade Mark of ETSI registered for the benefit of its Members and of the 3GPP Organizational Partners

LTE™ is a Trade Mark of ETSI currently being registered for the benefit of its Members and of the 3GPP Organizational Partners
GSM® and the GSM logo are registered and owned by the GSM Association

Contents

Foreword	5
0 Scope	6
0.1 References	6
0.2 Definitions and abbreviations	6
0.2.1 Definitions	6
0.2.1.1 Definition of line identity	6
0.2.1.2 Definition of presentation and screening indicators	7
0.2.2 Abbreviations	7
1 Calling line identification presentation (CLIP)	7
1.1 Handling of calling line identification presentation	7
1.1.1 Interrogation	7
1.2 Functions and information flows	8
1.2.1 Optional capability to carry calling line identification	17
1.2.2 Information elements used in the messages	17
1.2.3 Parameters in Send Routeing Info and Provide Roaming Number for CLI	18
1.2.4 Messages between MSC and VLR in destination network	19
1.3 Information stored in the HLR	19
1.4 State transition model	19
1.5 Transfer of information from HLR to VLR	20
1.6 Information stored in the VLR	20
1.7 Handover	20
1.8 Interactions with other supplementary services	20
2 Calling line identification restriction (CLIR)	20
2.1 Handling of calling line identification restriction	20
2.1.1 General	20
2.1.2 Permanent mode	21
2.1.3 Controlling presentation of the CLI when CLIR is provisioned in temporary mode	21
2.1.4 Interrogation	21
2.2 Functions and information flows	22
2.3 Information stored in the HLR	28
2.4 State transition model	28
2.5 Transfer of information from HLR to VLR	28
2.6 Information stored in the VLR	28
2.7 Handover	29
2.8 Interworking	29
3 Connected line identification presentation (COLP)	29
3.1 Handling of connected line identification presentation	29
3.1.1 Interrogation	29
3.1.2 Interactions with call forwarding supplementary services	30
3.2 Functions and information flows	30
3.3 Information stored in the HLR	35
3.4 State transition model	35
3.5 Transfer of information from HLR to VLR	35
3.6 Information stored in the VLR	36
3.7 Handover	36
4 Connected line identification restriction (COLR)	36
4.1 Handling of connected line identification restriction	36
4.1.1 General	36
4.1.2 Interrogation	36
4.2 Functions and information flows	37
4.3 Information stored in the HLR	40

4.4	State transition model.....	40
4.5	Transfer of information from HLR to VLR.....	41
4.6	Information stored in the VLR.....	41
4.7	Handover.....	41
4.8	Interworking.....	41
Annex A (informative):	Mapping of CLI	42
Annex B (informative):	Change history.....	44

Foreword

This Technical Specification has been produced by the 3GPP.

This TS defines the stage 2 of the line identification supplementary services for the 3GPP system.

The contents of the present document are subject to continuing work within the TSG and may change following formal TSG approval. Should the TSG modify the contents of this TS, it will be re-released by the TSG with an identifying change of release date and an increase in version number as follows:

Version 3.y.z

where:

- x the first digit:
 - 1 presented to TSG for information;
 - 2 presented to TSG for approval;
 - 3 Indicates TSG approved document under change control.
- y the second digit is incremented for all changes of substance, i.e. technical enhancements, corrections, updates, etc.
- z the third digit is incremented when editorial only changes have been incorporated in the specification;

0 Scope

The present document gives the stage 2 description of the call identification supplementary services.

The group line identification supplementary services are divided into the following four supplementary services:

- Calling line identification presentation CLIP (clause 1);
- Calling line identification restriction CLIR (clause 2);
- Connected line identification presentation COLP (clause 3);
- Connected line identification restriction COLR (clause 4).

0.1 References

The following documents contain provisions which, through reference in this text, constitute provisions of the present document.

- References are either specific (identified by date of publication, edition number, version number, etc.) or non-specific.
- For a specific reference, subsequent revisions do not apply.
- For a non-specific reference, the latest version applies. In the case of a reference to a 3GPP document (including a GSM document), a non-specific reference implicitly refers to the latest version of that document *in the same Release as the present document*.

- [1] 3GPP TS 21.905: "3G Vocabulary".
- [2] 3GPP TS 23.011: "Technical Realization of Supplementary Services - General Aspects".
- [3] 3GPP TS 23.018 : "Basic Call Handling; Technical realization".
- [4] 3GPP TS 22.081: "Line Identification supplementary services - Stage 1".

0.2 Definitions and abbreviations

0.2.1 Definitions

0.2.1.1 Definition of line identity

The line identity is made up of the following information units:

- The subscriber's international ISDN/MSISDN number;
- Optionally subaddress information.

For mobile originated calls, the ISDN/MSISDN shall always be provided within the network. The subaddress shall only be included if it is provided by the user (or user equipment).

The calling line identity is the line identity of the calling party. The connected line identity is the line identity of the connected party.

The additional calling line identity provides additional line information for the purpose of the calling line identification presentation service (CLIP). The additional connected line identity provides additional line information for the purpose of the connected line identification presentation service (COLP).

For mobile originating calls the user (or user equipment) has no possibility to provide an additional line identity. For mobile terminating calls the user (or user equipment) has no possibility to provide an additional connected line identity.

0.2.1.2 Definition of presentation and screening indicators

In addition to, or instead of, the line identity or additional line identity, the network may send a presentation indicator (PI) together with a Cause of no CLI (CoNC) and/or a screening indicator (SI) to the MS as follows:

- Presentation Indicator:
 - a) Presentation allowed;
 - b) Presentation restricted;
 - c) Number not available.
- If the Presentation Indicator indicates "presentation restricted" the Cause of no CLI may give a diagnostic:
 - a) Unavailable;
 - b) Rejected by user;
 - c) Interaction with other services;
 - d) Coin line/ Pay phone.
- Screening indicator:
 - a) User provided, verified and passed;
 - b) User provided, not screened;
 - c) network provided.

The screening indicator applies to the ISDN/MSISDN or the number given as additional line identity respectively.

0.2.2 Abbreviations

Abbreviations used in the present document are listed in 3GPP TR 21.905.

1 Calling line identification presentation (CLIP)

1.1 Handling of calling line identification presentation

1.1.1 Interrogation

Status check

The mobile subscriber can request the status of the supplementary service and be informed if the service is provided to him/her. This procedure is illustrated in figure 1.1.

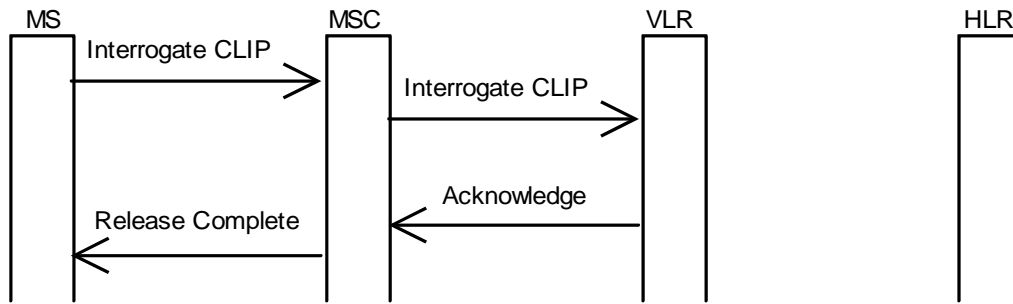

Figure 1.1: Interrogation of calling line identification presentation

1.2 Functions and information flows

The following Mobile Additional Functions have been identified for the PLMN:

MAF001

Determination of the calling line identification presentation subscription

The ability of a PLMN component to determine whether the supplementary service is provisioned for the mobile subscriber. See figure 1.2.

Location: VLR.

MAF002

Determination of the calling party number for offering to the called party

The ability of a PLMN component to determine and to forward the calling line identity and related indications to the called party. See figure 1.3.

Location: destination MSC.

The information flow is shown in figure 1.9.

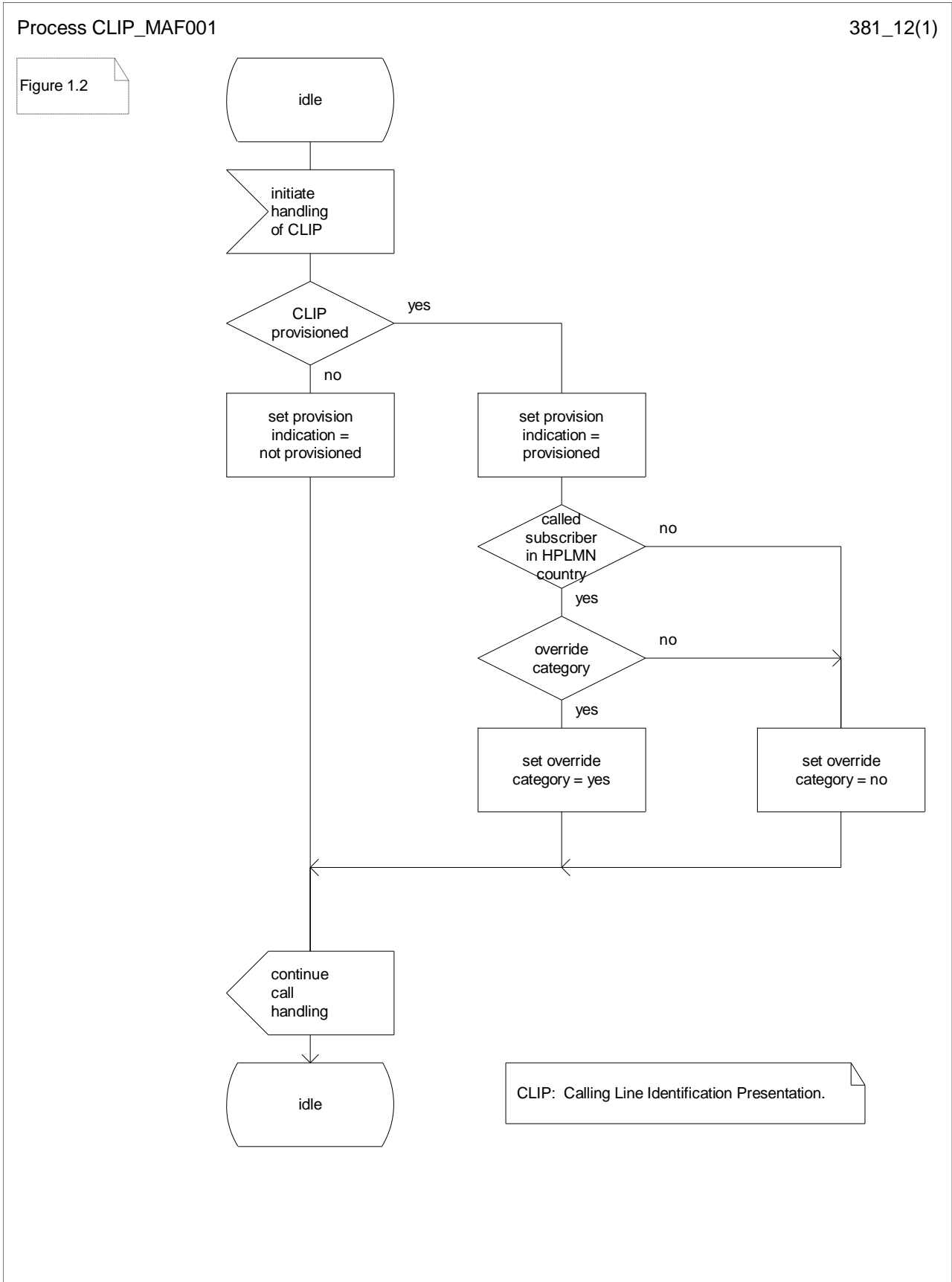

Figure 1.2: MAF001 Determination of calling line identification presentation subscription (VLR)

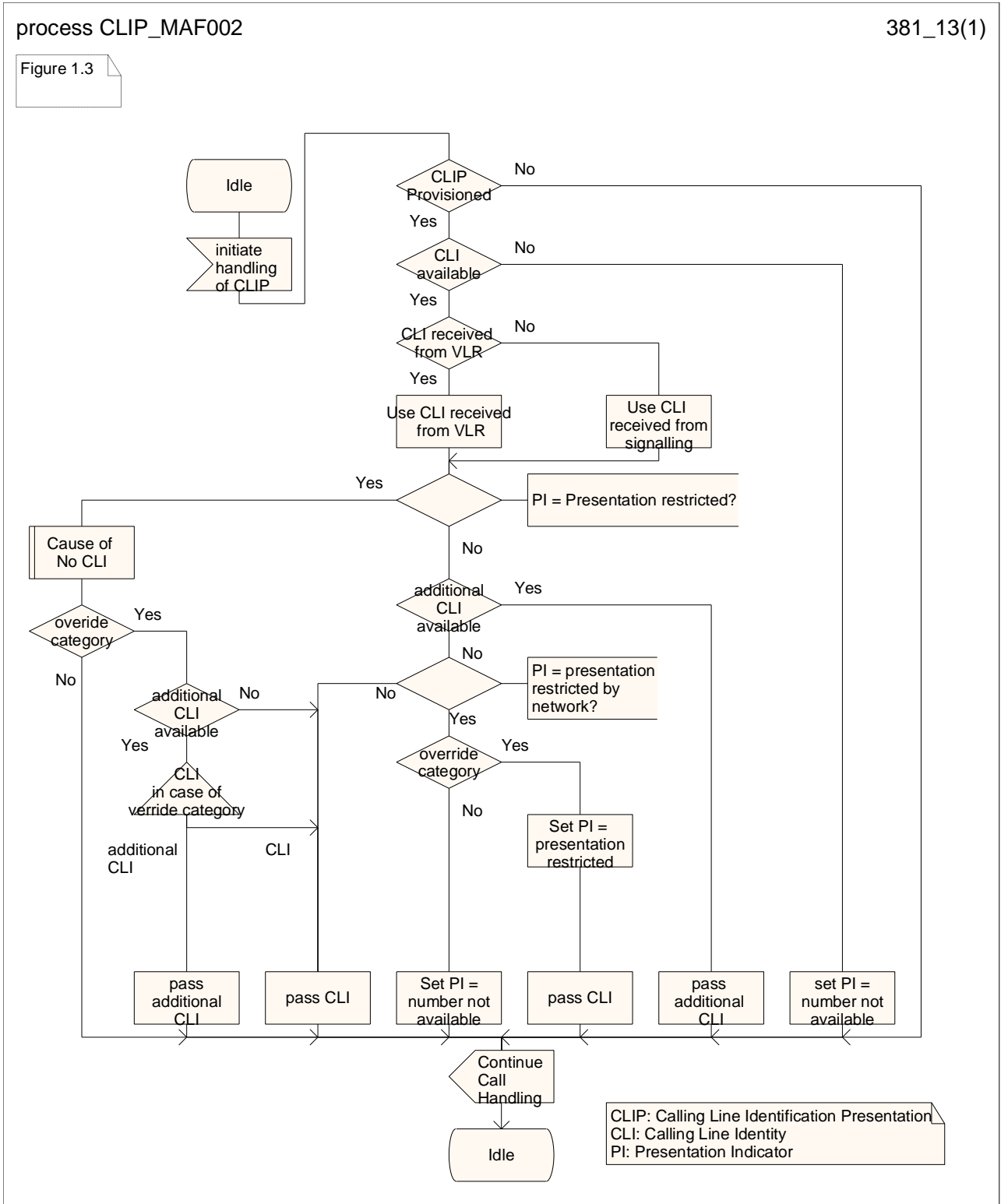

Figure 1.3: MAF002 Determination of the information for offering to the called party (destination MSC)

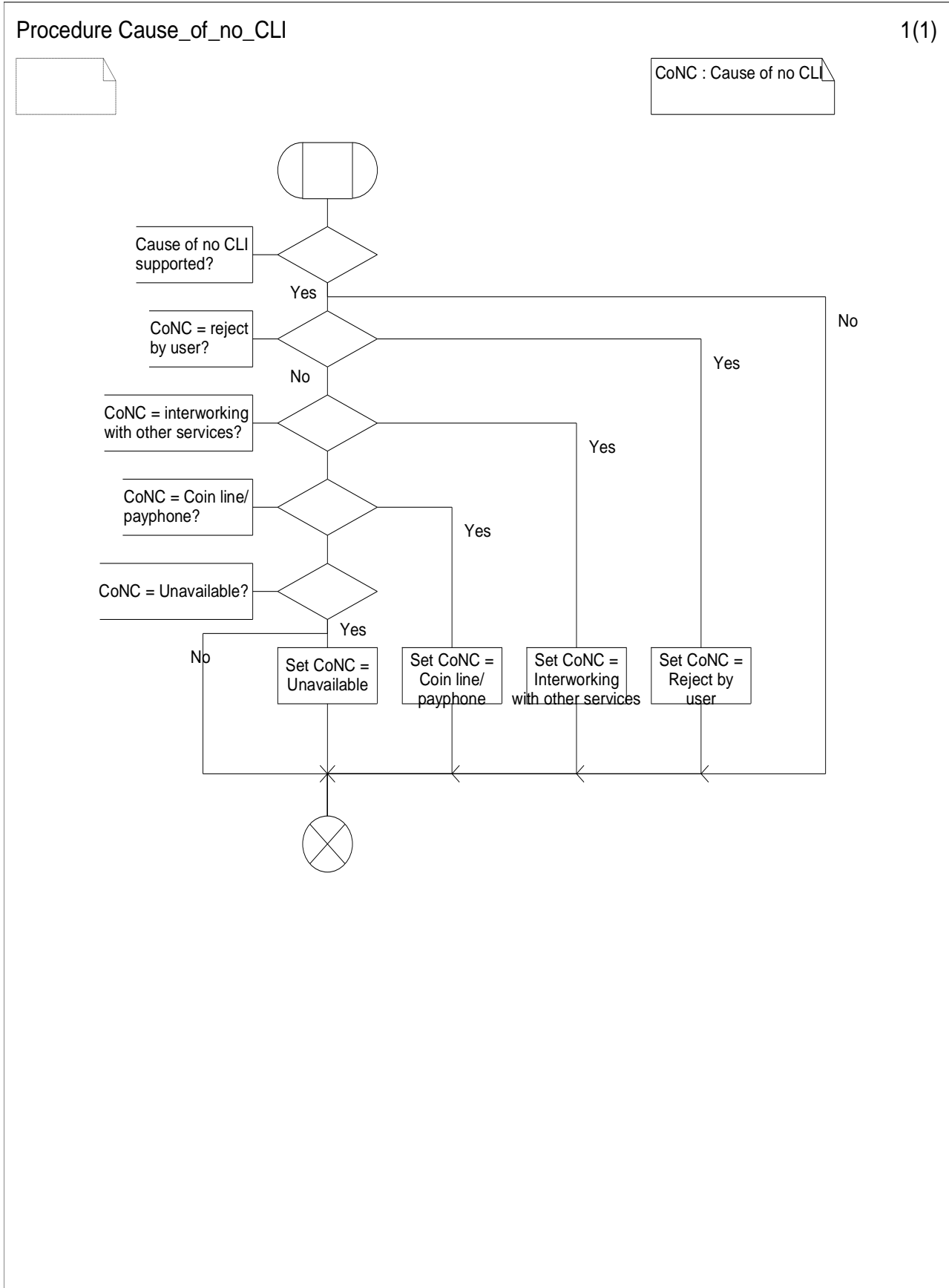

Figure 1.4: Procedure Cause_of_no_CLI

Procedure CLI_MT_GMSC

1(1)

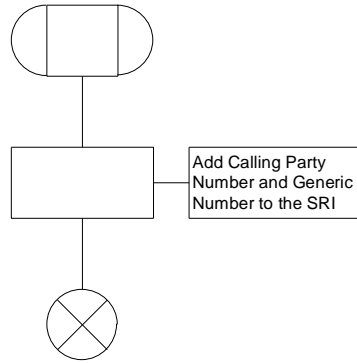

Figure 1.5: Addition of line identification information to Send Routeing Info message.

Procedure CLI_HLR_Set_CLI

1(1)

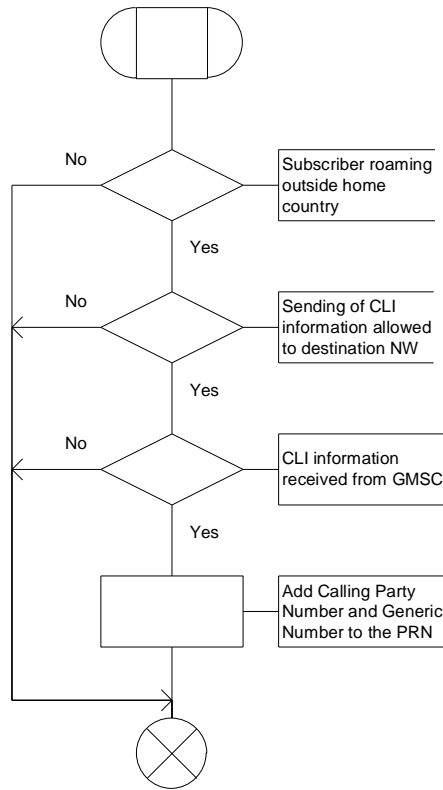

Figure 1.6: Addition of line identification information to Provide Roaming Number message.

Procedure CLI_PRN_VLR

1(1)

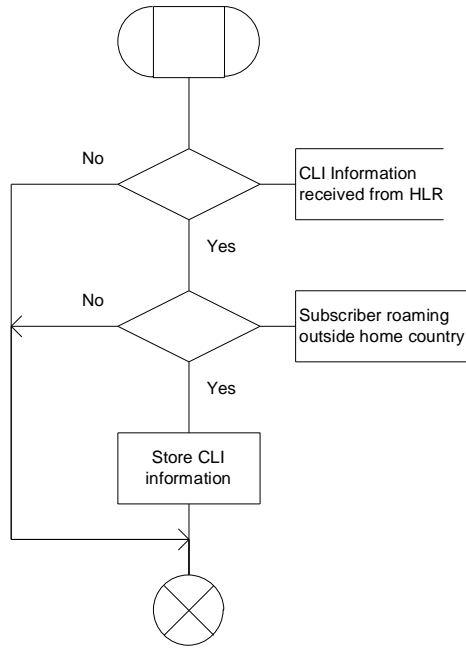

Figure 1.7: Storing of Line Identification in destination VLR

Procedure CLI_ICH_VLR_Add_CLI

1(1)

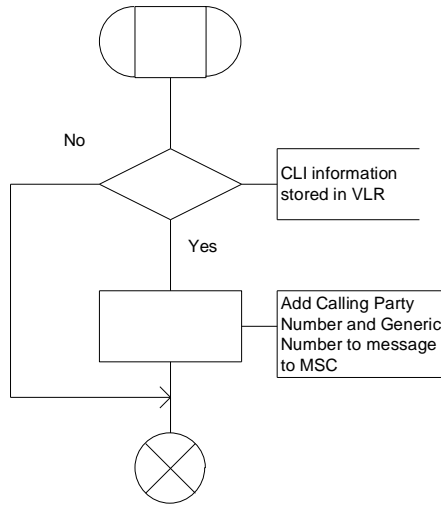

Figure 1.8: Addition of line identification information to Complete Call/Process Call Waiting message.

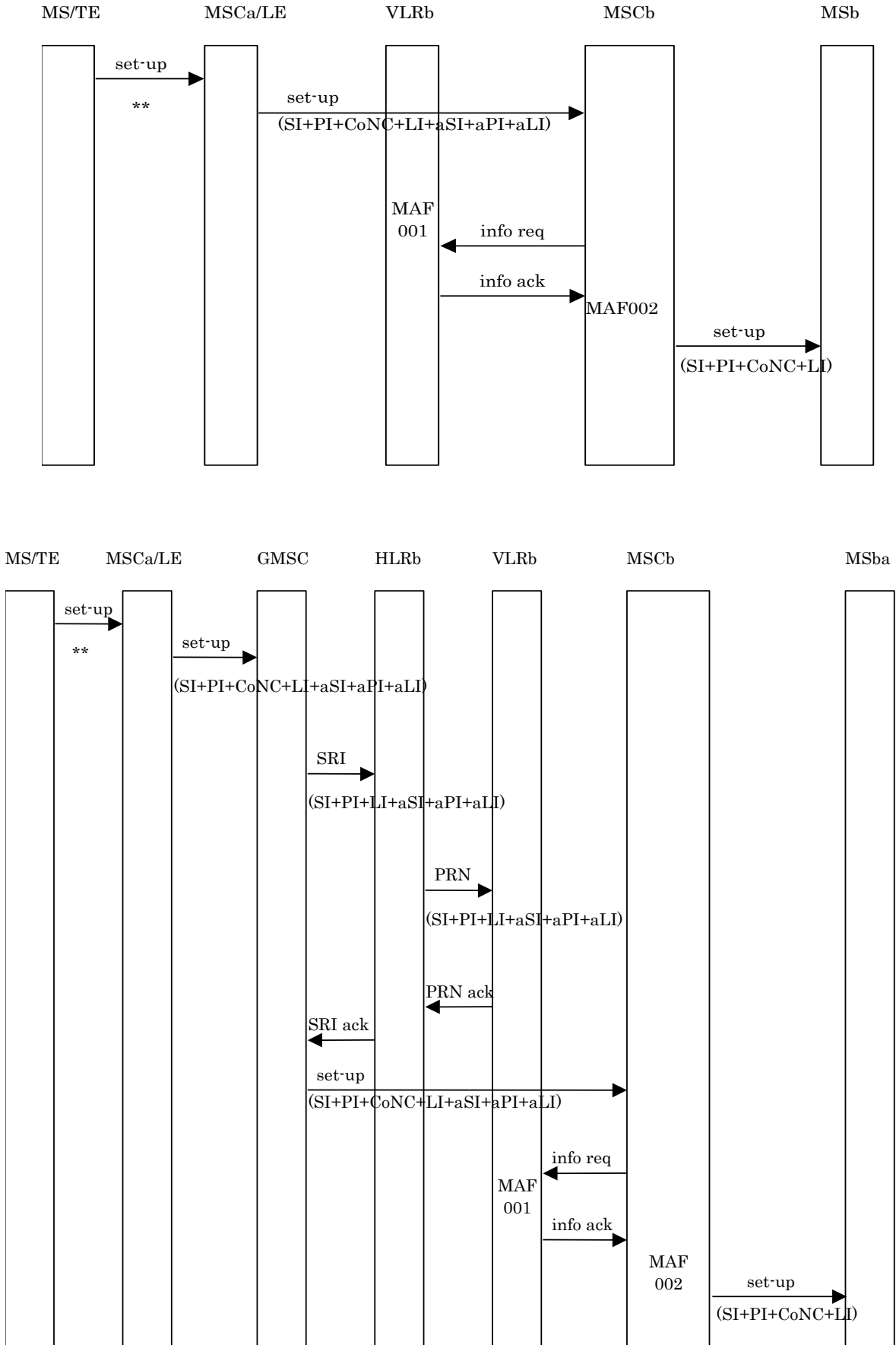

Figure 1.9: Information flow for calling line identification presentation: mobile station or fixed terminal to mobile station

NOTE:

** : A subaddress may be received from the originating MS or the TE
 info: information SI: screening indicator aSI: additional screening indicator
 req: request PI: presentation indicator CoNC: cause of no CLI
 aPI: additional presentation indicator
 ack: acknowledge LI: line identity aLI: additional line identity

NOTE: For mapping rules of CLI parameters refer to Annex A.

1.2.1 Optional capability to carry calling line identification

When GMSC is performing Send Routing Info query it may pass calling line identification to the HLRb. The calling line identification shall be in international format. If the HLRb receives calling line identification within Send Routing Info it may pass unmodified calling line identification within Provide Roaming Number to the VLRb. HLR shall not pass calling line identification in the HPLMN nor in the case where sending of the CLI information is explicitly denied to the destination network..

If MSCb receives calling line identification only from signalling it shall use that parameter for presentation purposes i.e. normal handling as described in the previous subclause applies.

If MSCb receives Cause of no CLI from signalling it shall be sent to the VLRb by Send Info for Incoming Call query.

If MSCb receives calling line identification and/or Cause of no CLI from VLRb and it supports the feature it shall use that parameter for presentation purposes. In this case calling line identification is stored in the VLRb and when the set-up message is processed the handling described in the previous subclause is done using the stored calling line identification.

1.2.2 Information elements used in the messages

Table 1.2.2.1: Information elements used in messages

Information Element	Logical Information element name	Information element Required	Information element description
Calling Party Number	SI	M	Calling Party Number contains screening indicator (SI), presentation indicator (PI) and line identity (LI) as mandatory information.
	PI	M	
	LI	M	
Generic Number	aSI	M	Generic Number contains additional screening indicator (aSI), additional presentation indicator (aPI) and additional line identity (aLI) as mandatory information.
	aPI	M	
	aLI	M	
Cause of no CLI	unavailable	M	Cause of no CLI contains detailed Cause of no CLI (unavailable, reject by user, interaction with other service, coin line/payphone) as mandatory information.
	reject by user	M	
	interaction with other service	M	
	coin line/payphone	M	

1.2.3 Parameters in Send Routeing Info and Provide Roaming Number for CLI

Table 1.2.3.1: Messages between GMSC and HLR

Message	Message sender	Information element name	Information element Required	Information element description
Send Routeing Info	GMSC	-	-	Refer to 3GPP TS 23.018.
		Calling Party Number	C	In addition: The information element is present if GMSC received calling party number from originating network; otherwise it shall be absent.
		Generic Number	C	The information element is present if GMSC received additional calling party number from originating network or from gsmSCF because of a CAMEL service; otherwise it shall be absent.

Table 1.2.3.2: Messages between HLR and VLR

Message	Message sender	Information element name	Information element Required	Information element description
Provide Roaming Number	HLR	-	-	Refer to 3GPP TS 23.018.
		Calling Party Number	C	In addition: The information element is present if HLR received calling party number from GMSC and MS B is outside of home country; otherwise it shall be absent.
		Generic Number	C	The information element is present if HLR received additional calling party number from GMSC and MS B is outside of home country; otherwise it shall be absent.

1.2.4 Messages between MSC and VLR in destination network

Table 1.2.4.1: Messages between MSC and VLR

Message	Message sender	Information element name	Information element Required	Information element description		
Complete Call	VLR	-	-	Refer to 3GPP TS 23.018.		
		Calling Party Number	C	In addition: The information element is present if it is stored in VLR; otherwise it shall be absent.		
		Generic Number	C	The information element is present if it is stored in VLR; otherwise it shall be absent.		
Cause of no CLI	C	The information element is present if it is stored in VLR; otherwise it shall be absent.				
		Process Call Waiting	VLR	-	-	Refer to 3GPP TS 23.018.
		Calling Party Number		C	In addition: The information element is present if it is stored in VLR; otherwise it shall be absent.	
Generic Number	C	The information element is present if it is stored in VLR; otherwise it shall be absent.				
Cause of no CLI	C	The information element is present if it is stored in VLR; otherwise it shall be absent.				
		Send Info for Incoming Call	MSC	-	-	Refer to 3GPP TS 23.018.
Cause of no CLI	C	In addition: The information element is present if MSC received Cause of no CLI; otherwise it shall be absent.				

1.3 Information stored in the HLR

CLIP may have the following logical states (refer to 3GPP TS 23.011 for an explanation of the notation):

Provisioning State	Registration State	Activation State	HLR Induction State
(Not Provisioned,	Not Applicable,	Not Active,	Not Induced)
(Provisioned,	Not Applicable,	Active and Operative,	Not Induced)

The HLR shall store the logical state of CLIP (which shall be one of the valid states listed above) on a per subscriber basis.

The HLR shall also store the subscription option "override category" on a per subscriber basis.

This parameter takes one of the following values:

1. yes;
2. no.

1.4 State transition model

The following figure shows the successful cases of transition between the applicable logical states of CLIP. The state changes are caused by actions of the service provider.

Note that error cases are not shown in the diagram as they normally do not cause a state change. Additionally, some successful requests may not cause a state change. Hence they are not shown in the diagram.

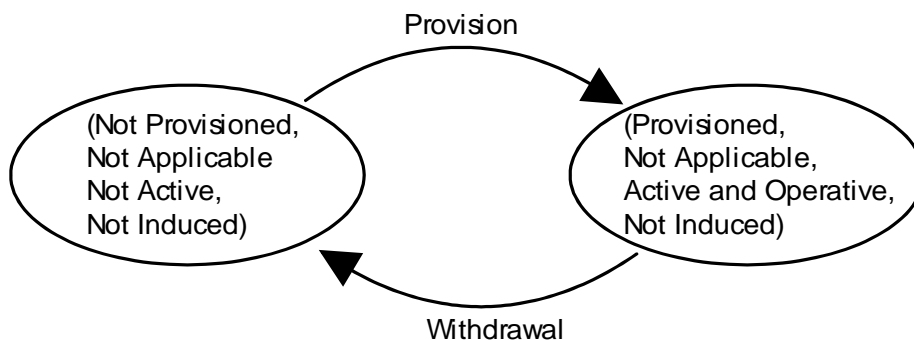

Figure 1.9: State transition model for CLIP

1.5 Transfer of information from HLR to VLR

If the provisioning state for CLIP is "Provisioned" then, when the subscriber registers on a VLR, the HLR shall send that VLR information about the logical state of CLIP. The HLR shall send the override category if the VLR is in the HPLMN country. The HLR may send the override category if the VLR is outside the HPLMN country.

If the logical state of CLIP or the override category is changed while a subscriber is registered on a VLR then the HLR shall inform the VLR of the new logical state of CLIP. If the override category is changed and the provisioning state of CLIP is "Provisioned" then the HLR shall inform the VLR about the new override category when the VLR is in the HPLMN country. The HLR may inform the VLR about the new override category when the VLR is outside the HPLMN country.

1.6 Information stored in the VLR

For CLIP, the VLR shall store the service state information and override category received from the HLR.

If not received from the HLR (case of roaming outside the HPLMN country), the override category shall be set to the default value "no".

1.7 Handover

Handover will have no impact on the control procedures and the operation of the service.

1.8 Interactions with other supplementary services

See 3GPP TS 22.081 [4] subclause 1.6.

2 Calling line identification restriction (CLIR)

2.1 Handling of calling line identification restriction

2.1.1 General

If the originating party has calling line identification restriction provisioned and it is impossible to indicate to the terminating network (due to interworking) that the number should not be presented to the terminating party, the calling line identity shall not be delivered to the terminating network.

2.1.2 Permanent mode

If the subscriber has calling line identification restriction provisioned in permanent mode, the originating party's CLI shall not be presented to the terminating party (i.e. the terminating MS or TE), unless the terminating party has calling line identification presentation provisioned with the subscription option "override category" set (see clause 1).

2.1.3 Controlling presentation of the CLI when CLIR is provisioned in temporary mode

A subscriber can have calling line identification restriction provisioned in temporary mode with one of two default values: presentation restricted or presentation allowed.

If the default value is set to presentation restricted, the default handling is not to present the originating party's CLI to the terminating party (i.e. the terminating MS or TE).

However, it is possible for the originating subscriber to present his CLI to the terminating party. The originating subscriber must indicate during call set-up that the CLI must be presented to the terminating party. This procedure is illustrated in figure 2.1.

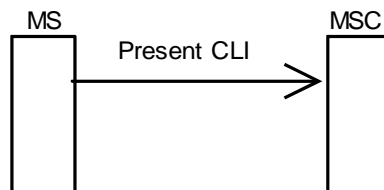

Figure 2.1: MS indicating presentation of CLI when CLIR is provisioned in temporary mode with default value "presentation restricted"

If the default value is set to presentation allowed, the default handling is to present the originating party's CLI to the terminating party (i.e. the terminating MS or TE).

However, it is possible for the originating subscriber to restrict presentation of his CLI to the terminating party. The originating subscriber must indicate during call set-up that CLI presentation must be restricted. This procedure is illustrated in figure 2.2.

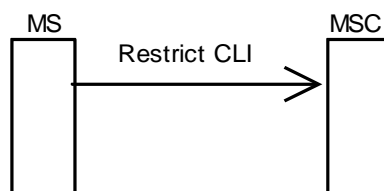

Figure 2.2: MS invoking CLIR, when CLIR is provisioned in temporary mode with default value "presentation allowed"

2.1.4 Interrogation

Data request

The mobile subscriber can request the data of the supplementary service.

In response the following information shall be given:

- whether the service is provided or not;
- if provided which mode is subscribed;
- if subscribed to the temporary mode: which default value.

This procedure is illustrated in figure 2.3.

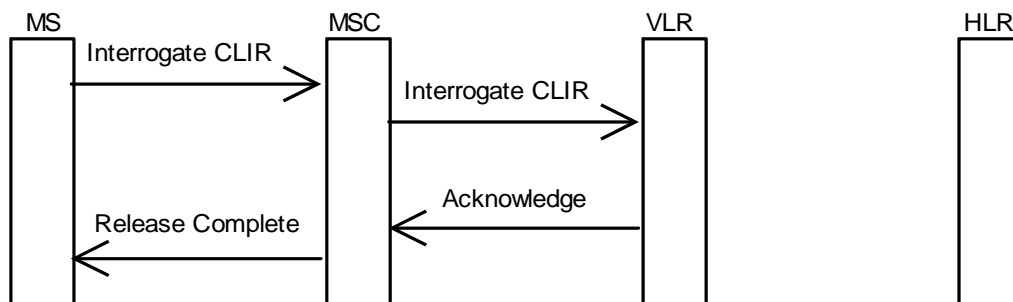

Figure 2.3: Interrogation of calling line identification restriction

2.2 Functions and information flows

The following Mobile Additional Functions have been identified for the PLMN:

MAF003

Determination of the calling line identification restriction subscription

The ability of a PLMN component to determine whether the supplementary service is provisioned for the mobile subscriber. See figure 2.4.

Location: VLR.

MAF004

Determination of the calling party number for offering to the called party

The ability of a PLMN component to determine and to forward the calling line identity and related indications to the called party. See figure 2.5.

Location: originating MSC.

The information flows are shown in figures 2.6 to 2.9.

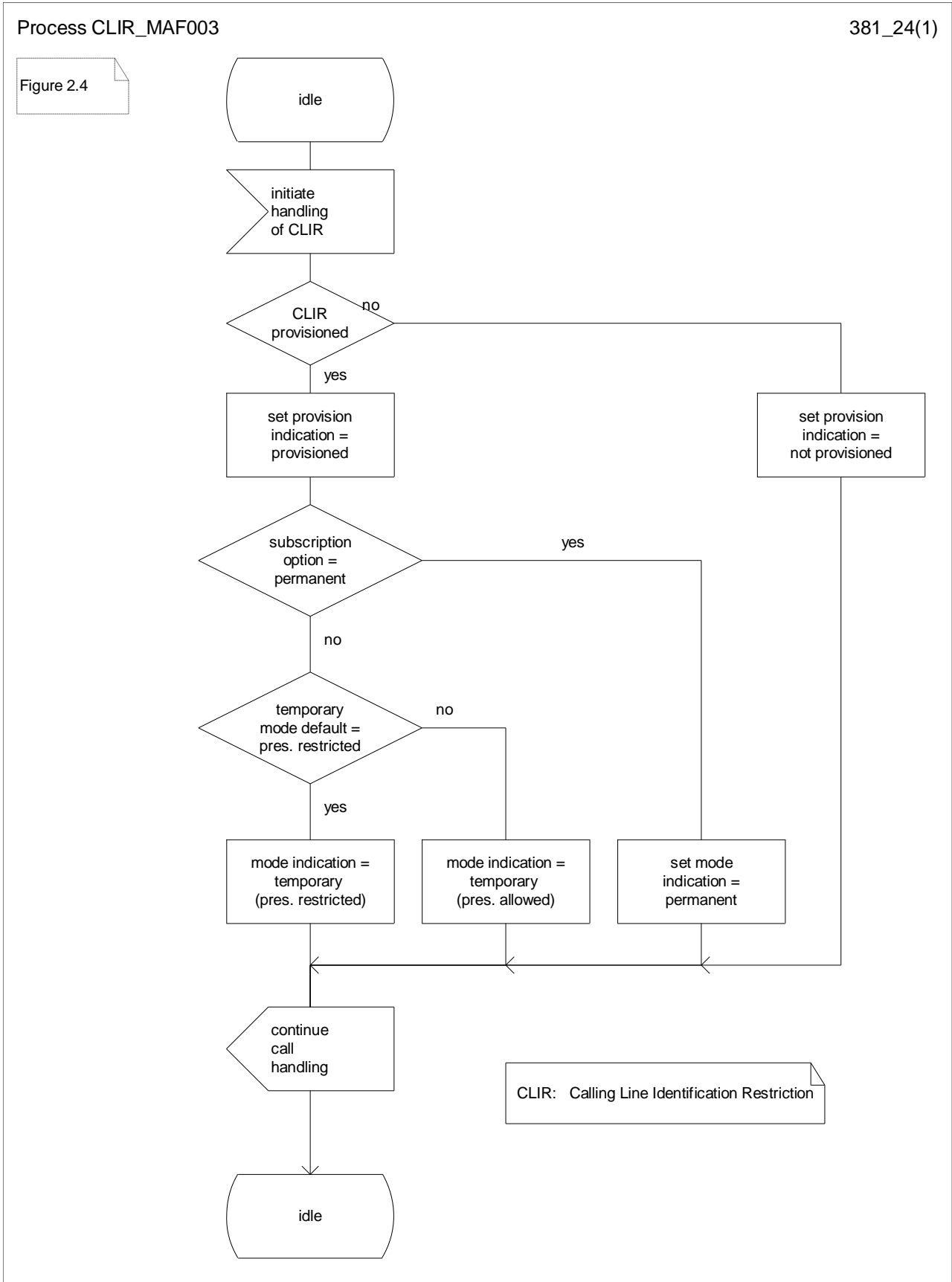

Figure 2.4: MAF003 Determination of calling line identification restriction subscription (VLR)

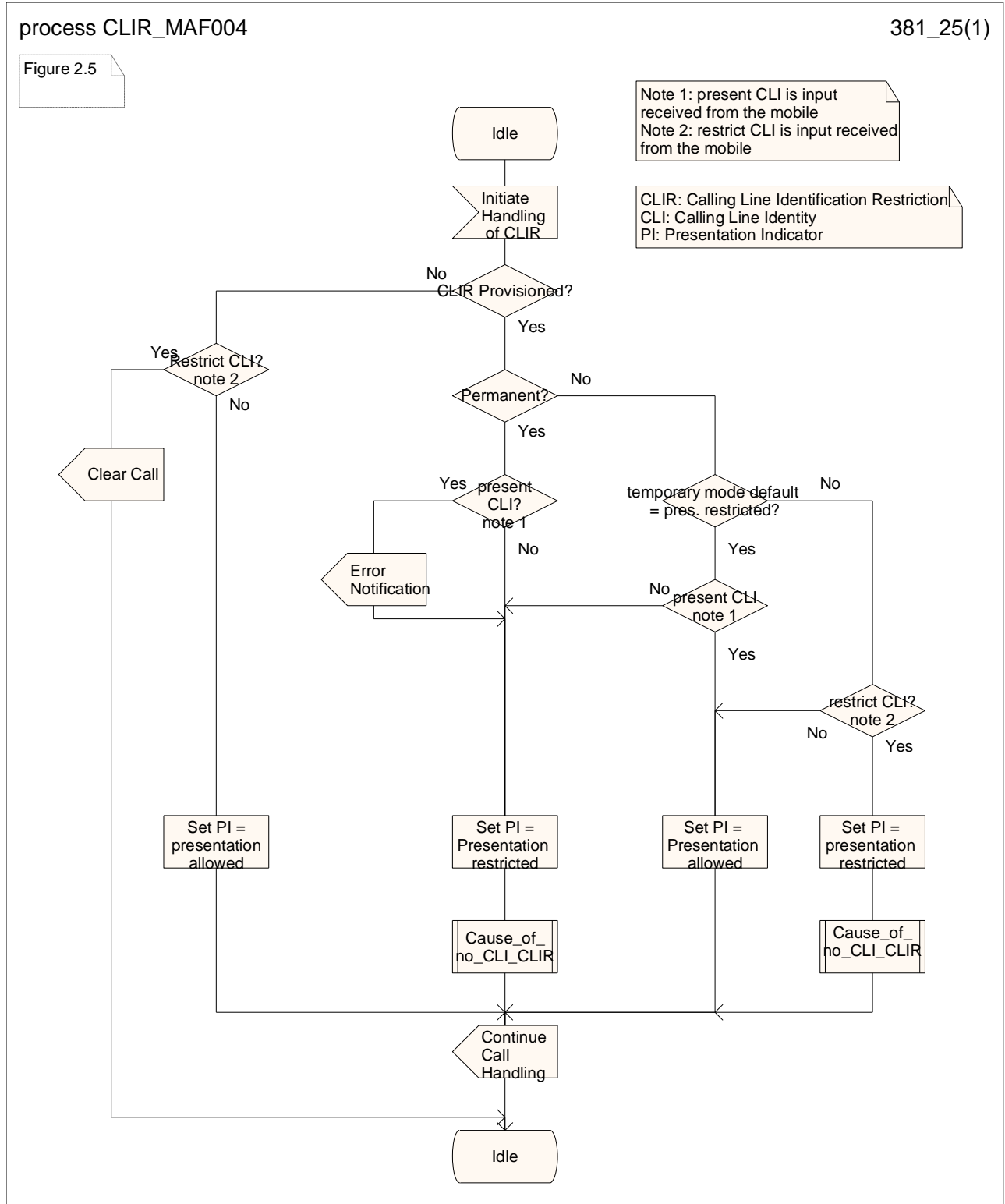

Figure 2.5: MAF004 Determination of the presentation indicator (originating MSC)

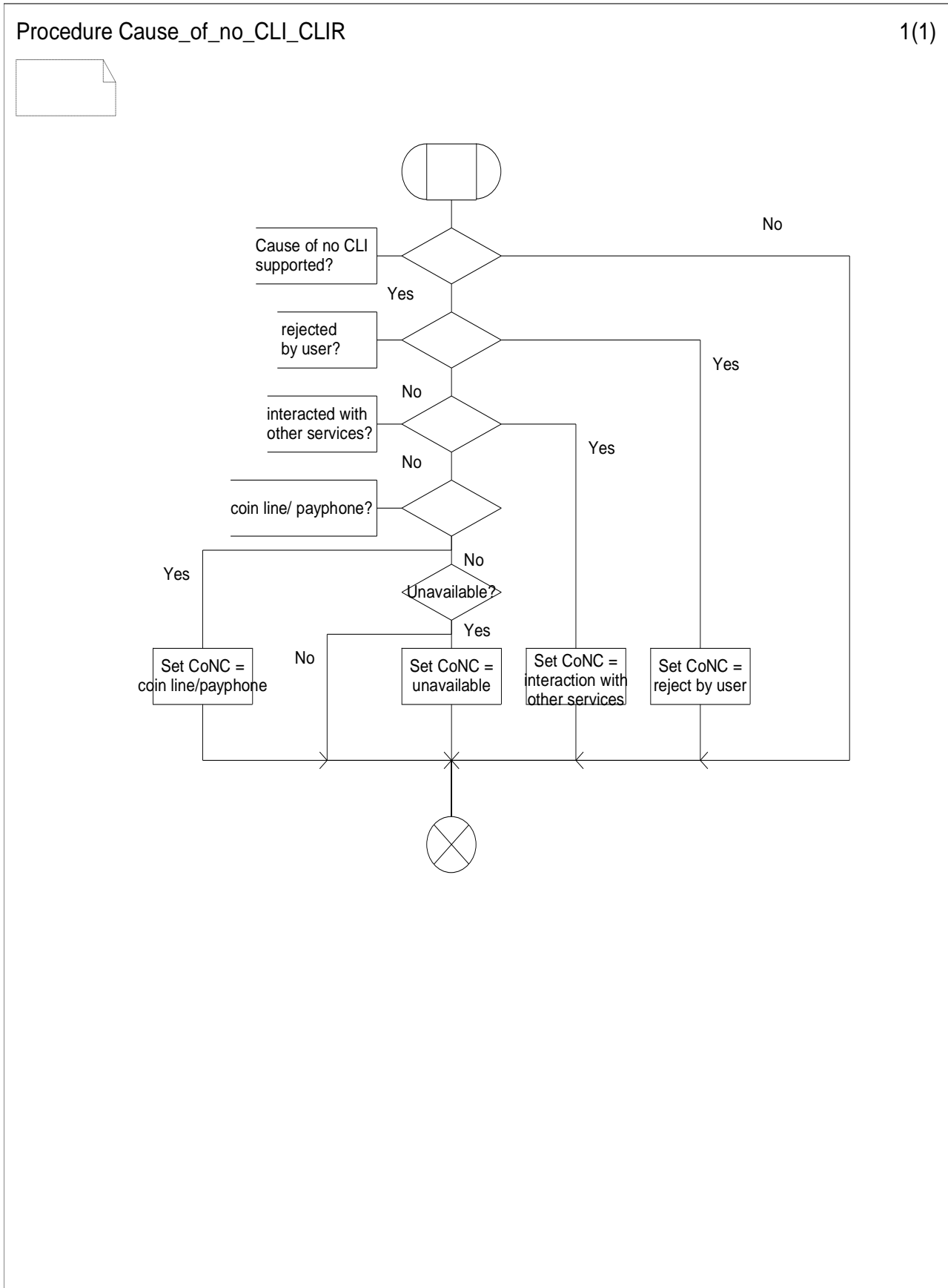

Figure 2.6: Procedure Cause_of_no_CLI_CLIR

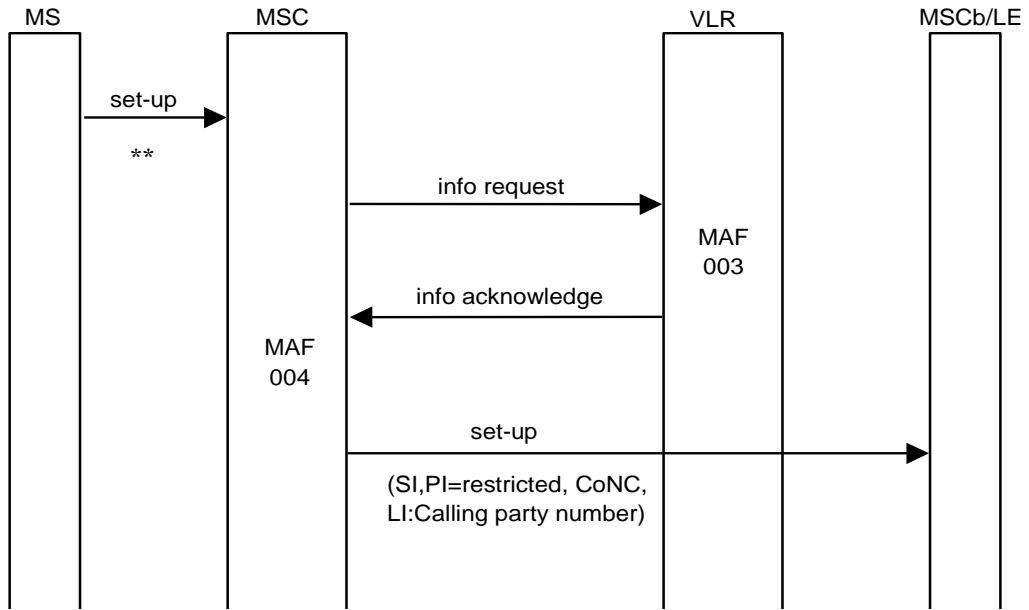

Figure 2.7: Information flow for calling line identification restriction in permanent or temporary mode with the default value "presentation restricted"

NOTE: **: A subaddress may be received from the MS
 SI: screening indicator
 PI: presentation indicator
 LI: line identity

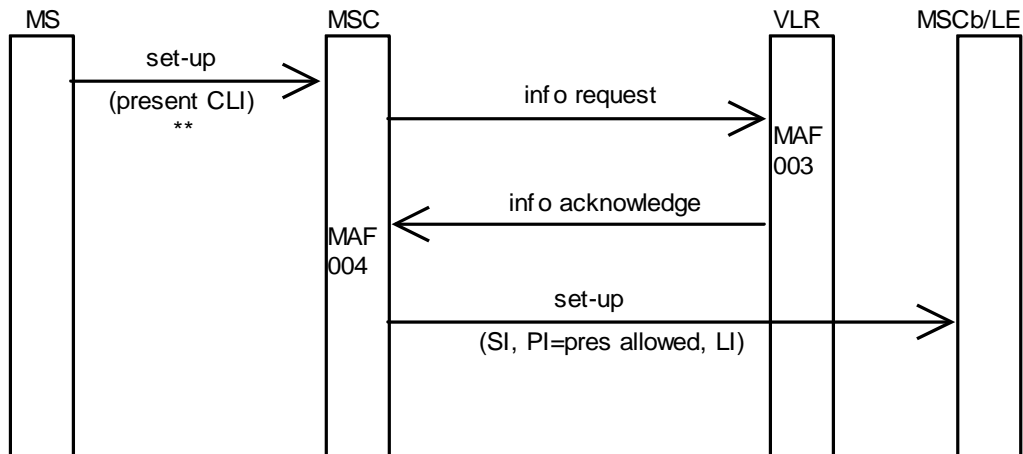
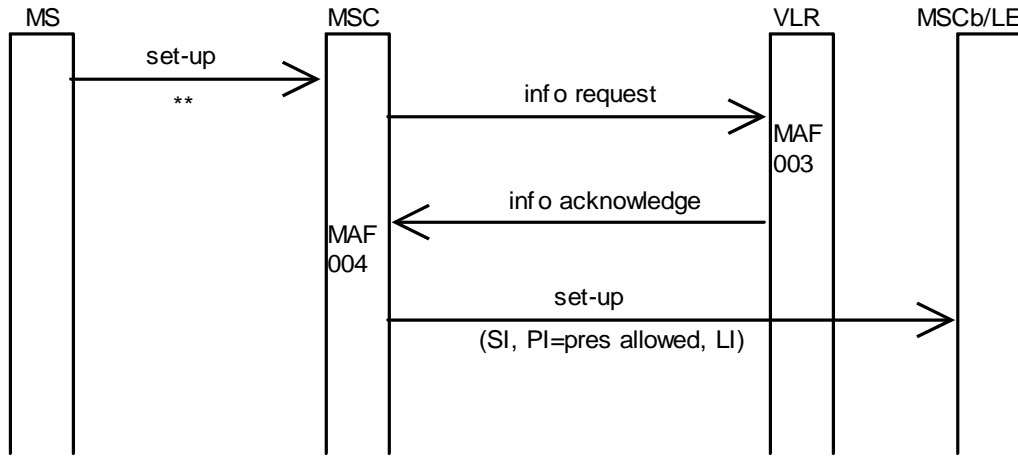

Figure 2.8: Information flow for allowing presentation of the CLI when CLIR is provisioned in temporary mode with default value "presentation restricted"

NOTE: **: A subaddress may be received from the MS
 SI: screening indicator
 PI: presentation indicator
 LI: line identity
 CLI: calling line identity



NOTE: **: A subaddress may be received from the MS
 SI: screening indicator
 PI: presentation indicator
 LI: line identity

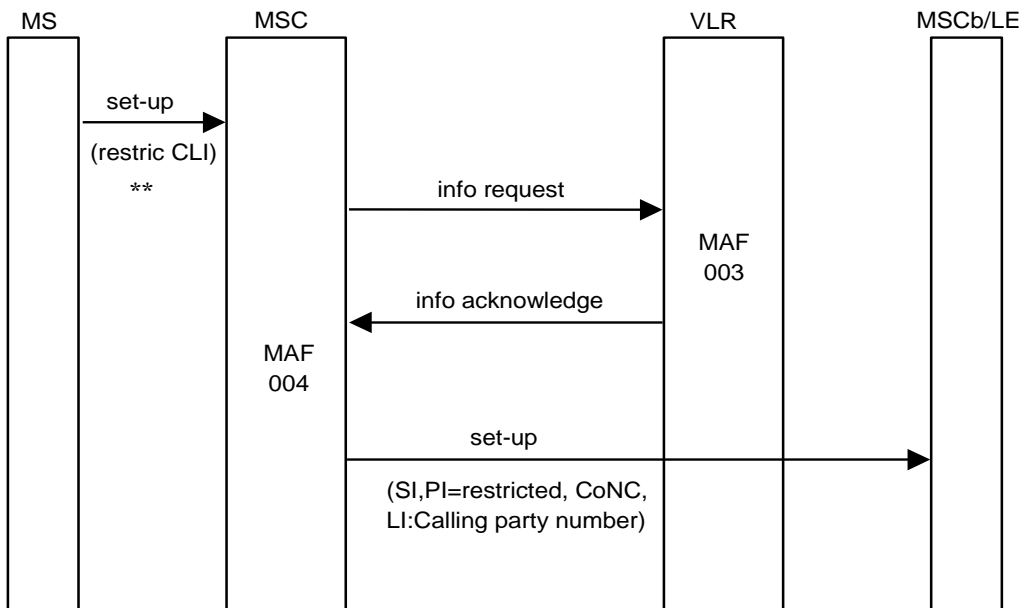

Figure 2.9: Information flow for calling line identification restriction in temporary mode with default value "presentation allowed"

NOTE: **: A subaddress may be received from the MS
 SI: screening indicator
 PI: presentation indicator
 LI: line identity
 CLI: calling line identity

2.3 Information stored in the HLR

CLIR may have the following logical states (refer to 3GPP TS 23.011 for an explanation of the notation):

Provisioning State	Registration State	Activation State	HLR Induction State
(Not Provisioned,	Not Applicable,	Not Active,	Not Induced)
(Provisioned,	Not Applicable,	Active and Operative,	Not Induced)

The HLR shall store the logical state of CLIR (which shall be one of the valid states listed above) on a per subscriber basis.

The HLR shall also store the subscription option "presentation mode" on a per subscriber basis.

This parameter takes one of the following values:

- permanent;
- temporary (presentation restricted);
- temporary (presentation allowed).

2.4 State transition model

The following figure shows the successful cases of transition between the applicable logical states of CLIR. The state changes are caused by actions of the service provider.

Note that error cases are not shown in the diagram as they normally do not cause a state change. Additionally, some successful requests may not cause a state change. Hence they are not shown in the diagram.

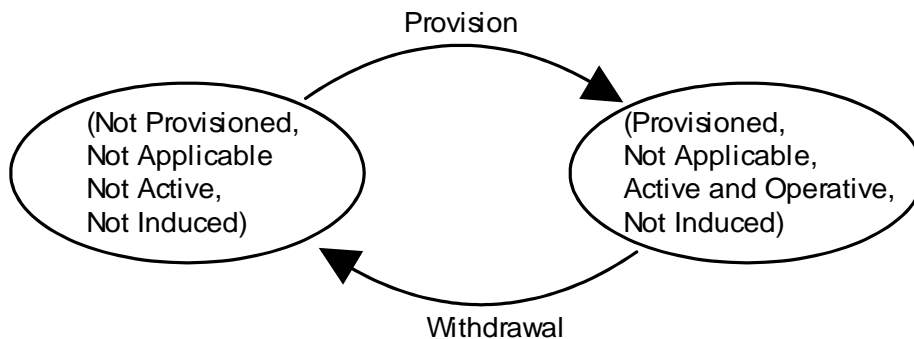

Figure 2.10: State transition model for CLIR

2.5 Transfer of information from HLR to VLR

When the subscriber registers on a VLR, the HLR shall send that VLR information about the logical state of CLIR and the presentation mode.

If the logical state of CLIR or the presentation mode is changed while a subscriber is registered on a VLR then the HLR shall inform the VLR of the new logical state of CLIR and (if the provisioning state is "Provisioned") the new presentation mode.

2.6 Information stored in the VLR

For CLIR, the VLR shall store the service state information and presentation mode received from the HLR.

2.7 Handover

Handover will have no impact on the control procedures and the operation of the service.

2.8 Interworking

The VPLMN needs to distinguish three cases in order to meet data privacy requirements in an environment where support of CLIP and CLIR is optional:

- the HPLMN supports CLIR, and CLIR is provisioned for the subscriber;
- the HPLMN supports CLIR, but CLIR is not provisioned for the subscriber;
- the HPLMN does not support CLIR.

In case a) the VPLMN must apply the CLIR subscription as indicated by the data sent by the HPLMN.

In case b) the VPLMN must not apply CLIR.

In case c) the VPLMN must apply an implicit CLIR subscription.

To allow the VPLMN to make this distinction, the HLR and VLR behave as follows:

- If the HLR supports CLIR, but CLIR is not provisioned for the subscriber, the HLR shall inform the VLR that CLIR is not provisioned.
- If the VLR supports CLIR, but the HLR does not support CLIR, the VLR shall behave in the same way as if CLIR (temporary (presentation restricted)) was provisioned for the subscriber, i.e. the calling line identity shall not be displayed to the called subscriber unless the called subscriber has CLIR override capability. When interrogating the service status the subscriber shall be informed that CLIR (temporary (presentation restricted)) is provided to him and is active.

3 Connected line identification presentation (COLP)

3.1 Handling of connected line identification presentation

3.1.1 Interrogation

Status check

The mobile subscriber can request the status of the supplementary service and be informed if the service is provided to him/her. This procedure is illustrated in figure 3.1.

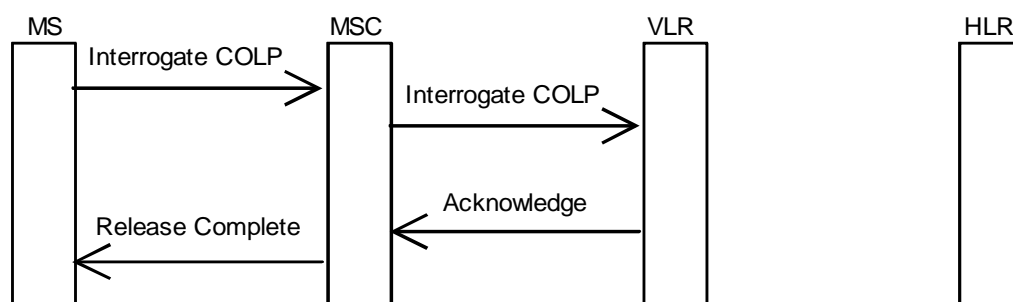

Figure 3.1: Interrogation of connected line identification presentation

3.1.2 Interactions with call forwarding supplementary services

If the forwarding user selects the option that the calling user is not notified of the call forwarding, then the calling user shall receive no forwarding notification, and the calling user shall not receive the connected user's identity when the call is answered, unless the calling user has override capability.

3.2 Functions and information flows

The following Mobile Additional Functions have been identified for the PLMN:

MAF005

Determination of the connected line identification presentation subscription

The ability of a PLMN component to determine whether the supplementary service is provisioned for the mobile subscriber. See figure 3.2.

Location: VLR.

MAF006

Determination of the connected party number for offering to the calling party

The ability of a PLMN component to determine and to forward the connected line identity and related indications to the calling party. See figure 3.3.

Location: originating MSC.

MAF039

Interaction of connected line identification presentation with the call forwarding supplementary services

The ability of a PLMN component to determine the presentation indicator of the connected party number after invocation of a call forwarding service. See figure 3.4.

Location: forwarding MSC.

The information flow is shown in figure 3.5.

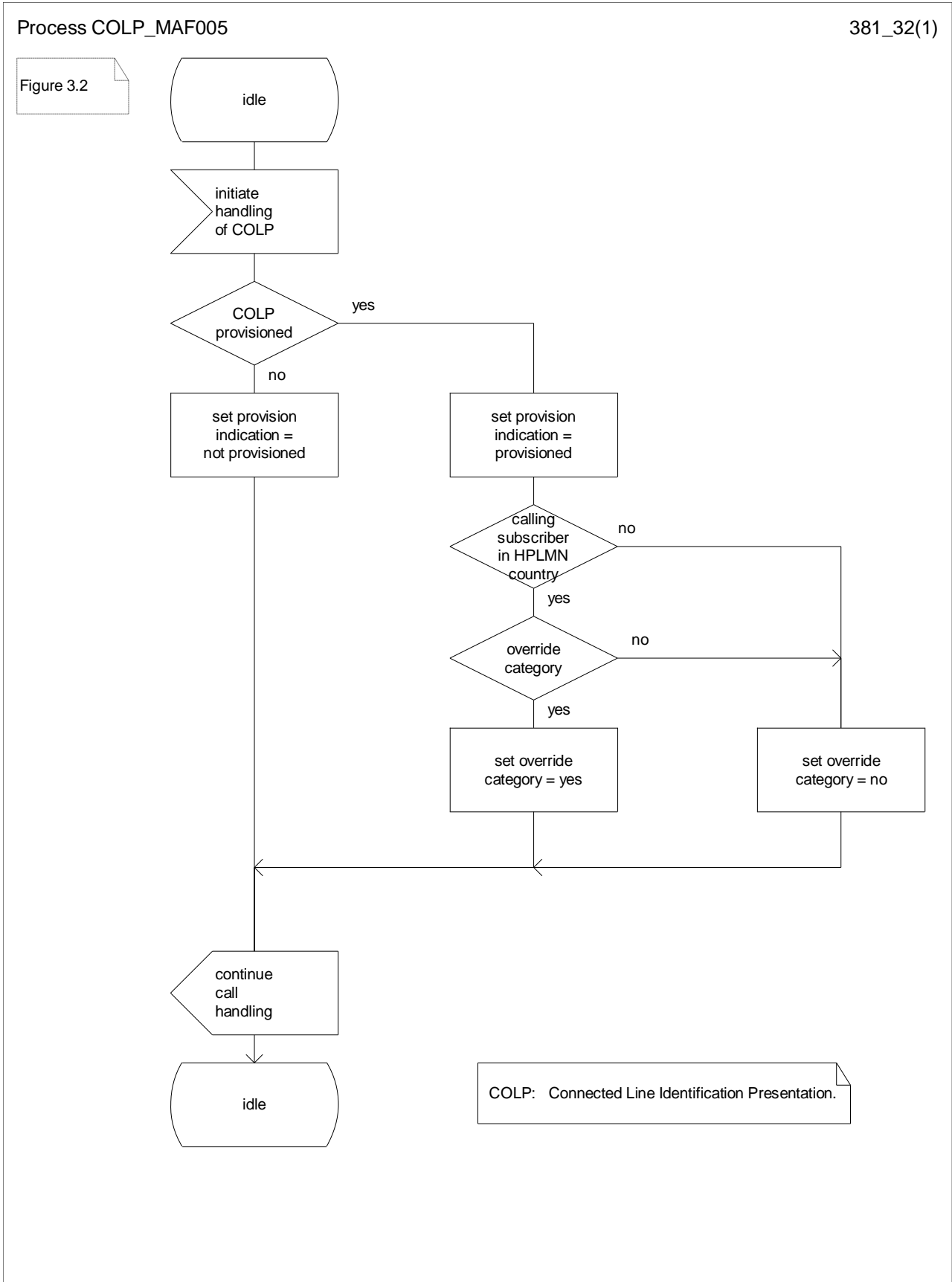

Figure 3.2: MAF005 Determination of connected line identification presentation subscription (VLR)

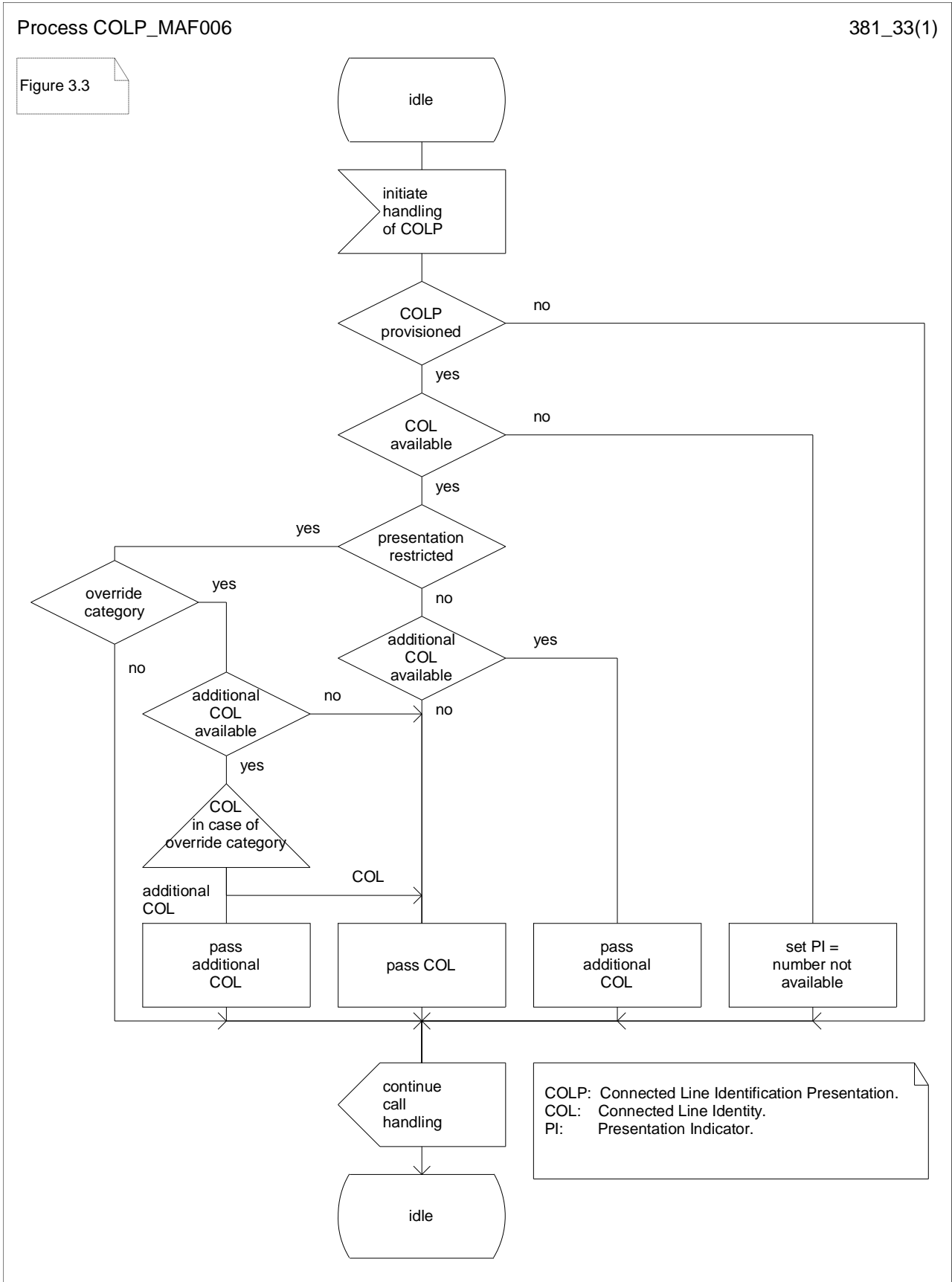

Figure 3.3: MAF006 Determination of the information for offering to the connected party (originating MSC)

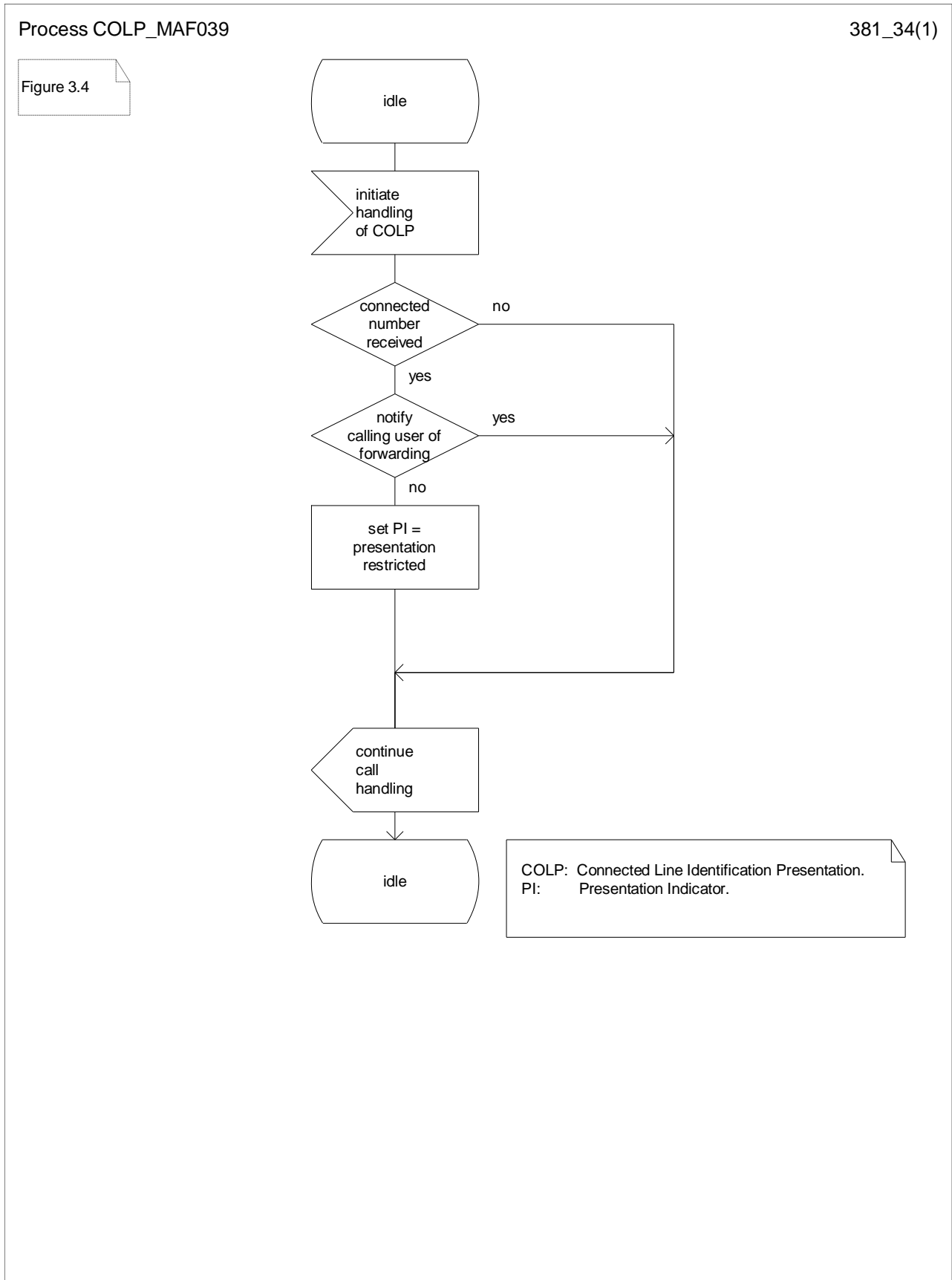

Figure 3.4: MAF039 Interaction between COLP and call forwarding services (forwarding MSC)

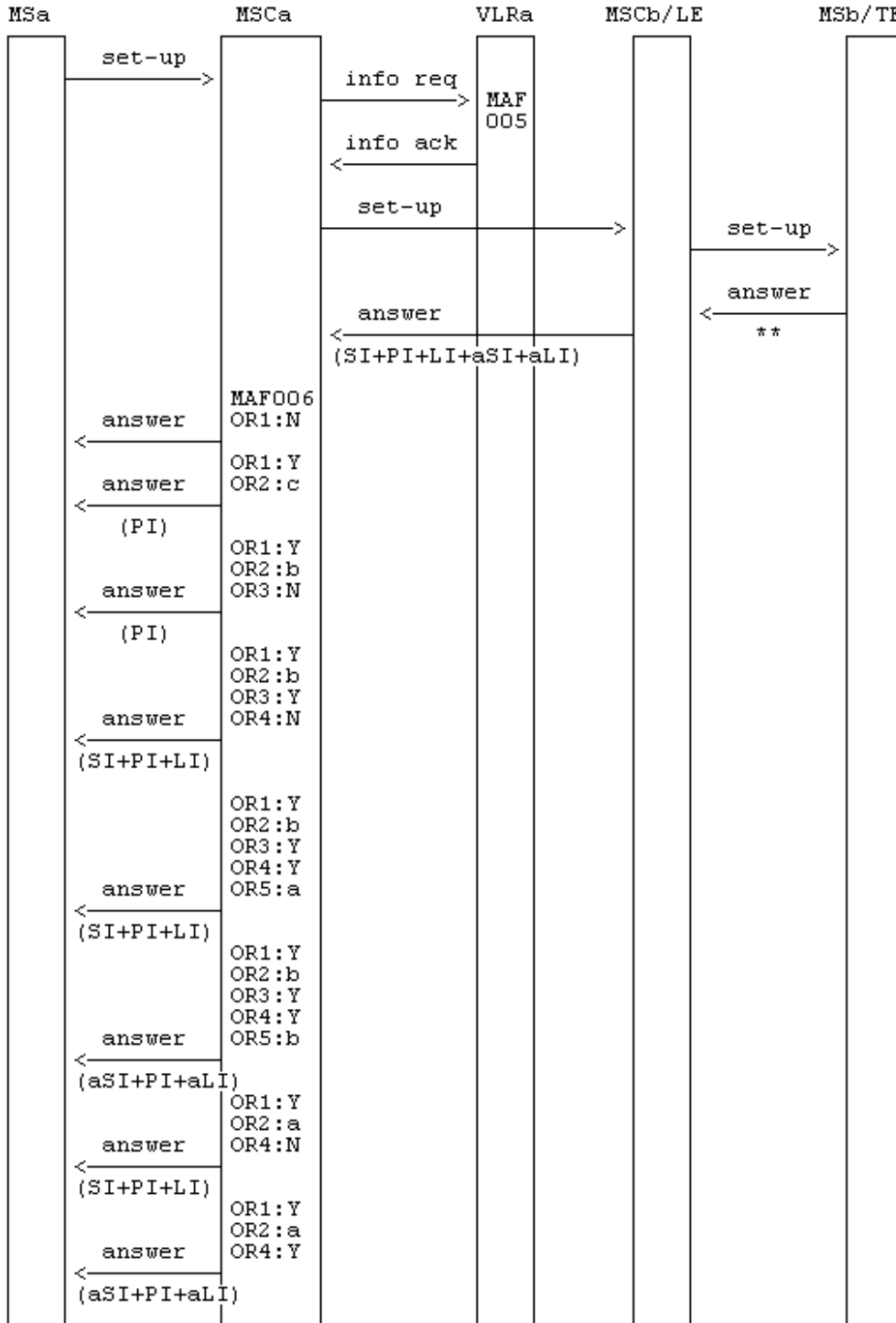

Figure 3.5: Information flow for connected line identification presentation: mobile station to mobile station or fixed terminal

- NOTE:
- OR1: COLP provisioned Y: yes N: no
 - OR2: Presentation Indicator Value a: allowed b: restricted c: not available
 - OR3: Override category
 - OR4: additional line identity available Y: yes N: no
 - OR5: COL in case of override category a: LI b: aLI
 - ** : A connected subaddress may be received from the MS
 - info: information SI: screening indicator aSI: additional screening indicator
 - req: request PI: presentation indicator
 - ack: acknowledge LI: line identity aLI: additional line identity

3.3 Information stored in the HLR

COLP may have the following logical states (refer to 3GPP TS 23.011 for an explanation of the notation):

Provisioning State	Registration State	Activation State	HLR Induction State
(Not Provisioned,	Not Applicable,	Not Active,	Not Induced)
(Provisioned,	Not Applicable,	Active and Operative,	Not Induced)

The HLR shall store the logical state of COLP (which shall be one of the valid states listed above) on a per subscriber basis.

The HLR shall also store the subscription option "override category" on a per subscriber basis.

This parameter takes one of the following values:

- yes;
- no.

3.4 State transition model

The following figure shows the successful cases of transition between the applicable logical states of COLP. The state changes are caused by actions of the service provider.

Note that error cases are not shown in the diagram as they normally do not cause a state change. Additionally, some successful requests may not cause a state change. Hence they are not shown in the diagram.

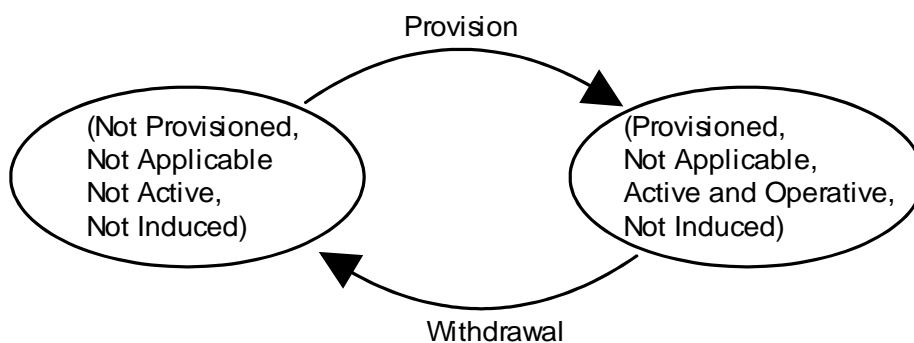

Figure 3.6: State transition model for COLP

3.5 Transfer of information from HLR to VLR

If the provisioning state for COLP is "Provisioned" then, when the subscriber registers on a VLR, the HLR shall send that VLR information about the logical state of COLP. The HLR shall send the override category if the VLR is in the HPLMN country. The HLR may send the override category if the VLR is outside the HPLMN country.

If the logical state of COLP or the override category is changed while a subscriber is registered on a VLR then the HLR shall inform the VLR of the new logical state of COLP. If the override category is changed and the provisioning state of COLP is "Provisioned" then the HLR shall inform the VLR about the new override category when the VLR is in the HPLMN country. The HLR may inform the VLR about the new override category when the VLR is outside of the HPLMN country.

3.6 Information stored in the VLR

For COLP, the VLR shall store the service state information and override category received from the HLR.

If not received from the HLR (case of roaming outside the HPLMN country), the override category shall be set to the default value “no”.

3.7 Handover

Handover will have no impact on the control procedures and the operation of the service.

4 Connected line identification restriction (COLR)

4.1 Handling of connected line identification restriction

4.1.1 General

If the terminating party has connected line identification restriction provisioned and it is impossible to indicate to the originating network (due to interworking) that the number should not be presented to the originating party, the connected line identity shall not be delivered to the originating network.

4.1.2 Interrogation

Status check

The mobile subscriber can request the status of the supplementary service and be informed if the service is provided to him/her. This procedure is illustrated in figure 4.1.

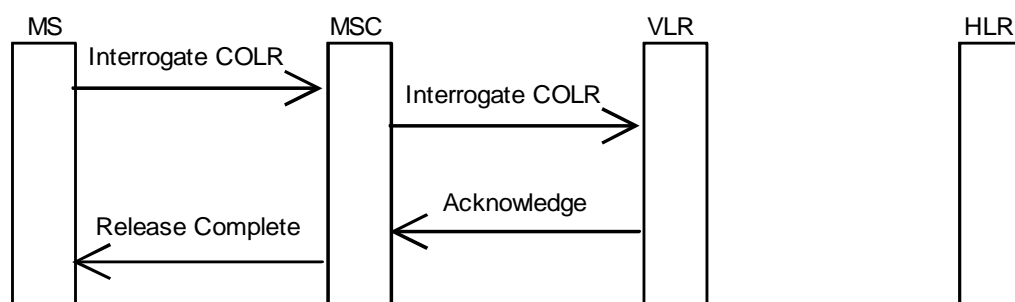

Figure 4.1: Interrogation of connected line identification restriction

4.2 Functions and information flows

The following Mobile Additional Functions have been identified for the PLMN:

MAF040

Determination of the connected line identification restriction subscription

The ability of a PLMN component to determine whether the supplementary service is provisioned for the mobile subscriber. See figure 4.2.

Location: VLR.

MAF041

Determination of the connected party number for offering to the calling party

The ability of a PLMN component to determine and to forward the connected line identity and related indications to the calling party. See figure 4.3.

Location: terminating MSC.

The information flow is shown in figures 4.4.

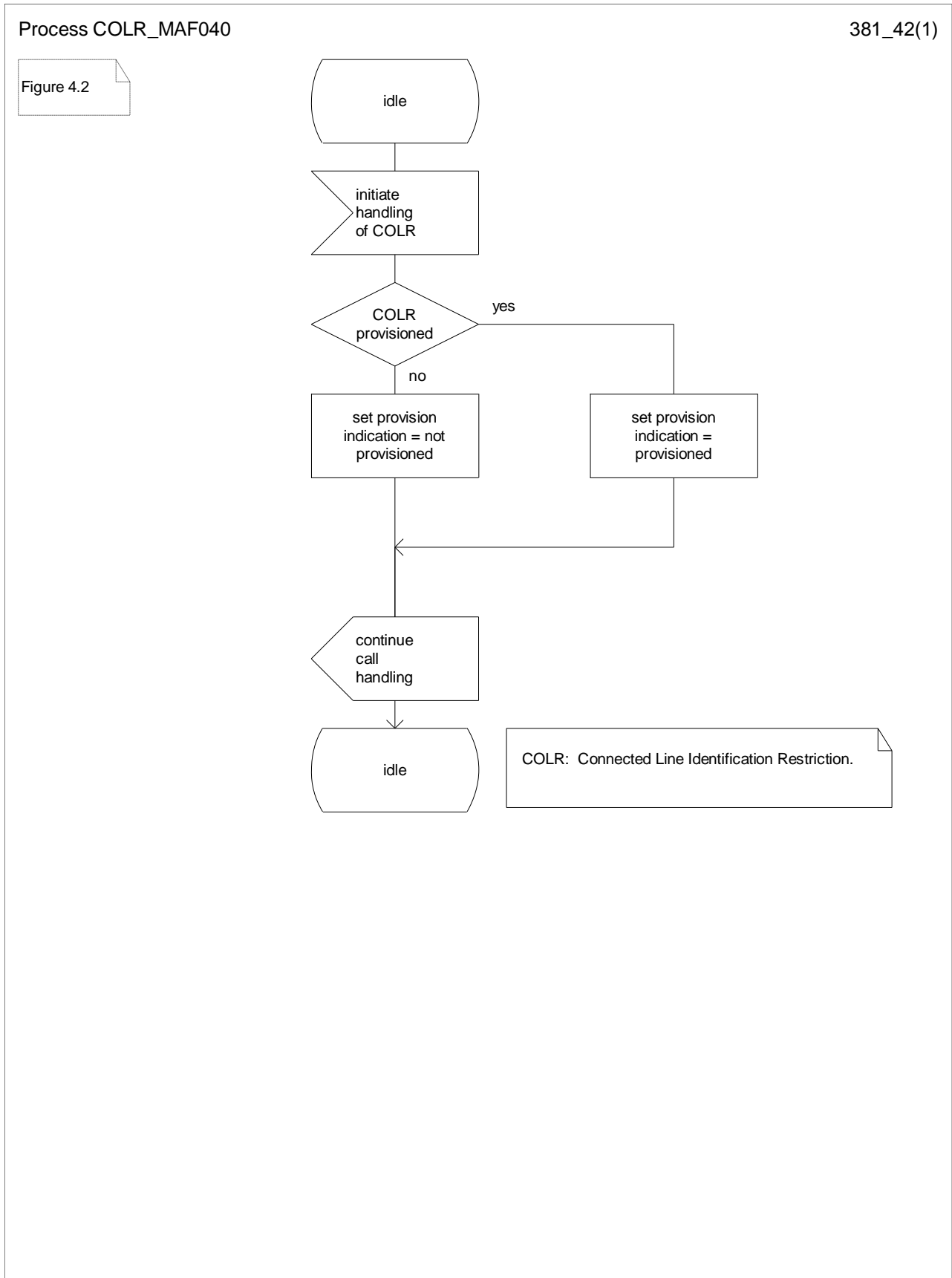

Figure 4.2: MAF040 Determination of connected line identification restriction subscription (VLR)

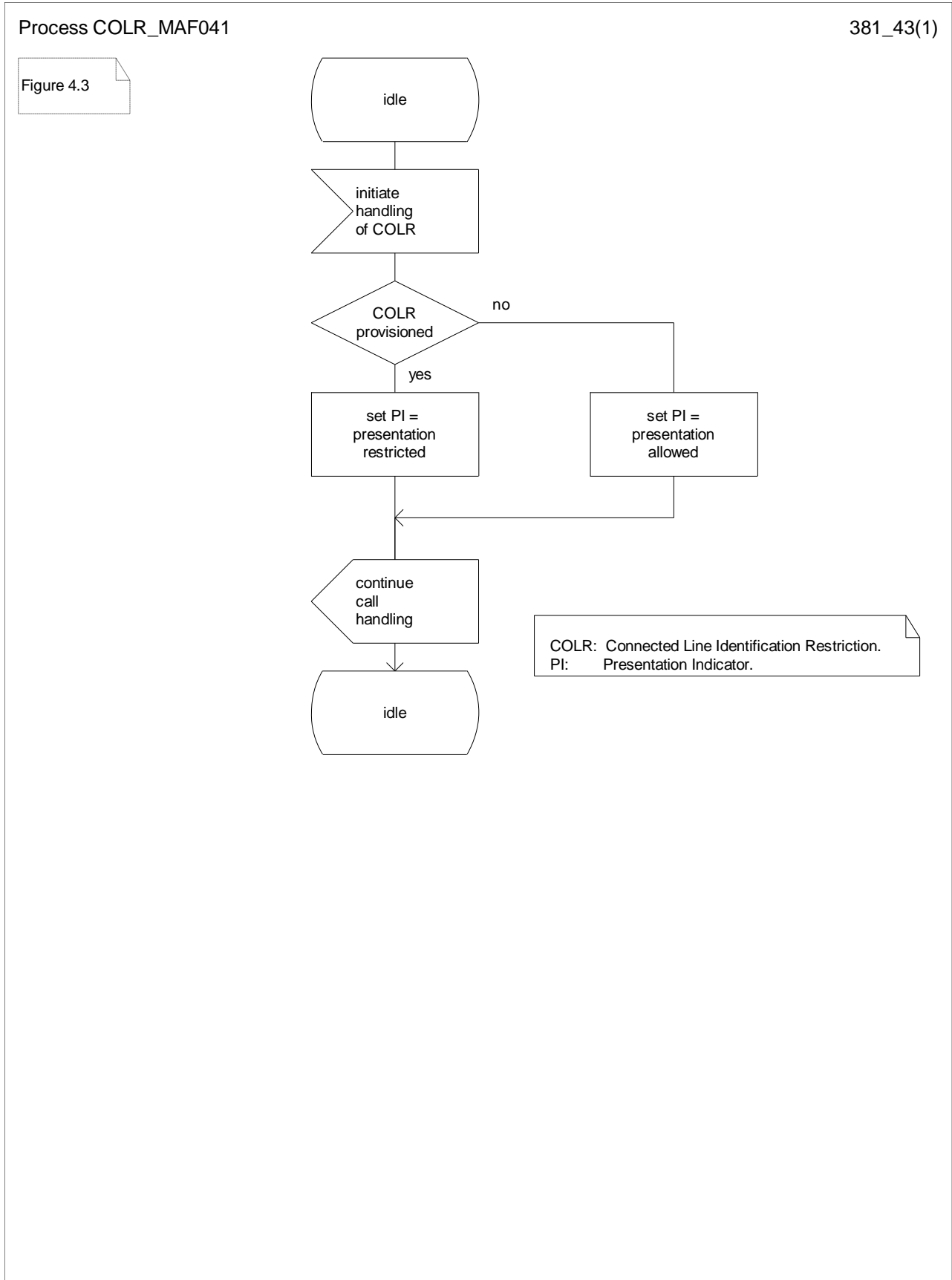

Figure 4.3: MAF041 Determination of the presentation indicator

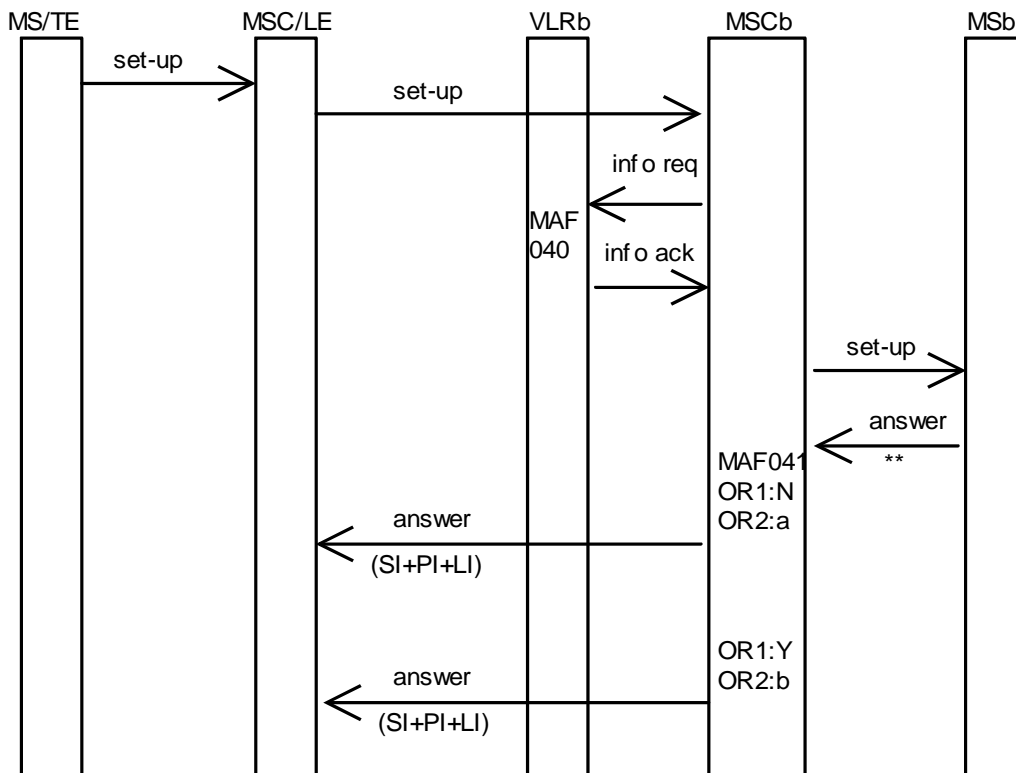

Figure 4.4: Information flow for connected line identification restriction: mobile station or fixed terminal to mobile station

NOTE: OR1: COLR provisioned Y: yes N: no
 OR2: Presentation Indicator Value a: allowed
 b: restricted
 OR3: Override category
 **: A subaddress may be received from the MS
 info: information SI: screening indicator
 req: request PI: presentation indicator
 ack: acknowledge LI: line identity

4.3 Information stored in the HLR

COLR may have the following logical states (refer to 3GPP TS 23.011 for an explanation of the notation):

Provisioning State	Registration State	Activation State	HLR Induction State
(Not Provisioned,	Not Applicable,	Not Active,	Not Induced)
(Provisioned,	Not Applicable,	Active and Operative,	Not Induced)

The HLR shall store the logical state of COLR (which shall be one of the valid states listed above) on a per subscriber basis.

4.4 State transition model

The following figure shows the successful cases of transition between the applicable logical states of COLR. The state changes are caused by actions of the service provider.

Note that error cases are not shown in the diagram as they normally do not cause a state change. Additionally, some successful requests may not cause a state change. Hence they are not shown in the diagram.

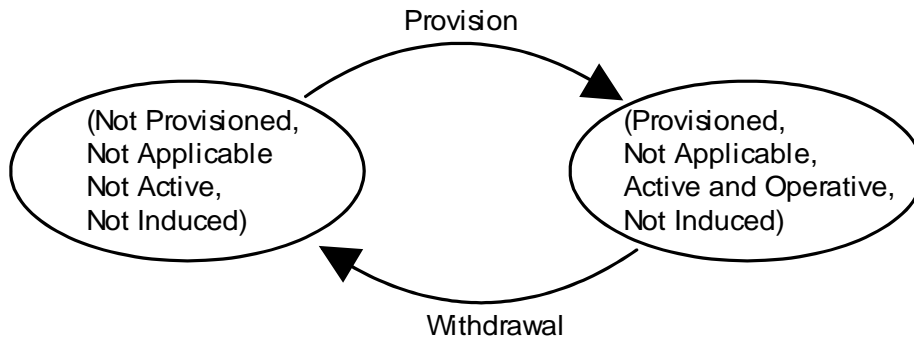

Figure 4.5: State transition model for COLR

4.5 Transfer of information from HLR to VLR

When the subscriber registers on a VLR, the HLR shall send that VLR information about the logical state of COLR.

If the logical state of COLR is changed while a subscriber is registered on a VLR then the HLR shall inform the VLR of the new logical state of COLR.

4.6 Information stored in the VLR

For COLR, the VLR shall store the service state information received from the HLR.

4.7 Handover

Handover will have no impact on the control procedures and the operation of the service.

4.8 Interworking

The VPLMN needs to distinguish three cases in order to meet data privacy requirements in an environment where support of COLP and COLR is optional:

- a) the HPLMN supports COLR, and COLR is provisioned for the subscriber;
- b) the HPLMN supports COLR, but COLR is not provisioned for the subscriber;
- c) the HPLMN does not support COLR.

In case a) the VPLMN must apply the COLR subscription as indicated by the data sent by the HPLMN.

In case b) the VPLMN must not apply COLR.

In case c) the VPLMN must apply an implicit COLR subscription.

To allow the VPLMN to make this distinction, the HLR and VLR behave as follows:

- If the HLR supports COLR, but COLR is not provisioned for the subscriber, the HLR shall inform the VLR that COLR is not provisioned.
- If the VLR supports COLR, but the HLR does not support COLR, the VLR shall behave in the same way as if COLR was provisioned for the subscriber, i.e. the connected line identity shall not be displayed to the calling subscriber unless the calling subscriber has COLR override capability. When interrogating the service status the subscriber shall be informed that COLR is provided to him and is active.

Annex A (informative): Mapping of CLI

This annex defines the mapping rules of CLI parameters received via the NW-NW interface to CLI parameters to be sent to the MS.

	Information received over the NW-NW interface					Information sent to the MS		
	presentation indicator	line identity	additional presentation indicator	additional line identity	Cause of No CLI	presentation indicator	line identity	Cause of No CLI
CLIP not provisioned	*	*	*	*	*	-	-	-
CLIP provisioned without override category	-	-	-	-	-	not available	-	-
	not available	-	-	-	-	not available	-	-
	allowed	digits	-	-	-	allowed	digits of line identity	-
	allowed	digits	+	digits	-	allowed	digits of additional line identity	-
	restricted	digits	*	*	-	restricted	-	-
	restricted	digits	*	*	unavailable	restricted	-	unavailable
	restricted	digits	*	*	reject by user	restricted	-	reject by user
	restricted	digits	*	*	interaction with other service	restricted	-	interaction with other service
	restricted	digits	*	*	payphone	restricted	-	payphone
	restricted by network	digits	-	-	-	not available	-	-
restricted by network	digits	allowed	digits	-	allowed	digits of additional line identity	-	

	Information received over the NW-NW interface					Information sent to the MS		
	presentation indicator	line identity	additional presentation indicator	additional line identity	Cause of No CLI	presentation indicator	line identity	Cause of No CLI
CLIP provisioned with override category	-	-	-	-	-	not available	-	-
	not available	-	-	-	-	not available	-	-
	allowed	digits	-	-	-	allowed	digits of line identity	-
	allowed	digits	+	digits	-	allowed	digits of additional line identity	-
	restricted	digits	-	-	-	restricted	digits of line identity	-
	restricted	digits	+	digits	-	restricted	NOTE 1	-
	restricted	digits	+	digits	unavailable	restricted	NOTE 1	unavailable
	restricted	digits	+	digits	reject by user	restricted	NOTE 1	reject by user
	restricted	digits	+	digits	interaction with other service	restricted	NOTE 1	interaction with other service
	restricted	digits	+	digits	payphone	restricted	NOTE 1	payphone
	restricted	digits	-	-	unavailable	restricted	digits of line identity	unavailable
	restricted	digits	-	-	reject by user	restricted	digits of line identity	reject by user
	restricted	digits	-	-	interaction with other service	restricted	digits of line identity	interaction with other service
	restricted	digits	-	-	payphone	restricted	digits of line identity	payphone
	restricted by network	digits	-	-	-	restricted	digits of line identity	-
restricted by network	digits	allowed	digits	-	allowed	digits of additional line identity	-	

- parameter not present

* parameter absent or present, if present it may have any value

+ parameter present, it may have any value

NOTE 1: Network Option to send either digits of the line identity or digits of additional line identity applies.

Annex B (informative): Change history

Change history						
TSG CN#	Spec	Version	CR	<Phase>	New Version	Subject/Comment
Apr 1999	GSM 03.81	7.0.0				Transferred to 3GPP CN1
CN#03	23.081			R99	3.0.0	Approved at CN#03
	23.081	3.0.0		R99	3.0.1	Upgrade of references from 2G to 3G
CN#08	23.081	3.0.1		R99	3.1.0	Enhanced handling of presentation indicators for CLIP
CN#11	23.081	3.1.0		Rel-4	4.0.0	Release 4 after CN#11
CN#16	23.081	4.0.0		Rel-5	5.0.0	Release 5 after CN#16
CN#17	23.081	5.0.0	0006	Rel-5	5.1.0	Correction of 'Cause of no CLI' handling in SDLs
CN#19	23.081	5.1.0	0007r1	Rel-5	5.2.0	Correction to interworking between CLIP enhancement and CAMEL
CN#25	23.081	5.2.0	0008	Rel-6	6.0.0	Editorial correction of table definition
CT#36	23.081	6.0.0		Rel-7	7.0.0	Upgraded unchanged from Rel-6
CT#42	23.081	7.0.0		Rel-8	8.0.0	Upgraded unchanged from Rel-7
CT#46	-	8.0.0	-	Rel-9	9.0.0	Update to Rel-9 version (MCC)
2011-03	-	9.0.0	-	Rel-10	10.0.0	Update to Rel-10 version (MCC)
2011-12	23.081	10.0.0	0009	Rel-11	11.0.0	CLI interactions with ACR