

3GPP TS 23.016 V11.0.0 (2012-09)

Technical Specification

**3rd Generation Partnership Project;
Technical Specification Group Core Network and Terminals;
Subscriber data management;
Stage 2
(Release 11)**



The present document has been developed within the 3rd Generation Partnership Project (3GPPTM) and may be further elaborated for the purposes of 3GPP.

The present document has not been subject to any approval process by the 3GPP Organizational Partners and shall not be implemented. This Specification is provided for future development work within 3GPP only. The Organizational Partners accept no liability for any use of this Specification. Specifications and reports for implementation of the 3GPPTM system should be obtained via the 3GPP Organizational Partners' Publications Offices.

Keywords

UMTS, network, subscriber, management

3GPP

Postal address

3GPP support office address

650 Route des Lucioles - Sophia Antipolis
Valbonne - FRANCE
Tel.: +33 4 92 94 42 00 Fax: +33 4 93 65 47 16

Internet

<http://www.3gpp.org>

Copyright Notification

No part may be reproduced except as authorized by written permission.
The copyright and the foregoing restriction extend to reproduction in all media.

© 2012, 3GPP Organizational Partners (ARIB, ATIS, CCSA, ETSI, TTA, TTC).
All rights reserved.

UMTS™ is a Trade Mark of ETSI registered for the benefit of its members
3GPP™ is a Trade Mark of ETSI registered for the benefit of its Members and of the 3GPP Organizational Partners
LTE™ is a Trade Mark of ETSI currently being registered for the benefit of its Members and of the 3GPP Organizational Partners
GSM® and the GSM logo are registered and owned by the GSM Association

Contents

Foreword	4
1 Scope	5
2 References.....	5
3 Definitions and abbreviations	6
3.1 Abbreviations.....	6
3.2 Definitions	7
4 General on handling of subscriber information	10
4.1 Updating of the VLR or the SGSN in framed operation	11
4.2 Updating of VLR and the SGSN in stand alone operation.....	12
4.2.1 Insertion of data in the VLR or the SGSN	12
4.2.2 Deletion of data in the VLR or the SGSN	13
4.2.3 Change of data in the VLR or in the SGSN.....	13
4.3 Order of information and distribution over message boundaries	13
4.3.1 Order of information sent by the HLR	13
4.3.2 Order of information received by the VLR or the SGSN.....	14
4.4 Abstract data structure of shared subscriber data.....	14
4.5 Handling of supplementary service data with respect to basic service data.....	15
4.5.1 General	15
4.5.2 Changes to basic service subscription	15
4.5.3 Special rules for BS61 and BS81 "alternate" and "followed-by" services.....	16
4.5.4 Consistency of Supplementary Service data	16
Annex A (informative): Change history.....	32

Foreword

This Technical Specification has been produced by the 3rd Generation Partnership Project (3GPP).

The contents of the present document are subject to continuing work within the TSG and may change following formal TSG approval. Should the TSG modify the contents of the present document, it will be re-released by the TSG with an identifying change of release date and an increase in version number as follows:

Version x.y.z

where:

- x the first digit:
 - 1 presented to TSG for information;
 - 2 presented to TSG for approval;
 - 3 or greater indicates TSG approved document under change control.
- y the second digit is incremented for all changes of substance, i.e. technical enhancements, corrections, updates, etc.
- z the third digit is incremented when editorial only changes have been incorporated in the document.

1 Scope

This specification gives the stage 2 description of the subscriber data management handling between:

- the Home Location Register (HLR) and the Visitor Location Register (VLR);
- the Home Location Register (HLR/HSS) and the Serving GPRS Support Node (SGSN).

A number of procedures require updating of subscriber information:

- location updating;
- restoration;
- modification of data by the operator;
- modification of data by the subscriber via the Mobile Station (MS).

Updating of subscriber information from HLR/HSS to SGSN is required in the following situations:

- GPRS location updating;
- EPS location updating;
- modification of data by the operator.

Only the rules for the updating of subscriber data from the HLR to the VLR and from the HLR/HSS to the SGSN are described in this specification; these rules only apply when the MAP protocol is used for subscriber data updating (see 3GPP TS 29.002 [23]). Public Land Mobile Network (PLMN) specific and Unstructured Supplementary Service Data (USSD) subscriber data are out of scope of this specification. The GPRS context update from the SGSN to the GGSN and the EPC bearer context update from the SGSN to the P-GW via S-GW are out of scope of this specification.

NOTE: The term 'HLR' should be read 'HLR/HSS' throughout the document.

2 References

The following documents contain provisions which, through reference in this text, constitute provisions of the present document.

- References are either specific (identified by date of publication, edition number, version number, etc.) or non-specific.
- For a specific reference, subsequent revisions do not apply.
- For a non-specific reference, the latest version applies. In the case of a reference to a 3GPP document (including a GSM document), a non-specific reference implicitly refers to the latest version of that document *in the same Release as the present document*.

- [1] 3GPP TS 21.905: "Vocabulary for 3GPP Specifications".
- [2] 3GPP TS 22.002: "Circuit Bearer Services (BS) supported by a Public Land Mobile Network (PLMN)".
- [3] 3GPP TS 22.004: "General on supplementary services".
- [4] 3GPP TS 23.007: "Restoration procedures".
- [5] 3GPP TS 23.008: "Organization of subscriber data".
- [6] 3GPP TS 23.011: "Technical realization of Supplementary Services".
- [7] 3GPP TS 23.015: "Technical realization of Operator Determined Barring (ODB)".

- [8] 3GPP TS 23.060: "General Packet Radio Service (GPRS) Service description; Stage 2".
- [9] 3GPP TS 23.067: "Enhanced Multi-Level Precedence and Preemption service (EMLPP); Stage 2".
- [10] 3GPP TS 23.078: "Customized Applications for Mobile network Enhanced Logic (CAMEL) phase 3 - Stage 2".
- [11] 3GPP TS 23.081: "Line identification supplementary services; Stage 2".
- [12] 3GPP TS 23.082: "Call Forwarding (CF) Supplementary Services; Stage 2".
- [13] 3GPP TS 23.083: "Call Waiting (CW) and Call Hold (HOLD) Supplementary Services; Stage 2".
- [14] 3GPP TS 23.084: "Multi Party (MPTY) Supplementary Service; Stage 2".
- [15] 3GPP TS 23.085: "Closed User Group (CUG) Supplementary Service; Stage 2".
- [16] 3GPP TS 23.086: "Advice of Charge (AoC) Supplementary Service; Stage 2".
- [17] 3GPP TS 23.088: "Call Barring (CB) Supplementary Service; Stage 2".
- [18] 3GPP TS 23.090: "Unstructured Supplementary Service Data (USSD); Stage 2".
- [19] 3GPP TS 23.091: "Explicit Call Transfer (ECT) Supplementary Service; Stage 2".
- [20] 3GPP TS 23.093: "Technical realization of Completion of Calls to Busy Subscriber (CCBS); Stage 2".
- [21] 3GPP TS 23.096: "Name Identification Supplementary Service; Stage 2".
- [22] 3GPP TS 23.116: "Super-Charger technical realization; Stage 2".
- [23] 3GPP TS 29.002: "Mobile Application Part (MAP) specification".
- [24] 3GPP TS 29.060: "General Packet Radio Service (GPRS); GPRS Tunnelling Protocol (GTP) across the Gn and Gp Interface".
- [25] 3GPP TS 22.001: "Principles of circuit telecommunications services supported by a Public Land Mobile Network (PLMN)".
- [26] 3GPP TS 22.003: "Circuit Teleservices supported by a Public Land Mobile Network (PLMN)".
- [27] 3GPP TS 42.032: "Immediate Service Termination (IST); Service Description - Stage 1".
- [28] 3GPP TS 43.035: "Immediate Service Termination (IST); Stage 2".
- [29] 3GPP TS 43.068: "Voice Group Call Service (VGCS); Stage 2".
- [30] 3GPP TS 43.069: "Voice Broadcast Service (VBS); Stage 2".
- [31] 3GPP TS 23.071: "Location Services (LCS); Functional Description; Stage 2".
- [32] 3GPP TS 23.135: "Multicall supplementary service; Stage 2".
- [33] 3GPP TS 23.072: "Call Deflection Supplementary Service; Stage 2".
- [34] 3GPP TS 23.012: "Location Management Procedures".

3 Definitions and abbreviations

3.1 Abbreviations

For the purposes of the present document, the abbreviations given in 3GPP TS 21.905 apply.

3.2 Definitions

Subscriber data to be stored in the HLR, VLR and SGSN are defined in 3GPP TS 23.008, 3GPP TS 23.271, 3GPP TS 23.135 and in 3GPP TS 23.06x, 3GPP TS 23.08x and 3GPP TS 23.09x-series of technical specifications.

Voice Broadcast Service (VBS), Voice Group Call Service (VGCS) and enhanced Multi Level Precedence and Pre-emption Service (eMLPP) Data related to group call area, cell or dispatcher attributes is only stored in the Group Call Register (GCR) which is linked to each MSC/VLR.

The GCR and its stored data is out of scope of this specification.

Subscriber related VBS, VGCS and eMLPP Data only concerns entitlement data for these-services and is seen as shared non-GPRS subscriber data.

GPRS and non-GPRS subscriber data:

The HLR has to download data to the VLR and to the SGSN. In this specification those data sent to the VLR are called non-GPRS subscriber data and those data sent to the SGSN are called GPRS subscriber data.

Whenever the refining identifier non-GPRS or GPRS is missing a common rule is addressed which hold for both kinds of subscriber data.

Subscriber data specific to non-GPRS shall only be sent from the HLR to the VLR. Subscriber data specific to GPRS shall only be sent from the HLR to the SGSN.

Subscriber data common to both non-GPRS and GPRS (regional subscription information) are downloaded from the HLR to both entities.

Shared non-GPRS subscriber data: Common subset of subscriber data defined to be stored in both the HLR and VLR. Subscriber data only stored in the HLR is not part of shared subscriber data. Shared subscriber data includes:

- BS: Bearer Service (see 3GPP TS 22.002);
- TS: Teleservice (see 3GPP TS 22.003);
- BSG: Basic Service Group (see 3GPP TS 22.001, 3GPP TS 22.004 and 3GPP TS 23.011);
- EBSG: Elementary Basic Service Group (see 3GPP TS 23.011);
- CBSG: Collective Basic Service Group (see 3GPP TS 23.011);
- LSA Information: Localized Service Area Information (see 3GPP TS 23.073);
- SC Information: Super-Charger Information (see 3GPP TS 23.116);
- IST Information: Immediate Service Termination Information (see 3GPP TS 43.035).

Shared GPRS subscriber data: Common subset of subscriber data defined to be stored in both the HLR and SGSN. Subscriber data only stored in the HLR is not part of shared subscriber data. Shared GPRS subscriber data includes:

- TS: Teleservice (see 3GPP TS 22.003);
- PDP Context (see 3GPP TS 23.060);
- LSA Information: Localized Service Area Information (see 3GPP TS 23.073);
- SC Information: Super-Charger Information (see 3GPP TS 23.116);
- Charging Information (see 3GPP TS 23.060).

Mandatory data: Data required to form a self-consistent set of subscriber data. The context governs whether a specific parameter is mandatory, e.g. the data set for a specific service may be optional, however if data for this service is present, then parameters within this data set may be mandatory.

Mandatory data is defined by the service description (see e.g. 3GPP TS 23.06x, 3GPP TS 23.08x and 3GPP TS 23.09x-series of technical specifications, 3GPP TS 23.015, 3GPP TS 23.071 and 3GPP TS 23.135) and by PLMN defined requirements.

NOTE: The above definition is seen from a semantic point of view. Semantically, mandatory parameters may be defined as syntactically optional or mandatory by the protocol.

Optional data: Data which is defined as subscriber data, but which is not required to form a self-consistent set of subscriber data; the context governs whether a specific parameter is optional.

Optional data is data which is defined by the service description (see e.g. 3GPP TS 23.06x, 3GPP TS 23.08x and 3GPP TS 23.09x-series of technical specifications, 3GPP TS 23.015, 3GPP TS 23.271 and 3GPP TS 23.135) or by PLMN defined requirements but is not defined as mandatory data.

NOTE: The above definition is seen from a semantic point of view. Semantically optional parameters are always defined as syntactically optional by the protocol.

Missing data: Data which is mandatory in a given context but is not received nor is valid data available locally.

Unexpected data: Data which is received and cannot be further processed. This may be either:

- optional data not required in a given context; or
- optional or mandatory data, required in this context but received with an unexpected value.

Overlapping data: Two different cases of overlapping within subscriber data are possible:

- two or more parameters are to be stored at the same address in the data structure (see subclause 4.4);
- two or more BSGs within a BSG list include or are identical with one and the same EBSG.

The following groups of non-GPRS subscriber information are defined:

- Subscriber information (Group A):
 - International Mobile Subscriber Identity (IMSI);
 - basic Mobile Station International ISDN Number (MSISDN);
 - category;
 - subscriber status;
 - LMU identifier (GSM only).
- Basic service information (Group B):
 - Bearer Service list;
 - Teleservice list.

NOTE: VBS and VGCS entitlement data are subsumed under Teleservices.

- Supplementary Service (SS) information (Group C):
 - forwarding information including deflection information;
 - call barring information;
 - Closed User Group (CUG) information;
 - eMLPP data;
 - MC data;
 - SS Data.
- Operator Determined Barring (ODB) information (Group D):
 - ODB Data for non-GPRS services;
- Roaming restriction information (Group E):

- roaming restriction due to unsupported feature.
- Regional subscription information (Group F):
 - regional subscription data.
- VBS/VGCS subscription information (Group G):
 - VBS subscription data;
 - VGCS subscription data.
- CAMEL subscription information (Group H):
 - Originating CAMEL Subscription Information (O-CSI);
 - Dialed Service CAMEL Subscription Information (D-CSI);
 - VMSC Terminating CAMEL Subscription Information (VT-CSI);
 - Supplementary Service Invocation Notification CAMEL Subscription Information (SS-CSI);
 - Translation Information Flag CAMEL Subscription Information (TIF-CSI);
 - Mobile Originating Short Message Service CAMEL Subscription Information (MO-SMS-CSI);
 - Mobile Terminating Short Message Service CAMEL Subscription Information (MT-SMS-CSI);
 - Mobility Management Event Notification CAMEL Subscription Information (M-CSI).
- LSA Information (Group I):
 - LSA data.
- Super-Charger (SC) Information (Group K):
 - Age Indicator.
- Location Services (LCS) information (Group X):
 - GMLC List;
 - LCS Privacy Exception List;
 - MO-LR List;
 - LCS Service Types.
- IST Information (Group J):
 - IST data.
- Bearer Service Priority Information (Group L):
 - Bearer Service Priority Data.
- Administrative Restriction Information (Group M):
 - Access Restriction Data.

The following groups of GPRS subscriber information are defined:

- Subscriber information (Group P1):
 - International Mobile Subscriber Identity (IMSI);
 - basic Mobile Station International ISDN Number (MSISDN);
 - subscriber status.

- Basic service information (Group P2):
 - Teleservice list.
- Operator Determined Barring (ODB) information (Group P3):
 - ODB Data for GPRS services.
- Roaming restriction information (Group P4):
 - roaming restriction in SGSN due to unsupported feature.
- Regional subscription information (Group P5):
 - regional subscription data.
- GPRS subscription information (Group P6):
 - GPRS subscription data.
- EPS subscription information (Group P6a):
 - EPS subscription data.
- SGSN CAMEL subscription information (Group P7):
 - GPRS CAMEL subscription information;
 - Mobile Originating Short Message Service CAMEL Subscription Information (MO-SMS-CSI);
 - Mobile Terminating Short Message Service CAMEL Subscription Information (MT-SMS-CSI);
 - Mobility Management Event for GPRS Notification CAMEL Subscription Information (MG-CSI).
- LSA Information (Group P8):
 - LSA data.
- Super-Charger (SC) Information (Group P9):
 - Age Indicator.
- Charging Information (Group P10):
 - Subscribed Charging Characteristics.
- Location Services (LCS) information (Group P11):
 - GMLC List;
 - LCS Privacy Exception List;
 - MO-LR Lis;
 - LCS Service Types.
- Administrative Restriction Information (Group P12):
 - Access Restriction Data.

4 General on handling of subscriber information

In general, the VLR and SGSN stores only a subset of the subscriber data available in the HLR. Similarly, the GGSN stores only a subset of the subscriber data available in the SGSN. Updating of subscriber information shall be done in a way to make available and to keep consistency of data shared between the HLR and the VLR, and between the HLR and the SGSN as appropriate.

Two different cases for the updating of subscriber data can be identified:

1. framed operation: during location update or restoration a complete set of the shared subscriber data needs to be inserted in the VLR or the SGSN;
2. stand-alone operation: whenever subscriber data are added, deleted or changed in the HLR, this may need partial insertion, deletion or change of shared subscriber data in the VLR or the SGSN.

Subclauses 4.1 to 4.4 explain the actions of the HLR and the VLR or the SGSN within a framed or stand-alone dialogue on subscriber data handling.

4.1 Updating of the VLR or the SGSN in framed operation

For some services the VLR or the SGSN shall indicate in the subscriber data request to the HLR whether it supports the service, or (in case of a service with multiple phases) which phases it supports. Whether or not this indication is required for the service is defined in service specification.

If requested by the framing operation, the HLR shall send all relevant stored shared subscriber data to the VLR or the SGSN. This may be done with one or more messages within a single dialogue.

For services for which the VLR or the SGSN is required to indicate support of the service, the HLR shall send subscriber data to the VLR or the SGSN only if corresponding indication was received from the VLR or the SGSN in the subscriber data request. If both the originating entity and the HLR support the Super-Charger functionality the HLR may provide no subscriber data as part of the location update procedure, see 3GPP TS 23.116. For control of stand-alone operation the HLR shall store the information for which of these services the subscriber data was sent.

For services for which the VLR or the SGSN is required to indicate supported phases of the service, the HLR shall send subscriber data to the VLR for at most one of the supported phases of service indicated in the subscriber data request. In this case the HLR may send also no data at all if none of the supported phases is suitable. For the case of stand-alone operation the HLR shall store the information for which phase of service the data was sent.

The HLR may send all stored shared subscriber data to the VLR or the SGSN with one or more messages within a single dialogue.

The VLR or the SGSN shall check the received messages, and:

- a) if mandatory data is missing in a message:
 - the VLR or the SGSN may immediately reject the message towards the HLR; or
 - the VLR or the SGSN may acknowledge the message towards the HLR and wait for further data from the HLR.

NOTE: Which of the two options apply is either defined by the protocol specification or is an implementation option.

- b) if unexpected data are received in a message:
 - the VLR or the SGSN may reject the message towards the HLR; or
 - in case of unexpected data not required in a given context, the VLR or the SGSN may acknowledge the message towards the HLR and ignore this unexpected data. All other data shall be stored by the VLR or the SGSN.

NOTE: Which of the two possibilities apply is an implementation option.

- c) if data for unsupported services or features is received:
 - the VLR or the SGSN shall respond towards the HLR to the message indicating these features and shall ignore all received data related to them. All other subscriber data shall be stored;
- d) if cases a), b) and c) do not apply for a message, the VLR or SGSN shall store all subscriber data received.

If during the entire dialogue none of the messages was rejected by the VLR or the SGSN and at termination of the dialogue no mandatory subscriber data are missing, the VLR or the SGSN shall erase all previously stored data and

shall store the data received from the HLR and mark the subscriber data as "confirmed by HLR". Otherwise the subscriber data shall remain marked as "not confirmed by HLR" (see TS 3GPP TS 23.007).

The HLR shall check all responses from the VLR or the SGSN, and:

- a) if a message is rejected, no further updating of the VLR or the SGSN shall occur. The further action on the framing operation is out of scope of this specification;
- b) if one or more unsupported features are indicated by the VLR or the SGSN, the HLR may:
 - store subscriber data including replacement feature(s) locally;
 - store and send subscriber data including replacement feature(s);
 - ignore this indication.

NOTE: Which of the three options apply for which feature is out of scope of this specification

- c) if a message is acknowledged by the VLR or the SGSN, this shall be recognized by the HLR.

The further action on the framing operation after all shared subscriber and replacement data have been sent (e.g. closing of the dialogue) is out of scope of this specification.

4.2 Updating of VLR and the SGSN in stand alone operation

If shared subscriber data are added, deleted or changed in the HLR, the HLR shall insert or delete this subscriber data in the VLR or the SGSN to keep consistency of data stored.

For services for which the VLR or the SGSN is required to indicate support of the service in the request, the HLR shall insert or delete this subscriber data in the VLR or the SGSN only if an appropriate indication is stored in the HLR (see subclause 4.1).

For services for which the VLR or the SGSN is required to indicate supported phases of the service in the request, the HLR shall insert or delete subscriber data in the VLR or the SGSN only if it was added, deleted or changed for the phase of the service for which the data was sent to the VLR or the SGSN in the framed operation.

4.2.1 Insertion of data in the VLR or the SGSN

For the insertion of data, the HLR may send one or more messages in a single dialogue.

The VLR or the SGSN shall check the received data, and:

- a) if mandatory data is missing in a message:
 - the VLR or the SGSN may reject the message towards the HLR; or
 - the VLR or the SGSN may acknowledge the message towards the HLR and wait for further data from HLR.

NOTE: Which of the two possibilities apply is either defined by the protocol specification or an implementation option.

- b) if unexpected data are received:
 - the VLR or the SGSN may reject the message towards the HLR; or
 - in case of unexpected data not required in a given context, the VLR or the SGSN may acknowledge the message towards the HLR and ignore this unexpected data. All other data shall be stored by the VLR or the SGSN.

NOTE: Which of the two possibilities apply is an implementation option.

- c) if data for unsupported services or features is received:
 - the VLR or the SGSN shall respond towards the HLR to the message indicating these features and shall ignore all data assigned to them. All other subscriber data shall be stored.

d) if cases a), b) and c) do not apply for a message, the VLR or the SGSN shall store all subscriber data received.

If during the entire dialogue none of the messages was rejected by the VLR or the SGSN and at termination of the dialogue no subscriber data are missing, the VLR or the SGSN shall mark the subscriber data as "confirmed by HLR". Otherwise the subscriber data shall be marked as "not confirmed by HLR" (see 3GPP TS 23.007).

The HLR shall check all responses from the VLR or the SGSN, and:

- a) if a message is rejected no further updating of the VLR or the SGSN is allowed and the HLR shall terminate the dialogue;
- b) if one or more unsupported features are indicated by the VLR or the SGSN, the HLR may:
 - store subscriber data including replacement feature(s) locally;
 - store and send subscriber data including replacement feature(s);
 - ignore this indication.

NOTE: Which of the three possibilities apply for which feature is out of scope of this specification

- c) if a message is acknowledged by the VLR or the SGSN, this shall be recognized by the HLR.

After all required shared subscriber and replacement data have been sent, the HLR shall terminate the dialogue with the VLR or the SGSN.

4.2.2 Deletion of data in the VLR or the SGSN

Deletion needs a separate dialogue.

HLR and VLR or SGSN actions are the same as above except for the following case:

- if, in response to deletion, one or more unsupported features are indicated by the VLR or the SGSN, the HLR may:
 - delete subscriber data including replacement feature(s) locally;
 - delete subscriber data including replacement feature(s) locally and in the VLR or the SGSN (NOTE);
 - take no further action.

NOTE 1: Which of the three options apply for which feature is out of scope of this specification.

NOTE 2: This deletion in the VLR or the SGSN needs a separate dialogue.

The VLR or SGSN shall terminate the dialogue VLR or SGSN the response to the HLR.

4.2.3 Change of data in the VLR or in the SGSN

If existing data in the VLR or the SGSN is to be modified, the HLR may insert the replacing data, which overwrites the existing data according to the rules described in subclause 4.4. Alternatively, the HLR may delete the existing data as described in subclause 4.2.2 and then insert the replacing data as described in subclause 4.2.1.

4.3 Order of information and distribution over message boundaries

4.3.1 Order of information sent by the HLR

The order of information is defined by the order in which the transfer syntax is generated by the HLR. This includes a sequence of messages as well as the syntax within a message (first to last message, component, operation, parameter, etc...).

With the above definitions, the following rules shall apply for non-GPRS subscriber data for the order of information within an HLR-VLR dialogue:

- Group A information (subscriber status) shall be sent first;
- Group B information shall be sent after Group A information and before any Group C, E, F, G, H, J, L, M or X information;
- Group D information shall be sent after Group A information and in any order with respect to Group B, C, E, F, G, H, J, K, L, M and X information;
- a specific order of Group C, E, F, G, H, J, K, L, M or X information is not required.

There is no requirement for the sending of subscriber information groups in the same message.

With the above definitions, the following rules shall apply for GPRS subscriber data for the order of information within a dialogue:

- Group P1 information (subscriber status) shall be sent first;
- Group P2 information shall be sent after P1 information and before P4 and P5 information;
- Group P3 information shall be sent after Group P1 information and in any order with respect to Group P2, P4, P5, P6, P6a, P7, P8, P11 and P12 information;
- a specific order of Group P4, P5, P6, P6a, P9, P10, P11 and P12 information is not required.

4.3.2 Order of information received by the VLR or the SGSN

Normally, the order of information sent and received shall be identical. However, if subscriber data are sent distributed over several messages within a dialogue in exceptional cases the order of these messages may change during transmission.

If the order of information received violates the rules given above, the VLR or the SGSN has the following options:

- the VLR or the SGSN rejects all messages which cannot be processed due to violation of these rules. In this case, checking of missing mandatory parameters is done for each message;
- the VLR or the SGSN processes and accepts all received messages although rules are violated. In this case, checking of missing mandatory parameters is done after the last message i.e. after termination of the dialogue.

Both options may be used in a single implementation. Missing parameters may be detected during the dialogue. For other parameters, the checking is done after termination of the dialogue between the HLR and the VLR or the SGSN.

The VLR or the SGSN is not required to handle received data in a specific order. As a consequence, any overlapping of data within a dialogue should be avoided to keep consistency of data between HLR and VLR or the SGSN. If the VLR or SGSN indicates that it does not support a feature or service, the HLR may send data for a feature or service to replace the unsupported one. If the data of that service or feature had already been sent, this shall not be regarded as overlapping data.

4.4 Abstract data structure of shared subscriber data

Figure 1 shows the general organization of the shared non-GPRS subscriber data stored in the HLR and VLR. Figure 2 shows the overall organization of subscriber data stored in HLR and SGSN. The figures 3 to 25 show the organization of the shared subscriber data stored in the HLR and VLR or in the HLR and SGSN. This structure is only valid for data stored in the registers and is not identical with the structure in the protocol, defining how data are transferred.

NOTE: This description is only a model for the logical structure and does not define the specific implementation of the data storage.

With this structure, the following general rules for the handling of subscriber data are defined:

- the root of this data tree is always the IMSI which identifies the subscriber;

- to address a specific parameter within this hierarchical tree, it is necessary to start from the IMSI and to go through the branches until the parameter is reached. The list of parameters met on the way defines the address of the parameter within the data structure;
- to delete or insert a specific parameter, the complete address information is required;
- if a parameter is inserted, all parameters in the address and the parameter itself shall be marked as present. A parameter value is stored irrespective of whether a value was already stored;
- if a parameter is deleted, all parameters connected to it in the sub-branches are also deleted i.e. they are marked as not present;
- if a parameter is overwritten with a new value, parameters connected to it in the sub-branches shall be set according to the rules of the individual service specification.

In addition to the general rules given above, special rules apply to certain specific subscriber data. This is out of scope of this specification (see references in the notes in figures 1 to 25).

4.5 Handling of supplementary service data with respect to basic service data

Some supplementary service data is qualified by Elementary Basic Service Group (EBSG) data. This part of the service data is below the parameter "BSG" in the abstract data hierarchy, and is referred to as the "EBSG-related SS data". This clause provides special rules for handling of EBSG-related SS data.

The internal representation of EBSGs and EBSG-related SS data in the HLR and VLR is outside the scope of this specification. For simplicity this description uses a model where all EBSG-related SS data is stored against individual EBSGs. Implementations may use alternative internal data structures.

4.5.1 General

EBSG-related SS data shall be stored in the HLR and VLR for all EBSGs that meet all the following criteria:

- at least one basic service in the EBSG is supported; and
- the supplementary service is applicable to at least one (possibly different) basic service in the EBSG; and
- the subscriber has a subscription to at least one (possibly different) basic service in the EBSG.

EBSG-related SS data shall not be stored for any other EBSGs.

For each service for which the HLR sends EBSG-related SS data to the VLR, the HLR shall send the data for all EBSGs that meet all the following criteria:

- at least one basic service in the EBSG is supported at the HLR; and
- the supplementary service is applicable to at least one (possibly different) basic service in the EBSG; and
- the subscriber has a subscription to at least one (possibly different) basic service in the EBSG.

At any time, if the HLR has to send identical EBSG-Related SS data for several EBSGs, then it may be able to represent a set of EBSGs by a collective basic service group (CBSG), or by omitting the EBSG information altogether. This is specified in detail in 3GPP TS 29.002.

4.5.2 Changes to basic service subscription

Changes to the basic service subscription can impact EBSG-related SS data.

If a new basic service is provisioned, and this is the first basic service to be provisioned for this subscriber in a particular EBSG, then the HLR shall update supplementary service data in the VLR if necessary. The HLR shall insert in the VLR EBSG-related SS data for the new EBSG for all supplementary services that:

- have EBSG-related SS data; and

- are applicable to at least one basic service in the new EBSG; and
- are in a state where the VLR should receive data (normally this means the service must be provisioned).

If a new basic service is provisioned, and this is not the first basic service provisioned for this subscriber in a particular EBSG, then the HLR is not required to send any new supplementary service data as a result.

If a basic service is withdrawn, and this was the last remaining basic service provisioned for this subscriber in a particular EBSG, then when they are informed about the withdrawal of the basic service the HLR and VLR shall locally delete any supplementary service data relating to that EBSG.

If a basic service is withdrawn, and this was not the last remaining basic service provisioned for this subscriber in a particular EBSG, then the HLR and VLR shall not make any changes to supplementary service data as a result.

4.5.3 Special rules for BS61 and BS81 "alternate" and "followed-by" services

There is no EBSG-related SS data for the groups BS61 and BS81 ("alternate" and "followed-by"). Instead, supplementary services related to these basic services are handled according to the bearer service group BS2x or BS3x corresponding to the data part of the "alternate" and "followed by" bearer service (see 3GPP TS 22.004). This means that special rules are required for subscribers with subscriptions to BS61 or BS81.

For the handling of EBSG-related SS data, a subscription to BS61 or BS81 shall be treated in the same way as a subscription to a basic service in each of the groups "all data circuit asynchronous" and "all data circuit synchronous" (BS2x and BS3x). If a user subscribes to BS61 or BS81 then the HLR shall send any relevant EBSG-related SS data to the VLR for the groups BS2x and BS3x even if the subscriber does not subscribe to any basic services in the groups BS2x and BS3x.

Examples:

- if a user who does not subscribe to any basic services in BS2x or BS3x is given a subscription to BS81 then the HLR updates the VLR with any relevant EBSG-related SS data for the groups BS2x and BS3x. If the subscription to BS81 is then withdrawn, the VLR locally deletes all EBSG-related SS data for BS2x and BS3x.
- if a user who has a subscription to BS21, but not to any basic services in BS3x is given a subscription to BS81 then the HLR updates the VLR with any relevant EBSG-related SS data for the group BS3x. If the subscription to BS81 is then withdrawn, the VLR locally deletes all EBSG-related SS data for BS3x (though not for BS2x).

EBSG-related SS data shall not be qualified by the groups BS61 or BS81.

4.5.4 Consistency of Supplementary Service data

In some cases, the protocol used between the HLR and VLR encodes some data that is not EBSG-related SS data with an EBSG qualifier. In this case, the HLR shall ensure that when this data is sent it is always the same for all EBSGs. If this data is modified, the HLR must send the supplementary service data to the VLR for all EBSGs which meet all the following criteria:

- at least one basic service in the EBSG is supported; and
- the supplementary service is applicable to at least one (possibly different) basic service in the EBSG; and
- the subscriber has a subscription to at least one (possibly different) basic service in the EBSG.

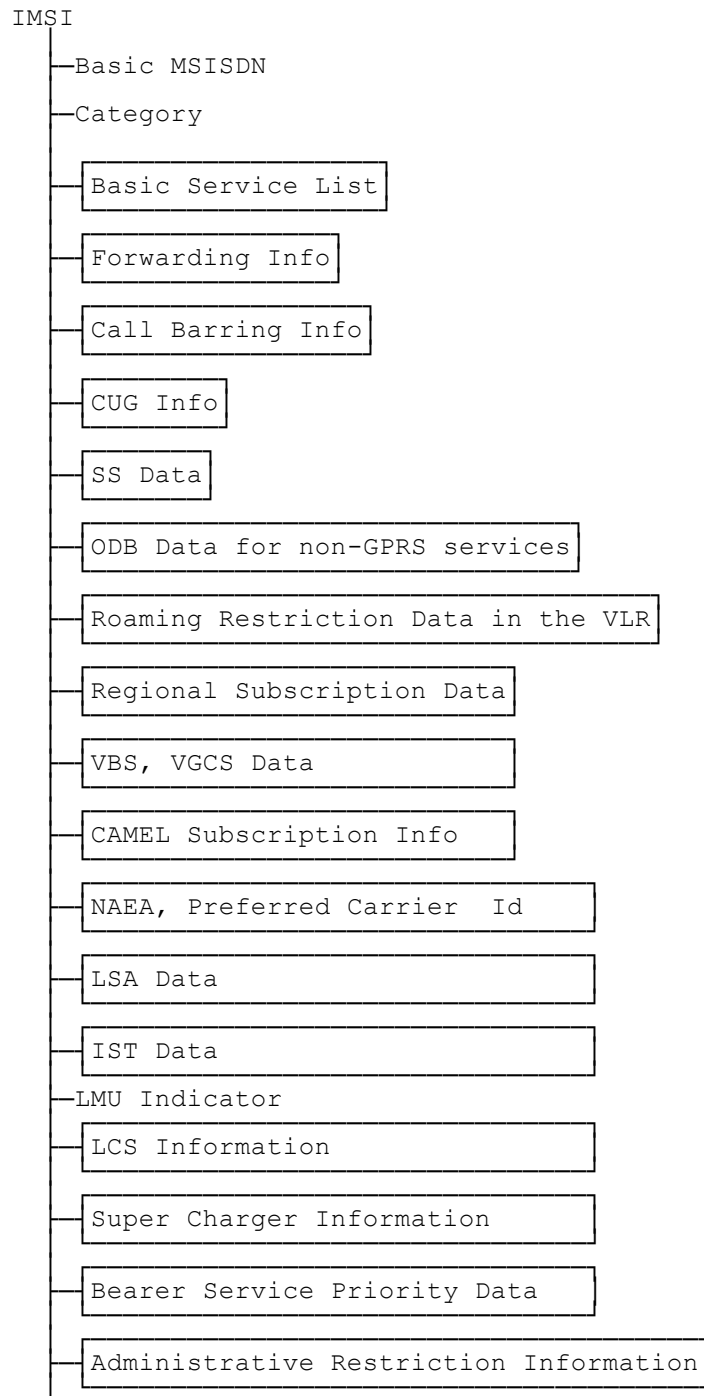

Figure 1: Abstract data structure of non-GPRS Subscriber Data (Data sent to the VLR)

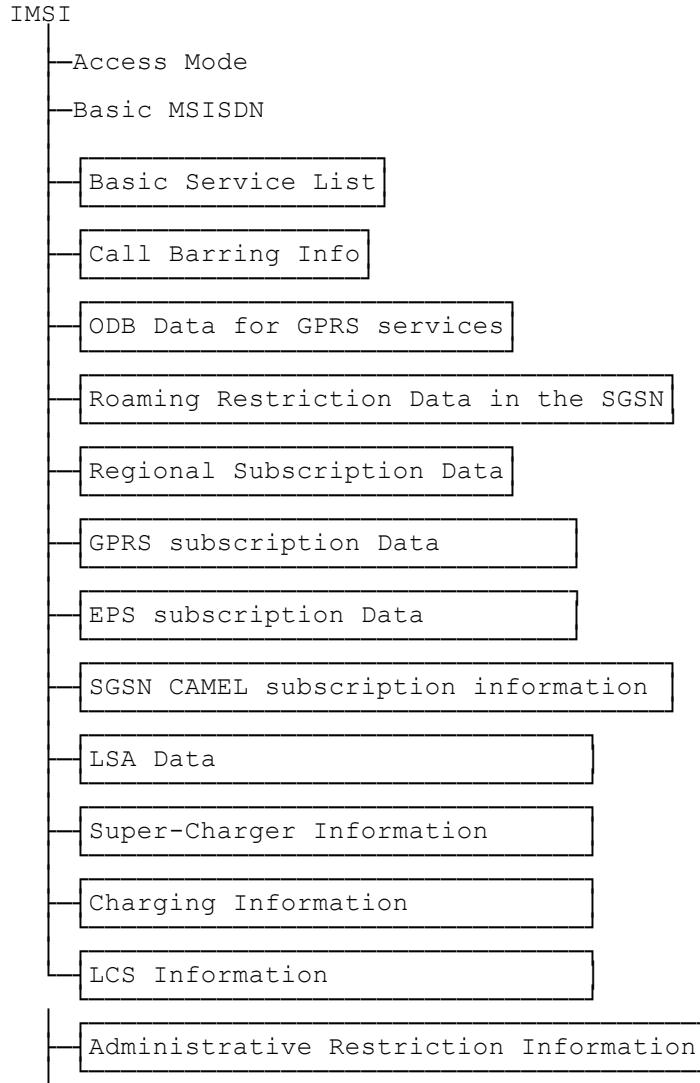
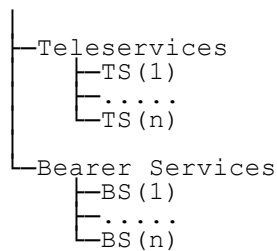
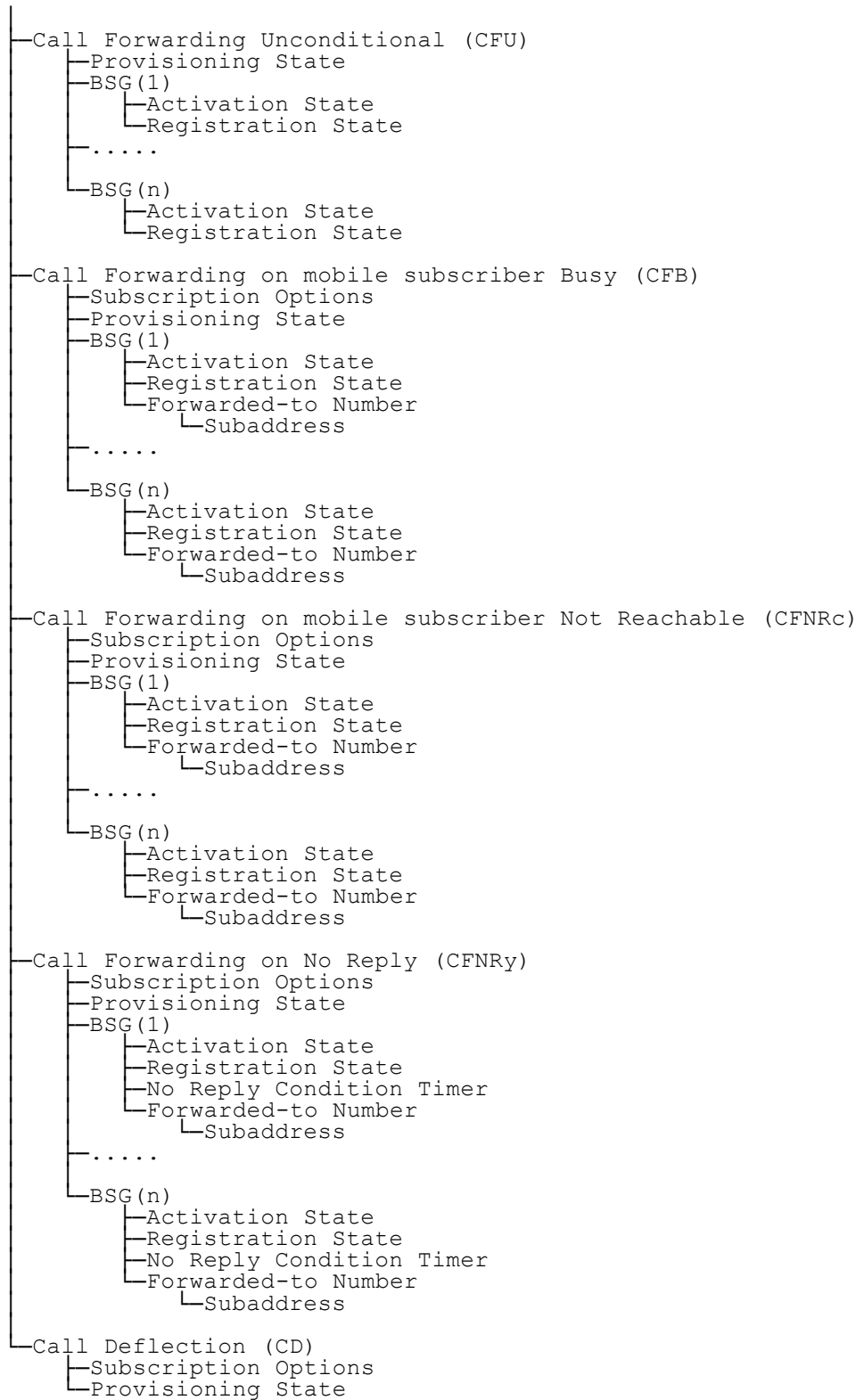

Figure 2: Abstract data structure of GPRS Subscriber Data (Data sent to the SGSN)



NOTE: For detailed information see 3GPP TS 22.001, 3GPP TS 22.002, 3GPP TS 22.003 and 3GPP TS 29.002.

Figure 3: Basic Service List



NOTE: For detailed information see 3GPP TS 23.072, 3GPP TS 23.082 and 3GPP TS 29.002.

Figure 4: Forwarding Info

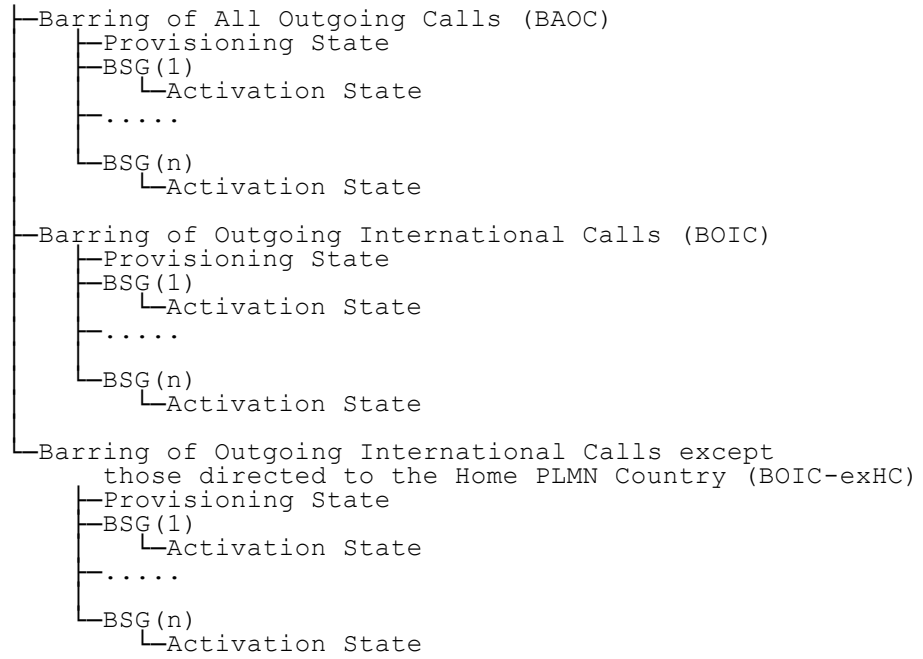

NOTE: For detailed information see 3GPP TS 23.088 and 3GPP TS 29.002.

Figure 5: Call Barring Info

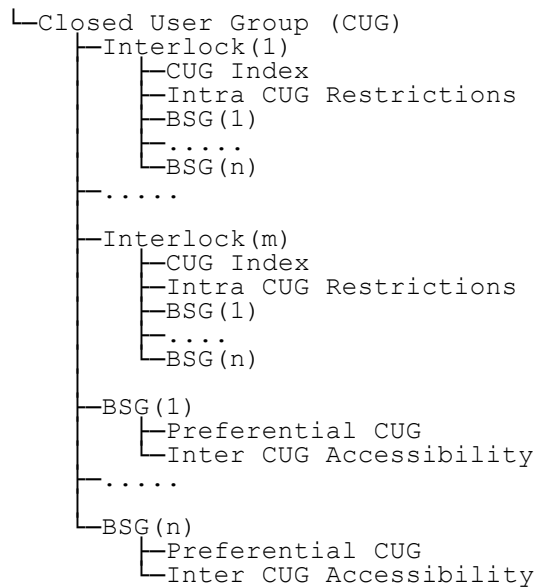

NOTE: For detailed information see 3GPP TS 23.085 and 3GPP TS 29.002.

Figure 6: CUG Info

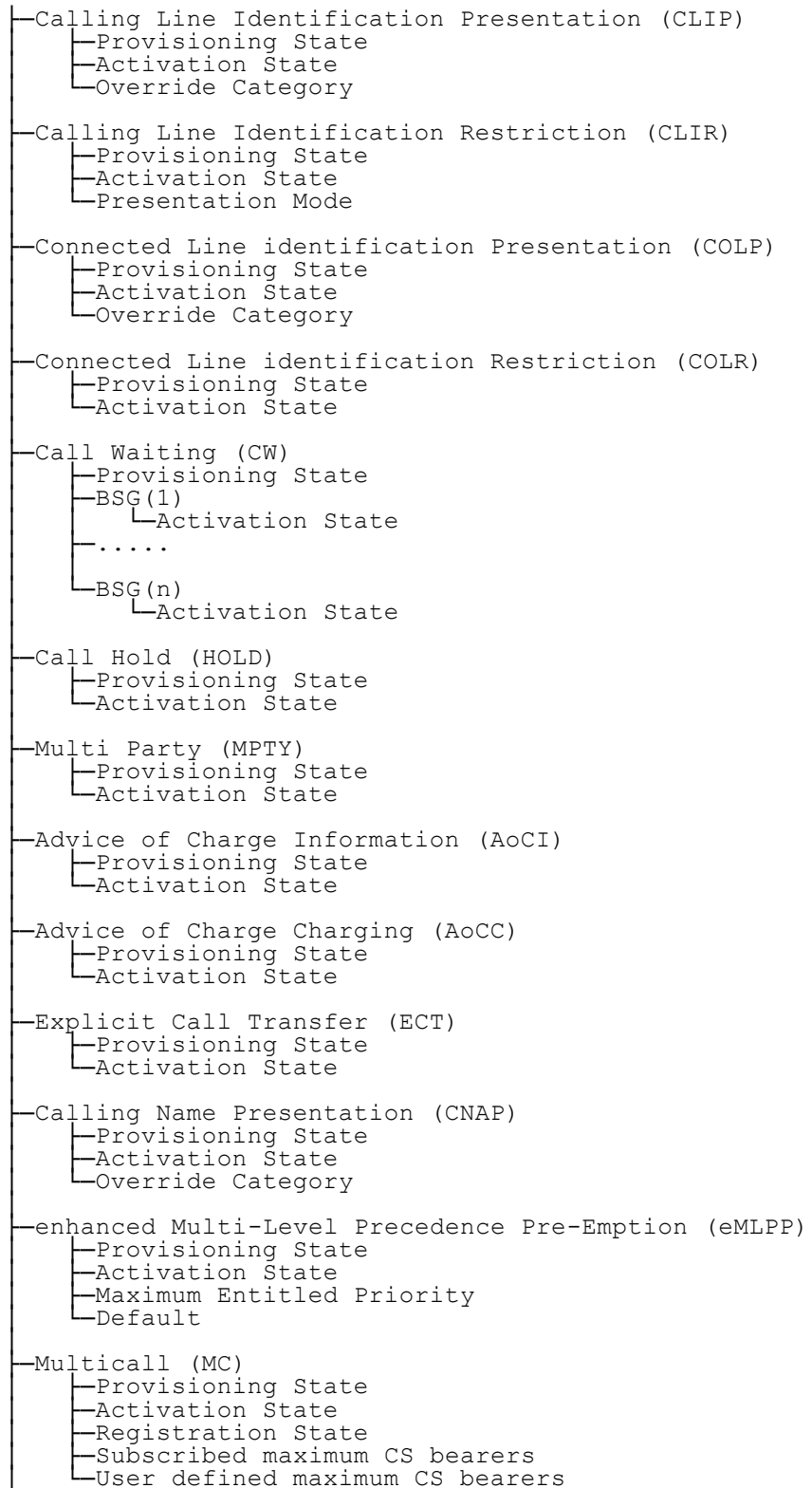

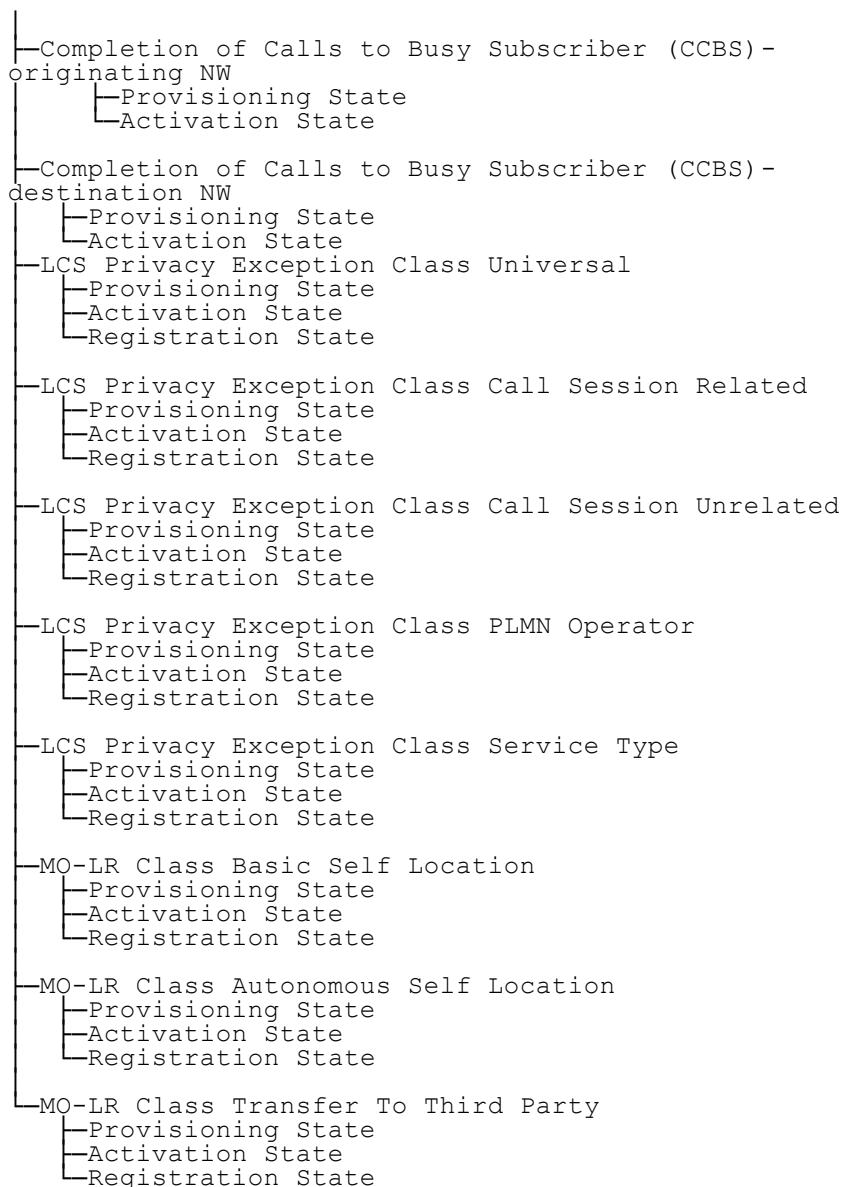

NOTE: For detailed information see 3GPP TS 23.067, 3GPP TS 23.081, 3GPP TS 23.083, 3GPP TS 23.084, 3GPP TS 23.086, 3GPP TS 23.091, 3GPP TS 23.093, 3GPP TS 23.096, 3GPP TS 23.135, 3GPP TS 29.002 and 3GPP TS 23.071.

The codes below are used for the single purpose of enabling the visited network to notify the home network whether or not the particular Supplementary Service is supported. These codes are also included in the LCS Information parameter and the visited network shall use the codes in the LCS Information parameter, and only this parameter, to obtain the information needed for the LCS Supplementary Service.

- LCS Privacy Exception Class Universal
- LCS Privacy Exception Class Call Session Related
- LCS Privacy Exception Class Call Session Unrelated
- LCS Privacy Exception Class PLMN Operator
- LCS Privacy Exception Class Service Type
- MO-LR Class Basic Self Location
- MO-LR Class Autonomous Self Location

- MO-LR Class Transfer To Third Party

Figure 7: SS Data

```

└Subscriber Status
  ├──all OG-Calls Barred
  ├──international OG-Calls Barred
  ├──international OG-Calls Not To HPLMN Country Barred
  ├──inter-zonal OG-Calls Barred
  ├──inter-zonal OG-Calls Not To HPLMN Country Barred
  ├──international OG-Calls Not To HPLMN Country AND
  │   inter-zonal OG-Calls Barred
  ├──Premium Rate Information OG-Calls Barred
  ├──Premium Rate Entertainment OG-Calls Barred
  ├──SS Access Barred
  ├──all call transfers Barred
  ├──chargeable call transfers Barred
  ├──international call transfers Barred
  ├──inter-zonal call transfers Barred
  ├──doubly chargeable call transfers Barred
  ├──multiple call transfers Barred
  ├──PLMN-Specific Barring Type 1
  ├──PLMN-Specific Barring Type 2
  ├──PLMN-Specific Barring Type 3
  └PLMN-Specific Barring Type 4
  
```

NOTE: For detailed information see 3GPP TS 23.015 and 3GPP TS 29.002.

Figure 8: ODB Data for non-GPRS services

```

└Subscriber Status
  ├──all OG-Calls Barred
  ├──international OG-Calls Barred
  ├──international OG-Calls Not To HPLMN Country Barred
  ├──inter-zonal OG-Calls Barred
  ├──inter-zonal OG-Calls Not To HPLMN Country Barred
  ├──international OG-Calls Not To HPLMN Country AND
  │   inter-zonal OG-Calls Barred
  ├──PLMN-Specific Barring Type 1
  ├──PLMN-Specific Barring Type 2
  ├──PLMN-Specific Barring Type 3
  ├──PLMN-Specific Barring Type 4
  ├──All Packet Oriented Services Barred
  ├──Roamer Access To HPLMN AP-Barred
  └Roamer Access To VPLMN AP-Barred
  
```

NOTE: For detailed information see 3G TS 23.015 and 3G TS 29.002.

Figure 9: ODB Data for GPRS services

```

└Roaming Restriction Due To Unsupported Feature
  
```

NOTE: For detailed information see 3GPP TS 29.002.

Figure 10: Roaming Restriction Data in the VLR

```

└Roaming Restricted in the SGSN Due To Unsupported Feature
  
```

NOTE: For detailed information see 3GPP TS 29.002.

Figure 11: Roaming Restriction Data in the SGSN

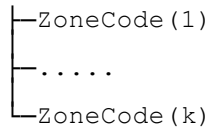

NOTE: For detailed information see 3GPP TS 29.002.

Figure 12: Regional Subscription Data

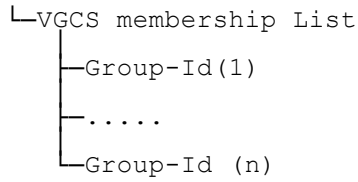

NOTE: For detailed information see 3GPP TS 43.068 and 3GPP TS 29.002.

Figure 13: Voice Group Call Data

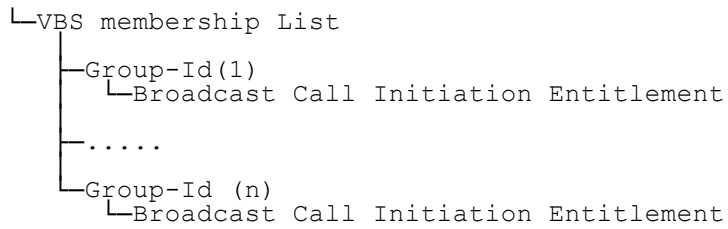

NOTE: For detailed information see 3GPP TS 43.069 and 3GPP TS 29.002.

Figure 14: Voice Broadcast Call Data

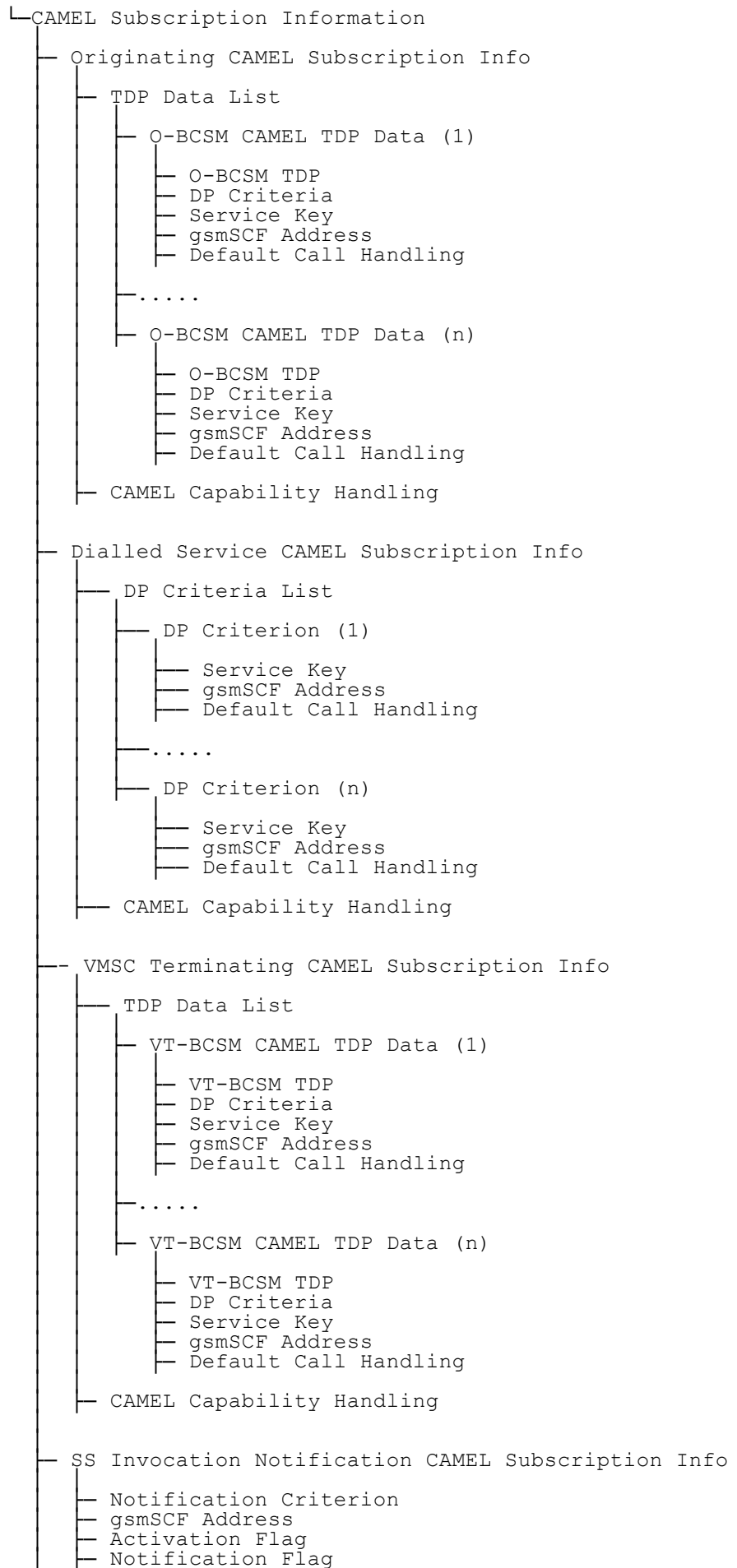

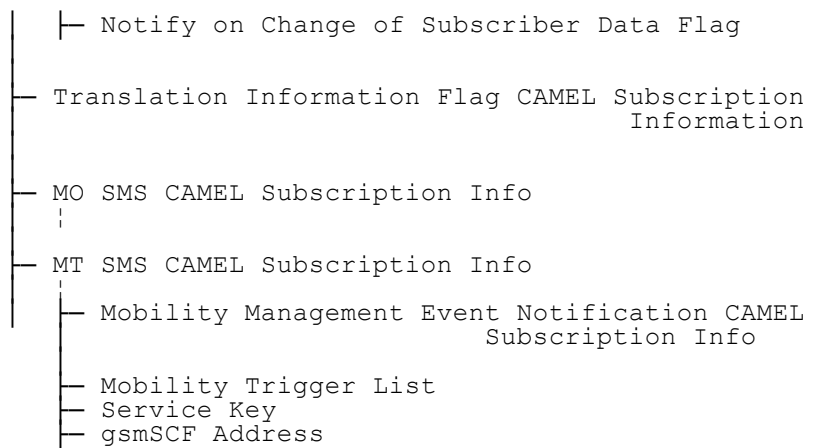

NOTE: For detailed information see 3GPP TS 23.072, 3GPP TS 23.078 and 3GPP TS 29.002.

Figure 15: CAMEL subscription info

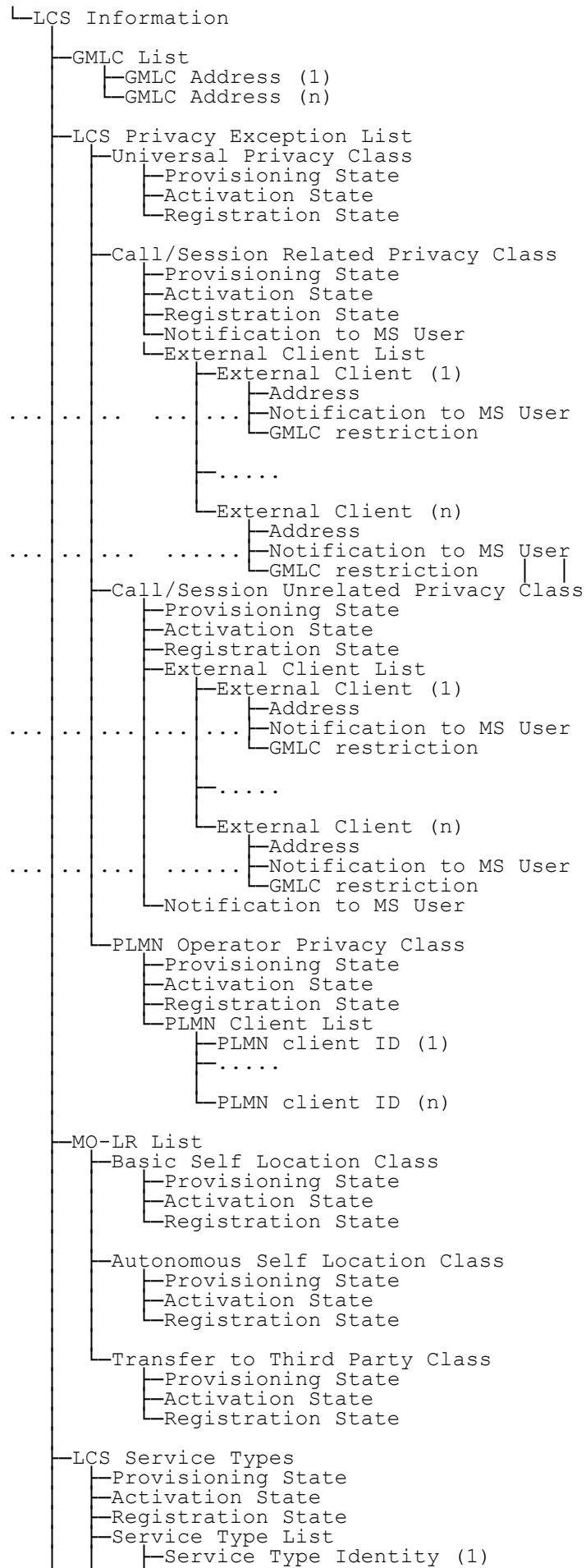

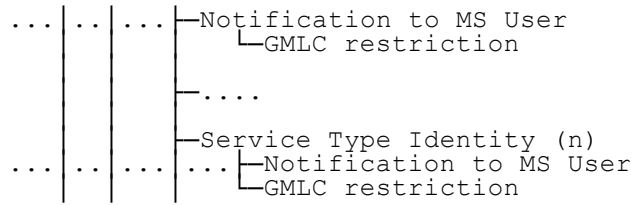

NOTE: For detailed information see 3GPP TS 23.271 and 3GPP TS 29.002.

Figure 16: LCS Information

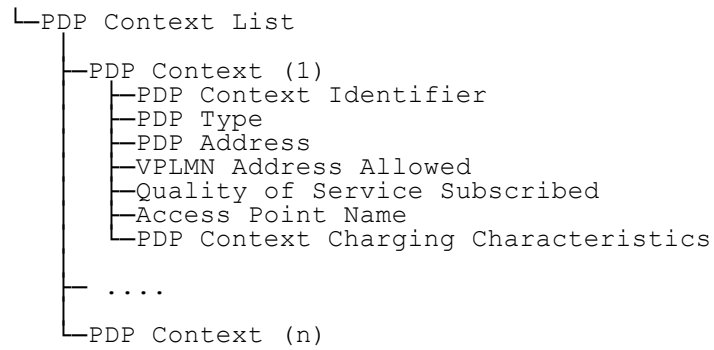

NOTE: The figure shows the information in the SGSN. For detailed information see 3GPP TS 23.060. For information about the GGSN information, see 3GPP TS 23.008.

Figure 17: GPRS subscription data

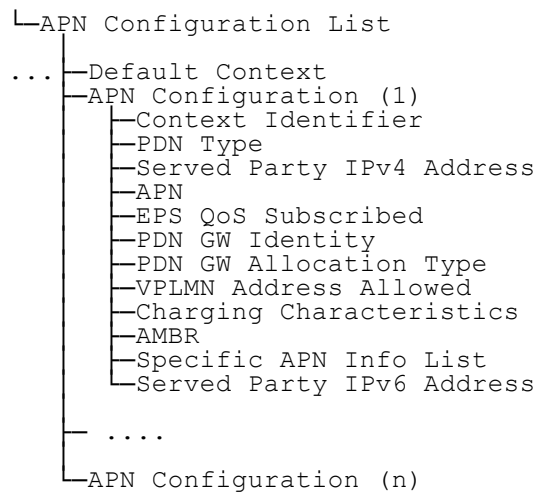
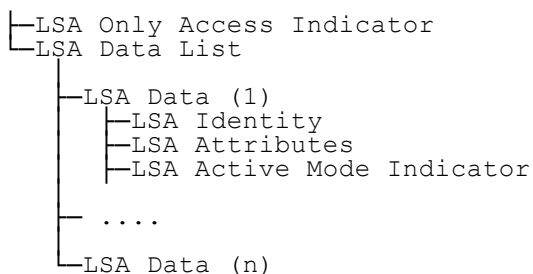
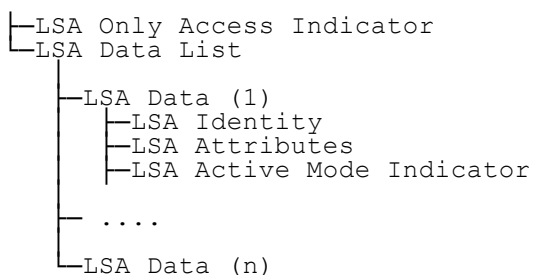

Figure 17a: EPS subscription data



NOTE: For detailed information see 3GPP TS 23.073 and 3GPP TS 29.002.

Figure 18: LSA data in the VLR



NOTE: For detailed information see 3GPP TS 23.073 and 3GPP TS 29.002.

Figure 19: LSA data in the SGSN



NOTE: For detailed information see 3GPP TS 43.035 and 3GPP TS 29.002.

Figure 20: IST data in the VLR

└Age Indicator

NOTE: For detailed information see TS 23.116 and TS 29.002.

Figure 21: Super-Charger Information

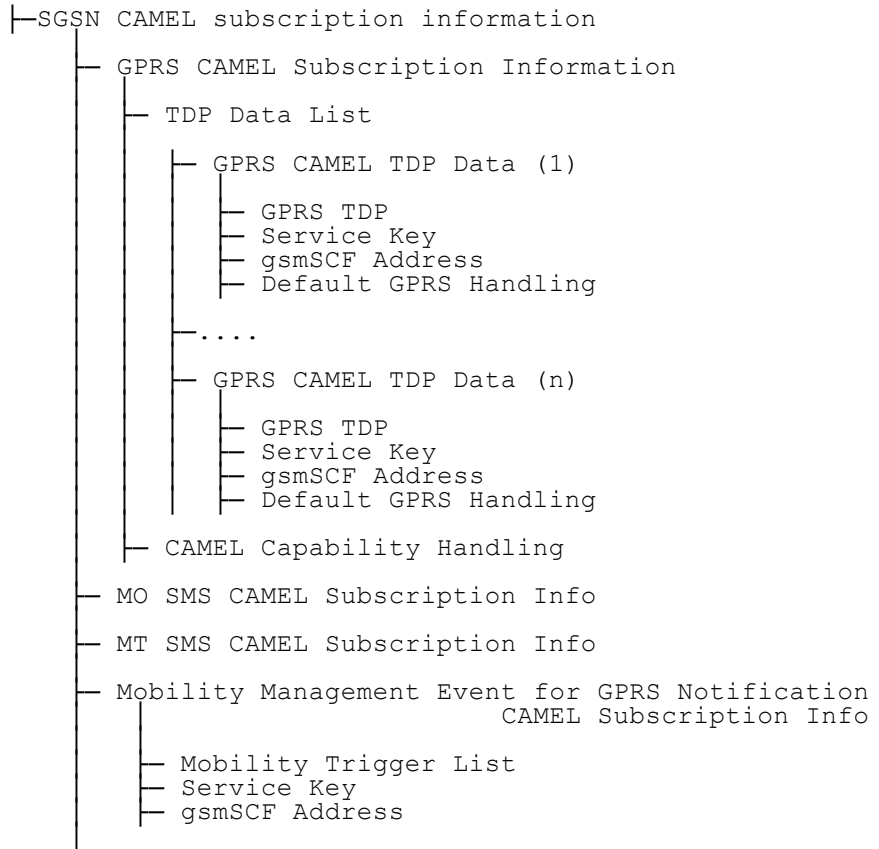

Figure 22: SGSN CAMEL subscription info

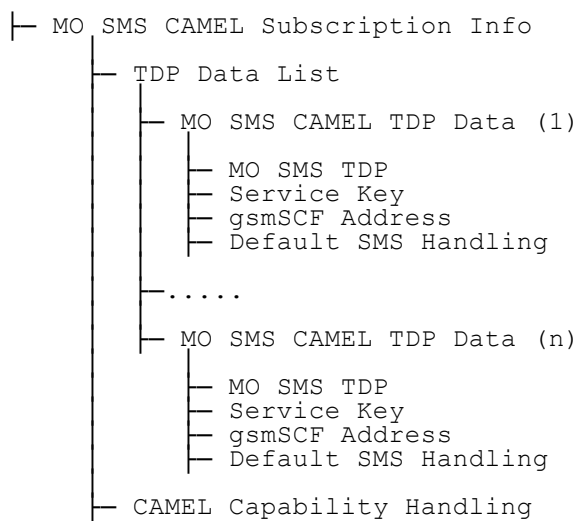

Figure 23a: MO SMS CAMEL Subscription Info

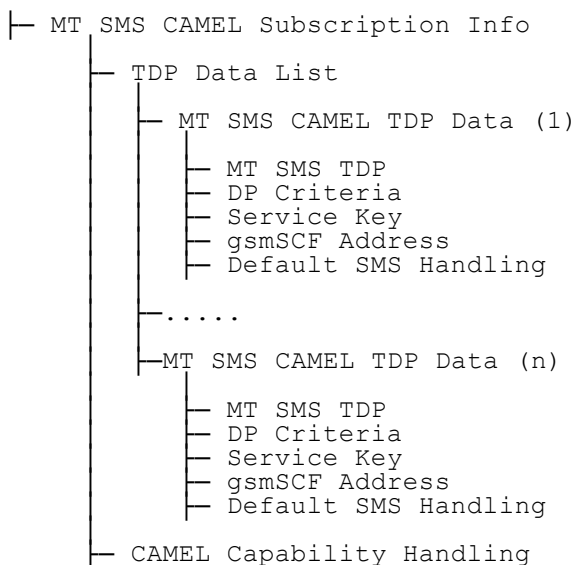

Figure 23b: MT SMS CAMEL Subscription Info

└CS Allocation/Retention priority

NOTE: For detailed information see 3GPP TS 23.008.

Figure 24: Bearer Service Priority Data in the VLR

└Subscribed Charging Characteristics

NOTE: For detailed information see 3GPP TS 23.060.

Figure 25: Charging Information.

└Access Restriction Data

NOTE: For detailed information see 3GPP TS 23.012 [34].

Figure 26: Administrative Restriction Information in the VLR

Annex A (informative): Change history

Change history						
TSG CN#	Spec	Version	CR	<Phase>	New Version	Subject/Comment
Apr 1999	GSM 03.16	7.0.0				Transferred to 3GPP CN1
CN#03	23.016				3.0.0	Approved at CN#03
CN#04	23.016	3.0.0	001	R99	3.1.0	Introduction of TIF-CSI for Call Deflection
CN#04	23.016		002r1	R99	3.1.0	Missing SS-CSI in description of CAMEL Subscription
CN#05	23.016	3.1.0	003r1	R99	3.2.0	Non-CAMEL IST implementation
CN#06	23.016	3.2.1	004r3	R99	3.3.0	Introduction of the Super-Charger Concept in TS 23.016
CN#06	23.016	3.2.1	006	R99	3.3.0	Support of Subscriber Data Management in the HLR and VLR for LCS
CN#06	23.016	3.2.1	009	R99	3.3.0	Correction of VLR subscription Data
CN#06	23.016	3.2.1	008r1	R99	3.3.0	Introduction of CAMEL phase 3
CN#07	23.016	3.3.0	010	R99	3.4.0	Correction of LSA Information
CN#07	23.016	3.3.0	011r1	R99	3.4.0	The addition of priority information
CN#07	23.016	3.3.0	012r2	R99	3.4.0	Introduction of subscriber data for Multicall
CN#08	23.016	3.4.0	013r1	R99	3.5.0	Addition of information related to charging
CN#08	23.016	3.4.0	014	R99	3.5.0	Clarifications on GSM vs. UMTS specific parts
CN#08	23.016	3.4.0	015	R99	3.5.0	Addition of charging characteristics per PDP context
CN#09	23.016	3.5.0	016	R99	3.6.0	Correction to Delete Subscriber Data
CN#11	23.016	3.6.0	018	R99	3.7.0	Alignment about Notification to MS User between 29.002 , 23.171(LCS Stage2) and 23.016
CN#11	23.016	3.7.0		Rel-4	4.0.0	Version increased from R99 to Rel-4 after CN#11
CN#11	23.016	3.7.0	017r1	Rel-4	4.0.0	Add three subscriber statuses to the ODB Data for GPRS services
CN#11	23.016	3.7.0	019r2	Rel-4	4.0.0	Extension of call related privacy class for LCS Release 4
CN#11	23.016	3.7.0	020r1	Rel-4	4.0.0	PS domain support for LCS Release 4
CN#15	23.016	4.0.0	023r2	Rel-4	4.1.0	Clarification on overlapping data
CN#15	23.016	4.0.0		Rel-4	4.1.0	References updated
CN#15	23.016	4.1.0	021	Rel-5	5.0.0	Collective CR on 23.016
CN#16	23.016	5.0.0	025	Rel-5	5.1.0	Clarification of introducing Session related and unrelated class
CN#16	23.016	5.0.0	026	Rel-5	5.1.0	LCS: Codeword and Service Type
CN#17	23.016	5.1.0	029	Rel-5	5.2.0	Introduction of Call Deflection
CN#19	23.016	5.2.0	030r1	Rel-6	6.0.0	Introduction of Call Barring for SMS in PS domain
CN#23	23.016	6.0.0	034r2	Rel-6	6.1.0	Correction to SS data for LCS SS
CN#23	23.016	6.0.0	035r1	Rel-6	6.1.0	Include administrative restriction subscription parameter
CT#36	23.016	6.1.0		Rel-7	7.0.0	Upgraded unchanged from Rel-6
CT#42	23.016	7.0.0		Rel-8	8.0.0	Upgraded unchanged from Rel-7
CT#46	23.016	8.0.0	-	Rel-9	9.0.0	Update to Rel-9 version (MCC)
CT#47	23.016	9.0.0	0037	Rel-9	9.1.0	Addition of EPS Subscription Information
2011-03	23.016	9.1.0	-	Rel-10	10.0.0	Update to Rel-10 version (MCC)
2012-09	23.016	10.0.0	-	Rel-11	11.0.0	Update to Rel-11 version (MCC)