

3G TR 22.945 V3.0.0 (1999-10)

Technical Report

3rd Generation Partnership Project; Technical Specification Group Terminals; Study on provisioning of fax in GSM and UMTS (3G TR 22.945 version 3.0.0)



The present document has been developed within the 3rd Generation Partnership Project (3GPP™) and may be further elaborated for the purposes of 3GPP.

The present document has not been subject to any approval process by the 3GPP Organisational Partners and shall not be implemented.

This Specification is provided for future development work within 3GPP only. The Organisational Partners accept no liability for any use of this Specification.

Specifications and reports for implementation of the 3GPP™ system should be obtained via the 3GPP Organisational Partners' Publications Offices.

Reference

DTR/TSGT-0222945U

Keywords

R99 Report 3G

3GPP

Postal address

3GPP support office address

650 Route des Lucioles - Sophia Antipolis
Valbonne - FRANCE
Tel.: +33 4 92 94 42 00 Fax: +33 4 93 65 47 16

Internet

<http://www.3gpp.org>

Copyright Notification

No part may be reproduced except as authorized by written permission.
The copyright and the foregoing restriction extend to reproduction in all media.

© 1999, 3GPP Organizational Partners (ARIB, CWTS, ETSI, T1, TTA, TTC).
All rights reserved.

Contents

Foreword	4
Introduction	5
1 Scope	6
2 References	6
3 Abbreviations	7
4 Requirements	7
5 Business Model	8
6 Store and Forward Facsimile (T.37)	8
6.1 Description	8
6.2 Application in UMTS and GSM	9
6.2.1 Architecture	9
6.2.2 Mobile Originated	10
6.2.3 Mobile Terminated	11
6.2.4 Handover Procedures	11
6.2.5 Roaming	12
7 Real Time Facsimile (T.38)	12
7.1 Description	12
7.2 Application in UMTS and GSM	12
7.2.1 Architecture	12
7.2.2 Mobile Originated	13
7.2.3 Mobile Terminated	14
7.2.4 Handover Procedures	14
7.2.5 Roaming	14
8 Integration of Services	14
8.1 Combining T.37 and T.38 based solutions	15
8.2 Combining Facsimile with a Short Message Service, SMS	15
8.3 Combining Facsimile with Mailbox-Service	16
8.4 Combining Facsimile with WWW or WAP	16
8.5 Combining Facsimile and HLR functionality	17
8.6 Integrating Facsimile within a Multimedia Message Service, MMS	17
History	19

Foreword

This Technical Report has been produced by the 3GPP.

The contents of the present document are subject to continuing work within the TSG and may change following formal TSG approval. Should the TSG modify the contents of this TS, it will be re-released by the TSG with an identifying change of release date and an increase in version number as follows:

Version x.y.z

where:

- x the first digit:
 - 1 presented to TSG for information;
 - 2 presented to TSG for approval;
 - 3 Indicates TSG approved document under change control.
- y the second digit is incremented for all changes of substance, i.e. technical enhancements, corrections, updates, etc.
- z the third digit is incremented when editorial only changes have been incorporated in the specification;

Introduction

Currently in GSM, there are two facsimile services specified: teleservice TS61 "Alternate speech/facsimile G3" and TS62 "Automatic facsimile G3". These two services utilise the T.30 [2] protocol between the mobile station and the facsimile machine at the other end. Both services exist in two modes, transparent (acc. GSM TS 03.45) and non-transparent (acc. GSM TS 03.46). Although the transparent mode is designed to be transparent to the network, intervention of the IWF is needed whenever this service is used. The reasons for this are explained in GSM TS 03.45 [6] and are briefly summarised below:

- The GSM speech bearers are not adequate for transporting the modulated information transmitted between the fax machines. A data bearer must be set up between the IWF and the MS and the IWF must convert the modem signals to digital form as for all modem services.
- Not all messages defined in the T.30 protocol are applicable in the mobile case. The IWF must filter the messages sent from the facsimile machine in the fixed network.
- Fall back messages require that a different rate adaptation is applied on the mobile leg or that a different channel is used

High failure rates depending on the equipment used are often experienced. This is mainly due to the high error rates on the radio interface and to long transmission delays. Different manufacturers have implemented various procedures to handle these problems, but due to the large variety of facsimile machines used in the fixed network and their various implementations of the T.30 protocol, it is not possible to guarantee acceptable performance. The cost experienced by manufacturers for development, trouble shooting and maintenance related to the facsimile services is high. Alternative ways of transmitting facsimile messages to and from mobile users need to be investigated.

In contrast to the quality provided by the transparent mode, the quality provided by non-transparent mode is much better provided that the bit error rate is low. However, for bit error rates exceeding a certain threshold it is not possible at all to transmit a facsimile document and the transmission results in the following behaviour. The sending Fax equipment expects the acknowledgement on the partial page within a certain time frame. The RLP entity of the receiver delivers the first part of a T.30 partial page without any error to the receiving Fax equipment. Due to the RLP retransmissions the receiving Fax equipment is not able to send the acknowledgement in time. Therefore the sending Fax equipment aborts the transmission of the document.

The aim of this report is to show that alternative solutions exist. Given that most of the problems experienced today can be traced to the termination of the T.30 in the mobile station, the alternative solutions described in this report, which have initially been developed for usage in the Internet, will all be based on terminating the T.30 protocol in the network and using some alternative transmission method to and from the mobile user.

In addition to the development problems listed above, one may argue that the GSM facsimile services TS61 and TS62 are not appropriate. Mobile terminated facsimile calls are rare, because the mobile user equipment is seldom ready to accept such calls. Also, most user equipment do not allow the user to switch between speech and facsimile mode, which implies that the alternate facsimile/speech service is almost not used. This argument applies to both modes of transmission, transparent and non-transparent.

This report studies the applicability of two particular protocols: T.37 [3] and T.38 [4] which in turn are based on many IETF RFCs. It does not intend to express any preference for one or the other as both can be applied. They may be integrated either together or separately with already established GSM/Internet specific services.

Although this report is the result of a UMTS work item, it is intended to be applied to GSM as well, thereby increasing the interoperability between UMTS and GSM networks.

1 Scope

This document gives guidance on how facsimile services can be provided in a GSM or UMTS network. It studies how facsimile messages can be exchanged between mobile equipment and a PSTN facsimile machine. Although the approaches described herein can be applied to cases where none of the end points are connected to a PSTN, the study of such cases are out of the scope of this document.

The Scope shall not contain requirements.

2 References

The following documents contain provisions which, through reference in this text, constitute provisions of the present document.

- References are either specific (identified by date of publication, edition number, version number, etc.) or non-specific.
- For a specific reference, subsequent revisions do not apply.
- For a non-specific reference, subsequent revisions do apply.
- A non-specific reference to an ETS shall also be taken to refer to later versions published as an EN with the same number.

- [1] ITU-T Recommendation F.185: "Internet Facsimile: Guidelines for the support of the communication of Facsimile Documents"
- [2] ITU-T Recommendation T.30: "Procedures for document facsimile transmission in the general switched telephone network"
- [3] ITU-T Draft New Recommendation T.37: "Procedures for the transfer of facsimile data via store and forward on the internet"
- [4] ITU-T Draft New Recommendation T.38: "Procedures for real time group 3 facsimile communication between terminals using IP networks"
- [5] ITU-T Recommendation H.323: "Visual telephone systems and equipment for local area networks which provide a non-guaranteed quality of service"
- [6] GSM Technical Specification 03.45: "Technical realization of facsimile group 3 transparent "
- [7] UMTS 21.04: UMTS; Requirements for the support of data services in UMTS
- [8] UMTS 22.00: UMTS; UMTS Phase 1
- [9] draft-ietf-fax-goals-04.txt, available at <http://www.ietf.org/>
- [10] draft-ietf-fax-eifax-12.txt, available at <http://www.ietf.org/>
- [11] Wireless Application Protocol (WAP) version 1.0, available at <http://www.wapforum.org>
- [12] GSM Technical Specification 03.46: "Technical realization of facsimile group 3 non-transparent"

For the benefit of the reader, a large number of IETF Requests for Comments and drafts could be listed here. However, they are all referenced in the documents listed in this reference list.

3 Abbreviations

For the purposes of the present document, the following abbreviations apply:

BSS	Base Station System
e-mail	electronic mail
Fax	Facsimile
GGSN	Gateway GPRS Support Node
G-MSC	Gateway MSC
GPRS	General Packet radio Service
GR	GPRS Register
GSM	Global System for Mobile Communication
HLR	Home Location Register
HTML	Hyper Text Markup Language
IETF	Internet Engineering Task Force
IMAP4	Internet Message Access Protocol, version 4
IP	Internet Protocol
ISDN	Integrated Services Digital Network
ISP	Internet Service Provider
ITU	International Telecommunication Union
IWF	Interworking Function
MM	Multimedia Messaging
MMS	Multimedia Messaging Service
MS	Mobile Station
MSC	Mobile Switching Centre
PC	Personal Computer
PDF	Portable Document Format
PLMN	Public Land Mobile Network
POP3	Post Office Protocol, version 3
PPP	Point-to-point Protocol
PSTN	Public Switched Telephone Network
RFC	Request for Comments
SGSN	Serving GPRS Support Node
SMS	Short Message Service
SMTP	Simple Message Transfer Protocol
TIFF	Tag Image File Format
TS 61	Teleservice 61
TS 62	Teleservice 62
UE	User Equipment
UMTS	Universal Mobile Telecommunications System
USSD	Unstructured Supplementary Service Data
UTRAN	UMTS Terrestrial Radio Access Network
VLR	Visitor Location Register
WAP	Wireless Application Protocol
WML	Wireless Markup Language
WWW	World Wide Web

4 Requirements

Since this report is not a specification, the requirements listed in this section are provided as guidance to evaluate facsimile services.

The reader is referred to the documents below for a rather complete list of requirements

- ITU-T F.185 [1]

- draft-ietf-fax-goals-04.txt [9]
- draft-ietf-fax-eifax-12.txt [10]

Also requirements in UMTS 21.04 [7] and 22.00 [8] are applicable.

The following requirements apply specifically to mobile networks:

- No or minor implementation impacts on GSM and UMTS
- Handover between and within GSM and UMTS shall be possible during the downloading to and uploading from the mobile equipment of a facsimile message.
- Exchange of facsimile messages shall be possible when roaming to other networks.
- The access network shall be transparent to the users of the facsimile service, meaning, for instance, that a user may choose to download a message to a PC attached to a fixed network or to mobile equipment.

5 Business Model

At least three entities may be distinguished that are involved in the provision of the facsimile services described in this document. First, the PLMN operator provides the access from a mobile user to the IP network. Second the Internet Service Provider (ISP) provides IP network access. Third, the Facsimile service provider provides the service as an application running on the PLMN and IP network. (The PSTN operator, could be added to this list, but there is no direct relationship between the mobile user and the PSTN operator, so this entity is left out here.) One entity may play more than one provider role, for instance, the PLMN operator may also be the ISP or service provider for an integrated implementation. However, the purpose of distinguishing the providers here is to better describe which contribution from each of them is needed for the total provision of the facsimile services. The aim is to show that the facsimile services may be provided without any specific contribution from the PLMN operator and the ISP. Only if the facsimile service is integrated with other services such as SMS or within an MMS, as described in more detail in Section 8, will there be demands on the PLMN.

Since there are several providers involved in the provision of the service, several subscription checks may be needed.

6 Store and Forward Facsimile (T.37)

6.1 Description

T.37 defines procedures that enable facsimile data to be transferred using Internet e-mail as a store-and-forward system. Approved IETF protocols are used for posting, relaying and delivery of documents. This approach does not require any changes to existing Internet standards or ITU-T recommendations. The model is shown in Figure 1.

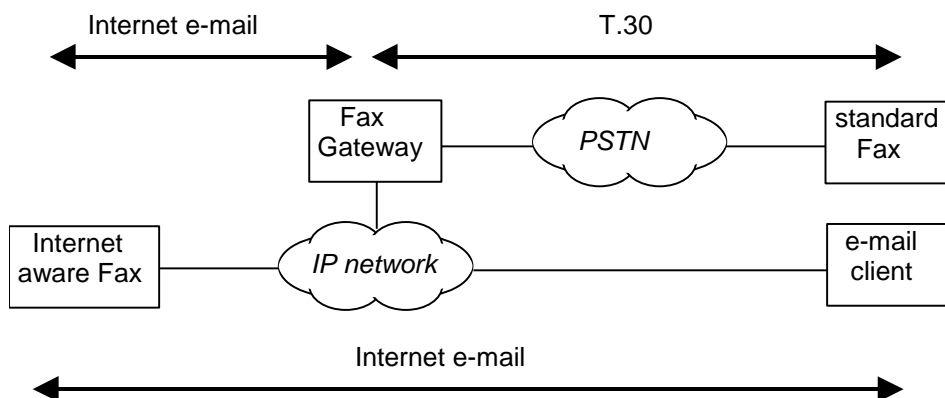

Figure 1: Store-and-forward fax according to T.37

The gateway (in the IETF RFCs referred to as offramp / onramp gateway) terminates the T.30 facsimile protocol towards the PSTN. Fax data will be attached to e-mail messages as fax images and forwarded via Internet e-mail. A standard fax device is only capable of supporting T.30. An Internet aware fax combines the capabilities of a standard fax device and an e-mail client.

Two modes of operation are specified.

- The Simple Mode supports only the transfer of image data.
- In addition to that the Full Mode requires the exchange of capabilities and the confirmation of receipt. This is to emulate the end-to-end nature of fax between sender and receiver known from fixed network fax.

6.2 Application in UMTS and GSM

6.2.1 Architecture

The application of a T.37 based solution in UMTS and GSM requires the installation of gateways that terminate the T.30 protocol toward the PSTN and that connect the PSTN with the Internet. Since T.37 uses Internet e-mail (e.g. SMTP) in order to transport fax images attached to e-mail messages, there are no further requirements to the PLMN for the information transport.

The mobile station needs in addition to Internet access only a TIFF image viewer.

T.37 provides rather a message-based service than a real-time facsimile service according to T.30 or T.38, respectively. Whereas the T.37 Simple Mode provides only an e-mail interface, the Full Mode is able to provide a facsimile service with all of the functions known from the fixed network, e.g. the confirmation of receipt.

With the application of T.37 in a PLMN it is possible to provide at the mobile station an unique communication interface for a lot of services, e.g. electronic messaging, facsimile, voice over IP. Also for network operators it is of advantage because they are able to provide these services with an integrated server (refer to Section 8).

A general approach of the application of a T.37 based solution is shown in Figure 2.

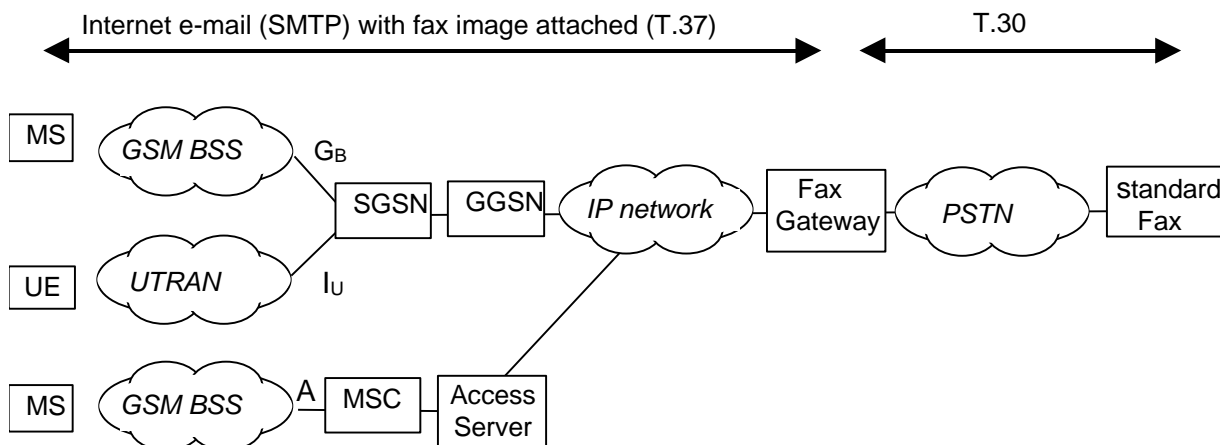

Figure 2: General approach for the application of T.37 for the provision of facsimile service in UMTS and GSM

In Figure 2 a call is routed directly from the PSTN to the gateway. It is more reasonable to route mobile terminated calls via the G-MSC of the PLMN. By doing this

- the multi-numbering scheme of GSM could be used for identifying fax calls from the PSTN;
- supplementary services could be provided (e.g. call forwarding);
- network operator could use already installed fax-mailboxes;

These services and functions are described more in detail in Section 8.

6.2.2 Mobile Originated

A mobile originated facsimile call looks like a set-up of an IP Bearer by the mobile station. The application “facsimile” is transparent for GSM or UMTS, respectively. The particular handling depends on the used products for e-mail and Fax Gateway. It could be as follows:

The user starts his e-mail application, writes an e-mail and sends it to the Fax Gateway. For this the e-mail programme could set-up a connection (e.g. POP3 or IMAP4) to the e-mail server based on the IP Bearer provided by GSM or UMTS, respectively. The written e-mail provided with the designated receiver’s fax number is then sent to the e-mail address of the Fax-Gateway.

Depending on the functions of the Fax Gateway the e-mail may contain only plain text or also attachments. Although T.37 requires only a TIFF format according to RFC 2301 Profile S there are Fax Gateways that support a lot of different formats for included attachments (e.g. formats of particular office programmes and other file formats like HTML, TIFF, GIF, PDF, ...).

Fax Gateways expect the designated receiver’s fax number very differently. Some products expect the fax number as part of their own e-mail address (e.g. remote-printer.info@<fax_number>.idd.tpc.int). Other products provide own clients that give the user the possibility to provide the fax number in a separate entry. Those functions are already included in some PC operation systems. Again other products expect the fax number in an existing field of the e-mail header (e.g. the subject or alternative recipient field).

The Fax Gateway converts the received e-mail into a facsimile document and sends it via the PSTN/ISDN to the designated receiver’s fax number. Notifications may be sent back to the e-mail sender.

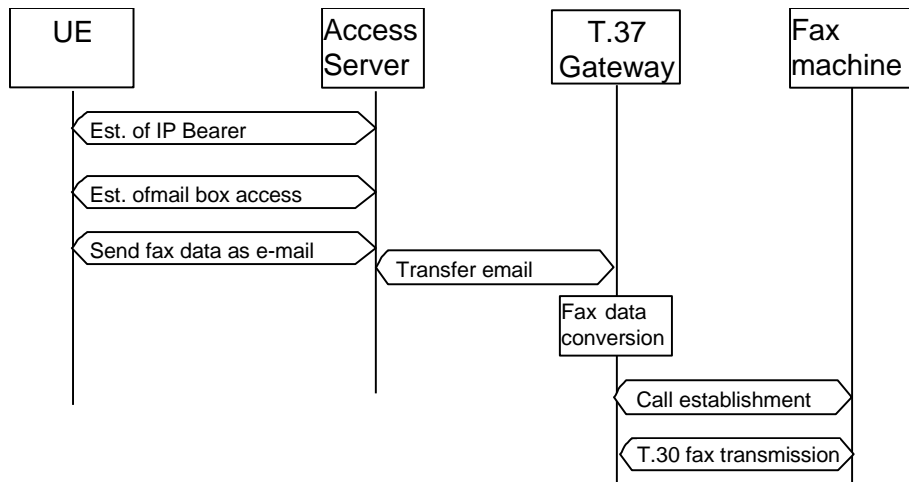

Figure 3: Transmission of store-and-forward fax, MO

6.2.3 Mobile Terminated

Mobile terminated facsimile calls may be routed either directly to the Fax Gateway or via the G-MSC to the Fax Gateway. Routing via the G-MSC enables the use of the multi-numbering scheme to identify the call as a facsimile call and of the supplementary services for such calls (e.g. call forwarding).

The Fax Gateway converts the received facsimile document into an e-mail. It also translates the receiver’s fax number into the receiver’s e-mail address. The e-mail is forwarded to the e-mail server. The e-mail is stored in the receiver’s mailbox. The receiver may be informed via the Short Message Service (SMS).

The e-mail with the facsimile document will only be delivered on request by the receiver. The user starts his e-mail application. The e-mail programme could set-up a connection (e.g. POP3 or IMAP4) to the e-mail server based on the IP Bearer provided by GSM or UMTS, respectively. A list of received e-mails is provided to the user. The user can retrieve or forward e-mails.

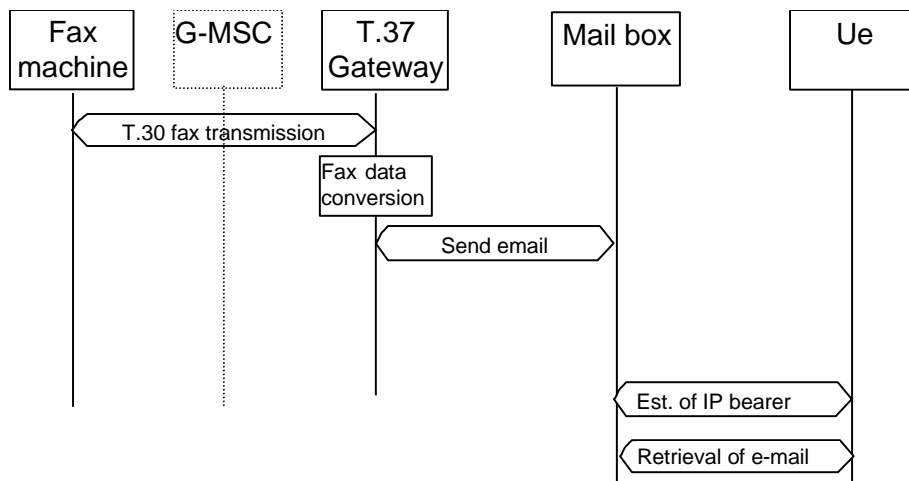

Figure 4: Transmission of store-and-forward fax, MT

6.2.4 Handover Procedures

The same Fax Gateway is serving the call before and after the handover, which implies that no special procedures are needed for the support of handover.

6.2.5 Roaming

IP access while roaming is already covered by standard procedures.

7 Real Time Facsimile (T.38)

7.1 Description

T.38 [4] is a protocol used to transfer Group 3 facsimile messages in real time over IP networks. It specifies the messages and data exchanged between facsimile gateways connected via an IP network. The reference model for this Recommendation is shown in Figure 5.

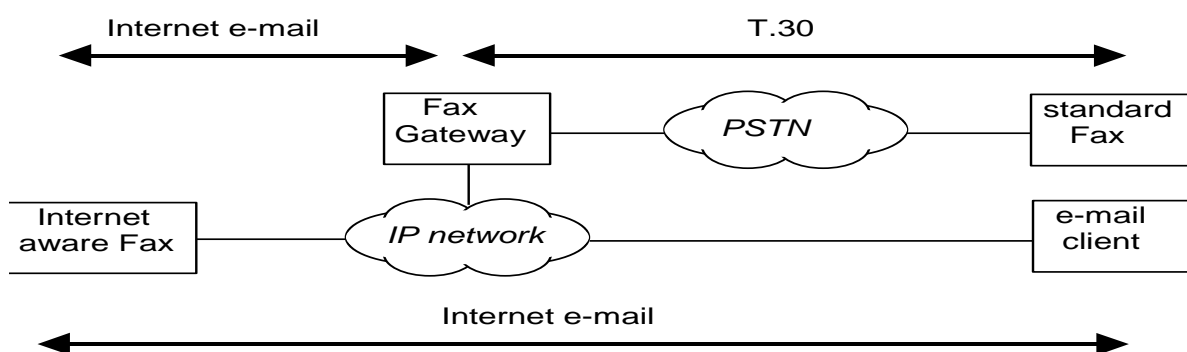

Figure 5: T.38 reference model

The T.38 protocol is applied between the two gateways, between a gateway and an internet aware fax device, or two internet aware fax devices. The communication between the gateways and the G3 facsimile terminals is according to T.30. The call establishment procedures are based on H.323, Annex D [5] and are specified in Annex B of Recommendation T.38.

In order to apply T.38 to GSM or UMTS, the mobile equipment shall have to play the role of an internet aware fax device. Only one gateway would be required, placed between the IP network and the PSTN/ISDN. This gateway could be provided by the PLMN operator or by an independent service provider.

When applying it to GSM or UMTS, T.38 could also be provided together with T.37 and other messaging services. T.37 could be used as a fall-back service if, for instance, the transmission delay between the fax gateway and the mobile equipment causes problems for the T.38 protocol. T.38 could also be limited to sending fax messages from the mobile, using T.37 for the mobile terminated facsimile transmissions.

See Section 8 for more details.

7.2 Application in UMTS and GSM

7.2.1 Architecture

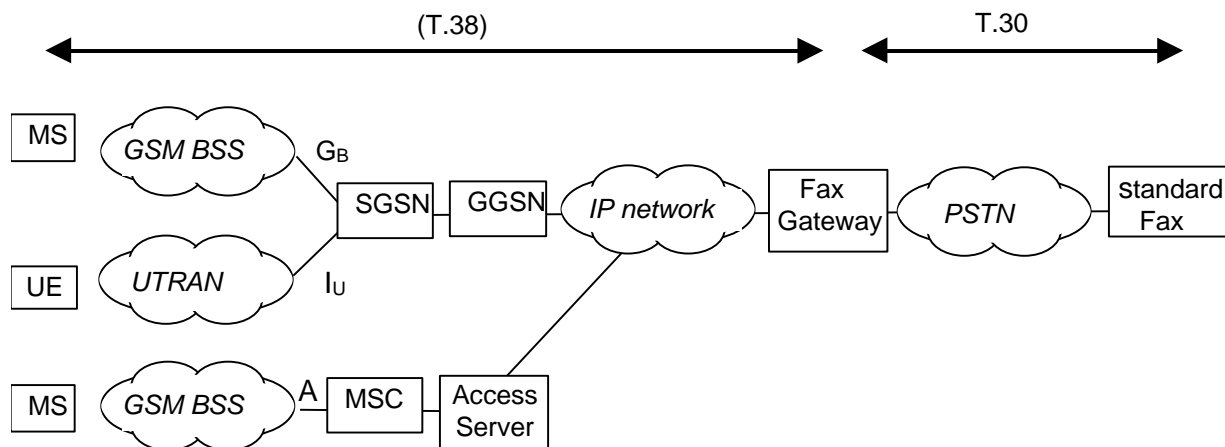

Figure 6: General approach for the application of T.38 for the provision of facsimile service in UMTS and GSM

Figure 6 shows the physical architecture. The T.38 reference model is applied such that the User Equipment is an Internet aware fax terminal. The PLMN provides access to the IP network. A Gatekeeper may be used in the call setup. The mobile equipment (MS/UE) is connected to the IP network either by a PPP connection on a circuit switched bearer to an Internet Service Provider (ISP) or via a packet switched connection. The T.38 protocol is terminated in the mobile equipment. The mobile equipment must therefore have T.38 client software installed and must allow the use of data services required to access the IP network.

Note that, alternatively, the mobile equipment could be split into a network termination playing the role of a T.38 fax gateway and a facsimile machine attached to it by a T.30/PSTN interface. This configuration would be applicable to the case where the network termination is permanently attached to the IP network providing a (fixed) radio access to the facsimile machine.

7.2.2 Mobile Originated

Figure 7 illustrates the call setup procedure in a mobile originated facsimile call. First a data bearer is set up between the User Equipment and the IP access server or, alternatively, the IP network is accessed via the GGSN. The T.38 Annex B procedures are used to set up a connection to the receiving fax machine via the T.38 gateway. The facsimile message is transmitted using the T.38 protocol between the UE and the fax gateway, and the T.30 protocol is used between the gateway and the receiving fax machine. There are different ways the calling entity can convey the address of the called entity to the T.38 gateway, such as using prompt or double dialling.

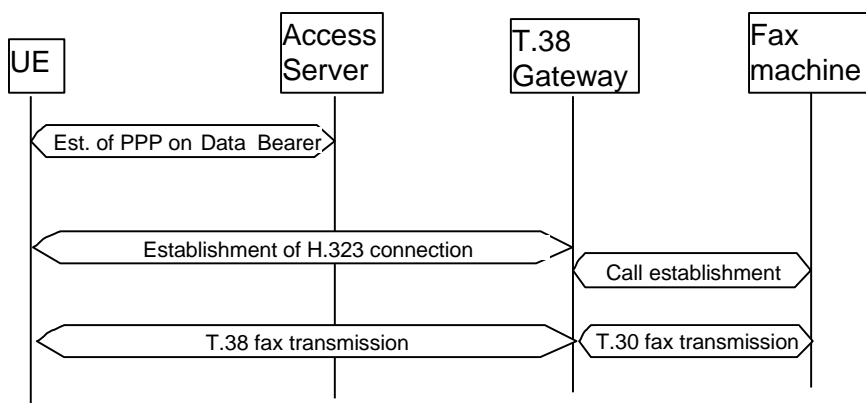

Figure 7: Transmission of real time fax, MO

7.2.3 Mobile Terminated

Sending facsimile messages to a mobile depends on the possibility to address a mobile from an IP network. Currently that is not possible using a circuit switched connection to the mobile. For mobile terminated facsimile calls it may be better to use the T.37 protocol. That protocol has also the advantage that it lets the mobile user prepare the equipment for receiving a facsimile message, e.g., connect the terminal to the phone.

In certain cases, e.g., when the mobile equipment is permanently attached to the IP network, T.38 can be applied in the mobile terminated case as well. The call establishment procedure is as specified in T.38, Annex B.

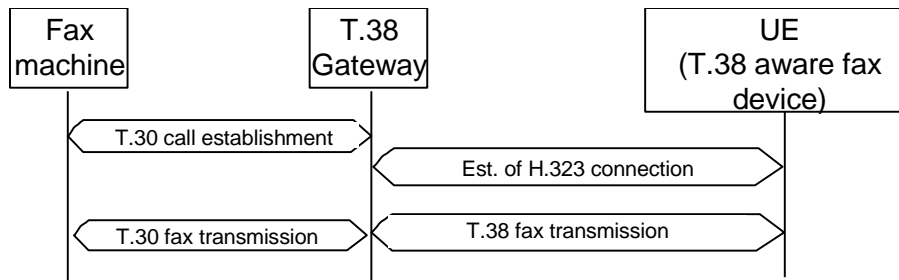

Figure 8: Transmission of real time fax, MT

7.2.4 Handover Procedures

The same fax gateway is serving the call before and after the handover, which implies that no special procedures are needed for the support of handovers. The T.38 protocol may be sensitive to the loss of data and additional delay associated with a handover.

7.2.5 Roaming

IP access while roaming is already covered by standard procedures.

8 Integration of Services

This section highlights the benefits which can be achieved by combining the aforementioned principles together with GSM and Internet specific services. It focuses on re-using already installed techniques and furthermore proposes a generic mechanism to provide a uniform interface across different services for the user.

Figure 9 gives an insight into the overall architecture for integrating T.37 / T.38 together with already established services.

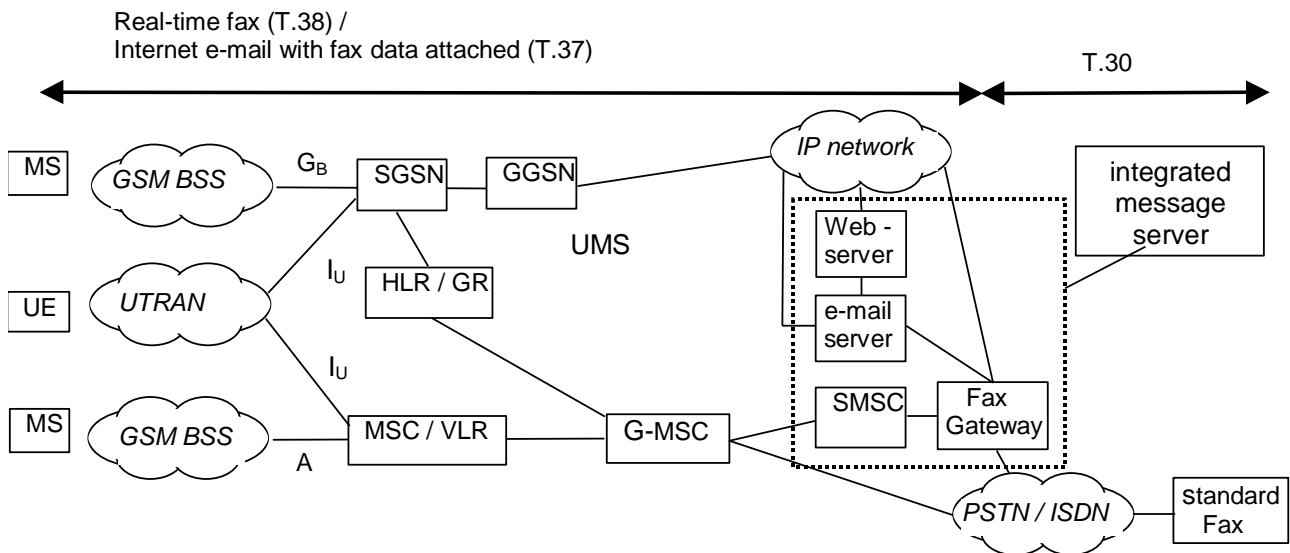

Figure 9: The application of T.37/T.38 for the provision of facsimile service in UMTS and GSM

8.1 Combining T.37 and T.38 based solutions

Depending either on the user's, network operator's or service provider's view, the T.38 protocol is preferred if a facsimile receiver is permanently available, due to its real-time aspects (reliability of successful delivery). However, if the facsimile receiver is not always ready to receive facsimile data, a combination of the T.37 together with the T.38 is useful. This could mainly be the case for mobile terminated facsimile calls, because a T.38 mobile device is not necessarily or permanently available. Then the Fax gateway should use the T.37 protocol. Another scenario is to use T.37 as a fall back solution if a successful T.38 transmission is not guaranteed or not possible, as for example due to (T.30) timing problems or if a T.38 device is temporarily not available.

8.2 Combining Facsimile with a Short Message Service, SMS

In the context of a store-and-forward facsimile service, the GSM-SMS can be used as an appropriate notification and acknowledgement mechanism to inform either the receiver or the sender in the mobile terminated or originated case respectively, about current delivery status. Figure 10 visualises a possible scenario. For the mobile originated case the SMS could acknowledge both the storage and the forwarding status, whereas for the mobile terminating case only the notification of a new message arrival is needed.

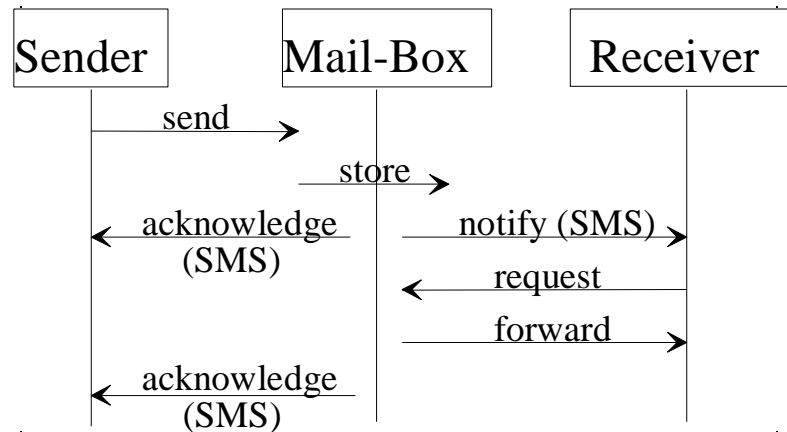

Figure 10: Example on how acknowledgement and notification could be established

8.3 Combining Facsimile with Mailbox-Service

The combination of the T.37 protocol together with the common e-mail service provides the advantage of only one mailbox and thus the same handling. This implies, for example, a unique user interface, only one user identification and a unique administration.

8.4 Combining Facsimile with WWW or WAP

The combination of facsimile together within a WWW service relates mainly to mailbox control functions and an alternative down- and uploading mechanism. It is not necessarily T.37 based. In this combination the user can access a Web-page providing functions like:-

- redirection of incoming Faxes to Fax machines
- writing and sending Faxes
- maintaining the mailbox
- administration of user profiles

Considering the access with a WAP browser via a WAP server, the HTML is converted into WML and thus the restricted capabilities (e.g. screen size) of an MS are met. A further advantage is that WAP does not necessarily need an IP connection. Alternative bearers are e.g. USSD.

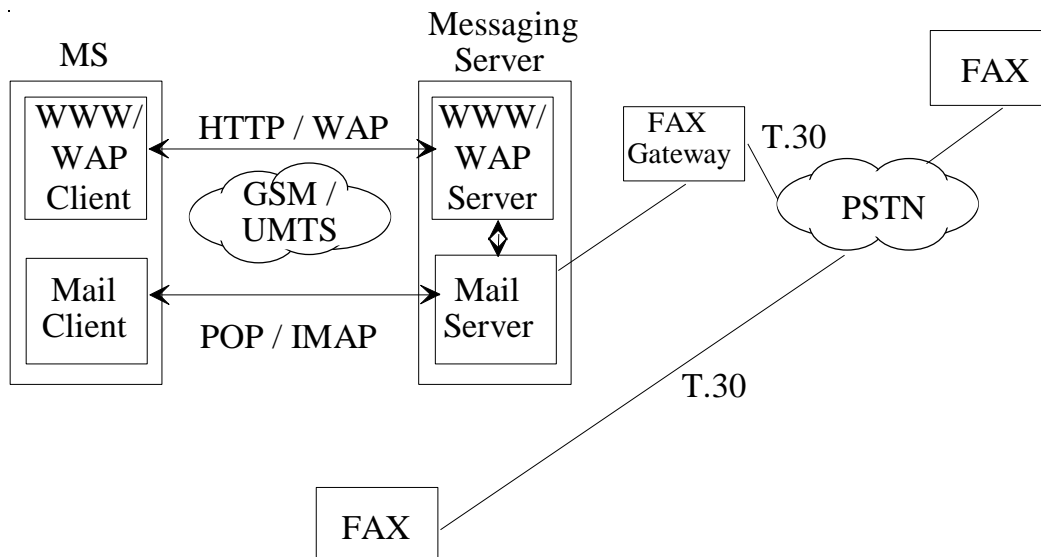

Figure 11: Facsimile and WWW / WAP combination scenario

8.5 Combining Facsimile and HLR functionality

If the mobile terminated T.30 facsimile call is not directly routed from the PSTN to the Fax gateway, but via the G-MSC of the PLMN, then the HLR functionality can be used, such as:-

- supplementary services, e.g. call forwarding to redirect the facsimile call to any other destination
- multi-numbering to identify a facsimile call and provide a appropriate routing of this call.
- charging
- subscription check.

This scenario implies that the Fax gateway is within the PLMN operators domain.

8.6 Integrating Facsimile within a Multimedia Message Service, MMS

The benefits achieved by combining the facsimile service with other already existing services are obvious, as previously outlined. Further advantages can be provided by integrating the facsimile into a MMS. The MMS must be understood as a non real-time transfer of different types of information in a store-and-forward fashion similar to the SMS. A Multimedia Message structure could provide fundamental properties of synchronising different media types, generic mechanisms to handle different terminal capabilities and appropriate notification principles. Furthermore, the MMS enables a unified user interface for integrating the composition, access and delivery of different kinds of media, e.g. text, voice, image or video and thus providing an unique service for SMS, Fax, e-mail, voice-mail, video-mail etc. The responsibility for such an MMS is within the PLMN operator's domain, meaning that an embedded facsimile service will also become an operator specific service and thus allow the integration of certain PLMN functions e.g. multi-numbering, subscription check, different charging models, the use of Supplementary Services and for appropriate notification, SMS.

The data access is not restricted to IP based services only. For example, USSD can be used alternatively to provide interoperability across different terminal classes. Figure 12 provides an example of how an MMS could be realised.

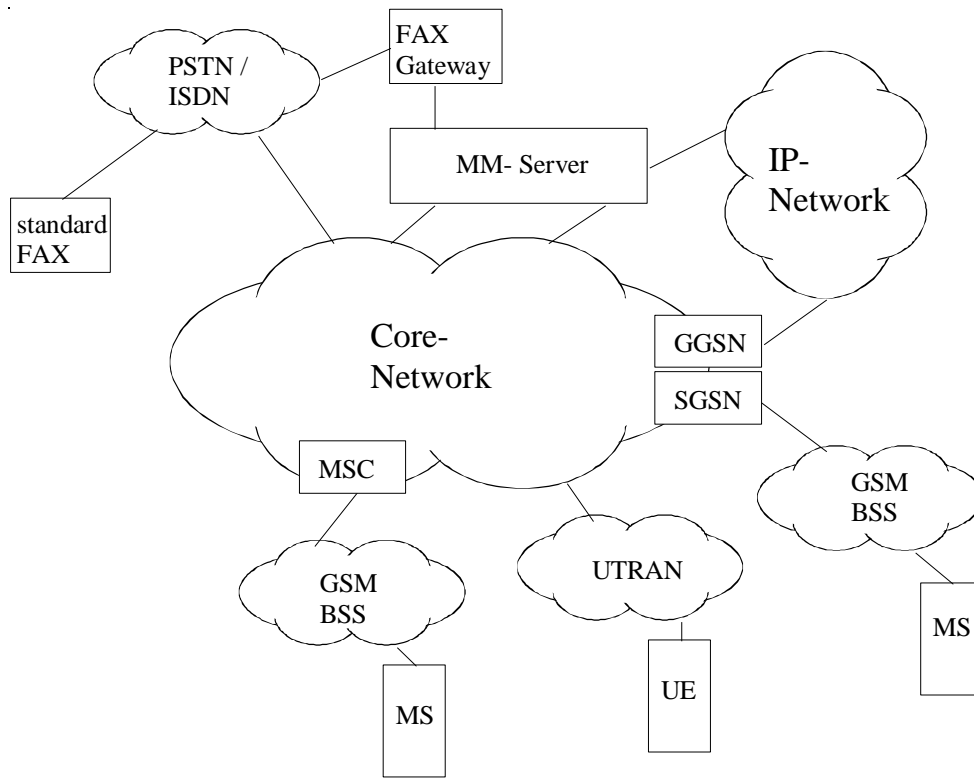

Figure 12: Example how an MMS could be realised in a UMTS and GSM/GPRS environment

History

Document history		
V 3.0.0	October 1999	TSG-T#5