

3GPP TS 22.234 V11.0.0 (2012-09)

Technical Specification

3rd Generation Partnership Project; Technical Specification Group Services and System Aspects; Requirements on 3GPP system to Wireless Local Area Network (WLAN) interworking (Release 11)



The present document has been developed within the 3rd Generation Partnership Project (3GPPTM) and may be further elaborated for the purposes of 3GPP.

The present document has not been subject to any approval process by the 3GPP Organizational Partners and shall not be implemented. This Specification is provided for future development work within 3GPP only. The Organizational Partners accept no liability for any use of this Specification. Specifications and reports for implementation of the 3GPPTM system should be obtained via the 3GPP Organizational Partners' Publications Offices.

Keywords

UMTS, radio, LAN

3GPP

Postal address

3GPP support office address

650 Route des Lucioles - Sophia Antipolis
Valbonne - FRANCE
Tel.: +33 4 92 94 42 00 Fax: +33 4 93 65 47 16

Internet

<http://www.3gpp.org>

Copyright Notification

No part may be reproduced except as authorized by written permission.
The copyright and the foregoing restriction extend to reproduction in all media.

© 2012, 3GPP Organizational Partners (ARIB, ATIS, CCSA, ETSI, TTA, TTC).
All rights reserved.

UMTS™ is a Trade Mark of ETSI registered for the benefit of its members
3GPP™ is a Trade Mark of ETSI registered for the benefit of its Members and of the 3GPP Organizational Partners
LTE™ is a Trade Mark of ETSI currently being registered for the benefit of its Members and of the 3GPP Organizational Partners
GSM® and the GSM logo are registered and owned by the GSM Association

Contents

Foreword	4
Introduction	4
1 Scope	5
2 References.....	5
3 Definitions and abbreviations	5
3.1 Definitions	5
3.2 Abbreviations.....	6
4 General description	6
5 High level requirements	7
5.1 Service principles	7
5.1.1 Numbering	7
5.1.2 USIM and UICC.....	7
5.1.3 Roaming.....	8
5.1.4 Charging	8
5.1.5 Subscription.....	8
5.1.6 Emergency calls	8
5.1.7 Interworking between PLMN and WLANs	8
5.1.7.1 General.....	8
5.1.7.2 Simultaneous connection to I-WLANs and 3GPP systems	10
6 Service requirements	10
6.1 Network selection	10
6.1.1 PLMN selection procedures	10
6.1.2 Dual mode 3GPP / WLAN devices.....	13
6.2 Operator Determined Barring	13
6.3 Support of PS domain services	13
6.4 Support for service continuity	13
6.5 Support of LCS	13
6.6 Support of IFOM	13
7 Charging	14
Annex A (informative): Change history.....	15

Foreword

This Technical Specification has been produced by the 3rd Generation Partnership Project (3GPP).

The contents of the present document are subject to continuing work within the TSG and may change following formal TSG approval. Should the TSG modify the contents of the present document, it will be re-released by the TSG with an identifying change of release date and an increase in version number as follows:

Version x.y.z

where:

- x the first digit:
 - 1 presented to TSG for information;
 - 2 presented to TSG for approval;
 - 3 or greater indicates TSG approved document under change control.
- y the second digit is incremented for all changes of substance, i.e. technical enhancements, corrections, updates, etc.
- z the third digit is incremented when editorial only changes have been incorporated in the document.

Introduction

Interworking of WLAN systems with the 3GPP system was the subject of a feasibility study [2]. Suitable requirements were derived and incorporated into existing specifications. For this release, all requirements will be contained in the present document with suitable references in other specifications to guide the reader to I-WLAN requirements.

1 Scope

The present document specifies the functional requirements placed on the 3GPP system for interworking WLAN with the 3GPP system. Guidance is given for WLAN operators intending to provide the interworked WLAN capability.

2 References

The following documents contain provisions which, through reference in this text, constitute provisions of the present document.

- References are either specific (identified by date of publication, edition number, version number, etc.) or non-specific.
- For a specific reference, subsequent revisions do not apply.
- For a non-specific reference, the latest version applies. In the case of a reference to a 3GPP document (including a GSM document), a non-specific reference implicitly refers to the latest version of that document *in the same Release as the present document*.

- [1] 3GPP TR 21.905: "Vocabulary for 3GPP Specifications".
- [2] 3GPP TR 22.934 (V6): "Feasibility study on 3GPP system to Wireless Local Area Network (WLAN) interworking".
- [3] RFC 2486: "The Network Access Identifier".
- [4] 3GPP TS 22.101: "Service principles".
- [5] 3GPP TS 22.129: "Handover Requirements between UTRAN and GERAN or other Radio Systems".
- [6] 3GPP TS 22.071: "Location Services (LCS); Stage1".
- [7] 3GPP TR 22.935: "Feasibility Study on Location Services (LCS) for Interworking-WLAN".
- [8] 3GPP TR 22.278: "Service requirements for the Evolved Packet System (EPS)".

3 Definitions and abbreviations

3.1 Definitions

For the purposes of the present document, the following terms and definitions apply

3GPP-WLAN Interworking: Used generically to refer to interworking between the 3GPP system and the WLAN family of standards

3GPP PS based services: All services transported by the 3GPP PS domain.

Environment: The type of area to be covered by the WLAN network of a 3GPP-WLAN interworking; e.g. public, corporate and residential

Home WLAN: The WLAN that is interworking with the HPLMN of the 3GPP-WLAN interworking user

Interworking WLAN: WLAN that interworks with a 3GPP system.

Offline Charging: See [1]

Online Charging: See [1]

Serving WLAN: The interworking WLAN that the user is connected to, i.e. either a visited or a home WLAN.

Visited WLAN: An interworking WLAN that interworks only with a visited PLMN.

WLAN coverage: An area where wireless local area network access services are provided for interworking by an entity in accordance with WLAN standards.

WLAN roaming: The ability for a 3GPP-WLAN interworking user (subscriber) to function in a serving WLAN different from the home WLAN

3.2 Abbreviations

For the purposes of the present document, the following abbreviations apply:

APN	Access Point Name
CDR	Charging Data Record
CS	Circuit Switched
GGSN	Gateway GPRS Support Node
GPRS	General Packet Radio Service
HPLMN	Home PLMN
IMS	IP Multimedia Subsystem
IP	Internet Protocol
IPv4	IP version 4
IPv6	IP version 6
I-WLAN	Interworked / interworking WLAN
LCS	Location Services
PDG	Packet Data Gateway
PLMN	Public Land Mobile Network
PS	Packet Switched
SIM	Subscriber Identity Module
UE	User Equipment
UICC	USIM Integrated Circuit Card
USIM	Universal Subscriber Identity Module
VPLMN	Visited PLMN
WLAN	Wireless Local Area Network

Further abbreviations are given in 3GPP TR 21.905 [1].

4 General description

The growth of public WLANs provides an opportunity for appropriately-equipped UEs to access HPLMNs and VPLMNs via the WLANs. As shown in Figure 1, the WLANs that provides this functionality are referred to as I-WLANs. The I-WLANs (represented by WLAN 1 through WLAN 3) are connected to PLMNs, enabling UEs to access 3GPP services on HPLMNs and VPLMNs. Services provided by WLANs directly to UEs that do not involve PLMNs are outside the scope of this specification. The solid lines identify elements that are within the 3GPP scope and the dashed lines identify elements which are not specified by 3GPP.

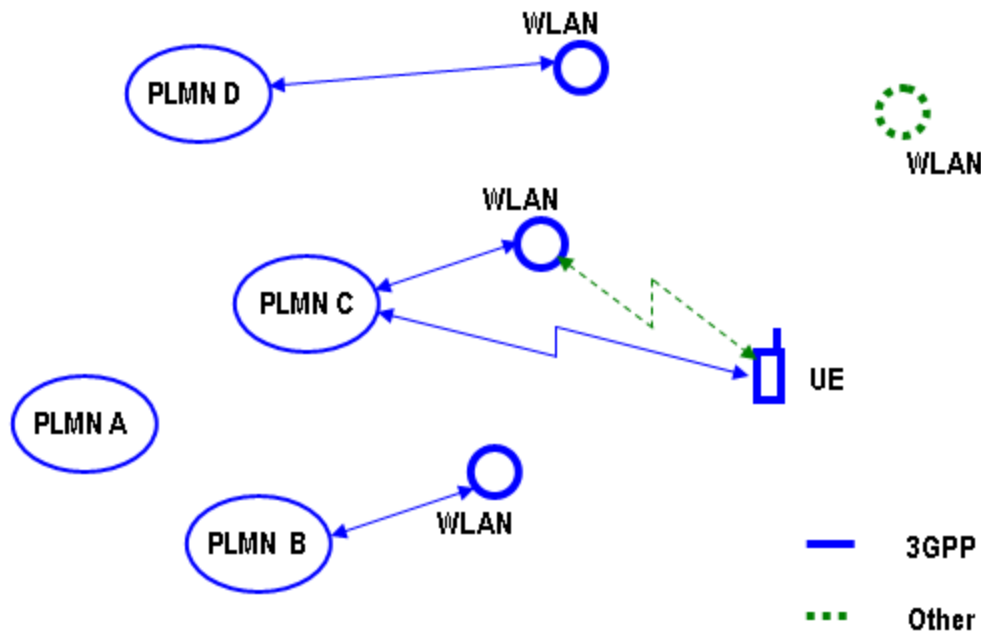

Figure 1: WLAN-3GPP system block diagram

Network selection shall ensure that the user is connected to the highest priority PLMN when the HPLMN is not available. As a consequence the preference of an I-WLAN and connected PLMN may change from one country to another, even when the I-WLAN identity is unchanged.

Only UEs with WLAN capability are within the scope of this specification.

It is expected that the UEs with both WLAN and 3GPP radio access network capability will exist.

The access to the WLAN (as shown by the dashed line) is covered by specifications outside of 3GPP. Thus UEs must conform to those specifications to access the WLAN and to the 3GPP specifications in order to obtain 3GPP services from PLMNs through I-WLANs. The UE will have access to 3GPP services when its registration is confirmed by its HPLMN.

NOTE: Detailed background information is provided in clause 4 of [2].

5 High level requirements

5.1 Service principles

5.1.1 Numbering

When the UE is connected via a I-WLAN, the addressing shall be based on Network Access Identifier (NAI) format (user@realm) as defined in RFC 2486 [3].

5.1.2 USIM and UICC

Access via an I-WLAN shall be possible using earlier releases (than the current release) of the UICC or using a SIM.

Access to services via an I-WLAN with a single UICC shall be possible.

I-WLAN access parameters include operator and user preferences on network selection. It shall be possible to store I-WLAN access parameters on the USIM.

For I-WLAN access and PLMN selection purposes, the WLAN UE shall by default use the I-WLAN access parameters stored in the UICC (if they are available).

5.1.3 Roaming

Roaming from the home environment to I-WLANs is required. The I-WLAN may be part of the home environment or a visited network. The interworking shall support the case where a 3GPP operator does not operate the I-WLAN.

5.1.4 Charging

Charging in the 3GPP system shall not be compromised when access is via an I-WLAN.

5.1.5 Subscription

The subscription to a network operator may identify the radio access technologies over which the subscriber may access their services e.g. I-WLAN.

5.1.6 Emergency calls

Any attempt to make an emergency call shall be handled as defined in 3GPP TS 22.101[4].

5.1.7 Interworking between PLMN and WLANs

5.1.7.1 General

WLAN-3GPP system interworking is defined as a wireless IP connectivity service where the user obtains access via a Wireless LAN technology. It shall be possible to deploy the WLAN as an integral part of the 3GPP system or the two systems can be separate.

The 3GPP system shall be capable of interworking with one or more WLANs and a WLAN shall be capable of interworking with one or more 3GPP systems see figure 2.

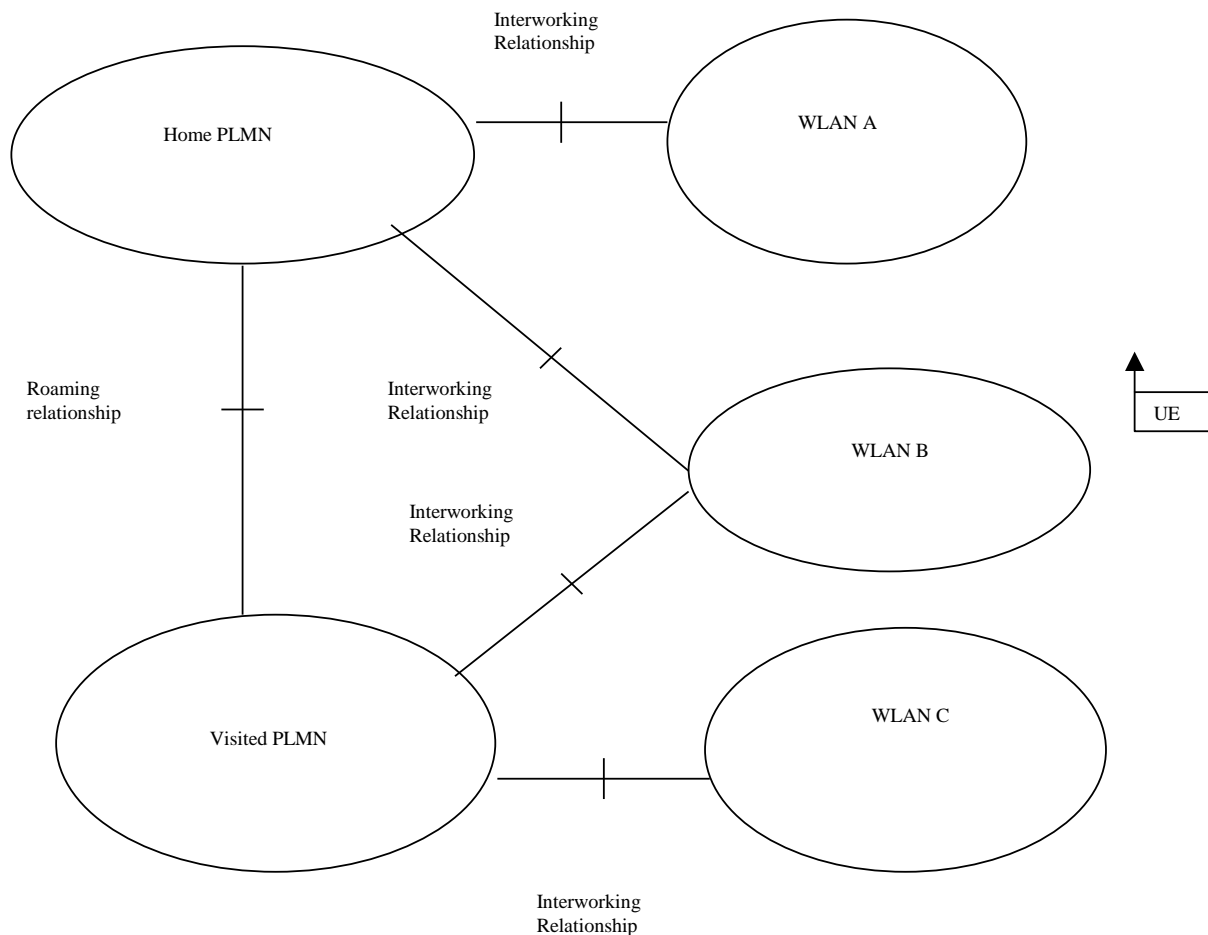

Figure 2: WLAN-3GPP system interworking relationships

The service is subject to a 3GPP system subscription (see clause 15). Both IPv4 and IPv6 connectivity via a Wireless LAN (WLAN) shall be supported.

It is an operator decision as to the level of interworking supported. This can be broadly grouped as:

- 3GPP based access control and charging only. (Scenario 2 of TR 22.934 [2])
- Access to 3GPP PS based services, e.g. IMS. (Scenario 3 of TR 22.934 [2])
- Access to 3GPP PS based services with service continuity. The user may or may not notice a disruption in service, depending upon the level of service continuity supported. This is further defined in TS 22.129 [5]. (Scenarios 4 and 5 of TR 22.934 [2])

NOTE: Further information on these levels of interworking and the use cases supported can be found in TR 22.934 [2].

The different levels of interworking supported are defined to be independent. Hence, it shall be possible for a network operator to provide a particular level of interworking independently to other levels of interworking.

NOTE: For example, it is possible for a network operator to provide a level of interworking to provide access to 3GPP PS based services (Scenario 3 of TR 22.934 [2]) without needing to provide the level of interworking for 3GPP based access control and charging (Scenario 2 of TR 22.934 [2]). In this case 3GPP USIM based authentication of the user is still needed before accessing 3GPP PS based services.

In addition to the general requirements on I-WLAN defined in the present document, the following requirements apply:

- When enabling access to 3GPP services that require separate authentication and access control, such as IMS, the service authentication and access control mechanisms for those services shall be used.
- It should be possible to provide access via I-WLAN on deployed WLAN devices.

5.1.7.2 Simultaneous connection to I-WLANs and 3GPP systems

The 3GPP system shall support simultaneous connection to an I-WLAN and to the 3GPP systems for the following scenarios:

- For an integrated WLAN/3GPP device the user shall be able to make or receive a CS domain call without the need to drop the connection to the I-WLAN and visa versa.
- For an integrated WLAN/3GPP device the user shall be able to connect to both the PS domain and to the I-WLAN at the same time, to access different services. For example, this will allow the user to access the Presence service via the 3GPP system and the internet via the I-WLAN.
- The user shall be able to connect simultaneously to the 3GPP system and the I-WLAN with multiple devices (which have separate UICCs) on the same subscription.

6 Service requirements

6.1 Network selection

The UE shall support both manual and automatic network selection mechanisms (modes) as standardized.

The UE shall use the last network selection mode used, as the default mode, at every switch-on.

The user shall be given the opportunity to change the network selection mode at any time. As an optional feature of the ME, the user shall be able to set a preference in the ME for the mode that shall be used at switch on. If set then the ME shall select this preference rather than the default mode.

When selecting a PLMN that is accessed via an interworked WLAN the UE shall be able to determine if the home or preferred PLMNs are available. The I-WLAN and PLMN selection shall adhere to operator and end user preferences using similar procedures as for Network Selection without WLAN interworking. This set of preferences may be different from the preferences used for direct 3GPP access. In manual network selection the user shall be able to request a list of available PLMNs via interworked WLANs. The detailed procedures are described below.

NOTE 1: The 3GPP operator may have agreements with multiple I-WLANs in the area and has preference over which WLAN to connect to based on the services supported.

NOTE 2: The adaptation of the Network Selection procedures to the WLAN interworking environment should take into account performance criteria (e.g. power consumption, network load).

NOTE 3: The preference of an I-WLAN and connected PLMN may change from one country to another, even when the I-WLAN identity is unchanged.

6.1.1 PLMN selection procedures

General

For the purpose of selecting a PLMN two lists may be present in the UICC: the "User Controlled PLMN Selector list for I-WLAN" and the "Operator Controlled PLMN Selector list for I-WLAN". It is not mandatory for the UICC to support these lists, however if the "Operator Controlled PLMN Selector list for I-WLAN" is supported then the "User Controlled PLMN Selector list for I-WLAN" shall also be present. Both lists contain the preferred PLMNs for I-WLAN in priority order, and the "User Controlled PLMN Selector list for I-WLAN" has higher priority than the "Operator Controlled PLMN Selector list for I-WLAN". Where the UE supports these lists, it shall utilise all the information stored in the USIM related to network selection, e.g. the information in the Operator controlled PLMN Selector list for I-WLAN and the User Controlled PLMN Selector list for I-WLAN.

The purpose of the procedure is to enable the WLAN UE to find an I-WLAN, however, in case no PLMN is found to be supported by any of the available WLANs, the behaviour of the UE is not specified.

For the purpose of selecting the preferred I-WLAN in case multiple I-WLANs can support the connection to the desired PLMN and for optimising the PLMN selection, two lists may be present in the UICC: the "User Controlled WLAN identities list for I-WLAN" and the "Operator Controlled WLAN identities list for I-WLAN". It is not mandatory for the

UICC to support these lists, however if the "Operator Controlled WLAN identities list for I-WLAN" is supported then the "User Controlled WLAN identities list for I-WLAN" shall also be present. Both lists contain the preferred WLAN identities in priority order, and the "User Controlled WLAN identities list for I-WLAN" has higher priority than the "Operator Controlled WLAN identities list for I-WLAN".

If the "Operator Controlled PLMN Selector list for I-WLAN" and the "Operator Controlled WLAN identities list for I-WLAN" are present, it shall be possible to efficiently update these lists over-the-air.

At switch on, when in coverage of the last accessed I-WLAN as stored in the UE, the UE shall attempt to register with the last accessed PLMN via that I-WLAN. As an option, if the UE finds that it is also in coverage of an I-WLAN that is known to support HPLMN connectivity whilst searching for the last accessed I-WLAN, the UE may attempt to register with that I-WLAN and then attempt to register on the HPLMN. The HPLMN shall be able to control, by USIM configuration, the UE behaviour.

The default behaviour for a UE is to select the last registered I-WLAN and PLMN accessed via that I-WLAN.

A) Automatic selection mode

In the automatic mode the WLAN UE shall perform the following procedure:

1. For each of the WLANs available the WLAN UE shall attempt to discover the PLMNs available via the particular I-WLAN. If the UICC contains I-WLAN identities' preference lists, this initial step shall be done in the order of the "User Controlled WLAN identities list for I-WLAN" and then the "Operator Controlled WLAN identities list for I-WLAN". For each I-WLAN, if the WLAN UE receives a list of available PLMNs, then
 - 1a) The UE shall select an EHPLMN if the EHPLMN list is present or the HPLMN (derived from the IMSI) if the EHPLMN list is not present. In the case that there are multiple EHPLMNs present then the highest priority EHPLMN shall be selected
 - 1b) If the HPLMN is not found, the UE creates a list of PLMNs accessible over the particular WLAN
2. Among all the PLMNs obtained in step 1b), select a PLMN following this order:
 - i) PLMNs contained in the "User Controlled PLMN Selector list for I-WLAN" data file in the USIM in priority order, if the list is available;
 - ii) PLMNs contained in the "Operator Controlled PLMN Selector list for I-WLAN" data file in the USIM in priority order, if the list is available;
 - iii) PLMNs contained in the "User Controlled PLMN Selector list with access technology", if available;
 - iv) PLMNs contained in the "Operator Controlled PLMN Selector list with access technology", if available;
 - v) PLMNs contained in the optional "User Controlled PLMN Selector list for I-WLAN" in the ME in priority order, if the list is available;
 - vi) PLMNs contained in the optional "Operator Controlled PLMN Selector list for I-WLAN" in the ME in priority order, if the list is available;
 - vii) any other PLMN not included in the lists (randomly)
3. Attempt association with the highest priority I-WLAN in the I-WLAN identities' preference list (if available) providing connection to the PLMN selected in step 2 and attempt authentication with the selected PLMN.

B) Manual selection mode

In manual selection mode the WLAN UE shall perform the following procedure:

1. For each of the available WLANs the WLAN UE shall attempt to discover the PLMNs available via the particular WLAN.
2. If the WLAN UE receives a list of available PLMNs, then the WLAN UE presents the available PLMNs in the following order:

- i) HPLMN (if the EHPLMN list is not present); or if one or more of the EHPLMNs are available then based on an optional data field on the USIM either the availability of the highest priority EHPLMN is to be presented to the user or all available EHPLMNs are presented to the user in priority order; if the data field is not present, then only the availability of the highest priority EHPLMN is presented;
- ii) PLMNs contained in the "User Controlled PLMN Selector list for I-WLAN" data file in the USIM in priority order, if the list is available;
- iii) PLMNs contained in the "Operator Controlled PLMN Selector list for I-WLAN" data file in the USIM in priority order, if the list is available;
- iv) PLMNs contained in the "User Controlled PLMN Selector list with access technology", if available;
- v) PLMNs contained in the "Operator Controlled PLMN Selector list with access technology", if available;
- vi) PLMNs contained in the optional "User Controlled PLMN Selector list for I-WLAN" in the ME in priority order, if the list is available;
- vii) PLMNs contained in the optional "Operator Controlled PLMN Selector list for I-WLAN" in the ME in priority order, if the list is available;
- viii) any other PLMN not included in the lists (in random order)

In case more than one I-WLAN gives access to the same PLMN, an indication of the I-WLAN identity should also be presented to the user. The HPLMN of the user may provide on the USIM additional information about the available PLMNs, if this is provided then the UE shall indicate that information that may be displayed to the user. This information, provided as free text may include:

- Preferred partner,
- roaming agreement status,
- supported services

Furthermore, the UE may indicate whether the available PLMNs are present on one of the PLMN selector lists (e.g, User Controlled PLMN Selector list for I-WLAN or Operator Controlled PLMN Selector list for I-WLAN) as well as not being present on any of the lists.

NOTE: it is possible to have repetitions of the same PLMN in the list presented to the user

3. Upon user selection of the desired PLMN the WLAN UE shall attempt to register on this PLMN. If more than one I-WLAN offers connection to the selected PLMN, then the WLAN UE shall attempt registration via the selected I-WLAN. To do so, the WLAN UE associates with the I-WLAN supporting the PLMN selected by the user and attempt authentication.

C) Steering of Roaming

Steering to a specific I-WLAN PLMN

It shall be possible for the HPLMN at any time to direct the UE to search for a specific PLMN connected by I-WLAN and, if it is available, move to that PLMN as soon as possible unless the UE is in manual mode. This PLMN shall then be regarded as the highest priority PLMN as defined by the operator. This process shall be done transparently and without inconvenience to the user.

I-WLAN PLMN Redirection

It shall be possible for the HPLMN to request the UE to find and register on a different PLMN connected by I-WLAN from the one it is currently using or trying to register on if another PLMN is available. If the UE is in manual mode the UE shall ignore this request. The original PLMN shall then be treated as the lowest priority PLMN and would not be selected by the UE unless it is the only one available to the UE or has been selected in manual mode.

This process shall be done transparently and without inconvenience to the user.

6.1.2 Dual mode 3GPP / WLAN devices

The UE shall select between the available 3GPP systems and the WLANs by using similar procedures as for Network Selection without WLAN Interworking.

NOTE 1: The 3GPP operator may have agreements with multiple WLANs in the area and has preference over which WLAN to connect to based on the services supported.

6.2 Operator Determined Barring

Access to services via an interworking WLAN is different in nature to circuit and other 3GPP packet oriented services, and therefore has different requirements for Operator Determined Barring.

As described in the following categories, the Service Provider may at any time activate this feature and this shall terminate any relevant services in progress, and bar future requests for service covered by the barring category:

- It shall be possible to bar subscribers attached via an Interworking WLAN completely from the interworked service capabilities.
- It shall be possible to bar a subscriber from requesting interworking through access points that are within the HPLMN whilst the subscriber is WLAN connected via a VPLMN
- It shall be possible to bar a subscriber from requesting packet-oriented services from access points that are within the roamed to VPLMN.
- It shall be possible to bar a subscriber from requesting direct Internet access from access points that are within the I-WLAN

The term 'access point' is used to indicate the Network Element (e.g. PDG or GGSN) or part of the Network Element (e.g. PDG or GGSN) that is specified by a particular APN.

6.3 Support of PS domain services

I-WLAN shall support all services based on 3GPP System PS domain capabilities (e.g. IMS).

Support of real time IMS services will require QoS support in I-WLAN. If the I-WLAN does not offer sufficient support for QoS, best effort approach may be used.

When enabling access to 3GPP services that require separate authentication and access control, such as IMS, the service authentication and access control mechanisms for those services shall be used.

6.4 Support for service continuity

Service continuity between I-WLAN and 3GPP systems which allows ongoing 3GPP PS based services to survive a change of the access network shall be provided.

A change in service quality may occur as a consequence of the transition between systems due to the varying capabilities of the access technologies and their associated networks. As the target network may not support an equivalent service, it is possible that some services may not survive.

6.5 Support of LCS

The I-WLAN system shall be able to support LCS [6, 7].

6.6 Support of IFOM

The I-WLAN system shall be able to support IFOM as described in the related chapter of reference [8].

7 Charging

The advent of I-WLAN may further enhance the ease of use for the mobile system user and virtually extend the effective coverage areas of each system. It shall be possible to charge the user for services offered by the interworking between WLAN and 3GPP system in terms of access, usage, etc which is an operator decision as to the level of interworking supported.

It shall be the role of the 3GPP system to process the I-WLAN access resource usage information into 3GPP compatible format (e.g. CDR).

Annex A (informative): Change history

Change history											
TSG SA#	SA Doc.	SA1 Doc	Spec	CR	Rev	Rel	Cat	Subject/Comment	Old	New	WI
01/2004		S1-040250	22.234					Creation of TS		2.0.0	WLAN
SA-23	SP-040100	S1-040250	22.234			Rel-6		Approved at SA #23	2.0.0	6.0.0	WLAN
SP-24	SP-040295	S1-040527	22.234	0001	-	Rel-6	F	Priority usage of UICC parameters for I-WLAN	6.0.0	6.1.0	WLAN-CR
SP-24	SP-040294	S1-040528	22.234	0002	-	Rel-6	F	Addition of a definition of 3GPP PS based services	6.0.0	6.1.0	WLAN
SP-24	SP-040294	S1-040531	22.234	0003	-	Rel-6	C	TS 22.234 Addition of clause 4. General Description	6.0.0	6.1.0	WLAN
SP-24	SP-040475	S1-040549	22.234	0004	1	Rel-6	B	Selection of a PLMN accessed via an I-WLAN	6.0.0	6.1.0	WLAN
SP-25	SP-040506	S1-040710	22.234	0005	-	Rel-6	F	Clarification to WLAN PLMN Selection	6.1.0	6.2.0	WLAN
SP-25	SP-040506	S1-040711	22.234	0006	-	Rel-6	F	Use of the SSID List at WLAN PLMN Selection	6.1.0	6.2.0	WLAN
SP-25	SP-040506	S1-040712	22.234	0007	-	Rel-6	F	Clarification of Interworking between PLMN and WLANs clause 5.1.7.1	6.1.0	6.2.0	WLAN
SP-25	SP-040506	S1-040715	22.234	0008	-	Rel-6	F	Clarification of the relationship between different levels of WLAN interworking	6.1.0	6.2.0	WLAN
SP-25	SP-040506	S1-040726	22.234	0009	-	Rel-6	F	Clarification on the WLAN identities lists for I-WLAN selection	6.1.0	6.2.0	WLAN
SP-26	SP-040737	S1-040995	22.234	0010	-	Rel-7	B	New features of I-WLAN	6.2.0	7.0.0	WLAN-SC
SP-27	SP-050066	S1-050206	22.234	0011	-	Rel-7	C	Over-the-air update of I-WLAN operator lists	7.0.0	7.1.0	WLAN-SC
SP-27	SP-050066	S1-050209	22.234	0012	-	Rel-7	F	Editorial change and addition of missed abbreviation	7.0.0	7.1.0	WLAN-SC
SP-27	SP-050061	S1-050208	22.234	0014	-	Rel-7	A	Requirements for Support of 3GPP PS services	7.0.0	7.1.0	WLAN-CR
SP-28	SP-050222	S1-050525	22.234	0017	-	Rel-7	F	Correction of a faulty reference in 22.234	7.1.0	7.2.0	TEI7
SP-28	SP-050222	S1-050532	22.234	0018	-	Rel-7	B	Clarification of LCS in I-WLAN	7.1.0	7.2.0	I-WLAN, LCS
SP-30	SP-050739	S1-051234	22.234	0019	-	Rel-7	F	Addition of missing reference in TS 22.234	7.2.0	7.3.0	I-WLAN
SP-32	SP-060305	S1-060587	22.234	0021	-	Rel-7	A	Deletion of ODB requirements on direct internet access and WLAN 3GPP IP Access	7.3.0	7.4.0	WLAN-SC
SP-34	SP-060921	-	22.234	0022	-	Rel-7	B	Re-introduction of ODB for I-WLAN	7.4.0	7.5.0	WLAN-SC
SP-35	SP-070123	S1-070093	22.234	0023	-	Rel-8	F	Capability of UE to read USIM information for I-WLAN Network Selection	7.5.0	8.0.0	IWLANNSP
SP-35	SP-070123	S1-070266	22.234	0024	1	Rel-8	B	Steering of Roaming for PLMNs connected by I-WLAN	7.5.0	8.0.0	IWLANNSP
SP-35	SP-070123	S1-070267	22.234	0025	1	Rel-8	B	Requirement for presentation of additional information in manual mode	7.5.0	8.0.0	IWLANNSP
SP-35	SP-070123	S1-070268	22.234	0026	1	Rel-8	B	Network selection mode at switch-on	7.5.0	8.0.0	IWLANNSP
SP-36	SP-070480	S1-070648	22.234	0027	1	Rel-8	B	The Last RPLMN	8.0.0	8.1.0	IWLANNSP
SP-36	SP-070363	S1-070651	22.234	0028	-	Rel-8	B	Addition of EHPLMN to I-WLAN selection	8.0.0	8.1.0	IWLANNSP
SP-46	SP-090848	S1-094464	22.234	0031	2	Rel-10	B	Adding reference to 22.278 for IFOM Requirements	8.1.0	10.0.0	IFOM
2012-09	-	-	-	-	-	-	-	Updated to Rel-11 by MCC	10.0.0	11.0.0	-