

3GPP TS 22.233 V11.0.0 (2012-09)

Technical Specification

**3rd Generation Partnership Project;
Technical Specification Group Services and System Aspects;
Transparent end-to-end packet-switched streaming service;
Stage 1
(Release 11)**



The present document has been developed within the 3rd Generation Partnership Project (3GPPTM) and may be further elaborated for the purposes of 3GPP.

The present document has not been subject to any approval process by the 3GPP Organizational Partners and shall not be implemented. This Specification is provided for future development work within 3GPP only. The Organizational Partners accept no liability for any use of this Specification. Specifications and reports for implementation of the 3GPPTM system should be obtained via the 3GPP Organizational Partners' Publications Offices.

Keywords

UMTS, packet mode, stage 1

3GPP

Postal address

3GPP support office address

650 Route des Lucioles – Sophia Antipolis
Valbonne – FRANCE
Tel. : +33 4 92 94 42 00 Fax : +33 4 93 65 47 16

Internet

<http://www.3gpp.org>

Copyright Notification

No part may be reproduced except as authorized by written permission.
The copyright and the foregoing restriction extend to reproduction in all media.

© 2012, 3GPP Organizational Partners (ARIB, ATIS, CCSA, ETSI, TTA, TTC).
All rights reserved.

UMTS™ is a Trade Mark of ETSI registered for the benefit of its members
3GPP™ is a Trade Mark of ETSI registered for the benefit of its Members and of the 3GPP Organizational Partners
LTE™ is a Trade Mark of ETSI registered for the benefit of its Members and of the 3GPP Organizational Partners
GSM® and the GSM logo are registered and owned by the GSM Association

Contents

Foreword	4
Introduction	4
1 Scope	5
2 References.....	5
3 Definitions and abbreviations	5
3.1 Definitions	5
3.2 Abbreviations.....	6
4 Entities involved in Streaming service	6
5 Service Requirements.....	7
5.1 General	7
5.2 Media Types.....	8
5.3 Multimedia Composition and Interaction.....	9
5.4 Transport.....	9
5.5 Service Personalization	10
5.6 Service Management.....	10
6 Security	11
7 Charging	11
8 Digital Rights Management	11
9 Interworking.....	11
10 Service Interaction	11
Annex A (informative): PSS Examples	13
Annex B (informative): Change history.....	15

Foreword

This Technical Specification has been produced by the 3rd Generation Partnership Project (3GPP).

The contents of the present document are subject to continuing work within the TSG and may change following for mal TSG approval. Should the TSG modify the contents of the present document, it will be re-released by the TSG with an identifying change of release date and an increase in version number as follows:

Version x.y.z

where:

x the first digit:

- 1 presented to TSG for information;
- 2 presented to TSG for approval;
- 3 or greater indicates TSG approved document under change control.

Y the second digit is incremented for all changes of substance, i.e. technical enhancements, corrections, updates, etc.

z the third digit is incremented when editorial only changes have been incorporated in the document.

Introduction

3G mobile systems, through the increase in available bandwidth, offer new possibilities and services. One of these new services will be the ability to stream sound and movies to mobile devices.

Streaming is a mechanism whereby media content can be rendered at the same time that it is being transmitted to the client over the data network.

Streaming services are required whenever instant access to multimedia information needs to be integrated into an interactive media application. This has to be seen in contrast to other multimedia services like for instance MMS where multimedia content is delivered to the user asynchronously by means of a “message”.

Interactive applications that use streaming services include on-demand and live information delivery applications. Examples of the first category are music, music videos and news-on-demand applications. Live delivery of radio and television programs are examples of the second category, this could e.g. make it possible to listen to domestic radio while abroad.

A web server works with requests for information, it delivers that particular information as fast as possible, completes the transaction, disconnects and goes on to other requests. A client connects to a web server only when it needs information. This strategy works well as long as pictures and text are to be received. If a client wants to watch video or listen to audio, the entire file must be received before it can be played. The problem is that these kinds of files can be very large thus potentially causing storage problems in the client and resulting in long start-up latency. A streaming service improves this by allowing the media to be consumed as it is received, thereby reducing the latency and removing the need to store the media.

In addition to providing the streaming mechanism the PSS also encompasses the composition of media objects thereby allowing compelling multimedia services to be provisioned. For instance, a mobile cinema ticketing application would allow the user to view the film trailers.

1 Scope

This Technical Specification defines the stage one description of the Packet-switched Streaming Service (PSS). Stage one is the set of requirements that shall be supported for the provision of a streaming service, seen primarily from the user's and service providers' points of view but also includes the service capabilities of the PSS itself

This TS includes information applicable to network operators, service providers, terminal and network manufacturers.

This TS contains the core requirements for the Packet-switched Streaming Service (PSS), which are sufficient to enable a range of services.

2 References

The following documents contain provisions which, through reference in this text, constitute provisions of the present document.

- References are either specific (identified by date of publication, edition number, version number, etc.) or non-specific.
- For a specific reference, subsequent revisions do not apply.
- For a non-specific reference, the latest version applies. In the case of a reference to a 3GPP document (including a GSM document), a non-specific reference implicitly refers to the latest version of that document *in the same Release as the present document*.

- [1] Void
- [2] Void
- [3] 3GPP TS 22.105: "Services and Service Capabilities".
- [4] 3GPP TS 26.233: "Transparent End to End Packet Switched Streaming Service (PSS): General Description".
- [5] 3GPP TS 26.234: "Transparent End to End Packet Switched Streaming Service (PSS): Protocol and Codecs".
- [6] 3GPP TS 21.905: "Vocabulary for 3GPP specifications".
- [7] Void
- [8] IETF RFC 2046: "Multipurpose Internet Mail Extensions (MIME) part 2: media types".
- [9] 3GPP TS 22.242: "Digital Rights Management (DRM)".

3 Definitions and abbreviations

3.1 Definitions

Client: in the context of Streaming Service the client is a device (or service) that receives media objects and/or multimedia composition instructions from a server.

Media Type: a type of media e.g. text, audio, video, graphics (see section 5.2)

Media Object: an instance of a media type (e.g. a picture) or a combination of instances of media types (e.g. a video clip that includes audio)

Media Attribute: an attribute of a media object depending on the media type e.g. the colour of a piece of text

Multimedia Composition: the position in time and space of media objects relative to one another

Multimedia Services: Services that handle several types of media such as audio and video in a synchronised way from the user's point of view. A multimedia service may involve multiple parties, multiple connections, and the addition or deletion of resources and users within a single communication session.

Server: in the context of the Streaming Service the server is a device (or service) that delivers media objects and/or multimedia composition instructions in response to client requests.

Streaming: a mechanism whereby media content can be rendered at the same time that it is being transmitted to the client over the data network.

Streaming Service: an alternative way of referring to the PSS.

Terminal Profile: Set of information about the physical capabilities of the terminal.

User Profile: Is the set of information necessary to provide a user with a consistent, personalised service environment, irrespective of the user's location or the terminal used (within the limitations of the terminal and the serving network).

3.2 Abbreviations

For the purposes of the present document, the abbreviations given in TR 21.905 [6] and the following apply. An abbreviation defined in the present document takes precedence over the definition of the same abbreviation, if any, in TR 21.905 [6].

CODEC	Coder / DECoder
MMS	Multimedia Messaging Service
PS	Packet Switched
PSS	Packet Switched Streaming Service
QoS	Quality of Service
UE	User Equipment

4 Entities involved in Streaming service

The figures 01 and 02 shows the basic entities involved in the Streaming service and how they connect.

Clients initiate the service and connect to the selected content server. Content servers can generate live content e.g. video from a concert. User profile and terminal capability data can be stored on a network server and will be contacted at the initial set up. User Profile will provide the Streaming service with the user's preferences. Terminal capabilities will be used by the Streaming service to decide whether or not the client is capable of receiving the streamed content.

Portals are servers allowing convenient access to streamed media content. For instance, a portal might offer content browse and search facilities. In the simplest case, it is simply a Web/WAP-page with a list of links to streaming content. The content itself is usually stored on content servers, which can be located elsewhere in the network.

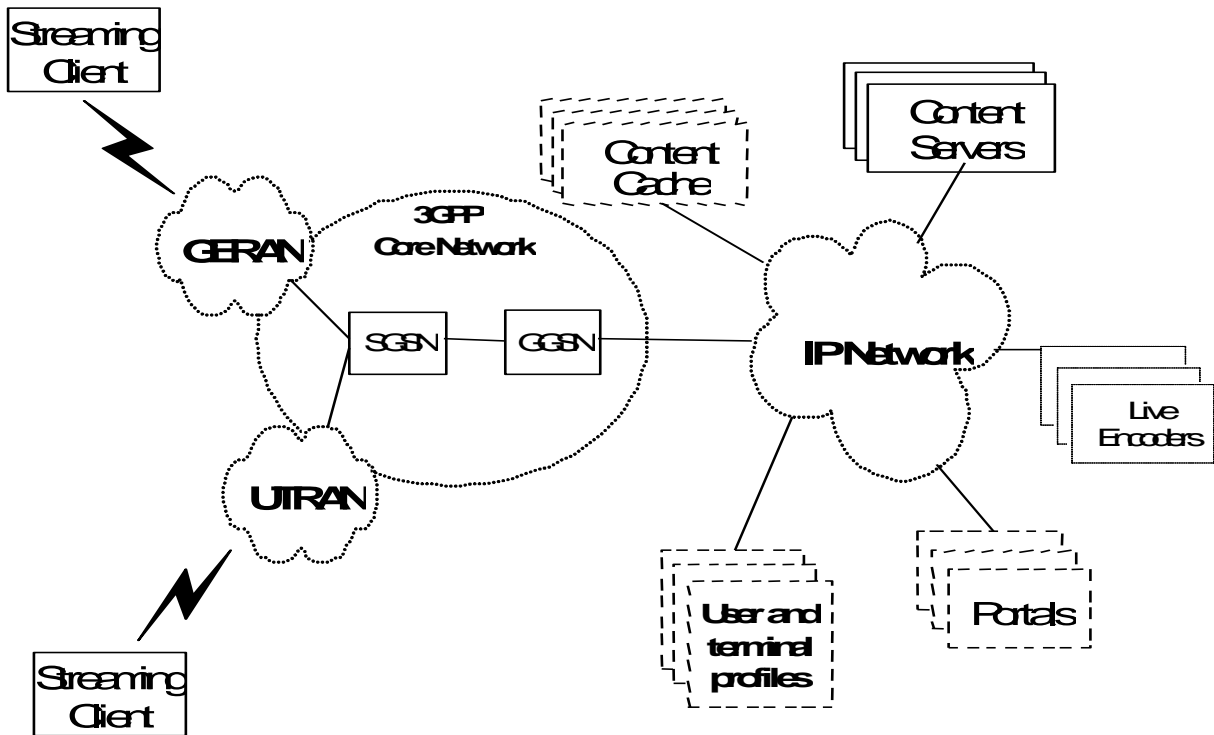

Figure 01: Network elements involved in a 2G/3G packet switched streaming service for GPRS core

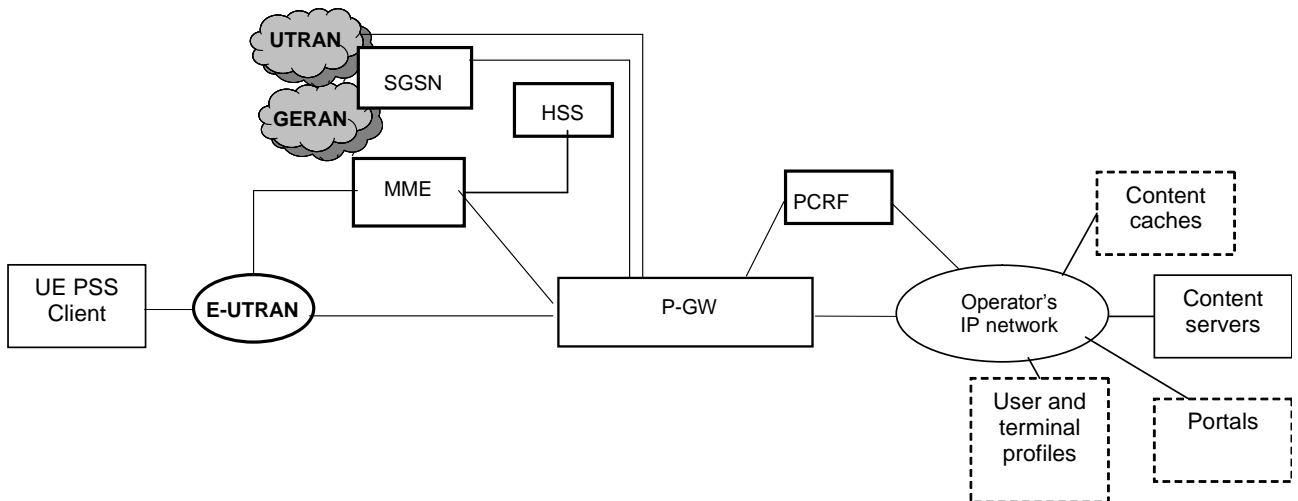

Figure 02: Network elements involved in a 2G/3G and LTE packet switched streaming service for EPC

5 Service Requirements

5.1 General

Stage 2 implementations are shown in TS 26.233 [4] and stage 3 in TS 26.234 [5].

The PSS uses a Client / Server model. The client controls the server by sending requests to the server, which responds to these commands.

- The PSS shall support downlink streaming.
- The PSS shall maintain backwards compatibility (i.e. a Rel-4 client should be able to interoperate with a Rel-5 server and vice versa).
- The PSS should consider interoperability with streaming elements (protocols, formats etc) already in use in other industries (e.g. the internet).
- The PSS shall support access to live content in addition to pre-authored content. E.g. ability to listen to domestic radio station whilst abroad.
- It shall be possible for an operator to configure a PSS television service so that the typical channel switching time, from the end user's perspective, does not exceed 2 seconds. A PSS television service may include live content offering or video on-demand content offering.
- PSS should allow support for time shifted live media consumption and bookmarks.
- The PSS should be able to support mechanisms that allow for efficient usage of transport resources (e.g. by compression of data in PSS). Such mechanisms should have no or minimal impacts on the core network and access networks.

Note: Such mechanisms may not be available for all streamed content.

- The PSS shall:
 - use open standards where these are available for Streaming service requirements
 - use standard procedures and interfaces to avoid interoperability problems among client, server and encoder
 - The live PSS shall define an interaction procedure to provide interoperability between server and encoder.
 - The live PSS shall define an interaction procedure to provide interoperability between server and server.
 - use extensions to existing standards if needed

5.2 Media Types

- The PSS should support multiple media types (see ref [5]) to enable rich, compelling multimedia services, for example:
 - Audio (including speech)
 - Video
 - Still image
 - Graphics (2D and 3D) including animation and Timed Graphics
 - Text
 - Plain text
 - Formatted text e.g. size, colour, font
 - Timed Text
 - Synthetic audio (e.g. MIDI)
 - Metadata e.g. indication that text has been supplied for the hard of hearing
- The number of implementations of each media type shall be kept to a minimum, considering the implementation impact to the terminals, interoperability, contents mobility and backward compatibility.
- The PSS shall share media codecs with other 3G multimedia services to allow easy interworking when needed.

- The PSS should be able to call upon a font that is available across all terminals, either by use of an agreed default font in all terminals or by downloading the font prior to display. This requirement applies to formatted text only and is dependent upon the terminal capability.

5.3 Multimedia Composition and Interaction

- The PSS shall enable the creation of multimedia services incorporating multiple media objects.
- The PSS shall provide the capability to position and synchronise media objects on the client.
- The PSS shall support flowing/scrolling of text or graphics in any direction.
- The PSS shall provide the capability to specify the media attributes – text (e.g. colour, size, font, format) or graphics (e.g. size, colour) – in relation to the timebase of other media objects. E.g. in a karaoke application where the audio track and song lyrics are downloaded together, it should be possible to not only display the song lyrics in time to the music but to display the lyrics in different colours to indicate to the user when to sing them
- The PSS shall provide the capability to update media objects dynamically. E.g. substitution of news report with a more up to date version on the content server.
- The PSS should provide the capability to update the attributes of media objects dynamically. E.g. colour coded pre-paid indicator to indicate credit level.
- The PSS should provide the capability to update the multimedia composition dynamically. E.g. the user interacts with the application and changes a scene.
- The PSS shall provide the capability that allows the user to navigate through or interact with the multimedia service. E.g. Once a user has downloaded a “tour of London” application the user has the ability to navigate through London and see video clips or hear audio descriptions of points of interest in London.
- The PSS shall provide the capability that allows clients of different capabilities to maximise the user experience. E.g. if a client did not support graphic animations it could render a single image.
- The PSS shall support the transfer to the terminal of information on the accessed content in addition to the filename (e.g. song title, artist).

5.4 Transport

- The PSS transport shall be provided by the PS Domain.
- Quality of Service (e.g. time delay) requirements shall be in accordance with requirements in 22.105 (ref. 3)
- The PSS should be able to work over different QoS bearers.
- The PSS shall provide a mechanism whereby the client is sent a list of media encoding bit rates and the client determines which one to use based on the network service bearers offered and the user preferences.
- The PSS client shall be capable of requesting an appropriate level of QoS for the session. The QoS supplied may be limited by the local operator’s access policy and/or network functionality.
- The PSS should provide mechanisms for streaming servers and clients to adapt to the network conditions in order to achieve significant improvement in the quality of streaming, e.g. using information on end-to-end transport quality from the network.
- The PSS should provide a reliable delivery mechanism that enables the user to receive the content without any errors due to the transport mechanism, i.e. a delivery mechanism without bit errors or packet loss. Such mechanism should support the following features :
 - The rendering of video content without any transport degradation : the content is downloaded without any errors, it assures that the subscribers see the content that has been designed by the content creators.

Note: User expectation of live video is related to the fact that it is delivered without interruptions or long delays. As such, reliable delivery mechanism is not considered for rendering of live video content (under poor conditions it might even be difficult to achieve). - The rendering of the content should start before the transfer is complete.

- A broken session should be restarted efficiently without going back to the beginning : the PSS client is able to detect what content is missing and to ask the server to send this content.

Note: In addition to the regular PSS transport mechanism it is possible to use download transport mechanisms in the following way: Audiovisual data encapsulated in a file is transmitted from the server to the client. The user is able to play the content during the file download, giving a similar look and feel to the regular PSS transport mechanism.

5.5 Service Personalization

- The PSS should support the ability for the client to have specific preferences described in the user profile. For example, if the user wants to watch a news show the preferred language (speech or subtitles) is specified in the user profile
- The PSS shall support a basic set of terminal capabilities.
- For the purpose of optimised presentation of the media streaming, PSS shall include capability exchange and negotiation mechanisms on server/client capabilities and user preferences at the session set up.
- The client should be able to send user preferences to the server during a streaming session. E.g. the user may toggle between mono and stereo sound.

5.6 Service Management

User's control of the service:

- The client shall initiate the streaming session.
- The user shall have the possibility to stop the streaming session after it has been invoked.
- The user shall have the possibility to pause the streaming session after it has been invoked. E.g. if a user has activated the streaming session and then gets a phone call, he/she shall be able to decide whether or not he/she wants the streaming session to continue. After a pause the user can choose to resume the streaming session.
- The PSS should be able to simultaneously handle the streaming session and conversational (circuit or packet?) services (e.g. voice and video telephony)
- The user shall have the possibility of jumping to another point within the media clip (i.e., random access)
- The user should be able to search through media content whilst viewing the content.
- If the content is available under different formats corresponding to the terminal capabilities and user preferences, the client should have the opportunity to choose the format for which the content will be streamed. Assuming the user has already set the user profile and the client is aware of this.

Service Provider's management of the service:

- The end user should be notified if the PSS is unavailable.
- The Streaming session should be gracefully disconnected if the client is not capable of handling the streamed content.
- The service provider should have the means by which a streaming session can be gracefully terminated (e.g. in a prepay scenario when the user's account has run out of credit)
- The PSS should be able to support real-time quality of service metrics data from the UE.

6 Security

The user shall be able to use the PSS in a secure manner. Mechanisms shall be provided to ensure that the media objects are only sent to and accessed by the intended end-user(s).

- PSS shall support end-to-end security (e.g. between the server and the Streaming client).

7 Charging

PSS should support various charging mechanisms, for example, time base charging, volume based charging, event based charging, content based charging.

It shall be possible to include the following streaming specific data, as a minimum, in the CDRs as charging information:

- streaming type (e.g. real-time or non real-time),
- volume of streaming content delivered
- volume of data delivered
- time of start of delivery
- duration
- Qos, including transmission rate, packet loss ratio, transfer delay(latency ,jitter),
- Streaming service sender / -recipient
- number of Streaming events sent
- number of Streaming events received.
- Media type
- Content id (the particular content stream being accessed)

8 Digital Rights Management

PSS shall support the 3GPP DRM mechanism (see ref [9])

9 Interworking

The standard shall permit interworking with other streaming technologies.

10 Service Interaction

- The PSS shall define a common file format (common to all download mechanisms) for easy service interaction with other multimedia delivery services defined in 3GPP (e.g. MMS).
- It shall be possible for the PSS to interact with the MMS and other 3GPP multimedia delivery services. The interfaces and protocols used between the PSS and other 3GPP multimedia delivery services shall be standardized.

Note : Service interaction with MMS is especially important because there are application scenarios where media delivery via a streaming service could be replaced by media delivery via MMS and vice versa.

- The PSS shall define a server file format to provide easy interoperability between Content Creators and Service Providers.

Annex A (informative): PSS Examples

Some domains may benefit from the convenient, ubiquitous and more reachable mobile device. A second challenge for operators and service providers is to utilise the ‘mobile’ effect for providing value-added services. We believe successful wireless data services will exploit the unique mobile characteristics. A non-exhaustive list of these mobile service characteristics can be presented as follows:

- **Content everywhere:** Locally interactive content and remote interaction (back-channels) in relation to interactive streamed media, including rewind/pause functions will define the key features for providing attractive and friendly contents for distance learning applications and other information services (news, financial, etc). Scanning headlines of daily newspapers is already about to become a popular ‘waiting time’ activity. In the learning context, one may imagine that a student will be able to select on his portal page the school section from which he will be able to view a list of classes that will take place and to preview current live lectures, required readings, etc.
- **Lifestyle facilitators:** When discovering a tourism site one may want access to leisure and travel information (e.g., flight deals, package holidays, quality hotels, fun activities, etc). During weekend outings and holidays, a common use case will be the following: one uses the location finder to find the nearest shop where he can find the desired object at the desired price, a navigation guide helps him to determine how he will get to the shop or store.
- **Entertainment services:** Gaming is already being touted as the biggest generator of minutes of use for interactive cellular services in Asia and Europe. Features such as streamed 2D graphics, 3D objects, complex animations and multi-user technologies will attract more subscribers by allowing richer experiences with more fancy navigation schemes. As an example of future scenario, when online-games will become very popular, 3D-graphics of the new multimedia mobile phones allow a bunch of fancy games. Players can join multi-user games, some use a virtual location as well as the real location in a funny interactive way

This set of multimedia applications should be foreseen for the Release 5 and the future releases.

Service Examples

All these service examples could use or be enhanced by PSS.

Infotainment

Video on demand, including TV

Audio on demand, including news, music, etc

Multimedia Travel Guide

Karaoke – song words change colour to indicate when to sing

Multimedia information services:

- Sports
- News
- Stock quotes
- Traffic

Weather cams – gives information on other part of country or the world

Edutainment

Distance learning – video stream of teacher or learning material together with teacher’s voice or audio track.

How to ? service – manufacturers show how to program the VCR at home

Corporate

Field engineering information – junior engineer gets access to on line manuals to show how to repair the central heating system

Surveillance of business premises or private property (real-time and non real-time)

M-commerce

Multimedia Cinema ticketing application

On line shopping – product presentations could be streamed to the user and then the user could buy on line.

Annex B (informative): Change history

V.0.1.0	May 2001	First Draft (Presented at TSG-SA-WG1 #12)
v.0.2.0	July 2001	Second Draft (Presented at TSG-SA-WG1 #13)
v.0.3.0	November 2001	Third Draft (Presented at TSG-SA-WG1 #14)
1.0.0	November 2001	Raised to version 1.0.0 for presentation to SA #14
2.0.0	February 2002	Updated, ready for approval in SA #15
5.0.0	March 2002	Approved, SA#15

Change history												
TSG SA#	SA Doc.	SA1 Doc	Spec	CR	Rev	Rel	Cat	Subject/Comment	Old	New	WI	
SP-17	SP-020563	S1-021791	22.233	001		Rel-6	B	Requirement for efficient use of transport resources for PS Streaming	5.0.0	6.0.0	PSS-E	
SP-17	SP-020563	S1-021627	22.233	002		Rel-6	B	CR, PSS server file format	5.0.0	6.0.0	PSS-E	
SP-18	SP-020662	S1-022037	22.233	003		Rel-6	B	CR on streaming metrics	6.0.0	6.1.0	PSS	
SP-18	SP-020662	S1-022335	22.233	004		Rel-6	B	DRM requirement for streaming	6.0.0	6.1.0	PSS-E	
SP-18	SP-020662	S1-022337	22.233	005		Rel-6	B	Interaction MSS/PSS	6.0.0	6.1.0	PSS	
SP-18	SP-020662	S1-022353	22.233	006		Rel-6	B	Asset Information in File Format	6.0.0	6.1.0	PSS	
SP-18	SP-020662	S1-022354	22.233	007		Rel-6	B	Clarification of Transport Requirements	6.0.0	6.1.0	PSS	
SP-18	SP-020662	S1-022355	22.233	008		Rel-6	B	CR on 22.233 'PSS Charging'	6.0.0	6.1.0	PSS	
SP-18	SP-020662	S1-022327	22.233	009		Rel-6	B	CR FOR R6 22.233 on Declaration of Content Cache	6.0.0	6.1.0	PSS-E	
SP-19	SP-030029	S1-030245	22.233	010	-	Rel-6	B	PSS charging information	6.1.0	6.2.0	PSSrel6	
SP-21	SP-030466	S1-030962	22.233	011	-	Rel-6	C	Removal of content cache information in PSS architecture	6.2.0	6.3.0	PSS	
SP-21	SP-030466	S1-030963	22.233	012	-	Rel-6	C	Reliable delivery mechanism	6.2.0	6.3.0	PSS	
SP-32	-	-	22.233	-	-	-	-	Raised to version 7.0.0 as a result of implementing CR 30, a Rel-8 CR to a Rel-6 version.	6.3.0	7.0.0	-	
SP-32	SP-060370	S1-060627	22.233	0030	1	Rel-8	B	Requirement of avoiding live PSS interoperability problems among encoders and servers	7.0.0	8.0.0	TEI8	
SP-43	SP-090218	S1-090323	22.233	0032	1	Rel-8	F	Addition of Rel-8 mobile TV requirement to PSS	8.0.0	8.1.0	TEI8	
SP-46	-	-	-	-	-	-	-	Updated to Rel-9 by MCC	8.1.0	9.0.0		
SP-51	SP-110161	S1-110176	22.233	0033	-	Rel-9	F	Removal of the outdated reference to TS 21.133	9.0.0	9.1.0	TEI9	
2011-03	-	-	-	-	-	-	-	Update to Rel-10 version (MCC)	9.1.0	10.0.0		
2012-09	-	-	-	-	-	-	-	Updated to Rel-11 by MCC	10.0.0	11.0.0		