Source: ETSI TC-SMG

Reference: DE/SMG-061200P

ICS: 33.060.50

Key words: Digital cellular telecommunications system, Global System for Mobile Communications (GSM)



**Digital cellular telecommunications system (Phase 2);
Network Management (NM);
Part 1: Objectives and structure of Network Management
(GSM 12.00)**

ETSI

European Telecommunications Standards Institute

ETSI Secretariat

Postal address: F-06921 Sophia Antipolis CEDEX - FRANCE

Office address: 650 Route des Lucioles - Sophia Antipolis - Valbonne - FRANCE

X.400: c=fr, a=atlas, p=etsi, s=secretariat - **Internet:** secretariat@etsi.fr

Tel.: +33 92 94 42 00 - Fax: +33 93 65 47 16

Copyright Notification: No part may be reproduced except as authorized by written permission. The copyright and the foregoing restriction extend to reproduction in all media.

© European Telecommunications Standards Institute 1996. All rights reserved.

Contents

Foreword.....	7
Introduction.....	7
1 Scope.....	9
1.1 Normative references	10
1.2 Definitions and abbreviations.....	13
2 Objectives of Operations, Administration & Maintenance (OAM) of a PLMN	16
2.1 PLMN requirements for Network Management.....	16
2.1.1 Standardized OAM functionality	16
2.1.2 Inter-Network operation.....	17
2.1.3 Quality of Service.....	17
2.2 Targets of the OAM of a PLMN	17
2.3 The service and business areas of a PLMN.....	18
2.3.1 Administration of subscribers	18
2.3.2 Billing	18
2.3.3 Inter-operator accounting	19
2.3.4 Maximising revenue from PLMN resources	19
2.3.5 Customer services	19
2.4 The maintenance area of a PLMN	19
2.4.1 Alarms.....	20
2.4.2 Operating trends.....	20
2.4.3 Customer complaints	20
2.4.4 Software maintenance.....	20
2.4.5 Maintenance requirements.....	20
2.5 Other aspects of the OAM of a PLMN	21
3 The Application of TMN concepts to the PLMN.....	22
3.1 TMN concept of ETSI and CCITT.....	22
3.1.1 TMN architecture	25
3.1.2 Functional components of the TMN	25
3.1.2.1 Operations Systems Functions (OSF)	25
3.1.2.2 Reference points.....	26
3.1.2.3 Data Communication Function (DCF).....	26
3.1.2.4 Mediation Function (MF).....	26
3.1.2.5 Network Element Functions (NEFs).....	27
3.1.2.6 Q Adaptor Functions (QAF)	27
3.1.2.7 Work Station Functions (WSFs).....	27
3.1.3 TMN standard interfaces.....	27
3.1.3.1 Specifying Interfaces	28
3.1.3.2 Shared Management Knowledge (SMK)	30
3.2 PLMN Network Management Implementation	31
4 The PLMN TMN Information Model	32
4.1 Towards an Object-Based Management Information Model	32
4.1.1 Modelling techniques and guidelines.....	32
4.1.2 Key definitions.....	32
4.1.2.1 Resource	32
4.1.2.2 Object and Managed Object.....	32
4.1.2.3 Hierarchies	33
4.1.3 Objectives of modelling.....	33
4.1.4 Benefits and limitations of O-O Modelling.....	34
4.1.4.1 Benefits	34

	4.1.4.2	Limitations	34
	4.1.4.3	Constraints	35
	4.1.4.4	Support of variants	35
	4.1.5	Providing different views	35
	4.1.6	Added value functions	36
	4.1.7	Logically Layered Model	37
	4.1.8	Some main difficulties of total management	38
4.2		Methodology towards an Information Model	39
	4.2.1	Top down	39
	4.2.2	Bottom up	39
	4.2.3	A pragmatic approach	41
	4.2.4	Information model registration	42
	4.2.4.1	The ETSI sub-tree	42
	4.2.4.2	Information Model Identifiers	43
4.3		Information Models	43
	4.3.1	Types of Information Models	43
	4.3.2	High level object model containment	44
	4.3.2.1	Perspectives	44
	4.3.2.2	Model structure and content	45
	4.3.2.3	Network level object classes	45
	4.3.2.4	Other generic MOCs	46
	4.3.2.5	GSM specific MOCs	46
	4.3.2.6	Management of signalling systems	47
	4.3.2.7	Instantiation example	47
5		Introduction to the GSM Operations, Administration and Maintenance ETSS	48
	5.1	PLMN Management Functional Areas	48
	5.1.1	Administration and commercial	48
	5.1.2	Security	48
	5.1.3	Operations and performance	48
	5.1.4	Change	49
	5.1.5	Maintenance	49
	5.2	Management services	50
	5.3	Management Service Components	52
	5.4	Structure of the GSM 12-Series	52
	5.4.1	General specifications	52
	5.4.2	Network Management Functions	53
	5.4.3	TMN interface specifications	55
		Annex A (normative): GDMO definitions for GSM-Specific High Level Managed Objects	58
A.1		Managed Object Classes	58
	A.1.1	aucFunction	58
	A.1.2	bssFunction	58
	A.1.3	callRecordingFunction	59
	A.1.4	eirFunction	59
	A.1.5	hlrFunction	59
	A.1.6	mscFunction	60
	A.1.7	plmnNetwork	61
	A.1.8	smsGIWFunction	61
	A.1.9	vrFunction	63
A.2		Package definitions	64
A.3		ATTRIBUTE DEFINITIONS	64
	A.3.1	aucFunctionId	64
	A.3.2	bssFunctionId	64
	A.3.3	setOfCc	64
	A.3.4	eirFunctionId	64
	A.3.5	eird	65

A.3.6	eirNumber.....	65
A.3.7	hlrFunctionId.....	65
A.3.8	listOfSupportedBS.....	65
A.3.9	listOfSupportedSS.....	67
A.3.10	mcc.....	67
A.3.11	mnc.....	67
A.3.12	mscFunctionId.....	67
A.3.13	mscld.....	69
A.3.14	mscNumber.....	69
A.3.15	setOfNdc.....	69
A.3.16	smsGIWFunctionId.....	69
A.3.17	vrFunctionId.....	71
A.3.18	vrld.....	71
A.3.19	vrNumber.....	71
A.4	Actions.....	71
A.5	Notifications.....	71
A.6	Parameters.....	71
A.7	NAME BINDINGS.....	72
A.7.1	managedElement-plmnNetwork NAME BINDING.....	72
A.7.2	hlrFunction-managedElement NAME BINDING.....	72
A.7.3	aucFunction-managedElement NAME BINDING.....	72
A.7.4	vrFunction-managedElement NAME BINDING.....	72
A.7.5	mscFunction-managedElement NAME BINDING.....	74
A.7.6	eirFunction-managedElement NAME BINDING.....	74
A.7.7	bssFunction-managedElement NAME BINDING.....	74
A.7.8	smsGIWFunction-managedElement NAME BINDING.....	74
A.8	SYNTAX DEFINITIONS.....	76
Annex B (normative):	Definition of Common Management Functions.....	78
B.1	Description of Common Management Services.....	78
B.1.1	Forwarding of Event Reports.....	78
B.1.2	Information Logging.....	78
B.1.3	Bulk Data Transfer between the OS and the NE.....	78
B.1.3.1	Transfer of data from the NE to the OS requested by the OS.....	79
B.1.3.2	Transfer of Data from the NE to the OS requested by the NE.....	79
B.1.3.3	Transfer of Data from the OS to the NE requested by the OS.....	79
B.1.3.4	Error conditions.....	80
B.2	GDMO definitions for Common Management Functions.....	82
B.2.1	MANAGED OBJECT CLASSES.....	82
B.2.1.1	simpleFileTransferControl.....	82
B.2.1.2	generalDataTransferControlFunction.....	82
B.2.1.3	Recommendation X.721: 1992 alarmRecord.....	82
B.2.1.4	Recommendation X.721: 1992 attributeValueChangeRecord.....	82
B.2.1.5	Recommendation X.721: 1992 eventForwardingDiscriminator.....	82
B.2.1.6	Recommendation X.721: 1992 log.....	82
B.2.1.7	Recommendation X.721: 1992 objectCreationRecord.....	82
B.2.1.8	Recommendation X.721: 1992 objectDeletionRecord.....	82
B.2.1.9	Recommendation X.721: 1992 stateChangeRecord.....	83
B.2.1.10	transferReadyRecord.....	83
B.2.1.11	bulkTransferErrorRecord.....	83
B.2.2	Package definitions.....	84
B.2.2.1	dataTransferUploadControlPackage.....	84
B.2.2.2	dataTransferDownloadControlPackage.....	84

B.2.2.3	generalDataTransferControlFunctionPackage.....	85
B.2.2.4	simpleFileTransferControlBasicPackage	85
B.2.2.5	transferNotificationArgPackage	85
B.2.2.6	bulkTransferErrorPackage.....	86
B.2.3	Attribute Definitions	87
B.2.3.1	generalDataTransferControlFunctionId.....	87
B.2.3.2	simpleFileTransferControlId.....	87
B.2.3.3	fileListValues.....	87
B.2.3.4	linkedTransferIdValue	87
B.2.3.5	transferIdValue	87
B.2.4	ACTIONS.....	89
B.2.4.1	requestTransferUp.....	89
B.2.4.2	transferUpReceived	89
B.2.4.3	requestTransferDown.....	89
B.2.4.4	transferDownComplete	90
B.2.5	NOTIFICATIONS.....	91
B.2.5.1	transferUpReady	91
B.2.5.2	bulkTransferError	91
B.2.5.3	transferDownReady	91
B.2.6	NAME BINDINGS	92
B.2.6.1	generalDataTransferControlFunction-managedElement	92
B.2.6.2	simplefileTransferControl-generalDataTransferControlFunction	92
B.2.7	SYNTAX DEFINITIONS	93
History		96

Foreword

This European Telecommunication Standard (ETS) was produced by the Special Mobile Group (SMG) Technical Committee of the European Telecommunications Standards Institute (ETSI).

This ETS provides the conceptual and methodological framework for the definition of a standardized approach to the management of a PLMN within the Digital cellular telecommunications system. This ETS corresponds to GSM technical specification, GSM 12.00, version 4.5.1 and is part 1 of a 3 part ETS as described below:

GSM 12.00 **ETS 300 612-1: "Digital cellular telecommunication system (Phase 2); Network Management (NM); Part 1: Objectives and structure of Network Management".**

GSM 12.01 ETS 300 612-2: "Digital cellular telecommunication system (Phase 2); Network Management (NM); Part 2: Common aspects of GSM Network Management".

GSM 12.07 ETS 300 612-3: "Digital cellular telecommunication system (Phase 2); Network Management (NM); Part 3: Operations and performance management".

NOTE: TC-SMG has produced documents which give technical specifications for the implementation of the Digital cellular telecommunications system. Historically, these documents have been identified as GSM Technical Specifications (GSM-TSs). These specifications may subsequently become I-ETSs (Phase 1), or European Telecommunication Standards (ETSs)(Phase 2), whilst others may become ETSI Technical Reports (ETRs). These ETSI-GSM Technical Specifications are, for editorial reasons, still referred to in this ETS.

Proposed transposition dates	
Date of adoption of this ETS:	06 June 1996
Date of latest announcement of this ETS (doa):	26 September 1996
Date of latest publication of new National Standard or endorsement of this ETS (dop/e):	27 March 1997
Date of withdrawal of any conflicting National Standard (dow):	27 March 1997

Introduction

The goals of implementing a Public Land Mobile Network (PLMN) and its continued effective operation, administration and maintenance are important issues. The creation of a system for the management of a PLMN, implemented according to the specification series 01 to 11 and the open, multi-vendor environment, demands a level of standardization of the inter-connectivity of the management components and their functionality. A system for Operation, Administration and Maintenance (OAM), using concepts of telecommunications management networks (TMN), potentially provides for a suitable degree of management integration in achieving these goals.

Approach

In order to achieve the above aim, the GSM 12 series of specifications has been devised, taking into account the following:

- GSM system philosophy, as given by the GSM 01 to 11 series of specifications, which define key functional areas.
- Relevant standardization work on network management and open systems management (as well as its realization, Telecommunications Management Network, TMN) already carried out by ISO, CCITT, ETSI etc.
- Existing operator and manufacturer experience in the management (i.e. operating, maintaining, administering) of telecommunication networks.

Accordingly, this ETS, and the other specifications of the 12-series, should adhere to the following guidelines:

- There should be internal consistency of the 12 series with the relevant system aspects given in 01 to 11 series Specifications, so that a commonly agreed view of the realization of a PLMN emerges.
- Avoidance of "re-writing" existing recommendations and specifications, but only referencing those applicable as far as possible. However, to ensure harmony with any such existing documents, some general items, such as definitions and figures may be reproduced within the 12 series if they are deemed important or helpful in establishing a common understanding.
- Analysis of current network management concepts and experience both with a top-down and bottom-up approach, so that a comprehensive and realistic management concept emerges.

1 Scope

This European Telecommunication Standard (ETS) provides the conceptual and methodological framework for the definition of a standardized approach to the management of a PLMN. (This framework is elaborated in the remainder of the 12-series specifications) It introduces concepts developed for the management of telecommunications networks by other standards groups, discusses their use in the context of the management of a PLMN, defines a complete context for PLMN management information and identifies the developments of other management models which can be beneficially employed in the global and integrated management of a PLMN.

This ETS also describes the methodology to be employed in the definition of the standardization activity and the scale of the results which are expected to be achieved.

PLMN management is described in terms of the objectives for the Operator enterprise. Relationships exist between network management functionality and functionality required to support the enterprise model. While the definition of the enterprise model is outside of the scope of this series of ETSs, an understanding of the requirements is necessary so as to provide the underlying network management procedures.

Field of application

The concept of the Telecommunications Management Network (TMN) has developed as the result of a demand for a common management approach to the management of the diversity of equipment types, functionality and service provision inherent in modern telecommunications networks. This diversity is also apparent in a PLMN and the adoption of the TMN concept can provide a common management methodology for:

- public and private networks (including mobile);
- transmission terminals;
- transmission systems;
- restoration systems;
- operations systems and their peripherals;
- digital and analogue exchanges;
- area networks;
- circuit and packet switched networks;
- signalling terminals and systems;
- bearer services and teleservices;
- software provided by or associated with telecommunications services;
- software applications;
- associated support systems;
- the TMN itself.

(For a comprehensive view of the field of application of the TMN, refer to CCITT Recommendation M.3010 [1])

By extension, the field of application includes radio base station systems and all other components of the PLMN.

Typically a PLMN is a telecommunications system consisting of several functional units necessary to perform mobile telecommunications services. These functional units include:

- Location Registers (LR);
 - Home Location Register(s) (HLR);
 - Visitor Location Register(s) (VLR);
- Mobile-services Switching Centre(s) (MSC);
- Base Station Systems (BSS);
- Mobile Stations (MS);
- Equipment Identity Register (EIR);
- Authentication Centre (AUC);
- Inter-working units;
- Transcoders;
- Transmission equipment;
- Echo Suppression equipment.

NOTE: several of the above mentioned functional units may be collocated or even be accommodated in the same physical implementation.

1.1 Normative references

This ETS incorporates by dated and undated reference, provisions from other publications. These normative references are cited at the appropriate places in the text and the publications are listed hereafter. For dated references, subsequent amendments to or revisions of any of these publications apply to this ETS only when incorporated in it by amendment or revision. For undated references the latest edition of the publication referred to applies.

- [1] CCITT Recommendation M.3010 (1992): "Principles for a Telecommunications Management Network (TMN)".
- [2] CCITT Recommendation X.701 (ISO IS 10040) (1992): "Information technology - Open Systems Interconnection - Systems Management Overview".
- [3] Draft ETR DTR/NA-043207: "Overview of Telecommunications Management Network (TMN) standards".
- [4] CCITT Recommendation X.200 (1992): " - Information technology - Open Systems Interconnection - Reference Model of Open Systems Interconnection for CCITT Applications".
- [5] CCITT Recommendation M.3020 (M.meth) (1992): "TMN Interface Specification Methodology".
- [6] CCITT Recommendation M.3200 (M.app) (1992): "TMN Management Services: Introduction".
- [7] CCITT Recommendation M.3400 (M.func) (1992): "TMN Management Functions".
- [8] CCITT Recommendation M.3100 (M.gnm) (1992): "Generic Network Information Model".
- [9] CCITT Recommendation X.720 (ISO 10165-1) (1992): "Information technology - Open Systems Interconnection - Structure of management information: System Management Information Model".
- [10] CCITT Recommendation X.721 (ISO 10165-2) (1992): "Information technology - Open Systems Interconnection - Structure of management information: Definition Of Management Information".

- [11] CCITT Recommendation X.722 (ISO 10165-4) (1992): "Information technology - Open Systems Interconnection - Structure of management information: Guidelines For The Definition Of Managed Objects".
- [12] CCITT Recommendation X.730 (ISO 10164-1) (1992): "Information technology - Open Systems Interconnection - Systems Management: Object management function".
- [13] CCITT Recommendation X.731 (ISO 10164-2) (1992): "Information technology - Open Systems Interconnection - Systems Management: State Management".
- [14] CCITT Recommendation X.732 (ISO 10164-3) (1992): "Information technology - Open Systems Interconnection - Systems Management: Attributes For Representing Relationships".
- [15] CCITT Recommendation X.733 (ISO 10164-4) (1992): "Information technology - Open Systems Interconnection - Systems Management: Alarm Reporting".
- [16] CCITT Recommendation X.734 (ISO 10164-5) (1992): "Information technology - Open Systems Interconnection - Systems Management: Event Report Management Function".
- [17] CCITT Recommendation X.735 (ISO 10164-6) (1992): "Information technology - Open Systems Interconnection - Systems Management: Log Control Function".
- [18] CCITT Recommendation X.736 (ISO 10164-7) (1992): "Information technology - Open Systems Interconnection - Systems Management: Security Alarm Reporting Function".
- [19] CCITT Recommendation X.740 (ISO 10164-8) (1992): "Information technology - Open Systems Interconnection - Systems Management: Security Audit Trail Function".
- [20] CCITT Recommendation X.741 (ISO DIS 10164-9): "Information technology - Open Systems Interconnection - Systems Management: Objects And Attributes For Access Control".
- [21] CCITT Recommendation X.742 (ISO CD 10164-10): "Information technology - Open Systems Interconnection - Systems Management: Accounting Meter Function".
- [22] CCITT Recommendation X.739 (ISO DIS 10164-11) (1994): "Information technology - Open Systems Interconnection - Systems Management: Workload Monitoring Function".
- [23] CCITT Recommendation X.745 (ISO DIS 10164-12) (1994): "Information technology - Open Systems Interconnection - Systems Management: Test Management Function".
- [24] CCITT Recommendation X.738 (ISO DIS 10164-13) (1994): "Information technology - Open Systems Interconnection - Systems Management: Summarization Function".
- [25] CCITT Recommendation E.800 (1988): "Quality of Service; Concepts, Models, Objectives, Dependability Planning".
- [26] GSM 02.08 (ETR 101): "Digital cellular telecommunication system (Phase 2); Quality of service".
- [27] GSM 03.05 (ETR 102): "Digital cellular telecommunication system (Phase 2); Technical performance objectives".

- [28] GSM 03.50 (ETS 300 540): "Digital cellular telecommunication system (Phase 2); Transmission planning aspects of the speech service in the GSM Public Land Mobile Network (PLMN) system".
- [29] GSM 05.05 (ETS 300 577): "Digital cellular telecommunication system (Phase 2); Radio transmission and reception".
- [30] GSM 06.32 (ETS 300 580-6): "Digital cellular telecommunication system (Phase 2); Voice Activity Detection (VAD)".
- [31] CCITT Recommendation X.724 (ISO DIS 10165-6): "Information technology - Open Systems Interconnection - Structure of management information: Requirements and guidelines for implementation conformance statement proformas associated with OSI management".
- [32] CCITT draft Recommendation Q.821: "Signalling system No. 7 management - Stage 2 and stage 3 description for the Q3 interface - Alarm Surveillance".
- [33] CCITT draft Recommendation Q.822: "Signalling system No. 7 management - Stage 1, stage 2 and stage 3 description for the Q3 interface -Performance Measurement".
- [34] ISO IS 9596-2: "Information Processing Systems - Open Systems Interconnection - Management Information Protocol Specification - Part 2: Common Management Information Protocol (CMIP)".
- [35] GSM 12.30 (ETR 128): "Digital cellular telecommunication system (Phase 2); ETSI object identifier tree; Common domain; Mobile domain Operation and Maintenance (O & M) managed object registration definition".
- [36] GSM 12.01 (ETS 300 612-2): "Digital cellular telecommunication system (Phase 2); Common aspects of GSM Network Management (NM)".
- [37] GSM 12.07 (ETS 300 612-3): "Digital cellular telecommunication system (Phase 2); Public Land Mobile Network (PLMN) Quality of Service".
- [38] GSM 12.02 (ETS 300 613): "Digital cellular telecommunication system (Phase 2); Subscriber, Mobile Equipment (ME) and services data administration".
- [39] GSM 12.03 (ETS 300 614): "Digital cellular telecommunication system (Phase 2); Security management".
- [40] GSM 12.04 (ETS 300 615): "Digital cellular telecommunication system (Phase 2); Performance data measurements".
- [41] GSM 12.05 (ETS 300 616): "Digital cellular telecommunication system (Phase 2); Subscriber related event and call data".
- [42] GSM 12.06 (ETS 300 617): "Digital cellular telecommunication system (Phase 2); GSM Network Configuration Management and Administration".
- [43] GSM 12.10 (ETS 300 618): "Digital cellular telecommunication system (Phase 2); Maintenance provisions for operational integrity of Mobile Stations (MS)".
- [44] GSM 12.11 (ETS 300 619): "Digital cellular telecommunication system (Phase 2); Fault Management of the Base Station System (BSS)".
- [45] GSM 12.13 (ETS 300 620): "Digital cellular telecommunication system (Phase 2); Maintenance of the Mobile-services Switching Centre (MSC)".

- [46] GSM 12.14 (ETS 300 621): "Digital cellular telecommunication system (Phase 2); Maintenance of location registers".
- [47] GSM 12.20 (ETS 300 622): "Digital cellular telecommunication system (Phase 2); Base Station System (BSS) Management Information".
- [48] GSM 12.21 (ETS 300 623): "Digital cellular telecommunication system (Phase 2); Network Management (NM) procedures and message on the A-bis interface".
- [49] GSM 12.22 (ETS 300 624): "Digital cellular telecommunication system (Phase 2); Interworking of GSM Network Management (NM) procedures and messages at the Base Station Controller (BSC)".

1.2 Definitions and abbreviations

Terminology is aligned with ETSI TCRTR 003 Vocabulary of terms for TMN

For the purposes of this ETS the following abbreviations apply.

ADC	Administration Centre
AOM	Application of Object Management
ASN.1	Abstract Syntax Notation (number) 1
AUC	Authentication Centre
bcf	base (station) control function
BSC	Base Station Controller
BSS	Base Station System
BTS	Base Transceiver Station
DCF	Data Communication Function
DCN	Data Communication Network
EIR	Equipment Identity Register
EWOS	European Workshop on Open Systems
GDMO	Guidelines for the Definition Of Managed Objects
HLR	Home Location Register
H/W	Hardware
IMEI	International Mobile station Equipment Identity
IMSI	International Mobile Subscriber Identity
ISDN	Integrated Services Digital Network
ISO	International Standards Organization
ISP	International Standard Profile

LLA	Logically Layered Architecture
LR	Location Register
MCF	Message Communication Function
MD	Mediation Device
MF	Mediation Function
MOCS	Managed Object Conformance Statement
MS	Mobile Station
MSC	Mobile-services Switching Centre
NE	Network Element
NEF	Network Element Function
NM	Network Management
NMC	Network Management Centre
NMF	OSI Network Management Forum
OAM	Operation, Administration and Maintenance
OMC	Operations and Maintenance Centre
O-O	Object-Oriented
OS	Operations System
OSF	Operations System Function
OSI	Open Systems Interconnection
pcm	pulse code modulation
PICS	Protocol Implementation Conformance Statement
PLMN	Public Land Mobile Network
QA	Q (Interface) - Adapter
QAF	Q - Adapter Function
QOS	Quality of Service
SMK	Shared Management Knowledge
S/W	Software
TMN	Telecommunications Management Network
VLR	Visitor Location Register
WS	Work Station

WSF

Work Station Function

2 Objectives of Operations, Administration & Maintenance (OAM) of a PLMN

The OAM of a PLMN will require all aspects of the OAM of existing terrestrial telecommunications with extensions and enhancements to encompass the particular requirements of mobile telephony.

The management should provide all the capabilities necessary for the integration of all the activities involved in the operation of a mobile network. These activities can be described in terms of Business and Service criteria. These functions are distanced from the actual PLMN infrastructure, except for the local maintenance intervention on a network element. (See figure 2/12.00 for an example functional architecture.)

The objective of PLMN management is to integrate the spectrum of PLMN Operator activities to achieve coherent and seamless information exchange, support Quality of Service objectives and assist in achieving business objectives.

2.1 PLMN requirements for Network Management

The basic requirements for an integrated mobile communications system lead to the following general objectives for PLMN Management:

- Integrated operation of the elements of a PLMN using standardized functionality;
- Inter-PLMN operation of the mobile system;
- Information on the Quality of Service provided.

2.1.1 Standardized OAM functionality

If Operators wish to make use of the advantages in procurement of a standardized PLMN, there is also a need for standardization of OAM functions to allow proper inter-working of management for network elements from different manufacturers.

To restrict neither the Operator nor the manufacturer, the standardization provides a logically structured framework for the necessary functions with freedom for supplementary additions and room for particular expansions and future evolution. This can be achieved by a management system, defined by a logical concept with the goal of true implementation.

The 12-series of Specifications defines a functional architecture with immediate relevance to the management of a PLMN using a logically structured functional model. Standardization is introduced in those areas where it is felt to be appropriate (utilizing accepted techniques) with reference to the work of other TMN and Systems Management standardization groups.

Management functions can be classified in terms of their level of definition, to facilitate the objectives of GSM. These are described in the following paragraphs.

- a) Operational standardization:
Functions included here are those necessary to support inter-PLMN roaming and network inter-working with other PLMNs or other networks.
- b) Multi-vendor environment standardization:
If a PLMN Operator wishes to operate in a multi-vendor environment, management functions and interfaces should be standardized to allow common modes of operation. This may include performance data collection, message format standards, security methodologies and consistency of maintenance approach.
- c) PLMN management facilities:
Functional areas within the control of a PLMN Operator are recommended for standardization but particular Operator requirements will impinge on the extent of the possible definition.
- d) Specific PLMN management or national requirements:
These are considered to be outside of the scope of standardization.

It is therefore necessary to determine three immediate levels of optional implementation criteria for the management functions described and defined in this series of specifications:

- Mandatory: the implementation of the function shall accord with the definition to allow successful working and inter-working of the PLMN;
- Standard Option: implementation of the function is optional but, if implemented, the definition contained in the 12-series shall be employed;
- Optional: the feature is described but both the use of the feature and the implementation method are optional.

2.1.2 Inter-Network operation

Inter-Network operations include:

- operation between PLMNs (of the same type) with Operators in different countries;
- (inter-PLMN) operation between PLMN(s) (of the same type) with Operator(s) in the same country;
- operation (inter-working) with existing or future partner networks, e.g. ISDN, PSTN, PCN;
- the provision of facilities for necessary and/or desirable information exchange between PLMN Operators (e.g. charging and accounting information, statistical data, information for resolving customer's complaints, blacklisted IMEIs).

Functions identified as essential for international and inter-PLMN operation, therefore, will be mandatory for the GSM network management system. Desirable functions will be optional in use but are included in the system definition.

The exchange of information related to service functionality may be subject to inter-Operator agreement and is outside of the scope of this series of specifications.

2.1.3 Quality of Service

The service expectations of GSM are described in various GSM ETSs and ETRs (see [26] to [30]). This subclause concentrates on the network Quality of Service philosophy as described in CCITT Recommendation. E.800 [25].

The PLMN Operator will be required to establish QoS criteria and objectives in the context of the service levels to be provided to customers and as expectations of the network infrastructure. It will be necessary to compare these with data gained by monitoring the performance of services, by customer complaints, or by monitoring the technical performance of the network in order to initiate improvements (e.g. by reconfiguration of resources or initiation of maintenance actions).

NOTE: The technical performance of the network can be monitored but does not necessarily reflect the service performance from the customer point of view. This applies particularly to mobile services as provided by the PLMN.

2.2 Targets of the OAM of a PLMN

The operations and maintenance system within the context of a TMN shall have the capabilities needed to allow a PLMN to be operated and maintained efficiently while providing service in accordance with a PLMN Operator's performance requirements.

Operations and maintenance directly impact upon the cost of owning and running the system. It is understood that these expenditures should not be greater than the comparable cost of existing systems.

In order to reduce total (lifetime) costs of a PLMN and to balance quality of service against operating and maintenance costs the network should have:

- an easy to enlarge hardware configuration (e.g. modules);

- a functionally structured software configuration which can be easily modified, if necessary, and provides for simple error detection;
- simple man-machine interfaces and a simple man-machine language for the OAM areas;
- the ability of controlling itself as far as possible; operations personnel should only have to supervise the reported events and reactions of the network;
- a low failure rate and/or immunity to faults (e.g. redundancy);
- simplified maintenance interventions and measures not requiring extensive training of maintenance personnel;
- rationalized spare parts and repair service, keeping down the cost of non-active equipment while achieving the quality required;

This target OAM environment will support the Quality of Service objectives across all of the network services provided by the PLMN Operator.

2.3 The service and business areas of a PLMN

Although the definition of the Service and Business functionality of the PLMN is not within the scope of the 12-series of specifications, there are potential interfaces which have to be considered between Service processes and functions and the PLMN management. As the prime objective of the network operator is to collect revenue from the services offered, these interfaces and their requirements cannot be ignored.

The service area, in conjunction with the business area, is concerned with five key aspects:

- a) the administration of subscribers;
- b) the collection of charges from subscribers;
- c) the collection of revenue from other operators;
- d) the maximisation of revenue from the network resources; and,
- e) provision of support to subscribers.

2.3.1 Administration of subscribers

Subscriber administration shall consist of an efficient means to:

- a) connect service for a subscriber;
- b) test such service including any features;
- c) upgrade services; and,
- d) discontinue service.

Connection of service can be a complex issue involving agents for the production and distribution of Subscriber Identity Module (SIM) cards, associated PIN numbers and other security checks. Integrated systems should be in place to allow services to be offered as soon as the subscriber requests it.

The service offered should be testable at the point of sale to ensure that the subscriber can use the service as soon as possible.

The subscriber should be able to enjoy new services when available without the need for the mobile station to be returned to the supplier for software change or upgrade.

It is possible that a subscriber may have service disconnected. This disconnection is a cost overhead which should be made efficiently while retaining the potential to re-establish service simply and easily.

2.3.2 Billing

The collection of revenue is imperative to the business. Therefore, recording mechanisms shall be considered as vital, in terms of logical and physical design. Billing record accuracy is paramount to this, with every record containing enough data to effectively bill the subscriber and minimise any potential error which can cause a discrepancy and non-payment of the bill.

2.3.3 Inter-operator accounting

Any portion of a call which is handled by a part of a PLMN may be charged for. Policies exist for accounting between operators but mechanisms are required to implement these policies. It is essential that Division of Revenue information is accurate and unambiguous to prevent any discrepancies in inter-operator charging.

2.3.4 Maximising revenue from PLMN resources

The PLMN consists of many and diverse resources. In order to maximise operational revenues, the utilization of such resources needs to be managed. It is this key area where the information from the network is passed to the business tools for analysis. The outcome of such analysis is that changes to the network configuration may be implemented. PLMN management plays a major part in providing the initial information and the services to implement those business requirements.

2.3.5 Customer services

The PLMN operator will need to provide support for the subscribers. This support may consist of:

- a) repair service;
- b) directory enquiries;
- c) billing information;
- d) the provision of new features;
- e) assistance in using the service;
- etc.

The ingenuity of the operator with customer service operations can act as both a generator of revenue and a market differentiator. In order to provide such services, the operator's organization should be able to be integrated with the core network to ensure seamless information transfer.

2.4 The maintenance area of a PLMN

Maintenance is the action necessary to maintain the required Quality of Service of the PLMN. Maintenance can either be reactive or pro-active. Pro-active maintenance will include routine maintenance activities. Reactive maintenance includes the activities undertaken to restore all or part of the network following a failure.

Other considerations may affect the maintenance policy of an operator. These will include any government regulatory requirements or customer guarantees and a declared Quality of Service.

The generation of pro-active maintenance - routine scheduling - will be based on the recommendations from the equipment suppliers aligned to the equipment environment, e.g. temperature, humidity, dust levels, usage. Effective routine maintenance should be scheduled in accordance with the requirements and not as a matter of course. It is important to ensure that any routine maintenance operation does not create operational problems, e.g. routine maintenance should not be carried out during the busy hour.

Reactive maintenance is triggered either by a failure message from the system (alarm), an alert generated by a variance in the operating trend, or a customer complaint.

The maintenance process should comprise:

- a) Monitor - Monitor the network for alarms or changes in operational trends.
- b) Detect - As soon as a failure occurs the failure should be detected and reported.
- c) Localise - The failure needs to be localised to instigate repair action.
- d) Rectify - The objective should be to rectify the cause of the failure and not just the effect.
- e) Restore - Service should be restored in the most cost effective way.
- f) Record - Details of the failure and the repair action should be recorded to assist in subsequent or similar failures.

2.4.1 Alarms

Alarms are unsolicited messages generated by network elements indicating a failure has occurred. A single unit may generate a number of different alarms which need to be filtered and analysed to determine the true cause of the failure.

2.4.2 Operating trends

In some circumstances, failures may occur where an alarm cannot be generated or the failure has caused a blocking of the alarm. Such alarm blocking can be compensated for by using management systems which require periodic "heart-beat" messages from critical systems. An alternative is to use management systems which monitor the trends of the service offered by the network, e.g. if a normally busy cell only carries a small percentage of its normal traffic it would be fair to assume that the cell has suffered a failure of some description, like an antenna system failure. This divergence from the normal trend may be converted into an alarm by the management system alerting network operating technicians. Sophisticated monitoring of systems may not be required as the records generated for each call or non-call related event can provide detailed information if there was a failure.

2.4.3 Customer complaints

Customer complaints can be defined as any event received from a customer who experiences dissatisfaction with the service which is not yet confirmed by the PLMN Operator as a network problem. As such dissatisfaction is subjective, the maintenance area can only convert the original customer complaint event into a fault event when the complaint is confirmed. This simplifies the relationship between the PLMN Operator's maintenance and the end user. Other complaint types, such as billing inaccuracies, are considered as network management problems but are not addressed in this subclause.

2.4.4 Software maintenance

It is estimated that 80% of the value of a PLMN is contained in the software of the network. Most systems which detect a failure attributed to a software problem tend to reset that process losing all data on the state of the system when the failure occurred. Software maintenance is no different to hardware maintenance. Failures have to be analysed to determine the criteria which lead to the failure. In hardware maintenance terms this would be equivalent to the localisation process. When the cause has been found then the repair can be implemented. After the repair, the system shall be able to be retested using the scenario which caused the failure to prove that the repair was successful.

It is also important that a degree of regression testing is considered when proving the problem resolution and the effect that it may have on the rest of the operational software.

2.4.5 Maintenance requirements

The maintenance requirements are based on the need to maintain a complex network of interconnected infrastructure geographically dispersed over whole countries and, in some cases, across national boundaries. The goal should be to rectify all failures encountered on the maintainer's first visit. To achieve operational economics, the maintainer should be selected from a pool of maintainers matching the fault criteria to the skills and availability of the engineer.

Thus:

- the correct engineer should attend;
- the correct site; with
- the correct tools and testers; with
- the correct replacement units.

By using integrated systems, reported events and performance measurements can be correlated into providing precise localisation of any problems.

Network management systems could exchange information between PLMN Operators and interconnected licensed Operators which carry or pass PLMN traffic. Information issued should only be passed to relevant

Operators. Thus service difficulties which may be experienced by roamers into a visited PLMN should be passed to the customer services of the roamer's network Operator. Where mobile traffic is received from the fixed network, any complaints experienced by a fixed wire customer due to PLMN problems should be alerted, where feasible, to the fixed line network Operator.

This is particularly important on boundaries between networks to ensure ownership of the problem and thus a speedy restitution of inter-network problems.

Integrated systems provide assistance to network Operators when investigating problems. Network Operators should have integrated systems for receiving information about problems. This information can be passed to the customer services department of the PLMN Operator for handling customer complaints or queries. The information can also be used for correlating deviations in the PLMN's own operating trends. For example, time may be wasted analysing low incoming call traffic if the problem is that the source network has a problem and no traffic is being delivered.

2.5 Other aspects of the OAM of a PLMN

Certain aspects concerning operations, administration and maintenance of specific equipment will be the responsibility of subscribers, MS manufacturers, sales agents, service providers etc. Such aspects could be e.g.:

- a) supporting certain services and facilities in the MS;
- b) provision of terminal equipment in the MS;
- c) activities and provisions required for MS access to PLMNs;
- d) correct provision and management of IMEI.

NOTE: In some countries the PLMN Operator may act as a sales agent, etc.

Additionally, functionality will exist to support the administration of subscribers and subscriptions. This could be provided by means of an Administration Centre (ADC) which, while its definition may be outside of the scope of this specification series, could require an interface to the TMN. Any decision as to whether the ADC is considered to be an element inside or outside the TMN will depend on the particular implementation and will remain a decision of the PLMN Operator.

3 The Application of TMN concepts to the PLMN

The 12-series of Specifications looks at the requirements for the implementation of an integrated and comprehensive management for the PLMN leading to the successful operation, administration and maintenance of that network. In performing these tasks, it will be necessary to differentiate between those aspects which are related to the physical implementation and the logical definition required to satisfy the creation of a management information model and the standardization efforts.

3.1 TMN concept of ETSI and CCITT

Both ETSI and CCITT have defined the concept of a Telecommunications Management Network (TMN) [1, 3]; see figures 1/12.00, and 4/12.00 to 6/12.00. The use of TMN is foreseen to be a means to optimize the OAM organization, to provide various end-users with data for supervision, planning and traffic management purposes, to ensure a better control of the quality of the services, etc.

The current TMN concept contains a logical structure originating from data communication networks. It utilizes the object oriented paradigm and, more generally, adopts the OSI systems management framework as defined by ISO. For these reasons it is adopted as the basis for the definition of the management of the PLMN.

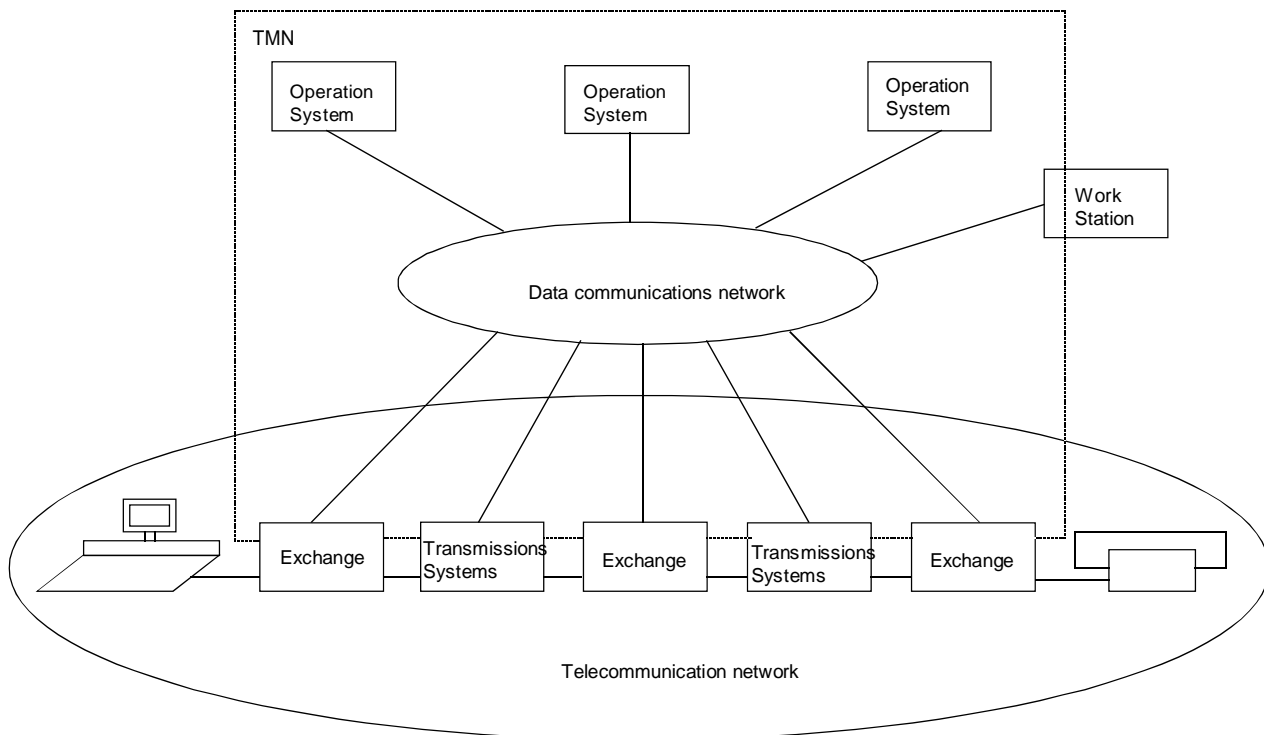

NOTE: The TMN boundary may extend to and manage customer/user services and equipment.

Figure 1/12.00 General relationship of a TMN to a Telecommunications Network (Figure 1/M3010 (reference subclause 3.1))

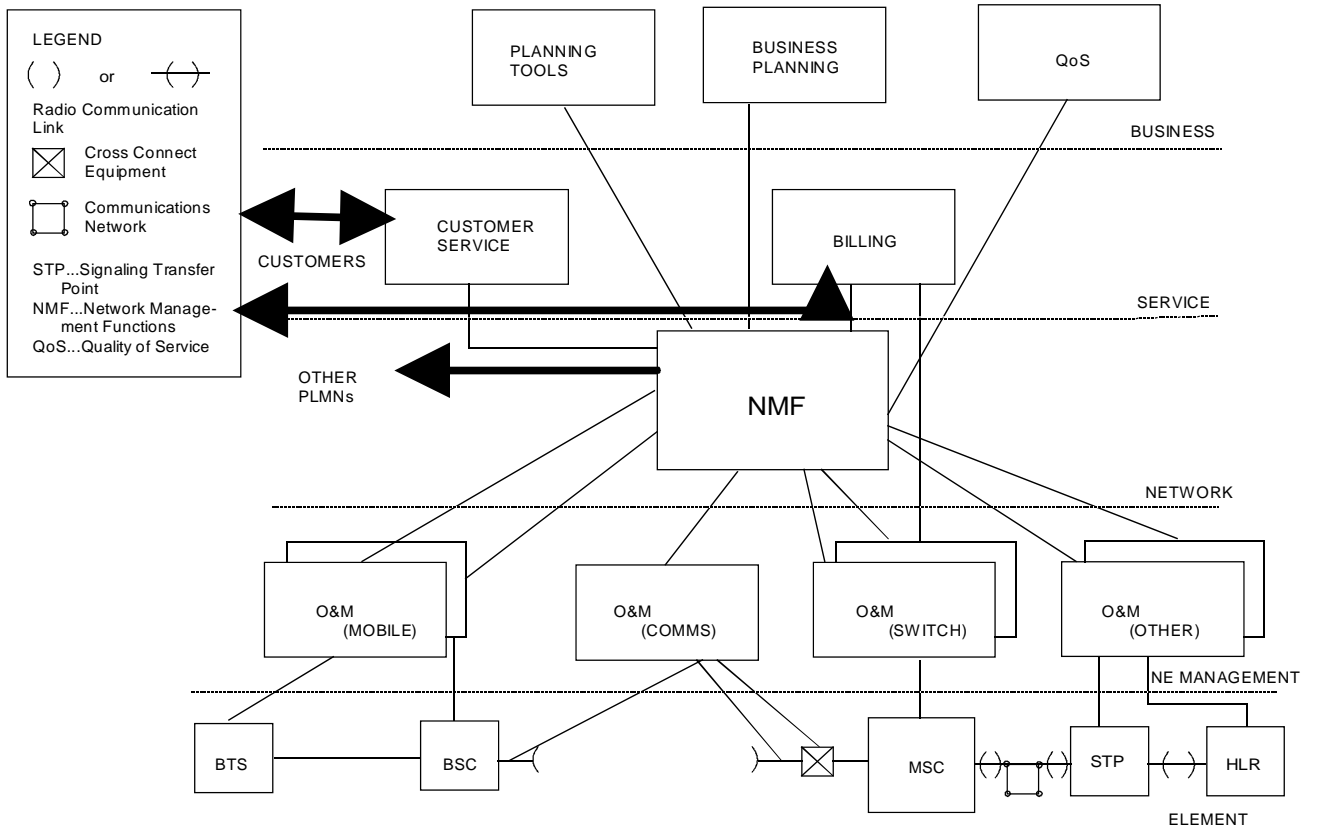

**Figure 2/12.00: Example PLMN TMN Functional Architecture model
 (reference subclauses 2, 4.1.7)**

NOTE: Figure 3/12.00 is for further study.

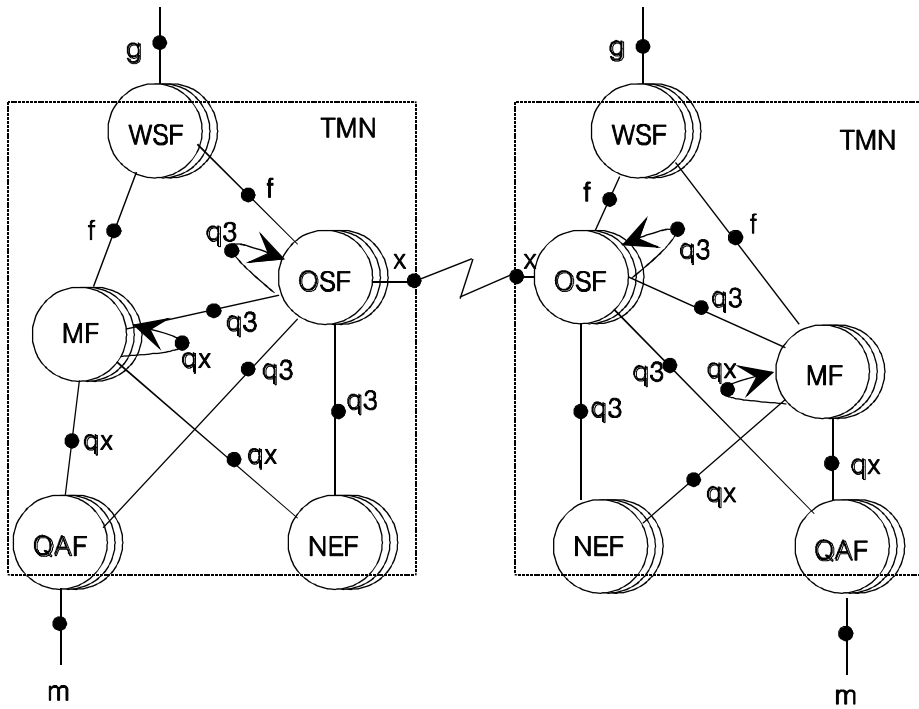
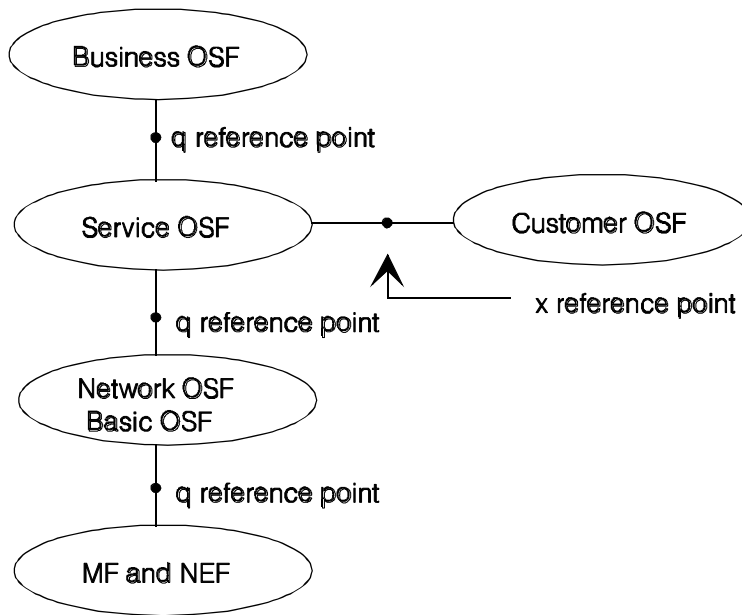

Figure 4/12.00: Illustration of Reference Points between Management Function Blocks (Figure 5/M.3010) (Reference subclause 3.1)



NOTE 1: Customer OSF is peer of Service OSF.

NOTE 2: Splitting of Network OSF and Basic OSF is an item for further study.

Figure 5/12.00: Example of an OS functional architecture (Figure 22/M.3010) (Reference subclause 3.1)

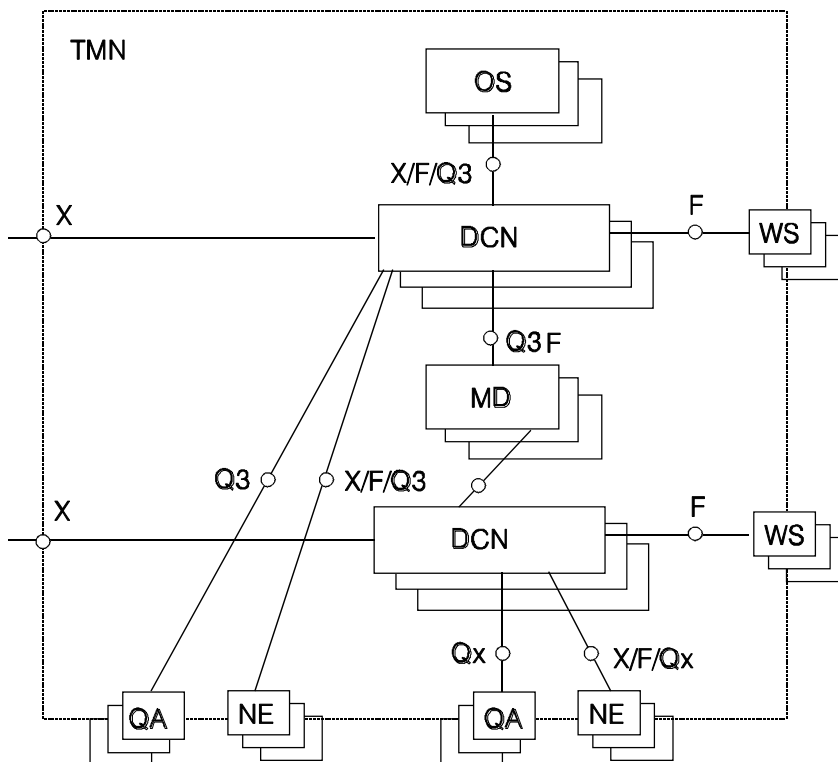

Figure 6/12.00: Additional Example of Interfaces for the TMN physical Architecture (Figure III-1/M.3010) (Reference subclause 3.1, 3.1.1)

3.1.1 TMN architecture

A TMN architecture shall provide a degree of flexibility to support various and varying network topologies. The TMN functional and reference models (see CCITT Recommendation M.3010 [1]) define the key components of a management solution. Additionally, some physical architecture examples are given as applications of the functional model (see figure 6/12.00 and GSM 12.01). The components of the functional architecture, described below, allow flexibility in design and a logical layering, if necessary.

3.1.2 Functional components of the TMN

The TMN models define a number of functional components which can be employed by the TMN designer. These can then be mapped onto physical TMN elements. The following paragraphs define the functional components.

3.1.2.1 Operations Systems Functions (OSF)

The Operations System Function (OSF) processes information related to telecommunications management for the purposes of monitoring, co-ordinating and/or controlling telecommunication functions, including management functions (i.e. the TMN itself).

The objects that are under the control of a given OSF are the components of the OSF management "domain".

On some occasions, the management information may be partitioned into layers that can be hierarchically organised. In such cases, different OSFs may be responsible for the different layers which represent their respective management domains. This type of arrangement is known as a "logically layered architecture" (see Subclause 4.1.7 of this ETS).

The physical implementation of OSFs (i.e. in an OS) provide the alternatives of either centralizing or distributing the general functions, which include:

- a) Support application programs;
- b) Database functions;
- c) User terminal support;
- d) Analysis programs;
- e) Data formatting and reporting;
- f) Analysis and decision support.

The OS functions may be distributed between a number of Operations Systems, depending on various criteria, e.g. network size, operational objectives. The distribution of OSFs is not considered suitable, by CCITT, for standardization in the short term.

3.1.2.2 Reference points

The relationships between components of TMN functions are defined using reference points. These allow identification of the boundaries between wholly self-contained functional units. The TMN definition (see CCITT Recommendation M.3010 [1]) identifies the following classes of reference points and the functional relationships to which they refer:

- q-class between OSF, QAF, MF and NEF;
- f-class for attachment to a WSF;
- x-class between OSFs of two TMNs or between the OSF of a TMN and the equivalent OSF-like functionality of another network.

When management functions are implemented remotely from one another, i.e. become material through the use of communications equipment, the reference point becomes implemented as an interface. For example, a q-class reference point, if realized, will become a Q-class interface.

3.1.2.3 Data Communication Function (DCF)

A Data Communication Function (DCF), implemented via a Data Communication Network (DCN), for a TMN should follow the reference model for open systems interconnection for CCITT applications (see CCITT Recommendation X.200 [4]).

The DCN may make use of different technologies (i.e. WAN, LAN, or MAN) and helps to connect the various TMN components with one another. The DCN is used when various functional groupings are implemented remotely from others. Each functional component will contain a message communication function (MCF) that will allow connection to the data communication function provided by the DCN.

3.1.2.4 Mediation Function (MF)

A mediation function (MF) is a function that primarily routes and/or acts on information passing between standardized interfaces. Mediation functions can be located on NE(s) and/or OS(s).

The processes that can form mediation can be classified into the following five general process categories:

- 1) Communication control;
- 2) Protocol and data conversion;
- 3) Communication (passing) of primitive functions;
- 4) Processes involving decision making;
- 5) Data storage.

3.1.2.5 Network Element Functions (NEFs)

Network Element Functions (NEFs) communicate with the TMN for the purpose of being monitored and/or controlled. The NEF provides the telecommunications and support functions which are required by the telecommunications network being managed.

The NEF includes the telecommunications functions which are the subject of management. These functions are not part of the TMN but are represented to the TMN by the NEF. The part of the NEF that provides this representation in support of the TMN is part of the TMN itself, whilst the telecommunication functions themselves are outside.

3.1.2.6 Q Adaptor Functions (QAF)

The Q-adaptor function (QAF) is used to connect, as part of the TMN, those non-TMN entities which are NEF-like and OSF-like. The responsibility of the QAF is to translate between a TMN reference point and a non-TMN (e.g. proprietary) reference point and hence this latter activity is shown outside the TMN.

3.1.2.7 Work Station Functions (WSFs)

A Work Station Function is defined as the functionality which provides interaction between O&M personnel and the OSFs (see CCITT Recommendation M.3010 [1]). However, it is not considered for standardization within this series of specifications.

3.1.3 TMN standard interfaces

The functional components are implemented through their device equivalents, the naming of which is dictated by the dominant functionality of the device, as follows:

OSF by Operations System (OS);
MF by Mediation Device (MD);
NEF by Network Element (NE);
WSF by Work Station (WS);
QAF by Q-Adaptor (QA).

TMN standard interfaces provide for the interconnection of NEs, OSs, MDs, QAs and WSs through the DCN. The goal of an interface specification is to ensure compatibility between interconnected devices to accomplish a given TMN application function independent of the type of device or supplier.

This requires compatible communication protocols and a compatible data representation method for the messages, including compatible generic message definitions for TMN application functions (see CCITT Recommendation M.3200 [6]). The management functions are related to each other.

An interface is essentially providing connectivity and interoperability mechanisms.

$$\begin{array}{l} \text{Interface} \\ \text{Specification} \end{array} = \begin{array}{l} \text{Communication Profile} \\ \text{Protocol Stack} \end{array} + \begin{array}{l} \text{Information Model} \\ \text{Message Set} \end{array}$$

The interoperability between two management systems (i.e. the manager - agent relationship) is obtained by the definition of a unique message set derived from an agreed information model and for an agreed management context. This is further discussed in subclauses 3.1.3.1 and 3.1.3.2. The methodology for defining an interface is further discussed in subclause 4.2.

The TMN model provides essentially two categories of interfaces:

- 1) Inner TMN interfaces belonging to the Q family of which Q3 is an OSI stack; and
- 2) Outer TMN interfaces such as X and F interfaces.

The X interface is used at the inter-TMN boundary or at the service user/provider to TMN interface. This interface is of special importance but its characteristics are for further study until the exact requirements are

better analysed/understood. Typically, it should be used to exchange billing and trouble ticketing information.

3.1.3.1 Specifying Interfaces

The process of defining an interface implies a number of steps and associated documents, as described in CCITT Recommendation. M.3020 [5], figure 9/12.00 and figure 10/12.00.

Specification Phase: Abstract Interface

During the specification phase, both a generic information model and the protocol machine of the protocol stack are defined respectively in a library of objects (e.g. in GSM 12.20) and in service and protocol documents (e.g. CMIP in ISO 9596 [34]). Typically such documents contain a number of options.

Conformance Specification: Concrete Interface

During this specification phase, a real, implementable ("concrete") interface is specified by defining which subset of the information model should be used and what options are retained for the protocol stack. The total definition of such subsets will be driven by the requirements detailed in GSM 12.02 to 12.11 (see clause 5) and is essentially in the province of the PLMN Operators. Consequently the GSM 12-series will have, as an objective, to maximise the extent of the definition of such subsets by maximising the number of mandatory elements in the object specifications.

The process of defining a concrete interface is one of selection and refinement. It comprises the identification of a subset of managed object classes, the elimination of options and the freezing of operator dependent choices from the abstract interface. This is documented in separate documents known as profiles, (e.g. ISPs for the protocol stack recommended in GSM 12.01 or EWOS AOM series for some objects). Conformance to these specifications is declared in implementation conformance statements, PICS expand for protocols and MOCS expand for managed objects.

As far as managed objects are concerned, the reduction of the number of options will be documented in Managed Object Conformance Statements (MOCS) according to the proforma defined in ISO 10165-6 [31]. These proformas may be prepared by ETSI or PLMN Operators and completed, i.e. transformed into real MOCS, by the manufacturers.

Conformance testing is normally achieved by executing test scripts, or test suites, that will demonstrate that a given product conforms to a given profile. The definition of such test suites is currently regarded as outside of the scope of the GSM 12-series.

Real Context: Interoperability

The real context is, in reality, the actual instantiation of the concrete interface model. There may be several different instantiations of a concrete interface due to the dynamic aspects of real systems.

Conformance does not guarantee interoperability. Interoperability is only possible when all ambiguities have been resolved and when the communicating systems have a common understanding of the management information. This is known as the Shared Management Knowledge and is discussed in the next subclause.

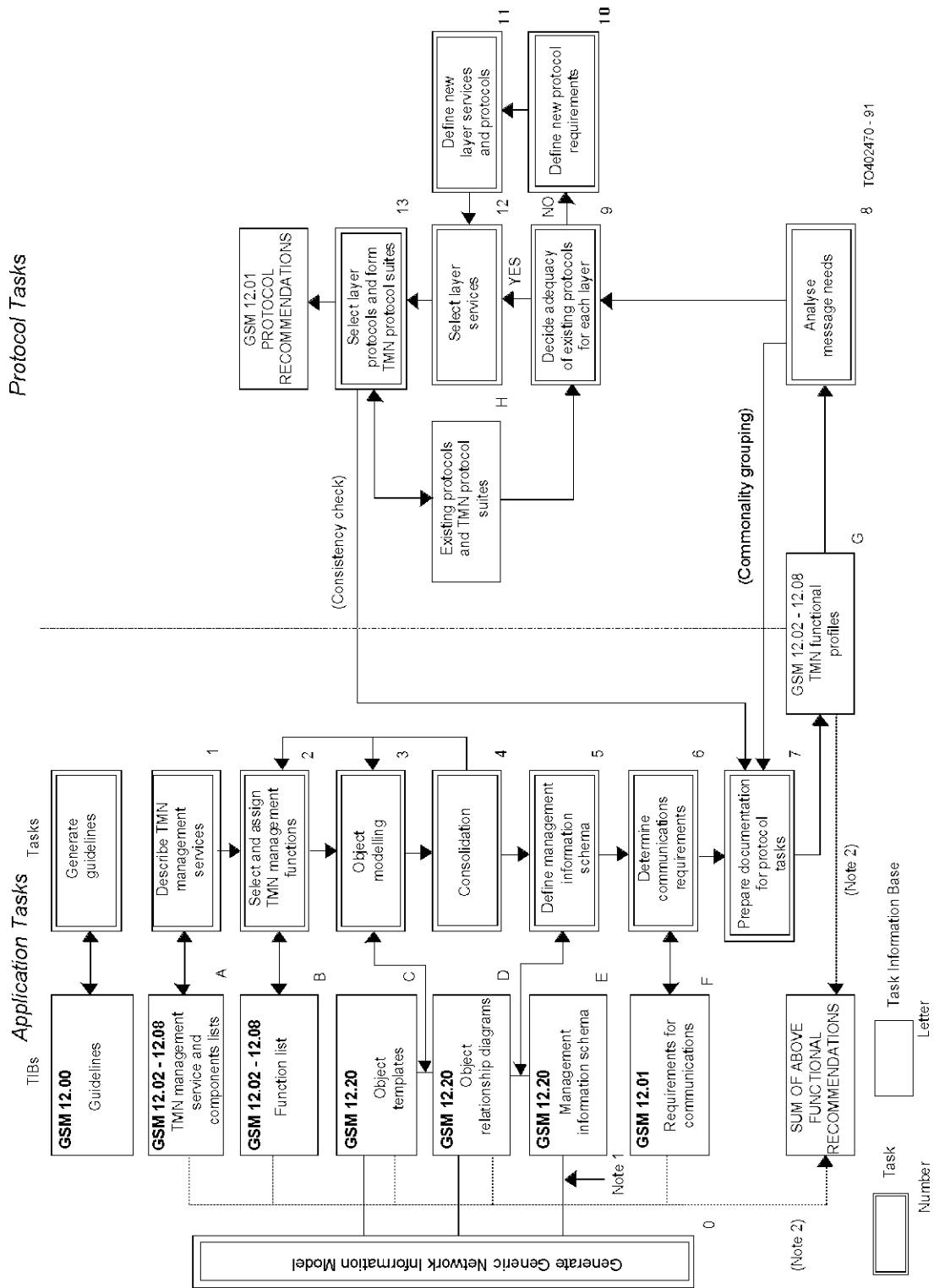

Figure 9/12.00: TMN Interface Specification Methodology (Figure 2/M.3020)
(Reference subclause 3.1.3.1, 4.2.1)

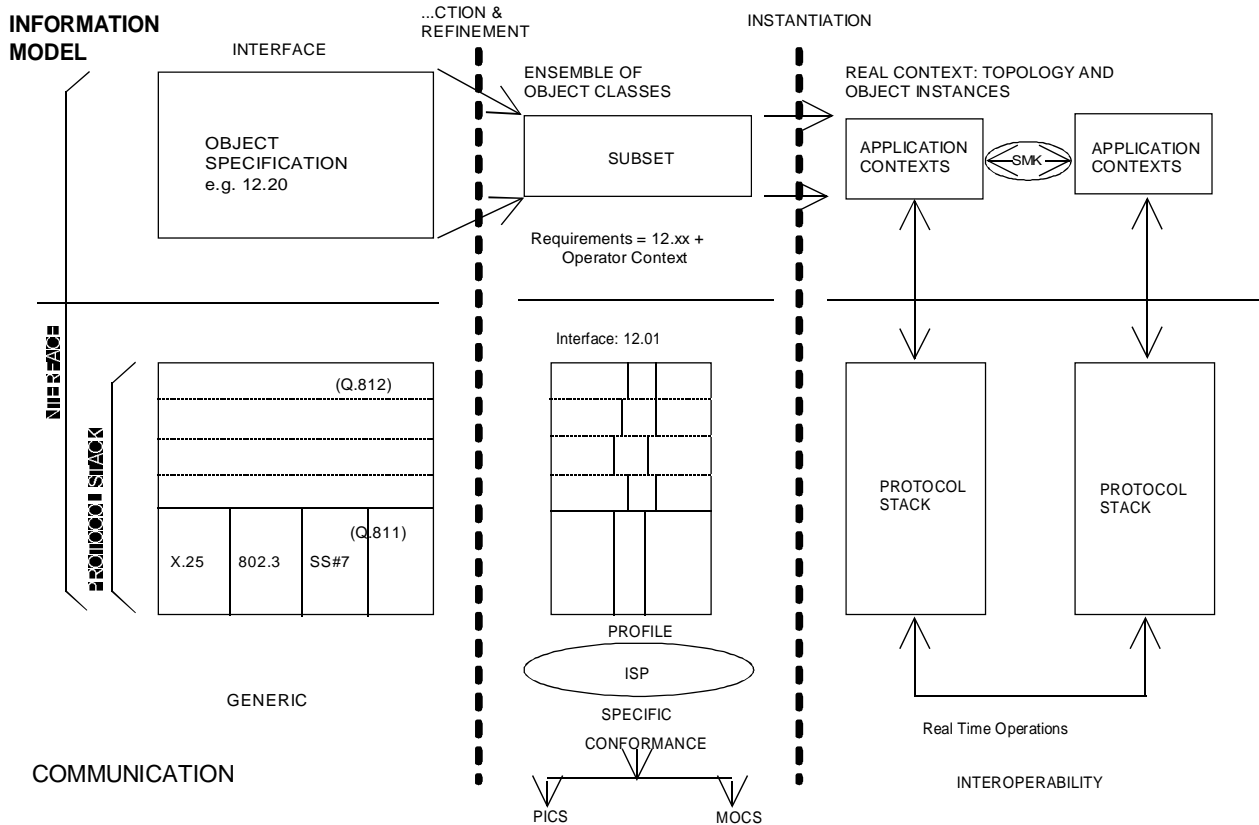

Figure 10/12.00: Relationship between conformance and interoperability (reference subclauses 3.1.3.1, 4.3.1)

3.1.3.2 Shared Management Knowledge (SMK)

The actual message set used at a given interface is the result of:

- a standardized information model, including:
 - object classes, naming relationships, etc.; and
 - which system may instantiate which classes, etc.;
- a given configuration or topology (which object instances have been created);
- a set of agreed restrictions (e.g. choice of options, limit in value ranges, reduced set of functional units, etc.);
- additional constraints like access control via password mechanisms or delineation of a certain management domain.

All these elements need to be agreed and understood by the systems (Manager/Agent) sitting on both sides of the interface. These are referred to as the "Shared Management Knowledge", or SMK. This SMK will initially be delivered in a static manner via bilateral agreements. Studies are ongoing regarding the possibility to support dynamic SMK (e.g. in ISO as part of the definition of the "Management Knowledge Management Function" in the 10164 series).

As defined previously, every ambiguity shall be resolved at the SMK level. This will include:

- PLMN Operator specific choices like additional behaviour, special object classes, special name bindings;
- vendor specific choices such as specific errors (e.g. processing failures);
- interface variants like which object classes are supported at which interface, what particular limitations exist at certain interfaces;
- specific object identifiers; and others.

This ETS suggests that the handling of a fully dynamic SMK (i.e. a SMK which is discovered, negotiated and modified after communication context - association - establishment) is for further study.

Initially the SMK information will be defined in a static manner, i.e. via off-line, bilateral agreements. The bilateral agreements will define what is the agreed management application context. Such a context will be unambiguously identified at association establishment between the two communicating systems. Any modification to these agreements will lead to a modification of the application context and should lead to the establishment of a new association.

NOTE: within this context, some dynamic aspects can be encompassed, like the creation and deletion of new object instances which may be reported via objectCreation or objectDeletion notifications, as described in ISO DIS 10165-2 [10].

3.2 PLMN Network Management Implementation

The following are guidelines for the implementation of a PLMN Management system. The detail will remain the responsibility of the PLMN Operator (see also GSM 12.01).

- 1) The PLMN management system should be as transparent as possible to the technology used in PLMN implementations.
- 2) The PLMN management system should be flexible enough to allow for evolution in PLMN functions and services.
- 3) The PLMN management system should be as modular as possible, so that irrespective of what network size will be reached or where the control/knowledge will reside, the PLMN management functionality can support all management aspects.
- 4) The PLMN management system should be fail-safe, i.e. neither equipment failure nor operator error should render it and/or the PLMN inoperative.
- 5) The PLMN management system should have no manufacturer dependencies, i.e. it should allow for the integration of equipment from different manufacturers in the same TMN, by using clearly defined inter-working.

In the PLMN, the Operations Systems and the associated management functions can be distributed among the physical entities so that vital functions are executed locally in the entities of the PLMN and non-vital in an Operations System (e.g. an OMC). Such an approach allows the PLMN to offer an un-managed service during the absence of the OS.

The distribution of logical functions to physical entities needs to take account of the requirement to offer a basic service in event of failure of some of the Operations Systems. This is a factor to be considered in the design of a specific TMN and is not considered further in this specification.

PLMN Network Elements require facilities to enable a set of functions to be performed through the use of on-site local access (or remote use of local access). The local functionality is not a subject for standardization in the 12-series specifications as these requirements are considered implementation dependent.

4 The PLMN TMN Information Model

This clause is divided into three subclauses which introduce modelling and the techniques to be employed in the definition of the PLMN information model. These comprise subclauses on:

- information modelling principles;
- the modelling methodologies to be adopted; and
- the purpose of information models and the PLMN model.

A description of management services and the method adopted for the inclusion of the detailed specification in the 12-series can be found in clause 5 of this ETS.

4.1 Towards an Object-Based Management Information Model

This subclause presents general principles about object oriented (O-O) modelling concepts that could be useful for the implementors that will develop the various models required to manage the GSM related infrastructure.

No attempt will be made to repeat nor even summarize the principles listed in all the relevant documents but reference will be made to some of the key aspects of TMN.

It is necessary to recall the object oriented paradigm. It consists of the modelling of some particular aspect of a given resource as an abstract representation called an object. An object typically contains both a functional and a data part. It relies on the principle of encapsulation, i.e. it only makes visible the external boundaries of an object while the implementation part is hidden. A set of messages are the only accessible things that allow an external entity, e.g. a manager, to cause the object to execute a function on the data it is supposed to support.

Another essential concept is the ability to extend the capabilities of a version of an object by refining it into a more specific and more efficient version. This activity is called inheritance.

4.1.1 Modelling techniques and guidelines

There is no intention to duplicate the work done by other ETSI, CCITT or ISO groups in terms of modelling guidelines. A series of views on the benefits and limitations as well as the difficulties and simplifications introduced by the use of OSI management concepts are presented.

A number of documents (framework and standards) are available that discuss the OSI management approach and discuss modelling guidelines (see CCITT Recommendation X.701 [2]). Written material and publications are available which describe O-O techniques, and a general methodology has been designed by CCITT/ETSI on how to globally approach the issue of telecommunications network management (CCITT M.3020 [5]). A brief overview of the principles is contained in Subclause 4.2.

4.1.2 Key definitions

Before going any further, it is necessary to define some key terms that will be used systematically in this series of specifications.

4.1.2.1 Resource

Any component or system that provides a "service" (in the more general sense) to a using "client". This includes both hardware and software components and may have different levels of complexity. Not all resources of a network are directly accessible by management functions. If they are, they will be qualified as manageable resources and are entitled to be modelled as managed objects.

4.1.2.2 Object and Managed Object

An object is a software abstraction that represents through an interface the functionality and activity of a resource. A managed object is a particular type that, through a management interface, only represents the manageable aspects of a resource. A managed object encapsulates management methods and data in the

sense that the object's management data is accessible only by invoking the object's management methods via the management interface.

NOTE: An object can represent a resource even though the resource is not currently offering its service to users or is not even installed (or created) yet.

4.1.2.3 Hierarchies

Object oriented modelling makes use of two essential object hierarchies which should not be confused:

- containment hierarchy primarily used for naming objects (see also ISO 10165-1 [9] and ISO 10040 [2]); and
- inheritance hierarchy primarily used for class specification (as further discussed later).

The example of an alarm record object depicted in figure 12/12.00 provides a comparison of the two structures.

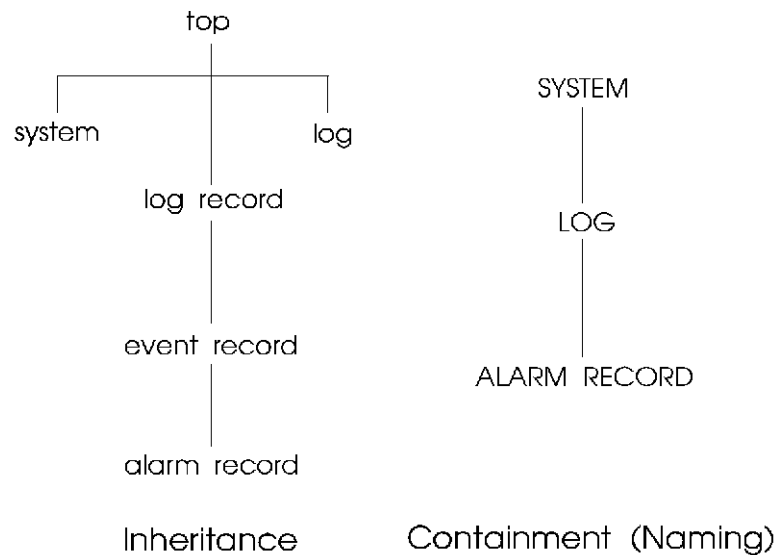

Figure 12/12.00: Example hierarchical object structures

4.1.3 Objectives of modelling

The objectives of modelling a network and its components, i.e. the resources involved in some telecommunications activity, are to provide an abstract representation of the management aspects of these resources. The resulting information model is composed of a set of managed objects that are linked by some relationships (containment, inheritance, functional, etc.).

This aspect of an object oriented information model is essentially dictated by the functional objectives. In this case the model will be influenced by management objectives. As these objectives may vary depending on a number of parameters, no single universal model can exist. Instead, a number of differing, albeit complementary, models may be inferred depending on the initial objectives of the modelling expert. One key objective which should be considered is the operator's (or management system user) activity related requirements.

The intention of the ETSI activities (reflected in the ETSI TMN methodology (see CCITT Recommendation M.3020 [5])) is to take an approach which is as generic as possible. The application of the modelling methodology will, nevertheless, be highly influenced by the dominant and initial objective (often configuration

management). Consequently, the design of a number of the initial objects will closely match the actual resources.

As new applications are considered, the initial objects might have to be refined or new objects will have to be modelled that will be less "hardware oriented" and more "software oriented".

It will also be possible to design value added functions in objects that build on top of the first series of objects in a sort of layered approach. This is discussed later in this clause.

4.1.4 Benefits and limitations of O-O Modelling

The object oriented (O-O) approach is a very promising one. It should not, however, be considered as the panacea that will fix all problems that a large management context (such as TMN) presents.

4.1.4.1 Benefits

The prime advantage of O-O techniques is the flexibility that is provided by the key aspects that have been identified earlier. The following are also advantages of the technique:

- Encapsulation: this allows to isolate the specification part from the implementation part. Access to an object is only through a well specified interface (accuracy) but this does not impose any other constraints on the implementors. In particular, if the designer has decided so, nothing would constrain the internal structure of an object unless the object is "open" and its internal structure revealed as further objects. This technique allows a staged specification and provides the freedom to stop specification at any desired level.
- Inheritance: a complementary aspect of the previous benefit is the ability to enhance an existing object by adding functionality or further specifying some details of its behaviour and characteristics. This again allows a progressive approach and a smooth transition, over time, from fairly generic concepts to more and more detailed (specific, vendor or operator dependant) aspects. The process of "refining" a generic object into a more specialised one can be used in many ways, e.g. either to add functionality to an object class (i.e. augment its characteristics - for example a modem with auto-answering features) or to further qualify a class by augmenting its attributes/parameter set (e.g. alarm record as a refinement of event record) or to further restrict the variant aspects of a class by limiting its set of options or reducing the range of acceptable values for a certain attribute (e.g. the selection of a subset of conditional attributes as mandatory).
- Recursivity: the approach is general enough to allow, with relative simplicity, recursive approaches. Two types of recursivity may be identified:
 - logically layered management architecture (discussed in subclause 4.1.7); and
 - management of the TMN itself where the TMN components can themselves be defined and managed as managed objects.

4.1.4.2 Limitations

Some limitations to the technique exist which need to be considered by the designer:

- the model cannot be refined forever: object size and complexity will impact implementations (efficiency, performance);
- cannot easily combine different views into a single object: actual resources are considered from different standpoints. Providing all these views in a single object may easily become complex. On the other hand, providing these views from different objects may not be easy as the interactions between these objects (that exist in the real resource) are not easy to reflect;
- the handling of inter-object relationships is not straight-forward: this has been mentioned in the case of multiple views of one object but it is also true of multiple objects reflecting the components of a larger resource (switch, network, BTS, etc.);

- modelling is an art, not a science: consequently, it is highly likely that the same set of resources will be modelled in different manners by independent experts. There is no single, ultimate information model for a given, moderately complex resource.

4.1.4.3 Constraints

As a consequence of the above mentioned limitations, a number of constraints are imposed by the systems that implement this approach. As these are essentially implementation details, these will not be discussed here. As an example, the designer will have to consider the benefit of defining many objects of a relatively small size compared to those of a limited number of huge objects.

Another type of constraint is the one that imposes on designers an extreme accuracy when defining the behaviour of objects. This essential requirement is not well understood and GDMO [11], which conveys both the semantic and syntactical aspects of the object specification, is still often confused with ASN.1 which represents only the syntactical part (messaging aspects).

The necessity for using a formal specification language will become crucial when implementors have detected the ambiguity of the plain English description of many behaviour clauses in GDMO. This is under study in ISO.

4.1.4.4 Support of variants

Although, in essence, standards should contain as few options as possible, it has been recognized that a basic requirement for the GSM 12-series is to accommodate operator and vendor specific aspects. The object oriented approach allows the support of variants in several ways:

- 1) **Inheritance:** vendors or operators can refine generic objects into specific objects.
- 2) **Conditional Packages:** conditional packages may be defined by standards or by vendors or operators. The use of these packages will have to be defined by additional specifications, e.g. in the managed object conformance statements (MOCS).
- 3) **Specific Information Fields:** In this scenario some attributes and parameters (e.g. notifications) may be defined as place holders for definitions contained in other documents. This technique makes use of the GDMO "PARAMETER" and ASN.1 "ANY DEFINED BY" constructs.

In all three cases the actual specification shall exist at the Shared Management Knowledge level (see subclause 3.1.3.2) and is identified by means of object identifiers (object class, package, parameter). Since these are operator or vendor specific variants it will be the responsibility of the specification body to allocate the object identifier, e.g. from a local or national registration authority.

4.1.5 Providing different views

One aspect of integrated management is that, depending on the application service, the same resource will have to be considered from different perspectives. Indeed, the TMN methodology has been specified to help designers to apprehend the reality from various perspectives called application services. This method allows to identify common management functions which, in turn, may be modelled as key building blocks.

With or without applying this methodology, different techniques are possible in O-O terms to provide the different views of the same resource:

- design the various aspects of the resource as a set of characteristics, behaviours, operations, notifications and attributes that may be packaged and incorporated in one single, large object; or
- design multiple objects, each of which represents a certain aspect of the resource (configuration, accounting, performance, etc.). The overall identity of the resource is modelled via a composite object that either encapsulates (contains) or points to (functional relationship object) the individual objects.

The choice between these approaches is a matter of trading off between the inherent complexity of large objects and the ability to provide data consistency in the case of multiple objects related to a composite object.

Some other aspects may be considered, like the ability to provide partial views of objects or limited access to certain users (e.g. based on user profiles) which will translate in either a screening or protection at object or attribute level.

4.1.6 Added value functions

When modelling resources from the configuration management perspective, it is highly likely that the resulting managed object classes will map fairly directly into the managed resources themselves. These managed objects can be considered as 'prime' or primitive objects.

Any value added function will be based on, and make use of, a set of these primitive objects.

The dependency or relationship between the value added functions and the primitive objects may be reflected (or described) in the following ways.

Encapsulation: In this case the value added service (itself modelled as an object) is using the primitive objects in an 'opaque' manner, i.e. the primitive objects do not need to be made visible as far as the value added service management is concerned. It is possible to design the value added service object as an encapsulation of the relevant primitive objects. See figure 14/12.00.

Functional Relationship: When there is a requirement to make both the value added service object and the relevant primitive objects visible to the manager, then functional relationships between the objects can be described. These functional relationships can be modelled by the use of relationship attributes as suggested in the ISO work on relationship modelling [14]. See Figure 15/12.00.

NOTE: It is not recommended to have backwards pointing attributes in the primitive objects as these objects may be involved in several such relationships. In such a case the primitive objects could become unmanageable.

The value added function may itself be modelled in a more complex manner (e.g. as a set of objects). The "logically-layered architecture" provides an example of this last scenario and this is discussed in subclause 4.1.7. (See also figure 16/12.00.)

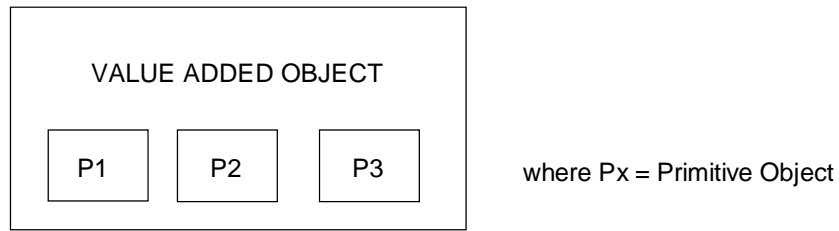

Fig 14/12.00 Encapsulation
 [Ref section 4.1.6]

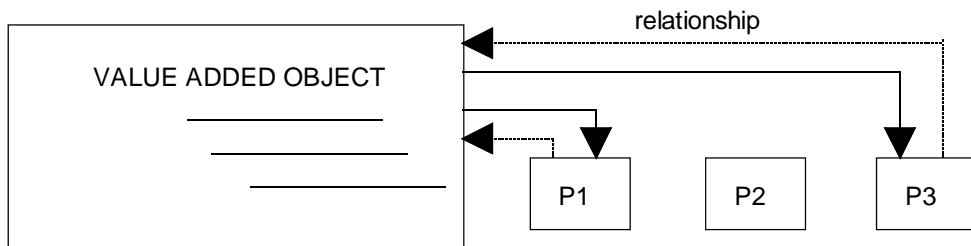

Fig 15/12.00 Functional Relationships
 [Ref section 4.1.6]

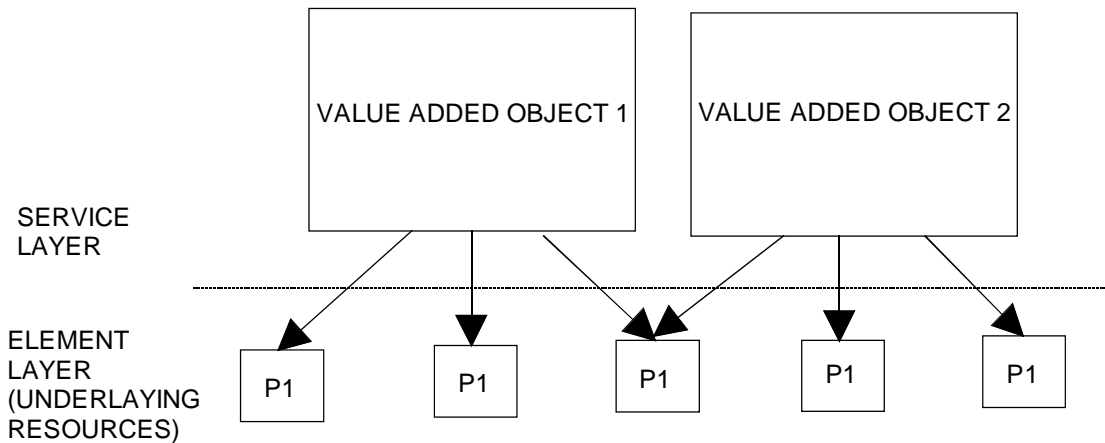

Figure 16/12.00: Layered Approach for Value Added Objects (Ref section 4.1.6)

4.1.7 Logically Layered Model

The TMN model, such as defined by CCITT Recommendation M.3010 [1], identifies a possible approach known as the Logically Layered Architecture (LLA). This model proposes to introduce and establish an hierarchical organization of the information. That is, it allows the functional partitioning of the OSF.

Typically, the objects of one layer offer a certain set of services and may themselves make use of the services of the next adjacent layer.

NOTE: The term "layer" used in the LLA should rather be replaced by the term "stratum" as the word layer has been heavily identified with other models such as the OSI layered model. In reality, the "layers" of an LLA have no relationship with the OSI layers with the possible exception that some managed objects designed to manage the OSI layers would probably be located at the Network Element Layer of a Logically Layered Architecture.

This layering of the information corresponds to management objectives and some proposals have been made for certain layers, e.g. a NETWORK layer is a layer that contains objects that have a network-wide scope, a SERVICE layer is a layer that contains objects that reflect the provisioning and maintenance of telecommunication services and an ELEMENT layer will typically contain objects representing Network Elements (see figure 2/12.00 for an example GSM layered approach).

A layer can be defined as a set of objects which collectively achieve common objectives. An upper layer (say of level N) will make use of lower layer object services (say level N-1). If and when this lower layer makes, in its turn, use of the next lower layer objects (say level N-2) this will not be visible to the upper layer (N).

Layering also allows to hide a certain set of objects as seen from non-adjacent layers; it makes them invisible. This can also be qualified as an opaque layer.

It can be inferred from the previous presentation that the essential characteristics of an information layer is that it achieves some semantic translation between the information available within the layer or at the lower boundary of a layer and the information available at the upper boundary.

Questions which are raised with the layered approach are:

- whether the model is totally opaque, i.e. one layer has access to the objects of one and only one lower layer (only one adjacent lower layer); and
- if a sort of bypassing feature is recognised that allows one layer to access (be adjacent to) more than one lower layer.

The case can be made that for some top level applications (e.g. billing/accounting) the top layer needs only to access the element level objects which are the actual source of accounting information. This would be done either in passthrough mode in a totally opaque model or with direct access to the lower layer in another type of model.

As the layering is essentially a policy issue, i.e. dependent on the operator's business and operations model, it does not seem correct to recommend one model or another. This should not affect the object modelling activities as the layered approach mainly relies on a global information schema (meta model) and on mechanisms which allow navigation between layers.

4.1.8 Some main difficulties of total management

A number of questions persist that are not actually inherent to the O-O techniques, but are rather due to the magnitude of the problem of managing telecommunications networks. These can be classified in two main categories:

- Network-wide integration of functions and data;

the integration of management information in a large scale distributed network implies major questions such as replication and integrity of data. When data are distributed, all classical questions such as synchronisation (concurrency) and consistency of the databases will need to be addressed.
- Inter-working between multiple and heterogeneous functional managers;

when two managing systems (manager-manager or manager-agent) communicate for the purpose of management they need to do it in a globally harmonised framework. They need to share a certain set of information without which the exchange of management protocol data units (MPDUs) would be inefficient or ineffective. The following points need special attention:

- Object naming;
- Sharing management knowledge;
 - static and dynamic aspects;
 - schema and class data (containment, inheritance);
 - instances (topology and names);
 - communication stacks;
- Data consistency and integrity;
- Real time update and flow of information.

Some other questions which are inherent to the O-O approach and generated by the magnitude of the problem exist at the modelling level. An uncoordinated activity could lead to a proliferation of objects and therefore induce additional difficulties in terms of registration, conflicts and redundancies

4.2 Methodology towards an Information Model

A number of external references are available to guide designers towards proper object models (ISO GDMO, CCITT M.3020, OSI/NMF guidelines, current literature about object modelling). The ISO/CCITT GDMO templates [11] shall be used to specify the managed objects. However, the way to get to these objects is not an easy matter.

Depending on the context and the understanding of the designer, various approaches may be taken as described below and in figure 8/12.00.

4.2.1 Top down

The CCITT M.3020 [5] proposes a very clear approach to define objects starting from management objectives, i.e. from management applications (called management services in M.3020). This approach basically proposes to decompose the management problem in itemised studies. Each study will decompose a particular management service into components with the aim of identifying "elementary functions" that will, in turn, be modelled as objects (see figure 8/12.00, figure 1 of M.3020).

The process is further decomposed into 13 steps as depicted in figure 9/12.00 (figure 2 of M.3020).

This approach is conceived as an iterative one as the intention is to reconcile the various functions and objects in order to maximise commonalities, i.e. to minimize the generated number of managed objects.

4.2.2 Bottom up

This approach is commonly used to derive, in a rapid manner, managed objects from managed resources. In this case, the results very often closely match the physical appearance of resources. If this method presents great merits in terms of delivery time of an object model it does not easily allow a refinement process and very often leads to over-complicated, monolithic objects and, consequently, conflicting or overlapping models.

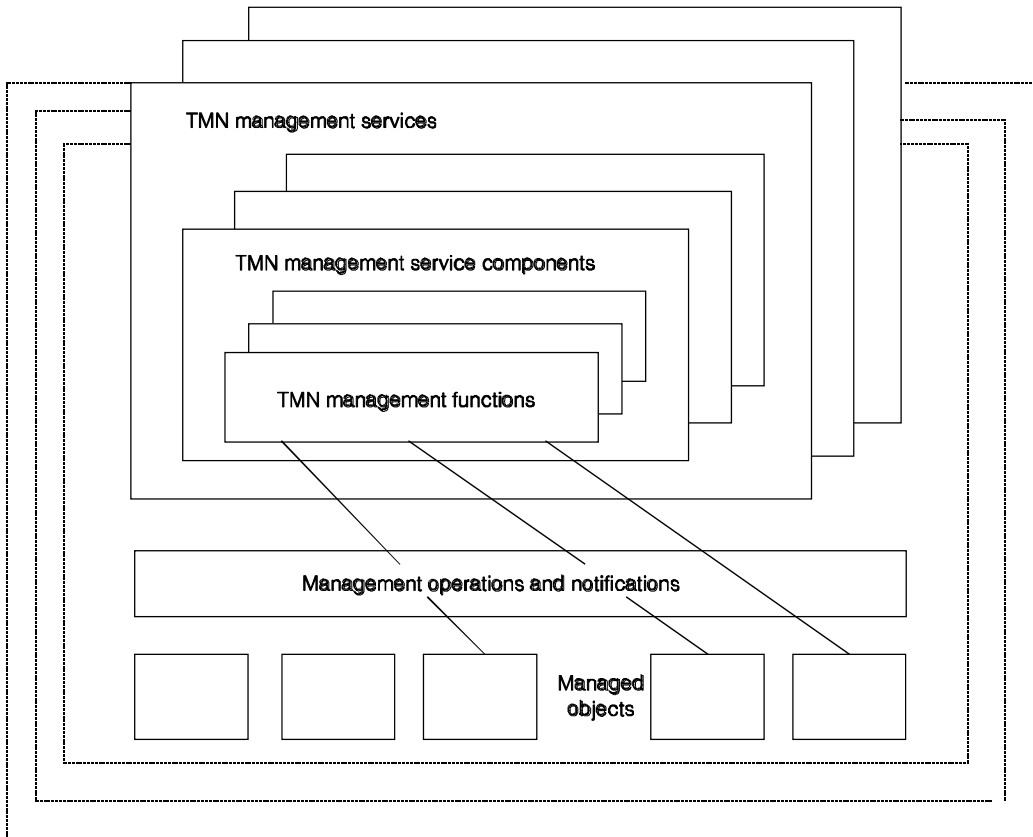

Example of TMN terminology

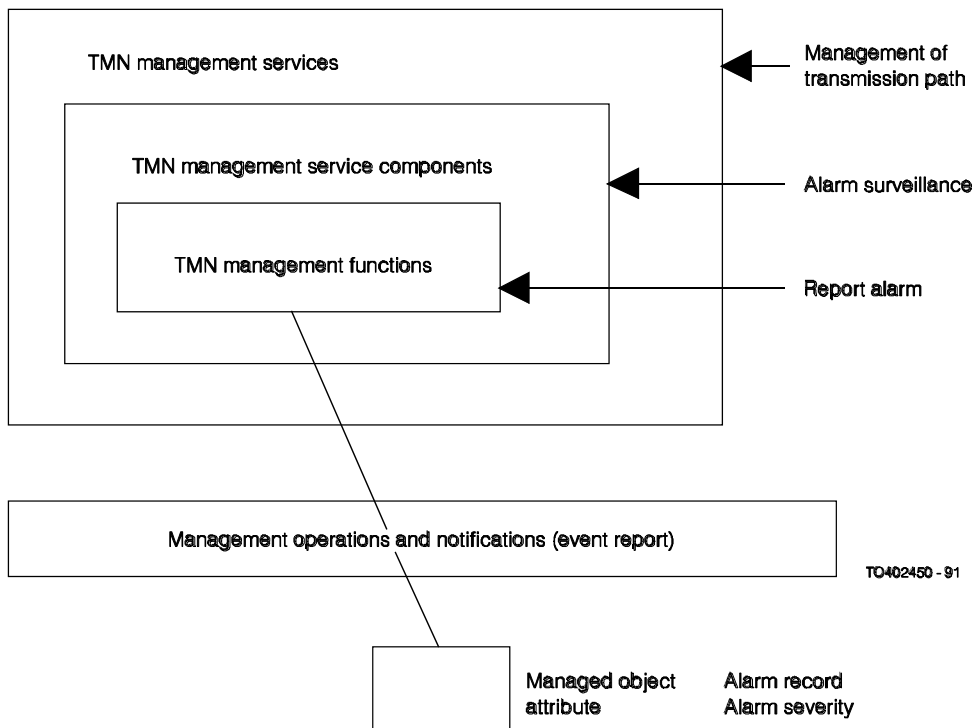
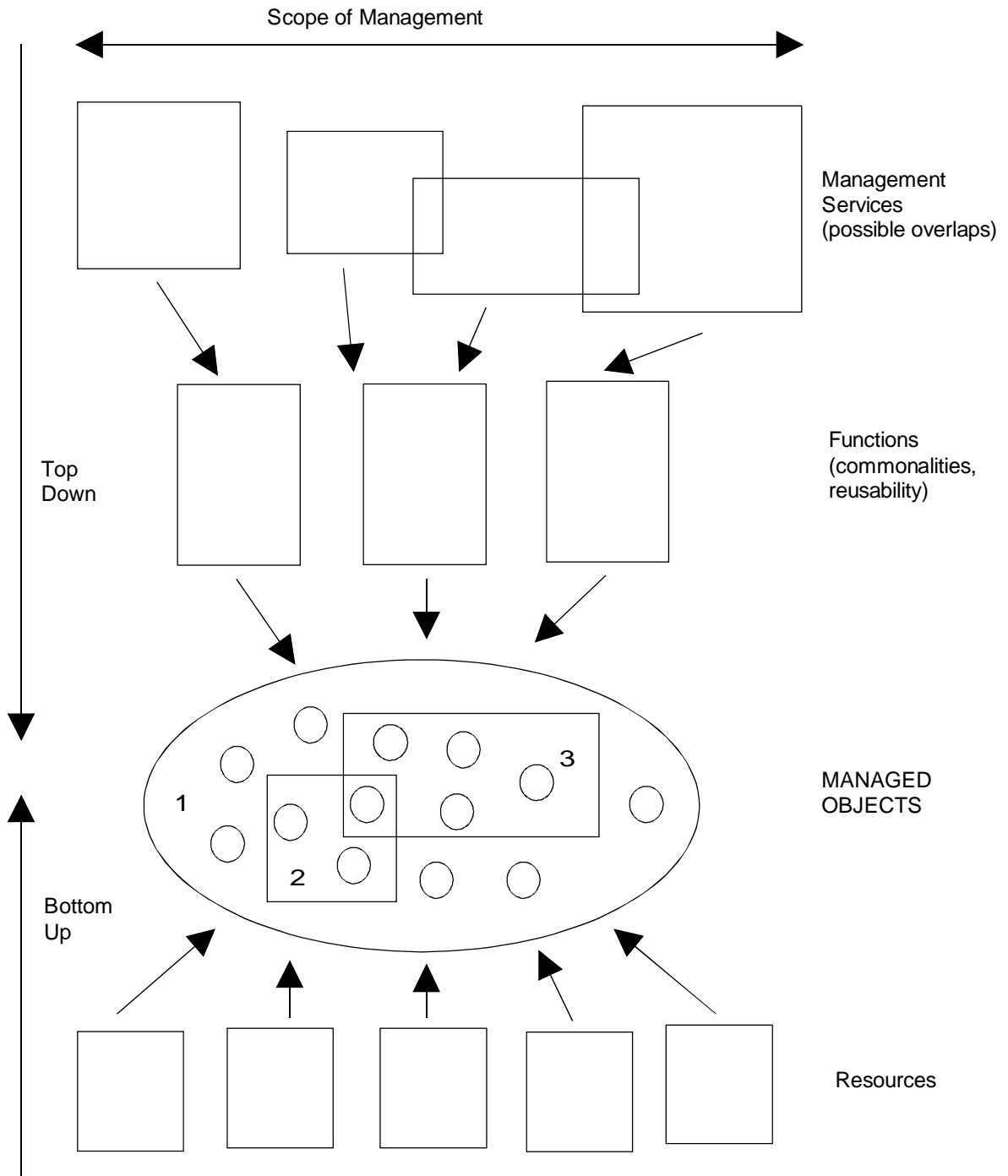

Figure 8/12.00: Decomposition of Management Services into Components and Functions (Figure 1/M.3020) (Reference subclause 4.2, 4.2.1)

4.2.3 A pragmatic approach

Although the top down approach offers a better chance to propose well integrated solutions, it is a lengthy process. It is therefore recommended to combine the top down and bottom up approaches in an iterative manner (see figure 11/12.00). This should allow to make use of the respective merits of both approaches.



1. Generic Information Model
2. One specific Information Model (per Q3)
3. Another specific Information Model (per Q3)

Figure 11/12.00: Information Modelling - Pragmatic Approach (Ref section 4.2.3)

The requirements are described in terms of Management Services within the PLMN management functional areas defined in specifications 12.02 to 12.11. The methodology for the specification of TMN interfaces can

utilise the methodology of CCITT M.3020 [5] as described above. (See also Clause 5 of this ETS for more information on Management Services and Management Service Components.)

The Management Services are broken down into TMN Management Service Components related to the PLMN Management Functional Areas and the Management Layers. A specification of the TMN Management Functions, which are used by the TMN Management Service Components, is necessary (Task 2 of M.3020). A useful list of functions may be found in CCITT M.3400 [7]. If the needs of a Management Service are not satisfied by these functions, a new one will be defined.

After completing Task 1 and Task 2 there will be available a Task Information Base (TIB) A and B containing the Management Service, the Management Service Component and Management Function lists, partially based on existing TIBs from CCITT and ETSI and partially using new items specifically for PLMN management.

The TMN Management Functions will, where applicable, also use the System Management Functions (SMF) as defined by the ISO 10164 series (CCITT X.730, etc.) [12] to [24].

Simultaneously, modelling of the resources begins. This process will be tailored by a perception of the management capability required of the resources being modelled. Any assumptions made by the modellers for a particular decision should be relayed to the group responsible for the equivalent top-down document. The iteration of matching the evolving model to the decomposition into a functional specification and vice-versa allows the two processes to harmonize their results and produce consistency within the 12-series.

The models will be defined using GDMO templates. They will describe managed object classes, packages, attributes, parameters, notifications, behaviours and the ASN.1 syntax definitions. Where applicable, generic definitions (see CCITT Recommendation M.3100 [8]) will be imported.

The initial emphasis of the modelling will be on those management services and/or resources which typify a PLMN, i.e. the BSS, performance measurements, subscriber and mobile equipment administration, and charging. Other services and resources will be modelled as and when appropriate.

The BSS management model is described in GSM 12.20 and 12.21; performance measurements are modelled in GSM 12.04; the subscriber and mobile equipment administration model is described in GSM 12.02; and the charging data and administration model is described in GSM 12.05. The top most levels of the management information model and the definitions of management functions common across management services or resource management are described in this ETS

4.2.4 Information model registration

As the various aspects of the information model for PLMN management are defined, they will need to be assigned unique identifiers and be registered in a central library. The structure to be used in the identification of the information model described by the GSM 12-series is described in GSM 12.30 [35]. The following subclauses give a brief overview.

4.2.4.1 The ETSI sub-tree

The ETSI sub-tree is located under the CCITT root and identified as follows:

ccitt (0) identified-organization (4) etsi (0).

Beneath this, there are common domains including a mobile-domain (0) which also contains a reserved identity for GSM-defined operations and maintenance models (3). The object models defined in the 12-series are identified below this branch by the GSM document identity, or part document identity, in which they are contained, e.g. 12.20 (20), etc. (Precise number allocation is defined in the ETR 128 [35].)

4.2.4.2 Information Model Identifiers

The following identifier values are to be adopted. These identifiers give identities (agreed and used in ETSI and CCITT) to the information model and its environment.

- (0) informationModel
 - (0) standardSpecificExtension
 - (1) functionalUnits
 - (2) asn1Module
 - (3) managedObjectClass
 - (4) package
 - (5) parameter
 - (6) nameBinding
 - (7) attribute
 - (8) attributeGroup
 - (9) action
 - (10) notification

- (1) protocolSupport
 - (0) applicationContext

- (2) managementApplicationSupport
 - (0) standardSpecificExtension
 - (1) functionalUnitPackage
 - (2) asn1Module.

Each element within the described section of the object definition will then be assigned a unique identifier.

For example, the name binding of transceiver with bts contained in GSM 12.20 would be identified as follows:

(0,4,0,0,3,20,0,6,x)

where x is the unique identifier of the name binding definition assigned in GSM 12.20.

4.3 Information Models

As indicated earlier, the management aspects of the PLMN resources are modelled as "managed objects". The set of managed objects and the way they are related to each other (inheritance, containment, etc.) compose an "information model".

4.3.1 Types of Information Models

Different types of information models can be identified (see figure 7/12.00):

- 1) Generic Management Model.
This model essentially gathers all the objects that are subject to standardization. The model is usually not totally implemented in any particular management system.

- 2) Specific Information Model.
An interface is composed of a protocol stack and an information model. For each identified interface a specific information model will have to be identified which can be seen essentially as a subset of the generic model. It can be inferred from this that there will be one object model per type of Network Element. This is an essential component of the shared management knowledge that the Manager and Agent sitting on either side of a Q3 interface will have to maintain. If any conformance statement has to be generated regarding a given interface it will have to address the information model as it is directing the set of messages exchanged at the interface. (See also figure 10/12.00)

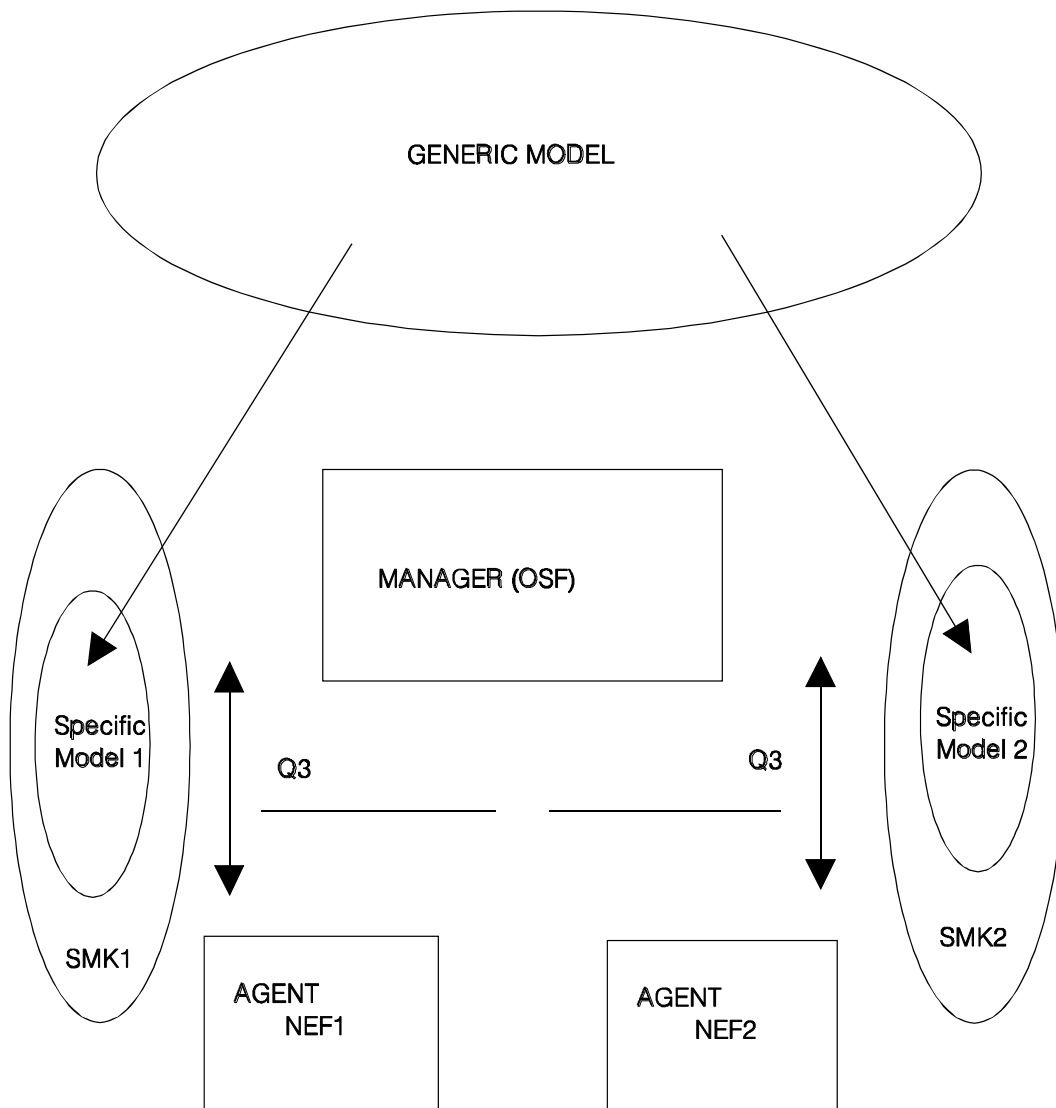

Figure 7/12.00 Example of one Manager handling different Agents (reference subclause 4.3.1)

4.3.2 High level object model containment

A PLMN, as stated previously, will comprise a range of telecommunications functionality besides that which is specific to GSM. All of this functionality will, to a greater or lesser extent, require to be managed either directly or indirectly by the PLMN Operator.

When designing a management model for a PLMN it is important to identify where and how information models for GSM specific functionalities relate to other telecommunications network management models under development in other ETSI, CCITT and ISO groups. This provides a means to incorporate the models defined by the 12-series specifications with those other management models in a coherent manner.

This objective can be achieved through an object model defining the highest level of the PLMN management information using generic and GSM-specific managed object classes for the management of telecommunications networks. The methodology for the modelling of a network and the generic managed object classes to be adopted can be found in CCITT Recommendation. M.3100 [8].

4.3.2.1 Perspectives

Management information modelling can include different management perspectives in the same managed object class definition. In the definition of PLMN specific management requirements, two perspectives have been found to be important. These are the modelling of the management of the specifically identified resources (e.g. the radio base station) and the management services which can be viewed as technology or network node independent (e.g. the recording of data concerned with mobile subscription activity).

It is one objective of the high level model to integrate these two perspectives into a single and coherent information model which will allow a high degree of integration of the management activities. At the same time, the model should also allow PLMN Operator flexibility to implement those aspects of the management information model which are of primary concern or are suitable to support the organizational requirements of the PLMN operation.

4.3.2.2 Model structure and content

The high level model takes as its basis the generic telecommunications management model proposed by CCITT in Recommendation M.3100. Figure 17/12.00 shows the containment tree with the generic object classes and the PLMN specific object classes. Each PLMN specific managed object class provides a "hook" under which to hang the detailed information models described by the GSM 12-series. A general description of each object class of the high level model, its purpose and use follows this introduction. The GDMO definition of each managed object class, associated attributes, etc. can be found in Annex A of this specification.

4.3.2.3 Network level object classes

The GSM-specific MOCS (see subclause 4.3.2.5) have the purpose of combining different perspectives or views of the same resource (or service) into a single object class. This avoids potential repetition of attributes - with the potential for data inconsistency when the model is instantiated - used in several aspects of the modelling process. It is the specific service or resource modeller's responsibility to recommend when or if a particular attribute(s) should be assigned to these objects. It is the responsibility of the high level modellers to identify candidate attributes when multiple detailed models are being produced.

The following Managed Object Classes (MOCs) define the highest level for a fully integrated PLMN management information model. Although described here in the context of a containment relationship it is expected that some generic object classes will also be used in inheritance relationships to derive PLMN specialisations. Formal GDMO definitions can be found in Annex A of this specification.

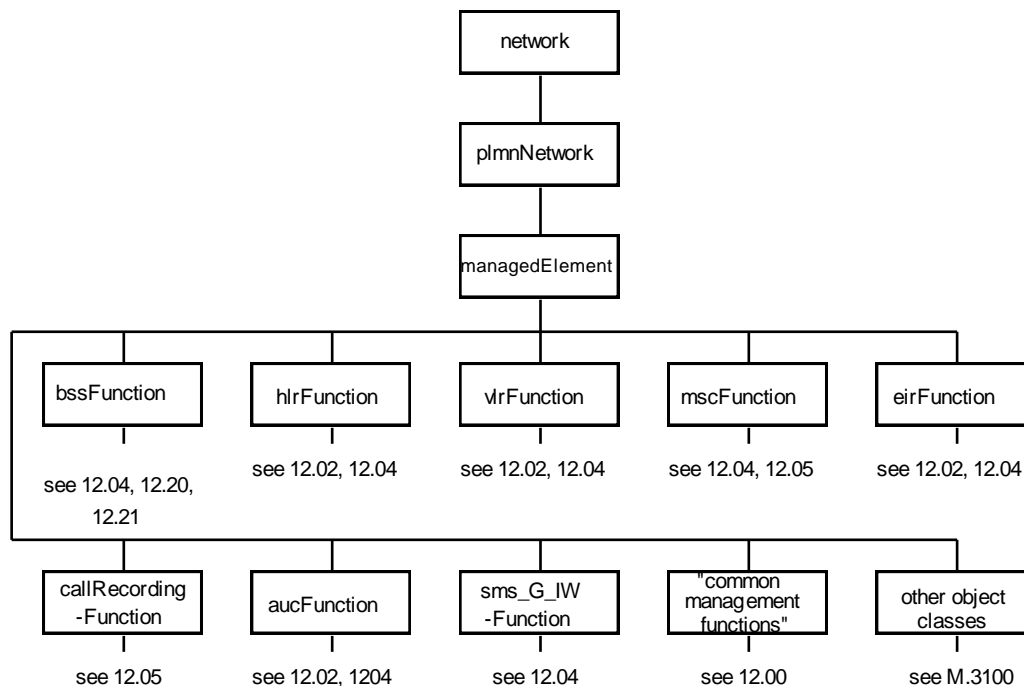

Figure 17/12.00: High Level Managed Object Class Containment

The network level object classes "network" and "plmnNetwork" are not instantiated in the Network Element and may only exist in the realm of the management systems (OSs). The network level object classes can provide the means for the manager system to identify the network, and the network components, being managed. An instance of "managedElement" cannot be created as the Network Element is regarded to 'exist'. As the description of "managedElement" states, this is the entry point for the instantiated information model for the management of any given Network Element, see CCITT Recommendation M.3100 [8].

"network" MOC

This MOC is defined in M.3100 and imported into the PLMN model unchanged. It represents an identifier for the telecommunications network being modelled. Sub-networks may be modelled by nesting "network" MOCs.

"plmnNetwork" MOC

This GSM-specific MOC describes the specific details which characterise a PLMN. These include the network identity. In accordance with the technique of M.3100, "plmnNetwork" contains the "managedElement" MOC.

"managedElement" MOC

This MOC is used as the fundamental starting point for the information modelling of the 12-series. It is defined in M.3100 as representing a component of a network which comprises functionality and/or hardware-software-data. In the core GSM specifications, functionality is defined as being assigned to specific network elements. In the high level object model, these network elements and the management services for the operation of the functionality are contained in this managed object class. The "managedElement" MOC contains MOCs to represent both functionality and equipment. (Equipment object classes specific to particular network elements may be contained in the specific element information model definition.) The "managedElement" MOC supports a Q3 interface for the purpose of being managed.

4.3.2.4 Other generic MOCs

A comprehensive management information model for a PLMN will require other generic managed object classes to be contained in the same hierarchy. These are grouped in the figure 17/12.00 as "other object classes". These MOCs are being defined by other standardization groups or bodies. (Please see CCITT M.3100 Generic Network Information Model [8] for more detailed information. This work is continuing.)

4.3.2.5 GSM specific MOCs

The "managedElement" MOC, as stated earlier, is used as the containment point for those MOCs which represent the identifiable GSM management services and GSM specific resource management models being defined by the 12-series of TSs. The two perspectives need to be drawn together in such a way as to allow flexibility in both the definition and the implementation possibilities while not causing confusion as to the purpose of the representation of the network management by the described MOCs.

The method adopted to identify the perspectives as modelling objectives has been to evaluate what is and is not node specific. (In this context, the term node is used to represent a GSM specified network element like MSC, HLR, VLR, BSS, etc.) This methodology, however, does not group all aspects of the ISO OSI functional management groupings (see Clause 5) which may be implemented on a single network element to be defined in a single object model. As an example, the configuration management of an HLR (subscriber database partitioning, etc.) will not be defined in the same leg of the model as the configuration of the call recording function as applicable to an HLR instance.

This approach is beneficial as it means that a particular management service may be implementable in its entirety without a dependence on another part of the entire object model which may fall into a different schedule for development. This methodology for producing self-contained definitions does not preclude the possibility of object relationships being established between multiple legs of the containment hierarchy as and when applicable.

The following MOCs have been identified and are described for the PLMN management information model. (Reference is given to the GSM 12-series TS where the detailed service or resource management model is to be found.)

"bssFunction" - this object introduces the management of the GSM defined radio base station. The modelling of the management of the BSS has been used as the pilot programme for the modelling process. The BSS model describes the

perspectives of both resource management and logical radio configuration management using the same managed object classes and attribute definitions.

- "hlrFunction" - this MOC represents those aspects of the HLR management which are seen to be common between the different components of that management.
- "vlrFunction" - this MOC represents those aspects of the VLR management which are seen to be common between the different components of that management.
- "mscFunction" - this MOC represents those aspects of the MSC management which are seen to be common between the different components of that management.
- "aucFunction" - this MOC represents those aspects of the AUC management which are seen to be common between the different components of that management.
- "eirFunction" - this MOC represents those aspects of the EIR management which are seen to be common between the different components of that management.
- "callRecordingFunction" - the Call Recording Function is a management service which describes the mechanisms and controls for the generation, collection and content of that data required to generate income from network usage. The function is described as a coherent whole but includes aspects which may be implemented on MSCs and HLRs.
- "smsGIWFunction" - the Short Message Service Gateway/Inter-working Function represents the ability of the PLMN to provide short messages to and receive short messages from a Service Centre.

NOTE: Other MOCs will be included as they are identified. Identified management services for GSM are:- management of location registers;- management of a BSS: see "bssFunction" MOC description;- management of cell data: see "bssFunction" MOC description;- management of radio planning data;- management of the AuC: this includes an aspect of subscriber management in GSM.

4.3.2.6 Management of signalling systems

GSM signalling is designed as an enhancement to CCITT signalling system number 7. Each defined network element will have to support management of this signalling system both in its standard form and the specific enhancements for GSM. It is proposed that the 12-series information model(s) will profit from the work performed by CCITT concerning the management of the signalling system (see CCITT Q.75x series) but that because the signalling system is such an integral part of the resource management it will be necessary to include specialised versions of the standard managed object classes into each resource management model in the 12-series. Therefore, for this particular aspect of management there is not an independent object defined for signalling system management in the PLMN information containment hierarchy.

4.3.2.7 Instantiation example

The high level model described in the preceding subclauses allows managed elements to be defined for management purposes according to the functionality contained within them. As an example for GSM, a single implementation of a combined MSC and VLR may be required. The management of the GSM functionalities for each network element are described in the GSM 12-series. However, in the implementation it is required to create a single Q3 interface for the management of this element.

This can be achieved by instantiating a Managed Element Managed Object Instance which contains the "mscFunction" MOC, the "vlrFunction" MOC, the "callRecordingFunction" MOC and other generic or non-GSM specific MOCs as appropriate to define the capability of that element to be managed according to standardized methods. Specific manufacturer-defined MOCs, which may have been defined as sub-classes of standardized MOCs can also be included. The manageability of the Managed Element so defined can be tested against the relevant MOCS and PICS.

A second aspect which will need to be considered during instantiation is the degree to which any one network element is able to support all of the management capabilities defined in the respective standard definition. In these cases, it may be necessary to produce a profile of the minimum expectations of the management capability for each defined GSM network element.

5 Introduction to the GSM Operations, Administration and Maintenance ETSS

This clause introduces the organization and scope of the series of GSM specifications concerned with Operations, Administration and Maintenance of PLMNs, known as the 12-series.

5.1 PLMN Management Functional Areas

Within CCITT X.701 [2] the Systems Management Functional Areas (SMFA) for Fault, Configuration, Accounting, Performance and Security Management have been identified.

For various, and mainly historical, reasons the existing breakdown in PLMN management functional areas is as follows:

- Administration and Commercial;
- Security;
- Operations and Performance;
- Change;
- Maintenance.

Nevertheless, this breakdown is as good as any according to CCITT M.3200 [6] and M.3020 [5] to describe the TMN Management Services and the TMN Management Service Components (Task 1 of M.3020).

The structure of the GSM 12-series is aligned to these areas and the following subclauses describe the common characteristics of each PLMN functional area.

5.1.1 Administration and commercial

This area includes all those functions which relate to management of subscribers, subscriber data, mobile equipment data, the collection of call data and other data upon which charges may be levied.

Invocation of these functions may be initiated for example from an ADC, which may be internal or external to the TMN, but control shall be exercised within the TMN. The processing of TMN generated data to produce charges are functions which are outside the scope of this series of recommendations.

The requirements for this functional area are defined in GSM 12.02 and 12.05.

5.1.2 Security

There are two aspects of security within a GSM network:

- security of subscriber access to and usage of the services offered;
- security of access to and usage of the TMN and, therefore, potentially sensitive or confidential PLMN data.

Described functions in this area shall provide for activity logging to enable the execution of security audit procedures. Most security mechanisms will be implemented in some form of hierarchy, the extent of which will relate to the organizational and responsibility levels of the PLMN Operator.

Areas which are not covered, but are important nevertheless, include:

- physical security, e.g. access to a site;
- data security; each functional area shall specify its own particular requirement. This may also be PLMN Operator dependent.

The requirements for this functional area are defined in GSM 12.03.

5.1.3 Operations and performance

This is the widest of functional areas. Typical functional sub-sets will include:

- performance data generation, gathering and analysis;
- traffic management;
- observations of grade of service and quality of service;
- the tracing of subscriber activity and related call path information (see GSM 12.02).

The objective shall be to describe and implement functions which allow the PLMN Operator to monitor the performance of the PLMN and, by means of the TMN, to alter the configuration of the PLMN to improve the quality of service provided to subscribers. Functions shall also be available to allow for the collection of detailed activity, call and call path information related to individually identifiable subscribers, i.e. by IMSI. The way in which these functions are used will be PLMN Operator dependent.

It is important, when these functions are defined, that a terminology is established, especially for measurements, to ensure that, in a multi-vendor environment, performance data can be readily compared without the necessity for local interpretation.

Generation techniques and transport mechanisms shall allow for the timely collection, analysis and display of performance data. It is equally, if not more, important to transport and execute traffic management commands and functions, especially when a PLMN is being subjected to heavy load.

The requirements for this functional area are defined in GSM 12.04 and 12.06.

5.1.4 Change

The management of change is considered separately as it does cross a number of functional area boundaries as specified in this clause.

The integrity of the PLMN, i.e. its ability to consistently perform the functions for which it was designed in the manner expected, is related to the stability of the network. Performing any change places the integrity at risk. Functions specifically designated to this area are those which minimize, if not eliminate, the risks.

Included may be such functions as:

- command validation;
- command sequencing;
- command verification;
- command blocking.

Change management also includes all those functions which log changes to the PLMN and/or the TMN and allow the network to be (re-)established to a known configuration or status.

When change functions relate to modifications of data values, they should determine whether the change is temporary or permanent, to be brought into instant use or delayed, to be secured or whether a reference database requires to be updated.

The requirements for this functional area are defined in GSM 12.06.

5.1.5 Maintenance

Included in this subclause is fault management. Functions shall be provided to allow:

- routine maintenance of switching and radio equipment;
- recognition, investigation, diagnosis and correction of faults;
- the recognition and logging of failures (by means of unsolicited alarm messages);
- routine testing of all PLMN and interconnect functions.

In a multi-vendor environment, it is essential that a standardized approach is adopted to ensure both the efficiency and the accuracy of the above processes.

Where possible, existing tried and tested procedures should be adopted. The functionality required to support fault and maintenance management within the GSM area shall also allow for new procedures. The

maintaining of system integrity through a fault condition, wherever it occurs within the PLMN, may be a critical requirement of functions in this area.

Requirements for this functional area are defined in GSM 12.11.

5.2 Management services

A TMN Management Service is seen as an area of management activity which provides for the support of an aspect of Operations, Maintenance or Administration of the network being managed, described from the user perception of the OAM requirements.

The final goal of the GSM 12-series is to support all management services needed to Operate, Administer and Maintain a PLMN network.

CCITT and ETSI have already defined Management Services to be supported by a TMN (see CCITT Recommendation M.3200 [6]). This work, and the further breakdown of the management services into TMN Management Service Components and TMN Management Functions are also considered useful to the management of a PLMN.

The applicability of the Management Services defined in CCITT Recommendation M.3200 [6] as they relate to a PLMN are classified as follows:

1. Applicable as is;
(referenced documents may describe the use of the service)
2. Not applicable; and,
3. Applicable with extensions/enhancements for mobile services.
(referenced documents may describe the requirement for the enhancement or extension)

Following is a list of the existing Management Services cross-referenced to the relevant 12-series specification and the classification of applicability to PLMN management:

1. Customer Administration (12.02 - 3)
2. Routing and Digit Analysis Administration (12.06 - 3)
3. Traffic Measurement and Analysis Administration (12.04 - 3)
4. Tariff and Charging Administration (12.05 - 3)
5. Management of the Security of the TMN (12.03 - 3)
6. Traffic Management (12.06 - 3)
7. Management of Customer Access (none - 2)
8. Management of Transport Network and Associated Equipment (12.06 - 1)
9. Switching Management (12.06 - 1)
10. Management of Equipment in Customer Premises (none - 2)
11. System Installation Administration (12.06 - 3)
12. Support Element Management (12.06 - 1)
13. QoS and Network Performance Administration (12.04, 12.07 - 3)
14. Management of the Customer Controlled Service (12.02 - 3)
15. Common Channel Signalling Management (12.06 - 3)
16. Management of Intelligent Networks (none - 2)
17. Restoration and Recovery (12.06 - 3, 12.11 - 3))
18. Materials Management (12.06 - 1)
19. Staff Work Scheduling (none - 2)
20. Management of the TMN (12.00 - 1)
21. Management of Routes and Circuits (12.06 - 3)

In addition to these Management Services, the following new management services are applicable for the management of a PLMN:

51. Management of Location Registers (12.02)
52. Management of a BSS (12.06, 12.11)
53. Management of Cell Data (12.06)
54. Management of Radio Planning Data (12.04, 12.06)

55. Management of the AuC (12.02, 12.03)
56. Management of Mobile Equipment Data (12.02, 12.05)

5.3 Management Service Components

The definition of a TMN Management Service Component (see CCITT Recommendation M.3020 [5]) is:

"The constituent parts of a TMN management service stating the requirements for actions to be performed on the managed network."

Each management service needs to be broken into its constituent parts - the components. Examples of components could include:

- change subscriber details;
- perform measurement job;
- reconfigure resource.

Each component then needs to be decomposed into its constituent parts, or management functions. A single management function may be common to more than one management service component and management service components will typically comprise of more than one management function.

The management services described in Subclause 5.1 cover the entire PLMN management requirements. Their breakdown into management service components is being performed in many TMN standards groups and bodies (e.g. see the draft CCITT recs Q.821 and Q.822 which describe Alarm Surveillance and Performance Measurement respectively [32] and [33]). This work will need to be re-used, if appropriate, in the definition of PLMN management.

The definition of management functions will also make use of the relevant ISO Systems Management definitions contained in the ISO 10164 series of standards (see [12] to [24]) to provide common solutions to common problems.

The particular environment of PLMN management may necessitate selective, expansive or common application of these management functions. The selective or expansive application is described in GSM 12.02 to GSM 12.11, including the related detailed information model descriptions (e.g. 12.20). Where multiple Management Services have identified a common use of these management functions, a definition of the common approach can be found in Annex B of this specification.

5.4 Structure of the GSM 12-Series

The management functions for the PLMN are described using ETSI and CCITT principles. The GSM 12-series is divided between network management and maintenance requirements.

NOTE: Both logical functions and physical requirements are described and that many maintenance activities utilize operational functions.

5.4.1 General specifications

These specifications are grouped into a single ETS 300 612. They provide the introduction to the GSM 12-series and describe functionality which is common to other GSM 12-series specifications.

12.00 Objectives And Structure Of PLMN Management

This is the fundamental specification that sets the framework for all the other 12 series specifications.

12.01 Common Aspects of PLMN Network Management;

This specification covers the common concepts and strategic aspects of PLMN Management which are specifically applicable to the PLMN, including example implementations.

A very important item of this specification is the definition of the protocols and profiles.

It defines the System Management Functions (SMF) used and it also specifies the basic communication services upon which the NM functions rely (CMIS, ACSE, ROSE, FTAM, etc.) and details of their use.

Therefore, this specification provides a common reference and background for the GSM 12 series in this area.

12.07 Quality Of Service

This specification is for further study.

5.4.2 Network Management Functions

The following specifications are individual ETSs within the 12-series. The descriptions are taken from the GSM Phase 2 versions of the documents. Each document is identified by its 12-series number and the assigned ETS number.

12.02 Subscriber, Mobile Equipment and Services Data Administration;

ETS 300 613

This specification gives a description of the functions associated with the administration of data related to subscribers, mobile equipments and services, specifically from the network management point of view.

This data, known as the Subscriber Profile, is used for the provision of services for a particular user of a PLMN, or for the user's equipment represented by the IMSI and the IMEI respectively. The functions include the administrative procedures for both the subscriber (for example 'provision of service'), and the equipment identified by the IMEI. Also included is the management of subscriber data necessary for network management.

The managed functional entities involved are the HLR, VLR, MSC, EIR, AUC. The administration of subscriber data in all these entities is part of this specification; which includes the means for a PLMN Operator to create, update, and delete information concerning a particular subscriber in order to allow (or bar) the use of the network

The following Management Services are covered:

1. Customer Administration
14. Management Of Customer Controlled Service
56. Management of Mobile Equipment Data.

12.03 Security Management;

ETS 300 614

This specification describes the management of the security related aspects of the air interface in the GSM/DCS PLMN. The management of the relevant security services is addressed with respect to the following aspects:

- overview of the security features
- description of the relevant management procedures
- modelling using the object oriented paradigm.

The definitions and descriptions of the security features and mechanisms are contained in the specifications of the underlying procedures and are not defined in this specification. References to

appropriate GSM/DCS specifications have been made throughout the document, where necessary. Issues relating to the security of management (e.g. file transfer security, database security, inter-operator security, etc.) are not covered in this specification.

12.04 Performance Management And Measurements In A GSM PLMN;

ETS 300 615

This Technical Specification gives a description of the requirements for the management of performance measurements and the collection of performance measurement data across a PLMN. It defines the administration of measurement schedules, the generation of measurement results in the NEs and the transfer of these results to the OS. It also describes how the various requirements can be modelled as part of the generic PLMN information model. A set of measurements available for collection by NEs are described.

The following Management Services are covered:

3. Traffic Measurement And Analysis Administration

12.05 Subscriber Related Call And Event Data;

ETS 300 616

This specification is concerned with the administration of subscriber related call and event data. This includes both the collection of call data from, and the distribution of tariff to, the network elements.

The subscriber (IMSI) and mobile equipment (IMEI) related call and event data collected is employed by a number of management activities including billing and accounting, statistical analysis and customer care.

The tariff data in the network elements is required to support the supplementary service "Advice of Charge".

The aim of this specification is to describe both the network management functions required and the data involved.

The following Management Services are covered:

4. Tariff and Charging Administration (including Accounting)
56. Management of Mobile Equipment Data

12.06 GSM Network Change Control;

ETS 300 617

This ETS describes the Configuration Management (CM) aspects of Network Elements (NE) which comprise a PLMN, with initial emphasis on the BSS management. This is described from a management perspective being decomposed into constituent functionalities, which in turn will allow the construction of a management information model, following the methodology described in GSM 12.00.

This ETS defines a set of controls to be employed to effect set-up and changes to a PLMN, in such a way that operational capability, network integrity and inter-working co-operation are ensured. In this way, this ETS describes the interface behaviour for the management of PLMN NEs in the context of the described management environment. The context is described for both the OS and NE functionality. The standardisation of specific controls is outside of the scope of this ETS.

The following Management Services are covered:

2. Routing and Digit Analysis Administration
6. Traffic Management
11. System Installation Administration
12. Support Element Management
15. Common Channel Signalling Management
17. Restoration and Recovery
18. Materials Management
21. Management of Routes and Circuits.

12.08 Subscriber and Equipment Trace;

ETS 300 627

This ETS specifies the Trace facility for GSM where it refers to:

- Subscriber tracing (tracing of IMSI);
- Equipment tracing (tracing of IMEI).

It does not cover types of trace which relate more to network elements than to individual subscribers, e.g. tracing events within a BSS, and so on.

12.11 Fault Management Of The Base Station System;

ETS 300 619

(This specification is for further study for GSM Phase 2.)

The following Management Services are expected to be covered:

52. Management of a BSS

5.4.3 TMN interface specifications

The following ETSs define the management information models and structured procedures for the management of GSM network elements.

The relationships between the TMN interface specifications for GSM, and their relationship to GSM 12.01, are shown in figure 13/12.00.

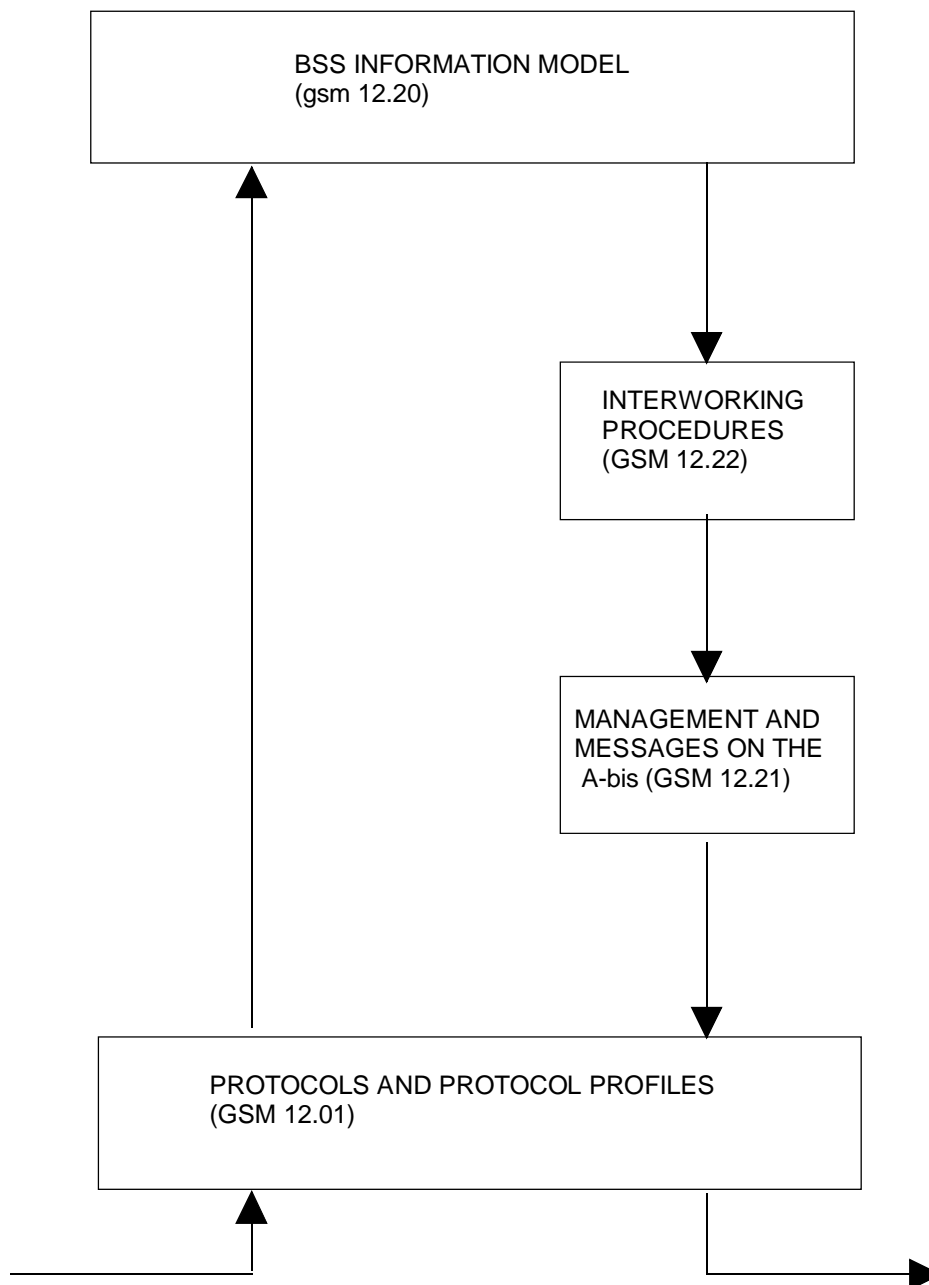

Figure 13/12.00: Relationship between Technical Specifications GSM 12.01, 12.20, 12.21 and 12.22 (Ref section 5.4.3)

12.20 Network Management Procedures And Messages;

ETS 300 622

This specification provides the management information model for the GSM BSS Network Element as seen on the Q3 interface between the OS (e.g. OMC) and the BSS. The management information defined in this document is primarily related to what is termed Configuration Management within CCITT X.701 definition of Systems Management Functional Areas. In addition to formal GDMO definitions, information is included to aid in understanding the model and its elements. Summary descriptions, containment and inheritance diagrams, and entity relationship diagrams are provided for this purpose.

12.21 Network Management Procedures And Messages On The A-bis Interface.

ETS 300 623

This specification addresses the network management messages and procedures across the A-bis interface, which is defined as Qx in GSM. The information model included here defines the objects and how they are addressed for purposes of operations and maintenance activities.

There is a requirement for the A-bis interface to be open to allow interoperation between BTSs of different manufacturers working to the same BSC. This specification addresses this requirement from the O&M point of view, which allows this inter-working to take place. It shows the split of NM functions between BSC and BTS. The procedures and coding of the messages are specified in detail.

12.22 Inter-working Of Management Procedures And Messages At The BSC

ETS 300 624

To ensure management of different manufacturers' BTS from the OMC through the BSC in a standardized way, BSC inter working is needed to link the 12.20 on the OMC-BSC interface and the 12.21 on the A-bis interface.

On the OMC-BSC interface the description of BTS and its components follows an object-oriented approach. On the A-bis interface the addressing of managed objects is a compromise between an object-oriented and a functional approach. 12.22 specifies the mapping of two different information models: information model in the OMC-BSC interface and in the A-bis interface.

The scope of this recommendation is to cover the inter-working specification related to the BSC.

12.30 (ETR 128) ETSI object identifier tree; Common domain Mobile domain O & M managed object registration definition.

This report describes the structure to be used for the registration of the managed object classes and associated descriptions within the ETSI identifier tree.

Annex A (normative): GDMO definitions for GSM-Specific High Level Managed Objects

This Annex to GSM 12.00 contains the formal GDMO definitions of those Managed Object Classes described in Subclause 4.3.2 as being specific to the management information model for GSM.

A.1 Managed Object Classes

A.1.1 aucFunction

```
aucFunction MANAGED OBJECT CLASS
  DERIVED FROM
    "Recommendation X.721: 1992": top;
  CHARACTERIZED BY
    aucFunctionPackageCommon,
    "GSM 12.02: 1994": aucFunctionPackage1202;
  CONDITIONAL PACKAGES
    "Recommendation M.3100: 1992": createDeleteNotificationsPackage PRESENT IF
      "the objectCreation and objectDeletion notifications (as defined in CCITT X.721) are
      supported by this managed object",

    "Recommendation M.3100: 1992": attributeValueChangeNotificationPackage PRESENT IF
      "the attributeValueChange notification (as defined in CCITT X.721) is supported by
      this managed object",

    "Recommendation M.3100: 1992": stateChangeNotificationPackage PRESENT IF
      "the stateChange notification (as defined in CCITT X.721) is supported by this
      managed object"
  ;
```

```
RESIGTERED AS {gsm1200AmanagedObjectClass 10};
```

```
aucFunctionPackageCommon PACKAGE
  BEHAVIOUR
    aucFunctionPackageCommonBehaviour
  ;
  ATTRIBUTES
    aucFunctionId GET,
    "Recommendation X.721: 1992": administrativeState GET-REPLACE,
    "Recommendation X.721: 1992": operationalState GET
  ;
```

```
RESIGTERED AS {gsm1200Apackage 10};
```

```
aucFunctionPackageCommonBehaviour BEHAVIOUR
  DEFINED AS
  "The aucFunction is contained as a functional managed object class by managedElement. The
  aucFunction comprises all functions necessary to implement an AUC in a managedElement.
  This package contains the common attributes required by all sub-functions"
  ;
```

A.1.2 bssFunction

```
bssFunction MANAGED OBJECT CLASS
  DERIVED FROM
    "Recommendation X.721: 1992": top;
  CHARACTERIZED BY
    bssFunctionPackage;
REGISTERED AS {gsm1200AmanagedObjectClass 20};

  bssFunctionPackage PACKAGE
  BEHAVIOUR
    bssFunctionBehaviour
  ;
  ATTRIBUTES
    bssFunctionId GET
  ;
```

REGISTERED AS {gsm1200Apackage 20};

bssFunctionBehaviour **BEHAVIOUR**
DEFINED AS

"The bssFunction object class is that class of managed objects which models the functionality of the GSM Network Element BSS. Its purpose is containment, allowing the association of various functionalities that make up an instance of this Network Element."
;

A.1.3 callRecordingFunction

(The formal GDMO definition of the "callRecordingFunction Managed Object Class can be found in GSM 12.05. It is listed here for completeness of the overall picture of the high level containment.)

A.1.4 eirFunction

eirFunction **MANAGED OBJECT CLASS**

DERIVED FROM

"Recommendation X.721": top;

CHARACTERIZED BY

eirFunctionPackageCommon,
"GSM 12.02: 1994": eirFunctionPackage1202;

CONDITIONAL PACKAGES

"Recommendation M.3100: 1992": createDeleteNotificationsPackage **PRESENT IF**
"the objectCreation and objectDeletion notifications (as defined in CCITT X.721) are supported by this managed object",

"Recommendation M.3100: 1992": attributeValueChangeNotificationPackage **PRESENT IF**
"the attributeValueChange notification (as defined in CCITT X.721) is supported by this managed object",

"Recommendation M.3100: 1992": stateChangeNotificationPackage **PRESENT IF**
"the stateChange notification (as defined in CCITT X.721) is supported by this managed object"

;

RESIGTERED AS {gsm1200AmanagedObjectClass 30};

eirFunctionPackageCommon **PACKAGE**

BEHAVIOUR

eirFunctionPackageCommonBehaviour

;

ATTRIBUTES

eirFunctionId **GET,**
"Recommendation X.721: 1992": administrativeState **GET-REPLACE,**
"Recommendation X.721: 1992": operationalState **GET,**
eirId **GET-REPLACE,**
eirNumber **GET-REPLACE**

;

RESIGTERED AS {gsm1200Apackage 30};

eirFunctionPackageCommonBehaviour **BEHAVIOUR**

DEFINED AS

"The eirFunction comprises all functions necessary to implement an EIR in a managedElement. This package contains the common attributes required by all sub-functions"

;

A.1.5 hlrFunction

hlrFunction **MANAGED OBJECT CLASS**

DERIVED FROM

"Recommendation X.721: 1992": top;

CHARACTERIZED BY

hlrFunctionPackageCommon,
"GSM 12.02: 1994": hlrFunctionPackage1202;

CONDITIONAL PACKAGES

"Recommendation M.3100: 1992": createDeleteNotificationsPackage **PRESENT IF**
"the objectCreation and objectDeletion notifications (as defined in CCITT X.721) are

supported by this managed object",

"Recommendation M.3100: 1992": attributeValueChangeNotificationPackage **PRESENT IF**
"the attributeValueChange notification (as defined in CCITT X.721) is supported by
this managed object",

"Recommendation M.3100: 1992": stateChangeNotificationPackage **PRESENT IF**
"the stateChange notification (as defined in CCITT X.721) is supported by this
managed object"

;

REGISTERED AS {gsm1200AmanagedObjectClass 40};

hlrFunctionPackageCommon **PACKAGE**

BEHAVIOUR

 hlrFunctionPackageCommonBehaviour

;

ATTRIBUTES

 hlrFunctionId

GET,

 "Recommendation X.721: 1992": administrativeState

GET-REPLACE,

 "Recommendation X.721: 1992": operationalState

GET

;

REGISTERED AS {gsm1200Apackage 40};

hlrFunctionPackageCommonBehaviour **BEHAVIOUR**

DEFINED AS

"The hlrFunction comprises all functions necessary to implement an HLR in a
managedElement. This package contains the common attributes required by all sub-
functions"

;

A.1.6 mscFunction

mscFunction **MANAGED OBJECT CLASS**

DERIVED FROM

 "Recommendation X.721: 1992": top;

CHARACTERIZED BY

 mscFunctionPackageCommon;

CONDITIONAL PACKAGES

 "Recommendation M.3100: 1992": createDeleteNotificationsPackage

PRESENT IF

 "the objectCreation and objectDeletion notifications (as defined in CCITT X.721) are
supported by this managed object",

 "Recommendation M.3100: 1992": attributeValueChangeNotificationPackage

PRESENT IF

 "the attributeValueChange notification (as defined in CCITT X.721) is supported by
this managed object",

 "Recommendation M.3100: 1992": stateChangeNotificationPackage

PRESENT IF

 "the stateChange notification (as defined in CCITT X.721) is supported by this
managed object"

;

REGISTERED AS {gsm1200AmanagedObjectClass 50};

mscFunctionPackageCommon **PACKAGE**

BEHAVIOUR

 mscFunctionPackageCommonBehaviour

;

ATTRIBUTES

 mscFunctionId

GET,

 "Recommendation X.721: 1992": administrativeState

GET-REPLACE,

 "Recommendation X.721: 1992": operationalState

GET,

 mscId

GET-REPLACE,

 mscNumber

GET-REPLACE

;

REGISTERED AS {gsm1200Apackage 50};

mscFunctionPackageCommonBehaviour **BEHAVIOUR**

DEFINED AS

"The mscFunction comprises all functions necessary to implement an MSC in a managedElement. This package contains the common attributes required by all sub-functions"

;

A.1.7 plmnNetwork

plmnNetwork **MANAGED OBJECT CLASS**

DERIVED FROM

"Recommendation M.3100: 1992":network;

CHARACTERIZED BY

plmnNetworkPackage;

CONDITIONAL PACKAGES

"Recommendation M.3100: 1992": createDeleteNotificationsPackage **PRESENT IF**
"the objectCreation and objectDeletion notifications (as defined in CCITT X.721) are supported by this managed object",

"Recommendation M.3100: 1992": attributeValueChangeNotificationPackage **PRESENT IF**
"the attributeValueChange notification (as defined in CCITT X.721) is supported by this managed object"

;

REGISTERED AS {gsm1200AmanagedObjectClass 60};

plmnNetworkPackage **PACKAGE**

BEHAVIOUR

plmnNetworkPackageBehaviour;

ATTRIBUTES

mcc	GET-REPLACE,
mnc	GET-REPLACE,
setOfCc	GET-REPLACE,
setOfNdc	GET-REPLACE,
listOfSupportedBS	GET-REPLACE
	ADD-REMOVE,
listOfSupportedSS	GET-REPLACE
	ADD-REMOVE;

REGISTERED AS {gsm1200Apackage 60};

plmnNetworkPackageBehaviour **BEHAVIOUR**

DEFINED AS

"The network object class is a class of managed objects that are a collection of interconnected telecommunications and management objects (logical and physical) capable of exchanging information. These objects have one or more common characteristics and can form containment relationships. A plmnNetwork object instance may be contained in a M.3100 network object if the PLMN network is part of a more general network.

The plmnNetwork object class includes, in addition to the packages inherited from network, a plmnNetworkPackage with attributes general to the whole PLMN network."

;

A.1.8 smsGIWFunction

smsGIWFunction **MANAGED OBJECT CLASS**

DERIVED FROM

"Recommendation X.721: 1992": top;

CHARACTERIZED BY

smsGIWFunctionPackageCommon;

CONDITIONAL PACKAGES

"Recommendation M.3100: 1992": createDeleteNotificationsPackage **PRESENT IF**
"the objectCreation and objectDeletion notifications (as defined in CCITT X.721) are supported by this managed object",

"Recommendation M.3100: 1992": attributeValueChangeNotificationPackage **PRESENT IF**
"the attributeValueChange notification (as defined in CCITT X.721) is supported by this managed object",

"Recommendation M.3100: 1992" stateChangeNotificationPackage **PRESENT IF**
"the stateChange notification (as defined in CCITT X.721) is supported by this

managed object"

;

REGISTERED AS {gsm1200AmanagedObjectClass 70};

smsGIWFunctionPackageCommon **PACKAGE**

BEHAVIOUR

smsGIWFunctionPackageCommonBehaviour

;

ATTRIBUTES

smsGIWFunctionId

GET,

"Recommendation X.721: 1992": administrativeState

GET-REPLACE,

"Recommendation X.721: 1992": operationalState

GET

;

REGISTERED AS {gsm1200Apackage 70};

smsGIWFunctionPackageCommonBehaviour **BEHAVIOUR**

DEFINED AS

"The smsGIWFunction managed object class represents the ability of a PLMN to receive from and/or send to a Short Message Service Centre, short messages."

;

A.1.9 vlrFunction

```
vlrFunction MANAGED OBJECT CLASS
  DERIVED FROM
    "Recommendation X.721: 1992": top;
  CHARACTERIZED BY
    vlrFunctionPackageCommon,
    "GSM 12.02: 1994": vlrFunctionPackage1202;
  CONDITIONAL PACKAGES
    "Recommendation M.3100: 1992": createDeleteNotificationsPackage PRESENT IF
    "the objectCreation and objectDeletion notifications (as defined in CCITT X.721) are
supported by this managed object",

    "Recommendation M.3100: 1992": attributeValueChangeNotificationPackage PRESENT IF
    "the attributeValueChange notification (as defined in CCITT X.721) is supported by
this managed object",

    "Recommendation M.3100: 1992": stateChangeNotificationPackage PRESENT IF
    "the stateChange notification (as defined in CCITT X.721) is supported by this
managed object"
  ;

REGISTERED AS {gsm1200AmanagedObjectClass 80};

vlrFunctionPackageCommon PACKAGE
  BEHAVIOUR
    vlrFunctionPackageCommonBehaviour
  ;
  ATTRIBUTES
    vlrFunctionId GET,
    "Recommendation X.721: 1992": administrativeState GET-REPLACE,
    "Recommendation X.721: 1992": operationalState GET,
    vlrId GET-REPLACE,
    vlrNumber GET-REPLACE
  ;
REGISTERED AS {gsm1200Apackage 80};

vlrFunctionPackageCommonBehaviour BEHAVIOUR
  DEFINED AS
  "The vlrFunction comprises all functions necessary to implement a VLR in a
managedElement. This package contains the common attributes required by all sub-
functions"
  ;
```

A.2 Package definitions

Packages are defined within the related managed object class.

A.3 ATTRIBUTE DEFINITIONS

A.3.1 aucFunctionId

```
aucFunctionId ATTRIBUTE  
  WITH ATTRIBUTE SYNTAX  
    GSM1200ATypeModule.AucFunctionId;  
  MATCHES FOR  
    EQUALITY;  
  BEHAVIOUR  
    aucFunctionIdBehaviour;  
REGISTERED AS {gsm1200Aattribute 10};
```

```
aucFunctionIdBehaviour BEHAVIOUR  
  DEFINED AS  
  "This attribute names an aucFunction object instance. Its value must be unique within the  
parent PLMN."  
;
```

A.3.2 bssFunctionId

```
bssFunctionId ATTRIBUTE  
  WITH ATTRIBUTE SYNTAX  
    GSM1200ATypeModule.BssFunctionID;  
  MATCHES FOR  
    EQUALITY, ORDERING;  
  BEHAVIOUR  
    bssFunctionIdBehaviour;  
REGISTERED AS {gsm1200Aattribute 20};
```

```
bssFunctionIdBehaviour BEHAVIOUR  
  DEFINED AS  
  "This attribute names a bssFunction object instance. Its value must be unique within the  
parent PLMN."  
;
```

A.3.3 setOfCc

```
setOfCc ATTRIBUTE  
  WITH ATTRIBUTE SYNTAX  
    GSM1200ATypeModule.SetOfCc;  
  MATCHES FOR  
    EQUALITY;  
  BEHAVIOUR  
    setOfCcBehaviour;  
REGISTERED AS {gsm1200Aattribute 30};
```

```
setOfCcBehaviour BEHAVIOUR  
  DEFINED AS  
  "This attribute contains the country codes (more than one may be assigned to one network)  
of the PLMN, as defined in GSM TS 03.08. It may be used to insert the CC and NDC when  
sending out the MSISDN as an international number"  
;
```

A.3.4 eirFunctionId

```
eirFunctionId ATTRIBUTE  
  WITH ATTRIBUTE SYNTAX  
    GSM1200ATypeModule.EirFunctionId;  
  MATCHES FOR  
    EQUALITY;  
  BEHAVIOUR
```



```
    eirFunctionIdBehaviour;  
REGISTERED AS {gsm1200Aattribute 40};
```

```
eirFunctionIdBehaviour BEHAVIOUR  
DEFINED AS
```

```
"This attribute names a eirFunction object instance. Its value must be unique within the  
parent PLMN."  
;
```

A.3.5 eirId

```
eirId ATTRIBUTE  
WITH ATTRIBUTE SYNTAX  
    GSM1200ATypeModule.EirId;  
MATCHES FOR  
    EQUALITY;  
BEHAVIOUR  
    eirIdBehaviour;  
REGISTERED AS {gsm1200Aattribute 50};
```

```
eirIdBehaviour BEHAVIOUR  
DEFINED AS
```

```
"This attribute contains the identification of the EIR represented by this eirFunction  
instance"  
;
```

A.3.6 eirNumber

```
eirNumber ATTRIBUTE  
WITH ATTRIBUTE SYNTAX  
    GSM1200ATypeModule.EirNumber;  
MATCHES FOR  
    EQUALITY;  
BEHAVIOUR  
    eirNumberBehaviour;  
REGISTERED AS {gsm1200Aattribute 60};
```

```
eirNumberBehaviour BEHAVIOUR  
DEFINED AS
```

```
"This attribute contains the ISDN-Number of the EIR represented by this eirFunction  
instance. It is used to address the EIR via signalling"  
;
```

A.3.7 hlrFunctionId

```
hlrFunctionId ATTRIBUTE  
WITH ATTRIBUTE SYNTAX  
    GSM1200ATypeModule.HlrFunctionId;  
MATCHES FOR  
    EQUALITY;  
BEHAVIOUR  
    hlrFunctionIdBehaviour;  
REGISTERED AS {gsm1200Aattribute 70};
```

```
hlrFunctionIdBehaviour BEHAVIOUR  
DEFINED AS
```

```
"This attribute names an hlrFunction object instance. Its value must be unique within the  
parent PLMN."  
;
```

A.3.8 listOfSupportedBS

```
listOfSupportedBS ATTRIBUTE  
WITH ATTRIBUTE SYNTAX  
    GSM1200ATypeModule.ListOfSupportedBS;  
MATCHES FOR  
    EQUALITY, SET-INTERSECTION, SET-COMPARISON;  
BEHAVIOUR  
    listOfSupportedBSBehaviour;
```

REGISTERED AS {gsm1200Aattribute 80};

listOfSupportedBSBehaviour **BEHAVIOUR**

DEFINED AS

"This attribute contains a list of the basic services supported within this network. It may be used for error checking with the creation of basicServiceInHlr (see GSM TS 12.02) objects or for subscription checking within the VLR."

;

A.3.9 listOfSupportedSS

listOfSupportedSS **ATTRIBUTE**
WITH ATTRIBUTE SYNTAX
GSM1200ATypeModule.ListOfSupportedSS;
MATCHES FOR
EQUALITY, SET-INTERSECTION, SET-COMPARISON;
BEHAVIOUR
listOfSupportedSSBehaviour;
REGISTERED AS {gsm1200Aattribute 90};

listOfSupportedSSBehaviour **BEHAVIOUR**
DEFINED AS

"This attribute contains a list of the supplementary services supported within this network. It may be used for error checking with the creation of supplementaryServiceInHlr (see GSM TS 12.02) objects or for subscription checking within the VLR."
;

A.3.10 mcc

mcc **ATTRIBUTE**
WITH ATTRIBUTE SYNTAX
GSM1200ATypeModule.Mcc;
MATCHES FOR
EQUALITY;
BEHAVIOUR
mccBehaviour;
REGISTERED AS {gsm1200Aattribute 100};

mccBehaviour **BEHAVIOUR**
DEFINED AS

"This attribute contains the Mobile Country Code of the network as defined in GSM TS 03.08. It may be used within the hlrFunction to store an IMSI without MCC and MNC or to distinguish between own subscribers and roaming subscribers."
;

A.3.11 mnc

mnc **ATTRIBUTE**
WITH ATTRIBUTE SYNTAX
GSM1200ATypeModule.Mnc;
MATCHES FOR
EQUALITY;
BEHAVIOUR
mncBehaviour;
REGISTERED AS {gsm1200Aattribute 110};

mncBehaviour **BEHAVIOUR**
DEFINED AS

"This attribute contains the Mobile Network Code of the network as defined in GSM TS 03.08. It may be used within the hlrFunction to store an IMSI without MCC and MNC or to distinguish between own subscribers and roaming subscribers."
;

A.3.12 mscFunctionId

mscFunctionId **ATTRIBUTE**
WITH ATTRIBUTE SYNTAX
GSM1200ATypeModule.MscFunctionId;
MATCHES FOR
EQUALITY;
BEHAVIOUR
mscFunctionIdBehaviour;
REGISTERED AS {gsm1200Aattribute 120};

mscFunctionIdBehaviour **BEHAVIOUR**
DEFINED AS

"This attribute names a mscFunction object instance. Its value must be unique within the

parent PLMN."

;

A.3.13 mscId

```
mscId ATTRIBUTE  
  WITH ATTRIBUTE SYNTAX  
    GSM1200ATypeModule.MscId;  
  MATCHES FOR  
    EQUALITY;  
  BEHAVIOUR  
    mscIdBehaviour;  
REGISTERED AS {gsm1200Aattribute 130};
```

```
mscIdBehaviour BEHAVIOUR  
  DEFINED AS  
  "This attribute contains the identification of the MSC represented by this mscFunction  
  instance."  
  ;
```

A.3.14 mscNumber

```
mscNumber ATTRIBUTE  
  WITH ATTRIBUTE SYNTAX  
    GSM1200ATypeModule.MscNumber;  
  MATCHES FOR  
    EQUALITY;  
  BEHAVIOUR  
    mscNumberBehaviour;  
REGISTERED AS {gsm1200Aattribute 140};
```

```
mscNumberBehaviour BEHAVIOUR  
  DEFINED AS  
  "This attribute contains the ISDN-Number of the MSC represented by this mscFunction  
  instance. It is used to address the MSC via signalling."  
  ;
```

A.3.15 setOfNdc

```
setOfNdc ATTRIBUTE  
  WITH ATTRIBUTE SYNTAX  
    GSM1200ATypeModule.SetOfNdc;  
  MATCHES FOR  
    EQUALITY;  
  BEHAVIOUR  
    setOfNdcBehaviour;  
REGISTERED AS {gsm1200Aattribute 150};
```

```
setOfNdcBehaviour BEHAVIOUR  
  DEFINED AS  
  "This attribute contains the Network Destination Codes of the network as defined in GSM  
  TS 03.08. More than one NDC may be assigned to one PLMN. They may be used to insert the  
  CC and NDC when sending out the MSISDN as an international number."  
  ;
```

A.3.16 smsGIWFunctionId

```
smsGIWFunctionId ATTRIBUTE  
  WITH ATTRIBUTE SYNTAX  
    GSM1200ATypeModule.SmsGIWFunctionId;  
  MATCHES FOR  
    EQUALITY;  
  BEHAVIOUR  
    smsGIWFunctionIdBehaviour;  
REGISTERED AS {gsm1200Aattribute 160};
```

```
smsGIWFunctionIdBehaviour BEHAVIOUR  
  DEFINED AS  
  "This attribute names a smsGIWFunction object instance. Its value must be unique within  
  the parent PLMN."  
  ;
```

A.3.17 vlrFunctionId

```
vlrFunctionId ATTRIBUTE
  WITH ATTRIBUTE SYNTAX
    GSM1200ATypeModule.VlrFunctionId;
  MATCHES FOR
    EQUALITY;
  BEHAVIOUR
    vlrFunctionIdBehaviour;
REGISTERED AS {gsm1200Aattribute 170};

vlrFunctionIdBehaviour BEHAVIOUR
  DEFINED AS
  "This attribute names a vlrFunction object instance. Its value must be unique within the
  parent PLMN."
;
```

A.3.18 vlrId

```
vlrId ATTRIBUTE
  WITH ATTRIBUTE SYNTAX
    GSM1200ATypeModule.VlrId;
  MATCHES FOR
    EQUALITY;
  BEHAVIOUR
    vlrIdBehaviour;
REGISTERED AS {gsm1200Aattribute 180};

vlrIdBehaviour BEHAVIOUR
  DEFINED AS
  "This attribute contains the identification of the VLR represented by this instance of
  vlrFunction."
;
```

A.3.19 vlrNumber

```
vlrNumber ATTRIBUTE
  WITH ATTRIBUTE SYNTAX
    GSM1200ATypeModule.VlrNumber;
  MATCHES FOR
    EQUALITY;
  BEHAVIOUR
    vlrNumberBehaviour;
REGISTERED AS {gsm1200Aattribute 190};

vlrNumberBehaviour BEHAVIOUR
  DEFINED AS
  "This attribute contains ISDN-Number of the VLR represented by this instance of
  vlrFunction. It is used to address the VLR via signalling."
;
```

A.4 Actions

There are no Actions defined in this part of this specification.

A.5 Notifications

All Notifications used in this specification are defined in CCITT rec. X.721.

A.6 Parameters

There are no Parameters defined in this part of this specification.

A.7 NAME BINDINGS

A.7.1 managedElement-plmnNetwork NAME BINDING

```
managedElement-plmnNetwork NAME BINDING
  SUBORDINATE OBJECT CLASS managedElement;
  NAMED BY
  SUPERIOR OBJECT CLASS plmnNetwork;
  WITH ATTRIBUTE managedElementId;
  BEHAVIOUR managedElement-plmnNetworkBehaviour;
  CREATE;
  DELETE;
REGISTERED AS {gsm1200AnameBinding 10};
```

```
managedElement-plmnNetworkBehaviour BEHAVIOUR
  DEFINED AS
  "
  "
  ;
```

A.7.2 hlrFunction-managedElement NAME BINDING

```
hlrFunction-managedElement NAME BINDING
  SUBORDINATE OBJECT CLASS hlrFunction;
  NAMED BY
  SUPERIOR OBJECT CLASS managedElement;
  WITH ATTRIBUTE hlrFunctionId;
  BEHAVIOUR hlrFunction-managedElementBehaviour;
  CREATE;
  DELETE;
REGISTERED AS {gsm1200AnameBinding 20};
```

```
hlrFunction-managedElementBehaviour BEHAVIOUR
  DEFINED AS
  "
  "
  ;
```

A.7.3 aucFunction-managedElement NAME BINDING

```
aucFunction-managedElement NAME BINDING
  SUBORDINATE OBJECT CLASS aucFunction;
  NAMED BY
  SUPERIOR OBJECT CLASS managedElement;
  WITH ATTRIBUTE aucFunctionId;
  BEHAVIOUR aucFunction-managedElementBehaviour;
  CREATE;
  DELETE;
REGISTERED AS {gsm1200AnameBinding 30};
```

```
aucFunction-managedElementBehaviour BEHAVIOUR
  DEFINED AS
  "
  "
  ;
```

A.7.4 vlrFunction-managedElement NAME BINDING

```
vlrFunction-managedElement NAME BINDING
  SUBORDINATE OBJECT CLASS vlrFunction;
  NAMED BY
  SUPERIOR OBJECT CLASS managedElement;
  WITH ATTRIBUTE vlrFunctionId;
  BEHAVIOUR vlrFunction-managedElementBehaviour;
  CREATE;
  DELETE;
REGISTERED AS {gsm1200AnameBinding 40};
```



```
vlrFunction-managedElementBehaviour BEHAVIOUR  
  DEFINED AS  
  "  
  "  
  ;
```

A.7.5 mscFunction-managedElement NAME BINDING

```

mscFunction-managedElement NAME BINDING
  SUBORDINATE OBJECT CLASS mscFunction;
  NAMED BY
  SUPERIOR OBJECT CLASS managedElement;
  WITH ATTRIBUTE mscFunctionId;
  BEHAVIOUR mscFunction-managedElementBehaviour;
  CREATE;
  DELETE;
REGISTERED AS {gsm1200AnameBinding 50};

```

```

mscFunction-managedElementBehaviour BEHAVIOUR
  DEFINED AS
  "
  "
  ;

```

A.7.6 eirFunction-managedElement NAME BINDING

```

eirFunction-managedElement NAME BINDING
  SUBORDINATE OBJECT CLASS eirFunction;
  NAMED BY
  SUPERIOR OBJECT CLASS managedElement;
  WITH ATTRIBUTE eirFunctionId;
  BEHAVIOUR eirFunction-managedElementBehaviour;
  CREATE;
  DELETE;
REGISTERED AS {gsm1200AnameBinding 60};

```

```

eirFunction-managedElementBehaviour BEHAVIOUR
  DEFINED AS
  "
  "
  ;

```

A.7.7 bssFunction-managedElement NAME BINDING

```

bssFunction-managedElement NAME BINDING
  SUBORDINATE OBJECT CLASS bssFunction;
  NAMED BY
  SUPERIOR OBJECT CLASS managedElement;
  WITH ATTRIBUTE bssFunctionId;
  BEHAVIOUR bssFunction-managedElementBehaviour;
  CREATE;
  DELETE;
REGISTERED AS {gsm1200AnameBinding 70};

```

```

bssFunction-managedElementBehaviour BEHAVIOUR
  DEFINED AS
  "
  "
  ;

```

A.7.8 smsGIWFunction-managedElement NAME BINDING

```

smsGIWFunction-managedElement NAME BINDING
  SUBORDINATE OBJECT CLASS smsGIWFunction;
  NAMED BY
  SUPERIOR OBJECT CLASS managedElement;
  WITH ATTRIBUTE smsGIWFunctionId;
  BEHAVIOUR smsGIWFunction-managedElementBehaviour;
  CREATE;
  DELETE;
REGISTERED AS {gsm1200AnameBinding 80};

```

```
smsGIWFunction-managedElementBehaviour BEHAVIOUR  
  DEFINED AS  
  "  
  "  
  ;
```

A.8 SYNTAX DEFINITIONS

```
GSM1200ATypeModule {ccitt (0) identified-organization (4) etsi (0) mobileDomain (0) gsm-  
Operation-Maintenance (3) gsm-12-00 (0) annexA (0) informationModel (0) asn1Module (2)  
version1 (1)}
```

```
DEFINITION IMPLICIT TAGS ::=
```

```
BEGIN
```

```
IMPORTS
```

```
    gsm-12-00A
```

```
FROM GSM-DomainDefinitions
```

```
{ccitt (0) identified-organization (4) etsi (0) mobileDomain (0)  
gsm-Operation-Maintenance (3) gsm-12-30 (30) informationModel (0)  
asn1Module (2) gsm-OM-DomainDefinition (0) version1 (1)}  
ISDN-AddressString
```

```
FROM MAP-CommonDataTypes
```

```
{ccitt(0) identified-Organisation (4) etsi(0) mobileDomain(0)  
gsmNetworkId(1) moduleId(3) MAP-commonDataTypes(18) version2(2)}  
BasicServiceId, SsId
```

```
FROM GSM-12-02-SYNTAX
```

```
{ccitt (0) identified-organisation(4) etsi(0) mobileDomain(0)  
gsm-Operation-Maintenance(3) gsm-12-02 (2) informationModel(0)  
asn1Module(2) 1}
```

```
;
```

```
-- Object Identifiers
```

```
-- Abstract Syntax
```

```
gsm1200AabstractSyntax      OBJECT IDENTIFIER ::=  
    {gsm-12-00A abstractSyntax (1)}
```

```
-- Information Model Related Identifiers
```

```
gsm1200AinformationModel  OBJECT IDENTIFIER ::=  
    {gsm-12-00A informationModel (0)}
```

```
gsm1200AmanagedObjectClass OBJECT IDENTIFIER ::=  
    {gsm1200AinformationModel managedObjectClass (3)}
```

```
gsm1200Apackage           OBJECT IDENTIFIER ::=  
    {gsm1200AinformationModel package (4)}
```

```
gsm1200AnameBinding       OBJECT IDENTIFIER ::=  
    {gsm1200AinformationModel nameBinding (6)}
```

```
gsm1200Aattribute        OBJECT IDENTIFIER ::=  
    {gsm1200AinformationModel attribute (7)}
```

```
gsm1200Aaction           OBJECT IDENTIFIER ::=  
    {gsm1200AinformationModel action (9)}
```

```
gsm1200Anotification     OBJECT IDENTIFIER ::=  
    {gsm1200AinformationModel notification (10)}
```

```
-- Application Context Identifier
```

```
gsm1200AapplicationContext OBJECT IDENTIFIER ::=  
    {gsm-12-00A protocolSupport (1) applicationContext (0) gsm-Management (0)}
```

```
-- ASN1 definitions

AucFunctionId      ::= INTEGER

BssFunctionId      ::= INTEGER

Cc                 ::= GraphicString
SetOfCc            ::= SET OF Cc

EirFunctionId      ::= INTEGER
EirId              ::= GraphicString
EirNumber          ::= GraphicString

HlrFunctionId      ::= INTEGER

ListOfSupportedBS  ::= SET OF BasicServiceId
ListOfSupportedSS  ::= SET OF SsId

Mcc                ::= GraphicString
Mnc                ::= GraphicString
MscFunctionId      ::= INTEGER
MscId              ::= GraphicString
MscNumber          ::= ISDN-AddressString

Ndc                ::= GraphicString
SetOfNdc           ::= SET OF Ndc

SmsGIWFunctionId  ::= INTEGER

VlrFunctionId      ::= INTEGER
VlrId              ::= GraphicString
VlrNumber          ::= ISDN-AddressString

END
```

Annex B (normative): Definition of Common Management Functions

The GSM 12-series provides a definition of the information exchange between OSFs and NEFs for the purpose of management of a GSM network. Some of the management functions necessary to support the requirements of the defined Management Services are common to more than one Management Service. This Annex contains normative information on these common functions.

B.1 Description of Common Management Services

The following subclauses describe the Management Services which are found to be common across multiple application requirements.

B.1.1 Forwarding of Event Reports

Managed Object Classes have been defined to emit event notifications using standard notification types. It is a requirement that the forwarding of these event reports from the NE can be managed by the OS in a consistent manner.

This requirement is to be satisfied by the use of the Event Report Systems Management Function as defined by CCITT X.734 (ISO/IEC 10164 part 5 [16]). This definition uses the object class "eventForwardingDiscriminator" (EFD) to provide the management of the forwarding of event reports. No GSM specific modifications to the generic object class are proposed.

Each application which wishes to use the "eventForwardingDiscriminator" object class will have to define the specific operation, including the definition of allowable discriminator constructs, the event reports to which the discriminator construct applies, error conditions, the potential for multiple discriminator constructs to be applied to the same event notification type, etc.

B.1.2 Information Logging

Notifications generated by the managed objects are required to be held locally for subsequent retrieval and/or for data security reasons. It is also required that this data can be accessed by the OS in a controlled and consistent manner across multiple applications. The data so retained by the NE shall be able to be retrieved either selectively or in bulk.

This requirement is to be satisfied by the use of the standard Log Control Systems Management Function defined by CCITT X.735 (ISO/IEC 10164 part 6 [17]). Among other features, this Management Function allows the OS to control the logging of selective event notifications through a discriminator construct, and provides the OS with information on the status of the log (e.g. through the generation of alarms when the content of the log exceeds a pre-defined threshold). Specific instances of logs may be created with a defined discriminator construct so as to log a defined type of record, all records to be logged may be collected in a single log instance, or a combination of the two approaches may be adopted in order to satisfy the operational needs.

The definition of the structure of Log records which do not conform to the standard notification types defined by CCITT will have to be defined by the specific application. Application documents shall also describe specific error handling.

B.1.3 Bulk Data Transfer between the OS and the NE

It is seen to be a requirement that, when the transfer of large volumes of data between the OS and the NE is expected, it should be performed using the most appropriate method. Message transfer between the manager and the agent, in either direction, uses the CMISE service element functionality. Depending on the volume of data to be transferred, CMISE may be seen to be the best method.

However, it is a requirement that when the use of CMISE services for the transfer of the data is not appropriate then data can be transferred as a file using the services of FTAM (see GSM 12.01 for more information on FTAM and its available services). FTAM can also be used for the transfer of data which may not be directly visible on the management interface and, therefore, not available for transfer using CMISE services.

Three scenarios for the use of FTAM for the transfer of large volumes of data are defined:

- 1) transfer of data from the NE to the OS requested by the OS;
- 2) transfer of data from the NE to the OS requested by the NE; and,
- 3) transfer of data from the OS to the NE requested by the OS.

The sequences of events which characterise these scenarios are described pictorially in Figure 18/12.00.

NOTE: In each case the control of the data transfer remains with the managing OS. The control of the data transfer is managed through the exchange of messages containing information on the data transfer required using CMISE services. This technique is to be known as "the CMISE control of FTAM file transfer" for convenience. This control is exercised through the object class "simpleFileTransferControl". All elements of the procedure can be correlated by means of a unique identifier ('transferId') that is included in any of the CMISE messages defined for the CMISE control of FTAM file transfer.

B.1.3.1 Transfer of data from the NE to the OS requested by the OS

The following options for the transfer of bulk data from the NE to the OS on request of the OS have been identified:

- the OS requires to read a file stored in the NE;
- it is required to transfer selected data stored in the NE in a log (using selection criteria to create one or more files from the log contents) in bulk form; and,
- it is required to transfer selected data concerning managed object instances in bulk form.

The request from the OS to the NE is in the form of a "requestTransferUp" Action which contains the parameter "resultType" as the indicator of the transfer option to be used and to indicate to the NE the processing required to create one or more files, as necessary. When all the related files are ready to be transferred then the NE emits a "transferUpReady" notification containing the file identifiers. The OS can then read the files using the FTAM Read service. At the end of the transfer the OS informs the NE through the "transferUpReceived" Action. (Full details of these Actions and Notifications can be found in the GDMO definitions.) Subsequent management of the files at source is a matter for local implementation.

If the choice "objectSelection" in "ResultType" is chosen then it is required that the "ObjectDataFile" file type is used as the format of the transferred data. The combination forms a generic function for retrieval of information of managed objects from a NE using the bulk data transfer function.

B.1.3.2 Transfer of Data from the NE to the OS requested by the NE

When the normal operation of the NE includes the creation of files containing data which needs to be transferred to the OS then the NE will inform the OS of the existence of the files by means of the "transferUpReady" notification which will contain the file identifier(s) of the file(s) ready for retrieval. The OS will then be responsible for retrieving the file(s) using the FTAM Read service. When the file(s) has been retrieved then the OS informs the NE through the "transferUpReceived" Action. (Full details of these Actions and Notifications can be found in the GDMO definitions.) Subsequent management of the file(s) at source is a matter for local implementation.

B.1.3.3 Transfer of Data from the OS to the NE requested by the OS

Two types of requirements for this form of file transfer have been recognised:

- transfer of bulk data for use by the NE (an example may be loadable software); and,
- the transfer of multiple managed object manipulation commands (an example is the bulk transfer of updates from a Central EIR to individual EIRs for IMEI management).

The NE is prepared by the OS to receive the file transfer through the "requestTransferDown" Action to which the NE responds with a "transferDownReady" notification when it is prepared to accept the transfer. The transfer is then performed by the OS using the FTAM Write service. When the transfer is complete the OS informs the NE of the transferred files through the "transferDownComplete" Action. (Full details of these

Actions and Notifications can be found in the GDMO definitions.) Subsequent management of the files at source will be a matter for local implementation.

B.1.3.4 Error conditions

The following general error conditions, additional to existing CMIP errors, have been identified in association with the CMISE control of FTAM file transfer. Application specific error conditions which may occur during the execution of this procedure shall be defined in the specific application document.

- a) NE unable to process the "requestTransferUp" Action request.
An appropriate failure confirmation to the Action request will be generated; the file transfer process will be terminated by the agent.
- b) Error on confirmation of "transferUpReady" Notification.
The file transfer process will be terminated. Recovery from the failure is outside of the scope of this standard.
- c) Error occurs during file preparation following a request from the OS.
The NE will generate a "bulkTransferError" notification with an appropriate "probableCause" value. If the value of the "perceivedSeverity" of the notification is equal to "warning" or "minor" then the procedure will continue and the file will be produced, despite the error. If the value of the "perceivedSeverity" is equal to "major", "critical" or "indeterminate" the procedure shall be terminated. The failure Notification shall contain the identifier associated with the respective "requestTransferUp" Action request (transferId).
- d) The number of files read is not equal to the number of files made available for transfer.
The procedure should be re-tried for those files not successfully transferred. The number of re-try attempts will be a matter for local implementation.
- e) NE unable to process the "requestTransferDown" Action request.
An appropriate failure confirmation to the Action request will be generated; the file transfer process will be terminated.
- f) Error occurs in the NE after positive confirmation of the "requestTransferDown" Action request. The NE shall generate a "bulkTransferError" notification. This notification shall contain the identifier associated with the respective "requestTransferDown" Action request (transferId).
- g) OS sends an error response to the "transferDownReady" notification.
The file transfer process will be terminated. It will be up to the OS to decide on a re-try.
- h) The number of files written is not equal to the number of files made available for transfer.
The procedure should be re-tried for those files not successfully transferred. The number of re-try attempts will be a matter for local implementation.
- i) The NE has problems processing a file which has been received.
This is an application specific area and shall be described in the application specification documents.

1. Up Load Case: Initiated by OS or NE; Read by OS

The two scenarios are described using the same diagram below.

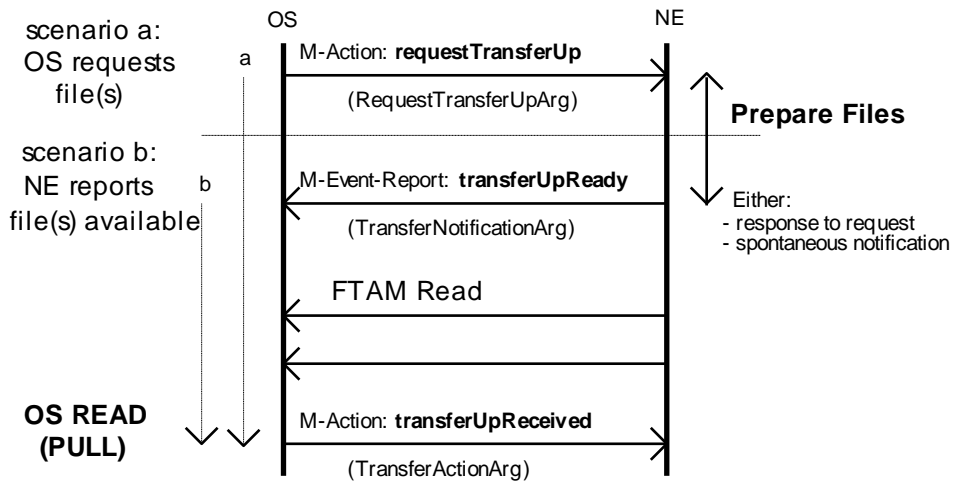

2. Down Load Case: Initiated by OS; Written by OS

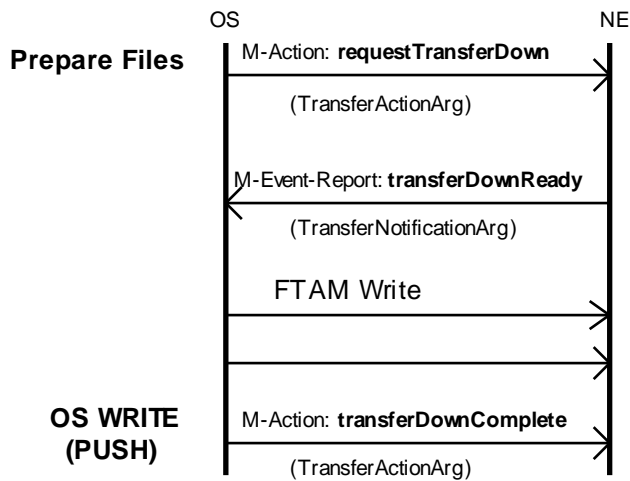

Figure 18/12.00: Message Scenarios For Upload And Download

B.2 GDMO definitions for Common Management Functions

The following subclauses contain the definitions, in GDMO format, for those aspects of the common management functions which are defined for GSM. References are provided where the common management functions use definitions to be imported from other standards.

B.2.1 MANAGED OBJECT CLASSES

B.2.1.1 simpleFileTransferControl

```
simpleFileTransferControl MANAGED OBJECT CLASS
  DERIVED FROM
    "Recommendation X.721: 1992": top;
  CHARACTERIZED BY
    simpleFileTransferControlBasicPackage;
  CONDITIONAL PACKAGES
    dataTransferUploadControlPackage
      PRESENT IF "it is required to upload files using FTAM from a
        managed element",
    dataTransferDownloadControlPackage
      PRESENT IF "it is required to download files using FTAM to a
        managed element";
REGISTERED AS {gsm1200BmanagedObjectClass 10};
```

B.2.1.2 generalDataTransferControlFunction

```
generalDataTransferControlFunction MANAGED OBJECT CLASS
  DERIVED FROM
    "Recommendation X.721: 1992": top;
  CHARACTERIZED BY
    generalDataTransferControlFunctionPackage;
REGISTERED AS {gsm1200BmanagedObjectclass 20};
```

B.2.1.3 Recommendation X.721: 1992 alarmRecord

Objects of this class are used to represent logged information that resulted from Alarm Notifications.

B.2.1.4 Recommendation X.721: 1992 attributeValueChangeRecord

Objects of this class are used to represent logged information that resulted from Attribute Value Change Notifications.

B.2.1.5 Recommendation X.721: 1992 eventForwardingDiscriminator

The semantics of this managed object class are defined in ISO 10164-5/Recommendation X.734.

B.2.1.6 Recommendation X.721: 1992 log

The semantics of this managed object class are defined in ISO 10164-6/Recommendation X.735.

B.2.1.7 Recommendation X.721: 1992 objectCreationRecord

Objects of this class are used to represent logged information that resulted from Object Creation Notifications.

B.2.1.8 Recommendation X.721: 1992 objectDeletionRecord

Objects of this class are used to represent logged information that resulted from Object Deletion Notifications.

B.2.1.9 Recommendation X.721: 1992 stateChangeRecord

Objects of this class are used to represent logged information that resulted from state change notifications.

B.2.1.10 transferReadyRecord

Objects of this class are used to represent logged information that resulted from either transferUpReady or transferDownReady notifications.

```
transferReadyRecord MANAGED OBJECT CLASS  
  DERIVED FROM  
    "Recommendation X.721: 1992": eventLogRecord;  
  -- The identifier values for the eventType attribute inherited from eventLogRecord  
  -- shall be either transferUpReady or transferDownReady.  
  CHARACTERIZED BY  
    transferNotificationArgPackage;  
RESIGTERED AS {gsm1200BmanagedObjectClass 30};
```

B.2.1.11 bulkTransferErrorRecord

Objects of this class are used to represent logged information that resulted from bulkTransferError notifications.

```
bulkTransferErrorRecord MANAGED OBJECT CLASS  
  DERIVED FROM  
    "Recommendation X.721: 1992": alarmRecord;  
  -- The identifier values for the eventType attribute inherited from eventLogRecord  
  -- shall be bulkTransferError.  
  CHARACTERIZED BY  
    bulkTransferErrorPackage;  
RESIGTERED AS {gsm1200BmanagedObjectClass 40};
```

B.2.2 Package definitions

B.2.2.1 dataTransferUploadControlPackage

dataTransferUploadControlPackage **PACKAGE**

BEHAVIOUR

dataTransferUploadControlBehaviour **BEHAVIOUR**

DEFINED AS

"This package provides the Actions and Notifications for the control of the upload procedure of the simple FTAM file Transfer (see appropriate Action and Notification definitions).

On receipt of the Action 'requestTransferUp' the requested information will be prepared for transfer to the OSF in the form of one or more FTAM files. Once preparations are complete the object will issue a 'transferUpReady' Notification. The OSF informs the Managed Element (ME) that the files have been successfully transferred using the Action 'transferUpReceived'.

An unsolicited 'transferUpReady' Notification may be emitted by the object

- to inform the OSF that one or more file(s) the ME has generated without a request from the OSF (e.g. call records) are ready for transfer or
- to notify the OSF if the filestore is full and that it should read the files before the ME may eventually be forced to overwrite previously collected data.

If, upon receipt of the 'requestTransferUp' Action, the ME is unable to process the OSF's request, this shall be indicated in the Action response (failure response). If, after acknowledgement of the 'requestTransferUp' Action, problems with respect to the preparation/formatting of the file(s) occur within the ME (e.g. the files cannot be compiled due to internal resource limitation), the object will issue a bulkTransferError notification with the appropriate probable cause value."

;;

ACTIONS

requestTransferUp, -- 1st message
transferUpReceived; -- 3rd message

NOTIFICATIONS

transferUpReady, -- 2nd message
bulkTransferError;

RESIGTERED AS {gsm1200Bpackage 10};

B.2.2.2 dataTransferDownloadControlPackage

dataTransferDownloadControlPackage **PACKAGE**

BEHAVIOUR

dataTransferDownloadControlBehaviour **BEHAVIOUR**

DEFINED AS

"This package provides the Actions and Notifications for the control of the download procedure of the simple FTAM file Transfer (see appropriate Action and Notification definitions).

In the case of an OS initiated download, the OSF will indicate to the ME with the 'requestTransferDown' Action that one or more files have been prepared for transfer to the ME.

When ready to receive the file(s) then the ME answers with a 'transferDownReady' Notification.

The OSF can then transfer the file(s) using FTAM write. When the file transfer is complete the OSF sends a 'transferDownComplete' Action to the ME to indicate that processing of the file contents may now begin. The file(s) can then be deleted by the OSF.

If the ME, upon receipt of the Action 'requestTransferDown', is unable to process the OSF's request, this shall be indicated in an appropriate failure response to the Action. If there are problems before the file transfer to the ME once the 'requestTransferDown' Action has been acknowledged, the object will issue a 'bulkTransferError' Notification to the OSF, with the appropriate probable cause value.";

ACTIONS

requestTransferDown, -- 1st message
transferDownComplete; -- 3rd message

NOTIFICATIONS

transferDownReady, -- 2nd message
bulkTransferError;

RESIGTERED AS {gsm1200Bpackage 20};

B.2.2.3 generalDataTransferControlFunctionPackage

```
generalDataTransferControlFunctionPackage PACKAGE
  BEHAVIOUR
    generalDataTransferControlFunctionBehaviour BEHAVIOUR
  DEFINED AS
    "This object class is used to model common properties of a general data transfer control
    function of a Managed Element. Its purpose is to represent a top level data transfer
    function in which various objects that may be defined independently for specific data
    transfer control (e.g. simple FTAM file transfer) can be contained.
    One instance of this class is contained in a Managed Element if it is required to
    transfer data between the OSF and one or more NEFs contained in the Managed Element. This
    object is identified by the value of the Attribute
    'generalDataTransferControlFunctionId'."
  ;;
  ATTRIBUTES
    generalDataTransferControlFunctionId GET;
  NOTIFICATIONS
    "Recommendation X.721: 1992": objectCreation,
    "Recommendation X.721: 1992": objectDeletion;
  REGISTERED AS {gsm1200Bpackage 30};
```

B.2.2.4 simpleFileTransferControlBasicPackage

```
simpleFileTransferControlBasicPackage PACKAGE
  BEHAVIOUR
    simpleFileTransferControlBasicBehaviour BEHAVIOUR
  DEFINED AS
    "This object class represents the facilities to control simple file transfer from the OSF
    to a NEF that is contained in the same Managed Element as this object, and vice versa.
    One instance of this class shall be contained in the appropriate
    'generalDataTransferControlFunction' object if simple file transfer is required. This
    object is identified by the value of the Attribute 'simpleFileTransferControlId'."
  ;;
  ATTRIBUTES
    simpleFileTransferControlId GET;
  NOTIFICATIONS
    "Recommendation X.721: 1992": objectCreation,
    "Recommendation X.721: 1992": objectDeletion;
  REGISTERED AS {gsm1200Bpackage 40};
```

B.2.2.5 transferNotificationArgPackage

```
transferNotificationArgPackage PACKAGE
  BEHAVIOUR
    transferNotificationArgPackageBehaviour BEHAVIOUR
  DEFINED AS
    "This package provides the attributes for storing the contents of transferUpReady and
    transferDownReady notifications on the log as eventLogRecords."
  ;;
  ATTRIBUTES
    fileListValues GET,
    linkedTransferIdValue GET,
    transferIdValue GET;
  REGISTERED AS {gsm1200Bpackage 50};
```

B.2.2.6 bulkTransferErrorPackage

bulkTransferErrorPackage **PACKAGE**

BEHAVIOUR

bulkTransferErrorPackageBehaviour **BEHAVIOUR**

DEFINED AS

"This package provides the attributes for storing the contents of bulkTransferError notifications on the log as a subclass of alarmRecords."

;;

ATTRIBUTES

transferIdValue **GET;**

REGISTERED AS {gsm1200Bpackage 60};

B.2.3 Attribute Definitions

B.2.3.1 generalDataTransferControlFunctionId

```
generalDataTransferControlFunctionId ATTRIBUTE  
  WITH ATTRIBUTE SYNTAX  
    GSM1200BTypeModule.GeneralDataTransferControlFunctionId;  
  BEHAVIOUR  
    generalDataTransferControlFunctionIdBehaviour;  
REGISTERED AS {gsm1200Battribute 10};
```

```
generalDataTransferControlFunctionIdBehaviour BEHAVIOUR  
  DEFINED AS
```

"This attribute names a 'generalDataTransferControlFunction' object. Apart from providing a unique identifier, the value does not have any other specific semantics."
;

B.2.3.2 simpleFileTransferControlId

```
simpleFileTransferControlId ATTRIBUTE  
  WITH ATTRIBUTE SYNTAX  
    GSM1200BTypeModule.SimpleFileTransferControlId;  
  BEHAVIOUR  
    simpleFileTransferControlIdBehaviour;  
REGISTERED AS {gsm1200Battribute 20};
```

```
simpleFileTransferControlIdBehaviour BEHAVIOUR  
  DEFINED AS
```

"This attribute names a 'simpleFileTransferControl' object. Apart from providing a unique identifier, the value does not have any other specific semantics.";

B.2.3.3 fileListValues

```
fileListValues ATTRIBUTE  
  WITH ATTRIBUTE SYNTAX  
    GSM1200BTypeModule.FileList;  
  MATCHES FOR EQUALITY, SET-COMPARISON, SET-INTERSECTION;  
  BEHAVIOUR  
    fileListValuesBehaviour;  
REGISTERED AS {gsm1200Battribute 30};
```

```
fileListValuesBehaviour BEHAVIOUR  
  DEFINED AS
```

"This attribute represents the contents of the fileList field of a transferUpReady or transferDownReady notification.";

B.2.3.4 linkedTransferIdValue

```
linkedTransferIdValue ATTRIBUTE  
  WITH ATTRIBUTE SYNTAX  
    GSM1200BTypeModule.LinkedTransferId;  
  MATCHES FOR EQUALITY;  
  BEHAVIOUR  
    linkedTransferIdValueBehaviour;  
REGISTERED AS {gsm1200Battribute 40};
```

```
linkedTransferIdValueBehaviour BEHAVIOUR  
  DEFINED AS
```

"This attribute represents the value of linkedTransferId to be used. e.g. for filtering purposes.";

B.2.3.5 transferIdValue

```
transferIdValue ATTRIBUTE  
  WITH ATTRIBUTE SYNTAX  
    GSM1200BTypeModule.TransferId;
```

MATCHES FOR EQUALITY, ORDERING;

BEHAVIOUR

transferIdValueBehaviour;

REGISTERED AS {gsm1200Battribute 50};

transferIdValueBehaviour **BEHAVIOUR**

DEFINED AS

"This attribute represents the value of transferId to be used. e.g. for filtering purposes.";

B.2.4 ACTIONS

B.2.4.1 requestTransferUp

requestTransferUp **ACTION**

BEHAVIOUR

requestTransferUpBehaviour **BEHAVIOUR**

DEFINED AS

"This Action is used to request the preparation of data for subsequent transfer via FTAM services. In some cases the data may already exist in the form of one or more files. For other applications the files must first be produced or formatted for transfer to the OSF. If the request from the OSF can be accepted, a success response shall be generated by the object. If, upon receipt of the 'requestTransferUp' Action, the Managed Element is unable to process the OSF's request, this shall be indicated in the Action response with the appropriate error indication set.

The RequestTransferUpArg argument of the syntax contains the following parameters:

- 1 FileType: the type of requested information
- 2 FileSubType: optionally, additional information to specify a specific file; or
- 3 objectSelection: allows the OS to request information about any managed object. The file type will be determined by the NE on a case by case basis.
- 4 transferId: the parameter that identifies the group of CMIP operations that together form the control for one bulk data transfer between OS and NE.

";;

MODE CONFIRMED;

WITH INFORMATION SYNTAX GSM1200BTypeModule.RequestTransferUpArg;

RESIGTERED AS {gsm1200Baction 10};

B.2.4.2 transferUpReceived

transferUpReceived **ACTION**

BEHAVIOUR

transferUpReceivedBehaviour **BEHAVIOUR**

DEFINED AS

"This Action is used to inform the Managed Element that one or more FTAM files have been successfully transferred. The files transferred may then be deleted and allocated resources be freed. The 'FileList' in the 'ActionInfo' field of the PDU identifies the file(s) that have successfully been collected by the OSF.

The receipt of the Action will be acknowledged by the Managed Element in an appropriate success or error Action response.

The TransferActionArg argument of the syntax contains the following parameters:

- 1 fileName: name(s) of the file(s) that have been used by the FTAM services
- 2 fileType: the type of requested information
- 3 fileSubType: additional information to specify a file instance
- 4 fileSize: optional, file size in bytes
- 5 transferId: the parameter that identifies the group of CMIP operations that together form the control for one bulk data transfer between OS and NE.

";;

MODE CONFIRMED;

WITH INFORMATION SYNTAX GSM1200BTypeModule.TransferActionArg;

RESIGTERED AS {gsm1200Baction 20};

B.2.4.3 requestTransferDown

requestTransferDown **ACTION**

BEHAVIOUR

requestTransferDownBehaviour **BEHAVIOUR**

DEFINED AS

"This action is issued to inform the ME that data has been prepared for transfer from the OSF to the ME via FTAM services. This Action includes a list of one or more file names and file types and the file size can optionally be included.

A successful confirmation to this request indicates that the ME has accepted the request from the OSF to get ready to receive the file(s) to be transferred. An error confirmation indicates that the ME has refused the request at this point.

The TransferActionArg argument of the syntax contains the following parameters:

- 1 fileName: name(s) of the file(s) that shall be used by the FTAM services

```

2  fileType:      the type of requested information
3  fileSubType:  additional information to specify a file instance
4  fileSize:     optional, file size in bytes
5  transferId:   the parameter that identifies the group of CMIP operations that
together form the control for one bulk data transfer between OS and NE.
";
  MODE CONFIRMED;
  WITH INFORMATION SYNTAX GSM1200BTypeModule.TransferActionArg;
REGISTERED AS {gsm1200Baction 30};

```

B.2.4.4 transferDownComplete

transferDownComplete **ACTION**

BEHAVIOUR

transferDownCompleteBehaviour **BEHAVIOUR**

DEFINED AS

"This Action is used to inform the NE that one or more FTAM files have been successfully transferred. When this Action is confirmed without error by the NE, the transferred files may be deleted in the OSF. The file list, the type of file and optionally the file size are included in this Action.

The TransferActionArg argument of the syntax contains the following parameters:

```

1  fileName:     name(s) of the file(s) that have been transferred by the FTAM services
2  fileType:     the type of requested information
3  fileSubType:  additional information to specify a file instance
4  fileSize:     optional, file size in bytes
5  transferId:   the parameter that identifies the group of CMIP operations that
together form the control for one bulk data transfer between OS and NE.
";

```

MODE CONFIRMED;

WITH INFORMATION SYNTAX GSM1200BTypeModule.TransferActionArg;

REGISTERED AS {gsm1200Baction 40};

B.2.5 NOTIFICATIONS

B.2.5.1 transferUpReady

transferUpReady **NOTIFICATION**

BEHAVIOUR

transferUpReadyBehaviour **BEHAVIOUR**

DEFINED AS

"This Notification is issued by the object to indicate that one or more FTAM files are now ready for transfer from the ME to the OSF. The 'FileList' contained in the 'EventInfo' field of the PDU identifies the file(s) that have been prepared for OSF read. The TransferNotificationArg of the syntax contains the following parameters:

- 1 fileName: name(s) of the file(s) that shall be used by the FTAM services
- 2 fileType: the type of requested information
- 3 fileSubType: additional information to specify a file instance
- 4 fileSize: optional, file size in bytes
- 5 linkedTransferId: BOOLEAN data type that indicates whether the notification is linked to a requestTransferUp action via a transferId parameter
- 6 transferId: the parameter that identifies the group of CMIP operations that together form the control for one bulk data transfer between OS and NE.

;;

WITH INFORMATION SYNTAX GSM1200BTypeModule.TransferNotificationArg;

RESIGTERED AS {gsm1200Bnotification 10};

B.2.5.2 bulkTransferError

bulkTransferError **NOTIFICATION**

BEHAVIOUR

bulkTransferErrorBehaviour **BEHAVIOUR**

DEFINED AS

"This notification informs the OS that a processing error in the NE has occurred while preparing the FTAM files for subsequent transfer to the OS. The notification contains the following parameters:

- 1 transferId: the parameter that identifies the group of CMIP operations that together form the control for one bulk data transfer between OS and NE in the case of a previous requestTransferUp action.
- 2 fields of alarmInfo: as defined in CCITT X.721

;;

WITH INFORMATION SYNTAX GSM1200BTypeModule.BulkTransferError;

AND ATTRIBUTE IDS

transferId	transferIdValue,
-- Following attribute	Ids are from X.721:processingErrorAlarm
probableCause	"Recommendation X.721:1992":probableCause,
specificProblems	"Recommendation X.721:1992":specificProblems,
perceivedSeverity	"Recommendation X.721:1992":perceivedSeverity,
backedUpStatus	"Recommendation X.721:1992":backedUpStatus,
backUpObject	"Recommendation X.721:1992":backUpObject,
trendIndication	"Recommendation X.721:1992":trendIndication,
thresholdInfo	"Recommendation X.721:1992":thesholdInfo,
notificationIdentifier	"Recommendation X.721:1992":notificationIdentifier,
correlatedNotifications	"Recommendation X.721:1992":correlatedNotifications,
stateChangeDefinition	"Recommendation X.721:1992":stateChangeDefinition,
monitoredAttributes	"Recommendation X.721:1992":monitoredAttributes,
proposedRepairActions	"Recommendation X.721:1992":proposedRepairActions,
additionalText	"Recommendation X.721:1992":additionalText,
additionalInformation	"Recommendation X.721:1992":additionalInformation;

RESIGTERED AS {gsm1200Bnotification 20};

B.2.5.3 transferDownReady

transferDownReady **NOTIFICATION**

BEHAVIOUR

transferDownReadyBehaviour **BEHAVIOUR**

DEFINED AS

"This Notification is issued to indicate in the case of an OSF triggered download that the ME is now ready to receive the data to be transferred from the OSF via FTAM services.

The file list, the type of file and optionally the file size are included in this Notification.

The TransferNotificationArg of the syntax contains the following parameters:

- 1 fileName: name(s) of the file(s) that shall be used by the FTAM services
- 2 fileType: the type of requested information
- 3 fileSubType: additional information to specify a specific file
- 4 fileSize: optional, file size in bytes
- 5 linkedTransferId: BOOLEAN data type that indicates that the notification is linked to a requestTransferDown action via a transferId parameter. Its value shall always be 'True'.
- 6 transferId: the parameter that identifies the group of CMIP operations that together form the control for one bulk data transfer between OS and NE.

```
"";  
WITH INFORMATION SYNTAX GSM1200BTypeModule.TransferNotificationArg;  
RESIGTERED AS {gsm1200Bnotification 30};
```

B.2.6 NAME BINDINGS

B.2.6.1 generalDataTransferControlFunction-managedElement

```
NAME BINDING  
generalDataTransferControlFunction-managedElement NAME BINDING  
SUBORDINATE OBJECT CLASS generalDataTransferControlFunction;  
NAMED BY  
SUPERIOR OBJECT CLASS "Recommendation M.3100: 1992": managedElement;  
WITH ATTRIBUTE generalDataTransferControlFunctionId;  
BEHAVIOUR generalDataTransferControlFunction-managedElementBehaviour;  
CREATE ;  
DELETE ;  
RESIGTERED AS {gsm1200BnameBinding 10};  
generalDataTransferControlFunction-managedElementBehaviour BEHAVIOUR  
DEFINED AS  
"  
";
```

B.2.6.2 simplefileTransferControl-generalDataTransferControlFunction

```
NAME BINDING  
simpleFileTransferControl-generalDataTransferControlFunction NAME BINDING  
SUBORDINATE OBJECT CLASS simpleFileTransferControl;  
NAMED BY  
SUPERIOR OBJECT CLASS generalDataTransferControlFunction;  
WITH ATTRIBUTE simpleFileTransferControlId;  
BEHAVIOUR simpleFileTransferControl-generalDataTransferControlFunctionBehaviour;  
CREATE ;  
DELETE ;  
RESIGTERED AS {gsm 1200BnameBinding 20};  
  
simpleFileTransferControl-generalDataTransferControlFunctionBehaviour BEHAVIOUR  
DEFINED AS  
"  
".  
";
```

B.2.7 SYNTAX DEFINITIONS

```
GSM1200BTypeModule {ccitt (0) identified-organization (4) etsi (0) mobileDomain (0) gsm-  
Operation-Maintenance (3) gsm-12-00 (0) annexB (1) informationModel (0) asn1Module (2)  
version1 (1)}
```

```
DEFINITION IMPLICIT TAGS ::=
```

```
BEGIN
```

```
    IMPORTS
        gsm-12-00B
    FROM GSM-DomainDefinitions
        {ccitt (0) identified-organization (4) etsi (0) mobileDomain (0)
        gsm-Operation-Maintenance (3) gsm-12-30 (30) informationModel (0) asn1Module (2)
        gsm-OM-DomainDefinitions (0) version1 (1)}
        SimpleNameType
    FROM Attribute-ASN1Module { joint-isi-ccitt ms (9) smi (3) part2 (2) asn1Module (2)
1}
        GetArgument, GetResult
    FROM CMIP-1 {joint-iso-ccitt ms (9) cmip (1) modules (0) protocol (3)}
        AlarmInfo
    FROM Notification-ASN1Module
        {joint-iso-ccitt ms (9) smi (3) part2 (2) asn1Module (2) 2}
    ;

    -- Object Identifiers

    -- Abstract Syntax

gsm1200BabstractSyntax      OBJECT IDENTIFIER ::=
        {gsm-12-00B abstractSyntax (1)}

    -- Information Model Related Identifiers

gsm1200BinformationModel  OBJECT IDENTIFIER ::=
        {gsm-12-00B informationModel (0)}

gsm1200BmanagedObjectClass OBJECT IDENTIFIER ::=
        {gsm1200BinformationModel managedObjectClass (3)}

gsm1200Bpackage           OBJECT IDENTIFIER ::=
        {gsm1200BinformationModel package (4)}

gsm1200Bparameter        OBJECT IDENTIFIER ::=
        {gsm1200BinformationModel parameter (5)}

gsm1200BnameBinding       OBJECT IDENTIFIER ::=
        {gsm1200BinformationModel nameBinding (6)}

gsm1200Battribute         OBJECT IDENTIFIER ::=
        {gsm1200BinformationModel attribute (7)}

gsm1200Baction           OBJECT IDENTIFIER ::=
        {gsm1200BinformationModel action (9)}

gsm1200Bnotification     OBJECT IDENTIFIER ::=
        {gsm1200BinformationModel notification (10)}

    -- Application Context Identifier

gsm1200BapplicationContext OBJECT IDENTIFIER ::=
        {gsm-12-00B protocolSupport (1) applicationContext (0) gsm-Management (0)}
```

```
-- ASN1 definitions

BulkTransferError ::= SEQUENCE
{
  COMPONENTS OF AlarmInfo,
  transferId      TransferId
}

FileList ::= SET OF FileSpec

FileSpec ::= SEQUENCE
{
  fileName      [1] SimpleNameType,
  typeOfFile    [2] TypeOfFile,
  fileSize      [3] INTEGER OPTIONAL -- in bytes
}

FileSubType ::= INTEGER
--
-- this allows additional information on the individual types of records in the file
-- to be supplied by the agent.
-- For coding of subtypes, refer to individual applications, e.g. GSM 12.02.

FileType ::= INTEGER
{
  general          (0), -- structure undefined
  callRecords     (1), -- defined in GSM 12.05
  software        (2), -- structure undefined
  database        (3), -- structure undefined
  observedIMEITicket (4), -- defined in GSM 12.02
  securityRecords (5), -- to be defined in GSM 12.03
  testResults     (6), -- to be defined in GSM 12.11
  measurements    (7), -- containing scan reports
  configurationFile (8), -- objectDataFile structure
  traceRecords    (9), -- to be defined in GSM 12.08
  eirManagementFile (10), -- defined in GSM 12.02
  objectManagementRecords (11), -- objectDataFile structure
  stateChangeRecords (12), -- objectDataFile structure
  alarmRecords    (13) -- objectDataFile structure
}

-- There are no restrictions on the file types defined by general, software and database

GeneralDataTransferControlFunctionId ::= SimpleNameType

LinkedTransferId ::= BOOLEAN

ObjectDataFile ::= SEQUENCE
{
  productionDateTime [0] GeneralizedTime,
  objectData         [1] IMPLICIT SEQUENCE OF ObjectInfo
}

ObjectInfo ::= GetResult -- currentTime optional component not needed

ResultType ::= CHOICE
{
  typeOfFile [0] TypeOfFile,
  objectSelection [1] GetArgument -- can be used for getting deliberate
  selection
  -- of objects or retrieving log records
}

RequestTransferUpArg ::= SEQUENCE
{
  resultType ResultType,
  transferId TransferId
}
```

```
SimpleFileTransferControlId ::= SimpleNameType;

TransferActionArg ::= SEQUENCE
{
    fileList      FileList,
    transferId    TransferId
}

TransferId ::= INTEGER

TransferNotificationArg ::= SEQUENCE
{
    fileList      FileList,
    linkedTransferId BOOLEAN,
    transferId    TransferId
}

TypeOfFile ::= SEQUENCE
{
    fileType      [1] FileType,
    fileSubType   [2] FileSubType OPTIONAL
}

END
```

History

Document history			
August 1995	Public Enquiry	PE 89:	1995-08-07 to 1995-12-01
March 1996	Vote	V 100:	1996-03-25 to 1996-05-17
June 1996	First Edition		
December 1997	Incorporation of SMG #23 CR.		