

Source: SMG

Reference: DE/SMG-081124P

ICS: 33.020

Key words: Digital cellular telecommunications system, Global System for Mobile Communications (GSM)



**Digital cellular telecommunications system (Phase 2);
Base Station System (BSS) equipment specification;
Part 3: Transcoder aspects
(GSM 11.24 version 4.3.1)**

ETSI

European Telecommunications Standards Institute

ETSI Secretariat

Postal address: F-06921 Sophia Antipolis CEDEX - FRANCE

Office address: 650 Route des Lucioles - Sophia Antipolis - Valbonne - FRANCE

Internet: secretariat@etsi.fr - <http://www.etsi.org>

Tel.: +33 4 92 94 42 00 - Fax: +33 4 93 65 47 16

Copyright Notification: No part may be reproduced except as authorized by written permission. The copyright and the foregoing restriction extend to reproduction in all media.

© European Telecommunications Standards Institute 1999. All rights reserved.

Contents

Intellectual Property Rights	5
Foreword	5
Introduction.....	5
1 Scope.....	7
2 Normative references.....	7
3 Definitions and abbreviations	9
3.1 Definitions.....	9
3.2 Abbreviations	9
4 Transcoding and rate adaption	10
4.1 Transcoder test points	10
4.1.1 External interfaces.....	10
4.1.1.1 Test signals applied to the antenna connector	10
4.1.2 Internal test points and interfaces.....	11
5 Test descriptions for speech related transcoding function	17
5.1 Test descriptions for full rate speech related transcoding functions	17
5.1.1 Uplink tests.....	17
5.1.1.1 Uplink speech transcoding - 13 kbit/s to 104 kbit/s conversion.....	17
5.1.1.2 Uplink speech transcoding - 13 kbit/s to 16 kbit/s conversion.....	18
5.1.1.3 Uplink speech transcoding - 16 kbit/s to 104 kbit/s conversion.....	18
5.1.1.4 Uplink speech transcoding - 104 kbit/s to 64 kbit/s conversion.....	19
5.1.1.5 Uplink Speech Decoder - 13 kbit/s to 104 kbit/s conversion with DTX.....	20
5.1.1.6 Uplink Speech Decoder - 13 kbit/s to 16 kbit/s conversion with DTX.....	23
5.1.1.7 Uplink Speech Decoder - 16 kbit/s to 104 kbit/s conversion with DTX.....	24
5.1.2 Downlink tests.....	26
5.1.2.1 Downlink speech transcoding - 64 kbit/s to 104 kbit/s conversion.....	26
5.1.2.2 Downlink speech transcoding - 104 kbit/s to 13 kbit/s conversion.....	26
5.1.2.3 Downlink speech transcoding - 104 kbit/s to 16 kbit/s conversion.....	27
5.1.2.4 Downlink speech transcoding - 16 kbit/s to 13 kbit/s conversion.....	28
5.1.2.5 Downlink transmitter DTX/VAD functions - 104 kbit/s to 13 kbit/s level conversion with DTX.....	28
5.1.2.6 Downlink transmitter DTX/VAD functions - 104 kbit/s to 16 kbit/s conversion process	29
5.1.2.7 Downlink transmitter DTX/VAD functions - 16 kbit/s to 13 kbit/s conversion.....	30
5.2 Test descriptions for half rate speech related transcoding functions	31
5.3 Test descriptions for enhanced full rate speech related transcoding functions.....	31

5.4	Alternative use of the 64 kbit/s A-Interface for full, half and enhanced full rate speech transcoding tests.....	32
6	Test descriptions for full rate data rate adaption functions	32
6.1	Uplink rate adaptation data tests.....	33
6.1.1	Uplink rate adaptation, transparent data: radio rate to 64 kbit/s level.....	33
6.1.2	Uplink rate adaptation, transparent data - radio rate to 16kbit/s conversion... ..	34
6.1.3	Uplink rate adaption, transparent data: 16 kbit/s to 64 kbit/s	35
6.1.4	Uplink rate adaptation, non-transparent data: radio rates to 64 kbit/s	36
6.1.5	Uplink rate adaptation, non-transparent data: radio rate to 16kbit/s conversion.....	37
6.1.6	Uplink rate adaption, non-transparent data: 16 kbit/s to 64 kbit/s.....	38
6.2	Downlink rate adaptation data tests.....	39
6.2.1	Downlink rate adaptation, transparent data : 64 kbit/s to radio rates	39
6.2.2	Downlink rate adaptation, transparent data - 64 kbit/s to 16 kbit/s conversion.....	40
6.2.3	Downlink rate adaptation, transparent data: 16 kbit/s to radio rate	41
6.2.4	Downlink rate adaptation, non-transparent data: 64 kbit/s to radio rates conversion.....	42
6.2.5	Downlink rate adaptation, non-transparent data - 64 kbit/s to 16 kbit/s conversion.....	43
6.2.6	Downlink rate adaptation, non-transparent data: 16 kbit/s to radio rate.....	43
Annex A (informative):	Change history	45
History		46

Intellectual Property Rights

IPRs essential or potentially essential to the present document may have been declared to ETSI. The information pertaining to these essential IPRs, if any, is publicly available for **ETSI members and non-members**, and can be found in SR 000 314: "*Intellectual Property Rights (IPRs); Essential, or potentially Essential, IPRs notified to ETSI in respect of ETSI standards*", which is available **free of charge** from the ETSI Secretariat. Latest updates are available on the ETSI Web server (<http://www.etsi.org/ipr>).

Pursuant to the ETSI IPR Policy, no investigation, including IPR searches, has been carried out by ETSI. No guarantee can be given as to the existence of other IPRs not referenced in SR 000 314 (or the updates on the ETSI Web server) which are, or may be, or may become, essential to the present document.

Foreword

This European Telecommunication Standard (ETS) has been produced by the Special Mobile Group (SMG) Technical Committee of the European Telecommunications Standards Institute (ETSI).

This European Telecommunication Standard (ETS) describes the tests for transcoding functions within the digital cellular telecommunications system (Phase 2).

The contents of this ETS is subject to continuing work within SMG and may change following formal SMG approval. Should SMG modify the contents of this ETS, it will be resubmitted for OAP by ETSI with an identifying change of release date and an increase in version number as follows:

Version 4.x.y

where:

- 4 indicates GSM Phase 2;
- x the second digit is incremented for all changes of substance, i.e. technical enhancements, corrections, updates, etc.
- y the third digit is incremented when editorial only changes have been incorporated in the specification.

Transposition dates	
Date of adoption of this ETS:	22 January 1999
Date of latest announcement of this ETS (doa):	30 April 1999
Date of latest publication of new National Standard or endorsement of this ETS (dop/e):	31 October 1999
Date of withdrawal of any conflicting National Standard (dow):	31 October 1999

Introduction

This ETS contains the test specifications relating to the speech and transcoding aspects of a Base Station System (BSS). It provides a means to ensure that the BSS operates in accordance with the core specifications defined for GSM phase 2.

This ETS is a guide for manufacturers and users of GSM equipment and provides a common basis for the characterization of the relevant system operational aspects.

Blank page

1 Scope

This European Telecommunication Standard (ETS) specifies the testing requirements and methods for GSM 900 and DCS 1800 Base Station Systems.

Unless otherwise specified, references to GSM also includes DCS1800.

This test specification covers the following functions in the BSS:

- definition of test points;
- speech coding/decoding;
- data rate adaption;
- speech and data transcoding with DTX;
- control of remote TRAU.

The tests in this document are based on the full set of GSM phase 2 ETSs. In case of any inconsistency between this specification and the source specifications, the source specifications shall prevail.

2 Normative references

This ETS incorporates by dated and undated reference, provisions from other publications. These normative references are cited at the appropriate places in the text and the publications are listed hereafter. For dated references, subsequent amendments to or revisions of any of these publications apply to this ETS only when incorporated in it by amendment or revision. For undated references, the latest edition of the publication referred to applies.

- | | |
|------|---|
| [1] | ETR 100 (GSM 01.04): "Digital cellular telecommunication system (Phase 2); Abbreviations and acronyms". |
| [2] | ETS 300 557 (GSM 04.08): "Digital cellular telecommunication system (Phase 2); Mobile radio interface layer 3 specification". |
| [3] | ETS 300 562 (GSM 04.21): "Digital cellular telecommunication system (Phase 2); Rate adaption on the Mobile Station - Base Station System (MS - BSS) interface". |
| [4] | ETS 300 574 (GSM 05.02): "Digital cellular telecommunication system (Phase 2); Multiplexing and multiple access on the radio path". |
| [5] | ETS 300 575 (GSM 05.03): "Digital cellular telecommunication system (Phase 2); Channel coding". |
| [6] | ETS 300 578 (GSM 05.08): "Digital cellular telecommunication system (Phase 2); Radio subsystem link control". |
| [7] | ETS 300 580-1 (GSM 06.01): "Digital cellular telecommunication system (Phase 2); Full rate speech processing functions". |
| [8] | ETS 300 580-2 (GSM 06.10): "Digital cellular telecommunication system (Phase 2); Full rate speech transcoding". |
| [9] | ETS 300 580-3 (GSM 06.11): "Digital cellular telecommunication system (Phase 2); Substitution and muting of lost frames for full rate speech channels". |
| [10] | ETS 300 580-4 (GSM 06.12): "Digital cellular telecommunication system (Phase 2); Comfort noise aspect for full rate speech traffic channels". |
| [11] | ETS 300 580-5 (GSM 06.31): "Digital cellular telecommunication system (Phase 2); Discontinuous Transmission (DTX) for full rate speech traffic channel". |

- [12] ETS 300 580-6 (GSM 06.32): "Digital cellular telecommunication system (Phase 2); Voice Activity Detection (VAD)".
- [13] ETS 300 591 (GSM 08.20): "Digital cellular telecommunications system (Phase 2); Rate adaption on the Base Station System -Mobile- services Switching Centre (BSS - MSC) interface".
- [14] ETS 300 593 (GSM 08.52): "Digital cellular telecommunication system (Phase 2); Base Station Controller - Base Transceiver Station (BSC - BTS) interface; Interface principles".
- [15] ETS 300 594 (GSM 08.54): "Digital cellular telecommunication system (Phase 2); Base Station Controller - Base Transceiver Station (BSC - BTS) interface; Layer 1 structure of physical circuits".
- [16] ETS 300 596 (GSM 08.58): "Digital cellular telecommunications system (Phase 2); Base Station Controller - Base Transceiver Station (BSC -BTS) interface Layer 3 specification".
- [17] ETS 300 597 (GSM 08.60): "Digital cellular telecommunications system (Phase 2); Inband control of remote transcoders and rate adaptors for full rate traffic channels".
- [18] ETS 300 607-1 (GSM 11.10-1): "Digital cellular telecommunications system (Phase 2); Mobile Station (MS) conformance specification; Part 1: Conformance specification".
- [19] ETS 300 609-1 (GSM 11.21): "Digital cellular telecommunications system (Phase 2); Base Station System (BSS) equipment specification; Part 1: Radio aspects".
- [20] ITU-T Recommendation I.460: "Multiplexing, rate adaption and support of existing interfaces".
- [21] ITU-T Recommendation V.110: "Support of data terminal equipments with V-Series type interfaces by an integrated services digital network".
- [22] ETS 300 581-1 (GSM 06.02): "Digital cellular telecommunication system (Phase 2); Half Rate speech; Part 1: Half rate speech processing functions".
- [23] ETS 300 581-7 (GSM 06.06): Digital cellular telecommunications system; Half rate speech; Part 7: ANSI-C code for the GSM half rate speech codec".
- [24] ETS 300 581-8 (GSM 06.07): "Digital cellular telecommunication system (Phase 2); Half rate speech; Part 8: Test sequences for the GSM half rate speech codec".
- [25] ETS 300 581-2 (GSM 06.20): "Digital cellular telecommunication system (Phase 2); Half rate speech; Part 2: Half rate speech transcoding".
- [26] ETS 300 581-3 (GSM 06.21): "Digital cellular telecommunication system (Phase 2);Half rate speech; Part 3: Substitution and muting of lost frames for half rate speech channels".
- [27] ETS 300 581-4 (GSM 06.22): "Digital cellular telecommunication system (Phase 2); Half rate speech; Part 4: Comfort noise aspects for the half rate speech traffic channels".
- [28] ETS 300 581-5 (GSM 06.41): "Digital cellular telecommunication system (Phase 2);Half rate speech; Part 5: Discontinuous Transmission (DTX) for half rate speech traffic channel".

- [29] ETS 300 581-6 (GSM 06.42): "Digital cellular telecommunication system (Phase 2); Half rate speech; Part 6: Voice Activity Detection (VAD)".
- [30] ETS 300 598 (GSM 08.61): "Digital cellular telecommunications system (Phase 2); Inband control of remote transcoders and rate adaptors for half rate traffic channels".
- [31] ETS 300 725 (GSM 06.54): "Digital cellular telecommunications system (Phase 2); Test vectors for the GSM Enhanced Full Rate (EFR) speech codec".
- [32] ETS 300 723 (GSM 06.51): "Digital cellular telecommunications system; Enhanced Full Rate (EFR) speech coding functions; General description".
- [33] ETS 300 724 (GSM 06.53): "Digital cellular telecommunications system; ANSI-C code for the GSM Enhanced Full Rate (EFR) speech codec".
- [34] ETS 300 726 (GSM 06.60): "Digital cellular telecommunications system; Enhanced Full Rate (EFR) speech transcoding".
- [35] ETS 300 727 (GSM 06.61): "Digital cellular telecommunications system; Substitution and muting of lost frames for Enhanced Full Rate (EFR) speech traffic channels".
- [36] ETS 300 728 (GSM 06.62): "Digital cellular telecommunications system; Comfort noise aspects for Enhanced Full Rate (EFR) speech traffic channels".
- [37] ETS 300 729 (GSM 06.81): "Digital cellular telecommunications system; Discontinuous Transmission (DTX) for Enhanced Full Rate (EFR) speech traffic channels".
- [38] ETS 300 730 (GSM 06.82): "Digital cellular telecommunications system; Voice Activity Detection (VAD) for Enhanced Full Rate (EFR) speech traffic channels".
- [39] ETS 300 609-2 (GSM 11.23): "Digital cellular telecommunications system (Phase 2); Base Station System (BSS) equipment specification; Part 1: Signalling aspects".

3 Definitions and abbreviations

3.1 Definitions

Error-free radio conditions A condition for a test signal applied to the antenna connector, defined in subclause 4.1.1.1

Perfect radio conditions A condition for a test signal applied to the antenna connector, defined in subclause 4.1.1.1

3.2 Abbreviations

For the purposes of this ETS, the following abbreviations apply in addition to those given in ETR 100 (GSM 01.04) [1]:

AGCH	Access Grant CHannel
BCCH	Broadcast Control CHannel
BSS	Base Station System
BTS	Base Transceiver Station
CCU	Channel Coder Unit
DTX	Discontinuous Transmission
FACCH	Fast Associated Control CHannel
FS	Full rate Speech

HS	Half rate Speech
MSC	Mobile Switching Centre
OMC	Operations and Maintenance Centre
PCH	Paging CHannel
PCM	Pulse Code Modulation
RA	Rate Adaption
RACH	Random Access CHannel
TCH	Traffic CHannel
SACCH	Slow Associated Control CHannel
SDCCH	Standalone Dedicated Control CHannel
SCH	Synchronization Channel

4 Transcoding and rate adaption

The Transcoding and Rate Adaption Unit (TRAU) is a GSM entity which converts between the 64 kbit/s per channel bit rate at the MSC and a net rate of 13 kbit/s for the radio interface in the case of Full Rate (FR) speech. For terrestrial links the 13 kbit/s data is transmitted over 16 kbit/s after the addition of synchronisation and control information. On the radio interface the 13 kbit/s is padded to 22.8 kbit/s after channel coding. In the case of data the net bit rates used as the bearer can be either 12 kbit/s, 6 kbit/s or 3,6 kbit/s. Again channel coding results in a radio interface data rate of 22.8 kbit/s. While the transcoder is considered functionally part of the BSS it can be located at either the MSC location, BSC location or BTS location. This aspect is illustrated in figure 11.24-1. The 16 kbit/s terrestrial link to the remote transcoder may be (4 to 1) multiplexed onto a single 64 bit/s link as shown in BSS types 2,4 and 6.

In situations where the TRAU is located remote from the radio interface (i.e. BSS type 2, 4-7) speech or data is transferred between the TRAU and channel codec unit (CCU) in frames of fixed length of 320 bits (20ms). These "TRAU frames" also carry control signals that signal frame type and timing information. For example in-call modifications from speech to data will be signalled from the CCU to the TRAU within the frame structure. In the case of timing control the CCU checks the synchronisation of the downlink radio link and signals advance/retard information to the TRAU over the uplink TRAU frames. Corrections are then made to the downlink phasing of the TRAUs. For more information see GSM 08.60 [17].

Testing for the transcoding function will be divided into three categories:

- speech transcoding/DTX which is independent of BSS type;
- data rate adaption;

and

- In-band control which relates to types 2,4-7.

4.1 Transcoder test points

To facilitate the standardization of the testing the following interfaces are required:

4.1.1 External interfaces

The mandatory external interfaces of the BSS (according to figure 11.24-1) are listed below:

1. The antenna connector.
2. The A-interface to the MSC.

An additional optional external interface may be required:

3. The separate OMC-interface.

4.1.1.1 Test signals applied to the antenna connector

The purpose of the tests in this specification are to test the transcoding function of the BSS. Where tests are performed using the antenna connector as an external interface, the characteristics of the RF test signal

should be chosen so as to minimise the contribution of the BTS (especially its RF parts) to the measurement results.

NOTE: The BTS can contribute to the measurement result is due to the introduction of bit errors. This is most likely to occur if the level of the input signal is not large enough compared to the noise floor of the receiver, but can also occur if the input signal overloads the receiver.

The manufacturer may specify the RF characteristics of the test signal for these tests, which meet these requirements.

If the manufacturer does not specify the characteristics of the test signal, the signal and general test method defined in GSM 11.21 [19] for static reference sensitivity may be used, except that the level of the signal should be increased by at least 20dB.

Perfect radio conditions: Using a test signal as defined above, applied continuously to the antenna connector.

Error-free radio conditions: Using a test signal as defined above, applied for certain parts of the GSM radio interface frame structure, as defined in each test.

Alternatively, an internal interface point within the BTS may be used, with a test signal comprising the bit sequence which would result at the internal interface point for an error free test signal applied to the antenna connector.

4.1.2 Internal test points and interfaces

In addition to the external interfaces in clause 4.1.1 the following internal logical interfaces shall as a minimum be accessible in the equipment in order to carry out the measurements in this specification:

1. Input and output bit access to 104 kbit/s level, 13 bit linear PCM for full rate speech channels (TCH/FS) in both directions of transmission and reset control of the speech encoder and decoder.
2. Output bit access after channel decoding including frame erasure information (FEI or BFI) for all channel types.
3. Input bit access before channel encoding for all channel types.
4. The optional internal TRAU interface (referred to as Abis in GSM 08.60 [17]), if used.

Where an internal access is required, the implementation of this is up to the manufacturer. However, in order to physically interface with the BSSTE, the implementation is restricted to the following options:

- a. Direct physical access to the logical interface.
- b. Physical access via a dedicated external interface adapter.
- c. Physical access to bits (insertion and monitoring) before channel encoding/after channel decoding via a loop-back over the radio path as defined in GSM 11.10-1 [18] for the Mobile Station.
- d. Physical access to bits (insertion and monitoring) before channel encoding/after channel decoding from the A-interface using the A-interface rate adaptation functions.
- e. Physical access to bits (insertion and monitoring) before channel encoding/after channel decoding from the Abis-interface using the 16 kbit/s Abis-interface rate adaptation and speech handling functions, if any.
- f. Physical access to 13 bit/8 kHz PCM samples via a special combination of 2 x A- or Abis-interface 64 kbit/s channels.

A dedicated external adapter shall, if used, be supplied by the BSS manufacturer.

The internal test points or interfaces are illustrated in figure 11.24-2 and figure 11.24-3 for the various Base Station System types described in figure 11.24-1.

The detailed specifications of the interface points are:

- Interface point x:

TCH/FS: Input and output 104 kbit/s = 13 bit linear PCM at 8 kHz sampling rate
Reset control of the full rate speech encoder
TCH/HS: Input and output 104 kbit/s = 13 bit linear PCM at 8 kHz sampling rate
Reset control of the half rate speech encoder

No other channels are applicable.

- Interface point x':

TCH/FS: Input and output 104 kbit/s = 13 bit linear PCM at 8 kHz sampling rate
Reset control of the full rate speech decoder (or at interface point y')
TCH/HS: Input and output 104 kbit/s = 13 bit linear PCM at 8 kHz sampling rate
Reset control of the half rate speech decoder

No other channels are applicable.

- Interface point y:

Speech:

TCH/FS: Input/output 13 kbit/s = 260 bits every 20 ms
TCH/HS: Input/output 5.6 kbit/s = 112 bits every 20 ms

NOTE 1: For BSS types 4-7 input/output control can be handled via the Abis-interface.

Data:

TCH/F9,6: Input 12 kbit/s = 60 bits every 5 ms
TCH/F4,8: Input 6 kbit/s = 60 bits every 10 ms
TCH/F2,4: Input 3,6 kbit/s = 72 bits every 10 ms
TCH/H4,8: Input 6 kbit/s = 60 bits every 20 ms
TCH/H2,4: Input 3,6 kbit/s = 72 bits every 20 ms

Signalling:

FACCH/F: Input 184 bits (23 octets) every 20 ms
FACCH/H: Input 184 bits (23 octets) every 40 ms
SACCH/TF: Input 184 bits (23 octets) every 480 ms
SACCH/TH: Input 184 bits (23 octets) every 480 ms
SACCH/C8: Input 184 bits (23 octets) every 470.77 ms
SACCH/C4: Input 184 bits (23 octets) every 470.77 ms
SDCCH/8: Input 184 bits (23 octets) every 235.38 ms
SDCCH/4: Input 184 bits (23 octets) every 235.38 ms
BCCH: Input 184 bits (23 octets) every 235.38 ms
PCH: Input 184 bits (23 octets) every 235.38 ms
AGCH: Input 184 bits (23 octets) every 235.38 ms
RACH: Not applicable
SCH: Input 5 x 25 = 125 bits every 235.38 ms

- Interface point y':

Speech:

TCH/FS:	Input/Output 13 kbit/s = 260 bits every 20 ms Reset control of the full-rate speech decoder (or at interface point x')
TCH/HS:	Input/Output 5.6 kbit/s = 112 bits every 20 ms

NOTE 2: For BSS types 4-7 input/output and reset control can be handled via the Abis-interface.

All outputs of speech channels shall include the Bad Frame Indication (BFI). All bits shall be available, i.e. also bits in erased frames. No extrapolation shall be done.

Data:

TCH/F9,6:	Output 12 kbit/s = 60 bits every 5 ms
TCH/F4,8:	Output 6 kbit/s = 60 bits every 10 ms
TCH/F2,4:	Output 3,6 kbit/s = 72 bits every 10 ms
TCH/H4,8:	Output 6 kbit/s = 60 bits every 20 ms
TCH/H2,4:	Output 3,6 kbit/s = 72 bits every 20 ms

Signalling:

FACCH/F:	Output 184 bits (23 octets) every 20 ms
FACCH/H:	Output 184 bits (23 octets) every 40 ms
SACCH/TF:	Output 184 bits (23 octets) every 480 ms
SACCH/TH:	Output 184 bits (23 octets) every 480 ms
SACCH/C8:	Output 184 bits (23 octets) every 470.77 ms
SACCH/C4:	Output 184 bits (23 octets) every 470.77 ms
SDCCH/8:	Output 184 bits (23 octets) every 235.38 ms
SDCCH/4:	Output 184 bits (23 octets) every 235.38 ms
BCCH:	Not applicable
PCH:	Not applicable
AGCH:	Not applicable
RACH:	Output 8 bits every 4.62 ms
SCH:	Not applicable

All outputs of control channels shall include the Frame Erasure Indication (FEI). All bits shall be available, i.e. also bits in erased frames.

Position Z:	The 64 kbit/s level at the MSC interface ie. the A interface.
Position T:	The TRAU or Abis-interface (Usually at 16 kbit/s submultiplexed into a 64 kbit/s channel). This is the link between the TRAU and the CCU in the BSS or BTS.

BSS type 1
 (BSS to TRAU
 interface
 internal)

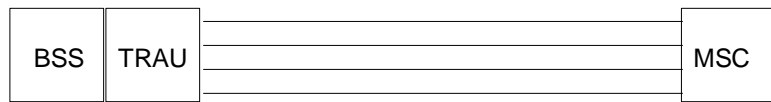

BSS type 2
 (BSS to TRAU
 interface
 external)



BSS type 3
 (BTS to TRAU
 interface
 internal)

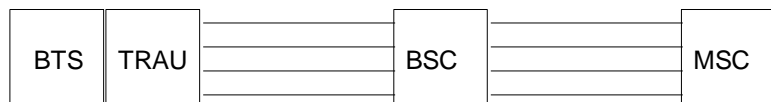

BSS type 4
 (BTS to TRAU
 interface
 external)

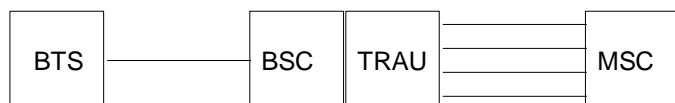

BSS type 5
 (BTS to TRAU
 interface
 external)

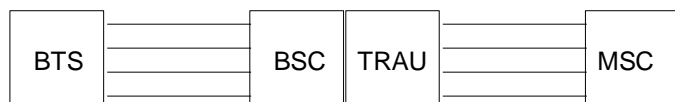

BSS type 6
 (BTS to TRAU
 interface
 external)



BSS type 7
 (BTS to TRAU
 interface
 external)

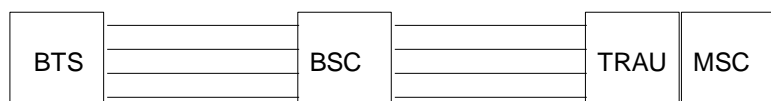

Figure 11.24-1: BSS types

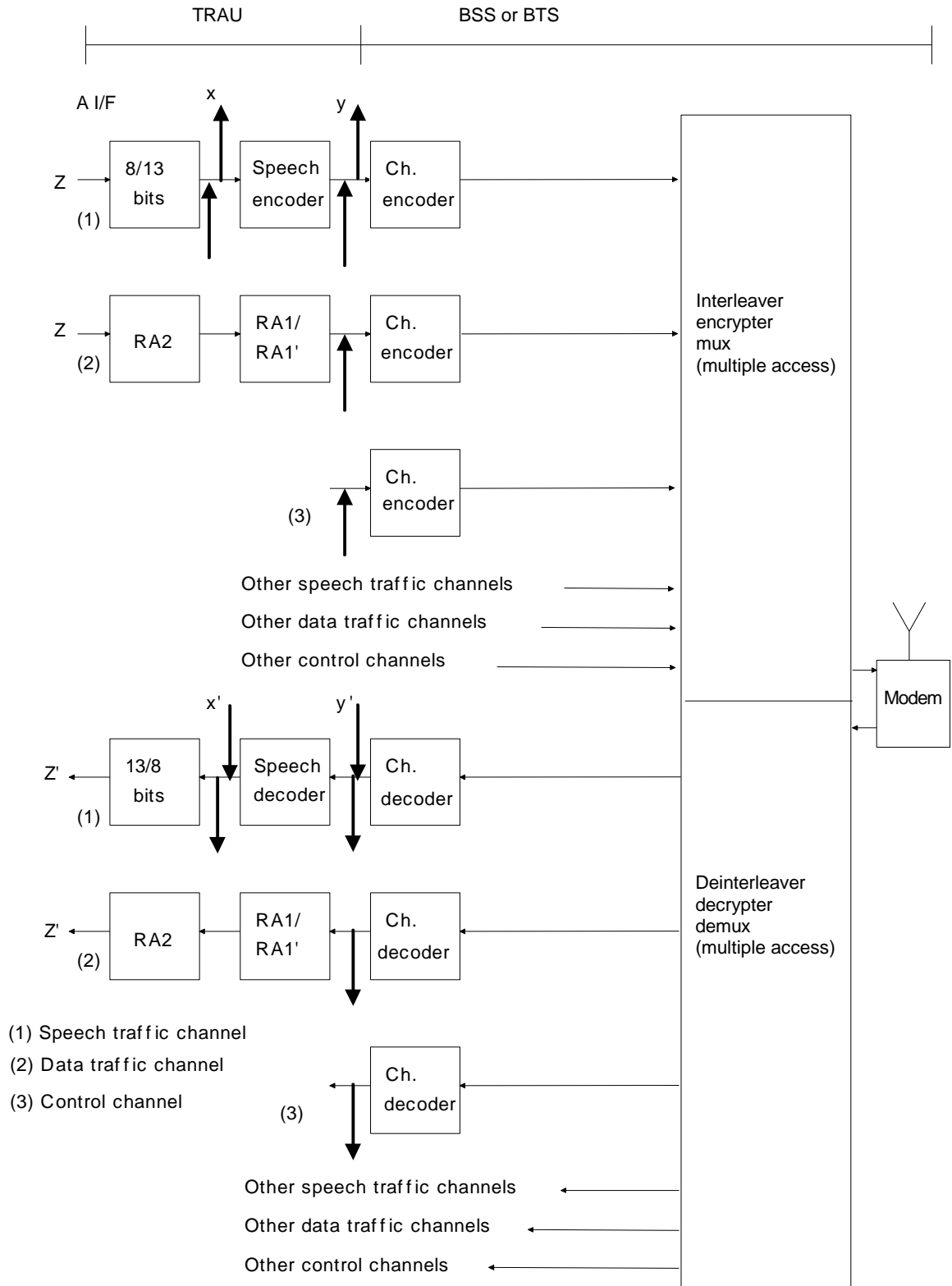

Figure 11.24-2: Test points or interfaces (BSS type 1 & 3)

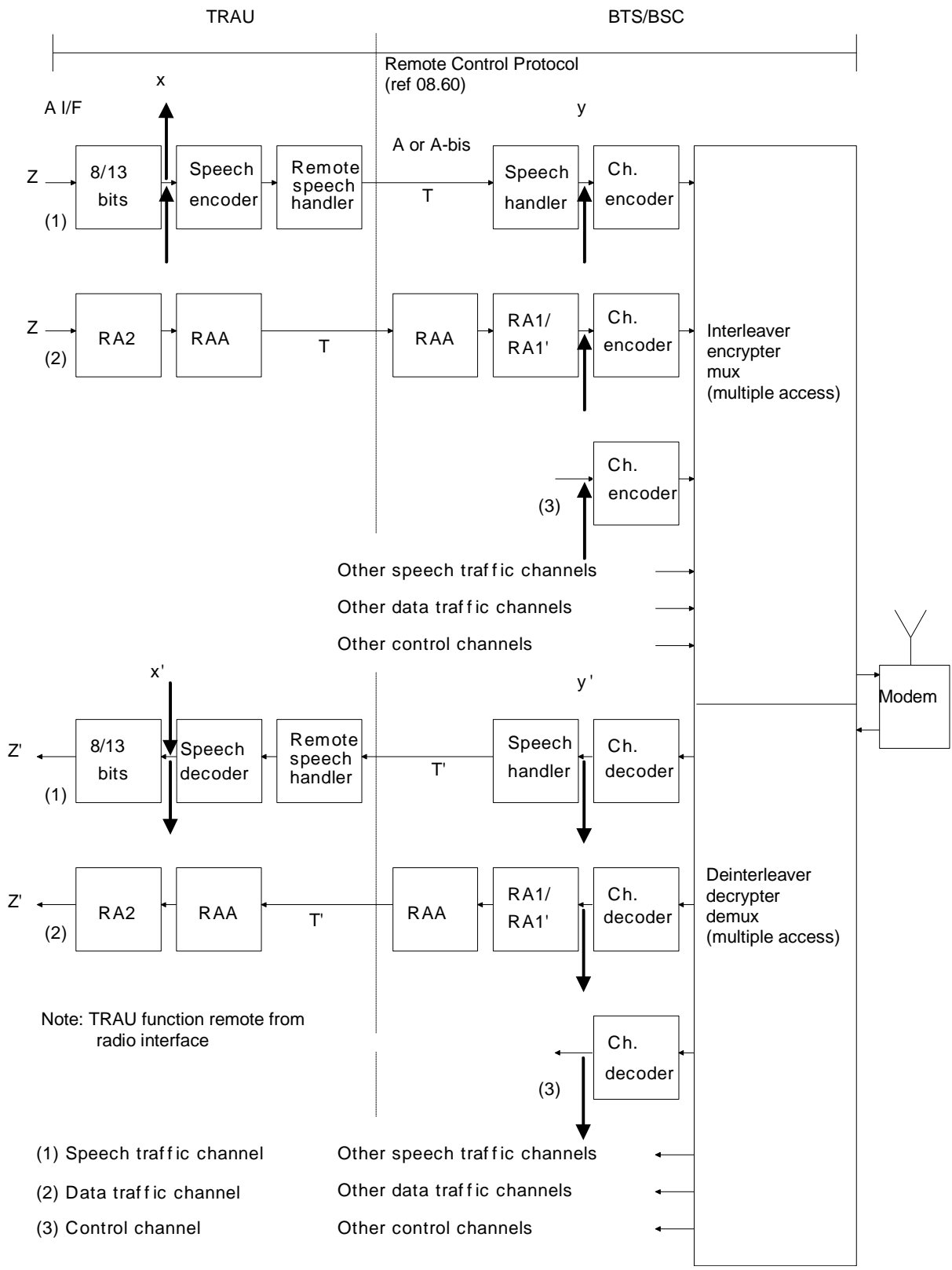

Figure 11.24-3: Test points or interfaces (BSS types 2, 4-7)

5 Test descriptions for speech related transcoding function

5.1 Test descriptions for full rate speech related transcoding functions

The Full Rate (FR) speech transcoding process consists of two fundamental steps. In the uplink, the first step transforms the 13 kbit/s bitstream into 104 kbit/s (13 bit linear PCM at 8 kHz). The second step transforms this 13 bit linear PCM into 8 bit A law PCM. In the downlink, the order is reversed. This is exactly followed in BSS types 1 and 3. For other BSS types, there is an intermediate step in which the 13 kbit/s data is mapped into a 16 kbit/s bitstream containing TRAU frames. TRAU frames are used to transport coded speech and data between the TRAU and CCU. In addition, specific speech functions are needed to support Discontinuous Transmission (DTX).

The test sequences for full rate speech transcoding are defined in GSM 06.10 [8] clause 5 and GSM 06.32 [12] clause 4 and can be obtained from ETSI Secretariat.

For further information see GSM 06.01 [7], GSM 06.10 [8], GSM 06.11 [9], GSM 06.12 [10], GSM 06.31 [11], GSM 06.32 [12] and GSM 08.60 [17].

5.1.1 Uplink tests

5.1.1.1 Uplink speech transcoding - 13 kbit/s to 104 kbit/s conversion

Test purpose

To verify the bit exact conversion of the net 13 kbit/s radio path bit stream to 104 kbit/s (13 bit linear PCM at 8 kHz) by the transcoding function operating on speech.

This test is applicable to BSS types 1 and 3.

Test case

Method of test

At 13 kbit/s level in the BSS, after channel decoding, a test sequence shall be input synchronized to the channel/speech decoders interface frame structure. Alternatively, the test sequence may be input via the air interface before channel encoding at 13 kbit/s level in the BSSTE. In the latter case the Layer 1 functions of the BSS must already be verified and the test must be performed under perfect radio conditions.

The sequences to be input in this test are contained in the files SEQ01.COD, SEQ03.COD, SEQ04.COD and SEQ05.COD. The files contain 16 bit words for all speech encoded parameters and are justified as described in GSM 06.10 [8] table 5.1. 76 words must be input in a period of 20 ms and the speech decoder must be reset before the start of the test (i.e. exactly before the start of the test sequences).

At 104 kbit/s level in the BSS, the output bit stream shall be recorded.

The transcoder may be put into test mode in order to accept the new input interface conditions (speech decoder reset), to generate output data at the test rate (104 kbit/s) and in order to disable the uplink DTX functions, which are not part of this test.

NOTE: The test sequences are stored on the diskettes as 16 bit words (2 bytes) where the least significant byte occurs first and the most significant byte occurs last (e.g. stored 10 0A hex is to be understood as 0A 10 hex).

Test Requirements

The output test point for all BSS types is test point x' shown in figure 11.24-2.

The output bit stream from the speech transcoder shall be continuous and bit by bit exactly the same as the predefined output sequences (SEQ01.OUT, SEQ03.OUT, SEQ04.OUT, SEQ05.OUT).

Conformance requirement

The transcoding algorithm requires that the 13 kbit/s compressed speech be first converted into a 104 kbit/s linear PCM bit stream. For correct interworking between the MS and BSS the conversion process is precisely defined.

Requirement reference

GSM 06.01 [7] clause 2
GSM 06.10 [8] clause 5.2.2

5.1.1.2 Uplink speech transcoding - 13 kbit/s to 16 kbit/s conversion

Test purpose

To verify the bit exact conversion of the net 13 kbit/s radio path bit stream to TRAU frames at 16kbit/s by the transcoding function operating on speech.

This test is applicable to BSS types 2, 4-7.

Test case

Method of test

At 13 kbit/s level in the BSS after channel decoding a test sequence shall be input synchronized to the channel/speech decoders interface frame structure. Alternatively, the test sequence may be input via the air interface before channel encoding at 13 kbit/s level in the BSSTE. In the latter case the Layer 1 functions of the BSS must already be verified and the test must be performed under perfect radio conditions.

The test sequences for speech transcoding are defined in GSM 06.10 [8] clause 5 and can be obtained from ETSI Secretariat (see GSM 06.10 [8]).

The input shall be maintained for a duration of at least a duration of 40 ms or 2 speech frames.

At the Abis-interface (position T) the output bit stream shall be recorded.

The uplink DTX functions may be disabled as it is not part of this test.

Test requirements

The data in the TRAU frames shall be bit exact with the input data.

Conformance requirement

The 13 kbit/s raw data taken from the radio interface is mapped onto TRAU frames which are used to send the data to the transcoder located at the remote end.

Requirement reference

GSM 08.60 [17] clause 3.1

5.1.1.3 Uplink speech transcoding - 16 kbit/s to 104 kbit/s conversion

Test purpose

To verify the bit exact conversion of the encoded data in the TRAU frames to 13 bit/8 kHz linear PCM by the transcoding function operating on speech.

This test is applicable to BSS types 2, 4-7.

Test case**Method of test**

Conditions are as in clause 5.1.1.1 except that the test sequence shall be inserted at the 16 kbps TRAU interface with the traffic bits being the same as the bits used in the 13 kbps interface point as used for BSS types 1 and 3 in clause 5.1.1.1.

Test requirements

As in clause 5.1.1.1.

Conformance requirements

The 13 kbit/s data is extracted from the TRAU frames by the transcoder and converted to 104 kbit/s linear PCM.

Requirement reference

GSM 06.10 [8] Speech decoder parts

5.1.1.4 Uplink speech transcoding - 104 kbit/s to 64 kbit/s conversion**Test purpose**

To verify that the transcoding function correctly transforms 13 bit linear PCM to 8 bit A-law PCM in a bit exact manner.

This test is applicable to BSS types 1-7.

Test case**Method of test**

A test sequence containing all possible 13 bit codewords shall be input at 104 kbit/s level in the BSS. Test point x' shall be used for inserting the test signal. At 64 kbit/s level in the BSS (position Z) the output shall be recorded.

The transcoder may be put into test mode in order to enable the input test interface (104 kbit/s).

Test Requirements

The correspondence between codewords at input and output shall be according to recommendation CCITT G.721 clause 4.2.1 subblock COMPRESS. The parameter LAW=1 shall be used.

Conformance requirement

The transcoding algorithm requires that the 104 kbit/s linearly encoded speech be converted to a 64 kbit/s A law PCM data stream. For correct interworking between the MS and BSS, the conversion process must be totally compatible.

Requirement reference

GSM 06.10 [8]

5.1.1.5 Uplink Speech Decoder - 13 kbit/s to 104 kbit/s conversion with DTX

Test purpose

To verify the correct operation of the SID-frame detector, comfort noise generator, speech extrapolation and muting functions when the TRAU is at the radio interface.

This test is applicable to BSS types 1 and 3.

Test case

Method of test

At 13 kbit/s level in the BSSTE (before channel encoding) coded "speech" traffic frames containing a special test signal defined below shall be input and transmitted over error-free radio conditions. All traffic frames shall be identical with the exception of some frames which are SID-frames as defined in GSM 06.31 [11].

At 104 kbit/s level in the BSS (13 bit linear PCM at 8 kHz), the signal shall be output and the signal energy of the PCM signal shall be evaluated (as a mean square average) and recorded for each block of 20 ms synchronized to the 20 ms speech frame structure.

The TDMA frames of the TCH/FS transmitted on the radio path shall be ramped "on" or "off" on a traffic frame by traffic frame basis, taking into account the block-diagonal interleaving scheme defined in GSM 05.03 [5]. The first traffic frame in step 1 shall occur one frame after the window of the SACCH multiframe (TDMA frame 60 modulo 104) allocated for the SID-frame (see GSM 05.02 [4] and 05.08 [6]). The SACCH shall be transmitted.

NOTE: 8 timeslots in 8 consecutive TCH/FS TDMA-frames shall be seen as one traffic frame and the next traffic frame starts in the middle of the previous one (i.e. after 4 TDMA-frames of the previous one) due to the block diagonal interleaving scheme defined in GSM 05.03 [5].

The special test frame is an encoded "speech" traffic frame of 260 bits obtained from white Gaussian noise band limited to 300 - 3 400 Hz. When repeated, the special test frame results in a humming sound with a fairly constant level when decoded, and is defined in table 11.24-1:

Table 11.24-1: Special test traffic frame for receiver DTX tests

Encoded parameter:	Value:
LARc(1)	38
LARc(2)	42
LARc(3)	24
LARc(4)	20
LARc(5)	10
LARc(6)	9
LARc(7)	5
LARc(8)	3

	Subblock no:			
	0	1	2	3
Grid position (Mc)	1	3	2	0
Block amplitude (xmaxc)	40	40	40	40
LTP gain (Bc)	0	0	0	0
LTP lag (Nc)	40	120	40	120
RPE pulses (xmc)				
- pulse no 1	4	6	6	6
- pulse no 2	4	5	4	3
- pulse no 3	2	1	3	4
- pulse no 4	6	2	1	3
- pulse no 5	3	6	4	1
- pulse no 6	5	1	6	3
- pulse no 7	5	2	5	5
- pulse no 8	5	6	2	1
- pulse no 9	1	3	4	4
- pulse no 10	3	2	4	3
- pulse no 11	5	5	4	5
- pulse no 12	6	1	2	2
- pulse no 13	1	3	4	3

The signal energy of the special test frame is controlled with the block amplitude parameter (xmaxc). Reducing xmaxc from 40 to 32 reduces the signal energy by 6 dB, and reducing xmaxc from 40 to 24 reduces the signal energy by 12 dB.

The sequence of frames shall be as follows:

1. 23 test frames "on".
2. 20 frames "off".
3. 20 test frames "on".
4. 1 SID-frame followed by 6 frames "off", another identical SID-frame and 23 frames "off". Except for the SID codeword, the SID-frames shall be identical to the special test frame.
5. 1 different SID-frame, however with 2 to 15 errors inserted in the SID codeword, followed by 23 frames "off".
6. 20 test frames "on", but with the block amplitude parameter xmaxc=24.
7. 1 SID-frame followed by 50 frames "off". Except for the SID codeword, the SID-frames shall be identical to the special test frame.

8. The whole test shall be repeated, but the frames "off" shall be replaced by frames "on" with the FACCH flag set.

Test Requirements

- 1) In the case of step 1, the signal energy shall be fairly constant within +/- 3 dB.
- 2) In the case of step 2, the signal energy shall decrease by greater than 40 dB within 17 frames.
- 3) In the case of step 3, the same requirements as in step 1 apply.
- 4) In the case of step 4, comfort noise shall be generated. The same requirements as in step 1 apply (in terms of level).
- 5) In the case of step 5, the same requirements as in step 4 apply.
- 6) In the case of step 6, the same requirements as in step 1 apply. However, the signal energy shall be 12 dB lower.
- 7) In the case of step 7, the signal energy shall be fairly constant within +/- 3 dB for 28 frames. Then the signal energy shall decrease by greater than 40 dB within 16 frames.
- 8) In the case of step 8, the same requirements as in all previous steps apply.

Conformance requirement

- 1) The output level of the decoder be constant for an input signal consisting of identical speech frames.
- 2) When, after the first lost speech frame has been substituted, subsequent speech frames are lost, a muting technique shall be used that will gradually decrease the output level, resulting in silencing of the output after a maximum of 320 ms.
- 3) As in 1).
- 4) A valid SID-frame followed by a sequence of lost speech frames shall result in comfort noise generation with constant block amplitude parameters.
- 5) An invalid SID-frame followed by a sequence of lost speech frames shall result in comfort noise generation, using the set of parameters from the last valid SID-frame.
- 6) The energy of the output signal is controlled by the block amplitude parameter x_{maxc} .
- 7) The first SID-frame that is expected and not received shall be substituted by the last valid SID-frame and the procedure for valid SID-frames shall be applied. For the second lost SID-frame, a muting technique shall be used that will gradually decrease the output level, resulting in silencing the output after a maximum of 320 ms.
- 8) Speech frames with the FACCH flag set provoke a Bad Frame Indication (BFI=1) and are hence regarded as lost speech frames.

Requirement reference

- 1) GSM 06.10 [8]
- 2) GSM 06.01 [7] clause 6
GSM 06.11 [9] clauses 2.1, 2.2, 3
- 3) As in 1)
- 4) GSM 06.01 [7] clauses 3, 5
GSM 06.12 [10] clauses 3, 3.1
GSM 06.31 [11] clauses 1.2.2, 3.1, 3.1.1, 3.1.2

- 5) GSM 06.01 [7] clauses 3, 5
GSM 06.12 [10] clauses 3, 3.1
GSM 06.31 [11] clauses 1.2.2, 3.1, 3.1.1, 3.1.2
- 6) GSM 06.10 [8] clauses 3.1.20, 3.1.21, 3.2.1
- 7) GSM 05.08 [6] clause 8.3
GSM 06.01 [7] clause 6
GSM 06.11 [9] clauses 2.3, 2.4
GSM 06.31 [11] clauses 1.2.2, 3.1.1, 3.1.2
- 8) GSM 06.31 [11] clauses 1.2.2, 3.1.1

5.1.1.6 Uplink Speech Decoder - 13 kbit/s to 16 kbit/s conversion with DTX

Test purpose

To verify that the TRAU frames generated by the Channel Coder Unit respond correctly to the reception of SID frames on the radio interface.

This test is applicable to BSS types 2, 4-7.

Test case

Method of test

At 13 kbit/s level in the BSSTE (before channel encoding), the same sequence as defined in clause 5.1.1.5 shall be input in the uplink direction and transmitted over error-free radio conditions. The first traffic frame in step 1 shall occur one frame after the window of the SACCH multiframe (TDMA frame 60 modulo 104) allocated for the SID-frame (see GSM 05.02 [4] and 05.08 [6]). The SACCH shall be transmitted.

At Abis-interface (position T) the output bit stream shall be recorded.

Test Requirements

- 1) For frames no. 1 to 23, the recorded values for BFI and SID in the TRAU frames shall be: BFI = 0, SID = 0.
- 2) For frames no. 24 to 43, the recorded values for BFI and SID in the TRAU frames shall be: BFI = 1, SID = 0.
- 3) For frames no. 44 to 63, the recorded values for BFI and SID in the TRAU frames shall be: BFI = 0, SID = 0.
- 4) For frame no. 64, the recorded values for BFI and SID in the TRAU frames shall be: BFI = 0, SID = 2. For frames no. 65 to 70, the recorded values for BFI and SID in the TRAU frames shall be: BFI = 1, SID = 0. For frame no. 71, the recorded values for BFI and SID in the TRAU frames shall be: BFI = 0, SID = 2. For frames no. 72 to 94, the recorded values for BFI and SID in the TRAU frames shall be: BFI = 1, SID = 0.
- 5) For frame no. 95, the recorded values for BFI and SID in the TRAU frames shall be: BFI = 0, SID = 1. For frames no. 96 to 118, the recorded values for BFI and SID in the TRAU frames shall be: BFI = 1, SID = 0.
- 6) For frames no. 119 to 138, the recorded values for BFI and SID in the TRAU frames shall be: BFI = 0, SID = 0.
- 7) For frame no. 139, the recorded values for BFI and SID in the TRAU frames shall be: BFI = 0, SID = 2. For frames no. 140 to 189, the recorded values for BFI and SID in the TRAU frames shall be: BFI = 1, SID = 0.
- 8) The recorded value for TAF in the TRAU frames shall be TAF = 1 for frame no. 24, 48, 72, 96, 120, 144 and 168. For all the other frames TAF = 0.

- 9) When the test is repeated with frames "off" replaced by frames "on" with the FACCH flag set, the same requirements as in all previous steps apply.

Conformance requirement

The overall operation of the full rate DTX receiver functions consists of, apart from the channel decoder, a SID frame detection function which is part of the Speech Handler in the BTS. The side information to be transmitted uplink from the BTS with the speech frame over the TRAU frames is a binary Bad Frame Indication (BFI) flag, a binary Time Alignment Flag (TAF) and a ternary Silence Descriptor (SID) flag.

The channel decoder including the BFI is tested in GSM 11.21 [19].

NOTE: When special test frames are input on the radio interface, TRAU frames containing (BFI,SID) = (0,0) occur on the TRAU interface. When SID frames are input on the radio interface, TRAU frames containing (BFI,SID) = (0,2) occur on the TRAU interface under nonlimiting radio transmission conditions. When SID frames are input on the radio interface under limiting radio transmission conditions, TRAU frames containing BFIs of 0 and 1 and SIDs of 0,1 or 2 shall occur on the TRAU interface. Under all conditions, when the input test frame or SID frame on the radio interface comes in the middle of a SACCH multiframe according to GSM 05.08 [6], the TAF flag shall be set to 1. Other wise TAF = 0.

Requirement reference

GSM 06.31 [11]

5.1.1.7 Uplink Speech Decoder - 16 kbit/s to 104 kbit/s conversion with DTX

Test purpose

When the TRAU is remote from the radio interface it should correctly respond to the DTX modulated 16 kbit/s signal. The output is tested at the 104 kbit/s level.

This test is applicable to BSS types 2, 4-7.

Test case

Method of test

A call shall be set up on a full rate speech TCH, and then TRAU frames containing traffic bits being the special test frame defined in clause 5.1.1.5 shall be input on the Abis-interface (position T). All TRAU frames shall contain identical traffic bits. The continuous sequence of TRAU frames shall contain the following combinations of flags:

1. 50 frames with (BFI,SID)=(0,0) and TAF=0 (good speech frames).
2. 20 frames with (BFI,SID)=(1,0) and TAF=0 (unusable frames).
3. 50 frames with (BFI,SID)=(0,0) and TAF=0 (good speech frames).
4. 1 frame with (BFI,SID)=(0,2) and TAF=0 (valid SID frame) followed by 30 frames with (BFI,SID)=(1,0) and TAF=0 (unusable frames).
5. 1 frame with (BFI,SID)=(0,1) and TAF=0 (invalid SID frame) followed by 50 frames with (BFI,SID)=(1,0) and TAF=0 (unusable frames).
6. 1 frame with (BFI,SID)=(1,2) and TAF=0 (invalid SID frame) followed by 50 frames with (BFI,SID)=(1,0) and TAF=0 (unusable frames).

7. 1 frame with (BFI,SID)=(1,1) and TAF=0 (invalid SID frame) followed by 50 frames with (BFI,SID)=(1,0) and TAF=0 (unusable frames).
8. 50 frames with (BFI,SID)=(0,0) and TAF=0 (good speech frames), but with the level parameter $x_{maxc}=24$.
9. 1 frame with (BFI,SID)=(0,2) and TAF=0 (valid SID frame) followed by 30 frames with (BFI,SID)=(1,0) and TAF=0 (unusable frames).
10. 1 frame with (BFI,SID)=(1,0) and TAF=1 (unusable frame , but SID expected) followed by 20 frames with (BFI,SID)=(1,0) and TAF=0 (unusable frames).
11. 1 frame with (BFI,SID)=(1,0) and TAF=1 (unusable frame , but SID expected) followed by 20 frames with (BFI,SID)=(1,0) and TAF=0 (unusable frames).
12. Step 1 shall be repeated, and then 20 frames with (BFI,SID)= (0,0) and TAF=0 (good speech frames), but with errors in the control bits.
13. Step 1 shall be repeated, and then 20 frames with (BFI,SID)= (0,0) and TAF=0 (good speech frames), but each with at least one framing bit error.

At 104 kbit/s level in the BSC (13 bit linear PCM at 8 kHz), the signal shall be output and the signal energy of the PCM signal shall be evaluated (as a mean square average, see clause 5.1.1.5) and recorded for each block of 20 ms synchronized to the 20 ms speech frame structure.

The transcoder may be put into test mode in order to enable the test output interface (104 kbit/s).

Test Requirements

- 1) In the case of step 1, the signal energy shall be fairly constant within +/- 3 dB.
- 2) In the case of step 2, the signal energy shall decrease by greater than 40 dB within 17 frames.
- 3) In the case of step 4, comfort noise shall be generated. The same requirements as in step 1 apply.
- 4) In the case of steps 5, 6 and 7 the same requirements as in step 4 apply.
- 5) In the case of step 8, the same requirements as in step 1 apply. However, the signal energy shall be 12 dB lower.
- 6) In the case of step 9, the same requirements as in step 4 apply. However, the signal energy shall be 12 dB lower.
- 7) In the case of step 10, the same requirements as in step 9 apply.
- 8) In the case of step 11, the same requirements as in step 2 apply.
- 9) In the case of step 12, the same requirements as in step 1 apply.
- 10) In the case of step 13, the signal energy shall decrease by greater than 40 dB within 320 ms + 60 ms = 380 ms. See also clause 7.3.3.6.3 (frame synchronization monitoring and recovery).

Conformance requirement

The overall operation of the full rate DTX receiver functions are described in GSM 06.31 [11], consisting of, apart from the speech decoder, a Comfort Noise (CN) generation function and an extrapolation and muting function for lost speech frames. These functions are parts of the remote Speech Handler in the BSC.

The side information to be received in the BSC with the speech frame over the TRAU interface is a binary Bad Frame Indication (BFI) flag, a binary Time Alignment Flag (TAF) and a ternary Silence Descriptor (SID) flag.

The speech decoder is tested in clauses 5.1.1.1 - 5.1.1.2.

Requirement reference

Details of the overall DTX operation for full rate speech are given in GSM 06.31 [11] , the speech extrapolation and muting functions are described in in GSM 06.11 [9] and the comfort noise aspects in GSM 06.12 [10].

5.1.2 Downlink tests

Both standard and DTX tests are provided. It is a national or operator specific matter whether or not to implement downlink DTX in a BSS.

5.1.2.1 Downlink speech transcoding - 64 kbit/s to 104 kbit/s conversion

Test purpose

To verify that the transcoding function correctly transforms 8 bit A-law PCM to 13 bit linear PCM. For further information see GSM 06.10 [8].

This test is applicable to BSS types 1-7.

Test case

Method of test

A test sequence containing all possible 8 bit codewords shall be input at 64 kbit/s level in the BSS. At 104 kbit/s level in the BSS the output shall be recorded.

The transcoder may be put into test mode in order to enable the output test interface (104 kbit/s).

Test Requirements

The correspondence between codewords at input and output shall be according to recommendation CCITT G.721 clause 4.2.1 subblock EXPAND. The parameter LAW=1 shall be used.

Conformance requirement

The relationship between A law and linear PCM given by the transcoder shall be compliant with CCITT G.721.

Requirement reference

GSM 06.10 [8] clause 5.1.2.1.

5.1.2.2 Downlink speech transcoding - 104 kbit/s to 13 kbit/s conversion

Test purpose

This transcoding transforms 13 bit linear PCM at 8 kHz to the 13 kbit/s net radio path bit stream.

This test is applicable to BSS types 1 and 3.

Test case

Method of test

At 104 kbit/s level in the BSS a test sequence shall be input synchronized to the speech encoder input interface frame structure. The test sequences for speech transcoding are defined in GSM 06.10 [8] clause 5 and can be obtained from ETSI Secretariat (see GSM 06.10 [8]).

The sequences to be input in this test are contained in the files SEQ01.INP, SEQ02.INP, SEQ03.INP and SEQ04.INP. The files contain 16 bit words for 13 bit linear PCM left justified. See also GSM 06.10 [8] table 5.1. The speech encoder must be reset before the start of the test (i.e. exactly before the start of the test sequences).

At 13 kbit/s level in the BSS the output bit stream shall be recorded. The output may be read directly via physical access in the BSS or via the air interface at 13 kbit/s level in the BSSTE. In the latter case the Layer 1 functions of the BSS must already be verified and the test must be performed under perfect radio conditions.

The transcoder may be put into test mode in order to enable the new input interface conditions (speech encoder reset and 104 kbit/s rate) and in order to disable the downlink DTX functions, which are not part of this test.

NOTE: The test sequences are stored on the diskettes as 16 bit words (2 bytes) where the least significant byte occurs first and the most significant byte occurs last (e.g. stored 10 0A hex is to be understood as 0A 10 hex).

Test Requirements

The bit stream output shall be bit by bit exactly the same as the sequence given in the files SEQxx.COD on the floppy disks. These files contain 16 bit words of all the 76 parameters in a speech frame justified as in GSM 06.10 [8] table 5.1. 76 codewords shall occur in a frame of 20 ms.

Conformance requirement

The output bit stream from the transcoder shall be bit by bit exactly the same as the predefined output sequences SEQ01.COD, SEQ02.COD, SEQ03.COD and SEQ04.COD.

Requirement reference

GSM 06.01 [7] clause 2
GSM 06.10 [8] clauses 5.2, 5.2.1

5.1.2.3 Downlink speech transcoding - 104 kbit/s to 16 kbit/s conversion

Test purpose

This transcoding transforms 13 bit linear PCM at 8 kHz to the 16 kbit/s level.

This test is applicable to BSS types 2, 4-7.

Test case

Method of test

This test shall be performed in the same way as in clause 5.1.2.2 except that the output test point is the 16 kbit/s level where the traffic bits in the TRAU frames shall be treated in the same way as the traffic bits at the 13 kbit/s level for the test results.

Test Requirements

As is clause 5.1.2.2 with the output data taken from the TRAU frame.

Conformance requirement

The output bit stream from the transcoder that is embedded in the TRAU frames shall be bit by bit exactly the same as the predefined output sequences SEQ01.COD, SEQ02.COD, SEQ03.COD and SEQ04.COD.

Requirement reference

GSM 06.01 [7] clause 2

GSM 06.10 [8] clause 5.2, 5.2.1

5.1.2.4 Downlink speech transcoding - 16 kbit/s to 13 kbit/s conversion

Test purpose

To verify the bit exact conversion of the data in the TRAU frames at 16kbit/s to the net 13 kbit/s bit stream prior to the channel coding by the speech handler.

This test is applicable to BSS types 2,4-7.

Test case

Method of test

At the Abis-interface (position T) a test sequence of data shall be fed to the BTS by means of TRAU frames at the 16 kbit/s level. The TRAU frames may have timing advance bits that command "no change".

The test sequence recommended to be used is SEQ01.COD as referred to in GSM 06.10 [8] clause 5 and can be obtained from the ETSI secretariat.

At the 13 kbit/s level the output data shall be monitored. Alternatively the output can be monitored via the air interface at the 13 kbit/s level in the BSSTE after channel decoding. In the latter case the layer 1 functions of the BTS must already have been verified and the test must be performed under perfect radio conditions.

The input and output shall be monitored for the duration of the sequence.

The downlink DTX functions may be disabled as it is not part of this test.

Test requirements

The output data shall be bit exact with the input data held within the TRAU frames.

Conformance requirement

In the downlink (at the BTS) the data bits in the TRAU frames should be extracted and used to produce a 13 kbit/s data stream for the channel encoder.

Requirement reference

GSM 08.60 [17] clause 3.1

5.1.2.5 Downlink transmitter DTX/VAD functions - 104 kbit/s to 13 kbit/s level conversion with DTX

Test purpose

To verify that

- 1) To verify that the combination of VAD and DTX operates correctly.
- 2) To verify that SID-frames are generated and positioned correctly after the start of a speech pause.

This test references the conversion from the 104 kbit/s level to the 13 kbit/s level on the radio interface.

This test is applicable to BSS types 1, 3.

Test case

Method of test

- a) The test sequence SPECT_A1.INP of PCM samples, which are grouped into frames of 20 ms synchronized to the TDMA and traffic frame structure on the air interface, is sent downlink on the 104 kbit/s level (13 bit linear PCM at 8 kHz).

The start of the test sequences is synchronized with the radio transmission on the air interface so that the first traffic frame on the air occurs just after the traffic frame allocated for the SID frame (TDMA frame 56 modulo 104, see GSM 05.02 [4] and GSM 05.08 [6]).

NOTE: 8 timeslots in 8 consecutive TCH/FS TDMA frames are seen as one traffic frame and the next traffic frame starts in the middle of the previous one (i.e. after 4 TDMA frames of the previous one) due to the block diagonal interleaving scheme defined in GSM 05.03 [5].

- b) The BSSTE detects whether or not there is any power transmitted over the radio path on a timeslot basis excluding SACCH frames. The speech frame by speech frame on/off transmission (on = 1) is recorded.
- c) The test is repeated for all test sequences *.INP described in GSM 06.32 [12] clause 4.

Test Requirements

The traffic frame on/off sequence recorded shall be bit-exact like the sequence of SP-flags stored as bit 15 of LAR(2) on the reference files *.COD defined in GSM 06.32 clause 4, with the following exceptions:

1. The occurrence of a SID-frame in its allowed window within the SACCH multiframe as defined in GSM 05.08 [6].
2. The occurrence of a SID-frame after 1 or more real speech frames consecutively transmitted on the air.

Conformance requirement

The DTX/VAD transmitter functions allow only those frames to be transmitted that are either marked with SP = 1 or that are properly positioned SID frames.

Requirement reference

GSM 05.08 [6] clause 8.3

GSM 06.01 [7] clauses 3, 4

GSM 06.31 [11] clauses 2.1, 2.1.1, 2.1.2

GSM 06.32 [12] clauses 1, 2, 2.1, 2.2.8

5.1.2.6 Downlink transmitter DTX/VAD functions - 104 kbit/s to 16 kbit/s conversion process

Test purpose

To verify that the TRAU frame's speech flag SP = 1 when it is a speech frame and SP=0 when it is not.

This test is applicable to BSS types 2, 4, 5, 6 and 7.

Test case

Method of test

- a) The test sequence SPECT_A1.INP of PCM samples, which are grouped into frames of 20 ms synchronized to the TDMA and traffic frame structure on the air interface, is sent downlink on the 104 kbit/s level (13 bit linear PCM at 8 kHz).

The start of the test sequences is synchronized with the radio transmission on the air interface so that the first traffic frame on the air occurs just after the traffic frame allocated for the SID frame (TDMA frame 56 modulo 104, see GSM 05.02 [4] and GSM 05.08 [6]).

NOTE: 8 timeslots in 8 consecutive TCH/FS TDMA frames are seen as one traffic frame and the next traffic frame starts in the middle of the previous one (i.e. after 4 TDMA frames of the previous one) due to the block diagonal interleaving scheme defined in GSM 05.03 [5].

- b) On the TRAU interface, the sequence of SP-flags is recorded.
- c) The test is repeated for all test sequences *.INP described in GSM 06.32 [12] clause 4. The transcoder may be put into test mode in order to activate the 104 kbit/s level input test interface.

Test Requirements

In step b), the recorded SP-flag sequence shall be bit-exact compared to the sequence of SP-flags stored as bit 15 of LAR(2) on the reference files *.COD.

Conformance requirement

If implemented, the overall operation of the full rate DTX transmitter functions are described in GSM 06.31 [11], consisting of, apart from the speech encoder, a Voice Activity Detector (VAD) and a TX DTX handler, in this case both being a part of the remote Speech Handler in the BSC.

The side information to be transmitted with the speech frame over the TRAU interface is a binary flag Speech (SP). SP=1 indicates that the TRAU frame is a speech frame and SP=0 indicate that the TRAU frame is a special SID-frame. This flag is used in the BTS for control of the radio transmission.

The speech encoder is tested in clauses 5.1.2.1 and 5.1.2.2.

Requirement reference

GSM 06.01 [7] clauses 3, 4
GSM 06.31 [11] clauses 2.1, 2.1.1, 2.1.2
GSM 06.32 [12] clauses 1, 2, 2.1, 2.2.8

5.1.2.7 Downlink transmitter DTX/VAD functions - 16 kbit/s to 13 kbit/s conversion

Test purpose

To verify that:

1. The frames on the radio interface are transmitted continuously when the speech flag SP=1.
2. The frames on the radio interface occur in the middle of the SACCH multiframe when SP=0 except for the first one after the SP=1 to 0 transition which is transmitted.

This test references the conversion from the 16 kbit/s level to the 13 kbit/s level on the radio interface.

This test is applicable to BSS types 2, 4, 5, 6 and 7.

Test case**Method of test**

A call shall be set up on a full rate speech TCH, and then TRAU frames with random traffic bits accompanied with SP=0 or 1 in a random order shall be input on the TRAU interface.

Test requirements

On the radio interface the following full rate "speech" traffic frames shall be transmitted on the air on the TCH/FS:

1. All frames with SP=1.
2. The first frame with SP=0 after one or more with SP=1.
3. Those marked with SP=0 and occurring in the middle of the SACCH multiframe as defined in GSM 05.08 [6].

No other frames with SP=0 shall be transmitted on the air.

NOTE: Due to the block diagonal interleaving scheme defined for the TCH/FS, every traffic frame is transmitted in 8 TDMA frames. Since every TDMA frame contains 2 different traffic frames, there is not a one to one mapping between traffic frames "on" and TDMA frames transmitted on the air.

Conformance requirement

If implemented, the overall operation of the full rate DTX transmitter functions are described in GSM 06.31 [11], consisting of, apart from the channel encoder, an SP flag handling and monitoring function which in this case is in the Speech Handler in the BTS.

The side information to be transmitted with the speech frame over the TRAU interface is a binary flag Speech (SP). SP=1 indicates that the TRAU frame is a speech frame and SP=0 indicate that the TRAU frame is a special SID-frame. This flag is used in the BTS for control of the radio transmission.

The channel encoder is tested in subclause 7.2 of GSM 11.21 [19].

Requirement reference

GSM 06.31 [11]

5.2 Test descriptions for half rate speech related transcoding functions

The two steps for the Half Rate (HR) speech transcoding process consists in the following. In the uplink the first step transforms the 5.6 kbit/s bitstream into 104 kbit/s (13 bit linear PCM at 8 kHz). The second step transforms this 13 bit linear PCM into 8 bit A law PCM. In the downlink the order is reversed. This is exactly followed in BSS types 1 and 3. For other BSS types there is an intermediate step in which the 5.6 kbits/s data is mapped into a 16 kbit/s or an 8 kbit/s bitstream containing TRAU frames.

The test sequences for half rate speech transcoding are defined in GSM 06.07 [24] and can be obtained from ETSI Secretariat. The tests for half rate are the same as the ones described for full rate.

For further information see GSM 06.02 [22], GSM 06.06 [23], GSM 06.07 [24], GSM 06.20 [25], GSM 06.21 [26], GSM 06.22 [27], GSM 06.41 [28], GSM 06.42 [29] and GSM 08.61 [30].

5.3 Test descriptions for enhanced full rate speech related transcoding functions

The two steps for the Enhanced Full Rate (EFR) speech transcoding process consists in the following. In the uplink the first step transforms the 12.2 kbit/s bitstream into 104 kbit/s (13 bit linear PCM at 8 kHz). The second step transforms this 13 bit linear PCM into 8 bit A law PCM. In the downlink the order is reversed.

This is exactly followed in BSS types 1 and 3. For other BSS types there is an intermediate step in which the 12.2 kbit/s data is mapped into a 16 kbit/s bitstream containing TRAU frames.

The test sequences for enhanced full rate speech transcoding are defined in GSM 06.54 [31] and can be obtained from ETSI Secretariat. The tests for half rate are the same as the ones described for full rate.

For further information see GSM 06.51 [32], GSM 06.53 [33], GSM 06.60 [34], GSM 06.61 [35], GSM 06.62 [36], GSM 06.81 [37], GSM 06.82 [38] and GSM 08.60 [17].

5.4 Alternative use of the 64 kbit/s A-Interface for full, half and enhanced full rate speech transcoding tests

As an alternative to the use of the 104 kbit/s interface marked as x and x' in the figures 11.24-2 and 3, the A-Interface marked as z and z' at a level of 64 kbit/s can be used for transcoder testing. In this case no special test interface or test mode is required at the transcoder and the test can be performed in operational mode.

Except for the use of interface z/z' and the appropriate test sequences, the tests are identical to the ones described in subclause 5.1. Interfaces x and x' and the conversion tests between 104 kbit/s and 64 kbit/s are not necessary in this case.

All tests for conversion from and to 104 kbit/s can alternatively be substituted by tests from and to A- or μ -law compressed speech at 64 kbit/s. The specifications are same as described above.

6 Test descriptions for full rate data rate adaption functions

The GSM system has clearly defined processes designed to carry standard data rates associated with the current range of data communications equipment. Fundamentally, the philosophy is based on the ISDN system in which CCITT V.110 [21] 80 bit frames are used to carry data from V24 based equipment. However, in a GSM link the V.110 frames are modified in a manner appropriate to the link's capacity. The radio interface uses modified 60 bit or 36 bit V.110 frames. They are used as follows:

Modified V.110 60bit frame at 12 kbit/s bearer rate carries:

- 9,6 kbit/s transparent data
- 9,6 kbit/s non transparent data
- 4,8 kbit/s transparent
- 4,8 kbit/s non transparent

Modified V.110 36 bit frame carries:

- 2 400, 1 200, 600, 300, 75 bits/s transparent

NOTE: The RA0 functions adapts both 75 bit/s and 300 bit/s to a 600 bit/s stream by the addition of stop elements (GSM 04.21 [3] clause 2.1).

Rate adaption functions in data link between the MSC and radio interface are:

RA0:

Performs async to sync conversion and stop bit padding where necessary. (GSM 04.21 [3] clause 4)

RA1:

Adapts between the synchronous user rates produced by RA0 and the intermediate rates of 8 or 16 kbit/s using V.110 80 bit frames. (GSM 04.21 [3] clause 5)

RA1':

Adapts between the synchronous user data rates, or the output of the RA0 function and the radio interface data rates of 3,6, 6 or 12 kbit/s. Modified V.110 60 bit frames are used at 12 and 6 kbit/s. Modified V.110 36 bit frames are used at 3,6 kbit/s. (GSM 04.21 [3] clause 8)

RA1/RA1':

Converts between the V.110 80 bit frames at 8 or 16 kbit/s and the radio interface data rates of 12, 6 or 3,6 kbit/s, which use modified V.110 60 bit or 36 bit frames. (GSM 04.21 [3] clause 7)

RA2:

Adapts between the intermediate rates of 8 or 16 kbit/s and the 64 kbit/s rate used at the S interface.

RAA:

Converts between the V.110 80 bit frame format and the 72 bit TRAU modified V.110 frame format (08.60 [17] clause 4.7.1). A TRAU frame consists of 320 bits and therefore can accommodate 4 x 72 bit V.110 frames which gives 288 bits. The remaining 32 bits are used for control and flags (08.60 [17] clause 3.5).

Case with TRAU at Radio interface:

The rate adaptation functions in the BSS convert the radio interface data bearer rates to the 64 kbit/s at the A-interface, and vice versa. The radio interface bearer rates may be 3,6, 6 or 12 kbit/s corresponding to user data rates of $\leq 2,4$ kbit/s, or 4,8 and 9,6 kbit/s, respectively.

The rate adaptation consists of 2 steps. The RA1/RA1' function adapts the radio interface data rates to an intermediate rate of 8 or 16 kbit/s, or vice versa. The RA2 function adapts this intermediate rate to 64 kbit/s at the A-interface, or vice versa.

Further details about the rate adaptation functions in the BSS can be found in GSM 08.20 [13].

Case with remote TRAU:

If multiplexing of four data-channels to one 64 kbit/s link between BTS and BSC is applied, an intermediate rate adaptation function is needed. In this case the radio interface data rates are converted via the standard V.110 [21] 80 bit frame to a modified V.110 72 bit TRAU frame at 16 kbit/s at the TRAU interface, and vice versa. This function is performed by using the RA2 function and a new RAA function at the network or remote end.

At the radio end this intermediate modified V.110 72 bit frame on the TRAU interface is received and converted to 8 or 16 kbit/s V.110 80 bit frames by the RAA function. This output is then further rate adapted to 12, 6 or 3,6 kbit/s at the radio interface by the RA1/RA1' function.

The additional coding of the "TRAU" frames for control of the remote transcoder/rate adaptation at the BSC/MSC site is tested in clause 7.

6.1 Uplink rate adaptation data tests**6.1.1 Uplink rate adaptation, transparent data: radio rate to 64 kbit/s level****Test purpose**

This test is applicable to BSS types 1 and 3.

Where the transcoder exists at the radio interface, 64 kbit/s data using V.110 frames are produced from 60 bit or 36 bit V.110' frames received at the radio end. This test verifies that the RA1/RA1' and RA2 functions provide bit exact USER data after the above conversion process.

Test case**Method of test**

- a) Radio interface data rate of 12 kbit/s (9 600 bit/s transparent):

One radio interface frame consisting of a sequence of 4 modified V.110 60 bit frames according to figure 5 in GSM 04.21 [3] shall be input to the BSS on the dedicated TCH. The user data shall be

pseudo-random. The received data on the 64 kbit/s interface at position Z shall be recorded. This test is performed for 9,6 kbit/s transparent data.

- b) Radio interface data rate of 6 kbit/s (4 800bit/s transparent):

One radio interface frame consisting of a sequence of 4 modified V.110 60 bit frames according to figure 6 in GSM 04.21 [3] shall be input to the BSS on the dedicated TCH. The user data shall be pseudo-random. The received data on the 64 kbit/s interface at position Z shall be recorded. The test is performed for 4,8 kbit/s transparent data.

- c) Radio interface data rate of 3,6 kbit/s ($\leq 2\ 400$ bit/s transparent):

One radio interface frame consisting of a sequence of 4 modified V.110 36 bit frames according to figures 7 or 8 or 9 (depending on net data rate required) in GSM 04.21 [3] shall be input to the BSS on the dedicated TCH. The user data shall be pseudo-random. The received data on the 64 kbit/s interface shall be recorded. The test shall be performed for 2 400, 1 200 and 600 bit/s transparent data.

Test Requirements

- a) The received data shall correspond to the bit coding as determined by the V.110 80 bit frame structure with the mapping described in clause 7.1 of GSM 04.21 [3]. In the 64 kbit/s bitstream output, bit positions 1 and 2 in each octet correspond to the received V.110 [21] 80 bit frame. All other "unused" bits shall be binary "1".
- b) The received data shall correspond to the bit coding as determined by the V.110 80 bit frame structure with the mapping described in clause 7.2 in GSM 04.21 [3]. In the 64 kbit/s bitstream output, bit position 1 in each octet corresponds to the received V.110 80 bit frame. All other "unused" bits shall be binary "1".
- c) As b) except that the received data shall correspond to the transmitted data according to clause 7.3 in GSM 04.21 [3].

In all cases the received user data shall be bit-exact.

Conformance requirement

For base station types where the transcoding is performed at the radio interface the 60 bit or 36 bit V.110' frames used on the radio interface are converted to 80bit V.110 frames at 16 kbit/s or 8 kbit/s by the RA1/RA1' function. This output is then converted to 64 kbit/s level (used on the S interface) by the RA2 function. This test deals with the combined action of the RA1/RA1' and RA2 functions.

Requirement reference

GSM 04.21 [3] clauses 7.1, 7.2 and 7.3

6.1.2 Uplink rate adaptation, transparent data - radio rate to 16kbit/s conversion

Test purpose

This test is applicable to BSS types 2, 4, 5, 6 & 7.

To verify that the radio interface data rates of 12, 6 and 3,6 kbit/s bearing modified V.110 60 bit frames are transformed to the 16 kbit/s rate bearing modified 72 bit frames within TRAU frames.

Test case

Method of test

- a) Radio interface data rate of 12 kbit/s (9 600 bit/s transparent data)

One radio interface frame conditioned for 9 600 bit/s and consisting of a sequence of 4 modified V.110 60 bit frames according to figure 5 in GSM 04.21 [3] shall be input to the BTS on the dedicated TCH. The user data shall be pseudo-random. The received data on the Abis-interface (position T) shall be recorded.

- b) Radio interface data rate of 6 kbit/s (4 800 bit/s transparent data)

One radio interface frame conditioned for 4 800 bit/s and consisting of a sequence of 4 modified V.110 60 bit frames according to figure 6 in GSM 04.21 [3] shall be input to the BTS on the dedicated TCH. The user data shall be pseudo-random. The received data on the Abis-interface (position T) shall be recorded.

- c) Radio interface data rate of 3,6 kbit/s (=< 2 400 bit/s transparent data)

One radio interface frame conditioned for 2 400 bit/s and consisting of a sequence of 4 modified V.110 36 bit frames according to figure 7 in GSM 04.21 [3] shall be input to the BTS on the dedicated TCH. The user data shall be pseudo-random. The received data on the Abis-interface shall be recorded.

The test shall be repeated for 1 200 and 600 bit/s.

Test Requirements

- a) The received data shall correspond to the transmitted data according to the modified V.110 72 bit frame, transformed via the V.110 80 bit frame, as stated in clause 4.7.1 in GSM 08.60 [17]. The mapping shall be as stated in clause 7.1 in GSM 04.21 [3]. The received user data shall be bit-exact.
- b) As in a) except that the mapping shall be as stated in clause 7.2 in GSM 04.21 [3].
- c) As b) except that the mapping shall be as stated in clause 7.3 in GSM 04.21 [3].

Conformance requirement

For base station types where transcoding is performed remote from the radio interface the CCU is required to convert the 12, 6 and 3,6 kbit/s net data rates on the radio interface to the 16 kbit/s rate on the Abis-interface (position T). This is done by first transforming the modified V.110 60 or 36 bit frames to V.110 80 bit frames using the RA1/RA1' function and then converting them to modified V.110 72 bit frames for the 16 kbit/s TRAU link using the RAA function.

Requirement reference

GSM 04.21 [3] clause 7
GSM 08.60 [17] clause 4.7.1

6.1.3 Uplink rate adaption, transparent data: 16 kbit/s to 64 kbit/s

Test purpose

This test is applicable to BSS types 2, 4, 5, 6 & 7.

To verify that the modified V.110 72 bit frame at the TRAU interface is transformed to the V.110 80 bit frame at the 64 kbit/s level (position Z).

Test case

Method of test

The TRAU under test shall be put into the data mode appropriate for each test by setting the control bits in the uplink TRAU frames, whose user data content is described below, to values appropriate for the test

being conducted. Further, one TRAU frame with no useful user data content will be required as the first frame of each test in order for the TRAU to gain synchronisation to test data and enter the data mode appropriate for each test. The control bits of this first frame must be the same as those in the test frame.

a) 9 600 bit/s transparent data

One modified V.110 72 bit frame shall be transmitted uplink at position T. The control bits of the TRAU frame in this test shall be set to frame = data, channel = full rate, intermediate RA bit rate = 16k. The received data at position Z shall be recorded.

b) 4 800 bit/s transparent data

One modified V.110 72 bit frame shall be transmitted uplink at position T. The control bits of the TRAU frame in this test shall be set to frame = data, channel = full rate, intermediate RA bit rate = 8k. The received data at position Z shall be recorded.

c) 2 400 bit/s transparent data

One modified V.110 72 bit frame shall be transmitted uplink at position T. The control bits of the TRAU frame in this test shall be set to frame = data, channel = full rate, intermediate RA bit rate = 8k. The received data at position Z shall be recorded.

Step c) shall be repeated for 1 200 bit/s and 600 bit/s.

Test Requirements

- a-c) The received data shall correspond to the transmitted data according to the V.110 80 bit frame as stated in clause 7.1-7.3 respectively in GSM 04.21 [3]. In the 64 kbit/s bitstream at position Z, bit positions 1 and 2 in each octet corresponds to the received V.110 80 bit frame in case a). All other "unused" bits shall be binary "1". In case b and c) bit position 1 in each octet corresponds to the received V.110 80 bit frame. All other "unused" bits shall be binary "1".

In all cases the received user data shall be bit-exact.

Conformance requirement

For base station types where transcoding is performed remote from the radio interface the TRAU receives a 16kbit/s or 8kbit/s bitstreams made up of modified V.110 72 bit frames. These frames are then altered to V.110 80 bit frames by the functional entities RAA and RA2. RAA generates V.110 frames on a 16 or 8 kbit/s bitstream and RA2 converts this to V.110 80bit frames on a 64 kbit/s bitstream.

Requirement reference

GSM 04.21 [3] clause 7
GSM 08.60 [17] clause 4.7.1

6.1.4 Uplink rate adaptation, non-transparent data: radio rates to 64 kbit/s

Test purpose

This test is applicable to BSS types 1 and 3.

To verify that the RA1/RA1' and RA2 functions correctly convert the modified V.110 60 or 36 bit frames from the radio interface to V.110 80 bit frames at 64 kbit/s with the necessary modifications relating to non-transparent data.

Test case**Method of test**

Radio interface data rate of 12 or 6 kbit/s:

The same method as for transparent data shall be used. However the Radio Link Protocol (RLP) shall consist of four modified V.110 60 bit frames for non-transparent data according to figure 3 in GSM 08.20 [13].

The test shall be repeated with no radio input on the radio interface (uplink DTX).

Test requirements

The received data at the 64 kbit/s level (position Z) shall correspond to the transmitted data according to the modified V.110 80 bit frame for non-transparent data stated in figure 2 in GSM 08.20 [13]. The output modified V.110 60 bit frames are derived from the mapping given in clause 7.1/7.2 in GSM 04.21 [3] with modifications given in clause 9 of 04.21 [3]. The value of E2 E3 shall be 0 0, 0 1, 1 0 and 1 1 respectively for the first, second, third and fourth 80 bit frame in the RLP frame. The E1 bit shall have the value 0 in all the four consecutive 80 bit frames relating to the RLP frame, independent of DTX is applied or not.

The received user data shall be bit-exact.

In the case of uplink DTX being applied on the radio interface, the BSS will interpret whatever it receives as data. Therefore, the data bits in the modified V.110 frames shall be indeterminate.

Conformance requirement

In the case of non-transparent data services the RA1/RA1' function performs the mapping as that used for transparent data, using 12 and 6 kbit/s radio interface data rates, with some modifications.

Requirement reference

GSM 08.20 [13] clause 4
GSM 04.21 [3] clause 7

6.1.5 Uplink rate adaptation, non-transparent data: radio rate to 16kbit/s conversion**Test purpose**

This test is applicable to BSS types 2, 4, 5, 6 & 7.

To verify that the radio interface data rates of 12 and 6 kbit/s bearing modified V.110 60 bit frames are transformed to the 16 kbit/s rate bearing modified 72 bit frames within TRAU frames with the modifications for non-transparent data.

Test case**Method of test**

- a) Radio interface data rate of 12 kbit/s (9 600 bit/s non-transparent data)

One RLP frame consisting of a sequence of four modified V.110 60 bit frames for non-transparent data according to figure 3 in GSM 08.20 [13] shall be input to the BTS on the dedicated TCH. The user data shall be pseudo-random. The received data on the TRAU interface shall be recorded.

If DTX is possible the test shall be repeated with no radio input on the radio interface (uplink DTX).

- b) Radio interface data rate of 6 kbit/s (4 800 bit/s non-transparent data)

One RLP frame consisting of a sequence of four modified V.110 60 bit frames for non-transparent data according to figure 3 in GSM 08.20 [13] shall be input to the BTS on the dedicated TCH. The user data shall be pseudo-random. The received data on the TRAU interface shall be recorded.

If DTX is possible the test shall be repeated with no radio input on the radio interface (uplink DTX).

Test Requirements

- a) The received raw data extracted from the modified V.110 72 bit frame shall have a bit exact correspondence with the input user data and show the control bit modifications described in clause 4 of GSM 08.20 [13]. The V.110 72 bit frame is derived from the 80 bit frame as shown in figure 2 of GSM 08.20 [13].

In the case of uplink DTX being applied on the radio interface, the BTS will interpret whatever it receives as data. Therefore, the data bits in the TRAU frames will be indeterminate.

- b) As in a).

Conformance requirement

For non transparent data transmission the 12 or 6 kbit/s bearer data rates used on the radio interface carry 9 600 or 4 800 bit/s non transparent data. The modified V.110 60 bit frames used are defined in figure 10 of GSM 04.21. These are first converted by the RA1/RA1' function to modified 80 bit frames at (16 or 8 kbit/s) for non transparent data as in figure 2 of 08.20 [13]. The they are converted to 72 bit V.110 frames as defined by 08.60 [17] clause 4.7.

Requirement reference

GSM 04.21 [3] clause 7

GSM 08.60 [17] clause 4.7.6

GSM 08.20 [13] figures 2 and 3

6.1.6 Uplink rate adaption, non-transparent data: 16 kbit/s to 64 kbit/s

Test purpose

This test is applicable to BSS types 2, 4, 5, 6 & 7.

To verify that the modified V.110 72 bit frame at the Abis-interface is transformed to the V.110 80 bit frame at the 64 kbit/s level (position Z) with the modifications for non-transparent data.

Test case

Method of test

The TRAU under test shall be put into the data mode appropriate for each test by setting the control bits in the uplink TRAU frames, whose user data content is described below, to values appropriate for the test being conducted. Further, one TRAU frame with no useful user data content will be required as the first frame of each test in order for the TRAU to gain synchronisation to test data and enter the data mode appropriate for each test. The control bits of this first frame must be the same as those in the test frame.

- a) 9 600 bit/s non-transparent data

One RLP frame consisting of a sequence of four modified V.110 72 bit frames shall be transmitted at position T. The control bits of the TRAU frame in this test shall be set to frame = data, channel = full rate, intermediate RA bit rate = 16k. The received data at position Z shall be recorded.

- b) 4 800 bit/s non-transparent data

One RLP frame consisting of a sequence of four modified V.110 72 bit frame shall be transmitted at position T. The control bits of the TRAU frame in this test shall be set to frame = data, channel = full rate, intermediate RA bit rate = 8k. The received data at position Z shall be recorded.

Test Requirements

- d) The received data at the 64 kbit/s level in position Z shall correspond to the transmitted data according to the modified V.110 80 bit frame for non-transparent data stated in figure 2 in GSM 08.20 [13].

In all cases the received user data shall be bit-exact.

Conformance requirement

For base station types where transcoding is performed remote from the radio interface the TRAU receives a 16kbit/s or 8kbit/s bitstreams made up of modified V.110 72 bit frames. These frames are then altered to modified (for non-transparent data) V.110 80 bit frames by the functional entities RAA and RA2. RAA generates V.110 frames on a 16 or 8 kbit/s bitstream and RA2 converts this to V.110 80bit frames on a 64 kbit/s bitstream.

Requirement reference

GSM 04.21 [3] clause 6
 GSM 08.20 [13] clause 4
 GSM 08.60 [17] clause 4.7.1

6.2 Downlink rate adaptation data tests

6.2.1 Downlink rate adaptation, transparent data : 64 kbit/s to radio rates

Test purpose

This test is applicable to BSS types 1 and 3.

To verify that the data content of the 64 kbit/s data rate (CCITT 80bit frames at 16 or 8 kbit/s input to RA2) is converted to V.110' 60 or 36 bit frame (output of RA1'/RA1) at radio interface data rates of 12,6 or 3,6 kbit/s.

Test case

Method of test

- a) Radio interface data rate of 12 kbit/s:

A sequence of 4 V.110 80 bit frames according to figure 3 in GSM 04.21 shall be input at the 64 kbit/s level at position Z. The coding of data rates shall be according to figure 4 in GSM 04.21. The bit positions 1 and 2 in each octet of the 64 kbit/s bitstream shall correspond to the content of the V.110 frame, and all the unused bits in the octet shall be set to binary "1". The user data shall be pseudo-random. The received data on the radio interface shall be recorded.

The test shall be repeated with the unused bits random.

- b) Radio interface data rate of 6 kbit/s:

As a) except that only bit position 1 in each octet of the 64 kbit/s bitstream shall correspond to the V.110 frame, and all other unused bits shall be set to binary "1".

- c) Radio interface data rate of 3,6 kbit/s:

As b) above.

Test requirements

- a) The received data shall correspond to the modified V.110 60 bit frame according to clause 5.1 in GSM 04.21 [3] whatever the contents of the unused bits.
- b) The received data shall correspond to the modified V.110 60 bit frame according to clause 5.2 in GSM 04.21 [3].
- c) The received data shall correspond to the modified V.110 36 bit frame according to clause 5.3 in GSM 04.21 [3].

In all cases the received user data shall be bit-exact.

Conformance requirement

The 64 kbit/s bitstream on the A-interface is transformed via the V.110 80 bit frame via an intermediate rate of 16 or 8 kbit/s, to the modified V.110 60 bit frame or 36 bit frame at radio interface data rates of 12, 6 or 3,6 kbit/s.

Requirement reference

GSM 04.21 [3] clauses 5.1, 5.2 and 5.3.

6.2.2 Downlink rate adaptation, transparent data - 64 kbit/s to 16 kbit/s conversion

Test purpose

This test is applicable to BSS types 2, 4, 5, 6, and 7.

To verify that the data content of the V.110 80 bit frames at 64 kbit/s (input to RA2) is converted to the modified V.110 72 bit frame (output of RAA) at 16 kbit/s.

Test case

Method of test

The TRAU may be put into test mode in order to loose its uplink TRAU control elements. Alternatively, uplink TRAU frames with control bits set to frame = data, channel = full rate and intermediate RA bit rate = 16k (cases a & d) or 8k (cases b & c) may be sent before and during each test in order to place and maintain the TRAU in the data mode appropriate for each test.

- a) Radio interface data rate of 12 kbit/s (transparent data)

A sequence of 4 V.110 80 bit frames conditioned for 9 600 bit/s (according to figure 3 in GSM 04.21 [3]) shall be input at position Z. The coding of data rates shall be according to figure 4 in GSM 04.21 [3]. The bit positions 1 and 2 in each octet of the 64 kbit/s bitstream shall correspond to the content of the V.110 80 bit frame, and all the unused bits in the octet shall be set to binary "1". The user data shall be pseudo-random. The received data on the TRAU interface (position T) shall be recorded.

- b) Radio interface data rate of 6 kbit/s (transparent data)

As case a) except that only bit position 1 in each octet of the 64 kbit/s bitstream shall correspond to the V.110 80 bit frame, and all other unused bits shall be set to binary "1". In addition the V.110 frames shall carry 4 800 bit/s data.

- c) Radio interface data rate of 3,6 kbit/s (transparent data)

As case b) above.

The test shall be conducted for 2 400, 1 200 and 600 bit/s.

Test Requirements

- a-c) The received data shall correspond to the transmitted data according to the modified V.110 72 bit frame as stated in clause 4.7.1 in GSM 08.60 [17]. The received user data shall be bit-exact. One TRAU frame contains 4 V.110 frames, of which all 4 are used for test (a) and the 1st and 3rd only are used for tests (b) & (c)

Conformance requirement

The 64 kbit/s bitstream bearing V.110 80 bit frames is transformed to the modified V.110 72 bit frame at the rate of 16 kbit/s at the TRAU interface. The conversion process involves generating V.110 80 bit frames at 16 or 8 kbit/s by means of the RA2 function and then producing modified V.110 72 bit frames in a TRAU frame.

Requirement reference

GSM 08.60 [17] clause 4.7

GSM 04.21 [3] clause 9

6.2.3 Downlink rate adaptation, transparent data: 16 kbit/s to radio rate

Test purpose

This test is applicable to BSS types 2, 4, 5, 6 and 7.

To verify that the data content of the 16 kbit/s data rate (modified V.110 72 bit frames at 16 or 8 kbit/s) at the TRAU interface is converted to the modified V.110 60 bit or 36 bit frame at 12, 6 or 3,6 kbit/s for radio transmission.

Test case

Method of test

- a) For radio interface data rate of 12 kbit/s (trans. data)

Four modified V.110 72 bit frames conditioned for 9 600 bit/s data transmission shall be input at the TRAU interface. The received data at the radio interface shall be recorded.

- b) For radio interface data rate of 6 kbit/s (trans. data)

Four modified V.110 72 bit frames conditioned for 4 800 bit/s data transmission shall be input at the TRAU interface. The received data at the radio interface shall be recorded.

- c) For radio interface data rate of 3,6 kbit/s (trans. data)

Four modified V.110 72 bit frames conditioned for 2 400 bit/s data transmission shall be input at the TRAU interface. The received data at the radio interface shall be recorded. The test is repeated for 1 200 and 600 bit/s.

Test requirements

- a) The received data shall correspond to the modified V.110 60 bit frame according to clause 7.1 in GSM 04.21 [3].
- b) The received data shall correspond to the modified V.110 60 bit frame according to clause 7.2 in GSM 04.21 [3].
- c) The received data shall correspond to the modified V.110 36 bit frame according to clause 7.3 in GSM 04.21 [3].

In all cases the received user data shall be bit-exact.

Conformance requirement

The modified V.110 72 bit frame at the TRAU interface at a rate of 16 kbit/s shall be transformed, via the V.110 80 bit frame, to the modified V.110 60 bit frame or 36 bit frame at a radio interface data rate of 12, 6 or 3,6 kbit/s.

Requirement reference

GSM 04.21 [3] clause 7
GSM 08.60 [17] clause 4.7

6.2.4 Downlink rate adaptation, non-transparent data: 64 kbit/s to radio rates conversion

Test purpose

This test is applicable to BSS types 1 and 3.

To verify that the RA2 and RA1/RA1' functions operate correctly when converting modified V.110 80 bit frames (for non transparent data) to modified V.110' 60 or 36 bit frame at a radio interface data rate of 12, 6 or 3,6 kbit/s with the necessary modifications relating to non-transparent data.

Test case

Method of test

The same method as for transparent data shall be used, however the transmitted RLP frame at the A-interface shall consist of four modified V.110 80 bit frames for non-transparent data according to figure 2 in GSM 08.20 [13].

If DTX is possible the test shall be repeated with DTX active in the BSS and setting the E1 bits to "1" in all 4 consecutive modified V.110 frames corresponding to 1 RLP frame to which DTX may be applied.

Test Requirements

The received data on the radio interface shall correspond to the modified V.110 60 bit frame for non-transparent data according to figure 3 in GSM 08.20 [13].

The received user data shall be bit-exact.

In the case of DTX being active and the E1 bits are set to "1", no frame shall be transmitted on the radio interface.

NOTE: The RLP Layer 2 functionality is handled by a separate interworking function in the network and is not a part of this BSS specification.

Conformance requirement

Non transparent data at 64 kbit/s (position Z) is borne by a modified V.110 80 bit frame. This is first converted to an intermediate rate of 16 or 8 kbit/s and then to the modified V.110 60 bit frame or 36 bit frame at a radio interface data rate of 12, 6 or 3,6 kbit/s. The frame structures for input and output are given in GSM 08.20 [13] figures 2 and 3 respectively.

Requirement reference

GSM 08.20 [13] clause 6
GSM 04.21 [3] clause 7

6.2.5 Downlink rate adaptation, non-transparent data - 64 kbit/s to 16 kbit/s conversion

Test purpose

This test is applicable to BSS types 2, 4, 5, 6, and 7.

To verify that the data content of the V.110 80 bit frames at 64 kbit/s (input to RA2) is converted to the modified V.110 72 bit frame (output of RAA) at 16 kbit/s with modifications relating to non-transparent data.

Test case

Method of test

The TRAU may be put into test mode in order to loose its uplink TRAU control elements. Alternatively, uplink TRAU frames with control bits set to frame = data, channel = full rate and intermediate RA bit rate = 16k (cases a & d) or 8k (cases b & c) may be sent before and during each test in order to place and maintain the TRAU in the data mode appropriate for each test.

- a) Radio interface data rate of 12 kbit/s (9 600 bit/s non-transparent data)

One RLP frame consisting of a sequence of 4 V.110 80 bit frames conditioned for 9 600 bit/s (according to figure 2 in GSM 08.20 [13]) shall be input at position Z. The received data on the TRAU interface shall be monitored.

If DTX is possible the test shall be repeated with DTX active in the BSC and setting the E1 bits to 1 in all 4 consecutive modified V.110 frames corresponding to 1 RLP frame to which DTX may be applied.

- b) Radio interface data rate of 6 kbit/s (4 800 non-transparent data)

As case a) above.

Test Requirements

- a-b) The received data shall correspond to the transmitted data according to the modified V.110 72 bit frame as stated in clause 4.7.1 in GSM 08.60 [17]. The received user data shall be bit-exact. One TRAU frame contains 4 V.110 frames, of which all 4 are used for test (a) and the 1st and 3rd only are used for tests (b) The E1 bits shall be transferred transparently independent of whether DTX is used or not.

Conformance requirement

The 64 kbit/s bitstream bearing V.110 80 bit frames is transformed to the modified V.110 72 bit frame at the rate of 16 kbit/s at the TRAU interface. The conversion process involves generating V.110 80 bit frames at 16 or 8 kbit/s by means of the RA2 function and then producing modified V.110 72 bit frames in a TRAU frame. Modifications relating to non-transparent data frothe coding of the V.110 80 bit frame are given in clause 6 of GSM 08.20 [13].

Requirement reference

GSM 08.60 [17] clause 4.7

GSM 04.21 [3] clause 6

GSM 08.20 [13] clause 6

6.2.6 Downlink rate adaptation, non-transparent data: 16 kbit/s to radio rate

Test purpose

This test is applicable to BSS types 2, 4, 5, 6, and 7.

To verify that the data content of the 16 kbit/s data rate (modified V.110 72 bit frames at 16 or 8 kbit/s) at the TRAU interface is converted to the modified V.110 60 bit frame at 12 or 6 kbit/s for radio transmission with adjustments for non-transparent data handling.

Test case

Method of test

- a) For radio interface data rate of 12 kbit/s (9 600 bit/s non-trans. data)

One TRAU frame containing an RLP frame consisting of four modified V.110 72 bit frames for non-transparent data shall be input at the TRAU interface. The received data on the radio interface shall be recorded.

If DTX is possible the test shall be repeated with DTX active in the BTS and setting all the E1 bits in the TRAU frames to 1.

- b) For radio interface data rate of 6 kbit/s (4 800 bit/s non-trans. data)

As in a) above.

Test requirements

- a) The received data shall correspond to the modified V.110 60 bit frame for non-transparent data according to figure 3 in GSM 08.20 [13], and the mapping stated in clause 9 of GSM 04.21 [3].

In the case of DTX being active in the BTS and the E1 bits are set to 1, no frame shall be transmitted on the radio interface.

- b) As in a) above.

In all cases the received user data shall be bit-exact.

Conformance requirement

The modified V.110 72 bit frame at the TRAU interface at a rate of 16 kbit/s shall be transformed, via the V.110 80 bit frame, to the modified V.110 60 bit frame with modifications for non transparent data as described in clause 7 of 04.21 [3].

Requirement reference

GSM 04.21 [3] clause 9
GSM 08.60 [17] clause 4.7.6
GSM 08.20 [13] clause 6.

Annex A (informative): Change history

This annex lists all change requests approved for the present document since the first phase 2 version was approved by ETSI SMG.

SMG#	SMG tdoc	SMG8 tdoc	VERS	CR	RV	PH	CAT	SUBJECT	Resulting Version
s20	605/96		4.0.0	A003		2	F	Static time alignment	4.1.0
s25	98-0167	98p006	4.1.0	A004		2	B	Addition of tests to incorporate HR, EFR and 8-bit PCM tests	4.2.0
s27	98-0740	98p110	4.2.0	A005		2	F	Clarification of tests which can be made via the radio interface	4.3.0
			4.3.0					Version update for publication	4.3.1

History

Document history			
November 1996	Public Enquiry	PE 117:	1996-11-04 to 1997-02-28
November 1998	Vote	V 9903:	1998-11-17 to 1999-01-15
January 1999	First Edition		