

3GPP TS 11.21 V8.11.0 (2009-05)

Technical Specification

**3rd Generation Partnership Project;
Technical Specification Group GSM/EDGE
Radio Access Network;
Base Station System (BSS) equipment specification;
Radio aspects
(Release 1999)**



The present document has been developed within the 3rd Generation Partnership Project (3GPP™) and may be further elaborated for the purposes of 3GPP.

The present document has not been subject to any approval process by the 3GPP Organisational Partners and shall not be implemented. This Specification is provided for future development work within 3GPP only. The Organisational Partners accept no liability for any use of this Specification. Specifications and reports for implementation of the 3GPP™ system should be obtained via the 3GPP Organisational Partners' Publications Offices.

Keywords

GSM, BSS, radio

3GPP

Postal address

3GPP support office address

650 Route des Lucioles - Sophia Antipolis
Valbonne - FRANCE
Tel.: +33 4 92 94 42 00 Fax: +33 4 93 65 47 16

Internet

<http://www.3gpp.org>

Copyright Notification

No part may be reproduced except as authorized by written permission.
The copyright and the foregoing restriction extend to reproduction in all media.

© 2009, 3GPP Organizational Partners (ARIB, ATIS, CCSA, ETSI, TTA, TTC).
All rights reserved.

UMTS™ is a Trade Mark of ETSI registered for the benefit of its members
3GPP™ is a Trade Mark of ETSI registered for the benefit of its Members and of the 3GPP Organizational Partners
LTE™ is a Trade Mark of ETSI currently being registered for the benefit of its Members and of the 3GPP Organizational Partners
GSM® and the GSM logo are registered and owned by the GSM Association

Contents

Foreword	8
1 Scope	9
2 References.....	10
3 Definitions, abbreviations, frequency bands and channels	11
3.1 Definitions	11
3.2 Abbreviations.....	12
3.3 Frequency bands and channels.....	12
3.3.1 Frequency bands.....	12
3.3.2 Channels and channel numbering.....	13
4 General test conditions and declarations	13
4.1 Output power and determination of power class.....	13
4.2 Specified frequency range.....	14
4.3 Frequency hopping.....	14
4.4 RF power control.....	14
4.5 Downlink discontinuous transmission (DTX).....	14
4.6 Test environments	15
4.6.1 Normal test environment.....	15
4.6.2 Extreme test environment.....	15
4.6.2.1 Extreme temperature	15
4.6.3 Vibration.....	16
4.6.4 Power supply.....	16
4.7 Acceptable uncertainty of measurement equipment.....	16
4.8 Interpretation of measurement results.....	20
4.9 Selection of configurations for testing.....	20
4.10 BTS Configurations	21
4.10.1 Receiver diversity.....	21
4.10.2 Duplexers.....	21
4.10.3 Power supply options	22
4.10.4 Ancillary RF amplifiers.....	22
4.10.5 BSS using antenna arrays	23
4.10.6 BTS supporting 8-PSK modulation	24
5 Format and interpretation of tests	24
6 Transmitter	25
6.1 Static Layer 1 functions.....	25
6.1.1 Test purpose.....	25
6.1.2 Test case.....	25
6.1.3 Essential conformance.....	25
6.1.4 Complete conformance	25
6.1.5 Requirement reference	26
6.2 Modulation accuracy.....	26
6.2.1 Test purpose.....	26
6.2.2 Test case.....	26
6.2.3 Essential conformance.....	27
6.2.4 Complete conformance	28
6.2.5 Requirement reference	28
6.3 Mean transmitted RF carrier power.....	28
6.3.1 Test purpose.....	28
6.3.2 Test case.....	28
6.3.3 Essential conformance.....	29
6.3.4 Complete conformance	30
6.3.5 Requirement reference	30
6.4 Transmitted RF carrier power versus time	30
6.4.1 Test purpose.....	30

6.4.2	Test case.....	30
6.4.3	Essential conformance.....	31
6.4.4	Complete conformance	31
6.4.5	Requirement reference	33
6.5	Adjacent channel power	33
6.5.1	Spectrum due to modulation and wideband noise.....	33
6.5.1.1	Test purpose.....	33
6.5.1.2	Test case.....	33
6.5.1.3	Essential Conformance	34
6.5.1.4	Complete conformance	36
6.5.1.5	Requirement reference	36
6.5.2	Switching transients spectrum	36
6.5.2.1	Test purpose.....	36
6.5.2.2	Test case.....	36
6.5.2.3	Essential conformance	38
6.5.2.4	Complete conformance	38
6.5.2.5	Requirement reference	38
6.6	Spurious emissions from the transmitter antenna connector.....	38
6.6.1	Conducted spurious emissions from the transmitter antenna connector, inside the BTS transmit band.....	39
6.6.1.1	Test Purpose.....	39
6.6.1.2	Test Case.....	39
6.6.1.3	Essential conformance	39
6.6.1.4	Complete conformance	39
6.6.1.5	Requirement Reference.....	39
6.6.2	Conducted spurious emissions from the transmitter antenna connector, outside the BTS transmit band.....	39
6.6.2.1	Applicability (Phase 2)	39
6.6.2.1.1	Test Purpose.....	40
6.6.2.1.2	Test Case.....	40
6.6.2.1.3	Essential conformance	41
6.6.2.1.4	Complete conformance	41
6.6.2.1.5	Requirement Reference.....	41
6.6.2.2	Applicability (Phase 2+)	41
6.6.2.2.1	Test Purpose.....	41
6.6.2.2.2	Test Case.....	42
6.6.2.2.3	Essential conformance	43
6.6.2.2.4	Complete conformance	43
6.6.2.2.5	Requirement Reference.....	44
6.6.2.3	Applicability (Phase 2+ Release 1999 GSM 400, GSM 900 and DCS 1800)	44
6.6.2.3.1	Test Purpose.....	44
6.6.2.3.2	Test Case.....	44
6.6.2.3.3	Essential conformance	45
6.6.2.3.4	Complete conformance	45
6.6.2.3.5	Requirement Reference.....	45
6.7	Intermodulation attenuation (GSM 400, GSM 900 and DCS 1800)	45
6.7.1	Test purpose.....	45
6.7.2	Test case.....	46
6.7.3	Essential Conformance.....	46
6.7.4	Complete conformance	47
6.7.5	Requirement reference	48
6.8	Intra Base Station System intermodulation attenuation	48
6.8.1	Test purpose.....	48
6.8.2	Test case.....	48
6.8.3	Essential conformance.....	49
6.8.4	Complete conformance	49
6.8.5	Requirement reference	50
6.9	Intra Base Station System intermodulation attenuation, MXM 850 and MXM 1900	50
6.9.1	Test purpose.....	50
6.9.2	Test cases.....	50
6.9.2.1	200 kHz carriers-only.....	50
6.9.2.2	200 kHz and ANSI-136 30 kHz carriers	50
6.9.3	Essential conformance.....	50

6.9.4	Complete conformance	51
6.9.5	Requirement reference	51
6.10	Intra Base Station System intermodulation attenuation, PCS 1900 and GSM 850	51
6.10.1	Test purpose.....	51
6.10.2	Test case.....	51
6.10.3	Essential conformance.....	52
6.10.4	Complete conformance	52
6.10.5	Requirement reference	52
6.11	Intermodulation attenuation (GSM 850, MXM 850, PCS 1900 and MXM 1900)	52
6.11.1	Test purpose.....	52
6.11.2	Test case.....	52
6.11.3	Essential Conformance.....	53
6.11.4	Complete conformance	54
6.11.5	Requirement reference	55
7	Receivers.....	55
7.1	Static Layer 1 receiver functions (nominal error ratios).....	55
7.1.1	Test Purpose.....	55
7.1.2	Test Case.....	55
7.1.3	Essential conformance.....	57
7.1.4	Complete conformance	57
7.1.5	Requirement Reference	58
7.2	Erroneous Frame Indication Performance.....	58
7.2.1	Test Purpose.....	58
7.2.2	Test Case.....	58
7.2.3	Essential conformance.....	59
7.2.4	Complete conformance	59
7.2.5	Requirement reference	59
7.3	Static Reference Sensitivity Level.....	59
7.3.1	Test Purpose.....	59
7.3.2	Test Case.....	59
7.3.3	Essential conformance.....	61
7.3.4	Complete conformance	61
7.3.5	Requirements Reference	62
7.4	Multipath Reference Sensitivity Level	63
7.4.1	Test Purpose.....	63
7.4.2	Test Case.....	63
7.4.3	Essential conformance.....	65
7.4.4	Complete conformance	66
7.4.5	Requirement Reference	70
7.5	Reference interference level	70
7.5.1	Test Purpose.....	70
7.5.2	Test Case.....	70
7.5.3	Essential conformance.....	73
7.5.4	Complete conformance	76
7.5.5	Requirements Reference	81
7.6	Blocking Characteristics	81
7.6.1	Test Purpose.....	81
7.6.2	Test Case.....	81
7.6.3	Essential conformance.....	85
7.6.4	Complete conformance	86
7.6.5	Requirements reference.....	86
7.7	Intermodulation characteristics	86
7.7.1	Test Purpose.....	86
7.7.2	Test Case.....	87
7.7.3	Essential conformance.....	88
7.7.4	Complete conformance	88
7.7.5	Requirement Reference	89
7.8	AM suppression.....	89
7.8.1	Test Purpose.....	89
7.8.2	Test Case.....	89
7.8.3	Essential conformance.....	90

7.8.4	Complete conformance	91
7.8.5	Requirement Reference	91
7.9	Spurious emissions from the receiver antenna connector.....	91
7.9.1	Test Purpose.....	91
7.9.2	Test Case.....	91
7.9.3	Essential conformance.....	91
7.9.4	Complete conformance	92
7.9.5	Requirement Reference	92
8	Radiated spurious emissions	92
8.1	Test Purpose.....	92
8.2	Test Case.....	92
8.3	Essential conformance	93
8.4	Complete conformance	94
8.5	Requirement reference	94
9	Radio link management	94
9.1	General	94
9.2	Synchronization	94
9.2.1	Timing Tolerance	95
9.2.1.1	Test purpose.....	95
9.2.1.2	Test case	95
9.2.1.3	Essential conformance	95
9.2.1.4	Complete conformance	95
9.2.1.5	Requirement reference	96
9.3	Frame structure	96
9.3.1	BCCH Multiframe	96
9.3.1.1	Test purpose.....	96
9.3.1.2	Test case	96
9.3.1.3	Essential conformance	96
9.3.1.4	Complete conformance	96
9.3.1.5	Requirement reference	96
9.3.2	TDMA-frame structure	97
9.3.2.1	Test purpose.....	97
9.3.2.2	Test case	97
9.3.2.3	Essential conformance	97
9.3.2.4	Complete conformance	97
9.3.2.5	Requirement reference	97
9.4	Radio link measurements	97
9.4.1	Signal Strength	98
9.4.1.1	Measurement Accuracy	98
9.4.1.1.1	Test purpose.....	98
9.4.1.1.2	Test case	98
9.4.1.1.3	Essential conformance	98
9.4.1.1.4	Complete conformance	98
9.4.1.2	Selectivity of signal strength measurements	99
9.4.1.2.1	Test purpose.....	99
9.4.1.2.2	Test case	99
9.4.1.2.3	Essential conformance	100
9.4.1.2.4	Complete conformance	100
9.4.1.2.5	Requirement reference	100
9.4.2	Signal quality	101
9.4.2.1	Test purpose.....	101
9.4.2.2	Test case	101
9.4.2.3	Essential conformance	101
9.4.2.4	Complete conformance	101
9.4.2.5	Requirement reference	102
9.4.3	Idle channel signal level.....	102
9.4.3.1	Test purpose.....	102
9.4.3.2	Test case	102
9.4.3.3	Essential conformance	103
9.4.3.4	Complete conformance	103

9.4.3.5	Requirement reference	103
9.5	Adaptive frame alignment.....	103
9.5.1	Test purpose.....	103
9.5.2	Test case.....	104
9.5.3	Essential conformance.....	104
9.5.4	Complete conformance	104
9.5.5	Requirement reference	105
Annex A (informative): Testing of statistical parameters		106
A.1	General theoretical methodology	106
A.2	Detailed theoretical methodology	108
A.3	Limitations and corrections to the theoretical methodology	109
A.3.1	Independent errors.....	109
A.3.2	Gaussian distribution	109
A.3.3	Stationary random processes	109
A.3.4	Low error ratios	110
A.3.5	Total corrections	110
A.4	Alternative experimental methodology	110
A.5	Detailed definition of error events	111
Annex B (informative): Description of special test equipment.....		112
B.1	Base Station System Test Equipment (BSSTE)	112
B.1.1	Fading and multipath propagation simulator	112
B.2	Measurement set ups for TX intermodulation	112
B.2.1	Test set-up for Intermodulation Attenuation (6.7.).....	112
B.2.1.1	RX-Band.....	113
B.2.1.2	Outside RX Band	113
B.2.2	Test set-up for Intra BSS Intermodulation Attenuation (6.8.)	114
B.2.2.1	RX-Band.....	114
B.2.2.2	TX-Band	114
Annex C (informative): Number of samples needed for statistical testing.....		115
C.1	GSM 900; Number of samples for testing	115
C.2	DCS 1800; Number of Samples for Testing	136
Annex D (informative): Change history.....		157

Foreword

This Technical Specification has been produced by the 3rd Generation Partnership Project (3GPP).

The contents of the present document are subject to continuing work within the TSG and may change following formal TSG approval. Should the TSG modify the contents of the present document, it will be re-released by the TSG with an identifying change of release date and an increase in version number as follows:

Version x.y.z

where:

- x the first digit:
 - 1 presented to TSG for information;
 - 2 presented to TSG for approval;
 - 3 or greater indicates TSG approved document under change control.
- y the second digit is incremented for all changes of substance, i.e. technical enhancements, corrections, updates, etc.
- z the third digit is incremented when editorial only changes have been incorporated in the document.

1 Scope

The present document specifies the Radio Frequency (RF) test methods and conformance requirements for GSM 400, GSM 900 and DCS 1800, PCS 1900, GSM 850, MXM 850 and MXM 1900 Base Station Systems (BSS)s. These have been derived from, and are consistent with, the core GSM specifications specified in the requirements reference subclause of each test with the exception that requirements expressed as a reference to regulatory documents (e.g. FCC) have not been included in the present document.

The present document is applicable to BSS meeting the requirements of either GSM Phase 2 or GSM Phase 2+. Unless otherwise stated, all tests are applicable to BSS meeting Phase 2 and/or Phase 2+ GSM requirements, because the requirements of the Phase 2 and Phase 2+ core GSM specifications which are referenced in the test are consistent. Most differences between Phase 2 and Phase 2+ requirements represent Phase 2+ features which are optional for the BSS to support.

For each test, two conformance requirements are specified:

- essential conformance requirements;
- complete conformance requirements.

Essential conformance requirements are those which are required:

- a) to ensure compatibility between the radio channels in the same cell;
- b) to ensure compatibility between cells, both co-ordinated and unco-ordinated;
- c) to ensure compatibility with existing systems in the same or adjacent frequency bands;
- d) to verify the important aspects of the transmission quality of the system.

Essential conformance requirements are sufficient to verify the performance of the equipment for radio type approval purposes, in countries where this is applicable. For GSM 850, MXM 850, PCS 1900 and MXM 1900 only the complete conformance requirements are applicable.

Complete conformance requirements may be tested to verify all aspects of the performance of a BSS. These requirements are intended to be used by manufacturers and operators to allow conformance and acceptance testing to be performed in a consistent manner; the tests to be performed should be agreed between the parties.

In some tests there are separate requirements for micro-BTS and BTS. If there is no separate requirement for a micro-BTS, the requirements for the BTS apply to a micro-BTS.

In the present document, the reference point for RF connections (except for the measurement of mean transmitted RF carrier power) is the antenna connector, as defined by the manufacturer. The present document does not apply to repeaters or RF devices which may be connected to an antenna connector of a BSS, except as specified in subclause 4.10.

NOTE: The present document contains both essential conformance requirements and complete conformance requirements. Essential conformance requirements are those requirements which may be deemed sufficient for radio type approval purposes, complete conformance requirements cover all conformance aspects.

2 References

The following documents contain provisions which, through reference in this text, constitute provisions of the present document.

- References are either specific (identified by date of publication, edition number, version number, etc.) or non-specific.
- For a specific reference, subsequent revisions do not apply.
- For a non-specific reference, the latest version applies. In the case of a reference to a 3GPP document (including a GSM document), a non-specific reference implicitly refers to the latest version of that document *in the same Release as the present document*.

- [1] 3GPP TR 01.04: "Digital cellular telecommunications system (Phase 2+); Abbreviations and acronyms".
- [2] GSM 04.22: "Digital cellular telecommunications system (Phase 2+); Radio Link Protocol (RLP) for data and telematic services on the Mobile Station - Base Station System (MS - BSS) interface and the Base Station System - Mobile-services Switching Centre (BSS - MSC) interface".
- [3] GSM 05.01: "Digital cellular telecommunications system (Phase 2); Physical layer on the radio path; General description".
- [4] GSM 05.02 (ETS 300 574): "Digital cellular telecommunications system (Phase 2); Multiplexing and multiple access on the radio path".
- [5] GSM 05.03 (ETS 300 575): "Digital cellular telecommunications system (Phase 2); Channel coding".
- [6] GSM 05.04 (ETS 300 576): "Digital cellular telecommunications system (Phase 2); Modulation".
- [7] GSM 05.05 (ETS 300 577): "Digital cellular telecommunications system (Phase 2); Radio transmission and reception".
- [8] GSM 05.08 (ETS 300 578): "Digital cellular telecommunications system (Phase 2); Radio subsystem link control".
- [9] GSM 05.10 (ETS 300 579): "Digital cellular telecommunications system (Phase 2); Radio subsystem synchronization".
- [10] 3GPP TS 08.20: "Digital cellular telecommunications system (Phase 2); Rate adaption on the Base Station System - Mobile-services Switching Centre (BSS - MSC) interface".
- [11] ETSI EN 300 019-1: "Equipment Engineering (EE); Environmental conditions and environmental tests for telecommunications equipment Part 1-0: Classification of environmental conditions Introduction".
- [12] IEC 60068-2: "Basic environmental testing procedures; Part 2: Tests".
- [13] IEC 721: "Classification of environmental conditions".
- [14] ETSI ETR 027: "Radio and Equipment Systems; methods of measurement for mobile radio equipment".
- [15] ETSI ETR 028: "Radio and Equipment Systems; Uncertainties in the measurement of mobile radio equipment characteristics".
- [16] ITU-R Rec. SM.329-7: "Spurious emissions"
- [17] 3GPP TS 04.22: "Digital cellular telecommunications system (Phase 2); Radio Link Protocol (RLP) for data and telematic services on the Mobile Station - Base Station System (MS - BSS) interface and the Base Station System - Mobile-services Switching Centre (BSS - MSC) interface".

- [18] 3GPP TS 05.01: "Digital cellular telecommunications system (Phase 2+); Physical layer on the radio path; General description".
- [19] 3GPP TS 05.02 (EN 300 908): "Digital cellular telecommunications system (Phase 2+); Multiplexing and multiple access on the radio path".
- [20] 3GPP TS 05.03: "Digital cellular telecommunications system (Phase 2+); Channel coding".
- [21] 3GPP TS 05.04: "Digital cellular telecommunications system (Phase 2+); Modulation".
- [22] 3GPP TS 05.05: "Digital cellular telecommunications system (Phase 2+); Radio transmission and reception".
- [23] 3GPP TS 05.08: "Digital cellular telecommunications system (Phase 2+); Radio subsystem link control".
- [24] 3GPP TS 05.10: "Digital cellular telecommunications system (Phase 2+); Radio subsystem synchronization".
- [25] TIA/EIA-136-C: "TDMA Third Generation Wireless".

3 Definitions, abbreviations, frequency bands and channels

3.1 Definitions

For the purposes of the present document, the following terms and definitions apply.

8-PSK: modulation type as defined GSM 05.04 [21] clause 3.

Carrier Frequency: centre of the ARFCN under test.

GMSK: modulation type as defined by GSM 05.04 [21] clause 2.

GSM: unless otherwise specified, references to GSM include GSM 400, GSM 850, GSM 900, DCS1800, PCS 1900, MXM 850 and MXM 1900.

BSS: in the present document, the term BSS (or base station subsystem) applies to both a BTS and integrated BSS. If a separate BSC is required to perform tests on a BTS, the BSC may be regarded as test equipment and the environmental conditions of the BSC need not be controlled.

pico-BTS: as defined in GSM 05.05 [22]). In the present document, this also includes a BSS which incorporates a pico-BTS.

micro-BTS: as defined in GSM 05.05 [7] and [22]). In the present document, this also includes a BSS which incorporates a micro-BTS.

MXM: mixed Mode system. Mixed-mode is defined as a network that deploys both 30 kHz RF carriers and 200 kHz RF carriers in geographic regions where the Federal Communications Commission (FCC) or similar regulations are applied. In the present document MXM 850 and MXM 1900 are defined.

normal BTS: any BTS or BSS as defined by GSM 05.05 (EN 300 910) [22] which is not a micro-BTS or Pico-BTS.

BSSTE: base Station System Test Equipment; see annex B.

manufacturer: in the present document, a reference to a manufacturer shall also apply to an agent of the manufacturer.

P-GSM: primary GSM 900 band.

E-GSM: extended GSM 900 band (includes P-GSM band).

R-GSM: Railways GSM 900 band (includes P-GSM band and E-GSM band).

GSM 400: unless otherwise specified, references to GSM 400 include GSM 450 and GSM 480 band.

Relevant TX band (or relevant transmit band): transmit band defined in subclause 3.3.1 for the frequency band of BTS declared by the manufacturer.

Relevant RX band (or relevant receive band): receive band defined in subclause 3.3.1 for the frequency band of BTS declared by the manufacturer.

Operating band: transmit and receive operating bands together comprise the frequency band supported by the BSS; (see subclause 4.2).

Circuit switched logical channels: all the standard GSM logical channels, including traffic channels (TCH), common control channels (RACH) and dedicated control channels (SDCCH, SACCH).

Packet switched logical channels: all the General Packet Radio Services (GPRS) packet data logical channels, including packet traffic channels (PDTCH and PACCH) and packet common control channels (PRACH).

GPRS: any subset of the packet traffic channels PDTCH/CS-1 to CS-4 and related control channels.

EGPRS: any subset of the packet traffic channels PDTCH/MCS-1 to MCS-9 and related control channels.

ECSD: any subset of the E-TCH traffic channels and related control channels.

3.2 Abbreviations

Unless otherwise stated, abbreviations used in the present document shall have the meaning given in GSM 01.04 (ETR 350) [1].

B	"Bottom"; the lowest frequency on which a test is performed
M	"Middle"; a frequency in the middle portion of the operating band of the BSS on which a test is performed
T	"Top"; the highest frequency on which a test is performed

3.3 Frequency bands and channels

3.3.1 Frequency bands

The frequency bands for the Base Station System are given in table 1.

Table 1: Frequency bands for GSM Base Station Systems

	TX:	RX:
P-GSM900	935 MHz to 960 MHz	890 MHz to 915 MHz
DCS1800	1 805 MHz to 1 880 MHz	1 710 MHz to 1 785 MHz
E-GSM900	925 MHz to 960 MHz	880 MHz to 915 MHz
R-GSM900	921 MHz to 960 MHz	876 MHz to 915 MHz
GSM 450	460,4 MHz to 467,6 MHz	450,4 MHz to 457,6 MHz
GSM 480	488,8 MHz to 496 MHz	478.8 MHz to 486 MHz
GSM 850 and MXM 850	869 MHz to 894 MHz	824 MHz to 849 MHz
PCS 1900 and MXM 1900	1 930 MHz to 1 990 MHz	1 850 MHz to 1 910 MHz

NOTE: It is up to the operator to choose any subset of these bands (or the complete band) on a location basis within a frequency band assigned to the operator by the authority responsible for frequency management issues.

3.3.2 Channels and channel numbering

The channel numbers (ARFCN) for the carrier frequencies (RF channels) within the frequency bands defined above (as defined in GSM 05.05 (EN 300 910) [22]), are given in table 2. $F_l(n)$ is the frequency of the centre of the RF channel n in the lower band (=RX) and $F_u(n)$ the corresponding frequency in the upper band (=TX).

Table 2: Channel Numbering: Frequencies are in MHz

P-GSM900	$F_l(n)=890+0,2*n$	$1 \leq n \leq 124$	$F_u(n)=F_l(n)+45$
E-GSM900	$F_l(n)=890+0,2*n$ $F_l(n)=890+0,2*(n-1 024)$	$0 \leq n \leq 124$ $975 \leq n \leq 1023$	$F_u(n)=F_l(n)+45$
R-GSM900	$F_l(n)=890+0,2*n$ $F_l(n)=890+0,2*(n-1 024)$	$0 \leq n \leq 124$ $955 \leq n \leq 1023$	$F_u(n)=F_l(n)+45$
DCS1800	$F_l(n)=1 710,2+0,2*(n-512)$	$512 \leq n \leq 885$	$F_u(n)=F_l(n)+95$
PCS 1900 and MXM 1900	$F_l(n)=1 850,2 + 0,2*(n-512)$	$512 \leq n \leq 810$	$F_u(n) = F_l(n) + 80$
GSM 450	$F_l(n) = 450,6 + 0,2*(n-259)$	$259 \leq n \leq 293$	$F_u(n) = F_l(n) + 10$
GSM 480	$F_l(n) = 479 + 0,2*(n-306)$	$306 \leq n \leq 340$	$F_u(n) = F_l(n) + 10$
GSM 850 and MXM 850	$F_l(n) = 824,2 + 0,2*(n-128)$	$128 \leq n \leq 251$	$F_u(n) = F_l(n) + 45$

4 General test conditions and declarations

The requirements of this clause apply to all tests in the present document, when applicable.

The general conditions during the tests should be according to the relevant parts of ETR 027 [14] (methods of measurement for mobile radio equipment) with the exceptions and additions defined in the individual tests.

Many of the tests in the present document measure a parameter relative to a value which is not fully specified in the GSM specifications. For these tests, the conformance requirement is determined relative to a nominal value specified by the manufacturer.

Certain functions of a BTS are optional in the GSM specifications.

When specified in a test, the manufacturer shall declare the nominal value of a parameter, or whether an option is supported.

4.1 Output power and determination of power class

The manufacturer shall declare the rated maximum power per TRX for each supported modulation. For a micro or pico-BTS, this shall be specified at the antenna connector. For a normal BTS, it shall be stated whether this is specified at the input to the combiner or at the antenna connector of the BSS.

For a micro-BTS, the class of the micro-BTS shall be determined from the declared maximum power, according to table 3. Where applicable, the manufacturer shall declare whether the BTS meets the requirements of a micro or pico-BTS.

For a BTS supporting 8-PSK, the manufacturer shall declare the maximum output power capability for GMSK and 8-PSK modulation. The TRX power class, the class of a micro-BTS or a pico-BTS is defined by the highest output power capability for either modulation.

Table 3: Micro and pico-BTS Power Classes

TRX power class	GSM 900, GSM 850 and MXM 850 micro and pico-BTS Maximum output power	DCS1800, PCS 1900 and MXM 1900 micro and pico-BTS Maximum output power
M1	(>19)-24 dBm	(>27)-32 dBm
M2	(>14)-19 dBm	(>22)-27 dBm
M3	(>9)-14 dBm	(>17)-22 dBm
P1	(>13)-20 dBm	(>16)-23 dBm

NOTE: For a normal BTS, the TRX power class can be determined from the manufacturers declared output power per TRX measured at the input to the combiner, according to the tables of TRX power classes in EN 300 910 [22]. The test requirements for a normal BTS do not vary in this [EN] with TRX power classes. The definition of TRX power class only relates to the declared power per TRX and does not impose any requirement on the measured output power of the BTS.

4.2 Specified frequency range

The manufacturer shall declare:

- which of the frequency bands defined in subclause 3.3.1 are supported by the BSS; a BSS may support DCS 1800, GSM 450, GSM 480, PCS 1900, MXM 1900, GSM 850, MXM 850 and one of the GSM 900 bands, but shall not be defined as supporting more than one of the GSM 900 bands;
- the frequency range within the above frequency band(s) supported by the BSS; This frequency range comprises the transmit and receive operating bands.

Many tests in the present document are performed with appropriate frequencies in the bottom, middle and top of the operating frequency band of the BTS. These are denoted as RF channels B (bottom), M (middle) and T (top).

When a test is performed by a test laboratory, the ARFCNs to be used for RF channels B, M and T shall be specified by the laboratory. The laboratory may consult with operators, the manufacturer or other bodies.

When a test is performed by a manufacturer, the ARFCNs to be used for RF channels B, M and T may be specified by an operator.

4.3 Frequency hopping

The Manufacturer shall declare whether the BSS supports Slow Frequency Hopping (SFH) and if yes, which basic implementation or implementations is supported. If SFH is supported the BSS shall be able to switch to any frequency in its operating band on a time slot per time slot basis.

Two basic implementations of SFH are possible:

- a) baseband frequency hopping: frequency hopping is done by multiplexing the data of the logical channels to different TRXs according to the hopping scheme. The TRXs are fixed tuned to a dedicated ARFCN;
- b) synthesizer frequency hopping: frequency hopping is done by tuning the TRX on a timeslot per timeslot basis. The logical channels are dedicated to a hopping TRX.

The detailed description of the frequency hopping scheme is described in GSM 05.02 (ETS 300 908) [4].

4.4 RF power control

RF power control functions ("dynamic power control") may optionally be implemented in GSM Base Station Systems according to GSM 05.08 (EN 300 911) [8] as an operator choice. If implemented, the BSS shall be able to hop between any defined power level on a time slot per time slot basis. The manufacturer shall declare how many static power steps and how many dynamic steps are supported by the BSS. The number of static power steps and the total number of power control steps may be different for GMSK and 8-PSK.

4.5 Downlink discontinuous transmission (DTX)

Downlink discontinuous transmission (DTX), as defined in the GSM 06-series of specifications for full-rate speech channels and in GSM 04.22 (ETS 300 946) [2] and GSM 08.20 [10] for non-transparent data, may optionally be implemented in the downlink BSS (transmitter) as an operator choice. All requirements in the present document, unless otherwise stated, apply whether downlink DTX is used or not.

4.6 Test environments

For each test in the present document, the environmental conditions under which the BSS is to be tested are defined:

4.6.1 Normal test environment

When a normal test environment is specified for a test, the test should be performed under any combination of conditions between the minimum and maximum limits stated in table 4.

Table 4: Limits of conditions for Normal Test Environment

Condition	Minimum	Maximum
Barometric pressure	86 kPa	106 kPa
Temperature	15°C	30°C
Relative Humidity	20 %	85 %
Power supply	Nominal, as declared by the manufacturer	
Vibration	Negligible	

The ranges of barometric pressure, temperature and humidity represent the maximum variation expected in the uncontrolled environment of a test laboratory. If it is not possible to maintain these parameters within the specified limits, the actual values shall be recorded in the test report.

NOTE: This may, for instance, be the case for measurements of radiated emissions performed on an open field test site.

4.6.2 Extreme test environment

The manufacturer shall declare one of the following:

- a) the equipment class for the equipment under test, as defined in ETS 300 019-1-3, (Equipment Engineering (EE); Environmental conditions and environmental test for telecommunications equipment, Part 1-3: Classification of environmental conditions, Stationary use at weather protected locations);
- b) the equipment class for the equipment under test, as defined in ETS 300 019-1-4, (Equipment Engineering (EE); Environmental conditions and environmental test for telecommunications equipment, Part 1-4: Classification of environmental conditions, Stationary use at non-weather protected locations);
- c) for equipment that does not comply to an ETS 300 019-1 [11] class, the relevant classes from IEC 721 [13] documentation for Temperature, Humidity and Vibration shall be declared.

NOTE: Reduced functionality for conditions that fall outside of the standard operational conditions are not tested in the present document. These may be stated and tested separately.

4.6.2.1 Extreme temperature

When an extreme temperature test environment is specified for a test, the test shall be performed at the standard minimum and maximum operating temperatures defined by the manufacturer's declaration for the equipment under test.

Minimum temperature:

- The test shall be performed with the environmental test equipment and methods of inducing the required environmental phenomena into the equipment, conforming to the test procedure of IEC 60068-2-1 [12], Environmental Testing, Part 2: Tests - Tests A: Cold. The equipment shall be maintained at the stabilized condition for the duration of the test sequence.

Maximum temperature:

- The test shall be performed with the environmental test equipment and methods of inducing the required environmental phenomena into the equipment, conforming to the test procedure of IEC 60068-2-2 [12] (Environmental Testing, Part 2: Tests - Tests Bd Dry heat). The equipment shall be maintained at the stabilized condition for the duration of the test sequence.

NOTE: It is recommended that the equipment is made fully operational prior to the equipment being taken to its lower operating temperature.

4.6.3 Vibration

When vibration conditions are specified for a test, the test shall be performed while the equipment is subjected to a vibration sequence as defined by the manufacturers declaration for the equipment under test. This shall use the environmental test equipment and methods of inducing the required environmental phenomena in to the equipment, conforming to the test procedure of IEC 60068-2-6 [12], Environmental Testing, Part 2: Tests - Test Fc and guidance: Vibration (Sinusoidal) or IEC 60068-2-64 [12], Test Fh: Vibration broad-band random (digital control) and guidance. Other environmental conditions shall be within the ranges specified in subclause 4.6.1, Normal test environment.

NOTE: The higher levels of vibration may induce undue physical stress in to equipment after a prolonged series of tests. The testing body should only vibrate the equipment during the RF measurement process.

4.6.4 Power supply

When extreme power supply conditions are specified for a test, the test shall be performed at the standard upper and lower limits of operating voltage defined by the manufacturer's declaration for the equipment under test.

Upper voltage limit

The equipment shall be supplied with a voltage equal to the upper limit declared by the manufacturer (as measured at the input terminals to the equipment). The tests shall be carried out at the steady state minimum and maximum temperature limits declared by the manufacturer for the equipment, to the methods described in IEC 68-2-1 [12] Test Ab/Ad: Cold and IEC 60068-2-2 [12] Test Bb/Bd: Dry Heat.

Lower voltage limit

The equipment shall be supplied with a voltage equal to the lower limit declared by the manufacturer (as measured at the input terminals to the equipment). The tests shall be carried out at the steady state minimum and maximum temperature limits declared by the manufacturer for the equipment, to the methods described in IEC 60068-2-1 [12] Test Ab/Ad: Cold and IEC 60068-2-2 [12] Test Bb/Bd: Dry Heat.

4.7 Acceptable uncertainty of measurement equipment

The maximum acceptable uncertainty of measurement equipment is specified separately for each test, where appropriate. The measurement equipment shall enable the stimulus signals in the test case to be adjusted to within the specified tolerance, and the conformance requirement to be measured with an uncertainty not exceeding the specified values. All tolerances and uncertainties are absolute values, unless otherwise stated.

For the test methods, according to the present document, the measurement uncertainty figures shall be calculated in accordance with ETR 028 [15] and shall correspond to an expansion factor (coverage factor) $k = 1,96$ or $k = 2$ (which provide confidence levels of respectively 95% and 95,45% in the case where the distributions characterising the actual measurement uncertainties are normal (Gaussian).

Subclause 4.6, Test environments:

Pressure	±5 kPa
Temperature	±2 degrees
Relative Humidity	±5 %
DC Voltage	±1,0 %
AC Voltage	±1,5 %
Vibration	10 %
Vibration frequency	0,1 Hz

The above values shall apply unless the test environment is controlled and the specification for the control of the test environment specifies the uncertainty for the parameter.

Transmitter

Subclause 6.2, Modulation accuracy:

Conformance requirement:

Frequency, GMSK	± 10 Hz ± 5 Hz for GSM 400
Phase	1,5 degree rms 5 degrees peak
EVM	$-(0,75 + 0,025\text{RMS_EVM}) - +(0,75 + 0,025\text{RMS_EVM})$ % RMS ± 4 % for individual measurement samples
Origin Offset suppression	$\pm 1,5$ dB
Frequency, 8-PSK	± 16 Hz

NOTE 1: The value of the RMS EVM specification is a function of the value of RMS_EVM being measured. The asymmetric specification results from the RMS EVM minimisation method used for parameter estimation (see GSM 05.05, Annex G). This method of measurement for RMS EVM always produces a result that is lower than the actual value of RMS EVM.

NOTE 2: The value for individual EVM samples assumes a Rayleigh distribution of measurement errors. It represents the maximum 95th percentile value test equipment should return when measuring a signal without error.

Subclause 6.3, Mean transmitted RF carrier power:

Conformance requirement:

RF power, for static power step 0	$\pm 1,0$ dB
Relative RF Power, for other power steps	$\pm 0,7$ dB

Subclause 6.4, Transmitted RF carrier power versus time:

Conformance requirement

RF power (0 dB reference)	$\pm 1,0$ dB
RF power relative to 0 dB reference	± 10 dB

Subclause 6.5.1, Spectrum due to modulation and wideband noise:

Conformance requirement

RF power (absolute limit values)	$\pm 1,0$ dB
----------------------------------	--------------

NOTE 1: This may require calibration of the power levels corresponding to the limit values.

Relative RF power:

Offset from carrier, MHz	Power difference, dB	Uncertainty of relative power, dB
$\delta f \leq 0.1$ MHz	All	$\pm 0,5$ dB
0.1 MHz $< \delta f \leq 1.8$ MHz	< 50 dB	$\pm 0,7$ dB
0.1 MHz $< \delta f \leq 1.8$ MHz	≥ 50 dB	$\pm 1,5$ dB
> 1.8 MHz	All	$\pm 2,0$ dB

Subclause 6.5.2, Switching transients spectrum:

Conformance requirement:

RF power: $\pm 1,5$ dB

Relative RF power:

Power difference < 50 dB $\pm 0,7$ dB

Power difference ≥ 50 dB $\pm 1,5$ dB

Subclause 6.6.1, Conducted spurious emissions from the transmitter antenna connector, inside the BTS transmit band:

Conformance requirement:

RF power: $\pm 1,5$ dB

Subclause 6.6.2, Conducted spurious emissions from the transmitter antenna connector, outside the BTS transmit band:

Conformance requirement:

Conformance requirement i) (in the receive band of the BSS):

RF power ± 3 dB

Conformance requirements ii), iii) and iv) (elsewhere):

RF power:

$f \leq 2$ GHz $\pm 1,5$ dB

2 GHz < $f \leq 4$ GHz $\pm 2,0$ dB

$f > 4$ GHz $\pm 4,0$ dB

Subclause 6.7, Intermodulation attenuation and

Subclause 6.8, Intra base station system intermodulation attenuation:

Test case:

Relative RF power (of injected signal); $\pm 1,5$ dB

Conformance requirement (outside RX band):

RF power; absolute limit values $\pm 1,5$ dB

RF power, relative measurements $\pm 2,0$ dB

Conformance requirement (inside RX band):

RF power; absolute limit values +4 dB - 3 dB

NOTE 2: The positive limit for uncertainty is greater than the negative limit because the measurement result can be increased (but not decreased) due to intermodulation products within the measurement apparatus.

Receiver

Where a measurement uncertainty of +5 dB -0 dB is specified for an input signal, the measured value of the input signal should be increased by an amount equal to the uncertainty with which it can be measured. This will ensure that the true value of the input signal is not below the specified nominal.

Subclause 7.1, Static layer 1 receiver functions:

Test case

RF power, lower limit +5 - 0 dB

RF power, -40 dBm nominal $\pm 2,5$ dB

RF power, -23 and -15 dBm nominal $\pm 1,5$ dB

Subclause 7.2, Erroneous frame indication performance:

Test case:

RF Power +5 - 0 dB

Subclause 7.3, Static reference sensitivity level:

Test case:

RF power $\pm 1,0$ dB

Relative RF power (adjacent timeslots) $\pm 3,0$ dB

Subclause 7.4, Multipath reference sensitivity level:

Test case:

RF power $\pm 1,5$ dB

Relative RF power $\pm 3,0$ dB

Subclause 7.5, Reference interference level:

Test case:

RF power +5 - 0 dB

Relative RF power $\pm 1,0$ dB

NOTE 3: The measurement uncertainty for a faded (multipath) input signal may depend on the time taken to average the power of the b signal from the fader. It may be possible to reduce the measurement time by measuring the power with the fader set to the same class of fade profile, but with an increased fade rate.

Subclause 7.6, Blocking characteristics:

Test case:

RF power, wanted signal $\pm 1,0$ dB

RF power, interfering signal;

$f \leq 2$ GHz $\pm 0,7$ dB

2 GHz $< f \leq 4$ GHz $\pm 1,5$ dB

$f > 4$ GHz $\pm 3,0$ dB

Subclause 7.7, Intermodulation characteristics and subclause 7.8 AM suppression:

Test case:

RF power, wanted signal $\pm 1,0$ dB

RF power, interfering signals $\pm 0,7$ dB

Subclause 7.9, Spurious emissions from the receiver antenna connector:

Conformance requirement:

RF power;

$f \leq 2$ GHz $\pm 1,5$ dB

2 GHz $< f \leq 4$ GHz $\pm 2,0$ dB

$f > 4$ GHz $\pm 4,0$ dB

Clause 8, Radiated spurious emissions:

Conformance requirement:

RF power; $\pm 6,0$ dB

Clause 9, Radio link management:

Test case:

RF power $\pm 1,0$ dB

Relative RF power $\pm 0,7$ dB

Conformance requirement:

Timing difference single measurement $\pm 1/4$ bit

average of 100 measurements $\pm 0,1$ bit

4.8 Interpretation of measurement results

The measurement value related to the corresponding limit shall be used to decide whether an equipment meets a requirement in the present document.

The measurement uncertainty for the measurement of each parameter shall be included in the test report.

The recorded value for the measurement uncertainty shall be, for each measurement, equal to or lower than the appropriate figure in subclause 4.7 of the present document.

NOTE: This procedure is recommended in ETR 028 [15].

If the measurement apparatus for a test is known to have a measurement uncertainty greater than that specified in subclause 4.7, it is still permitted to use this apparatus provided that an adjustment is made to the measured value as follows.

The adjustment is made by subtracting the modulus of the specified measurement uncertainty in subclause 4.7 from the measurement uncertainty of the apparatus. The measured value is then increased or decreased by the result of the subtraction, whichever is most unfavourable in relation to the limit.

4.9 Selection of configurations for testing

Most tests in the present document are only performed for a subset of the possible combinations of test conditions. For instance:

- not all TRXs in the configuration may be specified to be tested;
- only one RF channel may be specified to be tested;
- only one timeslot may be specified to be tested.

When a test is performed by a test laboratory, the choice of which combinations are to be tested shall be specified by the laboratory. The laboratory may consult with operators, the manufacturer or other bodies.

When a test is performed by a manufacturer, the choice of which combinations are to be tested may be specified by an operator.

4.10 BTS Configurations

The present document has been written to specify tests for the standard configurations of BTS which have been assumed in GSM requirements specifications, In particular GSM 05.01, 05.02 and 05.05. However, there are other configurations of BTS which comply with these specifications, but for which the application of these specifications is not fully defined. For some such configurations there may be alternate ways to apply the requirements of this specification to testing of the configuration, or some variation in the test method may be necessary. It may therefore be necessary for the parties to the testing to reach agreement over the method of testing in advance.

If the BSS is supplied in a number of different environmental enclosures or configurations, it may not be necessary to test RF parameters for each environmental configuration, provided that it can be demonstrated that the equipment has been tested at the worst internal environmental conditions

If a BTS is supplied with a number of different configurations of passive TX antenna combiners, there may be alternate ways to demonstrate the compliance rather than performing the measurements for each configuration. As an example, the worst case configuration of the antenna combiners for a given test shall as a minimum be used for this purpose.

Where alternative interpretations of this specification are possible for a BSS configuration under test, the interpretation which has been adopted in performing the test shall be recorded with the test results.

Where variation in the test method within the present document has been necessary to enable a BSS configuration to be tested, the variation in the test method which has been made in performing the test shall be recorded with the test results. Where possible, agreement should be reached in advance about the nature of such a variation with any party who will later receive the test results.

Possible interpretations of the present document for some common configurations are given in the following subclauses.

4.10.1 Receiver diversity

- i) For the tests in clause 7 of the present document, the specified test signals may be applied to one receiver antenna connector, with the remaining receiver antenna connectors being terminated with 50 ohms.

or

- ii) For the tests in clause 7 of the present document, the specified test signals may be simultaneously applied to each of the receiver antenna connectors.

4.10.2 Duplexers

The requirements of the present document shall be met with a duplexer fitted, if a duplexer is supplied as part of the BSS. If the duplexer is supplied as an option by the manufacturer, sufficient tests should be repeated with and without the duplexer fitted to verify that the BSS meets the requirements of the present document in both cases.

The following tests should be performed with the duplexer fitted, and without it fitted if this is an option.

- 1) Subclause 6.3, Mean transmitted RF power, for the highest static power step only, if this is measured at the antenna connector.
- 2) Subclause 6.6.2, Conducted spurious emissions from the transmitter antenna connector; outside the BTS transmit band.
- 3) Subclause 6.8, Intra base station system intermodulation attenuation.
- 4) Subclause 7.4, Multipath reference sensitivity; for the testing of essential conformance, the ARFCNs should be selected to minimize intermodulation products from the transmitters falling in receive channels.

The remaining tests may be performed with or without the duplexer fitted.

NOTE 1: When performing receiver tests with a duplexer fitted, it is important to ensure that the output from the transmitters does not affect the test apparatus. This can be achieved using a combination of attenuators, isolators and filters.

NOTE 2: When duplexers are used, intermodulation products will be generated, not only in the duplexer but also in the antenna system. The intermodulation products generated in the antenna system are not controlled by ETSI specifications, and may degrade during operation (e.g. due to moisture ingress). Therefore, to ensure continued satisfactory operation of a BSS, an operator will normally select ARFCNs to minimize intermodulation products falling on receive channels. For testing of complete conformance, an operator may specify the ARFCNs to be used.

4.10.3 Power supply options

If the BSS is supplied with a number of different power supply configurations, it may not be necessary to test RF parameters for each of the power supply options, provided that it can be demonstrated that the range of conditions over which the equipment is tested is at least as great as the range of conditions due to any of the power supply configurations.

This applies particularly if a BSS contains a DC rail which can be supplied either externally or from an internal mains power supply. In this case, the conditions of extreme power supply for the mains power supply options can be tested by testing only the external DC supply option. The range of DC input voltages for the test should be sufficient to verify the performance with any of the power supplies, over its range of operating conditions within the BTS, including variation of mains input voltage, temperature and output current.

4.10.4 Ancillary RF amplifiers

Ancillary RF amplifier: a piece of equipment, which when connected by RF coaxial cables to the BTS, has the primary function to provide amplification between the transmit and/or receive antenna connector of a BTS and an antenna without requiring any control signal to fulfil its amplifying function.

The requirements of the present document shall be met with the ancillary RF amplifier fitted. At tests according to clauses 6 and 7 for TX and RX respectively, the ancillary amplifier is connected to the BTS by a connecting network (including any cable(s), attenuator(s), etc.) with applicable loss to make sure the appropriate operating conditions of the ancillary amplifier and the BTS. The applicable connecting network loss range is declared by the manufacturer. Other characteristics and the temperature dependence of the attenuation of the connecting network are neglected. The actual attenuation value of the connecting network is chosen for each test as one of the applicable extreme values. The lowest value is used unless otherwise stated.

Sufficient tests should be repeated with the ancillary amplifier fitted and, if it is optional, without the ancillary RF amplifier to verify that the BSS meets the requirements of the present document in both cases.

When testing for essential conformance, the following tests should be repeated with the optional ancillary amplifier fitted according to the table below, where x denotes that the test is applicable:

	Subclause	TX amplifier only	RX amplifier only	TX/RX amplifiers combined (Note)
Receiver tests	7.3		x	x
	7.6		x	x
	7.7		x	x
	7.9		x	
Transmitter tests	6.3	x		x
	6.5 (6.5.1 only)	x		x
	6.6	x		x
	6.7	x		x
	6.8	x		x

NOTE: Combining can be by duplex filters or any other network. The amplifiers can either be in RX or TX branch or in both. Either one of these amplifiers could be a passive network.

For receiver tests only testing on TCH/FS is required

In test according to subclause 7.3 and 6.3 highest applicable attenuation value is applied.

4.10.5 BSS using antenna arrays

A BSS may be configured with a multiple antenna port connection for some or all of its TRXs or with an antenna array related to one cell (not one array per TRX). This section applies to a BSS which meets at least one of the following conditions:

- the transmitter output signals from one or more TRX appear at more than one antenna port; or
- there is more than one receiver antenna port for a TRX or per cell and an input signal is required at more than one port for the correct operation of the receiver (NOTE: diversity reception does not meet this requirement) thus the outputs from the transmitters as well as the inputs to the receivers are directly connected to several antennas (known as „aircombining"); or
- transmitters and receivers are connected via duplexers to more than one antenna.

If a BSS is used, in normal operation, in conjunction with an antenna system which contains filters or active elements which are necessary to meet the GSM requirements, the tests of essential conformance may be performed on a system comprising the BSS together with these elements, supplied separately for the purposes of testing. In this case, it must be demonstrated that the performance of the configuration under test is representative of the system in normal operation, and the conformance assessment is only applicable when the BSS is used with the antenna system.

For testing of essential conformance of such a BSS, the following procedure may be used.

Receiver tests

For each test, the test signals applied to the receiver antenna connectors shall be such that the sum of the powers of the signals applied equals the power of the test signal(s) specified in the test.

An example of a suitable test configuration is shown in figure 1a.

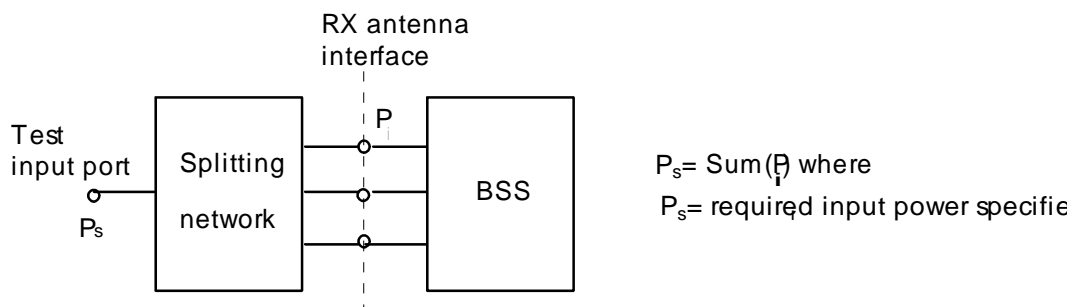

Figure 1a: Receiver test setup

For spurious emissions from the receiver antenna connector, the test may be performed separately for each receiver antenna connector.

Transmitter tests

For each test, the conformance requirement shall be met by the sum of the signals emitted by each transmitter antenna connector. This may be assessed by separately measuring the signals emitted by each antenna connector and summing the results, or by combining the signals and performing a single measurement. The characteristics (e.g. amplitude and phase) of the combining network should be such that the power of the combined signal is maximised.

An example of a suitable test configuration is shown in figure 1b.

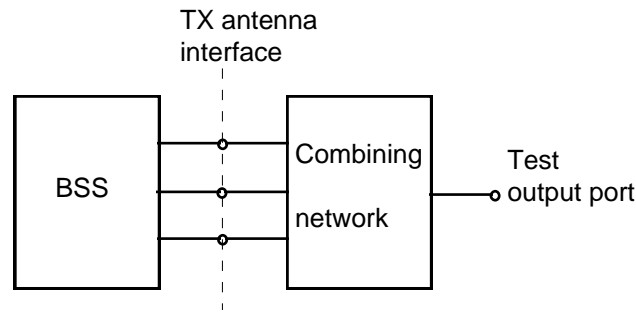

Figure 1b: Transmitter test setup

For Intermodulation attenuation, the test may be performed separately for each transmitter antenna connector.

4.10.6 BTS supporting 8-PSK modulation

If a TRX supports 8-PSK it shall, unless otherwise stated in the tests in clause 6 to 9, be tested at both GMSK and 8-PSK modulation unless it can be demonstrated that it is sufficient to test only at GMSK or 8-PSK modulation.

If a BTS is configured with both TRXs supporting 8-PSK and TRXs not supporting 8-PSK the stated number of TRXs to be tested shall apply to each type of TRX.

5 Format and interpretation of tests

Each test in the following clauses has a standard format:

X Title

All tests are applicable to all equipment within the scope of this specification, unless the title of the test is Applicability (Phase 2) or Applicability (Phase 2+), and the applicability is defined below.

X.1 Test purpose

This subclause defines the purpose of the test.

X.2 Test case

This subclause describes the steps necessary to perform the test. The general test conditions described in clause 4 also apply.

X.3 Essential conformance

The essential conformance describes the conformance requirements necessary to ensure compatibility and to verify the important aspects of the transmission quality of the system. This subclause is divided into two parts:

Test environment

This subclause describes the test environment or environments under which the test shall be performed. Where more than one test environment is specified, the extent of testing is specified for each environment.

Conformance requirement

This subclause describes the requirement which shall be met for the specified tests.

The test case describes the testing for full conformance; for most tests a subset of these tests is specified for essential conformance. Therefore, any definition of testing in the essential conformance shall take precedence over the test case.

X.4 Complete conformance

The complete conformance describes the complete set of tests which may be performed to fully characterize all aspects of one performance parameter of the BSS.

Test environment

This subclause describes the test environment or environments under which the test shall be performed. Where more than one test environment is specified, the extent of testing is specified for each environment.

Conformance requirement

This subclause describes the requirement which shall be met for the specified tests.

X.5 Requirement reference

This subclause gives the reference to the subclauses in the GSM specifications from which the test requirements have been derived. Where the Requirement reference subclause references the ETSs corresponding to both the Phase 2 and Phase 2+ versions of the same GSM specification, the Phase 2 and Phase 2+ requirements which are referenced are consistent.

6 Transmitter

All tests in this Clause shall be conducted on Base Station Systems fitted with a full complement of Transceivers for the configuration unless otherwise stated. Measurements shall be made at the BTS Tx antenna connector, unless otherwise stated.

Power levels are expressed in dBm.

6.1 Static Layer 1 functions

6.1.1 Test purpose

To verify the following static Layer 1 transmitter functions:

- 1) the RF equipment;
- 2) the multiplexing and multiple access functions;
- 3) the interleaving and the channel encoding on the transmit side.

6.1.2 Test case

The BSS shall be configured with the maximum number of TRXs, with ARFCNs which shall be distributed over the entire declared bandwidth of operation for the BSS under test. One TRX shall be configured to support the BCCH. If the manufacturer declares that slow frequency hopping is supported, this shall be enabled.

Each TRX shall transmit a normal GSM modulated signal and the BSSTE shall be connected to the transmitter antenna connector. A known bit sequence exceeding a length of a superframe (1326 TDMA-frames) shall be input before channel encoding in the BSS and a bit sequence shall be output after channel decoding in the BSSTE.

All logical channel types supported by the BSS shall be tested. The test shall be repeated for each TRX in the BSS configuration, for each logical channel supported by it.

NOTE: Some logical channels are only supported by the TRX configured to support the BCCH.

6.1.3 Essential conformance

This test need not be performed.

6.1.4 Complete conformance

Test Environment

Normal.

Conformance requirement

The output bit sequence shall be bit exact for all logical channel types.

6.1.5 Requirement reference

GSM 05.01 [3], GSM 05.02 (ETS 300 908) [4], GSM 05.03 (ETS 300 909) [5] and GSM 05.05 (ETS 300 910) [7].

6.2 Modulation accuracy

6.2.1 Test purpose

- 1) To verify the correct implementation of the pulse shaping filtering.
- 2) To verify that the phase error during the active part of the time slot does not exceed the specified limits under normal and extreme test conditions and when subjected to vibration.
- 3) To verify that the frequency error during the active part of the time slot does not exceed the specified limits under normal and extreme test conditions and when subjected to vibration.

6.2.2 Test case

All TRXs in the configuration shall be switched on transmitting full power in all time slots for at least 1 hour before starting the test.

If the Manufacturer declares that Synthesizer Slow Frequency Hopping is supported by the BSS, the BSS shall be configured with the maximum number of TRXs with ARFCNs which shall be distributed over the entire declared bandwidth of operation for the BSS under test, and including B, M and T, and three tests shall be performed. These tests may either use a test apparatus which employs the same hopping sequence as the BSS, or a fixed frequency apparatus on the radio frequency channels B, M and T. If only Baseband SFH is supported or SFH is not supported, one test shall be performed for each of the radio frequency channels B, M and T, using different TRXs to the extent possible for the configuration. As a minimum, one time slot shall be tested on each TRX specified to be tested.

GMSK modulation

The transmitted GMSK modulated signal from the TRX under test shall be extracted in the BSSTE for a pseudo-random known bit stream of encrypted bits into the TRX modulator (the BSSTE is defined in annex B.1). The pseudo-random bit stream shall be any 148 bit sub-sequence of the 511 bit pseudo-random bit stream defined in recommendation CCITT Q.153 fascicle IV.4. This pseudo-random bit stream may be generated by another pseudo-random bit stream inserted before channel encoding in the TRX and shall generate at least 200 different bursts. The phase trajectory (phase versus time) for the useful part of the time slots (147 bits in the centre of the burst - see GSM 05.04 (ETS 300 959) [6] and GSM 05.10 (EN 300 912) [9] for further information) shall be extracted with a resolution of at least 2 samples per modulating bit. The RF receiver parts of the BSSTE shall not limit the measurement.

The theoretical phase trajectory from the known pseudo-random bit stream shall be calculated in the BSSTE.

The phase difference trajectory shall be calculated as the difference between the measured and the theoretical phase trajectory. The mean frequency error across the burst shall then be calculated as the derivative of the regression line of the phase difference trajectory. The regression line shall be calculated using the Mean Square Error (MSE) method.

The phase error is then finally the difference between the phase difference trajectory and its linear regression line.

8-PSK modulation

The transmitted 8-PSK modulated signal from the TRX under test shall be extracted in the BSSTE for a pseudo-random known bit stream of encrypted bits into the TRX modulator (the BSSTE is defined in annex B.1). The pseudo-random bit stream shall be any bit sub-sequence of the 32767-bit pseudo-random bit stream defined in recommendation CCITT O.151 10/1997.

The following steps 1) to 5) shall be performed according to GSM 05.05 (ETS300 910) [22] subclause 4.6.2 and annex G.

- 1) The RMS EVM shall be measured and calculated over the useful part of the burst (excluding tail bits) for at least 200 bursts.
- 2) The origin offset suppression shall be measured and calculated.
- 3) The frequency offset shall be measured and calculated.
- 4) The peak EVM shall be measured and calculated. The peak EVM is the peak error deviation within a burst, measured at each symbol interval, averaged over at least 200 bursts. The bursts shall have a minimum distance in time of 7 idle timeslots between them. The peak EVM values are acquired during the useful part of the burst, excluding tail bits.
- 5) The 95:th percentile EVM shall be measured and calculated. The 95:th percentile EVM is the point where 95% of the individual EVM, measured at each symbol interval, is below that point. That is, only 5% of the symbols are allowed to have an EVM exceeding the 95:th-percentile point. The EVM values are acquired during the useful part of the burst, excluding tail bits, over 200 bursts.

6.2.3 Essential conformance

Test Environment

Normal: One test shall be performed on each of B, M and T.

Extreme Power supply: One test shall be performed on each of B, M and T.

NOTE: tests under extreme power supply are carried out at extreme temperature limits.

Conformance requirement

GMSK modulation

The phase error shall not exceed:

5 degrees rms

20 degrees peak

For normal and micro BTSs the mean frequency error across the burst shall not exceed:

0,05 ppm

For pico BTSs the mean frequency error across the burst shall not exceed:

0,1 ppm

8-PSK modulation

The RMS EVM values, measured after any active element and excluding the effect of passive combining equipment, shall not exceed:

Under normal conditions 7.0 %

Under extreme conditions 8.0 %

The RMS EVM values, measured after any active element and including the effect of passive combining equipment, shall not exceed:

Under normal conditions 8.0 %

Under extreme conditions 9.0 %

The origin offset suppression shall exceed:

35 dB

For normal and micro BTSs the frequency offset shall not exceed:

0,05 ppm

For pico BTSs the frequency offset shall not exceed:

0,1 ppm

The peak EVM values, excluding the effect of passive combining equipment, shall not exceed:

22 %

The 95:th percentile EVM value, excluding the effect of passive combining equipment, shall not exceed:

11 %

6.2.4 Complete conformance

Test Environment

Normal: The test shall be repeated until 3 TRXs or all TRXs (whichever is the less) have each been tested on B, M and T.

Extreme Power supply: One test shall be performed on each of B, M and T.

NOTE: tests under extreme power supply are carried out at extreme temperature limits.

Vibration : One test shall be performed on each of B, M and T.

Conformance requirement

The requirement of essential conformance shall apply.

6.2.5 Requirement reference

[GSM 05.04 (ETS 300 959) [6], clause 2; GSM 05.05 (ETS 300 910) [7], subclause 4.6; GSM 05.10 (EN 300 912) [9], subclause 5.1].

6.3 Mean transmitted RF carrier power

6.3.1 Test purpose

To verify the accuracy of the mean transmitted RF carrier power across the frequency range and at each power step.

This test is also used to determine the parameter "power level", used in subclause 6.5.1.2.

6.3.2 Test case

For a normal BTS, this measurement the power shall be measured at the input of the TX combiner or at the BSS antenna connector. For a micro-BTS, the power shall be measured at the BSS antenna connector. The Manufacturer shall declare the maximum output power of the BSS for each supported modulation at the same reference point as the measurement is made. The TX combiner shall have the maximum number of TRXs connected to it so that the measurement can be used as a reference for the measurement of transmitted carrier power versus time in subclause 6.4.

NOTE: The value of the output power measured at the antenna connector is generally more useful for cell planning, and may be required for regulatory purposes

All TRXs in the configuration shall be switched on transmitting full power in all time slots for at least 1 hour before starting the test.

The Manufacturer shall declare how many TRXs the BSS supports:

1 TRX: The TRX shall be tested at B, M and T;

2 TRX: The TRXs shall be each be tested at B, M and T;

3 TRX or more: Three TRXs shall each be tested at B, M and T.

If the Manufacturer declares that Synthesizer Slow Frequency Hopping is supported by the BSS, the BSS shall be configured with the number of TRXs and frequency allocation defined above and SFH enabled.

The BSS under test shall be set to transmit at least 3 adjacent time slots in a TDMA-frame at the same power level. The power level shall then be measured on a time slot basis over the useful part of one of the active time slots and the average of the logarithmic value taken over at least 200 time slots. Only active bursts shall be included in the averaging process. Whether SFH is supported or not, the measurement shall be carried out on all of the 3 frequencies in turn.

For the definition of the useful part of the time slot see figure 2, and for further details GSM 05.04 (ETS 300 959) [6] and GSM 05.10 (EN 300 912) [9]. For timing on a per time slot basis each time slot may contain 156.25 modulating bits, or 2 time slots may contain 157 and 6 time slots 156 modulating bits according to GSM 05.10 (EN 300 912) [9].

The power shall be measured at each nominal power level as specified. As a minimum, one time slot shall be tested on each TRX. Any TRX which is a dedicated BCCH shall only be tested at highest static power step.

6.3.3 Essential conformance

Test Environment

Normal: Each TRX specified in the test case shall be tested.

Extreme power supply: One TRX shall be tested, on one ARFCN, for highest static power step only.

NOTE: tests under extreme power supply are carried out at extreme temperature limits.

Conformance requirement

The BSS shall support at least N_{max} steps of Static Power Control for each supported modulation with respect to the declared output power. For the modulation with the highest output power, N_{max} shall be at least 6.

The static power step N has the range from the highest static power level to N_{max} inclusive, where.

The Highest Static Power Level corresponds to the maximum output power declared by the manufacturer.

The power measured when the TRX is set to Highest Static Power Control Level shall have a tolerance of ± 2 dB under normal conditions and $\pm 2,5$ dB under extreme conditions, relative to the maximum power declared by the manufacturer for the modulation under test. In this test, this measured power is termed the maximum BTS output power. Static power control shall allow the RF output power to be reduced from the maximum BTS output power for the modulation with the highest output power capability in at least 6 steps of nominally 2 dB with a tolerance of ± 1 dB for each modulation referenced to the previous level of the same modulation. In addition, the actual absolute output power for each supported modulation at each static RF power step (N), with the exception below for the highest RF power level for 8-PSK, shall be 2^*N dB below the maximum BTS output power for the modulation with the highest output power capability with a tolerance of ± 3 dB under normal conditions and ± 4 dB under extreme conditions.

In addition to the Static Power Control levels the BSS may utilize up to M steps of dynamic Downlink Power Control. M can have an upper limit of 0 to 15.

Dynamic Downlink power control shall allow the RF output power to be reduced in M steps with a step size of 2 dB with a tolerance of $\pm 1,5$ dB referenced to the previous level.

Each dynamic Downlink Power Control level shall have a tolerance of ± 3 dB under normal conditions and ± 4 dB under extreme conditions relative to 2^*Y dB below the maximum BTS output power for the modulation with the highest output power capability, where Y is the sum of the number of static and dynamic steps below Highest Static Power Control Level for the modulation with the highest output power capability.

For BTS supporting 8-PSK, the output power for both GMSK and 8-PSK shall be nominally the same for any supported static and dynamic power control level. An exception is allowed for the maximum output power of 8-PSK, which may be lower than the GMSK output power for the same static or dynamic power control level, i.e. the nominal size of the first step down from maximum power level for 8-PSK may be in the range 0 to 2 dB. The output power of 8-PSK for the second highest static or dynamic power control level shall be the same as the GMSK power for the same static or

dynamic power control level within a tolerance of ± 1 dB The number of static RF power steps and the total number of power control steps may be different for GMSK and 8-PSK.

6.3.4 Complete conformance

The requirement of essential conformance shall apply.

6.3.5 Requirement reference

GSM 05.05 (ETS 300 910) [7] subclause 4.1.2.

6.4 Transmitted RF carrier power versus time

6.4.1 Test purpose

To verify:

- 1) the time during which the transmitted power envelope should be stable (the useful part of the time slot);
- 2) the stability limits;
- 3) the maximum output power when nominally off between time slots.

It is not the purpose of this test to measure the detail of the power ramps; this is measured as adjacent channel power in subclause 6.5.

6.4.2 Test case

The Manufacturer shall declare how many TRXs the BSS supports, and declare any TRXs which are a dedicated BCCH carrier:

- | | |
|----------------|---|
| 1 TRX: | The BSS shall not be tested. |
| 2 TRX: | One TRX shall be configured to support the BCCH and the other shall be tested. Tests shall be performed on B, M and T, and both TRXs shall be tested on at least one frequency. |
| 3 TRX: | One TRX shall be configured to support the BCCH and the other two shall be tested at B, T and B, M. Tests shall be performed on B, M and T and both TRXs shall be tested on at least one frequency. |
| 4 TRX or more: | One TRX shall be configured to support the BCCH and three TRXs tested, one on B, one on M and one on T. |

If the Manufacturer declares that Synthesizer Slow Frequency Hopping is supported by the BSS, the BSS shall be configured with the number of TRXs activated and frequency allocation defined above and SFH enabled. The TRX configured to support the BCCH shall not be tested.

If the TRX under test supports 8-PSK modulation, the test shall be performed at both GMSK and 8-PSK modulation.

A single time slot in a TDMA-frame shall be activated in all TRXs to be tested, all other time slots in the TDMA-frame shall be at Pidle.

Power measurements are made with a detector bandwidth of at least 300 kHz at the BTS antenna connector, at each frequency tested. Timing is related to T0 which is the transition time from symbol 13 to symbol 14 of the midamble training sequence for each time slot. For timing on a per time slot basis each time slot may contain 156.25 modulating symbols, or 2 time slots may contain 157 and 6 time slots 156 modulating symbols according to GSM 05.10 (EN 300 912) [9]. Measurements shall be made at Pmax and Pmin. The time slots measured shall be displayed or stored for at least 100 complete cycles of the time slot power sequence for each measurement.

Pmax = Power measured in subclause 6.3 (Highest Static Power Control Level).

Pmin = the lowest static level measured in subclause 6.3.

Pidle $P_{\max} - 30 \text{ dB}$, or $P_{\min} - 30 \text{ dB}$.

As a minimum, one time slot shall be tested on each TRX under test which is not a dedicated BCCH.

6.4.3 Essential conformance

Test Environment

Normal

Conformance requirement

The output power of each time slot tested relative to time shall conform with that illustrated in figure 2 and 2a. The residual output power, if a time slot is not activated, shall be maintained at, or below, the level of -30 dBc (300 kHz measurement bandwidth).

6.4.4 Complete conformance

The requirement of essential conformance shall apply.

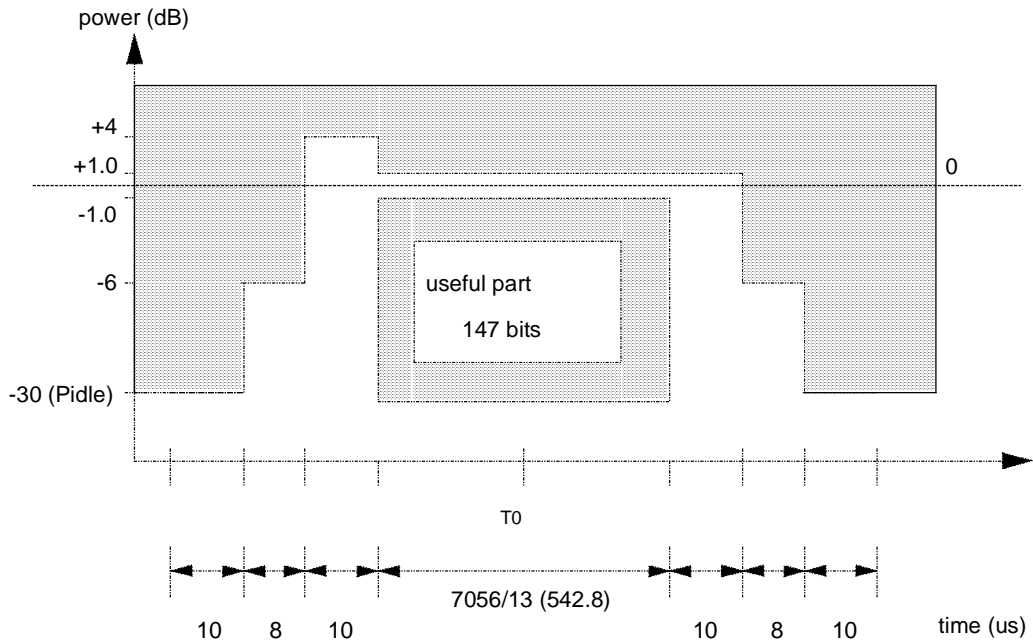

147 bits = 542.8 us = 7056/13 us

1 timeslot = 576.9 us = 156.25 bits

Power/time mask for GSM 400, GSM 900, DCS 1800, GSM 850 and MXM 850

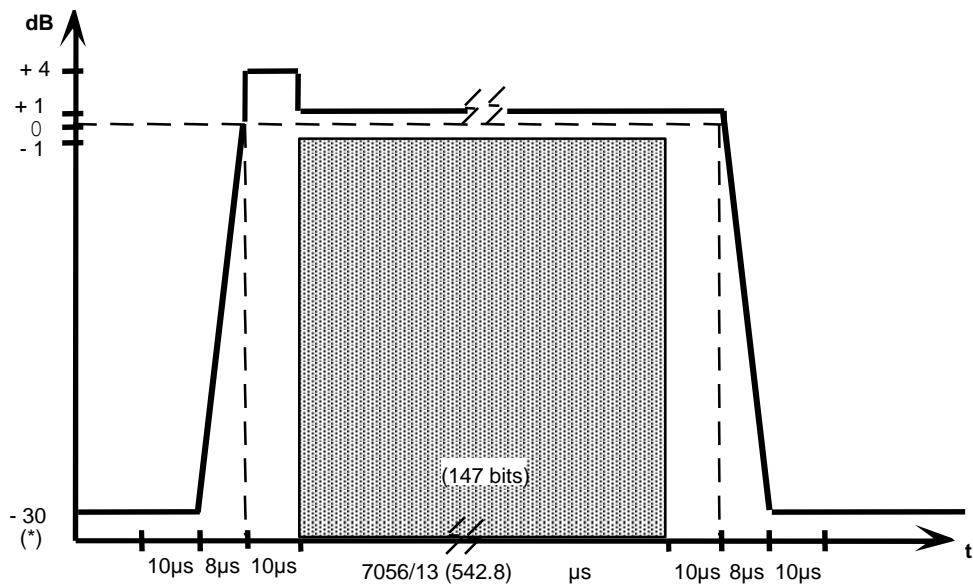

Dashed Lines indicate reference points only

Power/time mask for PCS 1900 and MXM 1900

NOTE: The 0 dB reference is equal to the power Pmax or Pmin.

Figure 2: Power/time mask for power ramping of normal bursts at GMSK modulation

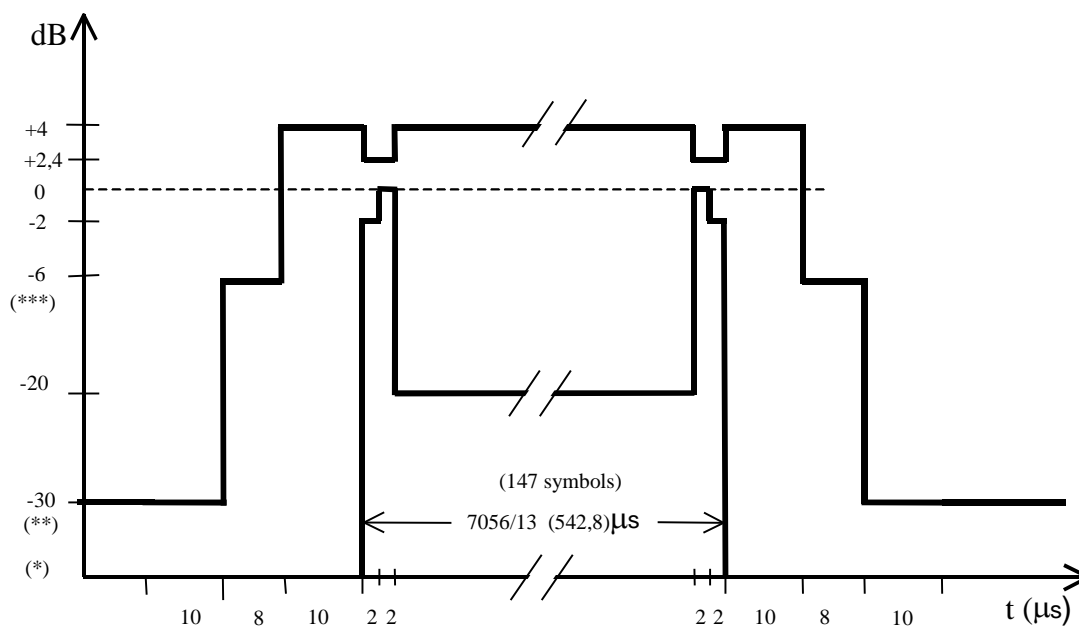

NOTE: The 0 dB reference is equal to the power Pmax or Pmin.

Figure 2a: Power/time mask for power ramping of normal bursts at 8-PSK modulation

6.4.5 Requirement reference

GSM 05.05 (EN 300 910) [22] subclause 4.5.1.

6.5 Adjacent channel power

The modulation, wideband noise and power level switching spectra can produce significant interference in the relevant TX and adjacent bands. The requirements for adjacent channel emissions are tested in two separate tests which intend to measure different sources of emission:

- 1) continuous modulation spectrum and wideband noise;
- 2) switching transients spectrum.

NOTE: Both requirements must be met, irrespective of the source of the emission at any particular frequency.

6.5.1 Spectrum due to modulation and wideband noise

6.5.1.1 Test purpose

To verify that the output RF spectrum due to modulation and wideband noise does not exceed the specified levels for an individual transceiver.

6.5.1.2 Test case

The system under test shall be tested with one TRX active or with the BTS equipped with only one TRX., at three frequencies (B, M and T).

- a) All time slots shall be set up to transmit full power GMSK modulated with a pseudo-random bit sequence of encrypted bits apart from time slot 0 which shall be set up to transmit at full power but may be modulated with normal BCCH data. The pseudo-random bit sequence may be generated by another pseudo-random bit sequence inserted before channel encoding in the BSS.
- b) The power level (as used in table 5) shall be measured using the method of subclause 6.3 for each power step to be tested.
- c) Using a filter and video bandwidth of 30 kHz the power shall be measured at the antenna connector on the carrier frequency. The measurement shall be gated over 50 - 90 % of the useful part of the time slot excluding midamble, and the measured value over this part of the burst shall be averaged. The averaging shall be over at least 200 time slots and only the active burst shall be included in the averaging process. The test is performed on one timeslot and not on timeslot 0.
- d) Step c) shall be repeated with the following offsets above and below the carrier frequency:
 - 100, 200, 250, 400 kHz; and
 - 600 to 1 800 kHz in steps of 200 kHz.
- e) With all time slots at the same power level, step c) and d) shall be repeated for all static power levels specified for the equipment (subclause 6.3).
- f) With a filter and video bandwidth of 100 kHz and all time slots active, the power shall be measured at the antenna connector for frequency offsets beyond 1800 kHz up to 2 MHz outside either side of the relevant TX band. This test shall be made in a frequency scan mode, with a minimum sweep time of 75 ms and averaged over 200 sweeps.
- g) With all time slots at the same power level, step f) shall be repeated for all static power levels specified for the equipment (subclause 6.3).
- h) If the TRX supports 8-PSK modulation, step a) to g) shall be repeated with all time slots set up to transmit 8-PSK modulation apart from timeslot 0 which may be modulated with normal BCCH data.

6.5.1.3 Essential Conformance

Test Environment

Normal

Normal BTS Conformance requirement

The test shall be performed for one TRX.

For each static power step, the power measured in steps d) to g) of the test cases shall not exceed the limits shown in table 5 for the power level measured in step b), except where one or more of the following exceptions and minimum measurement levels applies:

- 1) For a GSM 400, GSM900, GSM 850 or MXM 850 BTS, if the limit according to table 5 is below -65 dBm, a value of -65 dBm shall be used instead.
- 2) For a DCS 1800, PCS 1900 or MXM 1900 BTS, if the limit according to table 5 is below -57 dBm, a value of -57 dBm shall be used instead.
- 3) In the combined range 600 kHz to 6 MHz above and below the carrier frequency, in up to three bands of 200 kHz width centred on a frequency which is an integer multiple of 200 kHz, exceptions at up to -36 dBm are allowed.
- 4) Above 6 MHz offset from the carrier frequency, in up to 12 bands of 200 kHz width centred on a frequency which is an integer multiple of 200 kHz, exceptions at up to -36 dBm are allowed.

Table 5: Continuous modulation spectrum - maximum limits for BTS

Power level (dBm)	Maximum relative level (dB) at specified carrier offsets (kHz), using specified measurement (filter) bandwidths (kHz):							
	100	200	250	400	600 to < 1 200	1 200 to < 1 800	1 800 to < 6 000	>6000
as measured in step b)	Measurement (filter) bandwidth; 30 kHz						Measurement (filter) bandwidth; 100 kHz	
≥ 43	+0,5	-30	-33	-60*	-70	-73	-75	-80
41	+0,5	-30	-33	-60*	-68	-71	-73	-80
39	+0,5	-30	-33	-60*	-66	-69	-71	-80
37	+0,5	-30	-33	-60*	-64	-67	-69	-80
35	+0,5	-30	-33	-60*	-62	-65	-67	-80
≤ 33	+0,5	-30	-33	-60*	-60	-63	-65	-80

* For equipment supporting 8-PSK, the requirement at 8-PSK modulation is -56 dB.

The limit values in table 5, at the listed offsets from carrier frequency (kHz), are the ratio of the measured power to the measured power in step c) for the same static power step.

Table 5 provides requirements at discrete power levels. For powers between those specified, linear interpolation should be applied.

Micro and Pico-BTS Conformance requirement

The test shall be performed for one TRX.

For each static power step, the power measures in steps d) and e) of the test case shall not exceed the limits shown in table 5 for the power level measured in step b), except where one or more of the micro or pico-BTS exceptions and minimum measurement levels applies.

For each static power step, the ratio of the power measured in steps f) and g) of the test case to the power measured in step c) for the same static power step shall not exceed the limits specified in table 5a for GSM900, GSM 850 and MXM 850 and table 5b for DCS1800, PCS 1900 and MXM 1900 systems, except where one or more of the micro or pico-BTS exceptions and minimum measurement levels applies.

Table 5a: Continuous modulation spectrum - maximum limits for GSM900, GSM 850 and MXM 850 Micro and Pico-BTS

Power Class	Maximum relative level (dB) at specified carrier offsets (kHz), using specified measurement (filter) bandwidths (kHz):	
	1 800 to < 6 000	> 6 000
	Measurement (filter) bandwidth; 100kHz	
M1 to M3	-70	-70
P1	-70	-80

Table 5b: Continuous modulation spectrum - maximum limits for DCS1800, PCS 1900 and MXM 1900 Micro and Pico-BTS

Power Class	Maximum relative level (dB) at specified carrier offsets (kHz), using specified measurement (filter) bandwidths (kHz):	
	1 800 to < 6 000	> 6 000
	Measurement (filter) bandwidth; 100kHz	
M1 to M3	-76	-76
DCS 1800 P1	-76	-80
PCS 1900 and MXM 1900 P1	-76	-76

The following exceptions and minimum measurement levels shall apply for the micro and pico-BTS.

- 1) In the combined range 600 kHz to 6 MHz above and below the carrier frequency, in up to three bands of 200 kHz width centred on a frequency which is an integer multiple of 200 kHz, exceptions at up to -36 dBm are allowed.
- 2) Above 6 MHz offset from the carrier frequency, in up to 12 bands of 200 kHz width centred on a frequency which is an integer multiple of 200 kHz, exceptions at up to -36 dBm are allowed.
- 3) If the limit as specified above is below the values in table 6, then the values in table 6 shall be used instead.

Table 6: Continuous modulation spectrum - minimum levels for micro and pico-BTS

Power Class	Maximum spectrum due to modulation and noise in 100 kHz	
	GSM900, GSM 850 and MXM 850 (dBm)	DCS1800, PCS 1900 and MXM 1900 (dBm)
M1	-59	-57
M2	-64	-62
M3	-69	-67
P1	-68	-65

6.5.1.4 Complete conformance

Test Environment:

Normal.

Conformance requirement

The test shall be repeated until each TRX in the configuration has been tested. The essential conformance requirement shall be met for each TRX.

6.5.1.5 Requirement reference

GSM 05.05 (EN 300 910) [22] subclause 4.2.1.

6.5.2 Switching transients spectrum

6.5.2.1 Test purpose

To verify that the output RF spectrum due to switching transients does not exceed the specified limits.

6.5.2.2 Test case

The Manufacturer shall declare how many TRXs the BSS supports:

- 1 TRX: The TRX shall be tested at B, M and T.
- 2 TRX: One shall be configured to support the BCCH and the second TRX shall be activated and tested at B, M and T.
- 3 TRX: One shall be configured to support the BCCH and the other two shall be activated and tested. Tests shall be performed on B, M and T and both TRXs shall be tested on at least one frequency.
- 4 TRX or more: One shall be configured to support the BCCH and three TRXs shall be tested, one on B, one on M and one on T.

If the TRX supporting the BCCH is physically different from the remaining TRX(s), it shall also be tested on B, M and T.

- a) All active time slots shall be GMSK or 8-PSK modulated with a pseudo-random bit sequence apart from time slot 0 of the TRX supporting the BCCH which may be modulated with normal data. The power shall be measured at the offsets listed below from one of the carrier frequencies in the configuration with the test equipment parameters below. The reference power for relative measurements is the power measured in a bandwidth of at least 300 kHz for the TRX under test for the time slot in this test with the highest power.

Resolution bandwidth: 30 kHz

Video bandwidth: 100 kHz

Zero frequency scan

Peak hold enabled

The following offsets from the carrier frequency shall be used:

400, 600, 1200, and 1800 kHz.

- b) All timeslots of the TRX or TRXs under test shall be activated at the highest level of static power control and the power measured as described in step a). If synthesizer SFH is supported, the test shall be repeated for the TRX or TRXs which are activated and which do not support the BCCH, with them hopping between B, M and T.
- c) All timeslots of the TRX or TRXs under test shall be activated at the lowest level of static power control and the power measured as described in step a). If synthesizer SFH is supported, the test shall be repeated for the TRX or TRXs which are activated and which do not support the BCCH, with them hopping between B, M and T.
- d) Any active TRX which does not support the BCCH shall be configured with alternate timeslots active at the highest level of static power control and the remaining timeslots idle as illustrated in figure 4 and the power measured as described in step a).
- e) Any active TRX which does not support the BCCH shall be configured with alternate timeslots active at the lowest level of static power control and the remaining timeslots idle as illustrated in figure 4 and the power measured as described in step a).
- f) If the BSS supports dynamic downlink power control, any active TRX which does not support the BCCH shall be configured with transitions between timeslots active at the highest level of static power control and timeslots active at the lowest available level of dynamic power control and idle timeslots, as illustrated in figure 3 and the power measured as described in step a).

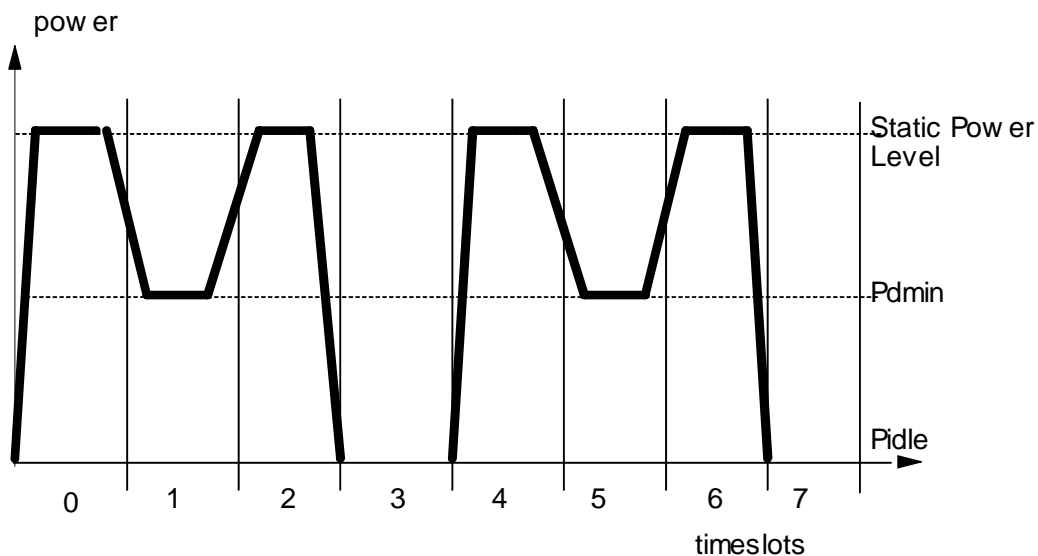

NOTE: Padmin = The lowest dynamic power step measured in subclause 6.3.

Figure 3: Power/time slot configuration (RF power control)

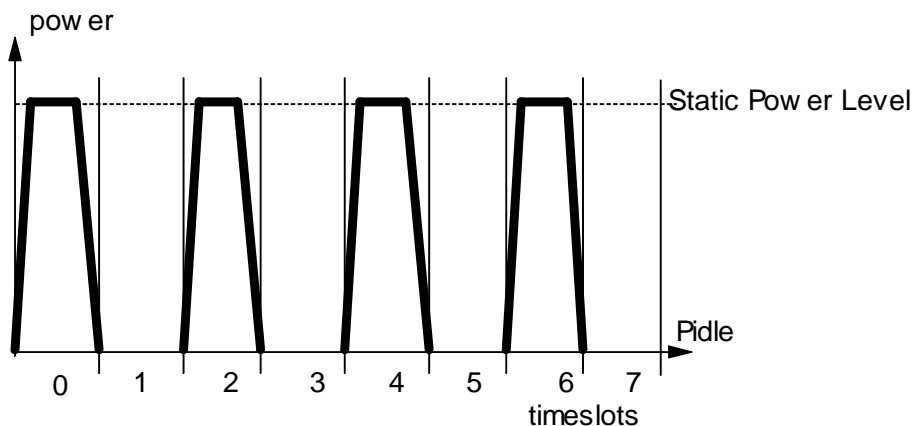

Figure 4: Power/time slot configuration (no RF power control)

6.5.2.3 Essential conformance

Test environment:

Normal.

Conformance requirement

The power measured shall not exceed the limits shown in table 7, or -36 dBm, whichever value is highest.

6.5.2.4 Complete conformance

Test environment:

Normal.

Conformance requirement

The test shall be repeated until all the TRXs specified to be tested have each been tested on the B, M and T.

The power measured shall not exceed the limits shown in table 7, or -36 dBm, whichever value is highest.

Table 7: Switching transients spectrum - maximum limits

Offset (kHz):	Power (dBc): GSM 400, GSM900, GSM 850 and MXM 850 (GMSK)	Power (dBc): GSM 400, GSM900, GSM 850 and MXM 850 (8-PSK)	Power (dBc) DCS1800, PCS 1900 and MXM 1900 (GMSK)	Power (dBc) DCS1800, PCS 1900 and MXM 1900 (8-PSK)
400	-57	-52	-50	-50
600	-67	-62	-58	-58
1200	-74	-74	-66	-66
1800	-74	-74	-66	-66

6.5.2.5 Requirement reference

GSM 05.05 (EN 300 910) [22] subclause 4.2.2.

6.6 Spurious emissions from the transmitter antenna connector

The test conditions for conducted emissions are defined separately for the BSS relevant transmit band, and elsewhere.

6.6.1 Conducted spurious emissions from the transmitter antenna connector, inside the BTS transmit band

6.6.1.1 Test Purpose

This test measures spurious emissions from the BSS transmitter antenna connector inside the BSS relevant transmit band, while one transmitter is in operation.

6.6.1.2 Test Case

The BTS shall be configured with one TRX active at its maximum output power on all time slots. The test shall be performed at RF channels B, M and T. Slow frequency hopping shall be disabled.

NOTE: It may be necessary to take steps to ensure that emissions from other transmitters which are not active do not influence the results. This may be achieved by, for example, equipping the BTS with only one TRX or by muting the outputs of the transmitters to a greater degree than otherwise required in GSM 05.05 (ETS 300 577 [7] or ETS 300 910 [22]).

The transmitter antenna connector shall be connected to a spectrum analyser or selective voltmeter with the same characteristic impedance. Peak hold shall be enabled. The power shall be measured.

For frequencies with an offset of $1.8 \text{ MHz} \leq f < 6 \text{ MHz}$ from the carrier frequency, and which fall within the relevant TX band:

- The detecting device shall be configured with a resolution bandwidth of 30 kHz and a video bandwidth of approximately three times this value.

For frequencies with an offset of $\geq 6 \text{ MHz}$ from the carrier frequency, and which fall within the relevant TX band:

- The detecting device shall be configured with a resolution bandwidth of 100 kHz and a video bandwidth of approximately three times this value.

6.6.1.3 Essential conformance

Test Environment

Normal:

Conformance requirement

The maximum power measured shall not exceed -36 dBm.

6.6.1.4 Complete conformance

The requirement of essential conformance shall apply.

6.6.1.5 Requirement Reference

GSM 05.05 (ETS 300 577) [7] subclause 4.3, or GSM 05.05 (ETS 300 910) [22] subclause 4.3.

6.6.2 Conducted spurious emissions from the transmitter antenna connector, outside the BTS transmit band

6.6.2.1 Applicability (Phase 2)

This test is applicable to equipment meeting the requirements of ETS 300 577 [7] subclauses 4.3 and 4.7.2.

6.6.2.1.1 Test Purpose

This test measures spurious emissions from the BSS transmitter antenna connector outside the BSS relevant transmit band, while the transmitters are in operation. It also tests the intra-BTS intermodulation requirements outside the BTS transmit and receive bands.

6.6.2.1.2 Test Case

- a) The BSS shall be configured with all transmitters active at their maximum output power on all time slots. If a TRX is designated as being a dedicated BCCH, it shall be allocated to RF channel M. All remaining TRXs shall be allocated in the following order; first to RF channel B, then to T, then distributed as evenly as possible throughout the BSS transmit operating band. Slow frequency hopping shall be disabled.
- b) The transmitter antenna connector shall be connected to a spectrum analyser or selective volt meter with the same characteristic impedance.

The detecting device shall be configured with a resolution and video bandwidth of 100 kHz. The minimum sweep time shall be at least 75 ms and the response shall be averaged over 200 sweeps.

The power shall be measured over the BSS receive operating band.

- c) Step b) shall be repeated for the following frequency band:
 - for a GSM 900 BSS, the band 1 805 MHz to 1 880 MHz.
 - for a DCS 1800 BSS, the band 925 MHz to 960 MHz.
- d) If the manufacturer declares that the BSS is suitable for the co-siting of GSM900 and DCS 1800 BSSs the following test shall be performed:

Step b) shall be repeated for the following frequency band:

 - for a GSM900 BSS, the band 1710 MHz to 1785 MHz.
 - for a DCS 1800 BSS, the band 880 MHz to 915 MHz.
- e) The BSS shall be configured as in step a) except that each TRX which is not a dedicated BCCH shall transmit on full power on alternate time slots. The active timeslots should be the same for all TRXs. Either odd or even timeslots may be tested. If slow frequency hopping is supported, each TRX which is not a dedicated BCCH shall hop over the full range of frequencies defined in step a).

The detecting device shall be configured as defined in table 8a. Peak hold shall be enabled, and the video bandwidth shall be approximately three times the resolution bandwidth. If this video bandwidth is not available on the detecting device, it shall be the maximum available, and at least 1 MHz.

The power shall be measured over those parts of the frequency range 100 kHz to 12.75 GHz which are outside the BTS relevant transmit band.

Table 8a: Spurious Emissions Measurements outside the transmit band

Frequency Band	Frequency offset	Resolution Bandwidth
100 kHz - 50 MHz		10 kHz
50 MHz - 500 MHz		100 kHz
500 MHz - 12,75 GHz and outside the relevant transmit band	(offset from the edge of the relevant transmit band)	
	≥ 2 MHz	30 kHz
	≥ 5 MHz	100 kHz
	≥ 10 MHz	300 kHz
	≥ 20 MHz	1 MHz
	≥ 30 MHz	3 MHz

6.6.2.1.3 Essential conformance

Test Environment

Normal:

Conformance requirement

- i) The maximum power measured at step c) shall not exceed -47 dBm for a GSM 900 BTS or -57 dBm for a DCS 1800 BTS
- ii) The maximum power measured at step e) shall not exceed:
 - -36 dBm for frequencies up to 1 GHz;
 - -30 dBm for frequencies above 1 GHz.

6.6.2.1.4 Complete conformance

Test Environment

Normal:

Conformance requirement

- 1) The maximum power measured at step b) shall not exceed the requirements in table 8b:

Table 8b: Requirements for transmitter spurious emissions in receiver bands

	GSM BSS receive band (dBm)	DCS 1800 BSS receive band (dBm)
Normal BTS	-98	-98
Micro BTS M1	-91	-96
Micro BTS M2	-86	-91
Micro BTS M3	-81	-86

- 2) The maximum power measured at step c) shall not exceed -47 dBm for a GSM 900 BSS or -57 dBm for a DCS 1800 BSS;
- 3) The maximum power measured at step e) shall not exceed:
 - -36 dBm for frequencies up to 1 GHz;
 - -30 dBm for frequencies above 1 GHz.
- 4) If the manufacturer declares that the BSS is suitable for co-siting of GSM 900 and DCS 1800 BSSs, the power measured in step d) shall not exceed the requirements in table 9.

6.6.2.1.5 Requirement Reference

GSM 05.05 (ETS 300 577) [7] subclauses 4.3 and 4.7.2

6.6.2.2 Applicability (Phase 2+)

This test is applicable to equipment meeting the requirements of EN 300 910 [22] subclauses 4.3 and 4.7.2.

6.6.2.2.1 Test Purpose

This test measures spurious emissions from the BSS transmitter antenna connector outside the BSS relevant transmit band, while the transmitters are in operation. It also tests the intra-BTS intermodulation requirements for GSM 400, GSM 850, GSM 900, DCS 1800 and PCS 1900 outside the BTS transmit and receive bands.

6.6.2.2.2 Test Case

- a) The BSS shall be configured with all transmitters active at their maximum output power on all time slots. If a TRX is designated as being a dedicated BCCH, it shall be allocated to RF channel M. All remaining TRXs shall be allocated in the following order; first to RF channel B, then to T, then distributed as evenly as possible throughout the BSS operating transmit band. Slow frequency hopping shall be disabled.
- b) The transmitter antenna connector shall be connected to a spectrum analyser or selective volt meter with the same characteristic impedance.

The detecting device shall be configured with a resolution and video bandwidth of 100 kHz. The minimum sweep time shall be at least 75 ms and the response shall be averaged over 200 sweeps.

The power shall be measured over the BSS operating receive band.

- c) Step b) shall be repeated for the following frequency band:
 - for a GSM 900 or GSM 400 BSS, the band 1 805 MHz to 1 880 MHz.
 - for a DCS 1800 or GSM 400 BSS, the band 921 MHz to 960 MHz.
 - for a GSM 850 or MXM 850 BSS, the band 1 930 MHz to 1 990 MHz.
 - for a PCS 1900 or MXM 1900 BSS, the band 869 MHz to 894 MHz.
- d) If the manufacturer declares that the BSS is suitable for the co-siting of GSM 400, GSM 900 and DCS 1800 BSSs or co-siting of MXM 850 and MXM 1900 BSS or co-siting of GSM 850 and PCS 1900 BSS the following test shall be performed:

Step b) shall be repeated for the following frequency band:

- for a GSM 900 or GSM 400 BSS, the band 1 710 MHz to 1 785 MHz.
 - for a DCS 1800 or GSM 400 BSS, the band 876 MHz to 915 MHz.
 - for a GSM 900 or DCS 1800 BSS suitable for co-siting with a GSM 400 BSS, the bands 450,4 – 457,6 MHz and 478,8 – 486,0 MHz.
 - for a GSM 850 or MXM 850 BSS, the band 1 850 MHz to 1 910 MHz.
 - for a PCS 1900 or MXM 1900 BSS, the band 824 MHz to 849 MHz.
- e) The BSS shall be configured as in step a) except that each TRX which is not a dedicated BCCH shall transmit on full power on alternate time slots. The active timeslots should be the same for all TRXs. Either odd or even timeslots may be tested. If slow frequency hopping is supported, each TRX which is not a dedicated BCCH shall hop over the full range of frequencies defined in step a).

The detecting device shall be configured as defined in table 9a. Peak hold shall be enabled, and the video bandwidth shall be approximately three times the resolution bandwidth. If this video bandwidth is not available on the detecting device, it shall be the maximum available, and at least 1 MHz.

The power shall be measured over those parts of the frequency range 100 kHz to 12.75 GHz which are outside the BTS relevant transmit band.

- f) If the manufacturer declares that the BSS protects co-coverage GSM 400 systems the following test shall be performed:

Step b) shall be repeated for the following frequency band:

- for a GSM 900 or DCS 1800 BSS, the bands 460,4 – 467,6 MHz and 488,8 – 496,0 MHz.

Table 9a: Spurious Emissions Measurements outside the transmit band

Frequency Band	Frequency offset	Resolution Bandwidth
100 kHz - 50 MHz		10 kHz
50 MHz - 500 MHz and outside the relevant transmit band	(offset from the edge of the relevant transmit band)	
	≥ 2 MHz	30 kHz
	≥ 5 MHz	100 kHz
500 MHz - 12,75 GHz and outside the relevant transmit band	(offset from the edge of the relevant transmit band)	
	≥ 2 MHz	30 kHz
	≥ 5 MHz	100 kHz
	≥ 10 MHz	300 kHz
	≥ 20 MHz	1 MHz
	≥ 30 MHz	3 MHz

6.6.2.2.3 Essential conformance

Test Environment

Normal:

Conformance requirement

- i) The maximum power measured at step c) shall not exceed:
 - 47 dBm for a GSM 900, GSM 850 or MXM 850 BTS;
 - 57 dBm for a DCS 1800, PCS 1900 or MXM 1900 BTS;
 - 47 dBm for a GSM 400 BTS in the band 1 805 MHz to 1 880 MHz;
 - 57 dBm for a GSM 400 BTS in the band 925 MHz to 960 MHz.
- ii) The maximum power measured at step e) or f) shall not exceed:
 - 36 dBm for frequencies up to 1 GHz;
 - 30 dBm for frequencies above 1 GHz.

6.6.2.2.4 Complete conformance

Test Environment

Normal:

Conformance requirement

- 1) The maximum power measured at step b) shall not exceed the requirements in table 9b:

Table 9b: Requirements for transmitter spurious emissions in receiver bands

	GSM 400, GSM 900, GSM 850 and MXM 850 BSS receive band (dBm)	DCS 1800, PCS 1900 and MXM 1900 BSS receive band (dBm)
Normal BTS	-98	-98
Micro BTS M1	-91	-96
Micro BTS M2	-86	-91
Micro BTS M3	-81	-86
Pico-BTS P1	-70	-80
R-GSM900 BTS	-89	
NOTE: Micro and pico-BTS is not defined for GSM400.		

- 2) The maximum power measured at step c) shall not exceed:

- 47 dBm for a GSM 900, GSM 850 or MXM 850 BSS;
- 57 dBm for a DCS 1800, PCS 1900 or MXM 1900 BSS;
- 47 dBm for a GSM 400 BTS in the band 1 805 MHz to 1 880 MHz;
- 57 dBm for a GSM 400 BTS in the band 925 MHz to 960 MHz.

3) The maximum power measured at step e) shall not exceed:

- 36 dBm for frequencies up to 1 GHz
- 30 dBm for frequencies above 1 GHz

4) If the manufacturer declares that the BSS is suitable for co-siting of GSM 400, GSM 900 and DCS 1800 BSSs, the power measured in step d) shall not exceed the requirements in table 9b.

5) If the manufacturer declares that the BSS is suitable for co-siting of MXM 850 and MXM 1900 BSSs or co-siting of GSM 850 and PCS 1900 BSSs, the power measured in step d) shall not exceed the requirements in table 9b.

6) If the manufacturer declares that the BSS protects co-coverage GSM 400 systems the maximum power measured at step f) shall not exceed:

- 57 dBm for a GSM 900, or DCS 1800 BSS

6.6.2.2.5 Requirement Reference

GSM 05.05 (EN 300 910) [22] subclauses 4.3, 4.7.2

6.6.2.3 Applicability (Phase 2+ Release 1999 GSM 400, GSM 900 and DCS 1800)

If this test is applicable subclause 6.6.2.2 is also applicable.

This test is applicable to GSM 400, GSM 900 and DCS 1800 equipment supporting any of the release 1999 features GSM 400 or 8-PSK modulation with the following exceptions:

- If a BTS is built to a specification for Release 98 or earlier and is upgraded to Release 99 or later, by exchange to or addition of transceivers supporting 8-PSK, any transmitters not supporting 8-PSK shall be excluded in step a in subclause 6.6.2.3.2.

6.6.2.3.1 Test Purpose

This test measures spurious emissions from the BSS transmitter antenna connector in the UTRA UE and BS receive bands, while the transmitters are in operation.

6.6.2.3.2 Test Case

- a) The BSS shall be configured with all transmitters, not excluded according to subclause 6.6.2.3, active at their maximum output power on all time slots. If a TRX is designated as being a dedicated BCCH, it shall be allocated to RF channel M. All remaining TRXs shall be allocated in the following order; first to RF channel B, then to T, then distributed as evenly as possible throughout the BSS operating transmit band. Slow frequency hopping shall be disabled.
- b) The transmitter antenna connector shall be connected to a spectrum analyser or selective volt meter with the same characteristic impedance.

The detecting device shall be configured with a resolution and video bandwidth of 100 kHz. The minimum sweep time shall be at least 75 ms and the response shall be averaged over 200 sweeps.

The power shall be measured for the following frequency band:

- the band 1900 - 1920 MHz.

- the band 1920 - 1980 MHz.
 - the band 2010 - 2025 MHz.
 - the band 2110 - 2170 MHz.
- c) The BSS shall be configured with all transmitters active at their maximum output power on all time slots. If a TRX is designated as being a dedicated BCCH, it shall be allocated to RF channel M. All remaining TRXs shall be allocated in the following order; first to RF channel B, then to T, then distributed as evenly as possible throughout the BSS operating transmit band. Slow frequency hopping shall be disabled.
- d) If the manufacturer declares that the BSS is suitable for the co-siting with UTRA BTS the following test shall be performed (with configuration according to step c) :

The transmitter antenna connector shall be connected to a spectrum analyser or selective volt meter with the same characteristic impedance.

The detecting device shall be configured with a resolution and video bandwidth of 100 kHz. The minimum sweep time shall be at least 75 ms and the response shall be averaged over 200 sweeps.

The power shall be measured for the following frequency band:

- the band 1900 - 1920 MHz and 2010 – 2025 MHz for a BTS intended for co-siting with a UTRA/TDD BS.
- the band 1920 - 1980 MHz for a BTS intended for co-siting with a UTRA/FDD BS.

6.6.2.3.3 Essential conformance

Test Environment

Normal:

Conformance requirement

The maximum power measured at step b) shall not exceed -62 dBm.

6.6.2.3.4 Complete conformance

Test Environment

Normal:

Conformance requirement

- 1) The maximum power measured at step b) shall not exceed -62 dBm.
- 2) If the manufacturer declares that the BSS is suitable for co-siting with one or more types of UTRA BTS, the power measured in step d) shall not exceed -96 dBm.

6.6.2.3.5 Requirement Reference

GSM 05.05 (EN 300 910) [22] subclauses 4.3.2

6.7 Intermodulation attenuation (GSM 400, GSM 900 and DCS 1800)

6.7.1 Test purpose

To verify that the RF transmit equipment is able to restrict the generation of signals in its non-linear elements caused by the presence of the RF output from the transmitter and an interfering signal reaching the transmitter via its antenna to below specified levels.

6.7.2 Test case

If SFH is supported by the BSS, it shall be disabled during this measurement.

The Manufacturer shall declare how many TRXs the BSS supports. The BSS shall be configured with the maximum number of TRXs supported. The test shall be performed for the number of TRXs and the frequencies defined in the conformance requirement.

Only the TRX under test shall be active. All remaining TRXs shall be idle on an ARFCN within the transmit *operating* band for the BSS.

NOTE 1: It is particularly important, for a BSS which uses a tuned transmitter combiner, that all sections of the combiner are set to frequencies within the transmit *operating* band of the BSS during this test.

The antenna output of the RF transmit equipment under test, including the combiner, shall be connected to a coupling device, presenting to the RF equipment a load with an impedance of 50 ohms. The frequency of the test signal shall be within the transmit operating band (see subclause 4.2). The test signal shall be unmodulated and the frequency shall be X MHz offset from the frequency of the RF transmit equipment under test. The TRX under test shall be set to highest static power control level and the test signal power level shall be adjusted 30 dB below this value. The test signals are illustrated in figure 5. The power level of the test signal shall be measured at the antenna output end of the coaxial cable, when disconnected from the RF transmit equipment and then correctly matched into 50 ohms. The antenna output power of the RF transmit equipment shall be measured directly at the antenna output terminal connected to an artificial antenna. Intermodulation product frequencies in the relevant TX band and relevant RX band shall be identified and measured according to the following process.

For the measurements in the relevant RX band:

Use a measurement and filter bandwidth of 100 kHz, frequency scan mode, averaged over 200 sweeps, with a sweep time of at least 75 ms. The frequency offset X shall be chosen to cause the lowest order intermodulation product to fall in the operating RX band.

For measurements in the relevant TX band:

The measurement shall be made for frequency offsets X of: 0.8 MHz, 2.0 MHz, 3.2 MHz, 6.2 MHz. The power of all third and fifth order intermodulation products shall be measured. The method of measurement specified below depends on the frequency offset of the intermodulation product from the carrier frequency:

For measurements at frequency offsets from the active TRX of more than 6 MHz the peak power of any intermodulation components shall be measured with a bandwidth of 300 kHz, zero frequency span, over a time slot period. This shall be measured over sufficient time slots to ensure conformance according to methodology of annex A. The reference power for relative measurements is the power measured in a bandwidth of at least 300 kHz for the TRX under test.

For measurements at frequency offsets from the active TRX 1.8 MHz or less the intermodulation product power shall be measured selectively using video averaging over 50 to 90 % of the useful part of the time slot excluding the midamble. The averaging shall be over at least 200 time slots and only active bursts shall be included in the averaging process. The RF and video filter bandwidth of the measuring instrument shall be 30 kHz.

For measurements at frequency offsets in the range 1.8 to 6 MHz the intermodulation product power shall be measured in a frequency scan mode, with a minimum sweep time of 75 ms and averaged over 200 sweeps. The RF and video filter bandwidth of the measuring instrument shall be 100 kHz.

NOTE 2: When the above measurements are performed precautions should be taken, so that non-linearity in the selective measuring device does not influence the results appreciably. Furthermore it should be ensured that intermodulation components which may be generated by non-linear elements in the test equipment (e.g. signal generator, coupling device, selective measuring device) are sufficiently reduced. The RF transmit equipment under test and the test signal source should be physically separated in such a way that the measurement is not influenced by direct radiation. A possible measurement set-up is shown in annex B.2.

6.7.3 Essential Conformance

Test Environment

Normal:

The following tests shall be performed, depending on the number of TRXs supported by the BSS:

- 1 TRX: The TRX shall be tested at B, M, and T.
- 2 TRX: One test shall be performed on B, M, and T. Each TRX shall be tested at least once.
- 3 or more TRX: One TRX shall be tested at B, one at M and one at T.

Conformance requirement

At frequencies offset from the wanted signal carrier frequency by more than 6 MHz and up to the edge of the relevant transmit band, the intermodulation components measured shall not exceed -70 dBc or -36 dBm, whichever is the higher. 1 in 100 time slot periods may fail the requirement by up to 10 dB.

At frequencies offset from the wanted signal carrier frequency of less than 6 MHz, the requirements are that specified in 6.5.1.3, Continuous Modulation Spectrum. The exceptions given in subclause 6.5.1.3 also apply.

6.7.4 Complete conformance

Test Environment

Normal:

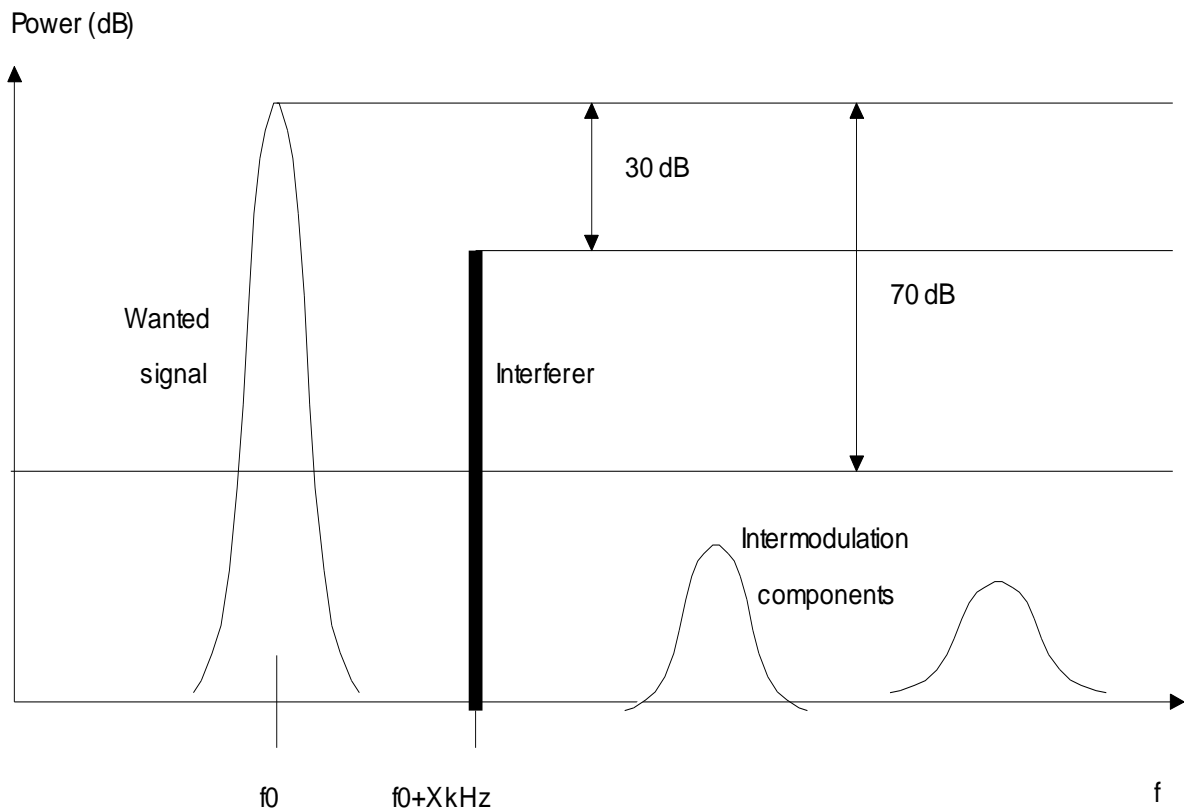

Figure 5: Example of TX intermodulation attenuation

Conformance requirement

The test shall be performed until three TRXs, or the maximum number supported by the BSS (whichever is the less) have each been tested at B, M, and T.

In the operating receive band the measured intermodulation components shall never exceed the values given in table 10 under normal test conditions.

Table 10: Maximum Receive Band transmitter intermodulation limits

	GSM 400, GSM 900 (dBm)	DCS 1800 (dBm)
Normal BTS	-98	-98
Micro-BTS M1	-91	-96
Micro-BTS M2	-86	-91
Micro-BTS M3	-81	-86
Pico-BTS P1	-70	-80
R-GSM900 BTS	-89	n/a
NOTE: Micro and pico-BTS is not defined for GSM400.		

At frequencies offset from the wanted signal carrier frequency by more than 6 MHz and up to the edge of the relevant transmit band, the intermodulation components measured shall not exceed -70 dBc or -36 dBm, whichever is the higher. 1 in 100 time slot periods may fail the requirement by up to 10 dB.

At frequencies offset from the wanted signal carrier frequency by less than 6 MHz, the requirements are that specified in subclause 6.5.1.3, Continuous Modulation Spectrum. The exceptions given in subclause 6.5.1.3 also apply.

6.7.5 Requirement reference

GSM 05.05 (EN 300 910) [22] subclause 4.7.1

6.8 Intra Base Station System intermodulation attenuation

6.8.1 Test purpose

To verify that the level of intermodulation products produced inside the RX and TX bands (due to the leakage of RF power between transmitters that are operating in close vicinity of each other inside the BSS, or are combined to feed a single antenna) do not exceed the specified limit. The test is not applicable for GSM 850, MXM 850, PCS 1900 and MXM 1900.

6.8.2 Test case

If SFH is supported by the BSS, it shall be disabled during this measurement.

The BSS shall be configured with a full complement of transceivers. Each RF transmit equipment shall be operated at the maximum power specified (Highest Static Power Control Level subclause 6.3) and with modulation of a pseudo random sequence applied.

In the relevant transmit band, the intermodulation components shall be measured at frequency offsets above the uppermost and below the lowermost carrier frequencies.

All intermodulation product frequencies in the relevant TX band and operating RX band shall be identified and measured according to the process below.

For the measurement in the operating RX band

The equipment shall be operated with ARFCNs such that the lowest order intermodulation product falls into the operating receive band. The measurement shall be carried out at the antenna connector of the BSS, using a frequency selective instrument.

A possible measurement set-up for this test is shown in annex B.2.

For measurements in the RX band the following is the test set up:

A filter and video bandwidth of 100 kHz.

Frequency scan mode.

Minimum sweep time of 75 ms and averaged over 200 sweeps.

For measurements in the relevant TX band

The equipment shall be operated at equal and minimum frequency spacing specified for the BSS configuration under test.

For frequency offsets of more than 6 MHz the peak power of any intermodulation components shall be measured with a bandwidth of 300 kHz, zero frequency span, over a time slot period. This shall be measured over sufficient time slots to ensure conformance according to methodology of annex A.1. The reference power for relative measurements is the power measured in a bandwidth of at least 300 kHz for the TRX under test.

For frequency offsets 1.8 MHz or less the intermodulation product power shall be measured selectively using video averaging over 50 to 90 % of the useful part of the time slot excluding the mid-amble. The averaging shall be over at least 200 time slots and only active bursts shall be included in the averaging process. The RF and video filter bandwidth of the measuring instrument shall be 30 kHz.

For frequency offsets in the range 1.8 to 6 MHz the intermodulation product power shall be measured in a frequency scan mode, with a minimum sweep time of 75 ms and averaged over 200 sweeps. The RF and video filter bandwidth of the measuring instrument shall be 100 kHz.

6.8.3 Essential conformance

Test Environment

Normal:

Conformance requirement

In the relevant transmit band, at offsets greater than 0.6 MHz and up to 6 MHz, the requirements are that specified in subclause 6.5.1, Continuous Modulation Spectrum. The exceptions given there shall also apply.

At frequencies offset from the wanted signal carrier frequency by more than 6 MHz and up to the edge of the relevant transmit band, the intermodulation components measured shall not exceed -70 dBc or -36 dBm, whichever is the higher. 1 in 100 time slot periods may fail the requirement by up to 10 dB.

6.8.4 Complete conformance

Test Environment

Normal:

Conformance requirement

In the operating receive band the measured intermodulation components shall never exceed the values given in table 11 under normal test conditions.

Table 11: Maximum intra-BSS Receive Band transmitter intermodulation limits

	GSM 400, GSM 850 and GSM 900 (dBm)	DCS 1800 and PCS 1900 (dBm)
Normal BTS	-98	-98
Micro-BTS M1	-91	-96
Micro-BTS M2	-86	-91
Micro-BTS M3	-81	-86
Pico-BTS P1	-70	-80
R-GSM 900 BTS	-89	n/a
NOTE: Micro and pico-BTS is not defined for GSM400.		

In the relevant transmit band, at offsets greater than 0.6 MHz and up to 6 MHz, the requirements are that specified in subclause 6.5.1, Continuous Modulation Spectrum. The exceptions given there shall also apply.

At frequencies offset from the wanted signal carrier frequency by more than 6 MHz and up to the edge of the relevant transmit band, the intermodulation components measured shall not exceed -70 dBc or -36 dBm, whichever is the higher. 1 in 100 time slot periods may fail the requirement by up to 10 dB.

6.8.5 Requirement reference

GSM 05.05 (EN 300 910) [22] subclause 4.7.2.

6.9 Intra Base Station System intermodulation attenuation, MXM 850 and MXM 1900

6.9.1 Test purpose

To verify that the level of intermodulation products (due to the leakage of RF power between transmitters that are operating in close vicinity of each other inside the BSS, or are combined to feed a single antenna) do not exceed the specified limit.

6.9.2 Test cases

6.9.2.1 200 kHz carriers-only

If SFH is supported by the BSS, it shall be disabled during this measurement.

The BSS shall be configured with a full complement of transceivers. Each RF transmit equipment shall be operated at the maximum power specified (Highest Static Power Control Level, subclause 6.3) and with modulation of a pseudo random sequence applied.

The equipment shall be operated at equal and minimum frequency spacing specified for the BSS configuration under test.

For frequency offsets above the uppermost and below the lowermost carrier frequencies of more than 1.2 MHz and within the relevant TX band the average power of any intermodulation components shall be measured with a bandwidth of 200 kHz, zero frequency span, over a time slot period. The reference power for relative measurements is the average power measured in a bandwidth of 300 kHz for the TRX under test.

6.9.2.2 200 kHz and ANSI-136 30 kHz carriers

A BSS comprised of both ANSI-136 30 kHz carriers (see TIA-EIA-136-C [25]) and 200 kHz carriers, shall be configured with a full complement of transceivers. Each RF transmit equipment shall be operated at the maximum power specified (Static Level 0 subclause 6.3 or, in the case of 30 kHz channels, as specified in TIA-EIA-136-C [25] part 280) and with modulation of a pseudo random sequence applied.

The equipment shall be operated at equal and minimum frequency spacing specified for each carrier type operating in the BSS configuration under test.

For frequency offsets above the uppermost and below the lowermost carrier frequencies, of more than 1.2 MHz and within the relevant TX band, the average power of any intermodulation components shall be measured as follows.

Two measurement types shall be made:

- (a) For each 30 kHz carrier, measure the reference average power, in a 30 kHz bandwidth and in accordance with TIA/EIA-136 part 280, section 3.4.4 [25]. Then, for all intermodulation products, measure, in a 30 kHz bandwidth and in average power mode, the power relative to the carrier reference power.
- (b) For each 200 kHz carrier, measure the reference average power, in a 300 kHz bandwidth and averaged over a time slot period in zero frequency span. Then, for all intermodulation products, measure, in a 200 kHz bandwidth and in average power mode, the power relative to the carrier reference power.

6.9.3 Essential conformance

This test need not be performed.

6.9.4 Complete conformance

Test Environment

Normal:

Conformance requirement

The average value of the measured intermodulation products shall not exceed:

- (a) -60 dBc, relative to the 30 kHz carrier average power and
- (b) -60 dBc, relative to the 200 kHz carrier average power.

6.9.5 Requirement reference

GSM 05.05 (EN 300 910) [22] subclause 4.7.2.

6.10 Intra Base Station System intermodulation attenuation, PCS 1900 and GSM 850

6.10.1 Test purpose

To verify that the level of intermodulation products produced inside the RX and TX bands (due to the leakage of RF power between transmitters that are operating in close vicinity of each other inside the BSS, or are combined to feed a single antenna) do not exceed the specified limit.

6.10.2 Test case

If SFH is supported by the BSS, it shall be disabled during this measurement.

The BSS shall be configured with a full complement of transceivers. Each RF transmit equipment shall be operated at the maximum power specified (Highest Static Power Control Level subclause 6.3) and with modulation of a pseudo random sequence applied.

All intermodulation product frequencies in the relevant TX band and operating RX band shall be identified and measured according to the process below.

For measurements in the relevant TX band

The equipment shall be operated at equal and minimum frequency spacing specified for the BSS configuration under test.

For frequency offsets 0.6 to 1.8 MHz the intermodulation product power shall be measured selectively using video averaging over 50 to 90 % of the useful part of the time slot excluding the mid-amble. The averaging shall be over at least 200 time slots and only active bursts shall be included in the averaging process. The RF and video filter bandwidth of the measuring instrument shall be 30 kHz.

For frequency offsets above the uppermost and below the lowermost carrier frequencies of more than 1.8 MHz the average power of any intermodulation components shall be measured with a bandwidth of 300 kHz, zero frequency span, over a time slot period. . The reference power for relative measurements is the power measured in a bandwidth of at least 300 kHz for the TRX under test. In the operating RX band the power of any intermodulation components shall be measured with a filter and video bandwidth of 100 kHz, frequency scan mode, minimum sweep time of 75 ms and averaged over 200 sweeps.

For the measurement in the operating RX band

The equipment shall be operated with ARFCNs such that the lowest order intermodulation product falls into the operating receive band. The measurement shall be carried out at the antenna connector of the BSS, using a frequency selective instrument.

A possible measurement set-up for this test is shown in annex B.2.

For measurements in the RX band the following is the test set up:

A filter and video bandwidth of 100 kHz.

Frequency scan mode.

Minimum sweep time of 75 ms and averaged over 200 sweeps.

6.10.3 Essential conformance

This test need not be performed.

6.10.4 Complete conformance

Test Environment

Normal:

Conformance requirement

In the operating receive band the measured intermodulation components shall never exceed the values given in table 11 under normal test conditions.

In the relevant transmit band, at offsets greater than 0.6 MHz and up to 1.8 MHz, the requirements are that specified in subclause 6.5.1, Continuous Modulation Spectrum except that for offset 1.2 MHz to 1.8 MHz the measured power shall not exceed -70 dBc. The exceptions given there shall also apply.

In the relevant transmit band for offsets greater than 1.8 MHz the measured power shall not exceed -70 dBc relative to the per carrier power or -46 dBm whichever is the higher.

6.10.5 Requirement reference

GSM 05.05 (EN 300 910) [22] subclause 4.7.2

6.11 Intermodulation attenuation (GSM 850, MXM 850, PCS 1900 and MXM 1900)

6.11.1 Test purpose

To verify that the RF transmit equipment is able to restrict the generation of signals in its non-linear elements caused by the presence of the RF output from the transmitter and an interfering signal reaching the transmitter via its antenna to below specified levels.

6.11.2 Test case

If SFH is supported by the BSS, it shall be disabled during this measurement.

The Manufacturer shall declare how many TRXs the BSS supports. The BSS shall be configured with the maximum number of TRXs supported. The test shall be performed for the number of TRXs and the frequencies defined in the conformance requirement.

Only the TRX under test shall be active. All remaining TRXs shall be idle on an ARFCN within the transmit *operating* band for the BSS.

NOTE 1: It is particularly important, for a BSS which uses a tuned transmitter combiner, that all sections of the combiner are set to frequencies within the transmit *operating* band of the BSS during this test.

The antenna output of the RF transmit equipment under test, including the combiner, shall be connected to a coupling device, presenting to the RF equipment a load with an impedance of 50 ohms. The frequency of the test signal shall be within the transmit operating band (see subclause 4.2). The test signal shall be unmodulated and the frequency shall be X MHz offset from the frequency of the RF transmit equipment under test. The TRX under test shall be set to highest static power control level and the test signal power level shall be adjusted 30 dB below this value. The test signals are illustrated in figure 5. The power level of the test signal shall be measured at the antenna output end of the coaxial cable, when disconnected from the RF transmit equipment and then correctly matched into 50 ohms. The antenna output power of the RF transmit equipment shall be measured directly at the antenna output terminal connected to an artificial antenna. Intermodulation product frequencies in the relevant TX band and relevant RX band shall be identified and measured according to the following process.

For the measurements in the relevant RX band:

Use a measurement and filter bandwidth of 100 kHz, frequency scan mode, averaged over 200 sweeps, with a sweep time of at least 75 ms. The frequency offset X shall be chosen to cause the lowest order intermodulation product to fall in the operating RX band.

For measurements in the relevant TX band:

The measurement shall be made for frequency offsets X of: 0.8 MHz, 2.0 MHz, 3.2 MHz, 6.2 MHz. The power of all third and fifth order intermodulation products shall be measured. The method of measurement specified below depends on the frequency offset of the intermodulation product from the carrier frequency:

For measurements at frequency offsets from the active TRX 1.8 MHz or less the intermodulation product power shall be measured selectively using video averaging over 50 to 90 % of the useful part of the time slot excluding the mid-amble. The averaging shall be over at least 200 time slots and only active bursts shall be included in the averaging process. The RF and video filter bandwidth of the measuring instrument shall be 30 kHz.

For measurements at frequency offsets from the active TRX more than 1.8 MHz the average power of any intermodulation components shall be measured with a bandwidth of 300 kHz, zero frequency span, over a time slot period. The reference power for relative measurements is the power measured in a bandwidth of at least 300 kHz for the TRX under test. In the operating RX band the power of any intermodulation components shall be measured with a filter and video bandwidth of 100 kHz, frequency scan mode, minimum sweep time of 75 ms and averaged over 200 sweeps.

6.11.3 Essential Conformance

Test Environment

Normal:

The following tests shall be performed, depending on the number of TRXs supported by the BSS:

- 1 TRX: The TRX shall be tested at B, M, and T.
- 2 TRX: One test shall be performed on B, M, and T. Each TRX shall be tested at least once.
- 3 or more TRX: One TRX shall be tested at B, one at M and one at T.

Conformance requirement

In the relevant transmit band for offsets greater than 1.8 MHz the measured power shall not exceed -70 dBc relative to the per carrier power or -46 dBm whichever is the higher.

In the relevant transmit band, at offsets greater than 0.6 MHz and up to 1.8 MHz, the requirements are that specified in subclause 6.5.1.3, Continuous Modulation Spectrum except that for offset 1.2 MHz to 1.8 MHz the measured power shall not exceed the requirements specified in subclause 6.5.1 or -70 dBc whichever higher. The exceptions in subclause 6.5.1.3 shall also apply.

6.11.4 Complete conformance

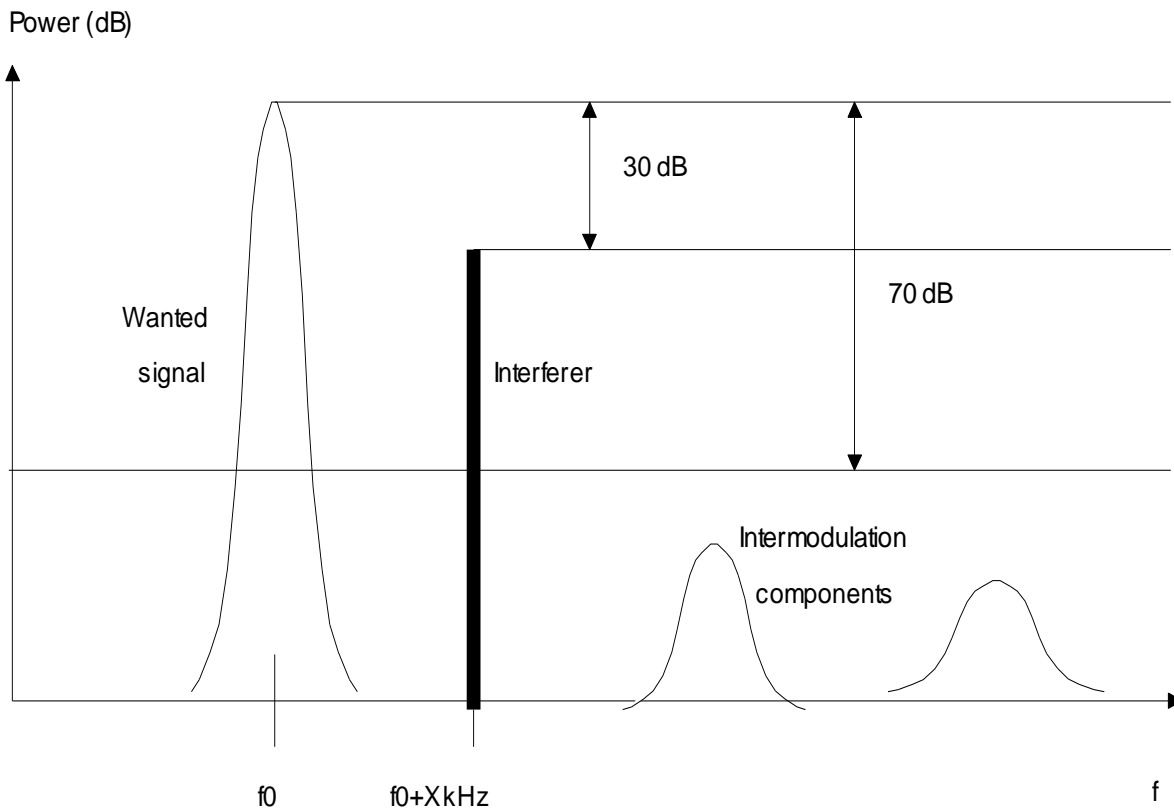

Figure 5a: Example of TX intermodulation attenuation

Test Environment

Normal:

Conformance requirement

The test shall be performed until three TRXs, or the maximum number supported by the BSS (whichever is the less) have each been tested at B, M, and T.

In the operating receive band the measured intermodulation components shall never exceed the values given in table 11a under normal test conditions.

Table 11a: Maximum Receive Band transmitter intermodulation limits

	GSM 850 and MXM 850 (dBm)	PCS 1900 and MXM 1900 (dBm)
Normal BTS	-98	-98
Micro-BTS M1	-91	-96
Micro-BTS M2	-86	-91
Micro-BTS M3	-81	-86
Pico-BTS P1	-70	-80

In the relevant transmit band, at offsets greater than 0.6 MHz and up to 1.8 MHz, the requirements are that specified in subclause 6.5.1.3, Continuous Modulation Spectrum except that for offset 1.2 MHz to 1.8 MHz the measured power shall not exceed the requirements specified in subclause 6.5.1 or -70 dBc whichever higher. The exceptions in subclause 6.5.1.3 shall also apply.

In the relevant transmit band for offsets greater than 1.8 MHz the measured power shall not exceed -70 dBc relative to the per carrier power or -46 dBm whichever is the higher.

6.11.5 Requirement reference

3GPP TS 05.05 subclause 4.7.1.

7 Receivers

All tests unless otherwise stated in this subclause shall be conducted on Base Station Systems fitted with a full complement of Transceivers for the configuration. The manufacturer shall provide appropriate logical or physical test access to perform all test in this subclause. Measurements shall include any RX multicoupler.

The tests in this subclause assume that the receiver is not equipped with diversity. For receivers with diversity, the tests may be performed by applying the specified signals to one of the receiver inputs, and terminating or disabling the other(s). The tests and requirements are otherwise unchanged.

For receivers with diversity, testing of essential conformance shall be performed by applying the specified signals to one of the receiver inputs, and terminating or disabling the other(s).

In all the relevant subclauses in this clause all Bit Error Ratio (BER), Residual BER (RBER), Block error Ratio (BLER) and Frame Erasure Ratio (FER) measurements shall be carried out according to the general rules for statistical testing in annex A.

7.1 Static Layer 1 receiver functions (nominal error ratios)

7.1.1 Test Purpose

The static Layer 1 receiver functions verified in these tests are the RF parts, the multiplexing and multiple access functions, any existing equalizer, the deciphering functions, the de-interleaving and the channel decoding on the receive side. The performance of the receiver at the maximum specified input level is also verified.

Nominal error ratios (Bit Error Ratio - BER) are measured at a logical reference point that represents the performance before channel decoding. This measurement can be performed for TCH/FS, using unprotected class II bits extracted after channel decoding, but before any extrapolation. Therefore, the results obtained are representative of the logical reference point before channel decoding. The test can also be performed on the uncoded bits extracted before any channel decoding of a PDTCH channel.

If the BTS supports SFH, this test also verifies the TCH/FS performance in frequency hopping under interference conditions. In this case, the Frame Erasure Ratio (FER) for TCH/FS is used as the performance criteria.

The Random access performance at high input levels is verified by measuring the Frame Erasure Ratio for RACH.

7.1.2 Test Case

GMSK modulation

- 1) For BER measurements, if Slow Frequency Hopping (SFH) is supported by the BSS, the BSS shall be hopping over the maximum range and number of ARFCNs possible for the test environment and which are available in the BSS configuration. If SFH is not supported, the test shall be performed for the radio frequency channels B, M and T. In both cases the tests shall be repeated until all the RF equipment in the BSS configuration is tested on all specified carrier frequencies.

If test is performed with TCH/FS a test signal with normal TCH/FS modulation originating from the BSSTE shall be applied to the BSS receiver input. The unprotected class II bits obtained from the BSS receiver after channel decoding and before any extrapolation shall be compared with the unprotected class II bits originating from the BSSTE.

If test is not performed with TCH/FS a test signal with normal PDTCH modulation originating from the BSSTE shall be applied to the BSS receiver input. The uncoded data bits obtained from the BSS receiver shall be compared with the bits originating from the BSSTE.

NOTE: Uncoded data bits refer to the encrypted bits of a burst, extracted by the receiver without any signal processing improvement from encoding/decoding of the signal.

The test shall be performed at the following power levels of test signal:

- a) A lower limit (20 dB above the reference sensitivity level of the BSS under test), as specified in table 12, for static propagation conditions.
 - b) -40 dBm, for static propagation conditions.
 - c) -15 dBm for GSM 400, GSM900, GSM850 and MXM 850 and -23 dBm for DCS1800, PCS 1900 and MXM 1900, for static propagation conditions only.
 - d) -5 dBm for GSM900, GSM850 and MXM 850 pico-BTS and -14 dBm for DCS1800, PCS 1900 and MXM 1900 pico-BTS, for static propagation conditions only.
 - e) A lower limit (20 dB above the reference sensitivity level of the BSS under test), as specified in table 12, for EQ50 propagation conditions, except for GSM 400 where EQ100 applies step e) does not apply to pico-BTS).
 - f) -40dBm, for EQ50 propagation conditions, except for GSM 400 where EQ100 applies step f) does not apply to pico-BTS).
- 2) For RACH, the test shall be performed for the radio frequency channels B, M and T. A test signal consisting of RACH bursts originating from the BSSTE shall be applied to the BSS receiver input. The proportion of RACH bursts at the input to the receiver which are not correctly identified by the BSS shall be measured.

The test shall be performed at the following power levels of test signal:

- a) A lower limit (20 dB above the reference sensitivity level of the BSS under test), as specified in table 12, for static propagation conditions.
 - b) -40 dBm, for static propagation conditions.
 - c) -15 dBm for GSM 400, GSM900, GSM850 and MXM 850 and -23 dBm for DCS1800, PCS 1900 and MXM 1900 for static propagation conditions.
- 3) For TCH/FS FER measurements in frequency hopping under interference conditions, two signals are connected to the BSS receiver input via a combining network. The wanted signal with an RF level given in table 12 shall be cyclically frequency hopping on four carrier frequencies under static conditions. The interfering signal shall be a random continuous, GMSK-modulated signal on only one of the carriers at a level 10 dB higher than the wanted signal.

The test shall be performed with the hopping frequencies centered around RF channel M.

8-PSK modulation

- 1) If Slow Frequency Hopping (SFH) is supported by the BSS, the BSS shall be hopping over the maximum range and number of ARFCNs possible for the test environment and which are available in the BSS configuration. If SFH is not supported, the test shall be performed for the radio frequency channels B, M and T. In either cases the tests shall be repeated until all the RF equipment in the BSS configuration is tested on all specified carrier frequencies.

A test signal with normal modulation originating from the BSSTE shall be applied to the BSS receiver input. The uncoded data bits obtained from the BSS receiver shall be compared with the bits originating from the BSSTE.

NOTE: Uncoded data bits refer to the encrypted bits of a burst, extracted by the receiver without any signal processing improvement from encoding/decoding of the signal.

The test shall be performed at the following power levels of test signal:

- a) A lower limit level, as specified in table 12, for static propagation conditions.
- b) -40dBm, for static propagation conditions.

- c) The maximum limit as specified in table 12, for static propagation conditions.
- d) Step a and b shall be repeated with the frequency of the input 8-PSK modulated signal randomly offset, by $\pm 0,1$ ppm (except $\pm 0,2$ ppm for GSM400), on a burst-by-burst basis. For each burst, the sign of the frequency offset is chosen according to a 511-bit pseudo-random sequence, defined in ITU-T recommendation O.153.

Table 12: Limit of RF input for testing of Static Layer 1 receiver functions

BTS Type	Lower Limit GMSK and 8-PSK	Maximum Limit 8-PSK
GSM 400/GSM850/GSM900/DCS1800/PCS 1900/MXM 850/MXM 1900 BTS	-84 dBm	-26 dBm
GSM900/GSM850/MXM 850 micro-BTS M1	-77 dBm	-24 dBm
GSM900/GSM850/MXM 850 micro-BTS M2	-72 dBm	-19 dBm
GSM900/GSM850/MXM 850 micro-BTS M3	-67 dBm	-14 dBm
GSM900/GSM850/MXM 850 pico-BTS P1	-68 dBm	-16 dBm
DCS1800/PCS 1900/ MXM 1900 micro-BTS M1	-82 dBm	-24 dBm
DCS1800/PCS 1900/ MXM 1900 micro-BTS M2	-77 dBm	-19 dBm
DCS1800/PCS 1900/ MXM 1900 micro-BTS M3	-72 dBm	-14 dBm
DCS1800/PCS 1900/ MXM 1900 pico-BTS P1	-75 dBm	-17 dBm

7.1.3 Essential conformance

This test need not be performed.

7.1.4 Complete conformance

Test Environment:

- Normal:**
- For GMSK BER measurements, each TRX shall be tested.
 - For RACH, the TRX supporting the BCCH shall be tested.
 - For 8-PSK modulation, each TRX shall be tested. Any 8-PSK modulated channel type can be used.
- Extreme Temperature:**
- For GMSK BER measurements, one TRX shall be tested on one timeslot, for static propagation conditions only.
 - For RACH, the TRX supporting the BCCH shall be tested.
 - For TCH/FS FER measurements, the test need not be performed.
 - For 8-PSK modulation, one TRX shall be tested on one timeslot, for static propagation conditions only. Any 8-PSK modulated channel type can be used.
- Vibration:**
- For GMSK BER measurements, one TRX shall be tested on one timeslot, for static propagation conditions only.
 - For TCH/FS FER measurements in frequency hopping under interference conditions and for RACH, the test need not be performed.
 - For 8-PSK modulation, one TRX shall be tested on one timeslot, for static propagation conditions only. Any 8-PSK modulated channel type can be used.

Conformance Requirement

The bit error ratio of the unprotected bits (TCH/FS, Class II or uncoded PDTCH bits) shall not exceed:

Static propagation conditions $BER \leq 10^{-4}$ For input levels up to -40 dBm

Static propagation conditions $BER \leq 10^{-3}$ For input levels > -40 dBm

EQ50 (except for GSM400, where EQ100 applies) propagation conditions $BER \leq 3\%$

The FER of TCH/FS under interfering conditions shall not exceed 5 %.

The frame erasure ratio of the RACH shall not exceed 0.5%.

The bit error ratio of uncoded data bits in 8-PSK channels shall not exceed:

Static propagation conditions (steps a, b and d) $BER \leq 10^{-4}$ for input levels up to 40 dBm.

Static propagation conditions (step c) $BER \leq 10^{-3}$ for input levels > -40 dBm.

7.1.5 Requirement Reference

GSM 05.05 (EN 300 910) [22] subclause 6.1, subclause 6.5 and subclause 6.6.

7.2 Erroneous Frame Indication Performance

7.2.1 Test Purpose

In GSM 05.03 (EN 300 909) [20] a Cyclic Redundancy Check (CRC) is defined for detection of erroneous Layer 2 frames or speech frames. For speech channels also additional error detecting capabilities using some soft information are needed due to DTX operation when no useful signal is transmitted to the receiver. This test verifies the reliability of the overall Bad Frame Indication (BFI) presented to the speech decoder and the Frame Erasure Indication (FEI) used on control channels.

7.2.2 Test Case

- 1) A test signal consisting of continuous GSM modulation of a pseudo random bit stream without mid-amble, and at a level specified in table 13, shall be applied to the receiver antenna connector, on the same frequency as the TRX under test.

One TRX shall be configured to support a BCCH. The detection by the BSS of error-free RACH bursts (FEI=0) shall be monitored by the BSSTE. If both GPRS is supported by the BSS and a PBCCH can be configured, then the detection by the BSS of error-free PRA CH bursts (FEI=0) shall be monitored by the BSS.

Table 13: Test Signal input level for testing of Erroneous Frame Indication performance

BTS Type	Test signal Input Level
GSM 400/GSM850/GSM900/DCS1800/PCS 1900/MXM 850/MXM 1900 BTS	-84 dBm
GSM900/GSM850/MXM 850 micro-BTS M1	-77 dBm
GSM900/GSM850/MXM 850 micro-BTS M2	-72 dBm
GSM900/GSM850/MXM 850 micro-BTS M3	-67 dBm
GSM900/GSM850/MXM 850 pico-BTS P1	-68 dBm
DCS1800/PCS 1900/ MXM 1900 micro-BTS M1	-82 dBm
DCS1800/PCS 1900/ MXM 1900 micro-BTS M2	-77 dBm
DCS1800/PCS 1900/ MXM 1900 micro-BTS M3	-72 dBm
DCS1800/PCS 1900/ MXM 1900 pico-BTS P1	-75 dBm

- 2) Step 1 shall be repeated without any RF input on the TRX under test, with the receiver antenna connector terminated with 50Ω .
- 3) Step 1 shall be repeated with one timeslot on one TRX configured for TCH/FS, TCH/HS, TCH/EFS, TCH/AxS and for FACCH. The Bad Frame Indication (BFI) shall be monitored by the BSSTE.
- 4) Step 3 shall be repeated without any RF input on the TRX under test, with the receiver antenna connector terminated with 50Ω .

- 5) The test shall be repeated with one timeslot on one TRX configured for TCH/FS, TCH/HS, TCH/EFS and TCH/AxS, when DTX is activated with SID frames and SACCH frames received at a level specified in table 13 and with no transmission at the other bursts of the TCH. The Bad Frame Indication (BFI) shall be monitored by the BSSTE.

7.2.3 Essential conformance

This test need not be performed.

7.2.4 Complete conformance

Test Environment:

Normal.

Conformance requirement

In steps 1 and 2, less than 0.02 % of the frames shall be detected as error free (FEI=0).

In steps 3, 4 and 5, less than 1 undetected bad speech frame (i.e. detected as BFI=0) shall occur on average in a period of 60 s.

7.2.5 Requirement reference

GSM 05.05 (EN 300 910) [22] subclause 6.4.

7.3 Static Reference Sensitivity Level

7.3.1 Test Purpose

The static reference sensitivity level of the receiver is the level of signal at the receiver input with a standard test signal at which the receiver will produce after demodulation and channel decoding data with a Frame Erasure Ratio (FER), Residual Bit Error Ratio (RBER) Bit Error Ratio (BER) or Block Error Ratio (BLER) better than or equal to that specified for a specific logical channel type under static propagation conditions.

7.3.2 Test Case

The test shall be performed for the specified ARFCNs. As a minimum, one time slot shall be tested on one TRX.

All TRXs in the BSS configuration shall be on and transmitting full power in all time slots.

For circuit switched channels, except ECSD with slow frequency hopping disabled, a test signal with normal GSM modulation shall be applied to the BSS RX antenna connector, with a power specified in table 14a, on a chosen time slot.

For packet switched channels and for ECSD with slow frequency hopping disabled, a test signal with normal GSM modulation shall be applied to the BSS RX antenna connector, with a power specified in table 14b, on a chosen time slot. For BTS types other than normal, the test signal input level shall be increased by the values in table 14c.

The two adjacent time slots shall have a level 50 dB above reference sensitivity requirement specified in table 14a. The content of this signal shall allow the receiver of the TRX under test to either be activated or to detect valid GMSK modulated GSM signals (as specified in the conformance requirement) on the adjacent timeslots for the duration of the test. No signal should be applied during the remaining timeslots.

If Synthesizer Slow Frequency Hopping is supported by the BSS, the test shall be repeated with the following changes:

- a) The BSS shall be hopping over the maximum range and number of ARFCNs possible for the test environment and which are available in the BSS configuration.

- b) The test signal should only be applied for the timeslot under test; no signal should be applied during the remaining timeslots.

Table 14a: Test Signal input level for Static reference sensitivity measurement for circuit switched channels except ECSD

BTS Type	Test signal Input Level GMSK
GSM 400/GSM850/GSM900/DCS1800/PCS 1900/MXM 850/MXM 1900 BTS	-104 dBm
GSM900/GSM850/MXM 850 micro-BTS M1	-97 dBm
GSM900/GSM850/MXM 850 micro-BTS M2	-92 dBm
GSM900/GSM850/MXM 850 micro-BTS M3	-87 dBm
GSM900/GSM850/MXM 850 pico-BTS P1	-88 dBm
DCS1800/PCS 1900/ MXM 1900 micro-BTS M1	-102 dBm
DCS1800/PCS 1900/ MXM 1900 micro-BTS M2	-97 dBm
DCS1800/PCS 1900/ MXM 1900 micro-BTS M3	-92 dBm
DCS1800/PCS 1900/ MXM 1900 pico-BTS P1	-95 dBm

Table 14b: Test Signal input level for Static reference sensitivity measurement for packet switched channels and ECSD

Normal BTS (GSM400, GSM850, GSM900, DCS1800, PCS1900, MXM850* , MXM1900*)		
Type of Channel		Static
PDTCH/CS-1 to 3	dBm	-104
PDTCH/CS-4	dBm	-101
PRACH/11 bits	dBm	-104
PRACH/8 bits	dBm	-104
PACCH	dBm	-104
PDTCH/MCS-1	dBm	-104
PDTCH/MCS-2	dBm	-104
PDTCH/MCS-3	dBm	-104
PDTCH/MCS-4	dBm	-101.5
PDTCH/MCS-5	dBm	-101
PDTCH/MCS-6	dBm	-99.5
PDTCH/MCS-7	dBm	-96
PDTCH/MCS-8	dBm	-93
PDTCH/MCS-9	dBm	-91.5
E-FACCH/F	dBm	-104
E-TCH/F43.2 (NT)	dBm	-97
E-TCH/F32 (T)	dBm	-104
E-TCH/F28.8 (T)	dBm	-99.5
E-TCH/F28.8 (NT)	dBm	-100

* NOTE: PDTCH/CS-1 to 4 and ECSD are not applicable for MXM850 and MXM1900

Table 14c: Test signal input level corrections for different BTS Types (for table 14b)

BTS Type	Test signal Average Input Level corrections
GSM400/GSM850/GSM900/MXM850 micro-BTS M1	+7 dB
GSM900/GSM850/MXM850 micro-BTS M2	+12 dB
GSM900/GSM850/MXM850 micro-BTS M3	+17 dB
GSM900/GSM850/MXM850 pico-BTS P1	+16 dB
DCS1800/PCS 1900/ MXM 1900 micro-BTS M1	+2 dB
DCS1800/PCS 1900/ MXM 1900 micro-BTS M2	+7 dB
DCS1800/PCS 1900/ MXM 1900 micro-BTS M3	+12 dB
DCS1800/PCS 1900/ MXM 1900 pico-BTS P1	+9 dB

The input signal before channel encoding in the BSSTE shall be compared with the signal which is obtained from the BSS receiver after channel decoding.

7.3.3 Essential conformance

Test Environment:

Normal.

Conformance Requirement

For tests with SFH disabled, the tests shall be performed at one ARFCN. For tests with SFH enabled, the tests shall be performed with the range of hopping frequencies centred around RF channel M.

The error performance given in table 15 shall be met for TCH/FS channel (FER and RBER for class Ib and class II bits) and TCH/HS channel (FER and RBER for class Ib and class II bits with BFI=0).

If GPRS is supported by the BSS, the error performance given in table 15 shall be met for PDTCH/CS-1 channel (BLER).

If AMR is supported by the BSS, the error performance given in table 15 shall be met for one channel. The channel with the highest bitrate shall be tested.

The error performance given in table 15 shall be met for PDTCH/MCS-5 or, if not supported, for the PDTCH/MCS-x with the next higher supported number x .

The error performance given in table 15 shall be met for E-TCH/F43.2 NT if supported or for the highest supported data speed.

For all tests where a signal is present on adjacent timeslots, the receiver of the TRX under test shall be activated for the duration of the test on the adjacent time slots. As a minimum, this shall include the automatic gain control (AGC) of the receiver being operational on the adjacent timeslots.

7.3.4 Complete conformance

Test Environment:

Normal.

Extreme Temperature: TCH/FS only, for one time slot of one transceiver.

Extreme power supply: TCH/FS only, for one time slot of one transceiver.

NOTE: tests under extreme power supply are carried out at extreme temperature limits.

Conformance Requirement

For tests with SFH disabled, the tests shall be performed at RF channels B, M, and T. For tests with SFH enabled, the tests shall be performed with the range of hopping frequencies centred around M.

The error performance given in table 15 shall be met for all logical channel types supported by the BSS.

For all tests where a signal is present on adjacent timeslots, the BTS shall detect valid GMSK modulated GSM signals with an RXQUAL of 6 or less for the duration of the test on the adjacent time slots.

Table 15: Static error performance limits at RX sensitivity level

Channel type:	Error Parameter	Limit Value
FACCH/H	FER	0,10 %
FACCH/F	FER	0,10 %
E-FACCH/F	FER	5 %
SDCCH and SACCH	FER	0,10 %
RACH	FER	0,50 %
E-TCH/F43,2 NT	BLER	10 %
E-TCH/F32,0 T	BER	0,1 %
E-TCH/F28,8 T	BER	0,1 %
E-TCH/F28,8 NT	BLER	10 %
TCH/F 14.4	BER	10 ⁻⁵
TCH/F9.6	BER	10 ⁻⁵
TCH/H4.8	BER	10 ⁻⁵
TCH/FS	FER	0,10 α %
- class Ib	RBER	0,40/ α %
- class II	RBER	2,0 %
TCH/HS	FER	0,025 %
- class Ib, BFI=0	RBER	0,001 %
- class II, BFI=0	RBER	0,72 %
-	UFR	0,048 %
- class Ib, UFI=0	RBER	0,001 %
-	EVSIDR	0,06 %
SID=0 and BFI=0	RBER	0,001 %
-	ESIDR	0,01 %
SID=1 or 2	RBER	0,003 %
TCH/EFS	FER	0,1 %
- class Ib	RBER	0,1 %
- class II	RBER	2,0 %
TCH/AFS12.2, class Ib	RBER	0,001 %
TCH/AFS10.2, class Ib	RBER	0,001 %
TCH/AHS7.95	FER	0,01 %
- class Ib	RBER	0,004 %
- class II	RBER	0,66 %
TCH/AHS7.4	FER	0,01 %
- class Ib	RBER	0,001 %
- class II	RBER	0,66 %
TCH/AHS6.7	FER	0,01 %
- class Ib	RBER	0,001 %
- class II	RBER	0,66 %
TCH/AHS5.9, class II	RBER	0,66 %
TCH/AHS5.15, class II	RBER	0,66 %
TCH/AHS4.75, class II	RBER	0,66 %
TCH/AHS-INB	FER	0,013 %
PDTCH/CS-1 to 4	BLER	10 %
PDTCH/MCS-1 to 9	BLER	10 %
PRACH/11 bits	BLER	15 %
PRACH/8 bits	BLER	15 %
PACCH	BLER	10 %

NOTE: The value of α in table 15 may be between 1 and 1.6, but should be the same for both occurrences.

7.3.5 Requirements Reference

GSM 05.05 (ETS 300 910) [22] subclause 6.2.

7.4 Multipath Reference Sensitivity Level

7.4.1 Test Purpose

The multipath reference sensitivity level of the receiver is the level of signal at the receiver input with a standard test signal at which the receiver will produce after demodulation and channel decoding data with a Frame Erasure Ratio (FER), Residual Bit Error Ratio (RBER), Bit Error Ratio (BER) or Block Error Ratio (BLER) better than or equal to that specified for a specific logical channel type, under multipath propagation conditions.

7.4.2 Test Case

As a minimum, one time slot shall be tested on one TRX.

A test signal with normal GSM modulation shall be applied to the BSS RX antenna connector through a Multipath Fading Simulator as described in annex B.1, on the chosen time slot.

For circuit switched channels, except ECSD, the average signal level at the receiver antenna connector of a BTS shall be as specified in table 16.

For packet switched channels (GPRS and EGPRS) and for ECSD, the average signal level at the receiver antenna connector of a normal BTS for which the reference performance shall be met is specified in table 16a, according to the type of channel and the propagation condition. For the TI5 propagation profile used for testing GSM 900 and DCS 1800 pico BTS P1 the column headed "TU50 (no FH)" shall be used. For BTS types other than normal, the levels specified in table 16a shall be increased by the values specified in table 16b.

In all cases, the average signal level at the receiver shall be measured by taking the mean powers of the sum of the individual paths.

All TRXs in the BSS configuration shall be on and transmitting full power in all time slots.

For tests with TU50 (ideal SFH):

The BSS shall be hopping over the maximum range and number of ARFCNs possible for the test environment and which are available in the BSS configuration.

For TU50 (no SFH), RA250 (no SFH), HT100 (no SFH) and TI5 (no SFH):

If slow frequency hopping is supported by the BSS, it shall be disabled. The test shall be performed for the specified ARFCNs. A test signal with GMSK modulation shall also be applied to the RX antenna connector on the two adjacent time slots at a static power level 50 dB above the reference sensitivity requirement specified in table 16 of the chosen time slot over the useful part of the burst as defined in GSM 05.05 (EN 300 910) [22] for the MS. The content of this signal shall allow the receiver of the TRX under test to either be activated or to detect valid GMSK modulated GSM signals (as specified in the conformance requirement) on the adjacent timeslots for the duration of the test.

Table 16: Test signal input level for Multipath Reference Sensitivity measurements for circuit switched channels except ECSD

BTS Type	Test signal Average Input Level to receiver
GSM 400/GSM850/GSM900/DCS1800/PCS 1900/MXM 850/MXM 1900 BTS	-104 dBm
GSM900/GSM850/MXM 850 micro-BTS M1	-97 dBm
GSM900/GSM850/MXM 850 micro-BTS M2	-92 dBm
GSM900/GSM850/MXM 850 micro-BTS M3	-87 dBm
GSM900/GSM850/MXM 850 pico-BTS P1	-85 dBm
DCS1800/PCS 1900/ MXM 1900 micro-BTS M1	-102 dBm
DCS1800/PCS 1900/ MXM 1900 micro-BTS M2	-97 dBm
DCS1800/PCS 1900/ MXM 1900 micro-BTS M3	-92 dBm
DCS1800/PCS 1900/ MXM 1900 pico-BTS P1	-92 dBm

Table 16a: Test signal input level for Multipath Reference Sensitivity measurements for packet switched and ECSD

Normal BTS (GSM 400, GSM 900, GSM 850 and MXM 850***)					
Type of Channel		Propagation conditions			
		TU50 (no FH)	TU50 (ideal FH)	RA250 (no FH)	HT100 (no FH)
PDTCH/CS-1	dBm	-104	-104	-104	-103
PDTCH/CS-2	dBm	-100	-101	-101	-99
PDTCH/CS-3	dBm	-98	-99	-98	-96
PDTCH/CS-4	dBm	-90	-90	*	*
PDTCH/MCS-1	dBm	-102.5	-103	-103	-102
PDTCH/MCS-2	dBm	-100.5	-101	-100.5	-100
PDTCH/MCS-3	dBm	-96.5	-96.5	-92.5	-95.5
PDTCH/MCS-4	dBm	-91	-91	*	*
PDTCH/MCS-5	dBm	-96.5	-97	-96	-95
PDTCH/MCS-6	dBm	-94	-94.5	-91	-91
PDTCH/MCS-7	dBm	-89	-88.5	-87**	-86**
PDTCH/MCS-8	dBm	-84	-84	*	-81.5**
PDTCH/MCS-9	dBm	-80	-80	*	*
E-TCH/F43,2 NT	dBm	-91	-92	-89	-89.5
E-TCH/F32,0 T	dBm	-97.5	-100	-100	-96.5
E-TCH/F28,8 T	dBm	-93.5	-95	-93.5	-94.5
E-TCH/F28,8 NT	dBm	-95.5	-96.5	-96.5	-96
E-FACCH/F	dBm	-101	-102	-102	-98
PRACH/11 bits	dBm	-104	-104	-103	-103
PRACH/8 bits	dBm	-104	-104	-103	-103
PACCH	dBm	-104	-104	-104	-103
Normal BTS (DCS 1800, PCS 1900 and MXM 1900***)					
Type of Channel		Propagation conditions			
		TU50 (no FH)	TU50 (ideal FH)	RA130 (no FH)	HT100 (no FH)
PDTCH/CS-1	dBm	-104	-104	-104	-103
PDTCH/CS-2	dBm	-100	-100	-101	-99
PDTCH/CS-3	dBm	-98	-98	-98	-94
PDTCH/CS-4	dBm	-88	-88	*	*
PDTCH/MCS-1	dBm	-102.5	-103	-103	-101.5
PDTCH/MCS-2	dBm	-100.5	-101	-100.5	-99.5
PDTCH/MCS-3	dBm	-96.5	-96.5	-92.5	-94.5
PDTCH/MCS-4	dBm	-90.5	-90.5	*	*
PDTCH/MCS-5	dBm	-95.5	-97	-96	-93
PDTCH/MCS-6	dBm	-94	-94	-91	-85.5
PDTCH/MCS-7	dBm	-87	-86.5	-87**	*
PDTCH/MCS-8	dBm	-86.5**	-86.5**	*	*
PDTCH/MCS-9	dBm	-83**	-83**	*	*
E-TCH/F43,2 NT	dBm	-91.5	-91.5	-88.5	-86
E-TCH/F32,0 T	dBm	-98.5	-100	-100	-97
E-TCH/F28,8 T	dBm	-94.5	-95	-92.5	-93
E-TCH/F28,8 NT	dBm	-96	-96.5	-96	-95
E-FACCH/F	dBm	-102	-102	-102	-98
PRACH/11 bits	dBm	-104	-104	-103	-103
PRACH/8 bits	dBm	-104	-104	-103	-103
PACCH	dBm	-104	-104	-104	-103

NOTE 1: PDTCH/CS-4 and MCS-x shall not be tested for the propagation conditions marked as (*).
NOTE 2: For GSM 400 the speeds shall be doubled (e.g. TU50 shall be TU100).
NOTE 3: Performance is specified at 30% BLER for those cases marked as (**)
***NOTE 4: PDTCH/CS-1 to 4 and ECSD are not applicable for MXM850 and MXM1900

Table 16b: Test signal input level corrections for different BTS Types (for table 16a)

BTS Type	Test signal Average Input Level corrections
GSM400/GSM850/GSM900/MXM850 micro-BTS M1	+7 dB
GSM900/GSM850/MXM850 micro-BTS M2	+12 dB
GSM900/GSM850/MXM850 micro-BTS M3	+17 dB
GSM900/GSM850/MXM850 pico-BTS P1	+19 dB
DCS1800/PCS 1900/ MXM 1900 micro-BTS M1	+2 dB
DCS1800/PCS 1900/ MXM 1900 micro-BTS M2	+7 dB
DCS1800/PCS 1900/ MXM 1900 micro-BTS M3	+12 dB
DCS1800/PCS 1900/ MXM 1900 pico-BTS P1	+12 dB

The input signal before channel encoding in the BSSTE shall be compared with the signal which is obtained from the BSS receiver after channel decoding.

7.4.3 Essential conformance

Test Environment:

Normal.

Normal and Micro-BTS Conformance Requirement

The error performance of TCH/FS shall be measured on RF channels B, M, and T for propagation profile TU50 (no SFH). The receiver of the TRX under test shall also be activated on the adjacent timeslots. As a minimum, this shall include the automatic gain control (AGC) of the receiver being operational on the adjacent timeslots.

The error performance of each of the following logical channel types supported by the BSS shall be measured, each on one ARFCN, for the specified propagation profiles:

TCH/FS: TU50 (no SFH), HT100, RA130 or RA250

TCH/HS (FER and RBER with BFI=0): TU50 (no SFH), HT100, RA130 or RA250

SDCCH: TU50 (no SFH), HT100, RA130 or RA250

TCH/F9.6: HT100, RA130 or RA250

TCH/F4.8: HT100, RA130 or RA250

PDTCH/CS-1: TU50(no SFH), HT100, RA130 or RA250

PDTCH/MCS-1 or, if not supported,
PDTCH/MCS-x with the
next higher supported number x: TU50(no SFH), HT100, RA130 or RA250

PDTCH/MCS-5 or, if not supported,
PDTCH/MCS-x with the
next higher supported number x: TU50(no SFH), HT100, RA130 or RA250

E-TCH/43.2 NT
or for the highest supported data speed: HT100, RA130 or RA250

The error performance given in table 17a-b shall be met for all combinations of logical channel type, frequency and multipath propagation profile tested.

If AMR is supported by the BSS, the error performance given in table 17a-b shall be met for one channel under TU50 (no SFH) propagation condition. The channel with the highest bitrate shall be tested.

Pico-BTS Conformance Requirement

The error performance of TCH/FS shall be measured on RF channels B, M, and T for propagation profile T15 (no SFH). The receiver of the TRX under test shall also be activated on the adjacent timeslots. As a minimum, this shall include the automatic gain control (AGC) of the receiver being operational on the adjacent timeslots.

The error performance of each of the following logical channel types supported by the BSS shall also be measured, each on one ARFCN, for propagation profile TI5 (no SFH) only:

TCH/HS (FER and RBER with BFI=0):	TI5
SDCCH:	TI5
TCH/F9.6:	TI5
TCH/F4.8:	TI5
PDTCH/CS-1	TI5
PDTCH/MCS-1 or, if not supported, for the PDTCH/MCS-x with the next higher supported number x:	TI5
PDTCH/MCS-5 or, if not supported, PDTCH/MCS-x with the next higher supported number x:	TI5
E-TCH/43.2NT or for the highest supported data speed.:	TI5

The error performance given in table 17a-b for the TI5 (no SFH) multipath propagation profile shall be met for all the above logical channel types tested.

If AMR is supported by the BSS, the error performance given in table 17a-b shall be met for one channel under TI5 propagation condition. The channel with the highest bitrate shall be tested.

7.4.4 Complete conformance

Test Environment:

Normal.

Normal and Micro-BTS Conformance Requirement

The error performance given in table 17 shall be met for all logical channel types supported by the BSS and for all the multipath propagation profiles (excluding TI5) given in table 17a-b.

For tests without SFH, the BTS shall detect valid GMSK modulated GSM signals with an RXQUAL of 6 or less for the duration of the test on the adjacent time slots.

Pico-BTS Conformance Requirement

The error performance given in table 17a-b for the TI5 (no SFH) multipath propagation profile shall be met for all logical channel types defined in table 17a-b.

Table 17a: GSM 400, GSM 850, GSM900 and MXM 850 Multipath error performance limits at RX sensitivity level

Channel Type	Error Measure	Error Ratios for the specified propagation conditions				
		TU50 (no SFH)	TU50 (ideal SFH)	RA250 (no SFH)	HT100 (no SFH)	TI5 (no SFH)
FACCH/H	(FER)	6.9 %	6.9 %	5.7 %	10.0 %	6.9 %
FACCH/F	(FER)	8.0 %	3.8 %	3.4 %	6.3 %	8.0 %
E-FACCH/F	(FER)	5 %	5 %	5 %	5 %	5 %
SDCCH and SACCH	(FER)	13 %	8.0 %	8.0 %	12.0 %	13 %
RACH	(FER)	13 %	13 %	12 %	13 %	13 %
E-TCH/F43,2 NT	(BLER)	10 %	10 %	10 %	10 %	10 %
E-TCH/F32,0 T	(BER)	0.1 %	0.1 %	0.1 %	0.1 %	0.1 %
E-TCH/F28,8 T	(BER)	0.1 %	0.1 %	0.1 %	0.1 %	0.1 %
E-TCH/F28,8 NT	(BLER)	10 %	10 %	10 %	10 %	10 %
TCH/F 14.4	(BER)	2.5%	2.0%	2.0%	5.0%	2.5 %
TCH/F9.6	(BER)	0.50 %	0.40 %	0.10 %	0.70 %	0.50 %
TCH/F4.8	(BER)	10 ⁻⁴	10 ⁻⁴	10 ⁻⁴	10 ⁻⁴	10 ⁻⁴
TCH/F2.4	(BER)	2 10 ⁻⁴	10 ⁻⁵	10 ⁻⁵	10 ⁻⁵	2 10 ⁻⁴
TCH/H4.8	(BER)	0.50 %	0.40 %	0.10 %	0.70 %	0.50 %
TCH/H2.4	(BER)	10 ⁻⁴	10 ⁻⁴	10 ⁻⁴	10 ⁻⁴	10 ⁻⁴
TCH/FS	(FER)	6.0 α %	3.0 α %	2.0 α %	7.0 α %	6.0 α %
- class Ib	(RBER)	0.40/ α %	0.30/ α %	0.20/ α %	0.50/ α %	0.40/ α %
- class II	(RBER)	8.0 %	8.0 %	7.0 %	9.0 %	8.0 %
TCH/HS	(FER)	4.1 %	4.1 %	4.1 %	4.5 %	4.1 %
- class Ib	(RBER, BFI=0)	0.36 %	0.36 %	0.28 %	0.56 %	0.36 %
- class II	(RBER, BFI=0)	6.9 %	6.9 %	6.8 %	7.6 %	6.9 %
-	(UFR)	5.6 %	5.6 %	5.0 %	7.5 %	5.6 %
- class Ib	(RBER, UFI=0)	0.24 %	0.24 %	0.21 %	0.32 %	0.24 %
-	(EVSIDR)	6.8 %	6.8 %	6.0 %	9.2 %	6.8 %
-	(RBER, SID=2 and BFI=0)	0.01 %	0.01 %	0.01 %	0.02 %	0.01 %
-	(ESIDR)	3.0 %	3.0 %	3.2 %	3.4 %	3.0 %
-	(RBER, SID=1 or 2)	0.3 %	0.3 %	0.21 %	0.42 %	0.3 %
TCH/EFS	(FER)	8 %	3 %	3 %	7%	8 %
- class Ib	(RBER)	0.21 %	0.11 %	0.10 %	0.20 %	0.21 %
- class II	(RBER)	7 %	8 %	7 %	9 %	7 %
TCH/AFS12.2	(FER)	4,9 %	2,4 %	1,4 %	4,5 %	4,9 %
- class Ib	(RBER)	1,5 %	1,5 %	1,2 %	2,1 %	1,5 %
TCH/AFS10.2	(FER)	2,1 %	0,85 %	0,45 %	1,6 %	2,1 %
- class Ib	(RBER)	0,23 %	0,15 %	0,092 %	0,26 %	0,23 %
TCH/AFS7.95	(FER)	0,36 %	0,045 %	0,024 %	0,096 %	0,36 %
- class Ib	(RBER)	0,11 %	0,032 %	0,02 %	0,06 %	0,11 %
TCH/AFS7.4	(FER)	0,41 %	0,069 %	0,028 %	0,13 %	0,41 %
- class Ib	(RBER)	0,054 %	0,016 %	0,009 %	0,033 %	0,054 %
TCH/AFS6.7	(FER)	0,16 %	0,017 %	0,01 %	0,026 %	0,16 %
- class Ib	(RBER)	0,082 %	0,022 %	0,013 %	0,044 %	0,082 %
TCH/AFS5.9	(FER)	0,094 %	0,01 %	0,01 %	0,011 %	0,094 %
- class Ib	(RBER)	0,014 %	0,001 %	0,001 %	0,003 %	0,014 %
TCH/AFS5.15	(FER)	0,07 %	0,01 %	0,01 %	0,01 %	0,07 %
- class Ib	(RBER)	0,014 %	0,001 %	0,001 %	0,002 %	0,014 %
TCH/AFS4.75	(FER)	0,029 %	0,01 %	-	0,01 %	0,029 %
- class Ib	(RBER)	0,005 %	0,001 %	0,001 %	0,001 %	0,005 %
TCH/AFS-INB	(FER)	0,034 %	0,013 %	0,002 %	0,019 %	0,034 %
TCH/AFS	(EVSIDUR)	0,82 %	0,17 %	0,17 %	0,17 %	0,82 %
TCH/AFS	(EVRFR)	0,095 %	0,007 %	0,007 %	0,011 %	0,095 %
TCH/AHS7.95	(FER)	20 %	20 %	17 %	28 %	20 %
- class Ib	(RBER)	2,3 %	2,3 %	2 %	2,9 %	2,3 %
- class II	(RBER)	5 %	5 %	4,7 %	5,7 %	5 %

Channel Type	Error Measure	Error Ratios for the specified propagation conditions				
		TU50 (no SFH)	TU50 (ideal SFH)	RA250 (no SFH)	HT100 (no SFH)	TI5 (no SFH)
TCH/AHS7.4	(FER)	16 %	16 %	14 %	22 %	16 %
- class Ib	(RBER)	1,4 %	1,4 %	1,1 %	1,8 %	1,4 %
- class II	(RBER)	5,3 %	5,3 %	5 %	6,0 %	5,3 %
TCH/AHS6.7	(FER)	9,2 %	9,2 %	8 %	13 %	9,2 %
- class Ib	(RBER)	1,1 %	1,1 %	0,93 %	1,5 %	1,1 %
- class II	(RBER)	5,8 %	5,8 %	5,5 %	6,6 %	5,8 %
TCH/AHS5.9	(FER)	5,7 %	5,7 %	4,9 %	8,6 %	5,7 %
- class Ib	(RBER)	0,51 %	0,51 %	0,42 %	0,73 %	0,51 %
- class II	(RBER)	6 %	6 %	5,7 %	6,8 %	6 %
TCH/AHS5.15	(FER)	2,5 %	2,5 %	2,2 %	4 %	2,5 %
- class Ib	(RBER)	0,51 %	0,51 %	0,43 %	0,78 %	0,51 %
- class II	(RBER)	6,3 %	6,3 %	6 %	7,2 %	6,3 %
TCH/AHS4.75	(FER)	1,2 %	1,2 %	1,2 %	1,8 %	1,2 %
- class Ib	(RBER)	0,17 %	0,17 %	0,14 %	0,26 %	0,17 %
- class II	(RBER)	6,4 %	6,4 %	6,2 %	7,4 %	6,4 %
TCH/AHS-INB	(FER)	0,72 %	0,64 %	0,53 %	0,94 %	0,72 %
TCH/AHS	(EVSIDUR)	1,5 %	1,5 %	2,1 %	1,5 %	1,5 %
TCH/AHS	(EVRFR)	0,25 %	0,24 %	0,33 %	0,38 %	0,25 %
PDTCH/CS-1 to 4	(BLER)	10%	10%	10%	10%	10 %
PDTCH/MCS-1 to 6	(BLER)	10%	10%	10%	10%	10%
PDTCH/MCS-7	(BLER)	10 %	10 %	30 %	30 %	10 %
PDTCH/MCS-8	(BLER)	10 %	10 %	-	30 %	10 %
PDTCH/MCS-9	(BLER)	10 %	10 %	-	-	10 %
PRACH/11 bits	(BLER)	15%	15%	15%	15%	15 %
PRACH/8 bits	(BLER)	15%	15%	15%	15%	15 %
PACCH	(BLER)	10%	10%	10%	10%	10 %

NOTE : For GSM 400 the speeds shall be doubled (e.g. TU50 shall be TU100).

Table 17b: DCS1800, PCS 1900 and MXM 1900 Multipath error performance limits at RX sensitivity level

Channel Type	Error Measure	Error Ratios for the specified propagation conditions				
		TU50 (no SFH)	TU50 (ideal SFH)	RA130 (no SFH)	HT100 (no SFH)	TI5 (no SFH)
FACCH/H	(FER)	7.2 %	7.2 %	5.7 %	10.4 %	6.9 %
FACCH/F	(FER)	3.9 %	3.9 %	3.4 %	7.4 %	8.0 %
E-FACCH/F	(FER)	5 %	5 %	5 %	5 %	5 %
SDCCH and SACCH	(FER)	9.0 %	9.0 %	8.0 %	13.0 %	13 %
RACH	(FER)	13 %	13 %	12 %	13 %	13 %
E-TCH/F43,2 NT	(BLER)	10 %	10 %	10 %	10 %	10 %
E-TCH/F32,0 T	(BER)	0.1 %	0.1 %	0.1 %	0.1 %	0.1 %
E-TCH/F28,8 T	(BER)	0.1 %	0.1 %	0.1 %	0.1 %	0.1 %
E-TCH/F28,8 NT	(BLER)	10 %	10 %	10 %	10 %	10 %
TCH/F14.4	(BER)	2.1%	2.0%	2.0%	6.5%	2.5%
TCH/F9.6	(BER)	0.40 %	0.40 %	0.10 %	0.70 %	0.50 %
TCH/F4.8	(BER)	10 ⁻⁴	10 ⁻⁴	10 ⁻⁴	10 ⁻⁴	10 ⁻⁴
TCH/F2.4	(BER)	10 ⁻⁵	10 ⁻⁵	10 ⁻⁵	10 ⁻⁵	2 10 ⁻⁴
TCH/H4.8	(BER)	0.40 %	0.40 %	0.10 %	0.70 %	0.50 %
TCH/H2.4	(BER)	10 ⁻⁴	10 ⁻⁴	10 ⁻⁴	10 ⁻⁴	10 ⁻⁴
TCH/FS	(FER)	3.0 α %	3.0 α %	2.0 α %	7.0 α %	6.0 α %
- class lb	(RBER)	0.30/ α %	0.30/ α %	0.20/ α %	0.50/ α %	0.40/ α %
- class II	(RBER)	8.0 %	8.0 %	7.0 %	9.0 %	8.0 %
TCH/HS	(FER)	4.2 %	4.2 %	4.1 %	5.0 %	4.1 %
- class lb	(RBER, BFI=0)	0.38 %	0.38 %	0.28 %	0.63 %	0.36 %
- class II	(RBER, BFI=0)	6.9 %	6.9 %	6.8 %	7.8 %	6.9 %
-	(UFR)	5.7 %	5.7 %	5.0 %	8.1 %	5.6 %
- class lb	(RBER, UFI=0)	0.26 %	0.26 %	0.21 %	0.35 %	0.24 %
-	(EVSIDR)	7.0 %	7.0 %	6.0 %	9.9 %	6.8 %
-	(RBER, SID=2 and BFI=0)	0.01 %	0.01 %	0.01 %	0.02 %	0.01 %
-	(ESIDR)	3.0 %	3.0 %	3.2 %	3.9 %	3.0 %
-	(RBER, SID=1 or 2)	0.33 %	0.33 %	0.21 %	0.45 %	0.3 %
TCH/EFS	(FER)	4 %	4 %	3 %	7%	8 %
- class lb	(RBER)	0.12 %	0.12 %	0.10 %	0.24 %	0.21 %
- class II	(RBER)	8 %	8 %	7 %	9 %	7 %
TCH/AFS12.2	(FER)	2 %	2,0 %	1,3 %	4,6 %	4,9 %
- class lb	(RBER)	1,4 %	1,4 %	1,2 %	2,1 %	1,5 %
TCH/AFS10.2	(FER)	0,65 %	0,65 %	0,41 %	1,6 %	2,1 %
- class lb	(RBER)	0,12 %	0,12 %	0,084 %	0,26 %	0,23 %
TCH/AFS7.95	(FER)	0,025 %	0,025 %	0,018 %	0,089 %	0,36 %
- class lb	(RBER)	0,023 %	0,023 %	0,016 %	0,061 %	0,11 %
TCH/AFS7.4	(FER)	0,036 %	0,036 %	0,023 %	0,13 %	0,41 %
- class lb	(RBER)	0,013 %	0,013 %	0,007 %	0,031 %	0,054 %
TCH/AFS6.7	(FER)	0,01 %	0,01 %	0,01 %	0,031 %	0,16 %
- class lb	(RBER)	0,017 %	0,017 %	0,01 %	0,041 %	0,082 %
TCH/AFS5.9	(FER)	0,01 %	0,01 %	0,01 %	0,01 %	0,094 %
- class lb	(RBER)	0,001 %	0,001 %	0,001 %	0,002 %	0,014 %
TCH/AFS5.15	(FER)	0,01 %	0,01 %	-	0,01 %	0,07 %
- class lb	(RBER)	0,001 %	0,001 %	0,001 %	0,003 %	0,014 %
TCH/AFS4.75	(FER)	0,01 %	-	-	0,01 %	0,029 %
- class lb	(RBER)	0,001 %	0,001 %	0,001 %	0,001 %	0,005 %
TCH/AFS-INB	(FER)	0,011 %	0,011 %	0,006 %	0,021 %	0,034 %
TCH/AFS	(EVSIDUR)	0,19 %	0,19 %	0,17 %	0,25 %	0,82 %
TCH/AFS	(EVRFR)	0,007 %	0,007 %	0,002 %	0,01 %	0,095 %
TCH/AHS7.95	(FER)	20 %	20 %	17 %	27 %	20 %
- class lb	(RBER)	2,3 %	2,3 %	2 %	2,9 %	2,3 %
- class II	(RBER)	5 %	5 %	4,8 %	5,7 %	5 %
TCH/AHS7.4	(FER)	16 %	16 %	13 %	22 %	16 %
- class lb	(RBER)	1,4 %	1,4 %	1,1 %	1,9 %	1,4 %

Channel Type	Error Measure	Error Ratios for the specified propagation conditions				
		TU50 (no SFH)	TU50 (ideal SFH)	RA130 (no SFH)	HT100 (no SFH)	TI5 (no SFH)
- class II	(RBER)	5,3 %	5,3 %	5,1 %	6,0 %	5,3 %
TCH/AHS6.7	(FER)	9,4 %	9,4 %	7,5 %	13 %	9,2 %
- class Ib	(RBER)	1,1 %	1,1 %	0,92 %	1,5 %	1,1 %
- class II	(RBER)	5,8 %	5,8 %	5,5 %	6,6 %	5,8 %
TCH/AHS5.9	(FER)	5,9 %	5,9 %	4,6 %	8,5 %	5,7 %
- class Ib	(RBER)	0,52 %	0,52 %	0,39 %	0,72 %	0,51 %
- class II	(RBER)	6,1 %	6,1 %	5,8 %	6,8 %	6 %
TCH/AHS5.15	(FER)	2,6 %	2,6 %	2 %	3,7 %	2,5 %
- class Ib	(RBER)	0,53 %	0,53 %	0,4 %	0,76 %	0,51 %
- class II	(RBER)	6,3 %	6,3 %	6,1 %	7,2 %	6,3 %
TCH/AHS4.75	(FER)	1,2 %	1,2 %	1,1 %	1,7 %	1,2 %
- class Ib	(RBER)	0,18 %	0,18 %	0,13 %	0,25 %	0,17 %
- class II	(RBER)	6,5 %	6,5 %	6,2 %	7,3 %	6,4 %
TCH/AHS-INB	(FER)	0,64 %	0,64 %	0,53 %	0,94 %	0,72 %
TCH/AHS	(EVSIDUR)	1,3 %	1,3 %	2,1 %	1,5 %	1,5 %
TCH/AHS	(EVRFR)	0,24 %	0,24 %	0,25 %	0,24 %	0,25 %
PDTCH/CS-1 to 4	(BLER)	10%	10%	10%	10%	10 %
PDTCH/MCS-1 to 6	(BLER)	10%	10%	10%	10%	10%
PDTCH/MCS-7	(BLER)	10 %	10 %	30 %	-	10 %
PDTCH/MCS-8	(BLER)	30 %	30 %	-	-	30 %
PDTCH/MCS-9	(BLER)	30 %	30 %	-	-	30 %
PRACH/11 bit	(BLER)	15%	15%	15%	15%	15 %
PRACH/8 bit	(BLER)	15%	15%	15%	15%	15 %
PACCH	(BLER)	10%	10%	10%	10%	10 %

The value of α in table 17a,b shall be between 1 and 1.6, and shall be the same for both occurrences in each propagation condition; it may be different for different propagation conditions.

NOTE: For each TU50 (ideal FH), sufficient decorrelation may be achieved with 4 frequencies spaced over 5 MHz.

7.4.5 Requirement Reference

GSM 05.05 (EN 300 910) [22] subclause 6.2.

7.5 Reference interference level

7.5.1 Test Purpose

The reference interference level is a measure of the capability of the receiver to receive a wanted modulated signal without exceeding a given degradation due to the presence of an unwanted modulated signal at the same carrier frequency (co-channel interference) or at any adjacent carrier frequencies (adjacent channel interference).

7.5.2 Test Case

If Slow Frequency Hopping (SFH) is supported by the BSS, it shall be disabled during this measurement, except when performing tests using propagation conditions with ideal SFH.

When SFH is used in the test, the BSS shall hop over the maximum range and number of ARFCNs possible for the test environment and which are available in the BSS configuration. If SFH is not supported, the test shall be performed on the specified number of ARFCNs. As a minimum, one time slot shall be tested on one TRX.

Two input signals shall be connected to the receiver via a combining network. When testing each signal shall be connected through a Multipath Fading Simulator (MFS) as described in annex B.1, except in the cases of frequency offsets of the interfering signal from the wanted signal of 400kHz or greater, where the interferer shall be static. The two multipath fading propagation conditions shall be uncorrelated.

The referred power level for both signals shall be the average power into the BSS RX antenna connector. This shall be measured by taking the mean powers of the sum of the individual paths.

For GMSK modulated circuit switched channels, the wanted signal shall have the power level as defined in table 18. It shall have normal GSM modulation. In the case of a pico-BTS, the power level defined in table 18 (*) shall be 4dB greater for measurements performed with interferer offsets of 400kHz or greater.

For packet switched channels and for ECSD, the wanted signal level shall be $(X-9dB+Ir)$, where "X" is the power level defined in table 18 and "Ir" is the co-channel interference ratio defined in table 19b.

Table 18: Test signal average input level for Reference Interference Level measurements

BTS Type	Test signal average input level to receiver
GSM 400/GSM850/GSM900/DCS1800/PCS 1900/MXM 850/MXM 1900 BTS	-84 dBm
GSM900/GSM850/MXM 850 micro-BTS M1	-77 dBm
GSM900/GSM850/MXM 850 micro-BTS M2	-72 dBm
GSM900/GSM850/MXM 850 micro-BTS M3	-67 dBm
GSM900/GSM850/MXM 850 pico-BTS P1	-68 dBm *
DCS1800/PCS 1900/ MXM 1900 micro-BTS M1	-82 dBm
DCS1800/PCS 1900/ MXM 1900 micro-BTS M2	-77 dBm
DCS1800/PCS 1900/ MXM 1900 micro-BTS M3	-72 dBm
DCS1800/PCS 1900/ MXM 1900 pico-BTS P1	-75 dBm *

The interfering signal shall be continuous and have GSM modulation of a pseudo-random bitstream without midamble. If the TRX supports 8-PSK it shall be tested with the interfering signal having GMSK modulation and with the interfering signal having 8-PSK modulation, unless it can be demonstrated that it is sufficient to test either with GMSK or 8-PSK modulated interfering signal. If the TRX does not support 8-PSK it shall be tested with the interfering signal having GMSK modulation. For SFH this interferer shall consist of either one signal which hops in synchronization with the time slot under test or a number of fixed frequency signal sources. In the latter case the number of interfering sources determines the number of frequencies over which the time slot under test can hop in the test environment irrespective of the upper limit of the BTS.

For GMSK modulated circuit switched channels, the test shall be performed with frequency offsets of the interfering signal from the wanted signal, for a relative level of interfering signal above the wanted signal as specified in table 19.

For packet switched channels and ECSD, the test shall be performed with frequency offsets of the interfering signal from the wanted signal, for a carrier to interferer ratio, relative to the co-channel interference ratio (C/Ic), as specified in table 19a. The minimum co-channel interference ratio (C/Ic) for all the combinations of packet switched logical channel type and propagation condition are as specified in table 19b.

In the case of Slow Frequency Hopping (SFH) the interfering signal shall be on the same ARFCN as the wanted signal over the useful part of the time slot burst. For offsets greater than 0 kHz only the multipath propagation condition TU50 (no SFH) need be tested for normal and micro-BTS systems, and only the multipath propagation condition TI5 (no SFH) need be tested for pico-BTS systems.

Table 19: Co-channel and adjacent channel interference rejections for circuit switched channels except ECSD

Interferers offset:	Carrier to Interferer Ratio:		Fading of interferer
	Normal and Micro-BTS	Pico-BTS	
0 kHz	9 dB	13 dB	yes
200 kHz	-9 dB	-5 dB	yes
400 kHz	-41 dB	-37dB	no

Table 19a: Co-channel and adjacent channel interference ratios for packet switched channels and for ECSD

Interferers offset:	Carrier to Interferer Ratio	Carrier to Interferer Ratio	Fading of interferer
	GMSK	8-PSK	
0 kHz	C/Ic (table 19b)	C/Ic (table 19b)	yes
200 kHz	C/Ic - 18 dB	Table 19c	yes
400 kHz	C/Ic - 50 dB	C/Ic - 50 dB	yes

Table 19b: Co-channel interference ratios (C/I_c) for packet switched channels and for ECSD

GSM 400, GSM900, GSM 850 and MXM 850***						
Channel Type	Unit	Carrier to Interferer Ratios for specified propagation conditions				
		TU3 (no SFH)	TU50 (no SFH)	TU50 (ideal SFH)	RA250 (no SFH)	T15 (no SFH)
PDTCH/CS-1	dB	13	10	9	9	14
PDTCH/CS-2	dB	15	14	13	13	18
PDTCH/CS-3	dB	16	16	15	16	20
PDTCH/CS-4	dB	21	24	24	*	27
PDTCH/MCS-1	dB	13	10.5	9.5	10	14.5
PDTCH/MCS-2	dB	15	12.5	12	12	16.5
PDTCH/MCS-3	dB	16.5	17	17	19	21
PDTCH/MCS-4	dB	19	22	22	*	26
PDTCH/MCS-5	dB	18	15.5	14.5	16	19.5
PDTCH/MCS-6	dB	20	18	17.5	21	22
PDTCH/MCS-7	dB	23.5	24	24.5	26.5**	28
PDTCH/MCS-8	dB	28.5	30	30	*	34
PDTCH/MCS-9	dB	30	33	35	*	37
E-TCH/F43,2 NT	dB	24	19.5	19	21.5	23.5
E-TCH/F32,0 T	dB	25.5	17	15.5	15.5	21
E-TCH/F28,8 T	dB	27	17.5	15.5	16	21.5
E-TCH/F28,8 NT	dB	20	14.5	13.5	13.5	18.5
E-FACCH/F	dB	17.5	12.5	11.5	11.5	16.5
PACCH	dB	13	10	9	9	14
PRACH/11 bits	dB	8	8	8	10	12
PRACH/8 bits	dB	8	8	8	9	12
DCS1800, PCS 1900 and MXM1900***						
Channel Type	Unit	Carrier to Interferer Ratios for specified propagation conditions				
		TU1.5 (no SFH)	TU50 (no SFH)	TU50 (ideal SFH)	RA130 (no SFH)	T15 (no SFH)
PDTCH/CS-1	dB	13	9	9	9	14
PDTCH/CS-2	dB	15	13	13	13	18
PDTCH/CS-3	dB	16	16	16	16	20
PDTCH/CS-4	dB	21	27	27	*	27
PDTCH/MCS-1	dB	13	10	9.5	10	14.5
PDTCH/MCS-2	dB	15	12	12	12	16.5
PDTCH/MCS-3	dB	16.5	17	18	19	21
PDTCH/MCS-4	dB	19	23	23	*	26
PDTCH/MCS-5	dB	18	15	15	16	19.5
PDTCH/MCS-6	dB	20	17.5	18	21	22
PDTCH/MCS-7	dB	23.5	26	26.5	27**	28
PDTCH/MCS-8	dB	28.5	25**	24.5**	*	34
PDTCH/MCS-9	dB	30	29**	29**	*	37
E-TCH/F43,2 NT	dB	24	19.5	19.5	22	23.5
E-TCH/F32,0 T	dB	25.5	16	15.5	15.5	21
E-TCH/F28,8 T	dB	27	16	16	17	21.5
E-TCH/F28,8 NT	dB	20	14	14	14.5	18.5
E-FACCH/F	dB	17.5	11.5	11.5	11.5	16.5
PACCH	dB	13	9	9	9	14
PRACH/11 bits	dB	9	9	9	10	12
PRACH/8 bits	dB	8	8	8	9	12

NOTE 1: PDTCH/CS-4 and MCS-x shall not be tested for the propagation conditions marked as (*).

NOTE 2: For GSM 400 the speeds shall be doubled (e.g. TU50 shall be TU100).

NOTE 3: Performance is specified at 30% BLER for those cases marked as (**).

***NOTE 4: PDTCH/CS-1 to 4 and ECSD are not applicable for MXM850 and MXM1900.

Table 19c: adjacent channel interference ratios (C/I_a) for EGPRS and ECSD channels

GSM 400, GSM900, GSM850 and MXM 850***						
Channel Type	Unit	Carrier to Interferer Ratios for specified propagation conditions				
		TU3 (no SFH)	TU50 (no SFH)	TU50 (ideal SFH)	RA250 (no SFH)	TI5 (no SFH)
PDTCH/MCS-5	dB	2.5	-2	-2	1	2
PDTCH/MCS-6	dB	4.5	1	1	6.5	5
PDTCH/MCS-7	dB	8	8.5	8.5	13.5**	12.5
PDTCH/MCS-8	dB	10.5	9**	9.5**	*	13**
PDTCH/MCS-9	dB	12	13.5**	13.5**	*	17.5**
E-TCH/F43,2 NT	dB	8	3.5	2.5	12	7.5
E-TCH/F32,0 T	dB	7.5	-2.5	-4	-4	1.5
E-TCH/F28,8 T	dB	10	0.5	-1	2.5	4.5
E-TCH/F28,8NT	dB	3.5	-1.5	-2.5	-0.5	2.5
DCS1800, PCS 1900 and MXM1900***						
Channel Type	Unit	Carrier to Interferer Ratios for specified propagation conditions				
		TU1.5 (no SFH)	TU50 (no SFH)	TU50 (ideal SFH)	RA130 (no SFH)	TI5 (no SFH)
PDTCH/MCS-5	dB	2.5	-2	-1.5	1	2
PDTCH/MCS-6	dB	4.5	1.5	1.5	6.5	5
PDTCH/MCS-7	dB	8	10.5	11	13.5**	12.5
PDTCH/MCS-8	dB	10.5	10**	9.5**	*	13**
PDTCH/MCS-9	dB	12	16**	16**	*	17.5**
E-TCH/F43,2 NT	dB	8	4	3.5	14	7.5
E-TCH/F32,0 T	dB	7	-3.5	-3.5	-4	1.5
E-TCH/F28,8 T	dB	10	-0.5	-0.5	5	4.5
E-TCH/F28,8NT	dB	3.5	-2	-2	0.5	2.5

NOTE 1: PDTCH/MCS-x shall not be tested for the propagation conditions marked as (*).
NOTE 2: For GSM 400 the speeds shall be doubled (e.g. TU50 shall be TU100).
NOTE 3: Performance is specified at 30% BLER for those cases marked as (**).
***NOTE 4: ECSD is not applicable for MXM850 and MXM1900.

All TRXs in the BSS configuration shall be on and transmitting full power in all time slots.

The input signal before channel encoding in the BSSTE shall be compared with the signal which is obtained from the BSS receiver after channel decoding.

7.5.3 Essential conformance

Test Environment:

Normal.

Normal and Micro-BTS Conformance Requirement

1) Co-channel:

The error performance shall be measured for TCH/FS channel (FER, class Ib and class II), for TU50 propagation condition. If synthesizer SFH is supported by the BSS, this shall be enabled, with the range of hopping frequencies centred around RF channel M. If synthesizer SFH is not supported, this shall be tested on one ARFCN channel.

With SFH disabled, the error performance for each of the following logical channel types supported by the BSS shall be measured, each on one ARFCN, for the specified propagation conditions:

TCH/FS:	TU1.5 or TU3
FACCH/F:	TU1.5 or TU3
FACCH/H:	TU1.5 or TU3
E-FACCH/F:	TU1.5 or TU3
SDCCH:	TU1.5 or TU3
TCH/F9.6:	TU1.5 or TU3, TU50
TCH/F4.8:	TU1.5 or TU3, TU50
PDTCH/CS-1:	TU1.5 or TU3, TU50
PDTCH/MCS-1 or, if not supported, for the PDTCH/MCS-x with the next higher supported number x:	TU1.5 or TU3, TU50
PDTCH/MCS-5 or, if not supported, PDTCH/MCS-x with the next higher supported number x:	TU1.5 or TU3, TU50
E-TCH/43,2 NT or for the highest supported data speed:	TU1.5 or TU3, TU50

If AMR is supported by the BSS, the error performance given in table 20a-b shall be met for one channel under TU50 (no SFH) propagation condition. The channel with the highest bitrate shall be tested.

2) 200 kHz offset:

With SFH disabled, the error performance for each of the following logical channel types supported by the BSS shall be measured, each on one ARFCN, for the specified propagation conditions:

TCH/FS:	TU50
FACCH/F:	TU50
E-TCH/43,2 NT or for the highest supported data speed or PDTCH/MCS-5 or, if not supported, PDTCH/MCS-x with the next higher supported number x:	TU50

3) 400 kHz offset:

With SFH disabled, the error performance for each of the following logical channel types supported by the BSS shall be measured, each on RF channels B, M and T, for the specified propagation conditions:

TCH/FS:	TU50
E-TCH/43,2 NT or for the highest supported data speed or PDTCH/MCS-5 or, if not supported, PDTCH/MCS-x with the next higher supported number x:	TU50

With SFH disabled, the error performance for each of the following logical channel types supported by the BSS shall be measured, each on one ARFCN, for the specified propagation profiles:

FACCH/F:	TU50
----------	------

In cases 1) and 2) above, the error performance given in table 20a-b shall be met for all combinations of logical channel type, frequency of wanted signal, 0kHz and 200kHz frequency offset of interfering signal and multipath propagation condition tested.

In case 3) above, the error performance given in table 20 a-b for EGPRS and ECSD channels and table 20c-d for other channels shall be met for all combinations of logical channel type, frequency of wanted signal, 400kHz frequency offset of interfering signal and multipath propagation condition tested.

The value of α in table 20a-d shall be in the range 1 to 1.6, and shall be the same for both occurrences in each propagation condition; it may be different for different propagation conditions.

Pico-BTS Conformance Requirement

1) Co-channel:

With SFH disabled, the error performance for each of the following logical channel types supported by the BSS shall be measured, each on one ARFCN, for the TI5 multipath propagation profile:

TCH/FS: TI5

FACCH/F: TI5

FACCH/H: TI5

E-FACCH/F: TI5

SDCCH: TI5

TCH/F9.6: TI5

TCH/F4.8: TI5

PDTCH/CS-1 TI5

PDTCH/MCS-1 or, if not supported,
PDTCH/MCS-x with the
next higher supported number x: TI5

PDTCH/MCS-5 or, if not supported,
PDTCH/MCS-x with the
next higher supported number x: TI5

E-TCH/43,2 NT
or for the highest supported data speed: TI5

If AMR is supported by the BSS, the error performance given in table 20a-b shall be met for one channel under TI5 propagation condition. The channel with the highest bitrate shall be tested.

2) 200 kHz offset:

With SFH disabled, the error performance for each of the following logical channel types supported by the BSS shall be measured, each on one ARFCN, for the TI5 multipath propagation profile:

TCH/FS: TI5

FACCH/F: TI5

E-TCH/43,2 NT or for the highest supported data speed
or PDTCH/MCS-5 or, if not supported,
PDTCH/MCS-x with the next
higher supported number x: TI5

3) 400 kHz offset:

With SFH disabled, the error performance for each of the following logical channel types supported by the BSS shall be measured, each on one ARFCN, for the TI5 multipath propagation profile:

TCH/FS: TI5

FACCH/F: TI5

E-TCH/43,2 NT

or for the highest supported data speed
or PDTCH/MCS-5 or, if not supported,
PDTCH/MCS-x with the next
higher supported number x: TI5

In cases 1) and 2) above, the error performance given in table 20 a-b shall be met for all combinations of logical channel type, frequency of wanted signal, 0kHz and 200kHz frequency offset of interfering signal and TI5 multipath propagation condition tested.

In case 3) above, the error performance given in table 20a-b for EGPRS and ECSD channels and table 20c-d for other channels shall be met for all combinations of logical channel type, frequency of wanted signal, 400kHz frequency offset of interfering signal and multipath propagation condition tested.

The value of α in table 20a-d shall be in the range 1 to 1.6, and shall be the same for both occurrences in the TI5 propagation condition.

7.5.4 Complete conformance

Test Environment:

Normal.

Normal and Micro-BTS Conformance Requirement

The error performance of any logical channel type supported by the BSS for any multipath propagation condition (excluding TI5) given in table 20a-d shall not be worse than the error ratios given in table 20a-d with the exception that for EGPRS and ECSD channels the requirements in table 20a-b apply. For the circuit switched control channels not listed in table 20 the requirements for the SDCCH shall apply. The requirements for propagation conditions with ideal SFH shall only apply if SFH is supported by the BSS.

For the propagation conditions with ideal SFH, the tests shall be performed with the range of hopping frequencies centred around RF channel M. For propagation conditions with no SFH, the tests shall be performed at the RF channels B, M, and T.

The value of α in table 20a-d shall be in the range 1 to 1.6, and shall be the same for both occurrences in each propagation condition; it may be different for different propagation conditions.

NOTE 1: For TU50 (ideal FH), sufficient decorrelation may be achieved with 4 frequencies spaced over 5 MHz.

Pico-BTS Conformance Requirement

The error performance of any logical channel type for the TI5 multipath propagation condition shall not be worse than the error ratios given in table 20a-d. The tests shall be performed with SFH disabled, at the RF channels B, M, and T. The value of α in table 20a-d shall be in the range 1 to 1.6, and shall be the same for both occurrences in the TI5 propagation condition.

Table 20a: GSM 400, GSM900, GSM 850 and MXM 850 Multipath error performance limits at RX interference level

Channel Type	Error Measure	Error Ratios for the specified propagation conditions				
		TU3 (no SFH)	TU50 (no SFH)	TU50 (ideal SFH)	RA250 (no SFH)	TI5 (no SFH)
FACCH/H	(FER)	22 %	6.7 %	6.7 %	5.7 %	6.7 %
FACCH/F	(FER)	22 %	9.5 %	3.4 %	3.5 %	9.5 %
E-FACCH/F	(FER)	5 %	5 %	5 %	5 %	5 %
SDCCH & SACCH	(FER)	22 % ⁽¹⁾	13 %	9 %	8.0 %	13 %
SACCH (TCH/AxS)	(FER @-3 dB)	40 % ⁽¹⁾	-	-	-	-
RACH	(FER)	15 %	16 %	16 %	13 %	16 %
E-TCH/F43,2 NT	(BLER)	10 %	10 %	10 %	10 %	10 %
E-TCH/F32,0 T	(BER)	0.1 %	0.1 %	0.1 %	0.1 %	0.1 %
E-TCH/F28,8 T	(BER)	0.1 %	0.1 %	0.1 %	0.1 %	0.1 %
E-TCH/F28,8 NT	(BLER)	10 %	10 %	10 %	10 %	10 %
TCH/F14.4	(BER)	10.0%	4.5%	3.0%	3.0%	4.5 %
TCH/F9.6	(BER)	8.0 %	0.80 %	0.30 %	0.2 %	0.80 %
TCH/F4.8	(BER)	3.0 %	10 ⁻⁴	10 ⁻⁴	10 ⁻⁴	10 ⁻⁴
TCH/F2.4	(BER)	3.0 %	10 ⁻⁴	10 ⁻⁵	10 ⁻⁵	10 ⁻⁴
TCH/H4.8	(BER)	8.0 %	0.80 %	0.30 %	0.20 %	0.80 %
TCH/H2.4	(BER)	4.0 %	2 10 ⁻⁴	10 ⁻⁴	10 ⁻⁴	2 10 ⁻⁴
TCH/FS	(FER)	21 α %	6.0 α %	3.0 α %	3.0 α %	6.0 α %
- class Ib	(RBER)	2.0/ α %	0.40/ α %	0.20/ α %	0.20/ α %	0.40/ α %
- class II	(RBER)	4.0 %	8.0 %	8.0 %	8.0 %	8.0 %
TCH/HS	(FER)	19.1 %	5.0 %	5.0 %	4.7 %	5.0 %
- class Ib	(RBER, BFI=0)	0.52 %	0.29 %	0.29 %	0.21 %	0.29 %
- class II	(RBER, BFI=0)	2.8 %	7.1 %	7.1 %	7.0 %	7.1 %
-	(UFR)	20.7 %	6.1 %	6.1 %	5.6 %	6.1 %
- class Ib	(RBER, UFI=0)	0.29 %	0.21 %	0.21 %	0.17 %	0.21 %
-	(EVSIDR)	21.9 %	7.0 %	7.0 %	6.3 %	7.0 %
-	(RBER, SID=2 and BFI=0)	0.02 %	0.01 %	0.01 %	0.01 %	0.01 %
-	(ESIDR)	17.1 %	3.6 %	3.6 %	3.4 %	3.6 %
-	(RBER, SID=1 or 2)	0.50 %	0.26 %	0.26 %	0.20 %	0.26 %
TCH/EFS	(FER)	23 %	9 %	3 %	4 %	9 %
- class Ib	(RBER)	0.20 %	0.20 %	0.10 %	0.13 %	0.20 %
- class II	(RBER)	3 %	7 %	8 %	8 %	7 %
TCH/AFS12.2	(FER)	22 %	6 %	3,5 %	2,5 %	6 %
- Class Ib	(RBER)	0,9 %	1,7 %	1,7 %	1,5 %	1,7 %
TCH/AFS10.2	(FER)	18 %	2,7 %	1,4 %	0,92 %	2,7 %
- Class Ib	(RBER)	0,53 %	0,3 %	0,21 %	0,16 %	0,3 %
TCH/AFS7.95	(FER)	13 % ⁽¹⁾	0,51 %	0,12 %	0,073 %	0,51 %
- Class Ib	(RBER)	0,66 % ⁽¹⁾	0,15 %	0,065 %	0,044 %	0,15 %
TCH/AFS7.95	(FER @-3dB)	26 % ⁽¹⁾	5,3 %	2,7 %	1,8 %	5,3 %
- Class Ib	(RBER @-3dB)	1,2 % ⁽¹⁾	1 %	0,78 %	0,6 %	1 %
TCH/AFS7.4	(FER)	14 % ⁽¹⁾	0,56 %	0,16 %	0,09 %	0,56 %
- Class Ib	(RBER)	0,43 % ⁽¹⁾	0,072 %	0,032 %	0,018 %	0,072 %
TCH/AFS7.4	(FER @-3dB)	26 % ⁽¹⁾	5,4 %	3,1 %	2 %	5,4 %
- Class Ib	(RBER @-3dB)	0,79 % ⁽¹⁾	0,52 %	0,38 %	0,28 %	0,52 %
TCH/AFS6.7	(FER)	11 % ⁽¹⁾	0,21 %	0,041 %	0,021 %	0,21 %
- Class Ib	(RBER)	0,75 % ⁽¹⁾	0,11 %	0,042 %	0,028 %	0,11 %
TCH/AFS6.7	(FER @-3dB)	23 % ⁽¹⁾	2,9 %	1,2 %	0,75 %	2,9 %
- Class Ib	(RBER @-3dB)	1,4 % ⁽¹⁾	0,86 %	0,6 %	0,44 %	0,86 %
TCH/AFS5.9	(FER)	10 % ⁽¹⁾	0,12 %	0,018 %	0,01 %	0,12 %
- Class Ib	(RBER)	0,38 % ⁽¹⁾	0,022 %	0,005 %	0,003 %	0,022 %
TCH/AFS5.9	(FER @-3dB)	21 % ⁽¹⁾	2 %	0,7 %	0,4 %	2 %
- Class Ib	(RBER @-3dB)	0,74 % ⁽¹⁾	0,23 %	0,12 %	0,079 %	0,23 %

Channel Type	Error Measure	Error Ratios for the specified propagation conditions				
		TU3 (no SFH)	TU50 (no SFH)	TU50 (ideal SFH)	RA250 (no SFH)	TI5 (no SFH)
TCH/AFS5.15	(FER)	9,2 % ⁽¹⁾	0,081 %	0,011 %	0,01 %	0,081 %
- Class Ib	(RBER)	0,44 % ⁽¹⁾	0,019 %	0,003 %	0,002 %	0,019 %
TCH/AFS5.15	(FER@-3dB)	19 % ⁽¹⁾	1,4 %	0,47 %	0,25 %	1,4 %
- Class Ib	(RBER@-3dB)	0,85 % ⁽¹⁾	0,22 %	0,11 %	0,069 %	0,22 %
TCH/AFS4.75	(FER)	7,9 % ⁽¹⁾	0,036 %	0,01 %	0,01 %	0,036 %
- Class Ib	(RBER)	0,32 % ⁽¹⁾	0,006 %	0,001 %	0,001 %	0,006 %
TCH/AFS4.75	(FER@-3dB)	17 % ⁽¹⁾	0,82 %	0,23 %	0,11 %	0,82 %
- Class Ib	(RBER@-3dB)	0,62 % ⁽¹⁾	0,11 %	0,033 %	0,019 %	0,11 %
TCH/AFS-INB	(FER)	1,5 % ⁽¹⁾	0,025 %	0,018 %	0,009 %	0,025 %
TCH/AFS-INB	(FER@-3dB)	3,5 % ⁽¹⁾	0,22 %	0,16 %	0,1 %	0,22 %
TCH/AFS	(EVSIDUR)	11 % ⁽¹⁾	1,4 % ⁽¹⁾	0,39 % ⁽¹⁾	0,46 % ⁽¹⁾	1,4 % ⁽¹⁾
TCH/AFS	(EVSIDUR@-3dB)	21 % ⁽¹⁾	6,3 % ⁽¹⁾	3,4 % ⁽¹⁾	3,1 % ⁽¹⁾	6,3 % ⁽¹⁾
TCH/AFS	(EVRFR)	10 % ⁽¹⁾	0,15 %	0,024 %	0,01 %	0,15 %
TCH/AFS	(EVRFR@-3dB)	21 % ⁽¹⁾	2,08 %	0,77 %	0,48 %	2,08 %
TCH/AHS7.95	(FER)	27 %	22 %	22 %	21 %	22 %
- Class Ib	(RBER)	0,84 %	2,3 %	2,3 %	2,1 %	2,3 %
- Class II	(RBER)	1,7 %	5,3 %	5,3 %	5 %	5,3 %
TCH/AHS7.95	(FER@+3dB)	14 %	6,7 %	6,7 %	7 %	6,7 %
- Class Ib	(RBER@+3dB)	0,48 %	1 %	1 %	1 %	1 %
- Class II	(RBER@+3dB)	1 %	3,2 %	3,2 %	3,2 %	3,2 %
TCH/AHS7.4	(FER)	25 %	18 %	18 %	17 %	18 %
- Class Ib	(RBER)	0,68 %	1,4 %	1,4 %	1,3 %	1,4 %
- Class II	(RBER)	1,9 %	5,6 %	5,6 %	5,4 %	5,6 %
TCH/AHS7.4	(FER@+3dB)	13 %	4,8 %	4,8 %	5,3 %	4,8 %
- Class Ib	(RBER@+3dB)	0,38 %	0,51 %	0,51 %	0,50 %	0,51 %
- Class II	(RBER@+3dB)	1,2 %	3,3 %	3,3 %	3,4 %	3,3 %
TCH/AHS6.7	(FER)	23 %	11 %	11 %	11 %	11 %
- Class Ib	(RBER)	0,71 %	1,2 %	1,2 %	1,1 %	1,2 %
- Class II	(RBER)	2,3 %	6,2 %	6,2 %	6 %	6,2 %
TCH/AHS6.7	(FER@+3dB)	11 %	2,3 %	2,3 %	2,9 %	2,3 %
- Class Ib	(RBER@+3dB)	0,39 %	0,39 %	0,39 %	0,4 %	0,39 %
- Class II	(RBER@+3dB)	1,4 %	3,6 %	3,6 %	3,6 %	3,6 %
TCH/AHS5.9	(FER)	21 %	7,1 %	7,1 %	7 %	7,1 %
- Class Ib	(RBER)	0,55 %	0,57 %	0,57 %	0,51 %	0,57 %
- Class II	(RBER)	2,6 %	6,5 %	6,5 %	6,3 %	6,5 %
TCH/AHS5.15	(FER)	17 %	3,3 %	3,3 %	3,5 %	3,3 %
- Class Ib	(RBER)	0,8 %	0,6 %	0,6 %	0,57 %	0,6 %
- Class II	(RBER)	3,1 %	6,9 %	6,9 %	6,7 %	6,9 %
TCH/AHS4.75	(FER)	15 %	1,8 %	1,8 %	2,1 %	1,8 %
- Class Ib	(RBER)	0,6 %	0,22 %	0,22 %	0,22 %	0,22 %
- Class II	(RBER)	3,6 %	7 %	7 %	6,9 %	7 %
TCH/AHS-INB	(FER)	2,7 % ⁽¹⁾	0,7 % ⁽¹⁾	0,7 % ⁽¹⁾	0,63 % ⁽¹⁾	0,7 % ⁽¹⁾
TCH/AHS-INB	(FER@-3dB)	6 % ⁽¹⁾	2,2 % ⁽¹⁾	2,2 % ⁽¹⁾	2 % ⁽¹⁾	2,2 % ⁽¹⁾
TCH/AHS	(EVSIDUR)	15 % ⁽¹⁾	2,5 % ⁽¹⁾	2,5 % ⁽¹⁾	3,8 % ⁽¹⁾	2,5 % ⁽¹⁾
TCH/AHS	(EVSIDUR@-3dB)	28 % ⁽¹⁾	15 % ⁽¹⁾	15 % ⁽¹⁾	15 % ⁽¹⁾	15 % ⁽¹⁾
TCH/AHS	(EVRFR)	11 % ⁽¹⁾	0,51 % ⁽¹⁾	0,51 % ⁽¹⁾	0,61 % ⁽¹⁾	0,51 % ⁽¹⁾
TCH/AHS	(EVRFR@-3dB)	22 % ⁽¹⁾	4,4 % ⁽¹⁾	4,4 % ⁽¹⁾	4,1 % ⁽¹⁾	4,4 % ⁽¹⁾
PDTCH/CS-1 to 4	(BLER)	10%	10%	10%	10%	10 %
PDTCH/MCS-1 to 6	(BLER)	10%	10%	10%	10%	10 %
PDTCH/MCS-7	(BLER)	10%	10%	10%	30%	10 %
PDTCH/MCS-8	(BLER)	10%	10%/30 %*	10%/30 %*	-	30 %
PDTCH/MCS-9	(BLER)	10%	10%/30 %*	10%/30 %*	-	30 %
PRACH/11 bit	(BLER)	15%	15%	15%	15%	15 %
PRACH/8 bit	(BLER)	15%	15%	15%	15%	15 %
PACCH	(BLER)	10%	10%	10%	10%	10 %

* Co-channel interference performance is defined at 10% BLER and adjacent channel interference performance at 30% BLER.

NOTE: For GSM 400 the speeds shall be doubled (e.g. TU50 shall be TU100).

Table 20b: DCS1800, PCS 1900 and MXM 1900 Multipath error performance limits at RX interference level

Channel Type	Error Measure	Error Ratios for the specified propagation conditions				
		TU1.5 (no SFH)	TU50 (no SFH)	TU50 (ideal SFH)	RA130 (no SFH)	TI5 (no SFH)
FACCH/H	(FER)	22 %	6.9 %	6.9 %	5.7 %	6.7 %
FACCH/F	(FER)	22 %	3.4 %	3.4 %	3.5 %	9.5 %
E-FACCH/F	(FER)	5	5 %	5 %	5 %	5 %
SDCCH & SACCH	(FER)	22 % ⁽¹⁾	9.0 %	9.0 %	8.0 %	13 %
SACCH (TCH/AxS)	(FER @-3 dB)	40 % ⁽¹⁾	-	-	-	-
RACH	(FER)	15 %	16 %	16 %	13 %	16 %
E-TCH/F43,2 NT	(BLER)	10 %	10 %	10 %	10 %	10 %
E-TCH/F32,0 T	(BER)	0.1 %	0.1 %	0.1 %	0.1 %	0.1 %
E-TCH/F28,8 T	(BER)	0.1 %	0.1 %	0.1 %	0.1 %	0.1 %
E-TCH/F28,8 NT	(BLER)	10 %	10 %	10 %	10 %	10 %
TCH/14.4	(BER)	10.0%	4.0%	3.1%	3.0%	4.5 %
TCH/F9.6	(BER)	8.0 %	0.80 %	0.30 %	0.2 %	0.80 %
TCH/F4.8	(BER)	3.0 %	10 ⁻⁴	10 ⁻⁴	10 ⁻⁴	10 ⁻⁴
TCH/F2.4	(BER)	3.0 %	10 ⁻⁵	10 ⁻⁵	10 ⁻⁵	10 ⁻⁴
TCH/H4.8	(BER)	8.0 %	0.80 %	0.30 %	0.20 %	0.80 %
TCH/H2.4	(BER)	4.0 %	10 ⁻⁴	10 ⁻⁴	10 ⁻⁴	2 10 ⁻⁴
TCH/FS	(FER)	21 α %	3.0 α %	3.0 α %	3.0 α %	6.0 α %
- class Ib	(RBER)	2.0/ α %	0.25/ α %	0.25/ α %	0.20/ α %	0.40/ α %
- class II	(RBER)	4.0 %	8.1 %	8.1 %	8.0 %	8.0 %
TCH/HS	(FER)	19.1 %	5.0 %	5.0 %	4.7 %	5.0 %
- class Ib	(RBER, BFI=0)	0.52 %	0.29 %	0.29 %	0.21 %	0.29 %
- class II	(RBER, BFI=0)	2.8 %	7.2 %	7.2 %	7.0 %	7.1 %
-	(UFR)	20.7 %	6.1 %	6.1 %	5.6 %	6.1 %
- class Ib	(RBER, UFI=0)	0.29 %	0.21 %	0.21 %	0.17 %	0.21 %
-	(EVSIDR)	21.9 %	7.0 %	7.0 %	6.3 %	7.0 %
-	(RBER, SID=2 and BFI=0)	0.02 %	0.01 %	0.01 %	0.01 %	0.01 %
-	(ESIDR)	17.1 %	3.6 %	3.6 %	3.4 %	3.6 %
-	(RBER, SID=1 or 2)	0.50 %	0.26 %	0.26 %	0.20 %	0.26 %
TCH/EFS	(FER)	23 %	3 %	3 %	4 %	9 %
- class Ib	(RBER)	0.20 %	0.10 %	0.10 %	0.13 %	0.20 %
- class II	(RBER)	3 %	8 %	8 %	8 %	7 %
TCH/AFS12.2	(FER)	22 %	2,7 %	2,7 %	1,8 %	6 %
- Class Ib	(RBER)	0,92 %	1,6 %	1,6 %	1,4 %	1,7 %
TCH/AFS10.2	(FER)	18 %	0,98 %	0,98 %	0,56 %	2,7 %
- Class Ib	(RBER)	0,54 %	0,17 %	0,17 %	0,12 %	0,3 %
TCH/AFS7.95	(FER)	13 % ⁽¹⁾	0,07 %	0,07 %	0,029 %	0,51 %
- Class Ib	(RBER)	0,67 % ⁽¹⁾	0,042 %	0,042 %	0,03 %	0,15 %
TCH/AFS7.95	(FER @-3dB)	25 % ⁽¹⁾	2 %	2 %	1,2 %	5,3 %
- Class Ib	(RBER @-3dB)	1,2 % ⁽¹⁾	0,68 %	0,68 %	0,48 %	1 %
TCH/AFS7.4	(FER)	14 % ⁽¹⁾	0,083 %	0,083 %	0,047 %	0,56 %
- Class Ib	(RBER)	0,43 % ⁽¹⁾	0,02 %	0,02 %	0,012 %	0,072 %
TCH/AFS7.4	(FER @-3dB)	26 % ⁽¹⁾	2,3 %	2,3 %	1,4 %	5,4 %
- Class Ib	(RBER @-3dB)	0,8 % ⁽¹⁾	0,32 %	0,32 %	0,22 %	0,52 %
TCH/AFS6.7	(FER)	11 % ⁽¹⁾	0,025 %	0,025 %	0,01 %	0,21 %
- Class Ib	(RBER)	0,76 % ⁽¹⁾	0,028 %	0,028 %	0,016 %	0,11 %
TCH/AFS6.7	(FER @-3dB)	22 % ⁽¹⁾	0,82 %	0,82 %	0,41 %	2,9 %
- Class Ib	(RBER @-3dB)	1,4 % ⁽¹⁾	0,51 %	0,51 %	0,34 %	0,86 %
TCH/AFS5.9	(FER)	10 % ⁽¹⁾	0,01 %	0,01 %	0,01 %	0,12 %
- Class Ib	(RBER)	0,38 % ⁽¹⁾	0,002 %	0,002 %	0,001 %	0,022 %
TCH/AFS5.9	(FER @-3dB)	21 % ⁽¹⁾	0,41 %	0,41 %	0,2 %	2 %

Channel Type	Error Measure	Error Ratios for the specified propagation conditions				
		TU1.5 (no SFH)	TU50 (no SFH)	TU50 (ideal SFH)	RA130 (no SFH)	TI5 (no SFH)
- Class I _b	(RBER@-3dB)	0,72 % ⁽¹⁾	0,079 %	0,079 %	0,046 %	0,23 %
TCH/AFS5.15	(FER)	9,2 % ⁽¹⁾	0,01 %	0,01 %	0,01 %	0,081 %
- Class I _b	(RBER)	0,45 % ⁽¹⁾	0,001 %	0,001 %	0,001 %	0,019 %
TCH/AFS5.15	(FER@-3dB)	19 % ⁽¹⁾	0,26 %	0,26 %	0,13 %	1,4 %
- Class I _b	(RBER@-3dB)	0,84 % ⁽¹⁾	0,072 %	0,072 %	0,038 %	0,22 %
TCH/AFS4.75	(FER)	7,9 % ⁽¹⁾	0,01 %	0,01 %	-	0,036 %
- Class I _b	(RBER)	0,31 % ⁽¹⁾	0,001 %	0,001 %	0,001 %	0,006 %
TCH/AFS4.75	(FER@-3dB)	17 % ⁽¹⁾	0,1 %	0,1 %	0,051 %	0,82 %
- Class I _b	(RBER@-3dB)	0,61 % ⁽¹⁾	0,021 %	0,021 %	0,009 %	0,11 %
TCH/AFS-INB	(FER)	1,5 % ⁽¹⁾	0,013 %	0,013 %	0,008 %	0,025 %
TCH/AFS-INB	(FER@-3dB)	3,5 % ⁽¹⁾	0,12 %	0,12 %	0,1 %	0,22 %
TCH/AFS	(EVSIDUR)	11 % ⁽¹⁾	0,3 %	0,3 %	0,36 % ⁽¹⁾	1,4 % ⁽¹⁾
TCH/AFS	(EVSIDUR@-3dB)	21 % ⁽¹⁾	2,8 %	2,8 %	2,8 % ⁽¹⁾	6,3 % ⁽¹⁾
TCH/AFS	(EVRFR)	10 % ⁽¹⁾	0,022 %	0,022 %	0,005 %	0,15 %
TCH/AFS	(EVRFR@-3dB)	21 % ⁽¹⁾	0,78 %	0,78 %	0,28 %	2,08 %
TCH/AHS7.95	(FER)	27 %	23 %	23 %	20 %	22 %
- Class I _b	(RBER)	0,85 %	2,3 %	2,3 %	2,1 %	2,3 %
- Class II	(RBER)	1,7 %	5,1 %	5,1 %	5,1 %	5,3 %
TCH/AHS7.95	(FER@+3dB)	14 %	6,7 %	6,7 %	6,5 %	6,7 %
- Class I _b	(RBER@+3dB)	0,49 %	1 %	1 %	0,98 %	1 %
- Class II	(RBER@+3dB)	1 %	3,1 %	3,1 %	3,1 %	3,2 %
TCH/AHS7.4	(FER)	26 %	18 %	18 %	16 %	18 %
- Class I _b	(RBER)	0,69 %	1,4 %	1,4 %	1,3 %	1,4 %
- Class II	(RBER)	1,9 %	5,5 %	5,5 %	5,4 %	5,6 %
TCH/AHS7.4	(FER@+3dB)	13 %	4,9 %	4,9 %	4,8 %	4,8 %
- Class I _b	(RBER@+3dB)	0,39 %	0,51 %	0,51 %	0,47 %	0,51 %
- Class II	(RBER@+3dB)	1,2 %	3,3 %	3,3 %	3,3 %	3,3 %
TCH/AHS6.7	(FER)	23 %	12 %	12 %	9,9 %	11 %
- Class I _b	(RBER)	0,71 %	1,2 %	1,2 %	1 %	1,2 %
- Class II	(RBER)	2,3 %	6 %	6 %	6 %	6,2 %
TCH/AHS6.7	(FER@+3dB)	11 %	2,5 %	2,5 %	2,5 %	2,3 %
- Class I _b	(RBER@+3dB)	0,39 %	0,38 %	0,38 %	0,37 %	0,39 %
- Class II	(RBER@+3dB)	1,4 %	3,5 %	3,5 %	3,5 %	3,6 %
TCH/AHS5.9	(FER)	21 %	7,7 %	7,7 %	6,4 %	7,1 %
- Class I _b	(RBER)	0,55 %	0,6 %	0,6 %	0,48 %	0,57 %
- Class II	(RBER)	2,6 %	6,4 %	6,4 %	6,3 %	6,5 %
TCH/AHS5.15	(FER)	17 %	3,8 %	3,8 %	3,1 %	3,3 %
- Class I _b	(RBER)	0,8 %	0,66 %	0,66 %	0,53 %	0,6 %
- Class II	(RBER)	3,1 %	6,8 %	6,8 %	6,6 %	6,9 %
TCH/AHS4.75	(FER)	15 %	2,1 %	2,1 %	1,8 %	1,8 %
- Class I _b	(RBER)	0,6 %	0,25 %	0,25 %	0,19 %	0,22 %
- Class II	(RBER)	3,6 %	7 %	7 %	6,8 %	7 %
TCH/AHS-INB	(FER)	2,8 % ⁽¹⁾	0,71 % ⁽¹⁾	0,71 % ⁽¹⁾	0,6 % ⁽¹⁾	0,7 % ⁽¹⁾
TCH/AHS-INB	(FER@-3dB)	5,9 % ⁽¹⁾	2,2 % ⁽¹⁾	2,2 % ⁽¹⁾	1,8 % ⁽¹⁾	2,2 % ⁽¹⁾
TCH/AHS	(EVSIDUR)	15 % ⁽¹⁾	3,1 % ⁽¹⁾	3,1 % ⁽¹⁾	3,5 % ⁽¹⁾	2,5 % ⁽¹⁾
TCH/AHS	(EVSIDUR@-3dB)	28 % ⁽¹⁾	15 % ⁽¹⁾	15 % ⁽¹⁾	14 % ⁽¹⁾	15 % ⁽¹⁾
TCH/AHS	(EVRFR)	11 % ⁽¹⁾	0,53 % ⁽¹⁾	0,53 % ⁽¹⁾	0,52 % ⁽¹⁾	0,51 % ⁽¹⁾
TCH/AHS	(EVRFR@-3dB)	22 % ⁽¹⁾	4,5 % ⁽¹⁾	4,5 % ⁽¹⁾	3,8 % ⁽¹⁾	4,4 % ⁽¹⁾
PDTCH/CS-1 to 4	(BLER)	10%	10%	10%	10%	10%
PDTCH/MCS-1 to 6	(BLER)	10%	10%	10%	10%	10%
PDTCH/MCS-7	(BLER)	10%	10%	10%	30%	10%
PDTCH/MCS-8	(BLER)	10%	30%	30%	-	30%
PDTCH/MCS-9	(BLER)	10%	30%	30%	-	30%
PRACH/11 bit	(BLER)	15%	15%	15%	15%	15%
PRACH/8 bit	(BLER)	15%	15%	15%	15%	15%
PACCH	(BLER)	10%	10%	10%	10%	10%

Table 20 c: GSM 400, GSM 900, GSM 850 and MXM 850 Multipath error performance limits at RX interference level offset 400 kHz

Channel Type	Error Measure	Error Ratios for the specified propagation conditions	
		TU50 (no SFH)	TI5 (no SFH)
FACCH/F	(FER)	17.1 %	17.1 %
TCH/FS	(FER)	10.2 α %	10.2 α %
- class Ib	(RBER)	0.72/ α %	0.72/ α %
- class II	(RBER)	8.8 %	8.8 %

NOTE: For GSM 400 the speeds shall be doubled (e.g. TU50 shall be TU100).

Table 20 d: DCS 1800, PCS 1900 and MXM 1900 Multipath error performance limits at RX interference level offset 400 kHz

Channel Type	Error Measure	Error Ratios for the specified propagation conditions	
		TU50 (no SFH)	TI5 (no SFH)
FACCH/F	(FER)	6.1 %	17.1 %
TCH/FS	(FER)	5.1 α %	10.2 α %
- class Ib	(RBER)	0.45/ α %	0.72/ α %
- class II	(RBER)	8.9 %	8.8 %

NOTE 2: For TU 6 (ideal FH), TU3 (ideal FH) and TU1.5 (ideal FH), sufficient decorrelation cannot readily be achieved between the channel propagation conditions for each frequency hopped on. The requirements in GSM 05.05 (EN 300 910) [22] for performance with TU1.5, TU3 or TU6(ideal FH) propagation condition cannot hence be tested and are thus absent in this test specification. They are inherently tested by TU50 (ideal FH) together with TU3 (no FH), TU 6 (no FH) or TU1.5 (no FH).

NOTE 3: In certain AMR channels, two requirements are given, one at the reference interference ratio and one at 3dB above or below the reference interference ratio. In these cases, only the requirement at 3dB above or below the reference interference ratio needs to be tested, except those marked by an (*), where only the requirement at the reference interference ratio needs to be tested.

7.5.5 Requirements Reference

GSM 05.05 (EN 300 910) [22] subclause 6.3.

7.6 Blocking Characteristics

7.6.1 Test Purpose

Blocking and spurious response rejection is a measure of the ability of a BSS receiver to receive a wanted GSM modulated signal in the presence of an interfering signal; the level of the interfering signal is higher for the test of blocking than for spurious response.

7.6.2 Test Case

The manufacturer shall declare any intermediate frequencies (IF1 to IFn) used within the receiver, and the frequency of the local oscillator applied to the first receiver mixer.

- 1) This measurement is carried out in three stages:
 - a) an optional preliminary test to identify frequencies of interfering signal which require more detailed investigation.
 - b) measurement of blocking performance.
 - c) measurement of spurious response performance; this test need only be performed at those frequencies of interfering signal at which the specification for blocking is not met.

- 2) The BSS shall be configured to operate as close to the centre of the operating receive band as is possible. If Slow frequency hopping is supported by the BSS, it shall be disabled during these measurements.
- 3) The two RF signals shall be fed into the receiver antenna connector of the BSS using a combining network. The wanted signal shall be at the operating frequency of the receiver, shall be modulated with normal GSM modulation, and shall be at a level as specified in table 21. The measurement is only performed under static propagation conditions.

If BSS supports both EGPRS and ECSD, it is not necessary to perform testing in both modes. If ECSD channel other than E-TCH/F43.2 NT is to be measured a wanted signal level 3 dB above the test signal level specified in subclause 7.3 shall be used, with the exception for GSM850, MXM850 and MXM 1900 normal BTSs, where a wanted signal 1 dB above the test signal level specified in subclause 7.3 shall be used. If TCH/FS is not supported, the highest supported of PDTCH/MCS-1 to MCS-4 shall be measured using a wanted signal level 3 dB above the test signal level specified in subclause 7.3, with the exception for GSM850, MXM850 and MXM 1900 normal BTSs, where a wanted signal 1 dB above the test signal level specified in subclause 7.3 shall be used. A MXM 1900 normal BTS may instead be tested to the requirements of a PCS 1900 normal BTS.

Table 21: Power level of wanted signal for test of Blocking Characteristics

BTS Type	Power level of Wanted Signal						
	TCH/ FS	E-TCH/ F43.2 NT	PDTCH/ MCS-5	PDTCH/ MCS-6	PDTCH/ MCS-7	PDTCH/ MCS-8	PDTCH/ MCS-9
GSM 400/ GSM900/DCS1800/PCS 1900 BTS	-101 dBm	-94 dBm	-98 dBm	-96.5 dBm	-93 dBm	-90 dBm	-88.5 dBm
GSM850/MXM850*/MXM 1900* BTS	-103 dBm	-96 dBm	-100 dBm	-98.5 dBm	-95 dBm	-92 dBm	-90.5 dBm
GSM900/GSM850/MXM 850* micro-BTS M1	-94 dBm	-87 dBm	-91 dBm	-89.5 dBm	-86 dBm	-83 dBm	-81.5 dBm
GSM900/GSM850/MXM 850* micro-BTS M2	-89 dBm	-82 dBm	-86 dBm	-84.5 dBm	-81 dBm	-78 dBm	-76.5 dBm
GSM900/GSM850/MXM 850* micro-BTS M3	-84 dBm	-77 dBm	-81 dBm	-79.5 dBm	-76 dBm	-73 dBm	-71.5 dBm
GSM900/GSM850/MXM 850* pico-BTS P1	-85 dBm	-78 dBm	-82 dBm	-80.5 dBm	-93 dBm	-74 dBm	-72.5 dBm
DCS1800/PCS 1900/ MXM 1900* micro-BTS M1	-99 dBm	-92 dBm	-96 dBm	-94.5 dBm	-91 dBm	-88 dBm	-86.5 dBm
DCS1800/PCS 1900/ MXM 1900* micro-BTS M2	-94 dBm	-87 dBm	-91 dBm	-89.5 dBm	-86 dBm	-83 dBm	-81.5 dBm
DCS1800/PCS 1900/ MXM 1900* micro-BTS M3	-89 dBm	-82 dBm	-86 dBm	-84.5 dBm	-81 dBm	-78 dBm	-76.5 dBm
DCS1800/PCS 1900/ MXM 1900* pico-BTS P1	-92 dBm	-85 dBm	-89 dBm	-87.5 dBm	-84 dBm	-81 dBm	-79.5 dBm

* NOTE: TCH/FS and E-TCH/F43.2 are not applicable for MXM850 and 1900.

PRELIMINARY TEST

- 4) This optional test may be performed to reduce the number of measurements required in step 8. If it is performed, this shall be at the frequencies specified below.
- 5) The test shall be performed for an interfering signal at all frequencies which are integer multiples of 200 kHz , and which fall within one or more of the frequency ranges listed below, but excluding frequencies which exceed 12.75 GHz or are less than 600 kHz from the wanted signal:
 - a) from
 - PGSM 900: 790 MHz to 1015 MHz inclusive.
 - EGSM 900: 780 MHz to 1015 MHz inclusive.
 - RGSM 900: 776 MHz to 1015 MHz inclusive.
 - DCS 1800: 1610 MHz to 1885 MHz inclusive.

PCS 1900 and MXM 1900: 1750 MHz to 2010 MHz inclusive.

GSM 850 and MXM 850: 724 MHz to 949 MHz inclusive.

GSM 450: 350 MHz to 558 MHz inclusive.

GSM 480: 378 MHz to 586 MHz inclusive.

- b) GSM 850, MXM 850, PGSM 900, EGSM900 and RGSM 900:

from $F_{lo} - (IF_1 + IF_2 + \dots + IF_n + 12.5 \text{ MHz})$ to

$F_{lo} + (IF_1 + IF_2 + \dots + IF_n + 12.5 \text{ MHz})$.

DCS 1800:

from $F_{lo} - (IF_1 + IF_2 + \dots + IF_n + 37.5 \text{ MHz})$ to

$F_{lo} + (IF_1 + IF_2 + \dots + IF_n + 37.5 \text{ MHz})$.

GSM 400:

from $F_{lo} - (IF_1 + IF_2 + \dots + IF_n + 3.6 \text{ MHz})$ to

$F_{lo} + (IF_1 + IF_2 + \dots + IF_n + 3.6 \text{ MHz})$.

PCS 1900 and MXM 1900:

from $F_{lo} - (IF_1 + IF_2 + \dots + IF_n + 30 \text{ MHz})$ to

$F_{lo} + (IF_1 + IF_2 + \dots + IF_n + 30 \text{ MHz})$.

- c) from $IF_1 - 400 \text{ kHz}$ to $IF_1 + 400 \text{ kHz}$.

- d) All of the ranges:

$mF_{lo} - IF_1 - 200 \text{ kHz}$ to $mF_{lo} - IF_1 + 200 \text{ kHz}$

and

$mF_{lo} + IF_1 - 200 \text{ kHz}$ to $mF_{lo} + IF_1 + 200 \text{ kHz}$

- e) All integer multiples of 10 MHz

Where: F_{lo} is the frequency of the local oscillator applied to the first receiver mixer.

$IF_1 \dots IF_n$ are the n intermediate frequencies.

m is all positive integers.

To reduce test time, a shortened test procedure according to annex A of the present document may be used, with an upper limit of measurement of 4 GHz.

- 6) The interfering signal shall be frequency modulated with a modulation frequency of 2 kHz and a peak deviation of +/- 100 kHz.

- 7) For separations between the wanted and interfering signals of:

PGSM 900, EGSM 900, RGSM 900, GSM 850 and MXM 850 : 45 MHz or less.

DCS 1800: 95 MHz or less,

PCS 1900 and MXM 1900: 80 MHz or less,

GSM 400: 10 MHz or less,

the level of the interfering signal at the receiver input shall be:

GSM 400, GSM 900, GSM 850 and MXM 850: -3 dBm.

DCS 1800, PCS 1900 and MXM 1900: -15 dBm.

For greater separations, the level of the interfering signal shall be +10 dBm.

The Residual Bit Error Ratio (RBER) for the TCH/FS channel using class II bits and the Block Error Ratio (BLER) for one supported PDTCH/MCS-x with lowest number x and 8PSK modulation ($x=5$, if the BSS supports all coding schemes) and/or E-TCH/F43,2 NT channel or BLER (or BER) for the highest supported data speed shall be measured and if TCH/FS is not supported the BLER for the tested PDTCH/MCS-1 to MCS-4. All frequencies at which the RBER exceeds 10 % and/or at which the BLER exceeds 25 % or the BER exceeds 0,25 % respectively shall be recorded for further study. A relaxed statistical significance may be used for this measurement, compared to that of step 9).

BLOCKING TEST

- 8) If the preliminary test has been performed, this test shall be performed at all frequencies which have been recorded at step 7. If the preliminary test has not been performed, this test shall be performed at all frequencies specified in step 5.

The interfering signal shall be unmodulated, and shall have a level at the receiver input as specified in table 22. For GSM 850 normal BTS, MXM 850 normal BTS and MXM 1900 normal BTS at frequency offsets ≥ 3000 kHz the interfering signal shall be GMSK modulated by any 148-bit sequence of the 511-bit pseudo random bit sequence, defined in CCITT Recommendation 0.153 fascicle IV.4.

- 9) The channels below shall, if supported, be measured. All frequencies at which the limit below is exceeded shall be recorded.

Channel: TCH/FS Limit: classII(RBER) = 2.0 %.

Channel: E-TCH/F43,2 NT
or for the highest supported data speed Limit: according to table 15

Channel: PDTCH/MCS-5
or, if not supported,
PDTCH/MCS-x with the
next higher supported number x Limit: according to table 15

Channel: PDTCH/MCS-1 to MCS-4
if TCH/FS is not supported Limit: according to table 15

For this test, in band frequencies are defined as follows:

PGSM900: 870 MHz to 925 MHz;

EGSM900: 860 MHz to 925 MHz;

RGSM900: 856 MHz to 921 MHz;

DCS1800: 1690 MHz to 1805 MHz.

GSM 450: 444.4 MHz to 460.4 MHz;

GSM 480: 472.8 MHz to 488.8 MHz;

GSM 850 and MXM 850: 804 MHz to 859 MHz;

PCS 1900 and MXM 1900: 1830 MHz to 1930 MHz;

NOTE: The methodology for the measurement of BER is described in annex A.

f_0 is the frequency of the wanted signal

Table 22: Level of interfering signal for blocking

Frequency band	GSM 400 and GSM900 (dBm)					DCS1800 and PCS 1900 (dBm)				
	BTS	micro and pico-BTS				BTS	micro and pico-BTS			
		M1	M2	M3	P1		M1	M2	M3	P1
in - band:										
$f_0 \pm 600$ kHz	-26	-31	-26	-21	-34	-35	-40	-35	-30	-41
$800 \text{ kHz} \leq f-f_0 < 1.6 \text{ MHz}$	-16	-21	-16	-11	-34	-25	-30	-25	-20	-41
$1.6 \text{ MHz} \leq f-f_0 < 3 \text{ MHz}$	-16	-21	-16	-11	-26	-25	-30	-25	-20	-31
$3 \text{ MHz} \leq f-f_0 $	-13	-21	-16	-11	-18	-25	-30	-25	-20	-23
out - of - band	8	8	8	8	8	0	0	0	0	0
Frequency band	GSM 850 and MXM 850 (dBm)					MXM 1900 (dBm)				
	BTS	micro and pico-BTS				BTS	micro and pico-BTS			
		M1	M2	M3	P1		M1	M2	M3	P1
in - band:										
$f_0 \pm 600$ kHz	-37	-31	-26	-21	-34	-43	-40	-35	-30	-41
$800 \text{ kHz} \leq f-f_0 < 1.6 \text{ MHz}$	-35	-21	-16	-11	-34	-38	-30	-25	-20	-41
$1.6 \text{ MHz} \leq f-f_0 < 3 \text{ MHz}$	-33	-21	-16	-11	-26	-33	-30	-25	-20	-31
$3 \text{ MHz} \leq f-f_0 $	-33	-21	-16	-11	-18	-33	-30	-25	-20	-23
out - of - band	8	8	8	8	8	0	0	0	0	0

NOTE: Micro and pico-BTS is not defined for GSM400.

For PGSM900 and EGSM900, the blocking level in the band 925 MHz to 935 MHz is relaxed to 0 dBm.

For RGSM900 at offsets $600 \text{ kHz} \leq |f-f_0| < 3 \text{ MHz}$, the blocking level in the band 876 MHz - 880 MHz shall be reduced by 5 dB.

Spurious response

10) This test shall be performed at all frequencies and channels which have been recorded at step 9. The interfering signal shall be unmodulated, and shall have a level of -43 dBm.

11) The RBER for TCH/FS channel using class II bits and BLER for one supported PDTCH/MCS-x with lowest number x and 8PSK modulation ($x=5$, if the BSS supports all coding schemes) and/or BLER for E-TCH/F43,2 NT or BLER (or BER) for the highest supported data speed and, if TCH/FS is not supported, the BLER for the tested PDTCH/MCS-1 to MCS-4 shall be measured.

7.6.3 Essential conformance

Test environment

Normal: One TRX shall be tested.

Conformance Requirement

For step 9) (blocking), the recorded frequencies for the channel type tested shall meet all of the following requirements:

a) For measurement frequencies which are:

GSM 900: 45 MHz or less from the wanted signal, the total number does not exceed six.

GSM 850 and MXM 850: in band frequencies, the total number does not exceed six.

DCS 1800: 95 MHz or less from the wanted signal, the total number does not exceed twelve.

PCS 1900 and MXM 1900: In band frequencies, the total number does not exceed twelve.

GSM 400: in band frequencies, the total number does not exceed three.

b) For measurement frequencies which are:

GSM 900: 45 MHz or less from the wanted signal, no more than three are consecutive.

GSM 850 and MXM 850: in band frequencies, no more than three are consecutive.

DCS 1800: 95 MHz or less from the wanted signal, no more than three are consecutive.

PCS 1900 and MXM 1900: In band frequencies, no more than three are consecutive.

c) For measurement frequencies which are:

GSM 900: more than 45 MHz from the wanted signal, the total number does not exceed twenty four.

GSM 850 and MXM 850: out band frequencies, the total number does not exceed twenty four.

DCS 1800: more than 95 MHz from the wanted signal, the total number does not exceed twenty four.

PCS 1900 and MXM 1900: out band frequencies, the total number does not exceed twenty four.

GSM 400: out band frequencies, the total number does not exceed twenty four.

d) For measurement frequencies which are:

GSM 900: more than 45 MHz below the wanted signal, no more than three are consecutive.

GSM 850 and MXM 850: out band frequencies below the wanted signal, no more than three are consecutive.

DCS 1800: more than 95 MHz below the wanted signal, no more than three are consecutive.

PCS 1900 and MXM 1900: out band frequencies below the wanted signal, no more than three are consecutive.

GSM 400: out band frequencies below the wanted signal, no more than three are consecutive.

For step 11) (spurious response), the limits below shall never be exceeded.

Channel: TCH/FS Limit: classII (RBER) = 2.0 %.

Channel: E-TCH/F43,2 NT
or the highest supported data speed Limit: according to table 15

Channel: PDTCH/MCS-5
or, if not supported,
PDTCH/MCS-x with the
next higher supported number x Limit: according to table 15.

Channel: PDTCH/MCS-1 to MCS-4
if TCH/FS is not supported Limit: according to table 15

7.6.4 Complete conformance

The requirements of essential conformance shall apply.

7.6.5 Requirements reference

GSM 05.05 (EN 300 910) [22] subclause 5.1.

7.7 Intermodulation characteristics

7.7.1 Test Purpose

This test measures the linearity of the receiver RF parts. It expresses the capability of the receiver to receive a wanted modulated signal without exceeding a given degradation due to the presence of two or more unwanted signals with a specific frequency relationship to the wanted signal frequency.

7.7.2 Test Case

If SFH is supported by the BSS, it shall be disabled during this measurement. The measurement is performed only under static conditions. The measurement shall be performed for the radio frequency channels B, M and T and for the supported channels in table 23. As a minimum, one time slot shall be tested on one TRX to be tested.

Three signals shall be applied to the receiver via a combining network. The powers of the signals are measured at the receiver antenna connector.

The wanted signal shall have a power level as defined in table 23.

The second signal is an interfering signal, GMSK modulated by a pseudo-random bit sequence, and shall be 1.6 MHz above the wanted signal frequency. During the useful part of the burst of the wanted signal, the modulation of this interfering signal shall be any 148-bits subsequent of the 511-bits sequence, defined in CCITT Recommendation O.153 fascicle IV.4., and the power shall be -43 dBm for GSM 400, GSM 900, GSM 850 and MXM 850 and -49 dBm for DCS1800, PCS 1900 and MXM 1900.

NOTE: This signal can be a continuous signal modulated by the 511-bits sequence.

The third signal is an interfering signal and shall be unmodulated. It shall be 800 kHz above the wanted signal frequency, and the power shall be -43 dBm for GSM 400, GSM 900, GSM 850 and MXM 850 and -49 dBm for DCS1800, PCS 1900 and MXM 1900.

The various signals are illustrated in figure 6.

If BSS supports both EGPRS and ECSD, it is not necessary to perform testing in both modes. If ECSD channel other than E-TCH/F43.2 NT is to be measured a wanted signal level 3 dB above the test signal level specified in subclause 7.3 shall be used. If TCH/FS is not supported, the highest supported of PDTCH/MCS-1 to MCS-4 shall be measured using a wanted signal level 3 dB above the test signal level specified in subclause 7.3.

Table 23: Wanted signal level for testing of Intermodulation Characteristics

BTS Type	Power level of Wanted Signal						
	TCH/FS	E-TCH/ F43.2 NT	PDTCH/ MCS-5	PDTCH/ MCS-6	PDTCH/ MCS-7	PDTCH/ MCS-8	PDTCH/ MCS-9
GSM 400/GSM850/GSM900/ DCS1800/PCS 1900/MXM 850/MXM 1900 BTS	-101 dBm	-94 dBm	-98 dBm	-96.5 dBm	-93 dBm	-90 dBm	-88.5 dBm
GSM900/GSM850/MXM 850 micro-BTS M1	-94 dBm	-87 dBm	-91 dBm	-89.5 dBm	-86 dBm	-83 dBm	-81.5 dBm
GSM900/GSM850/MXM 850 micro-BTS M2	-89 dBm	-82 dBm	-86 dBm	-84.5 dBm	-81 dBm	-78 dBm	-76.5 dBm
GSM900/GSM850/MXM 850 micro-BTS M3	-84 dBm	-77 dBm	-81 dBm	-79.5 dBm	-76 dBm	-73 dBm	-71.5 dBm
GSM900/GSM850/MXM 850 pico- BTS P1	-85 dBm	-78 dBm	-82 dBm	-80.5 dBm	-77 dBm	-74 dBm	-72.5 dBm
DCS1800/PCS 1900/ MXM 1900 micro-BTS M1	-99 dBm	-92 dBm	-96 dBm	-94.5 dBm	-91 dBm	-88 dBm	-86.5 dBm
DCS1800/PCS 1900/ MXM 1900 micro-BTS M2	-94 dBm	-87 dBm	-91 dBm	-89.5 dBm	-86 dBm	-83 dBm	-81.5 dBm
DCS1800/PCS 1900/ MXM 1900 micro-BTS M3	-89 dBm	-82 dBm	-86 dBm	-84.5 dBm	-81 dBm	-78 dBm	-76.5 dBm
DCS1800/PCS 1900/ MXM 1900 pico-BTS P1	-92 dBm	-85 dBm	-89 dBm	-87.5 dBm	-84 dBm	-81 dBm	-79.5 dBm

NOTE: TCH/FS and E-TCH/F43.2 are not applicable for MXM850 and 1900

The unprotected class II bits obtained from the BSS receiver after channel decoding and before any extrapolation shall be compared with the unprotected class II bits originating from the BSSTE.

The RBER of the TCH/FS class II bits and BLER of one supported PDTCH/MCS-x with lowest number x and 8PSK modulation (x=5, if the BSS supports all coding schemes) and E-TCH/F43,2 NT or BLER (or BER) of the highest supported data speed and, if TCH/FS is not supported, the BLER for the tested PDTCH/MCS-1 to MCS-4 shall be measured.

The measurement shall be repeated with the unwanted signal frequencies below the carrier frequency of the wanted signal.

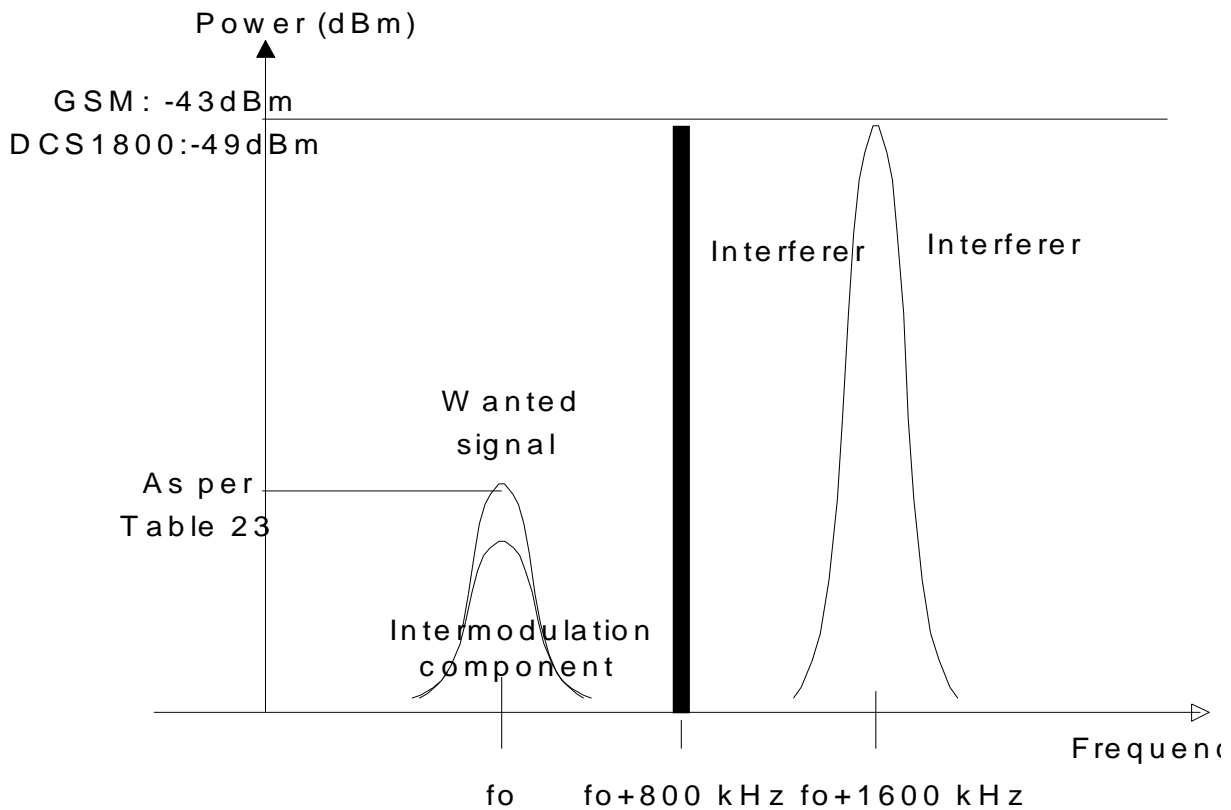

Figure 6: Example of RX intermodulation rejection

7.7.3 Essential conformance

Test Environment:

Normal: One TRX shall be tested.

Conformance Requirement

The RBER of TCH/FS Class II shall not exceed 2.0 %.

The BLER of E-TCH/F43.2 NT shall not exceed 10 % or BLER (or BER) of the highest supported data speed shall not exceed the values given in table 15..

The BLER of PDTCH/MCS-5 or, if not supported, of PDTCH/MCS-x with the next higher supported number x shall not exceed 10 %.

If TCH/FS is not supported the BLER of the tested PDTCH/MCS-1 to MCS-4 shall not exceed the values given in table 15.

NOTE: This conformance requirement together with conformance to subclause 7.5 (Reference Interference Level) is sufficient to demonstrate compliance to GSM 05.05 (EN 300 910) [22] subclause 5.3 for all logical channel types.

7.7.4 Complete conformance

Test Environment:

Test Environment: Each TRX shall be tested

Conformance Requirement

The RBER of TCH/FS Class II shall not exceed 2.0 %.

The BLER of E-TCH/F43.2 NT shall not exceed 10 % or BLER (or BER) of the highest supported data speed shall not exceed the values given in table 15.

The BLER of PDTCH/MCS-5
or, if not supported, of PDTCH/MCS-x
with the next higher supported number x shall not exceed 10 %.

If TCH/FS is not supported the BLER of the tested PDTCH/MCS-1 to MCS-4 shall not exceed the values given in table 15.

NOTE: This conformance requirement together with conformance to subclause 7.5 (Reference Interference Level) is sufficient to demonstrate compliance to GSM 05.05 (EN 300 910) [22] subclause 5.3 for all logical channel types.

7.7.5 Requirement Reference

GSM 05.05 (EN 300 910) [22] subclause 5.3

7.8 AM suppression

7.8.1 Test Purpose

AM suppression is a measure of the ability of a BSS receiver to receive a wanted GSM modulated signal without exceeding a given degradation due to the presence of an unwanted modulated signal.

7.8.2 Test Case

This test shall be performed at any one ARFCN on one TRX and on supported channels in table 24. If Slow Frequency Hopping (SFH) is supported by the BSS, it shall be disabled during this measurement. The measurement is performed only under static conditions.

The wanted signal shall have normal GSM modulation with a power level as defined in table 24.

If BSS supports both EGPRS and ECSD, it is not necessary to perform testing in both modes. If ECSD channel other than E-TCH/F43.2 NT is to be measured a wanted signal level 3 dB above the test signal level specified in subclause 7.3 shall be used. If TCH/FS is not supported, the highest supported of PDTCH/MCS-1 to MCS-4 shall be measured using a wanted signal level 3 dB above the test signal level specified in subclause 7.3.

Table 24: Test signal input level

BTS Type	Test signal Input Level to receiver TCH/FS	Power level of Wanted Signal					
		E-TCH/F4.3.2 NT	PDTCH/MCS-5	PDTCH/MCS-5	PDTCH/MCS-7	PDTCH/MCS-8	PDTCH/MCS-9
GSM400/GSM850/MXM 850/GSM900/DCS1800/PCS 1900/MXM 1900 BTS	-101 dBm	-94 dBm	-98 dBm	-96.5 dBm	-93 dBm	-90 dBm	-88.5 dBm
GSM900/GSM850/MXM 850 micro-BTS M1	-94 dBm	-87 dBm	-91 dBm	-89.5 dBm	-86 dBm	-83 dBm	-81.5 dBm
GSM900/GSM850/MXM 850 micro-BTS M2	-89 dBm	-82 dBm	-86 dBm	-84.5 dBm	-81 dBm	-78 dBm	-76.5 dBm
GSM900/GSM850/MXM 850 micro-BTS M3	-84 dBm	-77 dBm	-81 dBm	-79.5 dBm	-76 dBm	-73 dBm	-71.5 dBm
GSM900/GSM850/MXM 850 pico-BTS P1	-85 dBm	-78 dBm	-82 dBm	-80.5 dBm	-93 dBm	-74 dBm	-72.5 dBm
DCS1800/PCS1900/MXM 1900 micro-BTS M1	-99 dBm	-92 dBm	-96 dBm	-94.5 dBm	-91 dBm	-88 dBm	-86.5 dBm
DCS1800/PCS1900/MXM 1900 micro-BTS M2	-94 dBm	-87 dBm	-91 dBm	-89.5 dBm	-86 dBm	-83 dBm	-81.5 dBm
DCS1800/PCS1900/MXM 1900 micro-BTS M3	-89 dBm	-82 dBm	-86 dBm	-84.5 dBm	-81 dBm	-78 dBm	-76.5 dBm
DCS1800/PCS1900/MXM 1900 pico-BTS P1	-92 dBm	-85 dBm	-89 dBm	-87.5 dBm	-84 dBm	-81 dBm	-79.5 dBm

The interfering signal is GMSK modulated according to GSM characteristics (with or without a midamble) with a pseudo random bit sequence of at least 511 bits length.

NOTE 1: A 148-bit sequence of the 511-bit of a pseudo-random bit sequence as defined in CCITT Recommendation 0.153 fascile IV.4 is recommended.

Its frequency (f) shall be in the relevant receive band, at least 6 MHz separated from the ARFCN under test. Frequency f is an integer multiple of 200 kHz and at least 2 ARFCNs separated from any identified spurious response in step 9 of the test case in subclause 7.6.2.

The interferer shall have one timeslot active, meeting the power/time mask of figure 1. The transmitted bursts shall be synchronized to but delayed in time between 61 and 86 symbol periods relative to the bursts of the wanted signal. The mean level of the interferer over the useful part of the burst is defined in table 25.

Table 25: Interfering signal level

	BTS (dBm)	Micro-BTS			Pico-BTS
		M1 (dBm)	M2 (dBm)	M3 (dBm)	P1 (dBm)
GSM 400	-31	-	-	-	-
GSM 900	-31	-34	-29	-24	-21
GSM 850	-31	-34	-29	-24	-21
MXM 850	-33	-34	-29	-24	-21
DCS 1800	-35	-33	-28	-23	-26
PCS 1900	-35	-33	-28	-23	-26
MXM 1900	-35	-33	-28	-23	-26

The two input signals shall be connected to the receiver via a combining network. The referred power level for both signals shall be the power into the BSS RX antenna connector.

NOTE 2: When testing this requirement, a notch filter may be necessary to ensure that the co channel performance of the receiver is not compromised.

7.8.3 Essential conformance

Test Environment:

Normal.

Conformance Requirement

For a TCH/FS the RBER of class II, class Ib and the FER the error performance shall not exceed the values given in table 15.

For a E-TCH/F43,2 NT the BLER or for the highest supported data speed the BLER (or BER) performance shall not exceed the values given in table 15.

For a PDTCH/MCS-5 or, if not supported, for a PDTCH/MCS-x with the next higher supported number x the BLER performance shall not exceed the values given in table 15.

If TCH/FS is not supported the BLER of the tested PDTCH/MCS-1 to MCS-4 shall not exceed the values given in table 15.

7.8.4 Complete conformance

Test Environment:

Normal.

Conformance Requirement

The requirements of essential conformance shall apply.

7.8.5 Requirement Reference

GSM 05.05 [7] subclause 5.2.

7.9 Spurious emissions from the receiver antenna connector

7.9.1 Test Purpose

Spurious emissions are emissions at frequencies other than those of the BTS transmitter ARFCNs and adjacent frequencies. This test measures spurious emissions from the BTS receiver antenna connector.

7.9.2 Test Case

The transmitter shall be configured with one TRX active. It shall be allocated to RF Channel M and shall transmit at full power on all time slots.

For a BTS equipped with diversity, the requirements of this subclause apply to each receiver dedicated antenna connector.

For a BTS equipped with a duplexer or duplexers, the requirements of subclause 6.6 apply to any antenna connector which is a port for both transmitter(s) and receiver(s). Therefore, this test need not be performed on these ports.

The receiver antenna connector shall be connected to a spectrum analyser or selective voltmeter with the same characteristic impedance.

The detecting device shall be configured as defined in table 26. Peak hold shall be enabled, and the video bandwidth shall be approximately three times the resolution bandwidth. If this bandwidth is not available on the detecting device, it shall be the maximum available, and at least 1 MHz.

The power shall be measured over the frequency ranges specified in table 26.

7.9.3 Essential conformance

Test Environment:

Normal.

Table 26: measurement conditions for Conducted Emissions from the Receiver Antenna Connector

Frequency Band	Frequency offset	Resolution Bandwidth
100 kHz - 50 MHz		10 kHz
50 MHz - 500 MHz and outside the relevant transmit band	(offset from the edge of the relevant transmit band)	
	≥ 2 MHz	30 kHz
	≥ 5 MHz	100 kHz
500 MHz - 12.75 GHz and outside the relevant transmit band	(offset from the edge of the relevant transmit band)	
	≥ 2 MHz	30 kHz
	≥ 5 MHz	100 kHz
	≥ 10 MHz	300 kHz
	≥ 20 MHz	1 MHz
	≥ 30 MHz	3 MHz
Inside the relevant transmit band	(offset from the transmit carrier frequency)	
	≥ 1.8 MHz	30 kHz
	≥ 6 MHz	100 kHz

Conformance Requirement

The measured power shall not exceed:

-57 dBm for all frequencies up to 1 GHz.

-47 dBm for all frequencies above 1 GHz.

7.9.4 Complete conformance

The requirements of essential conformance shall apply.

7.9.5 Requirement Reference

GSM 05.05 (ETS 300 910) [7] subclause 5.4.

8 Radiated spurious emissions

8.1 Test Purpose

This test measures radiated spurious emissions from the BSS cabinet, including emissions due to the transmitters.

8.2 Test Case

- a) A test site fulfilling the requirements of ITU-R SM.329-7 [16] shall be used. The BTS shall be placed on a non-conducting support and shall be operated from a power source via an RF filter to avoid radiation from the power leads. The method of ITU-R SM.329-7 [16] shall be used, except in any case where it conflicts with the present document.

Radiation of any spurious components shall be detected by the test antenna and measuring receiver (e.g. a spectrum analyser). At each frequency at which a component is detected, the BSS shall be rotated and the height of the test antenna adjusted to obtain maximum response, and the effective radiated power of that component

determined by a substitution measurement. The measurement shall be repeated with the test antenna in the orthogonal polarization plane.

- b) The BTS shall be configured with one transmitter active, at its maximum output power on all time slots, on the specified ARFCNs. Slow frequency hopping shall be disabled.

NOTE: It may be necessary to take steps to ensure that emissions from other transmitters which are not active do not influence the results. This may be achieved by, for example, equipping the BTS with only one TRX or by muting the outputs of the transmitters to a greater degree than otherwise required in GSM 05.05 (ETS 300 910) [7].

- c) The measuring receiver shall be configured with a resolution bandwidth of 30 kHz and a video bandwidth of approximately three times this value. Peak hold shall be enabled. The received power shall be measured for frequencies with an offset of $1.8 \text{ MHz} \leq f < 6 \text{ MHz}$ from the carrier frequency, and which fall within the BTS relevant transmitter band.

At each frequency at which a component is detected, the maximum effective radiated power of that component shall be determined, as described in step a).

- d) The measuring receiver shall be configured with a resolution bandwidth of 100 kHz and a video bandwidth of approximately three times this value. Peak hold shall be enabled. The received power shall be measured for frequencies with an offset of $\geq 6 \text{ MHz}$ from the carrier frequency, and which fall within the BTS relevant transmitter band.

At each frequency at which a component is detected, the maximum effective radiated power of that component shall be determined, as described in step a).

- e) The BSS shall be configured with all transmitters active at their maximum output power on all time slots. If a TRX is designated as being a dedicated BCCH, it shall be allocated to RF channel M. All remaining TRXs shall be allocated in the following order; first to RF channel B, then to T, then distributed as evenly as possible throughout the BSS operating transmit band. Slow frequency hopping shall be disabled.

The measuring receiver shall be configured as defined in table 27. Peak hold shall be enabled, and the video bandwidth shall be approximately three times the resolution bandwidth. If this video bandwidth is not available on the measuring receiver, it shall be the maximum available, and at least 1 MHz. The received power shall be measured over the frequency range 30 MHz to 4 GHz, excluding the BTS relevant transmitter band.

Table 27: Spurious Emissions Measurements outside the transmit band

Frequency Band	Frequency offset	Resolution Bandwidth
30 MHz - 50 MHz		10 kHz
50 MHz - 500 MHz and outside the relevant transmit band	(offset from the edge of the relevant transmit band)	
	$\geq 2 \text{ MHz}$	30 kHz
	$\geq 5 \text{ MHz}$	100 kHz
500 MHz - 4 GHz and outside the relevant transmit band	(offset from the edge of the relevant transmit band)	
	$\geq 2 \text{ MHz}$	30 kHz
	$\geq 5 \text{ MHz}$	100 kHz
	$\geq 10 \text{ MHz}$	300 kHz
	$\geq 20 \text{ MHz}$	1 MHz
	$\geq 30 \text{ MHz}$	3 MHz

At each frequency at which a component is detected, the maximum effective radiated power of that component shall be determined, as described in step a).

8.3 Essential conformance

Test Environment:

Normal: Inside the relevant TX band: The test shall be performed with the TRX active on one ARFCN.

Outside the relevant TX band: The test shall be performed once.

Conformance Requirement

- a) The power measured at steps c) and d) shall not exceed -36 dBm.
- b) The power measured at step e) shall not exceed:
 - 36 dBm for frequencies up to 1 GHz.
 - 30 dBm for frequencies above 1 GHz.

8.4 Complete conformance

Test Environment:

Normal: Inside the relevant TX band: The test shall be performed three times with the TRX on one of the RF channels B, M, and T.

Outside the relevant TX band: The test shall be repeated until a measurement has been made with a TRX active on B, M and T

NOTE: For a BSS with 3 or more TRX, this requires only one measurement.

Conformance Requirement

- a) The power measured at steps c) and d) shall not exceed -36 dBm.
- b) The power measured at step e) shall not exceed:
 - 36 dBm for frequencies up to 1 GHz.
 - 30 dBm for frequencies above 1 GHz.

8.5 Requirement reference

GSM 05.05 (ETS 300 910) [7], subclause 4.3.

9 Radio link management

9.1 General

This clause describes the functions of the BSS which gain, maintain and release access to the radio link, the main objective being to provide a stable link for the higher protocol layers whilst hiding, as far as possible, the properties of the radiopath.

The detailed operation of these functions can be found in GSM 05.08 (EN 300 911) [23] and GSM 05.10 (EN 300 912) [24]. Some requirements are also found in GSM 05.02 (ETS 300 908) [19].

9.2 Synchronization

The BSS provides control information to the MS so that its transmissions arrive at the BSS within the allocated timeslot window and within the correct frequency tolerance.

The following requirements related to synchronization are not tested in this subclause:

- 1) Absolute Frequency Tolerance.
This is tested in subclause 6.2

2) Relative Frequency Tolerance

It is not possible to verify by testing that the RF-frequencies of all the TRXs in a BSS are all derived from the same frequency source. This may be confirmed by a manufacturers declaration

3) Synchronization of Data Clocks

It is not possible to verify by testing that the BSS clocking and timebase are derived from the same frequency source used for RF generation. This may be confirmed by a manufacturers declaration.

9.2.1 Timing Tolerance

9.2.1.1 Test purpose

Description

The timing tolerance is the relative time between bits of the same bit number (BN) in timeslots of the same timeslot number (TN) and frame number (FN) transmitted simultaneously from two TRXs in one cell of the BSS.

9.2.1.2 Test case

For a BTS supporting only one TRX, this test is not performed.

If SFH is supported by the BSS, it shall be disabled during this test.

The TRX supporting the BCCH shall be used as the reference to measure the relative timing of the transmissions from different TRXs. The results shall be analysed to ensure that the relative timing between any two TRXs which are transmitted simultaneously meets the requirement.

- a) The BSSTE shall establish a TCH using timeslot 0 in the TDMA frame structure (TN=0) on a specific frequency.
- b) The relative timing between this frequency and the BCCH frequency shall be measured on the training sequence (BN=74). TDMA-frames carrying Frequency Correction bursts or Synchronization bursts (T3=0,1,10,11,20,21,30,31,40,41) shall be excluded. This measurement shall be repeated for at least 100 bursts and the average shall be calculated and recorded.
- c) Step a) and b) shall be carried out with the TCH at the RF channels B, M and T, but avoiding the use of the same frequency as the BCCH.
- d) Step c) shall be carried out with the BCCH at the RF channels B, M and T, but avoiding the use of the same frequency as the TCH. The BCCH frequency shall be offset to the closest used RF channel in case they coincide.
- e) Step d) shall be repeated for all other TRXs in the BSS.
- f) The timing measurement shall be used to establish the maximum time difference between any two TRXs operating in one cell.

9.2.1.3 Essential conformance

This test need not to be performed.

9.2.1.4 Complete conformance

Test environment

Normal

Conformance requirement

The timing difference (as established in step f)) between any two TRXs shall be no greater than 1/4 symbol, measured at the BSS antenna connector.

9.2.1.5 Requirement reference

GSM 05.10 (EN 300 912) [24].

9.3 Frame structure

This section verifies that the BSS correctly generates TDMA frames and is capable of receiving transmitted bursts from Mobile Stations generated according to GSM recommendations.

The following requirements relating to frame structure are not tested in this subclause:

- 1) The delay of three timeslots between uplink and downlink is tested implicitly in subclause 9.6
- 2) The SACCH multiframe structure is implicitly tested in transmitter bit exactness test of subclause 6.1.

9.3.1 BCCH Multiframe

9.3.1.1 Test purpose

Description

The BCCH multiframe consists of 51 TDMA frames. There is one BCCH logical channel per BSS, which broadcasts general information. The frequency information is carried on the Frequency Correction Channel (FCCH) and the synchronization is transmitted on the Synchronization Channel (SCH).

9.3.1.2 Test case

- a) The BSS is configured with one TRX configured to support a BCCH. This is monitored in the BSSTE.
- b) The BSSTE shall search for the Frequency Correction burst.
- c) The BSSTE shall then search for the Synchronization burst.

9.3.1.3 Essential conformance

This test need not to be performed.

9.3.1.4 Complete conformance

Test environment

Normal

Conformance requirements

- 1) The BSSTE shall detect Frequency Correction bursts at $T3 = 0, 10, 20, 30$ and 40 and for no other $T3$ ($T3 = FN \bmod 51$, $FN =$ TDMA frame number).
- 2) The BSSTE shall also detect synchronization bursts at $T3 = 1, 11, 21, 31,$ and 41 and for no other $T3$.
- 3) At the SCH the BSSTE shall detect the BSIC set up for the BTS/BSS. This applies to any BSIC. The BSSTE shall also detect the correct RFN for the various $T3$ s.

9.3.1.5 Requirement reference

GSM 05.02 (ETS 300 908) [19] and GSM 05.10 (EN 300 912) [24].

9.3.2 TDMA-frame structure

9.3.2.1 Test purpose

Description

One TDMA frame consists of eight timeslots, with an average length of 156.25 symbol periods. This may be achieved by setting all timeslots to be 156.25 symbol periods or setting timeslots 0 and 4 to 157 symbol periods and the remaining (1, 2, 3, 5, 6, 7) to 156 symbol periods. This section will test that the BSS conforms to the declared frame structure.

9.3.2.2 Test case

The BSS shall be configured to generate multiframe with a combination of logical channels which gives a contiguous stream of normal or dummy bursts as defined in GSM 05.02 for more than one frame. If SFH is supported by the BSS, it shall be disabled during this measurement.

The slot lengths will be measured between the leading edge of the 14th symbol of the training sequence for that timeslot and the leading edge of the 14th symbol of the training sequence for the next timeslot.

9.3.2.3 Essential conformance

This test need not to be performed.

9.3.2.4 Complete conformance

Test environment

Normal

Conformance requirements

The measurements shall conform to the frame structure 1) or 2) as declared by the manufacturer.

- 1) The length of each timeslot shall be 156.25 symbol periods.
- 2) The length of timeslots 0 and 4 shall be 157 symbol periods and the length of the remaining (1, 2, 3, 5, 6, 7) shall be 156 symbol periods.

9.3.2.5 Requirement reference

GSM 05.02 (ETS 300 908) [19] and GSM 05.10 (EN 300 912) [24].

9.4 Radio link measurements

Whilst calls are being established and for their duration, the reception quality shall be continuously assessed in the BSS as criteria for handover and RF power control algorithms. The following criteria may be employed in order to perform this assessment:

- Signal strength (RXLEV)
- Signal quality (RXQUAL)
- MS-BSS distance
- Idle channel level.

The handover and power control strategies based on above parameters are up to the operator.

Some test cases in this subclause assume that the manufacturer provides appropriate logical or physical test access to perform all tests in this subclause. The manufacturer may also show compliance to the requirements by other means agreed between the parties.

9.4.1 Signal Strength

9.4.1.1 Measurement Accuracy

9.4.1.1.1 Test purpose

Description

RXLEV is the received signal level measured at the BSS receiver input averaged over a reporting period of length of 1 SACCH multiframe for a TCH and a SDCCH. This test verifies the range and the accuracy of this parameter.

9.4.1.1.2 Test case

If the manufacturer does provide appropriate logical or physical access to perform all the tests in this subclause, the tests shall be performed according to the test cases below.

The manufacturer shall declare how many TRXs the BSS supports:

- 1 TRX: The test shall be performed on B, M, T
- 2 TRX: Tests shall be performed on B,M,T and both TRXs shall be tested on at least one frequency.
- 3 TRX or more: Three TRXs shall be tested, one on B, one on M and one on T.

If Slow Frequency Hopping (SFH) is supported by BSS, it shall be disabled during this test.

- a) A test signal with normal GSM modulation originated from the BSSTE shall be applied to the BSS RX antenna connector on one timeslot.
- b) The test signal level shall be adjusted over the level range -110.5 dBm to -47.5 dBm in 1 dB steps and shall be kept stable for one reporting period.
- c) The RXLEV measurements shall be performed under static propagation conditions only.

9.4.1.1.3 Essential conformance

This test need not to be performed.

9.4.1.1.4 Complete conformance

Test environment

Normal and extreme temperature

Conformance requirements

- 1) The RXLEV value shall nominally be mapped to the received signal level as in Table 28

Table 28: Signal level estimation requirements

RXLEV	Power level:
0	less than -110 dBm
1	-110 dBm to -109 dBm
2	-109 dBm to -108 dBm
.	.
.	.
62	-49 dBm to -48 dBm
63	greater than -48 dBm

- 2) For any input signals of level x_1 and x_2 dBm within the range -110 dBm to -48 dBm, where x_1 is above reference sensitivity in table 30, $x_1 \leq x_2$ and $(x_2 - x_1) \leq 20$ dB, the corresponding measured values y_1 and y_2 shall be such that

$$(x_2 - x_1) - a \leq (y_2 - y_1) \leq (x_2 - x_1) + b$$

where a and b are the tolerances given in table 29 (see GSM 05.08, 8.1.2).

Table 29: Tolerance for relative accuracy of received signal strength measurement

Absolute level of lower level signal x_1 in dBm					Tolerance in dB	
nomal-BTS	DCS1800, PCS 1900 and MXM 1900 micro-BTS M1	GSM900, GSM 850 and MXM 850 Micro-BTS M1 and DCS1800, PCS 1900 and MXM 1900 Micro BTS M2	GSM900, GSM 850 and MXM 850 micro-BTS M2 and DCS1800, PCS1900 and MXM 1900 micro BTS M3	GSM900, GSM 850 and MXM 850 micro-BTS M3	a	b
≥ -90	≥ -88	≥ -83	≥ -78	≥ -73	2	2
≥ -103	≥ -101	≥ -96	≥ -91	≥ -86	3	2
< -103	< -101	< -96	< -91	< -86	4	2

NOTE: It is optional for the BSS to be able to report values below the reference sensitivity in table 30. These specifications apply to measurements which are on the same or on different RF channel.

- 3) The RMS received signal level at the receiver input shall be measured with an absolute accuracy of ± 4 dB from -110 dBm to -70 dBm under normal conditions and ± 6 dB over the full range of -110 dBm to -48 dBm under both normal and extreme temperature conditions.
- 3) If the received signal level falls below the reference sensitivity level for the type of BSS then the BSS shall report a level within a range allowing for the absolute accuracy given in conformance requirement c) above. In case the upper limit of this range is below the reference sensitivity level for the type of BSS, then the upper limit shall be considered as equal to the reference sensitivity level in table 30.

Table 30: Reference sensitivity level

BTS Type	Reference sensitivity level
GSM 400/GSM900/GSM 850/DCS1800/PCS 1900/MXM 850/MXM 1900 BTS	-104 dBm
GSM900/GSM 850/MXM 850 micro-BTS M1	-97 dBm
GSM900/GSM 850/MXM 850 micro-BTS M2	-92 dBm
GSM900/GSM 850/MXM 850 micro-BTS M3	-87 dBm
GSM900/GSM 850/MXM 850 pico-BTS P1	-88 dBm
DCS1800/PCS 1900/ MXM 1900 micro-BTS M1	-102 dBm
DCS1800/PCS 1900/ MXM 1900 micro-BTS M2	-97 dBm
DCS1800/PCS 1900/ MXM 1900 micro-BTS M3	-92 dBm
DCS1800/PCS 1900/ MXM 1900 pico-BTS P1	-95 dBm

9.4.1.2 Selectivity of signal strength measurements

9.4.1.2.1 Test purpose

Description

The received signal level (RXLEV) defined in 9.4.1.1 shall be able to discriminate between wanted signal in actual RF channel and interfering signal in adjacent ARFCN's. This selectivity characteristic is tested in this subclause.

9.4.1.2.2 Test case

If the manufacturer does provide appropriate logical or physical access to perform all the tests in this subclause, the tests shall be performed according to the test cases below.

If Slow Frequency Hopping (SFH) is supported by BSS, it shall be disabled during this test.

- a) As a minimum the test shall be performed on one TRX on one timeslot on one ARFCN.

b) One of the following test set-ups is used:

Test set-up A

Two input signals shall be connected to the receiver via a combining network. The test signal with normal GSM modulation shall have a power level 20 dB above the reference sensitivity level. The interfering signal shall be continuous, and have GSM modulation of pseudo-random bitstream without midamble

Test set-up B

The BSSTE shall establish a call set-up with the BSS and the RXLEV of the assigned channel shall be output from the BSS. The test signal with normal GSM modulation shall have a power level 20 dB above the reference sensitivity level.

c) Register the signal strength (RXLEV value) with only the wanted signal present at the RX input port.

d)

i) In test set-up A repeat the measurements with interferer input signal frequency offset and input level increased for each offset according to table 31a

Table 31a: Interferer offset and input level for RXLEV selectivity measurements

Interferer frequency offset	Relative input level
±200 kHz	9 dB
±400 kHz	41 dB

ii) In test set-up B repeat the measurements with the input signal at frequency offsets and signal levels according to table 31b.

Table 31b: Test signal offset and input level for RXLEV selectivity measurements

Frequency offset	Relative input level
200 kHz	16 dB
400 kHz	48 dB

d) The measurements shall be performed under static propagation conditions only.

9.4.1.2.3 Essential conformance

This test need not to be performed.

9.4.1.2.4 Complete conformance

Test environment

Normal

Conformance requirements

The reported RXLEV value shall in test case d) not exceed

- the value in test case c) with more than 1 for test set-up A.
- the value in test case c) for test set-up B.

9.4.1.2.5 Requirement reference

GSM 05.08 (EN 300 911) [23], subclause 8.1

9.4.2 Signal quality

9.4.2.1 Test purpose

Description

The received signal quality (RXQUAL) is specified in terms of bit error ratio (BER) before channel decoding averaged over a reporting period of length of 1 SACCH multiframe on a TCH or a SDCCH.

This test verifies the range and the accuracy of this parameter

9.4.2.2 Test case

If the manufacturer does provide appropriate logical or physical access to perform all the tests in this subclause, the tests shall be performed according to the test cases below.

As a minimum the test shall be performed on one TRX on one timeslot on one ARFCN

- a) One of the following test set-ups is used:

Test set-up A

If Slow Frequency Hopping (SFH) is supported by BSS, it shall be enabled during this test for hopping on different ARFCN for all timeslots over the specified hopping bandwidth specified by the manufacturer.

A call shall be set up between the BSSTE and the BSS.

Test set-up B

If Slow Frequency Hopping (SFH) is supported by BSS, it shall be disabled during this test.

Two input signals originated from the BSSTE shall be connected to the receiver via a combining network. The test signal with normal GSM modulation shall have a power level 20 dB above the reference sensitivity level. The interfering signal shall be a random, continuous, GSM modulated signal on the same ARFCN. For test in TU50, each signal shall be connected through a multipath fading simulator (MFS) as described in Annex B1.

- b) The signal level (set-up A) and the interferer signal level (set-up B) respectively shall be varied such that the BER on the wanted TCH measured at the logical interface point before channel decoding in the BSS are within all the BER ranges for the RXQUAL values in table 32a in turn.
- c) The logical reference point before channel decoding may be obtained by using the unprotected class II bits after channel decoding before any extrapolation is applied. Half-rate channels are measured by first establishing a full-rate channel, measuring the error ratio and then establishing a half-rate channel and checking the indicated error ratio.
- d) For each BER range, 1000 RXQUAL values shall be recorded, and with and without uplink DTX.
- e) The measurement shall be performed under the propagation conditions static and TU50.

9.4.2.3 Essential conformance

This test need not to be performed.

9.4.2.4 Complete conformance

Test environment

Normal

Conformance requirements

- 1) Table 32a shows the minimum probability that, when on a TCH, a specified value of RXQUAL shall be reported for a BER within the range as indicated in the table under static propagation conditions.

- 2) Table 32b shows the minimum probability that, when on a TCH, a specified value of RXQUAL or an adjacent value shall be reported for a BER within the range as indicated in the table under TU50 multipath propagation conditions.

Table 32a: Signal quality estimation requirements (static)

RXQUAL:	Range of actual BER:	Probability that correct RXQUAL band is reported shall exceed		
		Full rate:	Half rate	DTX:
0	< 0.10%	90 %	90 %	65 %
1	0.26% - 0.30 %	75 %	60 %	35 %
2	0.51% - 0.64 %	85 %	70 %	45 %
3	1.0% - 1.3 %	90 %	85 %	45 %
4	1.9% - 2.7 %	90 %	85 %	60 %
5	3.8% - 5.4 %	95 %	95 %	70 %
6	7.6% - 11.0%	95 %	95 %	80 %
7	> 15.0	95 %	95 %	85 %

NOTE 1: For the full-rate channel RXQUAL_FULL is based on 104 TDMA frames.

NOTE 2: For the half-rate channel RXQUAL_FULL is based on 52 TDMA frames.

NOTE 3: For the DTX-mode RXQUAL_SUB is based on 12 TDMA frames.

Table 32b: Signal quality estimation requirements (TU50)

Expected RXQUAL_FULL:	Range of actual BER:	Probability that expected RXQUAL_FULL is reported shall exceed
0/1	< 0.10%	85 %
1/0/2	0.26% - 0.30 %	85 %
2/1/3	0.51% - 0.64 %	85 %
3/2/4	1.0% - 1.3 %	90 %
4/3/5	1.9% - 2.7 %	90 %
5/4/6	3.8% - 5.4 %	90 %
6/5/7	7.6% - 11.0%	90 %
7/6	> 15.0	90 %

9.4.2.5 Requirement reference

GSM 05.08 (EN 300 911) [23], subclause 8.2

9.4.3 Idle channel signal level

9.4.3.1 Test purpose

Description

A procedure shall be implemented by which the BSS monitors the levels of interference on its idle traffic channels. These measurements are used for handover and channel allocation. This test verifies that BSS can measure signal strength including interference with appropriate accuracy on an idle channel. The measured signal strength of each idle channel is, after averaging, classified in one of five interference bands and reported to MSC on request in a RESOURCE INDICATION message. The report method, report period, averaging period and definition of interference band values are defined in a O&M message by the operator and the manufacturer. See GSM 08.08, subclauses 3.1.3, 3.2.18 and 3.2.2.48, and GSM 08.58 subclauses 8.6.1 and 9.3.21.

9.4.3.2 Test case

If the manufacturer does provide appropriate logical or physical access to perform all the tests in this subclause, the tests shall be performed according to the test cases below.

If the BSS is supporting SFH, this shall be disabled during this test.

The manufacturer shall declare how many TRXs the BSS supports:

- 1 TRX: The test shall be performed on B, M, T
 - 2 TRX: Tests shall be performed on B,M,T and both TRXs shall be tested on at least onefrequency.
 - 3 TRX or more: Three TRXs shall be tested, one on B, one on M and one on T.
- a) A GMSK signal modulated with pseudo-random bit sequences connected to BTS RX input.
 - b) The limits of the 5 possible interference bands, the reporting period and the averaging period are defined by the operator and the manufacturer.
 - c) The signal from the BSSTE shall be adjusted over the level range -110.5 dBm to -47.5 dBm in 1 dB steps.
 - d) The measured signal strength is recorded for each signal level.
 - e) The interference level expressed as one of the 5 possible interference level bands, included in the RF_RES_IND message, shall be stored for each idle channel.

9.4.3.3 Essential conformance

This test need not be performed.

9.4.3.4 Complete conformance

Test environment

Normal

Conformance requirement

- 1) The accuracy requirements 1)-4)for the measured signal strength in subclause 9.4.1.1.4 apply.
- 2) The measured signal levels shall be mapped into the interference level band defined in b) and the corresponding band value included in the RF_RES_IND message for each idle channel.

9.4.3.5 Requirement reference

GSM 05.08 (EN 300 911) [23] Annex A 3.1 e).

9.5 Adaptive frame alignment

9.5.1 Test purpose

Description

Adaptive frame alignment is the mechanism by which the timeslots transmitted by the MS are initially and dynamically adjusted in time so that the received timeslots in the BSS always fall within the correct time window. This mechanism is controlled by the BSS.

The adaptive frame alignment mechanism is needed since the guard time between timeslots in the timeslot structure is not long enough to cope with MS-BSS propagation delays due to absolute distance. The MS timing is initially adjusted (initial alignment) when accessing the BSS, and is then continuously adjusted for relative distance variations during the call (dynamic alignment).

The BSS continuously monitors the delay in the transmission from the MS relative to the expected signal from an MS at zero range. This is required to give Timing Advance information to the MS. This information of the delay (up to 63 or 219 symbols) may also be used as a criteria for initiating handover at the cell boundary (MAX_MS_RANGE).

This subclause also tests the MS-BSS distance assessment.

9.5.2 Test case

If Slow Frequency Hopping (SFH) is supported by the BSS, it shall be disabled during this measurement. The tests shall be performed at least on one TRX for the radio frequency channels B, M and T and for timeslots 0 (initial alignment) and 1 or other timeslot except 0 (dynamic alignment) respectively on the same TRX.

The tested timeslots shall be exposed to static propagation conditions.

For each MS emulated the signal strength shall be according to table 33. If other TCH than TCH/FS is to be used in the test, a input signal 3 dB below the test signal input level specified in subclause 7.3 shall be used.

Table 33: Input signal strength at test of adaptive time alignment

BTS Type	Input signal strength
GSM 400/GSM900/GSM 850/DCS1800/PCS 1900/MXM 850/MXM 1900 BTS	-107 dBm
GSM900/GSM 850/MXM 850 micro-BTS M1	-100 dBm
GSM900/GSM 850/MXM 850 micro-BTS M2	-95 dBm
GSM900/GSM 850/MXM 850 micro-BTS M3	-90 dBm
DCS1800/PCS 1900/ MXM 1900 micro-BTS M1	-105 dBm
DCS1800/PCS 1900/ MXM 1900 micro-BTS M2	-100 dBm
DCS1800/PCS 1900/ MXM 1900 micro-BTS M3	-95 dBm

To avoid a radio link time-out during the tests, the BSSTE may generate an uplink SACCH with a non-limiting signal strength including MEASUREMENT REPORT messages signalling high RXLEV and low RXQUAL values. This applies to the emulated MS when configured with an SACCH, i.e. configured with a dedicated channel.

- a) Initial alignment: Random access bursts shall be input on the RACH (timeslot 0) as often as possible using different random references .
- b) The emulated round-trip propagation delay shall be 3 different values corresponding to TA-values from 0 to 63 (0 to 219 for GSM 400) in turn (low, medium and high).
- c) The Timing Advance (TA) value reported to the MS shall be monitored and compared.
- d) Dynamic alignment: A TCH/FS (other TCH can be used if TCH/FS is not supported) shall be established between the BSSTE and the BSS.
- e) The emulated round-trip propagation delay of the MS shall vary corresponding to the vehicle speed of 500 km/h, starting from maximum MS-BSS distance moving close to the BSS and back.

The Timing Advance (TA) value signalled to the Mobile Station shall be monitored and compared.

9.5.3 Essential conformance

This test need not be performed

9.5.4 Complete conformance

Test environment

Normal

Conformance requirements

The difference DELTA between the emulated round-trip propagation delay and the signalled TA-value for the applicable timeslot shall be evaluated in symbols rounded to the nearest integer for at least 1000 pairs of timeslots, and shall have the following properties:

- 1) For initial alignment, the mean of DELTA shall be not greater 0 +/- 1 symbol.
- 2) For dynamic alignment, the mean of DELTA shall be not greater than 0 +/- 5/4 symbol.

3) Under all conditions the standard deviation of DELTA shall be less than 1 symbol.

NOTE: +/- 1 symbol tolerance is +/- 1/2 symbol for assessment error and +/- 1/2 symbol for quantization error.

NOTE: Requirement 1 above may need 1 additional symbol of tolerance if the BSS has an RX-TX delay tolerance of +/- 1 symbol.

The maximum allowed TA-value signalled to the MS is 63 symbols except for GSM 400 where it is 219 symbols.

9.5.5 Requirement reference

GSM 05.10 (EN 300 912) [24]

Annex A (informative): Testing of statistical parameters

When measuring statistical parameters like Bit Error Rates (BERs) or Frame Erasure Rates (FERs), the statistical nature of the error events may result in a natural variance in the observed test results. This variance will depend on the number of events observed. Consequently, due to such statistical limitations with the aim to reduce the test time to a minimum, some overall requirements should be met, indicating a certain confidence in the observed results.

Defining a "good" BSS as a BSS which on a long term basis (tested over an infinite time) meets the system requirement for an individual test, and a "bad" BSS as a BSS which on a long term basis fails the system requirement for an individual test, the overall requirements are the following:

- 1) The probability of passing a "good" BSS should be as high as possible.
- 2) The probability of passing a "bad" BSS should be as low as possible.

A.1 General theoretical methodology

Statistical parameters are measured as a number of error events M within a set of observed events (or samples) N , and the ratio M/N is used as the estimated value. This estimate has a given uncertainty due to the limited statistical material, i.e. the number of samples N . The general methodology to ensure correct PASS / FAIL decisions is outlined in the following.

Given a random variable X_i output from a random process indicating error/no error, the probability of an error is p and consequently, the probability of no error is $1-p$. The expected value $E(X_i)$ and variance $\text{Var}(X_i)$ as given in (Eq 1), according to the binomial probability distribution.

$$E(X_i) = p \quad (\text{Eq 1a})$$

$$\text{Var}(X_i) = p - p^2 \quad (\text{Eq 1b})$$

If the number of samples of the event is N , the average X of the random variables X_i is of interest, which has the expected value $E(X)$ and variance $\text{Var}(X)$ given in (Eq 2), assuming that the random variables X_i are independent.

$$E(X) = p \quad (\text{Eq 2a})$$

$$\text{Var}(X) = (p - p^2) / N \quad (\text{Eq 2b})$$

Assuming that the error probability p is small, the formula can be simplified as in (Eq 3).

$$E(X) = p \quad (\text{Eq 3a})$$

$$\text{Var}(X) = p / N \quad (\text{Eq 3b})$$

Furthermore, if the number of samples N is great, the probability density of X may be assumed to be Gaussian and the confidence intervals needed can easily be found.

Assuming that a "good" BSS has the real performance P_g when measured over an infinite time and that a "bad" BSS has the corresponding performance P_b , the relationships to the system requirement P_s are the following:

$$P_g \leq P_s \quad (\text{Eq 4a})$$

$$P_b > P_s \quad (\text{Eq 4b})$$

Irrespective of the values of P_g and P_b , the aim would ideally be to guarantee that the probabilities of passing a "good" BSS, $P(\text{PASS}|P_g)$ and the probability of failing a "bad" BSS, $P(\text{FAIL}|P_b)$ are as high as possible. Given a certain P_g and a certain P_b , this can be done by increasing the number of samples N until the distributions around P_g and P_b are "narrow" enough, i.e. the variances are sufficiently reduced, so that there is sufficient space in between for a test requirement P_t with the required confidence. The principle is illustrated in figure A.1 with $P_g=P_s$.

In practice, the above ideal approach can not be used since when P_g or P_b get very close to P_s , the needed number of samples to reduce the variances would be infinite. However, what can be done is to represent P_g by the worst-case P_s and to have a certain confidence of failing a BSS which is a given amount worse than P_s , i.e. with a fixed P_b . This will, however, give less confidence in failing a "bad" BSS which has a performance closer to P_s . This is the exact principle illustrated in figure A.1.

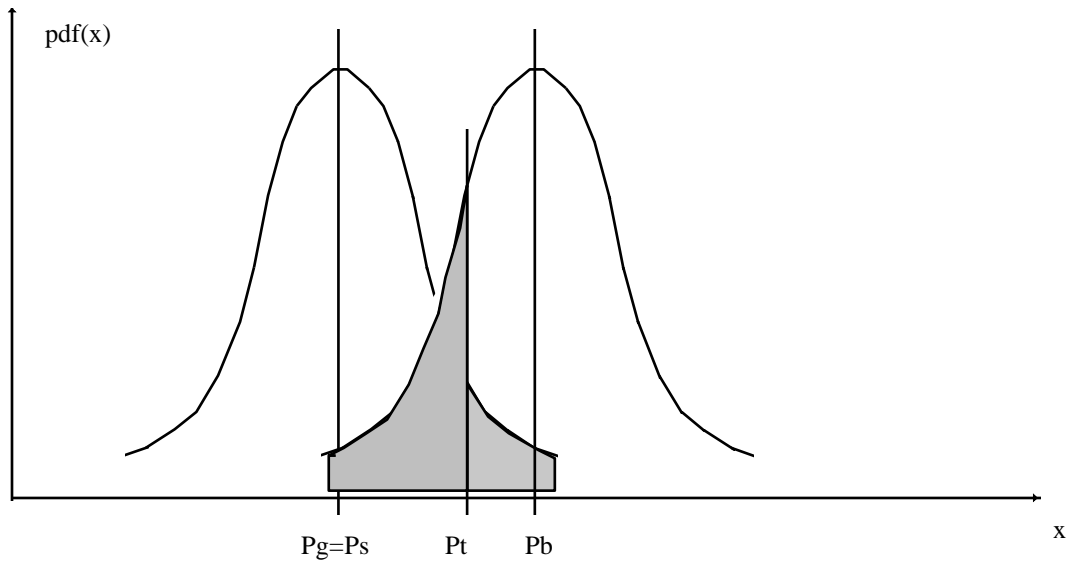

P_s = system requirement

P_t = test requirement

P_g = real performance of a "good" BTS

P_b = real performance of a "bad" BTS

Figure A.1: Statistical testing

The test requirement P_t will then be as in equation (Eq 5) for the overall requirements depending on P_s and P_b , and on the needed number of samples N :

$$P_t = P_s + G (P_s/N)^{1/2} \tag{Eq 5a}$$

$$P_t = P_b - B (P_b/N)^{1/2} \tag{Eq 5b}$$

G and B are the ordinates (in fact the inverse Gaussian Q-function) giving the normalized Gaussian distribution confidence intervals required for passing a "good" BSS and failing a "bad" BSS, respectively.

Finally, if the ratio P_b/P_s is fixed, the number of samples is given by the following equations (Eq 6).

$$N = \frac{(G + \sqrt{K} B)^2}{(K - 1)^2 P_s} \tag{Eq 6a}$$

$$P_b = K P_s \tag{Eq 6b}$$

A.2 Detailed theoretical methodology

The total number of statistical tests indicated in annex C (excluding blocking, intermodulation etc.) are :

GSM 900:95

DCS 1800: 96

and the rules of the tests are as follows:

- in order to pass a BSS it should pass all tests.
- a single test which fails should be repeated once. If the BSS fails a 2nd time, the BSS has failed.

This means that the overall probability of passing a good BSS through all the tests is lower than for the individual tests.

Taking into account the total of

GSM 900:95 tests,

DCS 1800: 96 tests,

assuming that the outcomes of the tests are independent, and requiring that the total probability of passing a "good" BSS should be equal to the total probability of failing a "bad" BSS, the overall confidence requirements in this annex should be as follows on a test by test basis:

$$P(\text{PASS}|P_s) \geq 99.9 \% \quad (\text{i.e. } G = 3.09)$$

$$P(\text{FAIL}|P_b) \geq 95.0 \% \quad (\text{i.e. } B = 1.65)$$

With the above assumptions, the total probabilities of passing a "good" BSS and failing a "bad" BSS will be around 91.0 %.

NOTE 1: If for some reason not all tests are carried out, then the probability of failing a "bad" BSS, $P(\text{FAIL}|P_b)$, should be increased accordingly.

Since the test requirement P_t will lie somewhere in between the system requirement P_s and P_b , and that an uncertainty in test equipment resulting from imperfections in the randomness of pseudo-random generators etc. can be expected to give errors of the order of $\pm 5\%$, the ratio P_b/P_s should be 2.

Under idealized assumptions, the resulting minimum number of samples needed to meet the overall confidence requirements is indicated as a function of the system requirement P_s using (Eq 6) in table A.1.

The ratio of the test requirement P_t to the system requirement P_s will in this case be:

$$P_t = 1.57 P_s$$

NOTE 2: It is possible to reduce the needed number of samples. In that case the ratio P_b/P_s should be increased, or the confidence levels should be reduced, see equation (Eq.5). It is preferable to keep the confidence and to increase P_b/P_s . However, the accepted error rate P_t , and P_b , should not deviate too much from the system requirement P_s , especially for high P_s . In order to have meaningful requirements it may even be desirable to reduce P_b/P_s for high P_s .

Table A.1: Minimum number of samples for statistical testing

Error rate P_s	Minimum number of samples
1.0 E-1	300
1.0 E-2	3 000
1.0 E-3	30 000
1.0 E-4	300 000
1.0 E-5	3 000 000

A.3 Limitations and corrections to the theoretical methodology

The idealized assumptions resulting in table A.1 are:

- 1) All random variables X_i (error events) are assumed to be independent.
- 2) The observed random variable X is assumed to have a Gaussian distribution.
- 3) All random variables X_i (error events) are assumed to be outputs of stationary random processes with identical distributions.
- 4) The system requirement P_s is assumed to be sufficiently small.

A.3.1 Independent errors

The assumption that all error events are independent does not strictly hold. The fact that error events are mutually dependent, would increase the variance of the observed random variable X , and consequently, the number of samples needed for the confidence required should be multiplied by some factor indicating the number of error events which on average are completely correlated.

- For FERs the events occur so seldom that the events may be regarded as independent (factor of 1), the exception being TCH/FS, FACCH, TCH/A xS which should have a factor of 2.
- Since a convolutional decoder on average will produce burst errors of the order of the constraint length, BERs and RBERs should have a factor of 5.

Generally, the situation will be such that a "good" BSS will have a performance P_g which is better than P_s . Consequently, the number of samples found in all cases by (Eq 6) should be multiplied by an additional factor of 2.

A.3.2 Gaussian distribution

The assumption of a Gaussian distribution for the observed random variable X should hold in most cases due to the high number of samples used.

A.3.3 Stationary random processes

The assumption that the error events are outputs of stationary random processes with identical distributions holds generally for static propagation conditions. However, for multipath propagation conditions this is not true. On the other hand, the multipath propagation condition may be assumed to be stationary for short periods of time. Taking into account the worst-case situation of flat fading where the distance between fades is a wavelength, the characteristics of the propagation condition may be assumed to change e.g. 10 times per wavelength and to be short term stationary in between. This means that all the different random variables X_i (error events) have a different p_i and consequently different $E(X_i)$ and $\text{Var}(X_i)$. Since all p_i are unknown and only the random variable X , which is the average of all X_i , is observed against a system requirement P_s , the statistical parameters of (Eq 7) result in the case of multipath propagation conditions assuming that all p_i are independent.

$$E(X) = \frac{1}{N} \sum_{i=1}^N p_i = p \quad (\text{Eq 7a})$$

$$\text{Var}(X) = \frac{p}{N} - \frac{1}{N^2} \sum_{i=1}^N p_i^2 \quad (\text{Eq 7b})$$

Also in this case the variance can (and should) be simplified to p/N if all p_i are small. However, in this case the second term of (Eq 7b) is dominated by the greatest p_i and the simplification is less valid than for static propagation conditions. Nevertheless, the needed number of samples given by (Eq 6) is conservative because the variance would ideally be lower. On the other hand, if the fact that the different p_i are likely to be correlated with positive correlation is taken into account, $\text{Var}(X)$ will increase and the simplification to p/N might be adequate.

Since under multipath conditions the observed random variable X results from an average of a set of random processes, we should ensure that the average takes into account a sufficient number of processes to get an overall stationary process. Requiring an average over 1000 wavelengths (or 10 000 processes if the multipath propagation condition is updated every 10th of a wavelength), the resulting observation period needed is indicated in table A.2 if the logical channel in question occupies the basic physical channel all the time. The percentage of the time "on the air" for the logical channel should also be taken into account and consequently, the observation period indicated in table A.2 will be increased by an inverse frame filling factor.

Table A.2: Required observation periods under multipath

Multipath condition	Time per Wavelength	Required observation period
TU1.5	800 ms	800s
TU3	400 ms	400 s
TU50	24 ms	24 s
HT100	12 ms	12 s
RA250	5 ms	5 s
RA130	9.6 ms	9.6 s
T15	240 ms	240 s

A.3.4 Low error ratios

The assumption that the system requirement P_s is sufficiently small holds generally. However, when reaching a high P_s , e.g. around 10^{-1} , the approximation in (Eq 3) is not strictly accurate. However, using the correct variance would decrease the needed number of samples, so the assumptions give conservative results.

A.3.5 Total corrections

As a conclusion, the various limitations of the assumptions discussed in the above subclauses all lead to different increases of the needed number of samples to obtain the required confidence. The different increases should all be taken into account by taking the highest increase, and calculated number of samples are indicated in annex C. The overall confidence resulting is possibly slightly lower than 99.9 % and 95.0 %, but it should be quite close. Considering as well that the different tests are likely to be correlated, will make the overall probabilities of passing a "good" BSS and failing a "bad" BSS higher than indicated.

NOTE: The worst case in terms of test time it is the static sensitivity performance for the SACCH/T, giving 7,9 hours. On average, the test times are around 35,6 min and range from 5,0s.

A.4 Alternative experimental methodology

The alternative experimental methodology indicated in this subclause could be used to verify, or possibly modify, the needed number of samples indicated in the previous subclauses. This would be most useful in the case of multipath propagation conditions where the statistics are very complicated and can not easily fit into simple formulae.

The approach is indicated in the following, and should be carried out once and for all for each multipath propagation condition, for each logical channel and for each type of error event according to subclause A.5 to assess the needed number of samples. Then, it can be used ever after for any BSS.

- 1) Record the number of error events for N_p periods of N_s samples (events) under static propagation conditions for an average system requirement P_s and for a given type of error event on a given logical channel.
- 2) Estimate the error ratio $ER_i = M_i/N_s$ for each of the N_p periods.

- 3) Consider the average ER of all ER_i and estimate the expected value $E(ER)$ and the variance $Var(ER)$:

$$m = E(ER) = \frac{1}{N_p} \sum_{i=1}^{N_p} ER_i \quad (\text{Eq 8a})$$

$$s^2 = Var(ER) = \frac{1}{N_p} \sum_{i=1}^{N_p} ER_i^2 - m^2 \quad (\text{Eq 8b})$$

The test requirement P_t is found as follows:

$$P_t = P_s + G s \quad (\text{Eq 9a})$$

and

$$P_t = K P_s - B s \quad (\text{Eq 9b})$$

- 4) The test shall be repeated with a different number of samples N_s until the test requirement P_t differs with less than $\pm 5\%$ in (Eq 9a) and (Eq 9b).

The initial number of samples N_s should be as indicated in annex 3 and the number of tests N_p should be 100.

The average system requirement P_s should be around 1.0×10^{-2} . It can then be assumed that the needed number of samples N_s is inversely proportional to P_s .

A.5 Detailed definition of error events

- 1) Frame Erasure Ratio (FER):

The frame is defined as erased if the error detection functions in accordance with GSM 05.03 (ETS 300 909) [5] indicate an error. For full-rate speech this is the result of a 3 bit Cyclic Redundancy Check (CRC), for signalling the result of the FIRE code or other block code used. For data traffic the FER is not defined.

NOTE: For full-rate speech it would ideally be better if the Bad Frame Indication (BFI) is used as frame erasure indication since this is what is directly related to the subjective quality of the perceived speech. For the moment no requirements relate to the BFI, however, it is very difficult to assess what is subjectively the optimum combination of Frame Erasure Ratio (FER) and Residual Bit Error Ratio (RBER). This should therefore be avoided and it is essential that the BFI is optimized towards the ideal frame erasures independent of the processing to obtain it, and that the BFI is not biased towards BFI=0 or BFI=1.

- 2) Residual Bit Error Ratio (RBER):

The RBER is defined as the residual Bit Error Ratio (BER) in frames which have not been declared as erased.

- 3) Bit Error Ratio (BER):

The BER is the overall Bit Error Ratio (BER) independent of frame erasures or when erased frames are not defined.

Annex B (informative): Description of special test equipment

B.1 Base Station System Test Equipment (BSSTE)

The BSSTE is a functional tool for the purpose of acceptance testing of GSM Base Station Systems. The BSSTE functionally carries out all tests described in this equipment specification.

B.1.1 Fading and multipath propagation simulator

A Multipath Fading Simulator (MFS) is needed to perform some of the tests on the receiver, to simulate realistic wideband multipath propagation over the mobile radio channel (i.e. the path between the base station and mobile station antennas). The following set of standard multipath propagation conditions, as specified by COST 207 and described in GSM 05.05 (ETS 300 910) [7], are required:

- 1) Typical Urban terrain (TU)
- 2) Rural terrain (RA)
- 3) Hilly terrain (HT)

In addition the MFS needs to a special multipath profile, designed to verify the equalization capabilities of the receiver:

- 4) Equalizer (EQU)

The multipath profiles are used for a range of nominal vehicle speeds

GSM 900: From 3 km/h to 250 km/h. The speeds 3, 50, 100 and 250 km/h are used in particular.

DCS 1800: From 1.5 km/h to 130 km/h. The speeds 1.5, 50, 100 and 130 km/h are used in particular.

The details of the multipath conditions and the corresponding requirements on the MFS itself are to be found in GSM 11.10 (Mobile Station Conformity Specification).

The MFS is functionally a part of the BSSTE as described in this annex, but may physically be a separate piece of equipment.

B.2 Measurement set ups for TX intermodulation

The following test set-ups are examples for possible solutions for the measurements according to subclauses 6.7 and 6.8. These measurements are very difficult to perform due to the extreme requirements of the dynamic range. To get reproducible measurements precautions should be taken, so that non-linearity's in the test set-up do not influence the measurement results.

NOTE 1: Care should be exercised in creating the test set-up and good quality cables and connectors should be used. Cables should be physically secured and not disturbed unless necessary.

NOTE 2: Connectors should be free of ferro-magnetic substances. Different surface materials on both connectors as well as the applied torque of the connection have an influence on the intermod-performance.

NOTE 3: Power attenuators normally have an insufficient intermod-performance at high power input levels. Therefore it is recommended to use long cables for attenuation where high power is applied.

B.2.1 Test set-up for Intermodulation Attenuation (6.7.)

It is necessary to use different set-ups for the measurement of IM-products in the RX band and outside the RX band.

B.2.1.1 RX-Band

A recommended test set-up for the intermodulation attenuation in the receive band is illustrated in figure B.1. A directional coupler is used with the measurement performed on the primary line connector. Sufficient filtering is provided by the duplexer so that the spectrum analyser operates in its linear range. The injected signal is amplified and filtered to provide sufficient isolation to inhibit self generated intermodulation products in the test set-up.

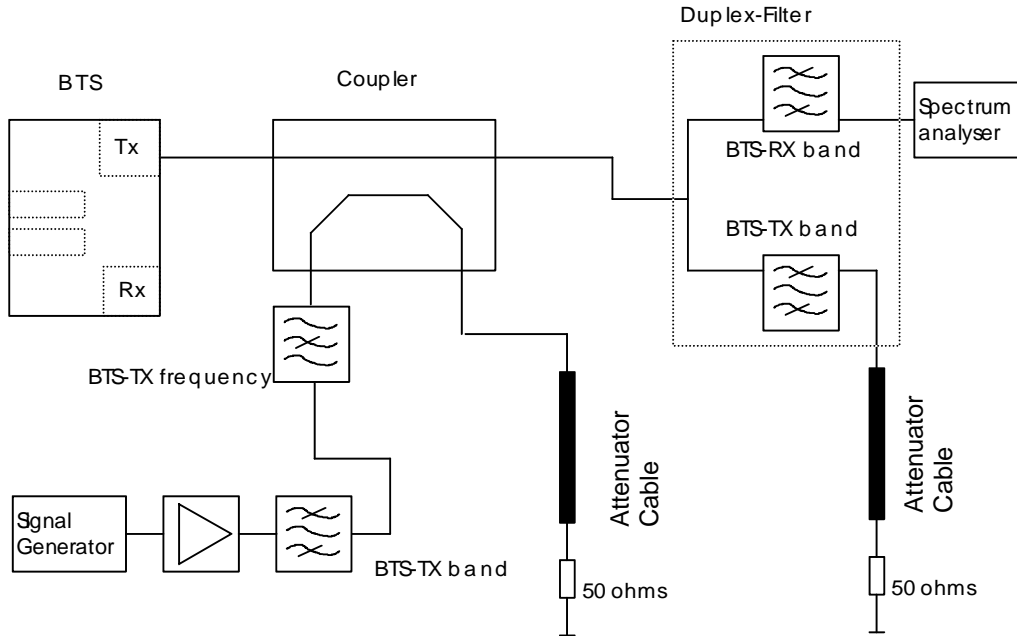

Figure B.1: Test set-up for Intermodulation Attenuation (6.7.) RX-Band

B.2.1.2 Outside RX Band

A recommended test set-up for the intermodulation attenuation outside the receive band is illustrated in figure B.2. The coupling device shall be specified to operate over sufficient bandwidth to comply with the measurement requirements.

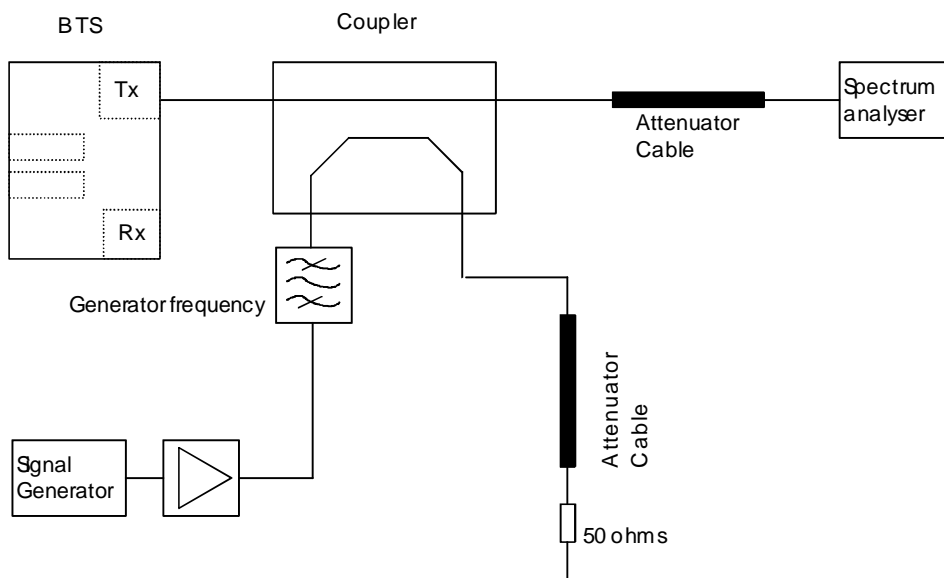

Figure B.2: Test set-up for Intermodulation Attenuation (6.7.) outside RX-Band

B.2.2 Test set-up for Intra BSS Intermodulation Attenuation (6.8.)

It is necessary to use different set-ups for the measurement of IM-products in the RX band and in the TX band.

B.2.2.1 RX-Band

A recommended test set-up for the intra base station intermodulation attenuation in the receive band is illustrated in figure B.3.

The stop band attenuation of the duplex filter has to be high enough to guarantee that the spectrum analyser is working in its linear range.

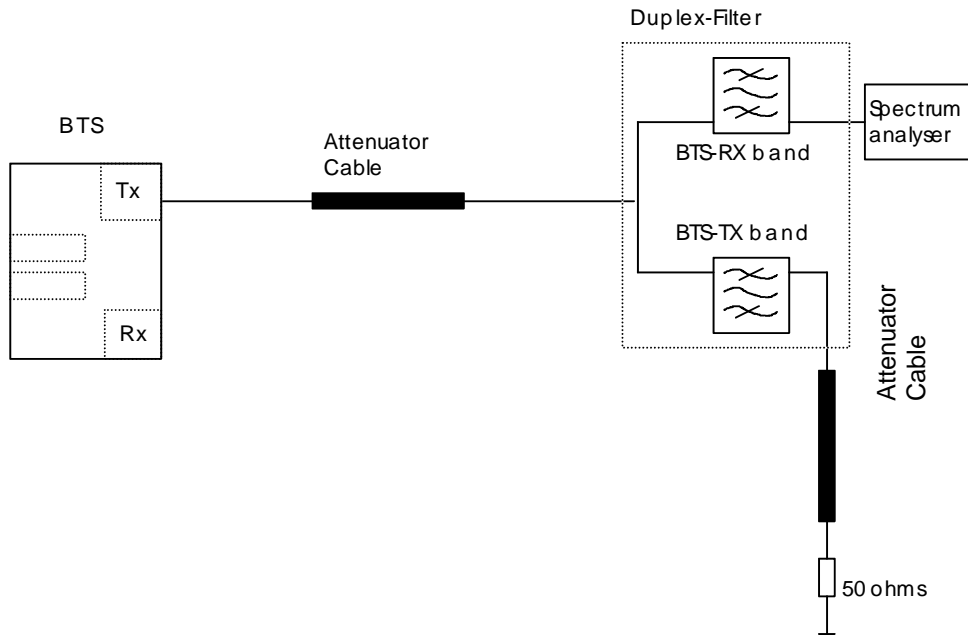

Figure B.3: Test set-up for Intra Base station Intermodulation Attenuation (6.8.) RX-Band

B.2.2.2 TX-Band

A recommended test set-up for the intra base station intermodulation attenuation inside the transmit band is illustrated in figure B.4. To decrease the dynamic range requirement of the spectrum analyser external filters should be used.

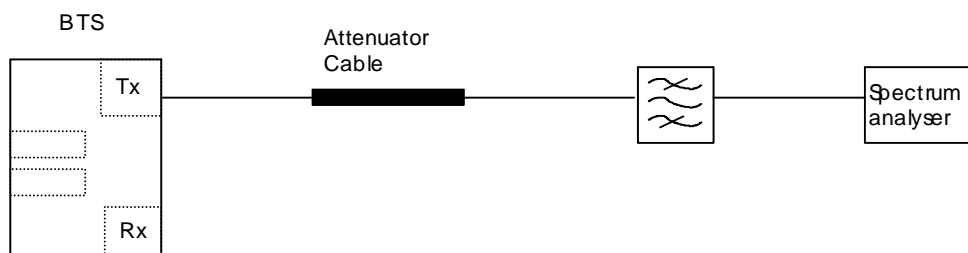

Figure B.4: Test set-up for Intra Base station Intermodulation Attenuation (6.8.) TX-Band

Annex C (informative): Number of samples needed for statistical testing

C.1 GSM 900; Number of samples for testing

GSM 900 SDCCH

(FER: 4.25 events/s, frame filling = 4/51)

Prop. cond.	Error rate	Stat. sign.	Indep. samples	Station. proc.	Samples:	Time: (s)
static	FER=0.10%	30 000	2	-	60 000	14 117.6
TU50	FER=13%	231	2	1 301	1 301	306.1
TU50 (SFH)	FER=8%	375	2	1 301	1 301	306.1
RA250	FER=8.0%	375	2	271	750	176.5
HT100	FER=12%	250	2	651	651	153.2
TU3	FER=22%	136	2	21 675	21 675	5 100.0
TU3(SFH)	FER=9%	333	2	21 675	21 675	5 100.0
TU50 (SFH)	FER=9%	333	2	1 301	1 301	306.1
TI5	FER=13%	231	2	13 005	13 005	3 060.0

GSM 900 RACH

(FER: 217 events/s, frame filling = 1)

Prop. cond.	Error rate	Stat. sign.	Indep. samples	Station. proc.	Samples:	Time: (s)
static	FER=0.50%	6 000	2	-	12 000	55.3
TU50	FER=13%	231	2	5 208	5 208	24.0
RA250	FER=12%	250	2	1 085	1 085	5.0
HT100	FER=13%	231	2	2 604	2 604	12.0
TU3	FER=15%	200	2	86 800	86 800	400.0
TU3(SFH)	FER=15%	200	2	86 800	86 800	400.0
TU50	FER=16%	188	2	5 208	5 208	24.0
RA250	FER=13%	231	2	1 085	1 085	5.0
TU50(SFH)	FER=13%	231	2	5 208	5 208	24.0
TI5	FER=13%	231	2	52 080	52 080	240.0
TU50(SFH)	FER=16%	188	2	5 208	5 208	24.0
TI5	FER=16%	188	2	52 080	52 080	240.0

GSM 900 SACCH/T

(FER: 2.1 events/s, frame filling = 1/26)

Prop. cond.	Error rate	Stat. sign.	Indep. samples	Station. proc.	Samples:	Time: (s)
static	FER=0.10%	30 000	2	-	60 000	28 571.4
TU50	FER=13%	231	2	1 311	1 311	624.3
TU50(SFH)	FER=8%	375	2	1 311	1311	624.3
RA250	FER=8.0%	375	2	273	750	357.1
HT100	FER=12%	250	2	656	656	312.4
TU3	FER=22%	136	2	21 840	21 840	10 400.0
TU3(SFH)	FER=9%	333	2	21 840	21 840	10 400.0
TU50(SFH)	FER=9%	333	2	1 311	1 311	624.3
TI5	FER=13%	231	2	13 104	13 104	6 240.0

GSM 900 SACCH/C

(FER: 2.13 events/s, frame filling = 4/102)

Prop. cond.	Error rate	Stat. sign.	Indep. samples	Station. proc.	Samples:	Time: (s)
static	FER=0.10%	30 000	2	-	60 000	28 169.0
TU50	FER=13%	231	2	1 304	1 304	612.2
TU50(SFH)	FER=8%	375	2	1 304	1 304	612.2
RA250	FER=8.0%	375	2	272	750	352.1
HT100	FER=12%	250	2	652	652	306.1
TU3	FER=22%	136	2	21 726	21 726	10 200.0
TU3(SFH)	FER=9%	333	2	21 726	21 726	10 200.0
TU50(SFH)	FER=9%	333	2	1 304	1 304	612.2
TI5	FER=13%	231	2	26 071	26 071	12 240

GSM 900 FACCH/F

(FER: 50 events/s, frame filling = 24/26)

Prop. cond.	Error rate	Stat. sign.	Indep. samples	Station. proc.	Samples:	Time: (s)
static	FER=0.10%	30 000	4	-	120 000	2 400.0
TU50	FER=8%	375	4	1 300	1 500	30.0
TU50(SFH)	FER=3.8%	789	4	1 300	3 156	63.1
RA250	FER=3.4%	882	4	271	3 528	70.6
HT100	FER=6.3%	476	4	650	1 904	38.1
TU3	FER=22%	136	4	21 667	21 667	433.3
TU3(SFH)	FER=3.4%	882	4	21 667	21 667	433.3
TU50	FER=9.5%	316	4	1 300	1 300	26.0
TU50(SFH)	FER=3.4%	882	4	1 300	1 300	70.6
RA250	FER=3.5%	857	4	271	3 428	68.6
TI5	FER=8.0%	375	4	13 000	13 000	260.0
TI5	FER=9.5%	316	4	13 000	13 000	260.0
TU50	FER=17.1%	176	4	1300	1300	26.0
TI5	FER=17.1%	176	4	13 000	13 000	260.0

GSM 900 FACCH/H

(FER: 25 events/s, frame filling = 12/26)

Prop. cond.	Error rate	Stat. sign.	Indep. samples	Station. proc.	Samples:	Time: (s)
static	FER=0.10%	30 000	4	-	120 000	4 800.0
TU50	FER=6.9%	435	4	1 300	1 740	69.6
RA250	FER=5.7%	526	4	271	2 104	84.2
HT100	FER=10%	300	4	650	1 200	48.0
TU3	FER=22%	136	4	21 667	21 667	866.7
TU3(SFH)	FER=6.7%	448	4	21 667	21 667	866.7
TU50	FER=6.7%	448	4	1 300	1 792	71.7
TU50(SFH)	FER=6.9%	435	4	1 300	1 740	69.6
TI5	FER=6.9%	435	4	13 000	13 000	520.0
TU50(SFH)	FER=6.7%	448	4	1 300	1 792	71.7
TI5	FER=6.7%	448	4	13 000	13 000	520.0

GSM 900 TCH/F9.6

(BER: 12000 events/s, frame filling = 24/26)

Prop. cond.	Error rate	Stat. sign.	Indep. samples	Station. proc.	Samples:	Time: (s)
static	BER=1.0E-5	3000 000	10	-	30000 000	2 500.0
TU50	BER=0.50%	6 000	10	312 000	312 000	26.0
TU50(SFH)	BER=0.4%	7 500	10	312 000	312 000	26.0
RA250	BER=0.10%	30 000	10	65 000	300 000	25.0
HT100	BER=0.70%	4 286	10	156 000	156 000	13.0
TU3	BER=8.0%	375	10	5200 000	5200 000	433.3
TU3(SFH)	BER=0.30%	10 000	10	5200 000	5200 000	433.3
TU50	BER=0.80%	3750	10	312 000	312 000	26.0
TU50(SFH)	BER=0.3%	10 000	10	312 000	312 000	26.0
RA250	BER=0.20%	15 000	10	65 000	150 000	12.5
TI5	BER=0.5%	6 000	10	3 120 000	3 120 000	260.0
TI5	BER=0.8%	3 750	10	3 120 000	3 120 000	260.0

GSM 900 TCH/H4.8

(BER: 6000 events/s, frame filling = 12/26)

Prop. cond.	Error rate	Stat. sign.	Indep. samples	Station. proc.	Samples:	Time: (s)
static	BER=1.0E-5	3000 000	10	-	30000 000	5 000.0
TU50	BER=0.50%	6 000	10	312 000	312 000	52.0
TU50(SFH)	BER=0.4%	7500	10	312 000	312 000	52.0
RA250	BER=0.10%	30 000	10	65 000	300 000	50.0
HT100	BER=0.70%	4 286	10	156 000	156 000	26.0
TU3	BER=8.0%	375	10	5200 000	5200 000	866.7
TU3(SFH)	BER=0.30%	10 000	10	5200 000	5200 000	866.7
TU50	BER=0.8%	3 750	10	312 000	312 000	52.0
TU50(SFH)	BER=0.3%	10 000	10	312 000	312 000	52.0
RA250	BER=0.20%	15 000	10	65 000	150 000	25.0
TI5	BER=0.5%	6 000	10	3 120 000	3 120 000	520.0
TI5	BER=0.8%	3 750	10	3 120 000	3 120 000	520.0

GSM 900 TCH/F4.8

(BER: 6000 events/s, frame filling = 24/26)

Prop. cond.	Error rate	Stat. sign.	Indep. samples	Station. proc.	Samples:	Time: (s)
TU50	BER=1.0E-4	300 000	10	156 000	3000 000	500.0
RA250	BER=1.0E-4	300 000	10	32 500	3000 000	500.0
HT100	BER=1.0E-4	300 000	10	78 000	3000 000	500.0
TU3	BER=3.0%	1 000	10	2600 000	2600 000	433.3
TU3(SFH)	BER=1.0E-4	300 000	10	2600 000	3000 000	500.0
TU50(SFH)	BER=1.0E-4	300 000	10	1 560 000	3 000 000	260.0
TI5	BER=1.0E-4	300 000	10	1 560 000	3 000 000	260.0

GSM 900 TCH/F2.4

(BER: 3600 events/s, frame filling = 24/26)

Prop. cond.	Error rate	Stat. sign.	Indep. samples	Station. proc.	Samples:	Time: (s)
TU50	BER=2.0E-04	1500 00	10	93 600	15000 00	416.7
RA250	BER=1.0E-5	3 000 000	10	3 900	30 000 000	8 333.3
HT100	BER=1.0E-5	3 000 000	10	46 800	30 000 000	8 333.3
TU3	BER=3.0%	1 000	10	1 560 000	1 560 000	433.3
TU3(SFH)	BER=1.0E-5	3 000 000	10	1 560 000	30 000 000	8 333.3
TU50	BER=3.0E-5	1 000 000	10	93 600	10 000 000	2 777.8
TU50(SFH)	BER=1E-05	3 000 000	10	93 600	30 000 000	8 333.3
TI5	BER=2.0E-4	150 000	10	936 000	1 500 000	416.7
TU50	BER=1.0E-4	300 000	10	93 600	3 000 000	833.3
TI5	BER=1.0E-4	300 000	10	936 000	3 000 000	833.3

GSM 900 TCH/H2.4

(BER: 3600 events/s, frame filling = 12/26)

Prop. cond.	Error rate	Stat. sign.	Indep. samples	Station. proc.	Samples:	Time: (s)
TU50	BER=1.0E-4	300 000	10	187 200	3 000 000	833.3
RA250	BER=1.0E-4	300 000	10	39 000	3 000 000	833.3
HT100	BER=1.0E-4	300 000	10	93 600	3 000 000	833.3
TU3	BER=4.0%	750	10	3 120 000	3 120 000	866.7
TU3(SFH)	BER=1.0E-4	300 000	10	3 120 000	3 120 000	866.7
TU50	BER=2.0E-4	150 000	10	187 200	1 500 000	416.7
TU50(SFH)	BER=1.0E-04	300 000	10	187 200	3 000 000	833.3
TI5	BER=1.0E-4	300 000	10	1 872 000	3 000 000	833.3
TI5	BER=2.0E-4	150 000	10	1 872 000	1 872 000	520.0

GSM 900 TCH/FS

(FER: 50 events/s, RBER class Ib: 6600 events/s, RBER class II: 3900 events/s, frame filling = 24/26)

Prop. cond.	Error rate	Stat. sign.	Indep. samples	Station. proc.	Samples:	Time: (s)
static	FER=0.10%	30 000	4	-	120 000	2 400.0
Ib	RBER=0.40%	7 500	10	-	75 000	11.4
II	RBER=2.0%	1 500	10	-	15 000	3.8
TU50	FER=6.0%	500	4	1 300	2 000	40.0
Ib	RBER=0.40%	7 500	10	171 600	171 600	26.0
II	RBER=8.0%	375	10	101 400	101 400	26.0
TU50(SFH)	FER=3%	1 000	4	1 300	4 000	80.0
Ib	RBER=0.3%	10 000	10	171 600	171 600	26.0
II	RBER=8%	375	10	101 400	101 400	26.0
RA250	FER=2.0%	1 500	4	271	6 000	120.0
Ib	RBER=0.20%	15 000	10	35 750	150 000	22.7
II	RBER=7.0%	429	10	21 125	21 125	5.4
HT100	FER=7.0%	429	4	650	1 716	34.3
Ib	RBER=0.50%	6 000	10	85 800	85 800	13.0
II	RBER=9.0%	333	10	50 700	50 700	13.0
TU3	FER=21%	143	4	21 667	21 667	433.3
Ib	RBER=2.0%	1 500	10	2860 000	2 860 000	433.3
II	RBER=4.0%	750	10	1690 000	1 690 000	433.3
TU3(SFH)	FER=3.0%	1 000	4	21 667	21 667	433.3
Ib	RBER=0.20%	15 000	10	2860 000	2 860 000	433.3
II	RBER=8.0%	375	10	1690 000	1 690 000	433.3
TU50(SFH)	FER=3%	1 000	4	1 300	4 000	80.0
Ib	RBER=0.2%	15 000	10	171 600	171 600	26.0
II	RBER=8%	375	10	101 400	101 400	26.0
RA250	FER=3.0%	1 000	4	271	4 000	80.0
Ib	RBER=0.20%	15 000	10	35 750	150 000	22.7
II	RBER=8.0%	375	10	21 125	21 125	5.4
static II	RBER=1.0E-4	300 000	10	-	3 000 000	769.2
EQU50 II	RBER=3.0%	1 000	10	101 400	101 400	26.0
static	FER=5%	600	4	-	2400	48.0
TI5	FER=6%	500	4	13 000	13 000	260.0
Ib	RBER=0.4%	7500	10	1 716 000	1 716 000	260.0
II	RBER=8.0%	375	10	1 014 000	1 014 000	260.0
TU50	FER=10.2%	294	4	1 300	1 300	26.0
Ib	RBER=0.72%	4167	10	171 600	171 600	26.0
II	RBER=8.8%	341	10	101 400	101 400	26.0
TI5	FER=10.2%	294	4	13 000	1 300	26.0
Ib	RBER=0.72%	4167	10	1 716 000	1 716 000	260.0
II	RBER=8.8%	341	10	1 014 000	1 014 000	260.0

GSM 900 TCH/F14.4

(BER: 14500 events/s, frame filling = 24/26)

Prop. cond.	Error rate	Stat. Sign.	Indep. samples	Station. proc.	Samples:	Time: (s)
static	BER=1.0E-5	3 000 000	10	-	30 000 000	2 069.0
TU50	BER=2.5%	1 200	10	377 000	377 000	26.0
TU50(SFH)	BER=2.0%	1 500	10	377 000	377 000	26.0
RA250	BER=2.0%	1 500	10	78 542	78 542	5.4
HT100	BER=5.0%	600	10	188 500	188 500	13.0
TU3	BER=10.0%	300	10	6 283 333	6 283 333	433.3
TU3(SFH)	BER=3.0%	1000	10	6 283 333	6 283 333	433.3
TU50(SFH)	BER=3.0%	1 000	10	377 000	377 000	26.0
RA250	BER=3.0%	1 000	10	78 542	78 542	5.4
TU50	BER=4.5%	667	10	377 000	377 000	26.0
TI5	BER=2.5%	1 200	10	3 770 000	3 770 000	260.0
TI5	BER=4.5%	667	10	3 770 000	3 770 000	260.0

GSM 900 TCH/HS

(FER: 50 events/s, RBER class Ib: 3650 events/s, RBER class II: 850 events/s, frame filling = 12/26)

Prop. cond.	Error rate	Stat. sign.	Indep. samples	Station. proc.	Samples:	Time: (s)
static (FER)	0.025%	120 000	4	-	480 000	9 600.0
Ib	0.001%	3 000 000	10	-	30 000 000	8 219.2
II	0.720%	4 167	10	-	41 667	49.0
TU50 (FER)	4.10%	732	4	2 600	2 927	58.5
Ib	0.36%	8 333	10	189 800	189 800	52.0
II	6.90%	435	10	44 200	44 200	52.0
RA250 (FER)	4.10%	732	4	542	2 927	58.5
Ib	0.28%	10 714	10	39 542	107 143	29.4
II	6.80%	441	10	9 208	9 208	10.8
HT100 (FER)	4.50%	667	4	1 300	2 667	53.3
Ib	0.56%	5 357	10	94 900	94 900	26.0
II	7.60%	395	10	22 100	22 100	26.0
TU3 (FER)	19.10%	157	4	43 333	43 333	866.7
Ib	0.52%	5 769	10	3 163 333	3 163 333	866.7
II	2.80%	1 071	10	736 667	736 667	866.7
TU50 (FER)	5.00%	600	4	2 600	2 600	52.0
Ib	0.29%	10 345	10	189 800	189 800	52.0
II	7.10%	423	10	44 200	44 200	52.0
RA250 (FER)	4.70%	638	4	542	2 553	51.1
Ib	0.21%	14 286	10	39 542	142 857	39.1
II	7.00%	429	10	9 208	9 208	10.8
TU50 (SFH) FER	4.10%	732	4	2 600	2 927	58.5
Ib	0.36%	8 333	10	189 800	189 800	52.0
II	6.90%	435	10	44 200	44 200	52.0
T15 (FER)	4.1%	732	4	26 000	26 000	520.0
Ib	0.36%	8 333	10	1 898 000	1 898 000	520.0
II	6.9%	435	10	442 000	442 000	520.0
TU50 (SFH) FER	5.0%	600	4	2 600	2 600	52.0
Ib	0.29%	10 345	10	189 800	189 800	52.0
II	7.1%	423	10	44 200	44 200	52.0
T15 (FER)	5.0%	600	4	26 000	26 000	520.0
Ib	0.29%	10 345	10	1 898 000	1 898 000	520.0
II	7.1%	423	10	442 000	442 000	520.0

To reduce the testing time on static FER and RBER class Ib the factor $k = P_b/P_s$ may be increased from $k = 2$ to $k > 2$ thus resulting in reasonable reductions of the test times, see table below. If this test fails, the test may be repeated with the number of samples given in the table above.

Prop. cond.	$k = P_b/P_s$	Stat. sign.	Indep. samples	Samples:	Time: (s)	Probability of no error (1 - p)
static (FER)	2.5	60 000	4	240 000	4800 (1h20')	6.8 %
Ib	2.5	1 500 000	10	15 000 000	4110 (1h08')	6.8 %
static (FER)	3.0	40 000	4	160 000	2880 (48')	15.8 %
Ib	3.0	1 000 000	10	10 000 000	2466 (41')	15.8 %

GSM 900 TCH/EFS

(FER: 50 events/s, RBER class Ib: 6600 events/s, RBER class II: 3900 events/s, frame filling = 24/26)

Prop. cond.	Error rate	Stat. sign.	Indep. samples	Station. proc.	Samples:	Time: (s)
static	FER=0.10%	30 000	4	-	120 000	2 400.0
Ib	RBER=0.10%	30 000	10	-	300 000	45.5
II	RBER=2.0%	1 500	10	-	15 000	3.8
TU50	FER=8.0%	375	4	1 300	3 000	60.0
Ib	RBER=0.21%	14 286	10	171 600	171 600	26.0
II	RBER=7.0%	429	10	101 400	101 400	26.0
TU50(SFH)	FER=3.0%	1 000	4	1 300	4 000	80.0
Ib	RBER=0.11%	27 273	10	171 600	272 730	41.3
II	RBER=8.0%	375	10	101 400	101 400	26.0
RA250	FER=3.0%	1 000	4	271	4 000	80.0
Ib	RBER=0.10%	30 000	10	35 750	300 000	45.5
II	RBER=7.0%	429	10	21 125	21 125	5.4
HT100	FER=7.0%	429	4	650	1 716	34.3
Ib	RBER=0.20%	15 000	10	85 800	150 000	22.7
II	RBER=9.0%	333	10	50 700	50 700	13.0
TU3	FER=23%	130	4	21 667	21 667	433.3
Ib	RBER=0.20%	15 000	10	2860 000	2860 000	433.3
II	RBER=3.0%	1 000	10	1690 000	1690 000	433.3
TU3(SFH)	FER=3.0%	1 000	4	21 667	21 667	433.3
Ib	RBER=0.1%	30 000	10	2860 000	2860 000	433.3
II	RBER=8.0%	375	10	1690 000	1690 000	433.3
TU50	FER=9.0%	333	4	1 300	1 332	26.6
Ib	RBER=0.2%	15 000	10	171 600	171 600	26.0
II	RBER=7.0%	429	10	101 400	101 400	26.0
TU50(SFH)	FER=3.0%	1 000	4	1 300	4 000	80.0
Ib	RBER=0.1%	30 000	10	171 600	300 000	45.5
II	RBER=8.0%	375	10	101 400	101 400	26.0
RA250	FER=4.0%	750	4	271	3 000	60.0
Ib	RBER=0.13%	23 077	10	35 750	230 770	35.0
II	RBER=8.0%	375	10	21 125	21 125	5.4
TI5	FER=8.0%	375	4	13 000	13 000	260.0
Ib	RBER=0.21%	14 286	10	1 716 000	1 716 000	260.0
II	RBER=7.0%	429	10	1 014 000	1 014 000	260.0
TI5	FER=9.0%	333	4	13 000	13 000	260.0
Ib	RBER=0.2%	15 000	10	1 716 000	1 716 000	260.0
II	RBER=7.0%	429	10	1 014 000	1 014 000	260.0

GSM 900 TCH/AFS12.2

(FER: 50 events/s, RBER class Ib: 12200 events/s, frame filling = 24/26)

Prop. cond.	Error rate	Stat. sign.	Indep. samples	Station. proc.	Samples:	Time: (s)
Static (Ib)	RBER = 0,001 %	3000000	10	-	30000000	2459
TU50 (no SFH)	FER = 4,9 %	612,2	4	1300	2449	49
Ib	RBER = 1,5 %	2000	10	317200	317200	26
TU50 (ideal SFH)	FER = 2,4 %	1250	4	1300	5000	100
Ib	RBER = 1,5 %	2000	10	317200	317200	26
RA250 (no SFH)	FER = 1,4 %	2142,9	4	270,8	8571,4	171,4
Ib	RBER = 1,2 %	2500	10	66083,3	66083,3	5,4
HT100 (no SFH)	FER = 4,5 %	666,7	4	650	2666,7	53,3
Ib	RBER = 2,1 %	1428,6	10	158600	158600	13
TI5 (no SFH)	FER = 4,9 %	612,2	4	13000	13000	260
Ib	RBER = 1,5 %	2000	10	3172000	3172000	260
TU3 (no SFH)	FER = 22 %	136,4	4	21666,7	21666,7	433,3
Ib	RBER = 0,9 %	3333,3	10	5286666,7	5286666,7	433,3
TU50 (no SFH)	FER = 6 %	500	4	1300	2000	40
Ib	RBER = 1,7 %	1764,7	10	317200	317200	26
TU50 (ideal SFH)	FER = 3,5 %	857,1	4	1300	3428,6	68,6
Ib	RBER = 1,7 %	1764,7	10	317200	317200	26
RA250 (no SFH)	FER = 2,5 %	1200	4	270,8	4800	96
Ib	RBER = 1,5 %	2000	10	66083,3	66083,3	5,4
TI5 (no SFH)	FER = 6 %	500	4	13000	13000	260
Ib	RBER = 1,7 %	1764,7	10	3172000	3172000	260

GSM 900 TCH/AFS10.2

(FER: 50 events/s, RBER class Ib: 10200 events/s, frame filling = 24/26)

Prop. cond.	Error rate	Stat. sign.	Indep. samples	Station. proc.	Samples:	Time: (s)
Static (Ib)	RBER = 0,001 %	3000000	10	-	30000000	2941,2
TU50 (no SFH)	FER = 2,1 %	1428,6	4	1300	5714,3	114,3
Ib	RBER = 0,23 %	13043,5	10	265200	265200	26
TU50 (ideal SFH)	FER = 0,85 %	3529,4	4	1300	14117,6	282,4
Ib	RBER = 0,15 %	20000	10	265200	265200	26
RA250 (no SFH)	FER = 0,45 %	6666,7	4	270,8	26666,7	533,3
Ib	RBER = 0,092 %	32608,7	10	55250	326087	32
HT100 (no SFH)	FER = 1,6 %	1875	4	650	7500	150
Ib	RBER = 0,26 %	11538,5	10	132600	132600	13
TI5 (no SFH)	FER = 2,1 %	1428,6	4	13000	13000	260
Ib	RBER = 0,23 %	13043,5	10	2652000	2652000	260
TU3 (no SFH)	FER = 18 %	166,7	4	21666,7	21666,7	433,3
Ib	RBER = 0,53 %	5660,4	10	4420000	4420000	433,3
TU50 (no SFH)	FER = 2,7 %	1111,1	4	1300	4444,4	88,9
Ib	RBER = 0,3 %	10000	10	265200	265200	26
TU50 (ideal SFH)	FER = 1,4 %	2142,9	4	1300	8571,4	171,4
Ib	RBER = 0,21 %	14285,7	10	265200	265200	26
RA250 (no SFH)	FER = 0,92 %	3260,9	4	270,8	13043,5	260,9
Ib	RBER = 0,16 %	18750	10	55250	187500	18,4
TI5 (no SFH)	FER = 2,7 %	1111,1	4	13000	13000	260
Ib	RBER = 0,3 %	10000	10	2652000	2652000	260

GSM 900 TCH/AFS7.95

(FER: 50 events/s, RBER class Ib: 7950 events/s, frame filling = 24/26)

Prop. cond.	Error rate	Stat. sign.	Indep. samples	Station. proc.	Samples:	Time: (s)
TU50 (no SFH)	FER = 0,36 %	8333,3	4	1300	33333,3	666,7
Ib	RBER = 0,11 %	27272,7	10	206700	272727,3	34,3
TU50 (ideal SFH)	FER = 0,045 %	66666,7	4	1300	266666,7	5333,3
Ib	RBER = 0,032 %	93750	10	206700	937500	117,9
RA250 (no SFH)	FER = 0,024 %	125000	4	270,8	500000	10000
Ib	RBER = 0,02 %	150000	10	43062,5	1500000	188,7
HT100 (no SFH)	FER = 0,096 %	31250	4	650	125000	2500
Ib	RBER = 0,06 %	50000	10	103350	500000	62,9
TI5 (no SFH)	FER = 0,36 %	8333,3	4	13000	33333,3	666,7
Ib	RBER = 0,11 %	27272,7	10	2067000	2067000	260
TU3 (no SFH)	FER = 13 %	230,8	4	21666,7	21666,7	433,3
Ib	RBER = 0,66 %	4545,5	10	3445000	3445000	433,3
TU50 (no SFH)	FER = 0,51 %	5882,4	4	1300	23529,4	470,6
Ib	RBER = 0,15 %	20000	10	206700	206700	26
TU50 (ideal SFH)	FER = 0,12 %	25000	4	1300	100000	2000
Ib	RBER = 0,065 %	46153,8	10	206700	461538,5	58,1
RA250 (no SFH)	FER = 0,073 %	41095,9	4	270,8	164383,6	3287,7
Ib	RBER = 0,044 %	68181,8	10	43062,5	681818,2	85,8
TI5 (no SFH)	FER = 0,51 %	5882,4	4	13000	23529,4	470,6
Ib	RBER = 0,15 %	20000	10	2067000	2067000	260
TU3 (no SFH)	FER = 26 %	115,4	4	21666,7	21666,7	433,3
Ib	RBER = 1,2 %	2500	10	3445000	3445000	433,3
TU50 (no SFH)	FER = 5,3 %	566	4	1300	2264,2	45,3
Ib	RBER = 1 %	3000	10	206700	206700	26
TU50 (ideal SFH)	FER = 2,7 %	1111,1	4	1300	4444,4	88,9
Ib	RBER = 0,78 %	3846,2	10	206700	206700	26
RA250 (no SFH)	FER = 1,8 %	1666,7	4	270,8	6666,7	133,3
Ib	RBER = 0,6 %	5000	10	43062,5	50000	6,3
TI5 (no SFH)	FER = 5,3 %	566	4	13000	13000	260
Ib	RBER = 1 %	3000	10	2067000	2067000	260

GSM 900 TCH/AFS7.4

(FER: 50 events/s, RBER class Ib: 7400 events/s, frame filling = 24/26)

Prop. cond.	Error rate	Stat. sign.	Indep. samples	Station. proc.	Samples:	Time: (s)
TU50 (no SFH)	FER = 0,41 %	7317,1	4	1300	29268,3	585,4
lb	RBER = 0,054 %	55555,6	10	192400	555555,6	75,1
TU50 (ideal SFH)	FER = 0,069 %	43478,3	4	1300	173913	3478,3
lb	RBER = 0,016 %	187500	10	192400	1875000	253,4
RA250 (no SFH)	FER = 0,028 %	107142,9	4	270,8	428571,4	8571,4
lb	RBER = 0,009 %	333333,3	10	40083,3	3333333,3	450,5
HT100 (no SFH)	FER = 0,13 %	23076,9	4	650	92307,7	1846,2
lb	RBER = 0,033 %	90909,1	10	96200	909090,9	122,9
TI5 (no SFH)	FER = 0,41 %	7317,1	4	13000	29268,3	585,4
lb	RBER = 0,054 %	55555,6	10	1924000	1924000	260
TU3 (no SFH)	FER = 14 %	214,3	4	21666,7	21666,7	433,3
lb	RBER = 0,43 %	6976,7	10	3206666,7	3206666,7	433,3
TU50 (no SFH)	FER = 0,56 %	5357,1	4	1300	21428,6	428,6
lb	RBER = 0,072 %	41666,7	10	192400	416666,7	56,3
TU50 (ideal SFH)	FER = 0,16 %	18750	4	1300	75000	1500
lb	RBER = 0,032 %	93750	10	192400	937500	126,7
RA250 (no SFH)	FER = 0,09 %	33333,3	4	270,8	133333,3	2666,7
lb	RBER = 0,018 %	166666,7	10	40083,3	1666666,7	225,2
TI5 (no SFH)	FER = 0,56 %	5357,1	4	13000	21428,6	428,6
lb	RBER = 0,072 %	41666,7	10	1924000	1924000	260
TU3 (no SFH)	FER = 26 %	115,4	4	21666,7	21666,7	433,3
lb	RBER = 0,79 %	3797,5	10	3206666,7	3206666,7	433,3
TU50 (no SFH)	FER = 5,4 %	555,6	4	1300	2222,2	44,4
lb	RBER = 0,52 %	5769,2	10	192400	192400	26
TU50 (ideal SFH)	FER = 3,1 %	967,7	4	1300	3871	77,4
lb	RBER = 0,38 %	7894,7	10	192400	192400	26
RA250 (no SFH)	FER = 2 %	1500	4	270,8	6000	120
lb	RBER = 0,28 %	10714,3	10	40083,3	107142,9	14,5
TI5 (no SFH)	FER = 5,4 %	555,6	4	13000	13000	260
lb	RBER = 0,52 %	5769,2	10	1924000	1924000	260

GSM 900 TCH/AFS6.7

(FER: 50 events/s, RBER class Ib: 6700 events/s, frame filling = 24/26)

Prop. cond.	Error rate	Stat. sign.	Indep. samples	Station. proc.	Samples:	Time: (s)
TU50 (no SFH)	FER = 0,16 %	18750	4	1300	75000	1500
Ib	RBER = 0,082 %	36585,4	10	174200	365853,7	54,6
TU50 (ideal SFH)	FER = 0,017 %	176470,6	4	1300	705882,4	14117,6
Ib	RBER = 0,022 %	136363,6	10	174200	1363636,4	203,5
RA250 (no SFH)	FER = 0,01 %	300000	4	270,8	1200000	24000
Ib	RBER = 0,013 %	230769,2	10	36291,7	2307692,3	344,4
HT100 (no SFH)	FER = 0,026 %	115384,6	4	650	461538,5	9230,8
Ib	RBER = 0,044 %	68181,8	10	87100	681818,2	101,8
TI5 (no SFH)	FER = 0,16 %	18750	4	13000	75000	1500
Ib	RBER = 0,082 %	36585,4	10	1742000	1742000	260
TU3 (no SFH)	FER = 11 %	272,7	4	21666,7	21666,7	433,3
Ib	RBER = 0,75 %	4000	10	2903333,3	2903333,3	433,3
TU50 (no SFH)	FER = 0,21 %	14285,7	4	1300	57142,9	1142,9
Ib	RBER = 0,11 %	27272,7	10	174200	272727,3	40,7
TU50 (ideal SFH)	FER = 0,041 %	73170,7	4	1300	292682,9	5853,7
Ib	RBER = 0,042 %	71428,6	10	174200	714285,7	106,6
RA250 (no SFH)	FER = 0,021 %	142857,1	4	270,8	571428,6	11428,6
Ib	RBER = 0,028 %	107142,9	10	36291,7	1071428,6	159,9
TI5 (no SFH)	FER = 0,21 %	14285,7	4	13000	57142,9	1142,9
Ib	RBER = 0,11 %	27272,7	10	1742000	1742000	260
TU3 (no SFH)	FER = 23 %	130,4	4	21666,7	21666,7	433,3
Ib	RBER = 1,4 %	2142,9	10	2903333,3	2903333,3	433,3
TU50 (no SFH)	FER = 2,9 %	1034,5	4	1300	4137,9	82,8
Ib	RBER = 0,86 %	3488,4	10	174200	174200	26
TU50 (ideal SFH)	FER = 1,2 %	2500	4	1300	10000	200
Ib	RBER = 0,6 %	5000	10	174200	174200	26
RA250 (no SFH)	FER = 0,75 %	4000	4	270,8	16000	320
Ib	RBER = 0,44 %	6818,2	10	36291,7	68181,8	10,2
TI5 (no SFH)	FER = 2,9 %	1034,5	4	13000	13000	260
Ib	RBER = 0,86 %	3488,4	10	1742000	1742000	260

GSM 900 TCH/AFS.9

(FER: 50 events/s, RBER class Ib: 5900 events/s, frame filling = 24/26)

Prop. cond.	Error rate	Stat. sign.	Indep. samples	Station. proc.	Samples:	Time: (s)
TU50 (no SFH)	FER = 0,094 %	31914,9	4	1300	127659,6	2553,2
Ib	RBER = 0,014 %	214285,7	10	153400	2142857,1	363,2
TU50 (ideal SFH)	FER = 0,01 %	300000	4	1300	1200000	24000
Ib	RBER = 0,001 %	3000000	10	153400	30000000	5084,7
RA250 (no SFH)	FER = 0,01 %	300000	4	270,8	1200000	24000
Ib	RBER = 0,001 %	3000000	10	31958,3	30000000	5084,7
HT100 (no SFH)	FER = 0,011 %	272727,3	4	650	1090909,1	21818,2
Ib	RBER = 0,003 %	1000000	10	76700	10000000	1694,9
TI5 (no SFH)	FER = 0,094 %	31914,9	4	13000	127659,6	2553,2
Ib	RBER = 0,014 %	214285,7	10	1534000	2142857,1	363,2
TU3 (no SFH)	FER = 10 %	300	4	21666,7	21666,7	433,3
Ib	RBER = 0,38 %	7894,7	10	2556666,7	2556666,7	433,3
TU50 (no SFH)	FER = 0,12 %	25000	4	1300	100000	2000
Ib	RBER = 0,022 %	136363,6	10	153400	1363636,4	231,1
TU50 (ideal SFH)	FER = 0,018 %	166666,7	4	1300	666666,7	13333,3
Ib	RBER = 0,005 %	600000	10	153400	6000000	1016,9
RA250 (no SFH)	FER = 0,01 %	300000	4	270,8	1200000	24000
Ib	RBER = 0,003 %	1000000	10	31958,3	10000000	1694,9
TI5 (no SFH)	FER = 0,12 %	25000	4	13000	100000	2000
Ib	RBER = 0,022 %	136363,6	10	1534000	1534000	260
TU3 (no SFH)	FER = 21 %	142,9	4	21666,7	21666,7	433,3
Ib	RBER = 0,74 %	4054,1	10	2556666,7	2556666,7	433,3
TU50 (no SFH)	FER = 2 %	1500	4	1300	6000	120
Ib	RBER = 0,23 %	13043,5	10	153400	153400	26
TU50 (ideal SFH)	FER = 0,7 %	4285,7	4	1300	17142,9	342,9
Ib	RBER = 0,12 %	25000	10	153400	250000	42,4
RA250 (no SFH)	FER = 0,4 %	7500	4	270,8	30000	600
Ib	RBER = 0,079 %	37974,7	10	31958,3	379746,8	64,4
TI5 (no SFH)	FER = 2 %	1500	4	13000	13000	260
Ib	RBER = 0,23 %	13043,5	10	1534000	1534000	260

GSM 900 TCH/AFS.15

(FER: 50 events/s, RBER class Ib: 5150 events/s, frame filling = 24/26)

Prop. cond.	Error rate	Stat. sign.	Indep. samples	Station. proc.	Samples:	Time: (s)
TU50 (no SFH)	FER = 0,07 %	42857,1	4	1300	171428,6	3428,6
Ib	RBER = 0,014 %	214285,7	10	133900	2142857,1	416,1
TU50 (ideal SFH)	FER = 0,01 %	300000	4	1300	1200000	24000
Ib	RBER = 0,001 %	3000000	10	133900	30000000	5825,2
RA250 (no SFH)	FER = 0,01 %	300000	4	270,8	1200000	24000
Ib	RBER = 0,001 %	3000000	10	27895,8	30000000	5825,2
HT100 (no SFH)	FER = 0,01 %	300000	4	650	1200000	24000
Ib	RBER = 0,002 %	1500000	10	66950	15000000	2912,6
TI5 (no SFH)	FER = 0,07 %	42857,1	4	13000	171428,6	3428,6
Ib	RBER = 0,014 %	214285,7	10	1339000	2142857,1	416,1
TU3 (no SFH)	FER = 9,2 %	326,1	4	21666,7	21666,7	433,3
Ib	RBER = 0,44 %	6818,2	10	2231666,7	2231666,7	433,3
TU50 (no SFH)	FER = 0,081 %	37037	4	1300	148148,1	2963
Ib	RBER = 0,019 %	157894,7	10	133900	1578947,4	306,6
TU50 (ideal SFH)	FER = 0,011 %	272727,3	4	1300	1090909,1	21818,2
Ib	RBER = 0,003 %	1000000	10	133900	10000000	1941,7
RA250 (no SFH)	FER = 0,01 %	300000	4	270,8	1200000	24000
Ib	RBER = 0,002 %	1500000	10	27895,8	15000000	2912,6
TI5 (no SFH)	FER = 0,081 %	37037	4	13000	148148,1	2963
Ib	RBER = 0,019 %	157894,7	10	1339000	1578947,4	306,6
TU3 (no SFH)	FER = 19 %	157,9	4	21666,7	21666,7	433,3
Ib	RBER = 0,85 %	3529,4	10	2231666,7	2231666,7	433,3
TU50 (no SFH)	FER = 1,4 %	2142,9	4	1300	8571,4	171,4
Ib	RBER = 0,22 %	13636,4	10	133900	136363,6	26,5
TU50 (ideal SFH)	FER = 0,47 %	6383	4	1300	25531,9	510,6
Ib	RBER = 0,11 %	27272,7	10	133900	272727,3	53
RA250 (no SFH)	FER = 0,25 %	12000	4	270,8	48000	960
Ib	RBER = 0,069 %	43478,3	10	27895,8	434782,6	84,4
TI5 (no SFH)	FER = 1,4 %	2142,9	4	13000	13000	260
Ib	RBER = 0,22 %	13636,4	10	1339000	1339000	260

GSM 900 TCH/AFS4.75

(FER: 50 events/s, RBER class Ib: 4750 events/s, frame filling = 24/26)

Prop. cond.	Error rate	Stat. sign.	Indep. samples	Station. proc.	Samples:	Time: (s)
TU50 (no SFH)	FER = 0,029 %	103448,3	4	1300	413793,1	8275,9
Ib	RBER = 0,005 %	600000	10	123500	6000000	1263,2
TU50 (ideal SFH)	FER = 0,01 %	300000	4	1300	1200000	24000
Ib	RBER = 0,001 %	3000000	10	123500	30000000	6315,8
RA250 (no SFH)	-	-	4	270,8	-	-
Ib	RBER = 0,001 %	3000000	10	25729,2	30000000	6315,8
HT100 (no SFH)	FER = 0,01 %	300000	4	650	1200000	24000
Ib	RBER = 0,001 %	3000000	10	61750	30000000	6315,8
TI5 (no SFH)	FER = 0,029 %	103448,3	4	13000	413793,1	8275,9
Ib	RBER = 0,005 %	600000	10	1235000	6000000	1263,2
TU3 (no SFH)	FER = 7,9 %	379,7	4	21666,7	21666,7	433,3
Ib	RBER = 0,32 %	9375	10	2058333,3	2058333,3	433,3
TU50 (no SFH)	FER = 0,036 %	83333,3	4	1300	333333,3	6666,7
Ib	RBER = 0,006 %	500000	10	123500	5000000	1052,6
TU50 (ideal SFH)	FER = 0,01 %	300000	4	1300	1200000	24000
Ib	RBER = 0,001 %	3000000	10	123500	30000000	6315,8
RA250 (no SFH)	FER = 0,01 %	300000	4	270,8	1200000	24000
Ib	RBER = 0,001 %	3000000	10	25729,2	30000000	6315,8
TI5 (no SFH)	FER = 0,036 %	83333,3	4	13000	333333,3	6666,7
Ib	RBER = 0,006 %	500000	10	1235000	5000000	1052,6
TU3 (no SFH)	FER = 17 %	176,5	4	21666,7	21666,7	433,3
Ib	RBER = 0,62 %	4838,7	10	2058333,3	2058333,3	433,3
TU50 (no SFH)	FER = 0,82 %	3658,5	4	1300	14634,1	292,7
Ib	RBER = 0,11 %	27272,7	10	123500	272727,3	57,4
TU50 (ideal SFH)	FER = 0,23 %	13043,5	4	1300	52173,9	1043,5
Ib	RBER = 0,033 %	90909,1	10	123500	909090,9	191,4
RA250 (no SFH)	FER = 0,11 %	27272,7	4	270,8	109090,9	2181,8
Ib	RBER = 0,019 %	157894,7	10	25729,2	1578947,4	332,4
TI5 (no SFH)	FER = 0,82 %	3658,5	4	13000	14634,1	292,7
Ib	RBER = 0,11 %	27272,7	10	1235000	1235000	260

GSM 900 TCH/AHS7.95

(FER: 50 events/s, RBER class Ib: 2800 events/s, RBER class II : 1800 events/s, frame filling = 12/26)

Prop. cond.	Error rate	Stat. sign.	Indep. samples	Station. proc.	Samples:	Time: (s)
Static	FER = 0,01 %	300000	4	-	1200000	24000
Ib	RBER = 0,004 %	750000	10	-	7500000	2678,6
II	RBER = 0,66 %	4545,5	10	-	45454,5	25,3
TU50 (no SFH)	FER = 20 %	150	4	2600	2600	52
Ib	RBER = 2,3 %	1304,3	10	145600	145600	52
II	RBER = 5 %	600	10	93600	93600	52
TU50 (ideal SFH)	FER = 20 %	150	4	2600	2600	52
Ib	RBER = 2,3 %	1304,3	10	145600	145600	52
II	RBER = 5 %	600	10	93600	93600	52
RA250 (no SFH)	FER = 17 %	176,5	4	541,7	705,9	14,1
Ib	RBER = 2 %	1500	10	30333,3	30333,3	10,8
II	RBER = 4,7 %	638,3	10	19500	19500	10,8
HT100 (no SFH)	FER = 28 %	107,1	4	1300	1300	26
Ib	RBER = 2,9 %	1034,5	10	72800	72800	26
II	RBER = 5,7 %	526,3	10	46800	46800	26
TI5 (no SFH)	FER = 20 %	150	4	26000	26000	520
Ib	RBER = 2,3 %	1304,3	10	1456000	1456000	520
II	RBER = 5 %	600	10	936000	936000	520
TU3 (no SFH)	FER = 27 %	111,1	4	43333,3	43333,3	866,7
Ib	RBER = 0,84 %	3571,4	10	2426666,7	2426666,7	866,7
II	RBER = 1,7 %	1764,7	10	1560000	1560000	866,7
TU50 (no SFH)	FER = 22 %	136,4	4	2600	2600	52
Ib	RBER = 2,3 %	1304,3	10	145600	145600	52
II	RBER = 5,3 %	566	10	93600	93600	52
TU50 (ideal SFH)	FER = 22 %	136,4	4	2600	2600	52
Ib	RBER = 2,3 %	1304,3	10	145600	145600	52
II	RBER = 5,3 %	566	10	93600	93600	52
RA250 (no SFH)	FER = 21 %	142,9	4	541,7	571,4	11,4
Ib	RBER = 2,1 %	1428,6	10	30333,3	30333,3	10,8
II	RBER = 5 %	600	10	19500	19500	10,8
TI5 (no SFH)	FER = 22 %	136,4	4	26000	26000	520
Ib	RBER = 2,3 %	1304,3	10	1456000	1456000	520
II	RBER = 5,3 %	566	10	936000	936000	520
TU3 (no SFH)	FER = 14 %	214,3	4	43333,3	43333,3	866,7
Ib	RBER = 0,48 %	6250	10	2426666,7	2426666,7	866,7
II	RBER = 1 %	3000	10	1560000	1560000	866,7
TU50 (no SFH)	FER = 6,7 %	447,8	4	2600	2600	52
Ib	RBER = 1 %	3000	10	145600	145600	52
II	RBER = 3,2 %	937,5	10	93600	93600	52
TU50 (ideal SFH)	FER = 6,7 %	447,8	4	2600	2600	52
Ib	RBER = 1 %	3000	10	145600	145600	52
II	RBER = 3,2 %	937,5	10	93600	93600	52
RA250 (no SFH)	FER = 7 %	428,6	4	541,7	1714,3	34,3
Ib	RBER = 1 %	3000	10	30333,3	30333,3	10,8
II	RBER = 3,2 %	937,5	10	19500	19500	10,8
TI5 (no SFH)	FER = 6,7 %	447,8	4	26000	26000	520
Ib	RBER = 1 %	3000	10	1456000	1456000	520
II	RBER = 3,2 %	937,5	10	936000	936000	520

GSM 900 TCH/AHS7.4

(FER: 50 events/s, RBER class Ib: 2950 events/s, RBER class II : 1400 events/s, frame filling = 12/26)

Prop. cond.	Error rate	Stat. sign.	Indep. samples	Station. proc.	Samples:	Time: (s)
Static	FER = 0,01 %	300000	4	-	1200000	24000
Ib	RBER = 0,001 %	3000000	10	-	30000000	10169,5
II	RBER = 0,66 %	4545,5	10	-	45454,5	32,5
TU50 (no SFH)	FER = 16 %	187,5	4	2600	2600	52
Ib	RBER = 1,4 %	2142,9	10	153400	153400	52
II	RBER = 5,3 %	566	10	72800	72800	52
TU50 (ideal SFH)	FER = 16 %	187,5	4	2600	2600	52
Ib	RBER = 1,4 %	2142,9	10	153400	153400	52
II	RBER = 5,3 %	566	10	72800	72800	52
RA250 (no SFH)	FER = 14 %	214,3	4	541,7	857,1	17,1
Ib	RBER = 1,1 %	2727,3	10	31958,3	31958,3	10,8
II	RBER = 5 %	600	10	15166,7	15166,7	10,8
HT100 (no SFH)	FER = 22 %	136,4	4	1300	1300	26
Ib	RBER = 1,8 %	1666,7	10	76700	76700	26
II	RBER = 6,1 %	491,8	10	36400	36400	26
TI5 (no SFH)	FER = 16 %	187,5	4	26000	26000	520
Ib	RBER = 1,4 %	2142,9	10	1534000	1534000	520
II	RBER = 5,3 %	566	10	728000	728000	520
TU3 (no SFH)	FER = 25 %	120	4	43333,3	43333,3	866,7
Ib	RBER = 0,68 %	4411,8	10	2556666,7	2556666,7	866,7
II	RBER = 1,9 %	1578,9	10	1213333,3	1213333,3	866,7
TU50 (no SFH)	FER = 18 %	166,7	4	2600	2600	52
Ib	RBER = 1,4 %	2142,9	10	153400	153400	52
II	RBER = 5,6 %	535,7	10	72800	72800	52
TU50 (ideal SFH)	FER = 18 %	166,7	4	2600	2600	52
Ib	RBER = 1,4 %	2142,9	10	153400	153400	52
II	RBER = 5,6 %	535,7	10	72800	72800	52
RA250 (no SFH)	FER = 17 %	176,5	4	541,7	705,9	14,1
Ib	RBER = 1,3 %	2142,9	10	31958,3	31958,3	10,8
II	RBER = 5,4 %	555,6	10	15166,7	15166,7	10,8
TI5 (no SFH)	FER = 18 %	166,7	4	26000	26000	520
Ib	RBER = 1,4 %	2142,9	10	1534000	1534000	520
II	RBER = 5,6 %	535,7	10	728000	728000	520
TU3 (no SFH)	FER = 13 %	230,8	4	43333,3	43333,3	866,7
Ib	RBER = 0,38 %	7894,7	10,0	2556666,7	2556666,7	866,7
II	RBER = 1,2 %	2500	10	1213333,3	1213333,3	866,7
TU50 (no SFH)	FER = 4,8 %	625	4	2600	2600	52
Ib	RBER = 0,51 %	5882,4	10	153400	153400	52
II	RBER = 3,3 %	909,1	10	72800	72800	52
TU50 (ideal SFH)	FER = 4,8 %	625	4	2600	2600	52
Ib	RBER = 0,51 %	5882,4	10	153400	153400	52
II	RBER = 3,3 %	909,1	10	72800	72800	52
RA250 (no SFH)	FER = 5,3 %	566	4	541,7	2264,2	45,3
Ib	RBER = 0,5 %	6000	10	31958,3	60000	20,3
II	RBER = 3,4 %	882,4	10	15166,7	15166,7	10,8
TI5 (no SFH)	FER = 4,8 %	625	4	26000	26000	520
Ib	RBER = 0,51 %	5882,4	10	1534000	1534000	520
II	RBER = 3,3 %	909,1	10	728000	728000	520

GSM 900 TCH/AHS6.7

(FER: 50 events/s, RBER class Ib: 2750 events/s, RBER class II : 1200 events/s, frame filling = 12/26)

Prop. cond.	Error rate	Stat. sign.	Indep. samples	Station. proc.	Samples:	Time: (s)
Static	FER = 0,01 %	300000	4	-	1200000	24000
Ib	RBER = 0,001 %	3000000	10	-	30000000	10909,1
II	RBER = 0,66 %	4545,5	10	-	45454,5	37,9
TU50 (no SFH)	FER = 9,2 %	326,1	4	2600	2600	52
Ib	RBER = 1,1 %	2727,3	10	143000	143000	52
II	RBER = 5,8 %	517,2	10	62400	62400	52
TU50 (ideal SFH)	FER = 9,2 %	326,1	4	2600	2600	52
Ib	RBER = 1,1 %	2727,3	10	143000	143000	52
II	RBER = 5,8 %	517,2	10	62400	62400	52
RA250 (no SFH)	FER = 8 %	375	4	541,7	1500	30
Ib	RBER = 0,93 %	3225,8	10	29791,7	32258,1	11,7
II	RBER = 5,5 %	545,5	10	13000	13000	10,8
HT100 (no SFH)	FER = 13 %	230,8	4	1300	1300	26
Ib	RBER = 1,5 %	2000	10	71500	71500	26
II	RBER = 6,6 %	454,5	10	31200	31200	26
TI5 (no SFH)	FER = 9,2 %	326,1	4	26000	26000	520
Ib	RBER = 1,1 %	2727,3	10	1430000	1430000	520
II	RBER = 5,8 %	517,2	10	624000	624000	520
TU3 (no SFH)	FER = 23 %	130,4	4	43333,3	43333,3	866,7
Ib	RBER = 0,71 %	4225,4	10	2383333,3	2383333,3	866,7
II	RBER = 2,3 %	1304,3	10	1040000	1040000	866,7
TU50 (no SFH)	FER = 11 %	272,7	4	2600	2600	52
Ib	RBER = 1,2 %	2500	10	143000	143000	52
II	RBER = 6,2 %	483,9	10	62400	62400	52
TU50 (ideal SFH)	FER = 11 %	272,7	4	2600	2600	52
Ib	RBER = 1,2 %	2500	10	143000	143000	52
II	RBER = 6,2 %	483,9	10	62400	62400	52
RA250 (no SFH)	FER = 11 %	272,7	4	541,7	1090,9	21,8
Ib	RBER = 1,1 %	2727,3	10	29791,7	29791,7	10,8
II	RBER = 6 %	500	10	13000	13000	10,8
TI5 (no SFH)	FER = 11 %	272,7	4	26000	26000	520
Ib	RBER = 1,2 %	2500	10	1430000	1430000	520
II	RBER = 6,2 %	483,9	10	624000	624000	520
TU3 (no SFH)	FER = 11 %	272,7	4	43333,3	43333,3	866,7
Ib	RBER = 0,39 %	7692,3	10	2383333,3	2383333,3	866,7
II	RBER = 1,4 %	2142,9	10	1040000	1040000	866,7
TU50 (no SFH)	FER = 2,3 %	1304,3	4	2600	5217,4	104,3
Ib	RBER = 0,39 %	7692,3	10	143000	143000	52
II	RBER = 3,6 %	833,3	10	62400	62400	52
TU50 (ideal SFH)	FER = 2,3 %	1304,3	4	2600	5217,4	104,3
Ib	RBER = 0,39 %	7692,3	10	143000	143000	52
II	RBER = 3,6 %	833,3	10	62400	62400	52
RA250 (no SFH)	FER = 2,9 %	1034,5	4	541,7	4137,9	82,8
Ib	RBER = 0,4 %	7500	10	29791,7	75000	27,3
II	RBER = 3,6 %	833,3	10	13000	13000	10,8
TI5 (no SFH)	FER = 2,3 %	1304,3	4	26000	26000	520
Ib	RBER = 0,39 %	7692,3	10	1430000	1430000	520
II	RBER = 3,6 %	833,3	10	624000	624000	520

GSM 900 TCH/AHS5.9

(FER: 50 events/s, RBER class Ib: 2350 events/s, RBER class II : 800 events/s, frame filling = 12/26)

Prop. cond.	Error rate	Stat. sign.	Indep. samples	Station. proc.	Samples:	Time: (s)
Static (II)	RBER = 0,66 %	4545,5	10	-	45454,5	56,8
TU50 (no SFH)	FER = 5,7 %	526,3	4	2600	2600	52
Ib	RBER = 0,51 %	5882,4	10	122200	122200	52
II	RBER = 6 %	500	10	41600	41600	52
TU50 (ideal SFH)	FER = 5,7 %	526,3	4	2600	2600	52
Ib	RBER = 0,51 %	5882,4	10	122200	122200	52
II	RBER = 6 %	500	10	41600	41600	52
RA250 (no SFH)	FER = 4,9 %	612,2	4	541,7	2449	49
Ib	RBER = 0,42 %	7142,9	10	25458,3	71428,6	30,4
II	RBER = 5,7 %	526,3	10	8666,7	8666,7	10,8
HT100 (no SFH)	FER = 8,6 %	348,8	4	1300	1395,3	27,9
Ib	RBER = 0,73 %	4109,6	10	61100	61100	26
II	RBER = 6,8 %	441,2	10	20800	20800	26
TI5 (no SFH)	FER = 5,7 %	526,3	4	26000	26000	520
Ib	RBER = 0,51 %	5882,4	10	1222000	1222000	520
II	RBER = 6 %	500	10	416000	416000	520
TU3 (no SFH)	FER = 21 %	142,9	4	43333,3	43333,3	866,7
Ib	RBER = 0,55 %	5454,5	10	2036666,7	2036666,7	866,7
II	RBER = 2,6 %	1153,8	10	693333,3	693333,3	866,7
TU50 (no SFH)	FER = 7,1 %	422,5	4	2600	2600	52
Ib	RBER = 0,57 %	5263,2	10	122200	122200	52
II	RBER = 6,5 %	461,5	10	41600	41600	52
TU50 (ideal SFH)	FER = 7,1 %	422,5	4	2600	2600	52
Ib	RBER = 0,57 %	5263,2	10	122200	122200	52
II	RBER = 6,5 %	461,5	10	41600	41600	52
RA250 (no SFH)	FER = 7 %	428,6	4	541,7	1714,3	34,3
Ib	RBER = 0,51 %	5882,4	10	25458,3	58823,5	25
II	RBER = 6,3 %	476,2	10	8666,7	8666,7	10,8
TI5 (no SFH)	FER = 7,1 %	422,5	4	26000	26000	520
Ib	RBER = 0,57 %	5263,2	10	1222000	1222000	520
II	RBER = 6,5 %	461,5	10	416000	416000	520

GSM 900 TCH/AHS5.15

(FER: 50 events/s, RBER class Ib: 2100 events/s, RBER class II : 600 events/s, frame filling = 12/26)

Prop. cond.	Error rate	Stat. sign.	Indep. samples	Station. proc.	Samples:	Time: (s)
Static (II)	RBER = 0,66 %	4545,5	10	-	45454,5	75,8
TU50 (no SFH)	FER = 2,5 %	1200	4	2600	4800	96
Ib	RBER = 0,51 %	5882,4	10	109200	109200	52
II	RBER = 6,3 %	476,2	10	31200	31200	52
TU50 (ideal SFH)	FER = 2,5 %	1200	4	2600	4800	96
Ib	RBER = 0,51 %	5882,4	10	109200	109200	52
II	RBER = 6,3 %	476,2	10	31200	31200	52
RA250 (no SFH)	FER = 2,2 %	1363,6	4	541,7	5454,5	109,1
Ib	RBER = 0,43 %	6976,7	10	22750	69767,4	33,2
II	RBER = 6 %	500	10	6500	6500	10,8
HT100 (no SFH)	FER = 4 %	750	4	1300	3000	60
Ib	RBER = 0,78 %	3846,2	10	54600	54600	26
II	RBER = 7,2 %	416,7	10	15600	15600	26
TI5 (no SFH)	FER = 2,5 %	1200	4	26000	26000	520
Ib	RBER = 0,51 %	5882,4	10	1092000	1092000	520
II	RBER = 6,3 %	476,2	10	312000	312000	520
TU3 (no SFH)	FER = 17 %	176,5	4	43333,3	43333,3	866,7
Ib	RBER = 0,8 %	3750	10	1820000	1820000	866,7
II	RBER = 3,1 %	967,7	10	520000	520000	866,7
TU50 (no SFH)	FER = 3,3 %	909,1	4	2600	3636,4	72,7
Ib	RBER = 0,6 %	5000	10	109200	109200	52
II	RBER = 6,9 %	434,8	10	31200	31200	52
TU50 (ideal SFH)	FER = 3,3 %	909,1	4	2600	3636,4	72,7
Ib	RBER = 0,6 %	5000	10	109200	109200	52
II	RBER = 6,9 %	434,8	10	31200	31200	52
RA250 (no SFH)	FER = 3,5 %	857,1	4	541,7	3428,6	68,6
Ib	RBER = 0,57 %	5263,2	10	22750	52631,6	25,1
II	RBER = 6,7 %	447,8	10	6500	6500	10,8
TI5 (no SFH)	FER = 3,3 %	909,1	4	26000	26000	520
Ib	RBER = 0,6 %	5000	10	1092000	1092000	520
II	RBER = 6,9 %	434,8	10	312000	312000	520

GSM 900 TCH/AHS4.75

(FER: 50 events/s, RBER class Ib: 2200 events/s, RBER class II : 600 events/s, frame filling = 12/26)

Prop. cond.	Error rate	Stat. sign.	Indep. samples	Station. proc.	Samples:	Time: (s)
Static (II)	RBER = 0,66 %	4545,5	10	-	45454,5	75,8
TU50 (no SFH)	FER = 1,2 %	2500	4	2600	10000	200
Ib	RBER = 0,17 %	17647,1	10	114400	176470,6	80,2
II	RBER = 6,4 %	468,8	10	31200	31200	52
TU50 (ideal SFH)	FER = 1,2 %	2500	4	2600	10000	200
Ib	RBER = 0,17 %	17647,1	10	114400	176470,6	80,2
II	RBER = 6,4 %	468,8	10	31200	31200	52
RA250 (no SFH)	FER = 1,2 %	2500	4	541,7	10000	200
Ib	RBER = 0,14 %	21428,6	10	23833,3	214285,7	97,4
II	RBER = 6,2 %	483,9	10	6500	6500	10,8
HT100 (no SFH)	FER = 1,8 %	1666,7	4	1300	6666,7	133,3
Ib	RBER = 0,26 %	11538,5	10	57200	115384,6	52,4
II	RBER = 7,4 %	405,4	10	15600	15600	26
TI5 (no SFH)	FER = 1,2 %	2500	4	26000	26000	520
Ib	RBER = 0,17 %	17647,1	10	1144000	1144000	520
II	RBER = 6,4 %	468,8	10	312000	312000	520
TU3 (no SFH)	FER = 15 %	200	4	43333,3	43333,3	866,7
Ib	RBER = 0,6 %	5000	10	190666,7	190666,7	866,7
II	RBER = 3,6 %	833,3	10	520000	520000	866,7
TU50 (no SFH)	FER = 1,8 %	1666,7	4	2600	6666,7	133,3
Ib	RBER = 0,22 %	13636,4	10	114400	136363,6	62
II	RBER = 7 %	428,6	10	31200	31200	52
TU50 (ideal SFH)	FER = 1,8 %	1666,7	4	2600	6666,7	133,3
Ib	RBER = 0,22 %	13636,4	10	114400	136363,6	62
II	RBER = 7 %	428,6	10	31200	31200	52
RA250 (no SFH)	FER = 2,1 %	1428,6	4	541,7	5714,3	114,3
Ib	RBER = 0,22 %	13636,4	10	23833,3	136363,6	62
II	RBER = 6,9 %	434,8	10	6500	6500	10,8
TI5 (no SFH)	FER = 1,8 %	1666,7	4	26000	26000	520
Ib	RBER = 0,22 %	13636,4	10	1144000	1144000	520
II	RBER = 7 %	428,6	10	312000	312000	520

GSM 900 PDTCH/CS-1 to CS-4

(BLER: 50 events/s, frame filling = 12/52)

Prop. cond.	Error rate	Stat. sign.	Indep. samples	Station. proc.	Samples:	Time: (s)
static	BLER=10%	300	2	-	600	12.0
TU50	BLER=10%	300	2	5 200	5 200	104.0
TU50 (SFH)	BLER=10%	300	2	5 200	5 200	104.0
RA250	BLER=10%	300	2	1 083	1 083	21.7
HT100	BLER=10%	300	2	2 600	2 600	52.0
TI5	BLER=10%	300	2	52 008	52 008	1 040
TU3	BLER=10%	300	2	86 680	86 680	1 733.6
TU3 (SFH)	BLER=10%	300	2	86 680	86 680	1 733.6

GSM 900 PRACH (11 bits), PRACH (8 bits)

(BLER: 217 events/s, frame filling = 1)

Prop. cond.	Error rate	Stat. sign.	Indep. samples	Station. proc.	Samples:	Time: (s)
static	BLER=15%	200	2	-	400	8.0
TU50	BLER=15%	200	2	5 208	5 208	104.1
TU50 (SFH)	BLER=15%	200	2	5 208	5 208	104.1
RA250	BLER=15%	200	2	1 085	1 085	21.7
HT100	BLER=15%	200	2	2 604	2 604	52.1
TI5	BLER=15%	200	2	52 080	52 080	1 041.6
TU3	BLER=15%	200	2	86 800	86 800	1 736
TU3 (SFH)	BLER=15%	200	2	86 800	86 800	1 736

GSM 900 PACCH

(BLER: 50 events/s, frame filling = 12/52)

Prop. Cond.	Error rate	Stat. sign.	Indep. samples	Station. proc.	Samples:	Time: (s)
Static	BLER=10%	300	2	-	3 000	60.0
TU50	BLER=10%	300	2	5 200	5 200	104.0
TU50 (SFH)	BLER=10%	300	2	5 200	5 200	104.0
RA250	BLER=10%	300	2	1 083	1 083	21.7
HT100	BLER=10%	300	2	2 600	2 600	52.0
TI5	BLER=10%	300	2	52 008	52 008	1 040
TU3	BLER=10%	300	2	86 680	86 680	1 733.6
TU3 (SFH)	BLER=10%	300	2	86 680	86 680	1 733.6

C.2 DCS 1800; Number of Samples for Testing

DCS 1800 SDCCH

(FER: 4.25 events/s, frame filling = 4/51)

Prop. cond.	Error rate	Stat. sign.	Indep. samples	Station. proc.	Samples:	Time: (s)
static	FER=0.10%	30 000	2	-	60 000	14 117.6
TU50	FER=9.0%	333	2	1 301	1 301	306.1
RA130	FER=8.0%	375	2	521	750	176.5
HT100	FER=13.0%	231	2	651	651	153.2
TU1.5	FER=22%	136	2	43 350	43 350	10 200.0
TU1.5(SFH)	FER=9.0%	333	2	43 350	43 350	10 200.0
TU50(SFH)	FER=9%	333	2	1 301	1 301	306.1
TI5	FER=13%	231	2	13 005	13 005	3 060

DCS 1800 RACH

(FER: 217 events/s, frame filling = 1)

Prop. cond.	Error rate	Stat. sign.	Indep. samples	Station. proc.	Samples:	Time: (s)
static	FER=0.50%	6 000	2	-	12 000	55.3
TU50	FER=13%	231	2	5 208	5 208	24.0
RA130	FER=12%	250	2	2 087	2 087	10.0
HT100	FER=13%	231	2	2 604	2 604	12.0
TU1.5	FER=15%	200	2	173 600	173 600	800.0
TU1.5(SFH)	FER=15%	200	2	173 600	173 600	800.0
TU50	FER=16%	188	2	5 208	5 208	24.0
RA130	FER=13%	231	2	2 087	2 087	10.0
TU50(SFH)	FER=13%	231	2	5 208	5 208	24.0
TI5	FER=13%	231	2	52 080	52 080	3063.5
TU50(SFH)	FER=16%	188	2	5208	5208	24
TI5	FER=16%	188	2	52 080	52 080	3063.5

DCS 1800 SACCH/T

(FER: 2.1 events/s, frame filling = 1/26)

Prop. cond.	Error rate	Stat. sign.	Indep. samples	Station. proc.	Samples:	Time: (s)
static	FER=0.10%	30 000	2	-	60 000	28 571.4
TU50	FER=9.0%	333	2	1 311	1 311	624.3
RA130	FER=8.0%	375	2	525	750	357.1
HT100	FER=13%	231	2	656	656	312.4
TU1.5	FER=22%	136	2	43 680	43 680	20 800.0
TU1.5(SFH)	FER=9.0%	333	2	43 680	43 680	20 800.0
TU50(SFH)	FER=9%	333	2	1 311	1 311	624.3
TI5	FER=13%	231	2	13 104	13 104	6 240.0

DCS 1800 SACCH/C

(FER: 2.13 events/s, frame filling = 4/102)

Prop. cond.	Error rate	Stat. sign.	Indep. samples	Station. proc.	Samples:	Time: (s)
static	FER=0.10%	30 000	2	-	60 000	28 169.0
TU50	FER=9%	333	2	1 304	1 304	612.2
RA130	FER=8.0%	375	2	523	750	352.1
HT100	FER=13%	251	2	652	652	306.1
TU1.5	FER=22%	136	2	43 452	43 452	20 400.0
TU1.5(SFH)	FER=9.0%	333	2	43 452	43 452	20 400.0
TU50(SFH)	FER=9%	333	2	1 304	1 304	612.2
TI5	FER=13%	231	2	26 071	26 071	12 240

DCS 1800 FACCH/F

(FER: 50 events/s, frame filling = 24/26)

Prop. cond.	Error rate	Stat. sign.	Indep. samples	Station. proc.	Samples:	Time: (s)
static	FER=0.10%	30 000	4	-	120 000	2 400.0
TU50	FER=3.9%	769	4	1 300	3 076	61.5
RA130	FER=3.4%	882	4	521	3 528	70.6
HT100	FER=7.4%	405	4	650	1 620	32.4
TU1.5	FER=22%	136	4	43 334	43 334	866.7
TU1.5(SFH)	FER=3.4%	882	4	43 334	43 334	866.7
TU50	FER=3.4%	882	4	1 300	3 528	70.6
RA130	FER=3.5%	857	4	521	3 428	68.6
TU50(SFH)	FER=3.9%	769	4	1 300	3 076	61.5
TI5	FER=8.0%	375	4	13 000	13 000	260.0
TU50(SFH)	FER=3.4%	882	4	1 300	3 528	70.6
TI5	FER=9.5%	316	4	13 000	13 000	260.0
TU50	FER=6.1%	492	4	1 300	1 968	39.4
TI5	FER=17.1%	176	4	13 000	13 000	260.0

DCS 1800 FACCH/H

(FER: 25 events/s, frame filling = 12/26)

Prop. cond.	Error rate	Stat. sign.	Indep. samples	Station. proc.	Samples:	Time: (s)
static	FER=0.10%	30 000	4	-	120 000	4 800.0
TU50	FER=7.2%	417	4	1 300	1 668	66.7
RA130	FER=5.7%	526	4	521	2 104	84.2
HT100	FER=10.4%	288	4	650	1 152	46.1
TU1.5	FER=22%	136	4	43 334	43 334	1733.4
TU1.5(SFH)	FER=6.7%	448	4	43 334	43 334	1733.4
TU50	FER=6.9%	435	4	1 300	1 740	69.6
TU50(SFH)	FER=7.2%	417	4	1 300	1 668	66.7
TI5	FER=6.9%	435	4	13 000	13 000	520.0
TU50(SFH)	FER=6.9%	435	4	1 300	1 740	69.6
TI5	FER=6.7%	448	4	13 000	13 000	520.0

DCS 1800 TCH/F9.6

(BER: 12000 events/s, frame filling = 24/26)

Prop. cond.	Error rate	Stat. sign.	Indep. samples	Station. proc.	Samples:	Time: (s)
static	BER=1.0E-5	3 000 000	10	-	30 000 000	2 500.0
TU50	BER=0.40%	7 500	10	312 000	312 000	26.0
RA130	BER=0.10%	30 000	10	125 000	300 000	25.0
HT100	BER=0.70%	4 286	10	156 000	156 000	13.0
TU1.5	BER=8.0%	375	10	10 400 000	10 400 000	866.7
TU1.5(SFH)	BER=0.30%	10 000	10	10 400 000	10 400 000	866.7
TU50	BER=0.80%	3 750	10	312 000	312 000	26.0
TU50 (SFH)	BER=0.3%	10 000	10	312 000	312 000	26.0
RA130	BER=0.20%	15 000	10	125 000	150 000	12.5
TU50(SFH)	BER=0.4%	7 500	10	312 000	312 000	26.0
TI5	BER=0.5%	6 000	10	3 120 000	3 120 000	260.0
TI5	BER=0.8%	3 750	10	3 120 000	3 120 000	260.0

DCS 1800 TCH/H4.8

(BER: 6000 events/s, frame filling = 12/26)

Prop. cond.	Error rate	Stat. sign.	Indep. samples	Station. proc.	Samples:	Time: (s)
static	BER=1.0E-5	3000 000	10	-	30000 000	5 000.0
TU50	BER=0.40%	7 500	10	312 000	312 000	52.0
RA130	BER=0.10%	30 000	10	125 000	300 000	50.0
HT100	BER=0.70%	4 286	10	156 000	156 000	26.0
TU1.5	BER=8.0%	375	10	10400 000	10400 000	1733.4
TU1.5(SFH)	BER=0.30%	10 000	10	10400 000	10400 000	1733.4
TU50	BER=0.80%	3 750	10	312 000	312 000	52.0
TU50(SFH)	BER=0.3%	10 000	10	312 000	312 000	52.0
RA130	BER=0.20%	15 000	10	125 000	150 000	25.0
TU50(SFH)	BER=0.40%	7 500	10	312 000	312 000	52.0
TI5	BER=0.50%	6 000	10	3 120 000	3 120 000	520.0
TI5	BER=0.80%	3 750	10	3 120 000	3 120 000	520.0

DCS 1800 TCH/F4.8

(BER: 6000 events/s, frame filling = 24/26)

Prop. cond.	Error rate	Stat. sign.	Indep. samples	Station. proc.	Samples:	Time: (s)
TU50	BER=1.0E-4	300 000	10	156 000	3000 000	500.0
RA130	BER=1.0E-4	300 000	10	62 500	3000 000	500.0
HT100	BER=1.0E-4	300 000	10	78 000	3000 000	500.0
TU1.5	BER=3.0%	1 000	10	5200 000	5200 000	866.7
TU1.5(SFH)	BER=1.0E-4	300 000	10	5200 000	5200 000	866.7
TU50(SFH)	BER=1.0E-4	300 000	10	1 560 000	3 000 000	260.0
TI5	BER=1.0E-4	300 000	10	1 560 000	3 000 000	260.0

DCS 1800 TCH/F2.4

(BER: 3600 events/s, frame filling = 24/26)

Prop. cond.	Error rate	Stat. sign.	Indep. samples	Station. proc.	Samples:	Time: (s)
TU50	BER=1.0E-5	3000 000	10	93 600	30000 000	8 333.3
RA130	BER=1.0E-5	3000 000	10	7 500	30000 000	8 333.3
HT100	BER=1.0E-5	3000 000	10	46 800	30000 000	8 333.3
TU1.5	BER=3.0%	1 000	10	3120 000	3120 000	866.7
TU1.5(SFH)	BER=1.0E-5	3000 000	10	3120 000	30000 000	8 333.3
TU50(SFH)	BER=1.0E-5	3000 000	10	93 600	30000 000	8 333.3
TI5	BER=2.0E-4	150 000	10	936 000	1 500 000	416.7
TI5	BER=1.0E-4	300 000	10	93 600	3 000 000	833.3

DCS 1800 TCH/H2.4

(BER: 3600 events/s, frame filling = 12/26)

Prop. cond.	Error rate	Stat. sign.	Indep. samples	Station. proc.	Samples:	Time: (s)
TU50	BER=1.0E-4	300 000	10	187 200	3000 000	833.3
RA130	BER=1.0E-4	300 000	10	75 000	3000 000	833.3
HT100	BER=1.0E-4	300 000	10	93 600	3000 000	833.3
TU1.5	BER=4.0%	750	10	6240 000	6240 000	1733.4
TU1.5(SFH)	BER=1.0E-4	300 000	10	6240 000	6240 000	1733.4
TU50(SFH)	BER=1.0E-4	300 000	10	187 200	3000 000	833.3
TI5	BER=1.0E-4	300 000	10	1 872 000	3 000 000	833.3
TI5	BER=2.0E-4	150 000	10	1 872 000	1 872 000	520.0

DCS 1800 TCH/FS

(FER: 50 events/s, RBER class Ib: 6600 events/s, RBER class II: 3900 events/s, frame filling = 24/26)

Prop. cond.	Error rate	Stat. sign.	Indep. samples	Station. proc	Samples:	Time: (s)
static	FER=0.10%	30 000	4	-	120 000	2 400.0
Ib	RBER=0.40%	7 500	10	-	75 000	11.4
II	RBER=2.0%	1 500	10	-	15 000	3.8
TU50	FER=3.0%	1000	4	1 300	4 000	80.0
Ib	RBER=0.30%	10 000	10	171 600	171 600	26.0
II	RBER=8.0%	375	10	101 400	101 400	26.0
RA130	FER=2.0%	1 500	4	521	6 000	120.0
Ib	RBER=0.20%	15 000	10	68 750	150 000	22.7
II	RBER=7.0%	429	10	40 625	40 625	10.4
HT100	FER=7.0%	429	4	650	1 716	34.3
Ib	RBER=0.50%	6 000	10	85 800	85 800	13.0
II	RBER=9.0%	333	10	50 700	50 700	13.0
TU1.5	FER=21%	143	4	43 334	43 334	866.7
Ib	RBER=2.0%	1 500	10	5720 000	5720 000	866.7
II	RBER=4.0%	750	10	3380 000	3380 000	866.7
TU1.5(SFH)	FER=3.0%	1 000	4	43 334	43 334	866.7
Ib	RBER=0.20%	15 000	10	5720 000	5730 000	866.7
II	RBER=8.0%	375	10	3380 000	3380 000	866.7
TU50	FER=3.0%	1 000	4	1 300	4 000	80.0
Ib	RBER=0.25%	12 500	10	171 600	171 600	26.0
II	RBER=8.1%	370	10	101 400	101 400	26.0
RA130	FER=3.0%	1 000	4	521	4 000	80.0
Ib	RBER=0.20%	15 000	10	71 500	150 000	22.7
II	RBER=8.0%	375	10	42 250	42 250	10.8
static II	RBER=1.0E-4	300 000	10	-	3000 000	769.2
EQU50	II RBER=3.0%	1 000	10	101 400	101 400	26.0
Static	FER=5%	600	4	-	2400	48.0
TU50(SFH)	FER=3.0%	1000	4	1 300	4 000	80.0
Ib	RBER=0.30%	10 000	10	171 600	171 600	26.0
II	RBER=8.0%	375	10	101 400	101 400	26.0
TI5	FER=6.0%	500	4	13 000	13 000	260.0
Ib	RBER=0.40%	7500	10	1 716 000	1 716 000	260.0
II	RBER=8.0%	375	10	1 014 000	1 014 000	260.0
TU50(SFH)	FER=3.0%	1000	4	1 300	4000	80.0
Ib	RBER=0.25%	12000	10	171 600	171 600	26.0
II	RBER=8.1%	370	10	101 400	101 400	26.0
TU50	FER=5.1%	588	4	1 300	2 352	47.0
Ib	RBER=0.45%	6667	10	171 600	171 600	26.0
II	RBER=8.9%	337	10	101 400	101 400	26.0
TI5	FER=10.2%	294	4	13 000	13 000	260.0
Ib	RBER=0.72%	4167	10	1 716 000	1 716 000	260.0
II	RBER=8.8%	341	10	1 014 000	1 014 000	260.0

GSM 1800 TCH/F14.4

(BER: 14500 events/s, frame filling = 24/26)

Prop. cond.	Error rate	Stat. sign.	Indep. Samples	Station. proc.	Samples:	Time: (s)
static	BER=1.0E-5	3 000 000	10	-	30 000 000	2 069.0
TU50	BER=2.1%	1 429	10	377 000	377 000	26.0
TU50(SFH)	BER=2.0%	1 500	10	377 000	377 000	26.0
RA130	BER=2.0%	1 500	10	150 800	150 800	10.4
HT100	BER=6.5%	462	10	188 500	188 500	13.0
TU1.5	BER=10.0%	300	10	12 566 667	12 566 667	866.7
TU1.5(SFH)	BER=3.0%	1 000	10	12 566 667	12 566 667	866.7
TU50	BER=4.0%	750	10	377 000	377 000	26.0
TU50(SFH)	BER=3.1%	968	10	377 000	377 000	26.0
RA130	BER=3.0%	1 000	10	150 800	150 800	10.4
TI5	BER=2.5%	1 200	10	3 770 000	3 770 000	260.0
TI5	BER=4.5%	667	10	3 770 000	3 770 000	260.0

DCS 1800 TCH/HS

(FER: 50 events/s, RBER class Ib: 3650 events/s, RBER class II: 850 events/s, frame filling = 12/26)

Prop. cond.	Error rate	Stat. sign.	Indep. samples	Station. proc	Samples:	Time: (s)
static (FER)	0.025%	120 000	4	-	480 000	9 600.0
Ib	0.001%	3 000 000	10	-	30 000 000	8 219.2
II	0.720%	4 167	10	-	41 667	49.0
TU50 (FER)	4.20%	714	4	2 600	2 857	57.1
Ib	0.38%	7 895	10	189 800	189 800	52.0
II	6.90%	435	10	44 200	44 200	52.0
RA130 (FER)	4.10%	732	4	1 040	2 927	58.5
Ib	0.28%	10 714	10	75 920	107 143	29.4
II	6.80%	441	10	17 680	17 680	20.8
HT100 (FER)	5.00%	600	4	1 300	2 400	48.0
Ib	0.63%	4 762	10	94 900	94 900	26.0
II	7.80%	385	10	22 100	22 100	26.0
TU1.5 (FER)	19.10%	157	4	86 667	86 667	1 733.3
Ib	0.52%	5 769	10	6 326 667	6 326 667	1 733.3
II	2.80%	1 071	10	1 473 333	1 473 333	1 733.3
TU50 (FER)	5.00%	600	4	2 600	2 600	52.0
Ib	0.29%	10 345	10	189 800	189 800	52.0
II	7.20%	417	10	44 200	44 200	52.0
RA130 (FER)	4.70%	638	4	1 040	2 553	51.1
Ib	0.21%	14 286	10	75 920	142 857	39.1
II	7.00%	429	10	17 680	17 680	20.8
TU50 (SFH) FER	4.20%	714	4	2 600	2 857	57.1
Ib	0.38%	7 895	10	189 800	189 800	52.0
II	6.90%	435	10	44 200	44 200	52.0
TI5 (FER)	4.10%	732	4	26 000	26 000	520.0
Ib	0.36%	8 333	10	1 898 000	1 898 000	520.0
II	6.90%	435	10	442 000	442 000	520.0
TU50 (SFH) FER	5.00%	600	4	2 600	2 600	52.0
Ib	0.29%	10 345	10	189 800	189 800	52.0
II	7.20%	417	10	44 200	44 200	52.0
TI5 (FER)	5.00%	600	4	26 000	26 000	520.0
Ib	0.29%	10 345	10	1 898 000	1 898 000	520.0
II	7.20%	417	10	442 000	442 000	520.0

To reduce the testing time on static FER and RBER class Ib the factor $k = P_b/P_s$ may be increased from $k = 2$ to $k > 2$ thus resulting in reasonable reductions of the test times, see table below. If this test fails, the test may be repeated with the number of samples given in the table above.

Prop. cond.	k = Pb/Ps	Stat. sign.	Indep. samples	Samples:	Time: (s)	Probability of no error (1 - p)
static (FER)	2.5	60 000	4	240 000	4800 (1h20')	6.8 %
lb	2.5	1 500 000	10	15 000 000	4110 (1h08')	6.8 %
static (FER)	3.0	40 000	4	160 000	2880 (48')	15.8 %
lb	3.0	1 000 000	10	10 000 000	2466 (41')	15.8 %

DCS 1800 TCH/EFS

(FER: 50 events/s, RBER class lb: 6600 events/s, RBER class II: 3900 events/s, frame filling = 24/26)

Prop. cond.	Error rate	Stat. sign.	Indep. samples	Station. proc.	Samples:	Time: (s)
Static	FER=0.10%	30 000	4	-	120 000	2 400.0
lb	RBER=0.10%	30 000	10	-	300 000	45.5
II	RBER=2.0%	1 500	10	-	15 000	3.8
TU50	FER=4.0%	750	4	1 300	3 000	60.0
lb	RBER=0.12%	25 000	10	171 600	250 000	37.9
II	RBER=8.0%	375	10	101 400	101 400	26.0
TU50 (SFH)	FER=4.0%	750	4	1 300	3 000	60.0
lb	RBER=0.12%	25 000	10	171 600	250 000	37.9
II	RBER=8.0%	375	10	101 400	101 400	26.0
RA130	FER=3.0%	1 000	4	520	4 000	80.0
lb	RBER=0.10%	30 000	10	68 640	300 000	45.5
II	RBER=7.0%	429	10	40 560	40 560	10.4
HT100	FER=7.0%	429	4	650	1 716	34.3
lb	RBER=0.24%	12 500	10	85 800	125 000	18.9
II	RBER=9.0%	333	10	50 700	50 700	13.0
TU1.5	FER=23.0%	130	4	43 334	43 334	866.7
lb	RBER=0.20%	15 000	10	5720 000	5720 000	866.7
II	RBER=3.0%	1 000	10	3380 000	3380 000	866.7
TU1.5(SFH)	FER=3.0%	1 000	4	43 334	43 334	866.7
lb	RBER=0.1%	30 000	10	5720 000	5720 000	866.7
II	RBER=8.0%	375	10	3380 000	3380 000	866.7
TU50	FER=3.0%	1 000	4	1 300	4 000	80.0
lb	RBER=0.10%	30 000	10	171 600	300 000	45.5
II	RBER=9.0%	333	10	101 400	101 400	26.0
TU50(SFH)	FER=3.0%	1 000	4	1 300	4 000	80.0
lb	RBER=0.10%	30 000	10	171 600	300 000	45.5
II	RBER=9.0%	1 000	10	101 400	101 400	26.0
RA130	FER=4.0%	750	4	520	3 000	60.0
lb	RBER=0.13%	23 077	10	68 640	300 000	45.5
II	RBER=8.0%	375	10	40 560	40 560	10.4
TI5	FER=8.0%	375	4	13 000	13 000	260.0
lb	RBER=0.21%	14 286	10	1 716 000	1 716 000	260.0
II	RBER=7.0%	429	10	1 014 000	1 014 000	260.0
TI5	FER=9.0%	333	4	13 000	13 000	260.0
lb	RBER=0.20%	15 000	10	1 716 000	1 716 000	260.0
II	RBER=7.0%	429	10	1 014 000	1 014 000	260.0

GSM 1800 TCH/AFS12.2

(FER: 50 events/s, RBER class Ib: 12200 events/s, frame filling = 24/26)

Prop. cond.	Error rate	Stat. sign.	Indep. samples	Station. proc.	Samples:	Time: (s)
Static (Ib)	RBER = 0,001 %	3000000	10	-	30000000	2459
TU50 (no SFH)	FER = 2 %	1500	4	1300	6000	120
Ib	RBER = 1,4 %	2142,9	10	317200	317200	26
TU50 (ideal SFH)	FER = 2 %	1500	4	1300	6000	120
Ib	RBER = 1,4 %	2142,9	10	317200	317200	26
RA130 (no SFH)	FER = 1,3 %	2307,7	4	520	9230,8	184,6
Ib	RBER = 1,2 %	2500	10	126880	126880	10,4
HT100 (no SFH)	FER = 4,6 %	652,2	4	650	2608,7	52,2
Ib	RBER = 2,1 %	1428,6	10	158600	158600	13
TI5 (no SFH)	FER = 4,9 %	612,2	4	13000	13000	260
Ib	RBER = 1,5 %	2000	10	3172000	3172000	260
TU1.5 (no SFH)	FER = 22 %	136,4	4	43333,3	43333,3	866,7
Ib	RBER = 0,92 %	3260,9	10	10573333,3	10573333,3	866,7
TU50 (no SFH)	FER = 2,7 %	1111,1	4	1300	4444,4	88,9
Ib	RBER = 1,6 %	1875	10	317200	317200	26
TU50 (ideal SFH)	FER = 2,7 %	1111,1	4	1300	4444,4	88,9
Ib	RBER = 1,6 %	1875	10	317200	317200	26
RA130 (no SFH)	FER = 1,8 %	1666,7	4	520	6666,7	133,3
Ib	RBER = 1,4 %	2142,9	10	126880	126880	10,4
TI5 (no SFH)	FER = 6 %	500	4	13000	13000	260
Ib	RBER = 1,7 %	1764,7	10	3172000	3172000	260

GSM 1800 TCH/AFS10.2

(FER: 50 events/s, RBER class Ib: 10200 events/s, frame filling = 24/26)

Prop. cond.	Error rate	Stat. sign.	Indep. samples	Station. proc.	Samples:	Time: (s)
Static (Ib)	RBER = 0,001 %	3000000	10	0	30000000	2941,2
TU50 (no SFH)	FER = 0,65 %	4615,4	4	1300	18461,5	369,2
Ib	RBER = 0,12 %	25000	10	265200	265200	26
TU50 (ideal SFH)	FER = 0,65 %	4615,4	4	1300	18461,5	369,2
Ib	RBER = 0,12 %	25000	10	265200	265200	26
RA130 (no SFH)	FER = 0,41 %	7317,1	4	520	29268,3	585,4
Ib	RBER = 0,084 %	35714,3	10	106080	357142,9	35
HT100 (no SFH)	FER = 1,6 %	1875	4	650	7500	150
Ib	RBER = 0,26 %	11538,5	10	132600	132600	13
TI5 (no SFH)	FER = 2,1 %	1428,6	4	13000	13000	260
Ib	RBER = 0,23 %	13043,5	10	2652000	2652000	260
TU1.5 (no SFH)	FER = 18 %	166,7	4	43333,3	43333,3	866,7
Ib	RBER = 0,54 %	5555,6	10	8840000	8840000	866,7
TU50 (no SFH)	FER = 0,98 %	3061,2	4	1300	12244,9	244,9
Ib	RBER = 0,17 %	17647,1	10	265200	265200	26
TU50 (ideal SFH)	FER = 0,98 %	3061,2	4	1300	12244,9	244,9
Ib	RBER = 0,17 %	17647,1	10	265200	265200	26
RA130 (no SFH)	FER = 0,56 %	5357,1	4	520	21428,6	428,6
Ib	RBER = 0,12 %	25000	10	106080	250000	24,5
TI5 (no SFH)	FER = 2,7 %	1111,1	4	13000	13000	260
Ib	RBER = 0,3 %	10000	10	2652000	2652000	260

GSM 1800 TCH/AFS7.95

(FER: 50 events/s, RBER class Ib: 7950 events/s, frame filling = 24/26)

Prop. cond.	Error rate	Stat. sign.	Indep. samples	Station. proc.	Samples:	Time: (s)
TU50 (no SFH)	FER = 0,025 %	120000	4	1300	480000	9600
Ib	RBER = 0,023 %	130434,8	10	206700	1304347,8	164,1
TU50 (ideal SFH)	FER = 0,025 %	120000	4	1300	480000	9600
Ib	RBER = 0,023 %	130434,8	10	206700	1304347,8	164,1
RA130 (no SFH)	FER = 0,018 %	166666,7	4	520	666666,7	13333,3
Ib	RBER = 0,016 %	187500	10	82680	1875000	235,8
HT100 (no SFH)	FER = 0,089 %	33707,9	4	650	134831,5	2696,6
Ib	RBER = 0,061 %	49180,3	10	103350	491803,3	61,9
TI5 (no SFH)	FER = 0,36 %	8333,3	4	13000	33333,3	666,7
Ib	RBER = 0,11 %	27272,7	10	2067000	2067000	260
TU1.5 (no SFH)	FER = 13 %	230,8	4	43333,3	43333,3	866,7
Ib	RBER = 0,67 %	4477,6	10	6890000	6890000	866,7
TU50 (no SFH)	FER = 0,07 %	42857,1	4	1300	171428,6	3428,6
Ib	RBER = 0,042 %	71428,6	10	206700	714285,7	89,8
TU50 (ideal SFH)	FER = 0,07 %	42857,1	4	1300	171428,6	3428,6
Ib	RBER = 0,042 %	71428,6	10	206700	714285,7	89,8
RA130 (no SFH)	FER = 0,029 %	103448,3	4	520	413793,1	8275,9
Ib	RBER = 0,03 %	100000	10	82680	1000000	125,8
TI5 (no SFH)	FER = 0,51 %	5882,4	4	13000	23529,4	470,6
Ib	RBER = 0,15 %	20000	10	2067000	2067000	260
TU1.5 (no SFH)	FER = 25 %	120	4	43333,3	43333,3	866,7
Ib	RBER = 1,2 %	2500	10	6890000	6890000	866,7
TU50 (no SFH)	FER = 2 %	1500	4	1300	6000	120
Ib	RBER = 0,68 %	4411,8	10	206700	206700	26
TU50 (ideal SFH)	FER = 2 %	1500	4	1300	6000	120
Ib	RBER = 0,68 %	4411,8	10	206700	206700	26
RA130 (no SFH)	FER = 1,2 %	2500	4	520	10000	200
Ib	RBER = 0,48 %	6250	10	82680	82680	10,4
TI5 (no SFH)	FER = 5,3 %	566	4	13000	13000	260
Ib	RBER = 1 %	3000	10	2067000	2067000	260

GSM 1800 TCH/AFS7.4

(FER: 50 events/s, RBER class Ib: 7400 events/s, frame filling = 24/26)

Prop. cond.	Error rate	Stat. sign.	Indep. samples	Station. proc.	Samples:	Time: (s)
TU50 (no SFH)	FER = 0,036 %	83333,3	4	1300	333333,3	6666,7
lb	RBER = 0,013 %	230769,2	10	192400	2307692,3	311,9
TU50 (ideal SFH)	FER = 0,036 %	83333,3	4	1300	333333,3	6666,7
lb	RBER = 0,013 %	230769,2	10	192400	2307692,3	311,9
RA130 (no SFH)	FER = 0,023 %	130434,8	4	520	521739,1	10434,8
lb	RBER = 0,007 %	428571,4	10	76960	4285714,3	579,2
HT100 (no SFH)	FER = 0,13 %	23076,9	4	650	92307,7	1846,2
lb	RBER = 0,031 %	96774,2	10	96200	967741,9	130,8
TI5 (no SFH)	FER = 0,41 %	7317,1	4	13000	29268,3	585,4
lb	RBER = 0,054 %	55555,6	10	1924000	1924000	260
TU1.5 (no SFH)	FER = 14 %	214,3	4	43333,3	43333,3	866,7
lb	RBER = 0,43 %	6976,7	10	6413333,3	6413333,3	866,7
TU50 (no SFH)	FER = 0,083 %	36144,6	4	1300	144578,3	2891,6
lb	RBER = 0,02 %	150000	10	192400	1500000	202,7
TU50 (ideal SFH)	FER = 0,083 %	36144,6	4	1300	144578,3	2891,6
lb	RBER = 0,02 %	150000	10	192400	1500000	202,7
RA130 (no SFH)	FER = 0,047 %	63829,8	4	520	255319,1	5106,4
lb	RBER = 0,012 %	250000	10	76960	2500000	337,8
TI5 (no SFH)	FER = 0,56 %	5357,1	4	13000	21428,6	428,6
lb	RBER = 0,072 %	41666,7	10	1924000	1924000	260
TU1.5 (no SFH)	FER = 26 %	115,4	4	43333,3	43333,3	866,7
lb	RBER = 0,8 %	3750	10	6413333,3	6413333,3	866,7
TU50 (no SFH)	FER = 2,3 %	1304,3	4	1300	5217,4	104,3
lb	RBER = 0,32 %	9375	10	192400	192400	26
TU50 (ideal SFH)	FER = 2,3 %	1304,3	4	1300	5217,4	104,3
lb	RBER = 0,32 %	9375	10	192400	192400	26
RA130 (no SFH)	FER = 1,4 %	2142,9	4	520	8571,4	171,4
lb	RBER = 0,22 %	13636,4	10	76960	136363,6	18,4
TI5 (no SFH)	FER = 5,4 %	555,6	4	13000	13000	260
lb	RBER = 0,52 %	5769,2	10	1924000	1924000	260

GSM 1800 TCH/AFS6.7

(FER: 50 events/s, RBER class Ib: 6700 events/s, frame filling = 24/26)

Prop. cond.	Error rate	Stat. sign.	Indep. samples	Station. proc.	Samples:	Time: (s)
TU50 (no SFH)	FER = 0,01 %	300000	4	1300	1200000	24000
Ib	RBER = 0,017 %	176470,6	10	174200	1764705,9	263,4
TU50 (ideal SFH)	FER = 0,01 %	300000	4	1300	1200000	24000
Ib	RBER = 0,017 %	176470,6	10	174200	1764705,9	263,4
RA130 (no SFH)	FER = 0,01 %	300000	4	520	1200000	24000
Ib	RBER = 0,01 %	300000	10	69680	3000000	447,8
HT100 (no SFH)	FER = 0,031 %	96774,2	4	650	387096,8	7741,9
Ib	RBER = 0,041 %	73170,7	10	87100	731707,3	109,2
TI5 (no SFH)	FER = 0,16 %	18750	4	13000	75000	1500
Ib	RBER = 0,082 %	36585,4	10	1742000	1742000	260
TU1.5 (no SFH)	FER = 11 %	272,7	4	43333,3	43333,3	866,7
Ib	RBER = 0,76 %	3947,4	10	5806666,7	5806666,7	866,7
TU50 (no SFH)	FER = 0,025 %	120000	4	1300	480000	9600
Ib	RBER = 0,028 %	107142,9	10	174200	1071428,6	159,9
TU50 (ideal SFH)	FER = 0,025 %	120000	4	1300	480000	9600
Ib	RBER = 0,028 %	107142,9	10	174200	1071428,6	159,9
RA130 (no SFH)	FER = 0,01 %	300000	4	520	1200000	24000
Ib	RBER = 0,016 %	187500	10	69680	1875000	279,9
TI5 (no SFH)	FER = 0,021 %	142857,1	4	13000	571428,6	11428,6
Ib	RBER = 0,11 %	27272,7	10	1742000	1742000	260
TU1.5 (no SFH)	FER = 22 %	136,4	4	43333,3	43333,3	866,7
Ib	RBER = 1,4 %	2142,9	10	5806666,7	5806666,7	866,7
TU50 (no SFH)	FER = 0,82 %	3658,5	4	1300	14634,1	292,7
Ib	RBER = 0,51 %	5882,4	10	174200	174200	26
TU50 (ideal SFH)	FER = 0,82 %	3658,5	4	1300	14634,1	292,7
Ib	RBER = 0,51 %	5882,4	10	174200	174200	26
RA130 (no SFH)	FER = 0,41 %	7317,1	4	520	29268,3	585,4
Ib	RBER = 0,34 %	8823,5	10	69680	88235,3	13,2
TI5 (no SFH)	FER = 2,9 %	1034,5	4	13000	13000	260
Ib	RBER = 0,86 %	3488,4	10	1742000	1742000	260

GSM 1800 TCH/AFS5.9

(FER: 50 events/s, RBER class Ib: 5900 events/s, frame filling = 24/26)

Prop. cond.	Error rate	Stat. sign.	Indep. samples	Station. proc.	Samples:	Time: (s)
TU50 (no SFH)	FER = 0,01 %	300000	4	1300	1200000	24000
Ib	RBER = 0,001 %	3000000	10	153400	3000000	5084,7
TU50 (ideal SFH)	FER = 0,01 %	300000	4	1300	1200000	24000
Ib	RBER = 0,001 %	3000000	10	153400	3000000	5084,7
RA130 (no SFH)	FER = 0,01 %	300000	4	520	1200000	24000
Ib	RBER = 0,001 %	3000000	10	61360	3000000	5084,7
HT100 (no SFH)	FER = 0,01 %	300000	4	650	1200000	24000
Ib	RBER = 0,002 %	1500000	10	76700	1500000	2542,4
TI5 (no SFH)	FER = 0,094 %	31914,9	4	13000	127659,6	2553,2
Ib	RBER = 0,014 %	214285,7	10	1534000	2142857,1	363,2
TU1.5 (no SFH)	FER = 10 %	300	4	43333,3	43333,3	866,7
Ib	RBER = 0,38 %	7894,7	10	5113333,3	5113333,3	866,7
TU50 (no SFH)	FER = 0,01 %	300000	4	1300	1200000	24000
Ib	RBER = 0,002 %	1500000	10	153400	1500000	2542,4
TU50 (ideal SFH)	FER = 0,01 %	300000	4	1300	1200000	24000
Ib	RBER = 0,002 %	1500000	10	153400	1500000	2542,4
RA130 (no SFH)	FER = 0,01 %	300000	4	520	1200000	24000
Ib	RBER = 0,001 %	3000000	10	61360	3000000	5084,7
TI5 (no SFH)	FER = 0,12 %	25000	4	13000	100000	2000
Ib	RBER = 0,022 %	136363,6	10	1534000	1534000	260
TU1.5 (no SFH)	FER = 21 %	142,9	4	43333,3	43333,3	866,7
Ib	RBER = 0,72 %	4166,7	10	5113333,3	5113333,3	866,7
TU50 (no SFH)	FER = 0,41 %	7317,1	4	1300	29268,3	585,4
Ib	RBER = 0,079 %	37974,7	10	153400	379746,8	64,4
TU50 (ideal SFH)	FER = 0,41 %	7317,1	4	1300	29268,3	585,4
Ib	RBER = 0,079 %	37974,7	10	153400	379746,8	64,4
RA130 (no SFH)	FER = 0,2 %	15000	4	520	60000	1200
Ib	RBER = 0,046 %	65217,4	10	61360	652173,9	110,5
TI5 (no SFH)	FER = 2 %	1500	4	13000	13000	260
Ib	RBER = 0,23 %	13043,5	10	1534000	1534000	260

GSM 1800 TCH/AFS5.15

(FER: 50 events/s, RBER class Ib: 5150 events/s, frame filling = 24/26)

Prop. cond.	Error rate	Stat. sign.	Indep. samples	Station. proc.	Samples:	Time: (s)
TU50 (no SFH)	FER = 0,01 %	300000	4	1300	1200000	24000
Ib	RBER = 0,001 %	3000000	10	133900	3000000	5825,2
TU50 (ideal SFH)	FER = 0,01 %	300000	4	1300	1200000	24000
Ib	RBER = 0,001 %	3000000	10	133900	3000000	5825,2
RA130 (no SFH)	-	-	4	520	-	-
Ib	RBER = 0,01 %	300000	10	53560	3000000	582,5
HT100 (no SFH)	FER = 0,004 %	750000	4	650	3000000	60000
Ib	RBER = 0,003 %	1000000	10	66950	10000000	1941,7
TI5 (no SFH)	FER = 0,07 %	42857,1	4	13000	171428,6	3428,6
Ib	RBER = 0,014 %	214285,7	10	1339000	2142857,1	416,1
TU1.5 (no SFH)	FER = 9,2 %	326,1	4	43333,3	43333,3	866,7
Ib	RBER = 0,45 %	6666,7	10	4463333,3	4463333,3	866,7
TU50 (no SFH)	FER = 0,01 %	300000	4	1300	1200000	24000
Ib	RBER = 0,001 %	3000000	10	133900	3000000	5825,2
TU50 (ideal SFH)	FER = 0,01 %	300000	4	1300	1200000	24000
Ib	RBER = 0,001 %	3000000	10	133900	3000000	5825,2
RA130 (no SFH)	FER = 0,01 %	300000	4	520	1200000	24000
Ib	RBER = 0,001 %	3000000	10	53560	3000000	5825,2
TI5 (no SFH)	FER = 0,081 %	37037	4	13000	148148,1	2963
Ib	RBER = 0,019 %	157894,7	10	1339000	1578947,4	306,6
TU1.5 (no SFH)	FER = 19 %	157,9	4	43333,3	43333,3	866,7
Ib	RBER = 0,84 %	3571,4	10	4463333,3	4463333,3	866,7
TU50 (no SFH)	FER = 0,26 %	11538,5	4	1300	46153,8	923,1
Ib	RBER = 0,072 %	41666,7	10	133900	416666,7	80,9
TU50 (ideal SFH)	FER = 0,26 %	11538,5	4	1300	46153,8	923,1
Ib	RBER = 0,072 %	41666,7	10	133900	416666,7	80,9
RA130 (no SFH)	FER = 0,13 %	23076,9	4	520	92307,7	1846,2
Ib	RBER = 0,038 %	78947,4	10	53560	789473,7	153,3
TI5 (no SFH)	FER = 1,4 %	2142,9	4	13000	13000	260
Ib	RBER = 0,22 %	13636,4	10	1339000	1339000	260

GSM 1800 TCH/AFS4.75

(FER: 50 events/s, RBER class Ib: 4750 events/s, frame filling = 24/26)

Prop. cond.	Error rate	Stat. sign.	Indep. samples	Station. proc.	Samples:	Time: (s)
TU50 (no SFH)	FER = 0,01 %	300000	4	1300	1200000	24000
lb	RBER = 0,001 %	3000000	10	123500	30000000	6315,8
TU50 (ideal SFH)	-	-	4	1300	-	-
lb	RBER = 0,001 %	3000000	10	123500	30000000	6315,8
RA130 (no SFH)	-	-	4	520	-	-
lb	RBER = 0,001 %	3000000	10	49400	30000000	6315,8
HT100 (no SFH)	FER = 0,01 %	300000	4	650	1200000	24000
lb	RBER = 0,001 %	3000000	10	61750	30000000	6315,8
TI5 (no SFH)	FER = 0,029 %	103448,3	4	13000	413793,1	8275,9
lb	RBER = 0,005 %	600000	10	1235000	6000000	1263,2
TU1.5 (no SFH)	FER = 7,9 %	379,7	4	43333,3	43333,3	866,7
lb	RBER = 0,31 %	9677,4	10	4116666,7	4116666,7	866,7
TU50 (no SFH)	FER = 0,01 %	300000	4	1300	1200000	24000
lb	RBER = 0,001 %	3000000	10	123500	30000000	6315,8
TU50 (ideal SFH)	FER = 0,01 %	300000	4	1300	1200000	24000
lb	RBER = 0,001 %	3000000	10	123500	30000000	6315,8
RA130 (no SFH)	-	-	4	520	-	-
lb	RBER = 0,001 %	3000000	10	49400	30000000	6315,8
TI5 (no SFH)	FER = 0,036 %	83333,3	4	13000	333333,3	6666,7
lb	RBER = 0,036 %	83333,3	10	1235000	1235000	260
TU1.5 (no SFH)	FER = 17 %	176,5	4	43333,3	43333,3	866,7
lb	RBER = 0,61 %	4918	10	4116666,7	4116666,7	866,7
TU50 (no SFH)	FER = 0,1 %	30000	4	1300	120000	2400
lb	RBER = 0,021 %	142857,1	10	123500	1428571,4	300,8
TU50 (ideal SFH)	FER = 0,1 %	30000	4	1300	120000	2400
lb	RBER = 0,021 %	142857,1	10	123500	1428571,4	300,8
RA130 (no SFH)	FER = 0,051 %	58823,5	4	520	235294,1	4705,9
lb	RBER = 0,009 %	333333,3	10	49400	3333333,3	701,8
TI5 (no SFH)	FER = 0,82 %	3658,5	4	13000	14634,1	292,7
lb	RBER = 0,11 %	27272,7	10	1235000	1235000	260

GSM 1800 TCH/AHS7.95

(FER: 50 events/s, RBER class Ib: 2800 events/s, RBER class II : 1800 events/s, frame filling = 12/26)

Prop. cond.	Error rate	Stat. sign.	Indep. samples	Station. proc.	Samples:	Time: (s)
Static	FER = 0,01 %	300000	4	-	1200000	24000
Ib	RBER = 0,004 %	750000	10	-	7500000	2678,6
II	RBER = 0,66 %	4545,5	10	-	45454,5	25,3
TU50 (no SFH)	FER = 20 %	150	4	2600	2600	52
Ib	RBER = 2,3 %	1304,3	10	145600	145600	52
II	RBER = 5 %	600	10	93600	93600	52
TU50 (ideal SFH)	FER = 20 %	150	4	2600	2600	52
Ib	RBER = 2,3 %	1304,3	10	145600	145600	52
II	RBER = 5 %	600	10	93600	93600	52
RA130 (no SFH)	FER = 17 %	176,5	4	1040	1040	20,8
Ib	RBER = 2 %	1500	10	58240	58240	20,8
II	RBER = 4,8 %	625	10	37440	37440	20,8
HT100 (no SFH)	FER = 27 %	111,1	4	1300	1300	26
Ib	RBER = 2,9 %	1034,5	10	72800	72800	26
II	RBER = 5,7 %	526,3	10	46800	46800	26
TI5 (no SFH)	FER = 20 %	150	4	26000	26000	520
Ib	RBER = 2,3 %	1304,3	10	1456000	1456000	520
II	RBER = 5 %	600	10	936000	936000	520
TU1.5 (no SFH)	FER = 27 %	111,1	4	86666,7	86666,7	1733,3
Ib	RBER = 0,85 %	3529,4	10	4853333,3	4853333,3	1733,3
II	RBER = 1,7 %	1764,7	10	3120000	3120000	1733,3
TU50 (no SFH)	FER = 23 %	130,4	4	2600	2600	52
Ib	RBER = 2,3 %	1304,3	10	145600	145600	52
II	RBER = 5,1 %	588,2	10	93600	93600	52
TU50 (ideal SFH)	FER = 23 %	130,4	4	2600	2600	52
Ib	RBER = 2,3 %	1304,3	10	145600	145600	52
II	RBER = 5,1 %	588,2	10	93600	93600	52
RA130 (no SFH)	FER = 20 %	150	4	1040	1040	20,8
Ib	RBER = 2,1 %	1428,6	10	58240	58240	20,8
II	RBER = 5,1 %	588,2	10	37440	37440	20,8
TI5 (no SFH)	FER = 22 %	136,4	4	26000	26000	520
Ib	RBER = 2,3 %	1304,3	10	1456000	1456000	520
II	RBER = 5,3 %	566	10	936000	936000	520
TU1.5 (no SFH)	FER = 14 %	214,3	4	86666,7	86666,7	1733,3
Ib	RBER = 0,49 %	6122,4	10	4853333,3	4853333,3	1733,3
II	RBER = 1 %	3000	10	3120000	3120000	1733,3
TU50 (no SFH)	FER = 6,7 %	447,8	4	2600	2600	52
Ib	RBER = 1 %	3000	10	145600	145600	52
II	RBER = 3,1 %	967,7	10	93600	93600	52
TU50 (ideal SFH)	FER = 6,7 %	447,8	4	2600	2600	52
Ib	RBER = 1 %	3000	10	145600	145600	52
II	RBER = 3,1 %	967,7	10	93600	93600	52
RA130 (no SFH)	FER = 6,5 %	461,5	4	1040	1846,2	36,9
Ib	RBER = 0,98 %	3061,2	10	58240	58240	20,8
II	RBER = 3,1 %	967,7	10	37440	37440	20,8
TI5 (no SFH)	FER = 6,7 %	447,8	4	26000	26000	520
Ib	RBER = 1 %	3000	10	1456000	1456000	520
II	RBER = 3,2 %	937,5	10	936000	936000	520

GSM 1800 TCH/AHS7.4

(FER: 50 events/s, RBER class Ib: 2950 events/s, RBER class II : 1400 events/s, frame filling = 12/26)

Prop. cond.	Error rate	Stat. sign.	Indep. samples	Station. proc.	Samples:	Time: (s)
Static	FER = 0,01 %	300000	4	-	1200000	24000
lb	RBER = 0,001 %	3000000	10	-	30000000	10169,5
II	RBER = 0,66 %	4545,5	10	-	45454,5	32,5
TU50 (no SFH)	FER = 16 %	187,5	4	2600	2600	52
lb	RBER = 1,4 %	2142,9	10	153400	153400	52
II	RBER = 5,3 %	566	10	72800	72800	52
TU50 (ideal SFH)	FER = 16 %	187,5	4	2600	2600	52
lb	RBER = 1,4 %	2142,9	10	153400	153400	52
II	RBER = 5,3 %	566	10	72800	72800	52
RA130 (no SFH)	FER = 13 %	230,8	4	1040	1040	20,8
lb	RBER = 1,1 %	2727,3	10	61360	61360	20,8
II	RBER = 5,1 %	588,2	10	29120	29120	20,8
HT100 (no SFH)	FER = 22 %	136,4	4	1300	1300	26
lb	RBER = 1,9 %	1578,9	10	76700	76700	26
II	RBER = 6 %	500	10	36400	36400	26
TI5 (no SFH)	FER = 16 %	187,5	4	26000	26000	520
lb	RBER = 1,4 %	2142,9	10	1534000	1534000	520
II	RBER = 5,3 %	566	10	728000	728000	520
TU1.5 (no SFH)	FER = 26 %	115,4	4	86666,7	86666,7	1733,3
lb	RBER = 0,69 %	4347,8	10	5113333,3	5113333,3	1733,3
II	RBER = 1,9 %	1578,9	10	2426666,7	2426666,7	1733,3
TU50 (no SFH)	FER = 18 %	166,7	4	2600	2600	52
lb	RBER = 1,4 %	2142,9	10	153400	153400	52
II	RBER = 5,5 %	545,5	10	72800	72800	52
TU50 (ideal SFH)	FER = 18 %	166,7	4	2600	2600	52
lb	RBER = 1,4 %	2142,9	10	153400	153400	52
II	RBER = 5,5 %	545,5	10	72800	72800	52
RA130 (no SFH)	FER = 16 %	187,5	4	1040	1040	20,8
lb	RBER = 1,3 %	2307,7	10	61360	61360	20,8
II	RBER = 5,4 %	555,6	10	29120	29120	20,8
TI5 (no SFH)	FER = 18 %	166,7	4	26000	26000	520
lb	RBER = 1,4 %	2142,9	10	1534000	1534000	520
II	RBER = 5,6 %	535,7	10	728000	728000	520
TU1.5 (no SFH)	FER = 13 %	230,8	4	86666,7	86666,7	1733,3
lb	RBER = 0,39 %	7692,3	10	5113333,3	5113333,3	1733,3
II	RBER = 1,2 %	2500	10	2426666,7	2426666,7	1733,3
TU50 (no SFH)	FER = 4,9 %	612,2	4	2600	2600	52
lb	RBER = 0,51 %	5882,4	10	153400	153400	52
II	RBER = 3,3 %	909,1	10	72800	72800	52
TU50 (ideal SFH)	FER = 4,9 %	612,2	4	2600	2600	52
lb	RBER = 0,51 %	5882,4	10	153400	153400	52
II	RBER = 3,3 %	909,1	10	72800	72800	52
RA130 (no SFH)	FER = 4,8 %	625	4	1040	2500	50
lb	RBER = 0,47 %	6383	10	61360	63829,8	21,6
II	RBER = 3,3 %	909,1	10	29120	29120	20,8
TI5 (no SFH)	FER = 5,1 %	588,2	4	26000	26000	520
lb	RBER = 0,51 %	5882,4	10	1534000	1534000	520
II	RBER = 3,3 %	909,1	10	728000	728000	520

GSM 1800 TCH/AHS6.7

(FER: 50 events/s, RBER class Ib: 2750 events/s, RBER class II : 1200 events/s, frame filling = 12/26)

Prop. cond.	Error rate	Stat. sign.	Indep. samples	Station. proc.	Samples:	Time: (s)
Static	FER = 0,01 %	300000	4	-	1200000	24000
Ib	RBER = 0,001 %	3000000	10	-	30000000	10909,1
II	RBER = 0,66 %	4545,5	10	-	45454,5	37,9
TU50 (no SFH)	FER = 9,4 %	319,1	4	2600	2600	52
Ib	RBER = 1,1 %	2727,3	10	143000	143000	52
II	RBER = 5,8 %	517,2	10	62400	62400	52
TU50 (ideal SFH)	FER = 9,4 %	319,1	4	2600	2600	52
Ib	RBER = 1,1 %	2727,3	10	143000	143000	52
II	RBER = 5,8 %	517,2	10	62400	62400	52
RA130 (no SFH)	FER = 7,5 %	400	4	1040	1600	32
Ib	RBER = 0,92 %	3260,9	10	57200	57200	20,8
II	RBER = 5,5 %	545,5	10	24960	24960	20,8
HT100 (no SFH)	FER = 13 %	230,8	4	1300	1300	26
Ib	RBER = 1,5 %	2000	10	71500	71500	26
II	RBER = 6,6 %	454,5	10	31200	31200	26
TI5 (no SFH)	FER = 9,2 %	326,1	4	26000	26000	520
Ib	RBER = 1,1 %	2727,3	10	1430000	1430000	520
II	RBER = 5,8 %	517,2	10	624000	624000	520
TU1.5 (no SFH)	FER = 23 %	130,4	4	86666,7	86666,7	1733,3
Ib	RBER = 0,71 %	4225,4	10	4766666,7	4766666,7	1733,3
II	RBER = 2,3 %	1304,3	10	2080000	2080000	1733,3
TU50 (no SFH)	FER = 12 %	250	4	2600	2600	52
Ib	RBER = 1,2 %	2500	10	143000	143000	52
II	RBER = 6 %	500	10	62400	62400	52
TU50 (ideal SFH)	FER = 12 %	250	4	2600	2600	52
Ib	RBER = 1,2 %	2500	10	143000	143000	52
II	RBER = 6 %	500	10	62400	62400	52
RA130 (no SFH)	FER = 9,9 %	303	4	1040	1212,1	24,2
Ib	RBER = 1 %	3000	10	57200	57200	20,8
II	RBER = 6 %	500	10	24960	24960	20,8
TI5 (no SFH)	FER = 11 %	272,7	4	26000	26000	520
Ib	RBER = 1,2 %	2500	10	1430000	1430000	520
II	RBER = 6,2 %	483,9	10	624000	624000	520
TU1.5 (no SFH)	FER = 11 %	272,7	4	86666,7	86666,7	1733,3
Ib	RBER = 0,39 %	7692,3	10	4766666,7	4766666,7	1733,3
II	RBER = 1,4 %	2142,9	10	2080000	2080000	1733,3
TU50 (no SFH)	FER = 2,5 %	1200	4	2600	4800	96
Ib	RBER = 0,38 %	7894,7	10	143000	143000	52
II	RBER = 3,5 %	857,1	10	62400	62400	52
TU50 (ideal SFH)	FER = 2,5 %	1200	4	2600	4800	96
Ib	RBER = 0,38 %	7894,7	10	143000	143000	52
II	RBER = 3,5 %	857,1	10	62400	62400	52
RA130 (no SFH)	FER = 2,5 %	1200	4	1040	4800	96
Ib	RBER = 0,37 %	8108,1	10	57200	81081,1	29,5
II	RBER = 3,5 %	857,1	10	24960	24960	20,8
TI5 (no SFH)	FER = 2,3 %	1304,3	4	26000	26000	520
Ib	RBER = 0,39 %	7692,3	10	1430000	1430000	520
II	RBER = 3,6 %	833,3	10	624000	624000	520

GSM 1800 TCH/AHS5.9

(FER: 50 events/s, RBER class Ib: 2350 events/s, RBER class II : 800 events/s, frame filling = 12/26)

Prop. cond.	Error rate	Stat. sign.	Indep. samples	Station. proc.	Samples:	Time: (s)
Static (II)	RBER = 0,66 %	4545,5	10	-	45454,5	56,8
TU50 (no SFH)	FER = 5,9 %	508,5	4	2600	2600	52
Ib	RBER = 0,52 %	5769,2	10	122200	122200	52
II	RBER = 6,1 %	491,8	10	41600	41600	52
TU50 (ideal SFH)	FER = 5,9 %	508,5	4	2600	2600	52
Ib	RBER = 0,52 %	5769,2	10	122200	122200	52
II	RBER = 6,1 %	491,8	10	41600	41600	52
RA130 (no SFH)	FER = 4,6 %	652,2	4	1040	2608,7	52,2
Ib	RBER = 0,39 %	7692,3	10	48880	76923,1	32,7
II	RBER = 5,8 %	517,2	10	16640	16640	20,8
HT100 (no SFH)	FER = 8,5 %	352,9	4	1300	1411,8	28,2
Ib	RBER = 0,72 %	4166,7	10	61100	61100	26
II	RBER = 6,8 %	441,2	10	20800	20800	26
TI5 (no SFH)	FER = 5,7 %	526,3	4	26000	26000	520
Ib	RBER = 0,51 %	5882,4	10	1222000	1222000	520
II	RBER = 6 %	500	10	416000	416000	520
TU1.5 (no SFH)	FER = 21 %	142,9	4	86666,7	86666,7	1733,3
Ib	RBER = 0,55 %	5454,5	10	4073333,3	4073333,3	1733,3
II	RBER = 2,6 %	1153,8	10	1386666,7	1386666,7	1733,3
TU50 (no SFH)	FER = 7,7 %	389,6	4	2600	2600	52
Ib	RBER = 0,6 %	5000	10	122200	122200	52
II	RBER = 6,4 %	468,8	10	41600	41600	52
TU50 (ideal SFH)	FER = 7,7 %	389,6	4	2600	2600	52
Ib	RBER = 0,6 %	5000	10	122200	122200	52
II	RBER = 6,4 %	468,8	10	41600	41600	52
RA130 (no SFH)	FER = 6,4 %	468,8	4	1040	1875	37,5
Ib	RBER = 0,48 %	6250	10	48880	62500	26,6
II	RBER = 6,3 %	476,2	10	16640	16640	20,8
TI5 (no SFH)	FER = 7,1 %	422,5	4	26000	26000	520
Ib	RBER = 0,57 %	5263,2	10	1222000	1222000	520
II	RBER = 6,5 %	461,5	10	416000	416000	520

GSM 1800 TCH/AHS5.15

(FER: 50 events/s, RBER class Ib: 2100 events/s, RBER class II : 600 events/s, frame filling = 12/26)

Prop. cond.	Error rate	Stat. sign.	Indep. samples	Station. proc.	Samples:	Time: (s)
Static (II)	RBER = 0,66 %	4545,5	10	-	45454,5	75,8
TU50 (no SFH)	FER = 2,6 %	1153,8	4	2600	4615,4	92,3
Ib	RBER = 0,53 %	5660,4	10	109200	109200	52
II	RBER = 6,3 %	476,2	10	31200	31200	52
TU50 (ideal SFH)	FER = 2,6 %	1153,8	4	2600	4615,4	92,3
Ib	RBER = 0,53 %	5660,4	10	109200	109200	52
II	RBER = 6,3 %	476,2	10	31200	31200	52
RA130 (no SFH)	FER = 2 %	1500	4	1040	6000	120
Ib	RBER = 0,4 %	7500	10	43680	75000	35,7
II	RBER = 6,1 %	491,8	10	12480	12480	20,8
HT100 (no SFH)	FER = 3,7 %	810,8	4	1300	3243,2	64,9
Ib	RBER = 0,76 %	3947,4	10	54600	54600	26
II	RBER = 7,2 %	416,7	10	15600	15600	26
TI5 (no SFH)	FER = 2,5 %	1200	4	26000	26000	520
Ib	RBER = 0,51 %	5882,4	10	1092000	1092000	520
II	RBER = 6,3 %	476,2	10	312000	312000	520
TU1.5 (no SFH)	FER = 17 %	176,5	4	86666,7	86666,7	1733,3
Ib	RBER = 0,8 %	3750	10	3640000	3640000	1733,3
II	RBER = 3,1 %	967,7	10	1040000	1040000	1733,3
TU50 (no SFH)	FER = 3,8 %	789,5	4	2600	3157,9	63,2
Ib	RBER = 0,66 %	4545,5	10	109200	109200	52
II	RBER = 6,8 %	441,2	10	31200	31200	52
TU50 (ideal SFH)	FER = 3,8 %	789,5	4	2600	3157,9	63,2
Ib	RBER = 0,66 %	4545,5	10	109200	109200	52
II	RBER = 6,8 %	441,2	10	31200	31200	52
RA130 (no SFH)	FER = 3,1 %	967,7	4	1040	3871	77,4
Ib	RBER = 0,53 %	5660,4	10	43680	56603,8	27
II	RBER = 6,6 %	454,5	10	12480	12480	20,8
TI5 (no SFH)	FER = 3,3 %	909,1	4	26000	26000	520
Ib	RBER = 0,6 %	5000	10	1092000	1092000	520
II	RBER = 6,9 %	434,8	10	312000	312000	520

GSM 1800 TCH/AHS4.75

(FER: 50 events/s, RBER class Ib: 2200 events/s, RBER class II : 600 events/s, frame filling = 12/26)

Prop. cond.	Error rate	Stat. sign.	Indep. samples	Station. proc.	Samples:	Time: (s)
Static (II)	RBER = 0,66 %	4545,5	10	-	45454,5	75,8
TU50 (no SFH)	FER = 1,2 %	2500	4	2600	10000	200
Ib	RBER = 0,18 %	16666,7	10	114400	166666,7	75,8
II	RBER = 6,5 %	461,5	10	31200	31200	52
TU50 (ideal SFH)	FER = 1,2 %	2500	4	2600	10000	200
Ib	RBER = 0,18 %	16666,7	10	114400	166666,7	75,8
II	RBER = 6,5 %	461,5	10	31200	31200	52
RA130 (no SFH)	FER = 1,1 %	2727,3	4	1040	10909,1	218,2
Ib	RBER = 0,13 %	23076,9	10	45760	230769,2	104,9
II	RBER = 6,2 %	483,9	10	12480	12480	20,8
HT100 (no SFH)	FER = 1,7 %	1764,7	4	1300	7058,8	141,2
Ib	RBER = 0,25 %	12000	10	57200	120000	54,5
II	RBER = 7,3 %	411	10	15600	15600	26
TI5 (no SFH)	FER = 1,2 %	2500	4	26000	26000	520
Ib	RBER = 0,17 %	17647,1	10	1144000	1144000	520
II	RBER = 6,4 %	468,8	10	312000	312000	520
TU1.5 (no SFH)	FER = 15 %	200	4	86666,7	86666,7	1733,3
Ib	RBER = 0,6 %	5000	10	3813333,3	3813333,3	1733,3
II	RBER = 3,6 %	833,3	10	1040000	1040000	1733,3
TU50 (no SFH)	FER = 2,1 %	1428,6	4	2600	5714,3	114,3
Ib	RBER = 0,25 %	12000	10	114400	120000	54,5
II	RBER = 7 %	428,6	10	31200	31200	52
TU50 (ideal SFH)	FER = 2,1 %	1428,6	4	2600	5714,3	114,3
Ib	RBER = 0,25 %	12000	10	114400	120000	54,5
II	RBER = 7 %	428,6	10	31200	31200	52
RA130 (no SFH)	FER = 1,8 %	1666,7	4	1040	6666,7	133,3
Ib	RBER = 0,19 %	15789,5	10	45760	157894,7	71,8
II	RBER = 6,8 %	441,2	10	12480	12480	20,8
TI5 (no SFH)	FER = 1,8 %	1666,7	4	26000	26000	520
Ib	RBER = 0,22 %	13636,4	10	1144000	1144000	520
II	RBER = 7 %	428,6	10	312000	312000	520

GSM 1800 PDTCH/CS-1 to CS-4

(BLER: 50 events/s, frame filling = 12/52)

Prop. cond.	Error rate	Stat. sign.	Indep. samples	Station. proc.	Samples:	Time: (s)
static	BLER=10%	300	2	-	600	12.0
TU50	BLER=10%	300	2	5 200	5 200	104.0
TU50 (SFH)	BLER=10%	300	2	5 200	5 200	104.0
RA130	BLER=10%	300	2	2 080	2 080	41.6
HT100	BLER=10%	300	2	2 600	2 600	52.0
TI5	BLER=10%	300	2	52 008	52 008	1 040.2
TU1.5	BLER=10%	300	2	173 360	173 360	3 467.2
TU1.5 (SFH)	BLER=10%	300	2	173 360	173 360	3 467.2

GSM 1800 PRACH (11 bits), PRACH (8 bits)

(BLER: 217 events/s, frame filling = 1)

Prop. cond.	Error rate	Stat. sign.	Indep. samples	Station. proc.	Samples:	Time: (s)
static	BLER=15%	200	2	-	400	8.0
TU50	BLER=15%	200	2	5 208	5 208	104.2
TU50 (SFH)	BLER=15%	200	2	5 208	5 208	104.2
RA130	BLER=15%	200	2	2 083	2 083	41.7
HT100	BLER=15%	200	2	2 604	2 604	52.1
TI5	BLER=15%	200	2	52 080	52 080	1 041.6
TU1.5	BLER=15%	200	2	173 600	173 600	3 472.0
TU1.5 (SFH)	BLER=15%	200	2	173 600	173 600	3 472.0

GSM 1800 PACCH

(BLER: 50 events/s, frame filling = 12/52)

Prop. cond.	Error rate	Stat. sign.	Indep. samples	Station. proc.	Samples:	Time: (s)
static	BLER=10%	300	2	-	600	12.0
TU50	BLER=10%	300	2	5 200	5 200	104.0
TU50 (SFH)	BLER=10%	300	2	5 200	5 200	104.0
RA130	BLER=10%	300	2	2 080	2 080	41.6
HT100	BLER=10%	300	2	2 600	2 600	52.0
TI5	BLER=10%	300	2	52 008	52 008	1 040.2
TU1.5	BLER=10%	300	2	173 360	173 360	3 467.2
TU1.5 (SFH)	BLER=10%	300	2	173 360	173 360	3 467.2

Annex D (informative): Change history

This annex lists all change requests approved for the present document since the first phase 2 version was approved by ETSI SMG.

SMG /GP#	SMG/GP tdoc	SMG8/G3 tdoc	VERS	CR	R	PH	CAT	SUBJECT	Resulting Version
S12	584/94		4.0.0	001		2	F	Amendments to GSM 11.21; revision of static and multipath reference sensitivity tests, and editorial changes	4.1.0
S13	99/95		4.1.0	002		2	F	Frequency range for E-GSM 900	4.2.0
	99/95		4.1.0	003		2	F	Types of implementation of frequency hopping	4.2.0
	99/95		4.1.0	004		2	F	Section 4.1.6.3, number of static power steps	4.2.0
	99/95		4.1.0	005		2	F	Spectrum due to modulation	4.2.0
	99/95		4.1.0	006		2	F	Intermodulation attenuation	4.2.0
	99/95		4.1.0	007		2	F	Definition of test environment for section 4.1.7.8	4.2.0
	99/95		4.1.0	009		2	D	Annex 2: Number of samples needed for statistical testing	4.2.0
S15	401/95		4.2.0	010		2	3	Reformatting	4.3.0
	401/95		4.2.0	011		2	1	new sections	4.3.0
	401/95		4.2.0	012		2	1	Splitting of conformance requirements	4.3.0
	401/95		4.2.0	013		2	1	Definition of extreme power supply conditions	4.3.0
	401/95		4.2.0	014		2	F	Corrections of inconsistencies	4.3.0
	401/95		4.2.0	015		2	3	Testing of reference interference	4.3.0
	401/95		4.2.0	016		2	1	Testing of reference sensitivity and interference	4.3.0
	401/95		4.2.0	017		2	1	Measurement BW for intermodulation attenuation tests	4.3.0
S16	566/95		4.3.0	018		2	1	Measurement uncertainties	4.4.0
	566/95		4.3.0	019		2	2	Mean transmitted RF carrier power	4.4.0
	566/95		4.3.0	020		2	1	Intermodulation attenuation	4.4.0
	566/95		4.3.0	021		2	2	Erroneous frame indication performance	4.4.0
	566/95		4.3.0	022		2	1	Reference sensitivity; testing of essential conformance	4.4.0
	566/95		4.3.0	023		2	1	AM suppression	4.4.0
	566/95		4.3.0	024		2	F	Measurement BW for transmitted RF carrier power vs time	4.4.0
	566/95		4.3.0	025		2	3	Editorial corrections and clarifications	4.4.0
S17	092/96		4.4.0	026		2	F	CR to GSM 11.21 section 7.5, Reference interference	4.5.0
	092/96		4.4.0	027		2	F	Testing of switching transients spectrum	4.5.0
	092/96		4.4.0	028		2	F	Measurement uncertainties	4.5.0
	092/96		4.4.0	029		2	F	BTS configurations	4.5.0
	092/96		4.4.0	030		2	F	Mean transmitted RF carrier power	4.5.0
	092/96		4.4.0	031		2	D	Configuration of BTS for section 6.2	4.5.0
	092/96		4.4.0	032		2	F	Testing of Multipath reference sensitivity with TU 50	4.5.0
	092/96		4.4.0	033		2	D	Section 6.4	4.5.0
S18	253/96		4.5.0	A034		2	F	Incorporation of technical PE comments	4.6.0
	265/96		4.5.0	A035		2	F	Correction of Tables for intermodulation limits in receive band	4.6.0
	253/96		4.5.0	A036		2	F	Incorporation of editorial and technical PE comments	4.6.0
	253/96		4.5.0	A037		2	F	Spectrum due to modulation and wideband noise: definition and correction	4.6.0
S20	606/96	52/96	4.6.0	A038		2	F	Correction of inconsistency with 05.05	4.7.0
	606/96	53/96	4.6.0	A039		2	F	Correction of statistical tables in informative annex	4.7.0
	627/96	29/96	4.6.0	A040		2	F	Maintenance of consistence with GSM 05.05	4.7.0
s22	348/97	006/97	4.7.1	A041		2	F	Deletion of TU3 and TU1.5 tests	5.0.0
	349/97		4.7.1	A049		2+	B	Definition of R-GSM band and the associated RF-parameters	5.0.0
s23	783/97	050/97	5.0.0	A051		R96	B	Addition of Radio Link Management chapter	5.1.0
	783/97	052/97	5.0.0	A053		R96	B	Testing BSS with ancillary FR amplifiers	5.1.0
	783/97	057/97	5.0.0	A055		R96	B	BSS using Antenna arrays	5.1.0
	783/97	064/97	5.0.0	A057		R96	B	Definition of EFR test cases	5.1.0
	783/97	061/97	5.0.0	A058		R96	B	Addition of 14.4 test case	5.1.0
	783/97	060/97	5.0.0	A059		R96	B	Conversion of phase 2+ TS to phase2 and 2+ EN	5.1.0
s25	98-0164	98p028	5.1.0	A060		R96	D	Conducted spurious emissions from the antenna connector	5.2.0
	98-0164	98p029	5.1.0	A061		R96	D	Intra BTS intermodulation attenuation	5.2.0
	98-0164	98p025	5.1.0	A062		R96	B	Definition of the number of samples required for TCH/HS	5.2.0
	98-0165	98p009	5.1.0	A063		R96	A	Measurement of average signal level through a multipath fading simulator	5.2.0
s26	98-394	98p035	5.2.0	A069		R96	F	Definition of timeslot to use for testing of Spectrum due to modulation, subclause 6.5.1.	5.3.0
	98-394	98p037	5.2.0	A070		R96	D	Environmental conditions during essential conformance	5.3.0

SMG /GP#	SMG/GP tdoc	SMG8/G3 tdoc	VERS	CR	R	PH	CAT	SUBJECT	Resulting Version
								testing	
	98-394	98p045	5.2.0	A071		R96	F	Ancillary RF amplifier	5.3.0
	98-394	98p054	5.2.0	A072		R96	B	New requirements for static layer 1 receiver functions	5.3.0
	98-441	98p058	5.2.0	A073		R96	F	Clarification of "relevant" and "operational" bands	5.3.0
	98-394	98p060	5.2.0	A075		R96	F	Resolution of PE comment SE3	5.3.0
	98-394	98p061	5.2.0	A076		R96	F	Resolution of PE comment UK2	5.3.0
s27	98-742	98p091	5.3.0	A077		R96	F	Addition to chap. 4.10.5 to define a BTS with separated antenna ports	5.4.0
	98-742	98p105	5.3.0	A079		R96	F	Reduction of Half Rate Speech (TCH/HS) number of samples to be tested as defined in Annex C1 and C2 for static FER and RBER class 1b.	5.4.0
	98-742	98p104	5.3.0	A082		R96	F	Erroneous frame indication performance	5.4.0
	98-742	98p098	5.3.0	A083		R96	D	Clarification on conformance requirements for testcases 6.7/6.8	5.4.0
s28	99-064	98p123	5.4.0	A085		R96	D	Spurious emissions from the receiver antenna connector	7.0.0
	99-064	98p126	5.4.0	A086		R96	A	Speeds for Multipath Fading profiles	7.0.0
	99-064	98p132	5.4.0	A087		R96	A	Multipath Reference Sensitivity Level	7.0.0
	99-064	98p139	5.4.0	A089		R96	A	Clarification on number of power steps	7.0.0
	99-064	98p134	5.4.0	A090		R96	A	Correction of multipath error performance limits	7.0.0
	99-064	98p137	5.4.0	A092		R97	B	GPRS Test Cases	7.0.0
	99-064	98p100	5.4.0	A095		R98	B	Pico-BTS requirements	7.0.0
	99-064	98p107	5.4.0	A096		R98	B	Pico-BTS requirements section 6.2.	7.0.0
s29	99-477	416/99	7.0.0	A099		R98		Correction regarding transmitter tests	7.1.0
	99-477	420/99	7.0.0	A101		R98		Removal of power levels in Watts in table 3	7.1.0
	99-477	418/99	7.0.0	A102	1	R98		Adding Pico requirements to GPRS sections	7.1.0
	99-477	491/99	7.0.0	A104		R98		Testing of BTSs that can be equipped with various configurations of antenna combiners	7.1.0
	99-477	528/99	7.0.0	A106		R98		Clarification on tests at extreme power supply	7.1.0
	99-477	614/99	7.0.0	A108		R98		Updates to annex A and C	7.1.0
s30	99-624	1372/99	7.1.0	A019	1	R98		Correction to Section 7.4 Multipath Reference Sensitivity	7.2.0
	99-624	1373/99	7.1.0	A113	1	R98		Clarification of Intra BSS intermodulation attenuation test purpose	7.2.0
	99-624	1378/99	7.1.0	A114	2	R98		Introduction of AMR requirements	7.2.0
	99-624	1245/99	7.1.0	A112		R98		C/I requirements for PicoBTS in GSM 1800	7.2.0
s30 b	99-810	1596/99	7.2.0	A118		R98		Correction of tables in sections 6.7, 6.8 for Pico BTS	8.0.0
	99-811	1938/99	7.2.0	A115	2	R99		Introduction of GSM 400, PCS 1900, MXM 850 and MXM 1900	8.0.0
	99-812	1935/99	7.2.0	A117	2	R99		Changes in clause 1- 6 due to EDGE introduction	8.0.0
s31	00-099	442/00	8.0.0	A119	2	R99		Modification EDGE TX test cases	8.1.0
	00-099	449/00	8.0.0	A120	2	R99		EDGE RX test cases	8.1.0
	00-099	481/00	8.0.0	A121	1	R99		Switching Transients for 8-PSK	8.1.0
s31 b	00-190	865/00	8.1.0	A122	1	R99		EDGE TX-test cases and uncertainties	8.2.0
	00-190	868/00	8.1.0	A123	1	R99		EDGE radio link management test cases	8.2.0
	00-191	532/00	8.1.0	A124		R99		Corrections of GSM 400 Spurious	8.2.0
	00-190	869/00	8.1.0	A125	2	R99		Changes in clause 7 due to EDGE and GSM850	8.2.0
s32	00-251	1208/00	8.2.0	A130		R99	B	Channels to be tested for AMR included	8.3.0
	00-252	1209/00	8.2.0	A126	2	R99	B	New subclause 9.4.4 Signal quality EGPRS	8.3.0
	00-252	974/00	8.2.0	A128		R99	C	Correction of acceptable measurement uncertainty	8.3.0
	00-252	1211/00	8.2.0	A129	1	R99	B	Missing values in table 19c	8.3.0
	00-259	1210/00	8.2.0	A127	2	R99	B	Spurious requirements in UMTS bands	8.3.0
GP1	GP-000365	GP-000365	8.3.0	A134	1	R99	F	Correction of Blocking and AM suppression test case in GSM11.21	8.4.0
	GP-000366	GP-000366	8.3.0	A131	1	R99	F	Changes in clause 7 due to EDGE and GSM05.01	8.4.0
	GP-000367	GP-000367	8.3.0	A132	1	R99	F	Correction of test case for Signal quality, EGPRS	8.4.0
	GP-000368	GP-000368	8.3.0	A133	1	R99	F	Correction of spurious requirements in UMTS bands	8.4.0
GP2	GP-000864	GP-000864	8.4.0	A135	1	R99	F	Modification of complete conformance, AM suppression	8.5.0
	GP-000515	GP-000515	8.4.0	A136		R99	F	Relaxation of PDTCH/CS-4 C/I requirements	8.5.0
	GP-000866	GP-000866	8.4.0	A137	2	R99	F	Additions to facilitate test on MXM systems	8.5.0
	GP-000525	GP-000525	8.4.0	A138		R99	F	Change of referenced specification for test site requirements for Radiated Spurious Emissions, Base Station testing	8.5.0
	GP-000865	GP-000865	8.4.0	A139	1	R99	F	BTS output power capability and requirements with 8PSK	8.5.0
GP4	GP-010480	GP-010480	8.5.0	A142		R99	F	Relaxation of Power versus time.	8.6.0
GP4	GP-010485	GP-010485	8.5.0	A147		R99	F	Correction of error parameter in Table 15	8.6.0
GP4	GP-010486	GP-010486	8.5.0	A148		R99	F	Testing of blocking requirements for MXM 1900 BTS	8.6.0
GP4	GP-010487	GP-010487	8.5.0	A149		R99	F	Alignment of AM suppression test for MXM 850/1900 normal BTS	8.6.0
GP4	GP-010901	GP-010901	8.5.0	A150	1	R99	F	Relaxed uncertainty for EVM	8.6.0

SMG /GP#	SMG/GP tdoc	SMG8/G3 tdoc	VERS	CR	R	PH	CAT	SUBJECT	Resulting Version
GP4	GP-010682	GP-010682	8.5.0	A141	1	R99	F	Intermodulation attenuation test method for MXM-850/1900 Systems	8.6.0
GP4	GP-010902	GP-010902	8.5.0	A143	1	R99	F	Correction of phase 2 references	8.6.0
GP4	GP-010483	GP-010483	8.5.0	A145		R99	F	Alternative testprocedure for vibration.	8.6.0

Change history							
Date	TSG GERAN#	TSG Doc.	CR	Rev	Subject/Comment	Old	New
2002-11	12	GP-023210	A153		Removal of clause 9.4.4	8.6.0	8.7.0
2002-11	12	GP-023415	A156		Correction of requirements for PDTCH/CS-4 C/lc	8.6.0	8.7.0
2003-02	13	GP-030413	A157	1	Correction to reference interference performance requirements	8.7.0	8.8.0
2003-06	15	GP-031699	A159	1	Clarification of requirements for BSS IM attenuation for GSM 850 and PCS 1900	8.8.0	8.9.0
2003-06	15	GP-031209	A161		Alignment of receiver requirements with TS 05.05	8.8.0	8.9.0
2005-11	27	GP-052812	A162	1	Performance requirements for E-TCH/F32.0	8.9.0	8.10.0
2009-05	42	GP-090799	A163		Correction to wanted signal level for testing of intermodulation characteristics	8.10.0	8.11.0