

Draft **ETSI EN 300 607-3** V9.0.0 (2000-06)

European Standard (Telecommunications series)

**Digital cellular telecommunications system;
Mobile Station (MS) conformance specification;
Part 3: Layer 3 Abstract Test Suite (ATS)
(GSM 11.10-3 version 9.0.0 Release 2000)**



GSM®
GLOBAL SYSTEM FOR
MOBILE COMMUNICATIONS

ETSI 

Reference

REN/SMG-071110Q9-3

Keywords

Digital cellular telecommunications system,
Global System for Mobile communications
(GSM)

ETSI

650 Route des Lucioles
F-06921 Sophia Antipolis Cedex - FRANCE

Tel.: +33 4 92 94 42 00 Fax: +33 4 93 65 47 16

Siret N° 348 623 562 00017 - NAF 742 C
Association à but non lucratif enregistrée à la
Sous-Préfecture de Grasse (06) N° 7803/88

Important notice

Individual copies of the present document can be downloaded from:

<http://www.etsi.org>

The present document may be made available in more than one electronic version or in print. In any case of existing or perceived difference in contents between such versions, the reference version is the Portable Document Format (PDF). In case of dispute, the reference shall be the printing on ETSI printers of the PDF version kept on a specific network drive within ETSI Secretariat.

Users of the present document should be aware that the document may be subject to revision or change of status. Information on the current status of this and other ETSI documents is available at <http://www.etsi.org/tb/status/>

If you find errors in the present document, send your comment to:
editor@etsi.fr

Copyright Notification

No part may be reproduced except as authorized by written permission.
The copyright and the foregoing restriction extend to reproduction in all media.

© European Telecommunications Standards Institute 2000.
All rights reserved.

Contents

Intellectual Property Rights.....	5
Foreword.....	5
1 Scope.....	7
2 References.....	7
3 Definitions and abbreviations.....	12
3.1 Definitions.....	12
3.2 Abbreviations.....	12
4 Test Suite Structure (TSS).....	12
4.1 Test suite naming convention.....	12
4.2 Suite Overview.....	13
4.3 Test groups.....	13
4.4 Test Step Structure.....	13
4.4.1 Preambles.....	13
4.4.2 Postambles.....	13
5 Test Purposes (TP).....	14
5.1 TP and test case naming convention.....	14
6 Abstract test method and test configurations.....	14
6.1 Test system model.....	14
6.2 Test Method.....	15
Annex A (normative): Partial IXIT proforma.....	16
A.0 Introduction.....	16
A.1 Identification Summary.....	17
A.2 Abstract Test Suite Summary.....	17
A.3 Test Laboratory.....	17
A.3.1 Test Laboratory Identification.....	17
A.3.2 Accreditation status of the test service.....	18
A.3.3 Manager of Test Laboratory.....	18
A.3.4 Contact person of Test Laboratory.....	18
A.3.5 Means of Testing.....	19
A.3.6 Instructions for Completion.....	20
A.4 Client.....	21
A.4.1 Client Identification.....	21
A.4.2 Client Test Manager.....	21
A.4.3 Client Contact person.....	21
A.4.4 Test Facilities Required.....	22
A.5 System Under Test.....	23
A.5.1 SUT Information.....	23
A.5.2 Limitations of the SUT.....	24
A.5.3 Environmental Conditions.....	25
A.6 Ancillary Protocols.....	26
A.6.1 Ancillary Protocols 1.....	26
A.6.2 Ancillary Protocols 2.....	26
A.7 Protocol Layer Information for L3 of Mobile Station.....	26
A.7.1 Information provided for test purposes by the MS supplier.....	26
A.7.2 MMI information.....	44

A.7.3	Test house specified parameters	52
Annex B (normative):	PCTR Proforma	86
	PROTOCOL Conformance Test Report (PCTR).....	86
Annex C (normative):	Layer 3 Abstract Test Suite	87
Annex D (normative):	Enhanced Full Rate Abstract Test Suite	88
Annex E (informative):	Cell Selection Abstract Test Suite	89
Annex F (informative):	Dual band Abstract Test Suite.....	90
Annex G (normative):	RGSM Abstract Test Suite.....	90
G.1	The TTCN Graphical form (TTCN.GR)	90
G.2	The TTCN Machine Processable form (TTCN.MP)	90
Annex H (normative):	ASCI Abstract Test Suite	91
H.1	The TTCN Graphical form (TTCN.GR)	91
H.2	The TTCN Machine Processable form (TTCN.MP)	91
History.....		92

Intellectual Property Rights

IPRs essential or potentially essential to the present document may have been declared to ETSI. The information pertaining to these essential IPRs, if any, is publicly available for **ETSI members and non-members**, and can be found in SR 000 314: "*Intellectual Property Rights (IPRs); Essential, or potentially Essential, IPRs notified to ETSI in respect of ETSI standards*", which is available from the ETSI Secretariat. Latest updates are available on the ETSI Web server (<http://www.etsi.org/ipr>).

Pursuant to the ETSI IPR Policy, no investigation, including IPR searches, has been carried out by ETSI. No guarantee can be given as to the existence of other IPRs not referenced in SR 000 314 (or the updates on the ETSI Web server) which are, or may be, or may become, essential to the present document.

Foreword

This European Standard (Telecommunications series) has been produced by ETSI Technical Committee Special Mobile Group (SMG), and is now submitted for the ETSI standards One-step Approval Procedure.

The present document describes the technical characteristics and methods of test for Mobile Stations (MSs), operating in the 900 MHz and 1 800 MHz frequency band (GSM 900 and DCS 1 800) within the digital cellular telecommunications system.

The present document corresponds to GSM technical specification GSM 11.10-3, covering the Digital cellular telecommunications system (Phase 2 and Phase 2+ Releases 96, 97, 98, 99, 00) version 9.0.0.

This part of the EN (Part 3), contains Tree and Tabular Combined Notation (TTCN) for Layer 3, cell selection, Enhanced Full Rate Speech, Multi-band, GSM-R band and ASCI service conformity specifications, for which Mobile Stations, within the digital cellular telecommunications system (Phase 2 and Phase 2+ Releases 96, 97, 98, 99, 00), are tested for compliance.

The contents of the present document may be subject to continuing work within SMG and may change following formal SMG approval. Should SMG modify the contents of the present document it will then be re-submitted for formal approval procedures by ETSI with an identifying change of release date and an increase in version number as follows:

Version 9.x.y

where:

- 9 GSM Phase2 and Phase 2+ Releases 96, 97, 98, 99, 00.
- x the second digit is incremented for changes of substance, i.e. technical enhancements, corrections, updates, etc.;
- y the third digit is incremented when editorial only changes have been incorporated in the specification.

The graphical form ATS

The electronic forms of the graphical representation (TTCN.GR format) corresponding to the ATSs for R-GSM and ASCI are contained in the Adobe Portable Document Format™ files rgsm-900.PDF (R-GSM) and asci-900.PDF (ASCI) which accompany the present document (Part 3) (these files are contained in archive en_30060703v090000o0.ZIP). The electronic forms of the graphical representation corresponding to the ATSs for the Layer 3, cell selection, Enhanced Full Rate Speech and Multi-band are referred to GSM 11.10-3 version 4.t.0.

The machine processable ATS

The electronic forms of the machine processable files (TTCN.MP format) corresponding to the ATS for Layer 3 are contained in the files rgsm-900.mp (R-GSM) and asci-900.mp (ASCI) which accompany the present document (Part 3) (these files are contained in archive en_30060703v090000o0.ZIP). The electronic forms of the machine processable files corresponding to the ATSs for the Layer 3, cell selection, Enhanced Full Rate Speech and Multi-band are referred to GSM 11.10-3 version 4.t.0.

EN 300 607 consists of four parts, which have the following EN numbers and titles:

- EN 300 607-1 Digital cellular telecommunications system;
Mobile Station (MS) conformance specification;
Part 1: Conformance specification
- Reference: GSM 11.10-1.
- EN 300 607-2 Digital cellular telecommunications system (Phase 2)
Mobile Station (MS) conformance specification;
Part 2: Protocol Implementation Conformance Statement (ICS)
proforma specification
- Reference: GSM 11.10-2.
- EN 300 607-3 Digital cellular telecommunications system;
Mobile Station (MS) conformance specification;
Part 3: Layer 3 Abstract Test Suites**
- Reference: GSM 11.10-3.**
- EN 300 607-4 Digital cellular telecommunications system (Phase 2+);
Mobile Station (MS) conformance specification;
Part 4: SIM application toolkit conformance specification
- Reference: GSM 11.10-4.

Proposed national transposition dates	
Date of latest announcement of this EN (doa):	3 months after ETSI publication
Date of latest publication of new National Standard or endorsement of this EN (dop/e):	6 months after doa
Date of withdrawal of any conflicting National Standard (dow):	6 months after doa

1 Scope

The present document specifies the Abstract Test Suites (ATS) and partial IXIT proforma for the Network Layer (Layer 3) at the mobile radio interface of the GSM or DCS (Phase 2+) mobile stations (MS) conforming to the ENs for Layer 3, cell selection, Enhanced Full Rate Speech, Multi-band, GSM-R band (R-GSM) and ASCE (the voice group call service (VGCS), voice broadcast service (VBS), enhanced Multi-Level Precedence and Pre-emption service (eMLPP), User-to-user Signalling (UUS) service and the Follow Me service) for the digital cellular telecommunications systems.

This EN is valid for MS implemented according Phase2 or Phase2+ R96, or R97, or R98, or R99, or R00.

The ISO standards for the methodology of conformance testing and the TTCN language are used as the basis for the test specifications.

2 References

The following documents contain provisions which, through reference in this text, constitute provisions of the present document.

- References are either specific (identified by date of publication, edition number, version number, etc.) or non-specific.
- For a specific reference, subsequent revisions do not apply.
- For a non-specific reference, the latest version applies.
- A non-specific reference to an ETS shall also be taken to refer to later versions published as an EN with the same number.
- For a Phase2+ Release 2000 MS, references to GSM documents are to version 9.x.y, when available.
- For a Phase2+ Release 1999 MS, references to GSM documents are to version 8.x.y, when available.
- For a Phase2+ Release 1998 MS, references to GSM documents are to version 7.x.y, when available.
- For a Phase2+ Release 1997 MS, references to GSM documents are to version 6.x.y, when available.
- For a Phase2+ Release 1996 MS, references to GSM documents are to version 5.x.y, when available.
- For a Phase2 MS, references to GSM documents are to version 4.x.y.

- [1] ISO/IEC 9646-1: "Information Technology-OSI- Conformance Testing Methodology and Framework, Part 1: General Concepts".
- [2] ISO/IEC 9646-2: "Information Technology-OSI- Conformance Testing Methodology and Framework, Part 2: Abstract Test Suite Specification".
- [3] ISO/IEC 9646-3: "Information Technology-OSI- Conformance Testing Methodology and Framework, Part 3: The Tree and Tabular Combined Notation".
- [4] ISO/IEC 9646-5: "Information Technology-OSI- Conformance Testing Methodology and Framework, Part 5: Requirements on test laboratories and clients for the conformance assessment process".
- [5] ISO/IEC 8824: "Information Technology-OSI- Specification of Abstract Syntax Notation One (ASN.1)".
- [6] ISO/IEC 8825: "Information Technology-OSI- Specification of Basic Encoding Rules for Abstract Syntax Notation One (ASN.1)".
- [7] ITU-T Recommendation Q.773: "Specifications of Signalling System No.7; Transaction capabilities formats and encoding".

- [8] ETS 300 287: "Integrated Services Digital Network (ISDN); Signalling System No.7, Transaction Capabilities Application Part (TCAP) version 2".
- [9] ETS 300 406 (January 1995): "Methods for Testing and Specification (MTS); Protocol and profile conformance testing specifications; Standardization methodology".
- [10] GSM 02.02: "Digital cellular telecommunication system (see Note 1); Bearer Services (BS) supported by a GSM Public Land Mobile Network (PLMN)".
- [10a] 3G TS 22.002: "Circuit Bearer Services (BS) supported by a Public Land Mobile Network (PLMN) (see Note 2)"
- [11] GSM 02.03: "Digital cellular telecommunication system (see Note 1); Teleservices supported by a GSM Public Land Mobile Network (PLMN)".
- [11a] 3G TS 22.003: "Circuit Teleservices supported by a Public Land Mobile Network (PLMN) (see Note 2)"
- [12] GSM 02.06: "Digital cellular telecommunication system (see Note 1); Types of Mobile Stations (MS)".
- [13] GSM 02.07: "Digital cellular telecommunication system (see Note 1); Mobile Station (MS) features".
- [14] GSM 02.30: "Digital cellular telecommunication system (see Note 1); Man-Machine Interface (MMI) of the Mobile Station (MS)".
- [14a] 3G TS 22.030: "Man-Machine Interface (MMI) of the User Equipment (UE) (see Note 2)"
- [15] GSM 02.67: "Digital cellular telecommunications system (Phase 2+); enhanced Multi-Level Precedence and Pre-emption service (eMLPP) – stage 1"
- [15a] 3G TS 22.067: "Enhanced Multi-Level Precedence and Pre-emption service (eMLPP) - Stage 1 (see Note 2)"
- [16] GSM 02.68: "Digital cellular telecommunications system (Phase 2+); Voice Group Call Service – stage 1"
- [17] GSM 02.69: "Digital cellular telecommunications system (Phase 2+); Voice Broadcast Service – stage 1"
- [18] GSM 03.03: "Digital cellular telecommunication system (see Note 1); Numbering, addressing and identification".
- [18a] 3G TS 23.003: "Numbering, Addressing and Identification (see Note 2)"
- [19] GSM 03.09: "Digital cellular telecommunications system (see Note 1); Handover procedures".
- [19a] 3G TS 23.009: "Handover procedures (see Note 2)"
- [20] GSM 03.10: "Digital cellular telecommunications system (see Note 1); GSM Public Land Mobile Network (PLMN) connection types".
- [21] GSM 03.11: "Digital cellular telecommunication system (see Note 1); Technical realization of supplementary services".
- [21a] 3G TS 23.011 "Technical Realization of Supplementary Services – General aspects (see Note 2)"
- [22] GSM 03.12: "Digital cellular telecommunications system (see Note 1); Location registration procedures".
- [22a] 3G TS 23.012 "Location management procedures (see Note 2)"
- [23] GSM 03.14: "Digital cellular telecommunications system (see Note 1); Support of Dual Tone Multi-Frequency signalling (DTMF) via the GSM system".

- [23a] 3G TS 23.014: "Support of Dual Tone Multi Frequency (DTMF) signalling (see Note 2)"
- [24] GSM 03.22: "Digital cellular telecommunication system (see Note 1); Functions related to Mobile Station (MS) in idle mode".
- [25] GSM 03.40: "Digital cellular telecommunication system (see Note 1); Technical realization of the Short Message Service (SMS) Point to Point (PP)".
- [25a] 3G TS 23.040: "Technical realization of Short Message Service (see Note 2)"
- [26] GSM 03.41: "Digital cellular telecommunication system (see Note 1); Technical realization of Short Message Service Cell Broadcast (SMSCB)".
- [26a] 3G TS 23.041: "Technical realization of Cell Broadcast service (see Note 2)"
- [27] GSM 03.67: "Digital cellular telecommunications system (Phase 2+); enhanced Multi-Level Precedence and Pre-emption service (eMLPP) – stage 2"
- [27a] 3G TS 23.067: "Enhanced Multi-level precedence and Pre-emption service (eMLPP) – Stage 2 (see Note 2)"
- [28] GSM 03.68: "Digital cellular telecommunications system (Phase 2+); Voice Group Call Service – stage 2"
- [29] GSM 03.69: "Digital cellular telecommunications system (Phase 2+); Voice Broadcast Service – stage 2"
- [30] GSM 04.01: "Digital cellular telecommunications system (see Note 1); Mobile Station - Base Station System (MS - BSS) interface General aspects and principles".
- [31] GSM 04.03: "Digital cellular telecommunications system (see Note 1); Mobile Station - Base Station System (MS - BSS) interface Channel structures and access capabilities".
- [32] GSM 04.04: "Digital cellular telecommunication system (see Note 1); layer 1 General requirements".
- [33] GSM 04.05: "Digital cellular telecommunication system (see Note 1); Data Link (DL) layer General aspects".
- [34] GSM 04.06: "Digital cellular telecommunication system (see Note 1); Mobile Station - Base Station System (MS - BSS) interface Data Link (DL) layer specification".
- [35] GSM 04.07: "Digital cellular telecommunication system (see Note 1); Mobile radio interface signalling layer 3 General aspects".
- [35a] 3G TS 24.007: "Mobile Radio Interface Signalling Layer 3 – general Aspects (see Note 2)"
- [36] GSM 04.08: "Digital cellular telecommunication system (see Note 1); Mobile radio interface layer 3 specification".
- [36a] 3G TS 24.008: "Mobile radion interface Layer 3 specification; Core network Protocols – Stage 3 (see Note 2)"
- [37] GSM 04.10: "Digital cellular telecommunication system (see Note 1); Mobile radio interface layer 3 Supplementary services specification General aspects".
- [37a] 3G TS 24.010: "Mobile radio Interface Layer 3 – Supplementary Services Specification – General Aspects (see Note 2)"
- [38] GSM 04.11: "Digital cellular telecommunication system (see Note 1); Point-to-Point (PP) Short Message Service (SMS) support on mobile radio interface".
- [38a] 3G TS 24.011: "Point-to-Point (PP) Short Message Service (SMS) Support on Mobile Radio Interface (see Note 2)"

- [39] GSM 04.12: "Digital cellular telecommunication system (see Note 1); Short Message Service Cell Broadcast (SMSCB) support on the mobile radio interface".
- [39a] 3G TS 24.012: "Short Message Service Cell Broadcast (SMSCB) Support on the Mobile Radio interface (see Note 2)"
- [40] GSM 04.67: "Digital cellular telecommunications system (Phase 2+); enhanced Multi-Level Precedence and Pre-emption service (eMLPP) Stage 3"
- [40a] 3G TS 24.067: "Enhanced Multi-level Precedence and Pre-emption service (eMLPP) – stage 3 (see Note 2)"
- [41] GSM 04.68: "Digital cellular telecommunications system (Phase 2+); Group Call Control (GCC) protocol
- [42] GSM 04.69: "Digital cellular telecommunications system (Phase 2+); Broadcast Call Control (BCC) protocol
- [43] GSM 04.80: "Digital cellular telecommunication system (see Note 1); Mobile radio interface layer 3 supplementary services specification; Formats and coding".
- [43a] 3G TS 24.080: "Mobile Radio Layer 3 Supplementary Service specification – Formats and coding (see Note 2)"
- [44] GSM 04.81: "Digital cellular telecommunication system (see Note 1); Line identification supplementary services - Stage 3".
- [44a] 3G TS 24.081: "Line identification Supplementary Service – Stage 3 (see Note 2)"
- [45] GSM 04.82: "Digital cellular telecommunication system (see Note 1); Call Forwarding (CF) supplementary services - Stage 3".
- [45a] 3G TS 24.082: "Call Forwarding Supplementary Service – Stage 3 (see Note 2)"
- [46] GSM 04.83: "Digital cellular telecommunication system (see Note 1); Call Waiting (CW) and Call Hold (HOLD) supplementary services - Stage 3".
- [46a] 3G TS 24.083: "Call Waiting (CW) and Call Hold (HOLD) Supplementary Service – Stage 3 (see Note 2)"
- [47] GSM 04.84: "Digital cellular telecommunication system (see Note 1); MultiParty (MPTY) supplementary services - Stage 3".
- [47a] 3G TS 24.084: "Multiparty (MPTY) Supplementary Service – stage 3 (see Note 2)"
- [48] GSM 04.85: "Digital cellular telecommunications system (see Note 1); Closed User Group (CUG) supplementary services - Stage 3".
- [48a] 3G TS 24.085: "Closed User Group (CUG) Supplementary Service – Stage 3 (see Note 2)"
- [49] GSM 04.86: "Digital cellular telecommunication system (see Note 1); Advice of Charge (AoC) supplementary services - Stage 3".
- [49a] 3G TS 24.086: "Advice of Charge (AoC) Supplementary Service – Stage 3 (see Note 2)"
- [50] GSM 04.88: "Digital cellular telecommunication system (see Note 1); Call Barring (CB) supplementary services - Stage 3".
- [50a] 3G TS 24.088: "Call Barring (CB) Supplementary Service – Stage 3 (see Note 2)"
- [51] GSM 04.90: "Digital cellular telecommunication system (see Note 1); Unstructured supplementary services operation - Stage 3".
- [51a] 3G TS 24.090: "Unstructured Supplementary Service Data (USSD) – Stage 3 (see Note 2)"

- [52] GSM 05.01: "Digital cellular telecommunications system (see Note 1); Physical layer on the radio path General description".
- [53] GSM 05.02: "Digital cellular telecommunication system (see Note 1); Multiplexing and multiple access on the radio path".
- [54] GSM 05.03: "Digital cellular telecommunication system (see Note 1); Channel coding".
- [55] GSM 05.04: "Digital cellular telecommunication system (see Note 1); Modulation".
- [56] GSM 05.05: "Digital cellular telecommunication system (see Note 1); Radio transmission and reception".
- [57] GSM 05.08: "Digital cellular telecommunication system (see Note 1); Radio subsystem link control".
- [58] GSM 05.10: "Digital cellular telecommunication system (see Note 1); Radio subsystem synchronization".
- [59] GSM 07.01: "Digital cellular telecommunication system (see Note 1); General on Terminal Adaptation Functions (TAF) for Mobile Stations (MS)".
- [59a] 3G TS 27.001: "General on Terminal Adaptation Functions (TAF) for Mobile stations (MS) (see Note 2)"
- [60] GSM 08.08: "Digital cellular telecommunications system (see Note 1); Mobile-services Switching Centre - Base Station System (MSC - BSS) interface Layer 3 specification".
- [61] GSM 08.58: "Digital cellular telecommunications system (see Note 1); Base Station Controller - Base Transceiver Station (BSC - BTS) interface Layer 3 specification".
- [62] GSM 09.02: "Digital cellular telecommunication system (see Note 1); Mobile Application Part (MAP) specification".
- [62a] 3G TS 29.002: "Mobile Application Part (MAP) (see Note 2)"
- [63] GSM 11.10-1 Version 9.0.0: "Digital cellular telecommunications system (); Mobile Station (MS) conformance specification; Part 1: Conformance specification".
- [64] GSM 11.10-2: "Digital cellular telecommunications system (see Note 1); Mobile Station (MS) conformance specification; Part 2: Protocol Implementation Conformance Statement (PICS) Proforma specification".
- [65] GSM 11.11: "Digital cellular telecommunications system (see Note 1); Mobile Equipment (SIM - ME) interface".
- [66] 3G TS 22.087: "User-to-User Signalling (UUS); Service description, Stage 1 (see Note 2)".
- [67] 3G TS 22.094: "Follow Me Service description; Stage 1 (see Note 2)".
- [68] 3G TS 23.087: "User-to-User Signalling (UUS) Supplementary Service; Stage 2 (see Note 2)".
- [69] 3G TS 23.094: "Follow-Me (FM) - Stage 2 (see Note 2)".
- [70] 3G TS 24.087: "User-to-User Signalling (UUS) Supplementary Service; Stage 3 (see Note 2)".
- [71] GSM 04.18: "Radio Resource Control Protocol (see Note 1)"

Note 1: Read Phase 2 or Phase 2+ as necessary.

Note 2: Read Release 1999 or further as necessary

3 Definitions and abbreviations

3.1 Definitions

For the purposes of the present document, the following terms and definitions apply:

Abstract Test Suite (ATS): refer to ISO/IEC 9646-1 [1].

Implementation Under Test (IUT): refer to ISO/IEC 9646-1 [1].

Partial Protocol Implementation eXtra Information for Testing (IXIT): refer to ISO/IEC 9646-1 [1].

Point of Controls and Observations (PCO): refer to ISO/IEC 9646-1 [1].

Protocol Implementation Conformance Statement (ICS): refer to ISO/IEC 9646-1 [1].

System Under Test (SUT): refer to ISO/IEC 9646-1 [1].

3.2 Abbreviations

For the purposes of the present document, the following abbreviations apply:

ATS	Abstract Test Suite
BI	Invalid Behaviour tests
BO	Inopportune Behaviour tests
BV	Valid Behaviour tests
CA	CAbility tests
EDP-N	Event Detection Point - Notification
EDP-R	Event Detection Point - Request
EN	European Telecommunication Standard
FE	Functional Entity
FSM	Finite State Machine
ICS	Implementation Conformance Statement
IUT	Implementation Under Test
IXIT	Implementation eXtra Information for Testing
PDU	Protocol Data Unit
SUT	System Under Test
TP	Test Purpose
TSS	Test Suite Structure

4 Test Suite Structure (TSS)

4.1 Test suite naming convention

The test group identifier for each group and subgroup is built according to the scheme in figure 1.

Identifier: L3<c><g>

<c> = category:	RGSM	R-GSM test suite
	ASCI	ASCI test suite
	L3	Layer 3
	EFR	Enhanced Full Rate
	DB	Dual Band
	CS	Cell Selection

<g> = group:	eMLPP	eMLPP test group
	VGCS_VBS	VGCS/VBS test group
	CellSelection	cell selection and re-selection test group
	Signalling	signalling test group
	UUS	User-to-User signalling test group
	FM	Follow Me test group
	General	General cases
	Initial Test	Initial test
	IdleMode	Idle Mode
	BiBo	Invalid and Inopportune Behaviour test
	RR	Radio Ressource
	MM	Mobility Management
	CC	Call Control
	StructureProc	Structure procedure
	EGSMSignalling	EGSM Signalling
	SS	Supplementary Service
	SMS	Short Message Service
	EFR	Enhanced Full Rate
	MultiBandMsRpt	Multi Band MS Report
	DualBand	Dual Band

Figure 1: Test group identifier naming convention scheme

4.2 Suite Overview

Figure 2 shows the structure of the test suites in the present document.

ATSs					
L3 Phase 2	CS Phase 2	EFR Phase 2	DB Phase 2	RGSM R96	ASCI R96
					UUS & FM R00

Figure 2: Test suite structure of the L3 tests

4.3 Test groups

Each test group corresponds to a subclause in the GSM 11.10-1.

4.4 Test Step Structure

4.4.1 Preambles

The preamble is defined for each test case.

4.4.2 Postambles

After each test case the IUT shall be brought to the state as defined in the postamble for each test case.

5 Test Purposes (TP)

For each conformance requirement a Test Purpose (TP) is defined. The test purposes are specified in the ATS Dynamic part (annex A and C).

5.1 TP and test case naming convention

In order clearly to map the conformance requirements specified in the EN 300 607-1 and TTCN test cases in the ATS, the clause numbers in the EN 300 607-1 are used as test case names.

The identifier of each TP is identical to the name of the implemented TTCN test case.

"Test Purpose Identifier" = "Test Case Name" = TPI = TC_NN_A_B_C_D_E, where NN, A, B, C, D and E are digits used in the corresponding clause numbers of EN 300 607-1. For example, the test case name TC_26_14_1_2 is the TTCN specification corresponding to the conformance requirements and the test case in the clause 26.14.1.2 in the EN 300 607-1. TC_26_10_2_1R is the TTCN specification corresponding to the conformance requirements and the test case of the R-GSM part in the clause 26.10.2.1 in the EN 300 607-1.

In case where the clause has been implemented in more than one test case sub numbering has been introduced..

6 Abstract test method and test configurations

The distributed test method applies to the L3 MS testing. The test method uses a lower tester and a Man-Machine Interface (MMI) as an upper tester at the SUT.

6.1 Test system model

The model of the L3 test system is based on the original protocol architecture at the air interface. The test system consists conceptually of a lower tester LT, the L3 test programme (executable test suite), a L2 radio link emulator, a management functional unit, the L1 service provider and a TRx set (see figure 1).

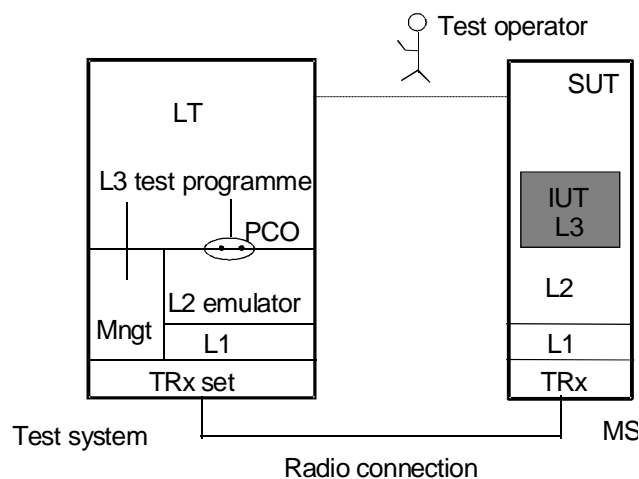

Figure 3: Test system and distributed test method

The LT provides the test environment and for test execution and the means of control and observation at the L3 lower service boundary within the test system.

The L3 TTCN test specification uses the three LT interfaces to communicate with the MS, the system under test, and with the other parts of the test system:

- Interface to the L2 emulator via the PCO;

- Interface to the management functional unit via TTCN test suite operations;
- Interface to the MS Man-Machine Interface (MMI) via a test operator.

6.2 Test Method

The PCO in the LT is defined as L2 SAP (SAP 0 + 3). The PCO has two FIFO queues (data buffers) to store all sending and receiving test events. The L2 primitives in the ATS which constitute mainly the interface to the L2 emulator are specified via the L2 primitives. In order to simulate multicell testing as required in some test cases, the defined primitives are able to address individual cells of the test system and the logic channels of each cell for the L3 message exchanges. The L2 emulator together with the underlying L1 and the TRx set support all message exchanges via correct radio links.

The management function unit has three management functions:

- L2 and L1 management;
- Channel management;
- TRx management;

The interface to the management function unit is presented in the ATS via a set of test suite operations. The major functions of the test suite management operations are:

- To load configuration parameters necessary for the test system.
- To control and get the necessary values of radio resources/ channels for tests.

The SUT (MS) has a more or less standardized MMI, such as keys, digital display, tones, etc. The ATS uses such kind of functions to provoke some procedures or to observe simple results at the SUT side. A human operator is needed during the test. The test system shall have an interface to the human operator to enable the test co-ordination.

Annex A (normative): Partial IXIT proforma

Notwithstanding the provisions of the copyright clause related to the text of the present document, ETSI grants that users of the present document may freely reproduce the PIXIT proforma in this annex so that it can be used for its intended purposes and may further publish the completed PIXIT.
--

A.0 Introduction

This partial IXIT proforma contained in the present document, after augmented by the Test Realizer, is proposed to be provided to the client for completion, when the related Abstract Test Suite is to be used against client's Implementation Under Test (IUT).

Text in *italics* is comments for guidance for the production of a IXIT, and is not to be included in the actual IXIT.

The completed IXIT will normally be used in conjunction with the completed ICS, as it adds precision to the information provided by the ICS.

A.1 Identification Summary

This table is completed by the test laboratory. The item "Contract References" is optional.

Table 1: Identification Summary

IXIT Reference Number	
Test Laboratory Name	
Date of Issue	
Issued to (name of client)	
Contract References	

A.2 Abstract Test Suite Summary

In the following table the test laboratory provides the version number of the protocol specification and the version number of ATS which are used in the conformance testing.

Table 2: ATS Summary

Protocol Specification	EN 300 557
Version of Protocol Specification	
TSS & TP Specification	EN 300 607-1
Version of TSS & TP Specification	
ATS Specification	EN 300 607-3
Version of ATS Specification	
Abstract Test Method	Distributed Test Method

A.3 Test Laboratory

A.3.1 Test Laboratory Identification

The test laboratory provides the following information.

Table 3: Test Laboratory Identification

Name of Test Laboratory	
Postal Address	
Office address	
e-mail address	
Telephone Number	
FAX Number	

A.3.2 Accreditation status of the test service

The test laboratory provides the following information.

Table 4: Accreditation status of the test service

Accreditation status	
Accreditation Reference	

A.3.3 Manager of Test Laboratory

The test laboratory provides the information about the manager of test laboratory in the following table.

Table 5: Manager of Test Laboratory

Name of Manager of Test Laboratory	
e-mail address	
Telephone Number	
FAX Number	
E-mail Address	

A.3.4 Contact person of Test Laboratory

The test laboratory provides the information about the contact person of test laboratory in the following table.

Table 6: Contact person of Test Laboratory

Name of Contact of Test Laboratory	
e-mail address	
Telephone Number	
FAX Number	
E-mail Address	

A.3.5 Means of Testing

In the table below, the test laboratory provides a statement of conformance of the Means Of Testing (MOT) to the reference standardized ATS, and identifies all restrictions for the test execution required by the MOT beyond those stated in the reference standardized ATS.

Table 7: Means of Testing

Means of Testing

A.3.6 Instructions for Completion

In this table, the test laboratory provides any specific instructions necessary for completion and return of the proforma from the client.

Table 8: Instruction for Completion

Instructions for Completion

A.4 Client

A.4.1 Client Identification

The client provides the identification in the following table.

Table 9: Client Identification

Name of Client	
Postal Address	
Office Address	
Telephone Number	
FAX Number	

A.4.2 Client Test Manager

In this table the client provides information about the test manager.

Table 10: Client Test Manager

Name of Client Test Manager	
Telephone Number	
FAX Number	
E-mail Address	

A.4.3 Client Contact person

In this table the client provides information about the test contact person.

Table 11: Client Contact person

Name of Client contact person	
Telephone Number	
FAX Number	
E-mail Address	

A.4.4 Test Facilities Required

In the following table, the client records the particular facilities required for testing, if a range of facilities is provided by the test laboratory.

Table 12: Test Facilities Required

Test Facilities Required

A.5 System Under Test

A.5.1 SUT Information

The client provides information about the SUT in the table below.

Table 13: SUT Information

System Name	
System Version	
SCS Reference	
Machine Configuration	
Operating System Identification	
IUT Identification	
ICS Reference for the IUT	

A.5.2 Limitations of the SUT

In the table below, the client provides information explaining if any of the abstract tests cannot be executed.

Table 14: Limitation of the SUT

Limitations of the SUT

A.5.3 Environmental Conditions

In the table below the client provides information about any tighter environmental conditions for the correct operation of the SUT.

Table 15: Environmental Conditions

Environmental Conditions

A.6 Ancillary Protocols

This clause is completed by the client in conjunction with the test laboratory.

In the following tables, the client identifies relevant information concerning each ancillary protocol in the SUT other than the IUT itself. One table for one ancillary protocol.

Based on the MOT the test laboratory should create question proforma for each ancillary protocol in the blank space following each table. The information required is dependent on the MOT and the SUT, and covers all the addressing, parameter values, timer values and facilities (relevant to ENs) as defined by the ICS for the ancillary protocol.

A.6.1 Ancillary Protocols 1

Table 16: Ancillary Protocol 1

Protocol Name	EN 300
Version number	
ICS Reference (optional)	
IXIT Reference (optional)	
PCTR Reference (optional)	

A.6.2 Ancillary Protocols 2

Table 17: Ancillary Protocol 2

Protocol Name	EN 300
Version number	
ICS Reference (optional)	
IXIT Reference (optional)	
PCTR Reference (optional)	

A.7 Protocol Layer Information for L3 of Mobile Station

A.7.1 Information provided for test purposes by the MS supplier

Item	Description	Type/Allowed values	Supported Value	Release
TSPC_24DataF	2.4 k full rate data mode supported – must be TRUE if TSPC_24DataH = TRUE	BOOLEAN		Phase 2
TSPC_24DataH	2.4 k half rate data mode supported	BOOLEAN		Phase 2
TSPC_48DataF	4.8 k full rate data mode supported– must be TRUE if TSPC_48DataH = TRUE	BOOLEAN		Phase 2
TSPC_48DataH	4.8 k half rate data mode supported	BOOLEAN		Phase 2
TSPC_96Data	9.6 k full rate data mode supported	BOOLEAN		Phase 2
TSPC_Feat_A51	ciphering algorithm A5/1 supported	BOOLEAN		Phase 2

Item	Description	Type/Allowed values	Supported Value	Release
TSPC_Feat_A52	ciphering algorithm A5/2 supported	BOOLEAN		Phase 2
TSPC_AddCharSet	A, B, C, D chars supported	BOOLEAN		Phase 2
TSPC_AddInfo_PseudoSynch	Pseudo synchronized supported	BOOLEAN		Phase 2
TSPC_AlertInd	alerting indication to the user supported	BOOLEAN		Phase 2
TSPC_SvcOnTCH	at least one service on traffic channel supported	BOOLEAN		Phase 2
TSPC_SMS	at least one short message service supported	BOOLEAN		Phase 2
TSPC_SS	at least one supplementary service supported	BOOLEAN		Phase 2
TSPC_AutoAutoMode	automatically enter automatic selection of PLMN mode supported	BOOLEAN		Phase 2
TSPC_BasCharSet	Chars 0-9, *, # supported	BOOLEAN		Phase 2
TSPC_CalledNumDisp	called number display supported	BOOLEAN		Phase 2
TSPC_DCS	testing DCS1 800	BOOLEAN		Phase 2
TSPC_DetachOnPwrDn	detach on power down supported	BOOLEAN		Phase 2
TSPC_DetachOnSIMRmv	detach on SIM remove supported	BOOLEAN		Phase 2
TSPC_DisprcvSMS	display of received SMS supported	BOOLEAN		Phase 2
TSPC_DualRate	dual rate channel types supported	BOOLEAN		Phase 2
TSPC_EGSM	both standard (PGSM) and extended GSM band supported	BOOLEAN		Phase 2
TSPC_EmgOnly	the only circuit switched basic service is emergency call	BOOLEAN		Phase 2
TSPC_followOnReq	follow-on request procedure supported	BOOLEAN		Phase 2
TSPC_HalfRateData	at least one half rate data supported	BOOLEAN		Phase 2
TSPC_HalfRateSpeech	half rate speech mode supported	BOOLEAN		Phase 2
TSPC_InCallMod	In-Call modification supported	BOOLEAN		Phase 2
TSPC_NoimmConn	at least one service not support immediate connection	BOOLEAN		Phase 2
TSPC_Feat_FND	FND feature supported	BOOLEAN		Phase 2
TSPC_NonCallSS	non call related supplementary service supported	BOOLEAN		Phase 2
TSPC_MTsvc	at least one MT circuit switched basic service supported	BOOLEAN		Phase 2
TSPC_MOsvc	at least one MO circuit switched basic service supported	BOOLEAN		Phase 2
TSPC_PGSM	only standard GSM band supported	BOOLEAN		Phase 2

Item	Description	Type/Allowed values	Supported Value	Release
TSPC_RefusalCall	refusal of call supported	BOOLEAN		Phase 2
TSPC_ReplaceSMS	replace SMS supported	BOOLEAN		Phase 2
TSPC_ReplyProc	(SMS) reply procedures supported	BOOLEAN		Phase 2
TSPC_RFAmp	RF amplification supported	BOOLEAN		Phase 2
TSPC_SDCCHOnly	only SDCCH supported	BOOLEAN		Phase 2
TSPC_Serv_SS_AoCC	Advice of Charge (Charging) SS supported	BOOLEAN		Phase 2
TSPC_Serv_SS_BAIC	Barring of All Incoming Calls SS supported	BOOLEAN		Phase 2
TSPC_Serv_SS_BI	BI SS supported	BOOLEAN		Phase 2
TSPC_Serv_SS_BICRoam	Barring of Incoming Calls when Roaming Outside the Home PLMN Country SS supported	BOOLEAN		Phase 2
TSPC_Serv_SS_BAOC	Barring of all Outgoing Calls SS supported	BOOLEAN		Phase 2
TSPC_Serv_SS_BOIC	Barring of Outgoing International Calls SS supported	BOOLEAN		Phase 2
TSPC_Serv_SS_BOICexHC	Barring of Outgoing International Calls except those directed to the Home PLMN Country SS supported	BOOLEAN		Phase 2
TSPC_Serv_SS_CFB	Call Forwarding on Mobile Subscriber Busy SS supported	BOOLEAN		Phase 2
TSPC_Serv_SS_CFNRY	Call Forwarding on No Reply SS supported	BOOLEAN		Phase 2
TSPC_Serv_SS_CFNRC	Call Forwarding on Mobile Subscriber Not Reachable SS supported	BOOLEAN		Phase 2
TSPC_Serv_SS_CFU	Call Forwarding Unconditional SS supported	BOOLEAN		Phase 2
TSPC_Serv_SS_HOLD	Call Hold SS supported	BOOLEAN		Phase 2
TSPC_Serv_SS_MPTY	multiparty SS supported	BOOLEAN		Phase 2
TSPC_Serv_SS_unstruct	USSD supported	BOOLEAN		Phase 2
TSPC_Serv_TS11	telephony supported	BOOLEAN		Phase 2
TSPC_Serv_TS12	emergency call supported	BOOLEAN		Phase 2
TSPC_Serv_TS21	SMS MT/PP supported	BOOLEAN		Phase 2
TSPC_Serv_TS22	SMS MO/PP supported	BOOLEAN		Phase 2
TSPC_Serv_TS23	SMS cell broadcast supported	BOOLEAN		Phase 2
TSPC_Serv_TS61	alternate speech and G3 fax (TS61) supported	BOOLEAN		Phase 2

Item	Description	Type/Allowed values	Supported Value	Release
TSPC_Serv_TS62	automatic G3 fax (TS62) supported	BOOLEAN		Phase 2
TSPC_Serv_BS21	data circuit duplex async 300 bit/s supported	BOOLEAN		Phase 2
TSPC_Serv_BS22	data circuit duplex async 1 200 bit/s supported	BOOLEAN		Phase 2
TSPC_Serv_BS23	data circuit duplex async 1 200/75 bit/s supported	BOOLEAN		Phase 2
TSPC_Serv_BS24	data circuit duplex async 2 400 bit/s supported	BOOLEAN		Phase 2
TSPC_Serv_BS25	data circuit duplex async 4 800 bit/s supported	BOOLEAN		Phase 2
TSPC_Serv_BS26	data circuit duplex async 9 600 bit/s supported	BOOLEAN		Phase 2
TSPC_Serv_BS31	data circuit duplex sync 1 200 bit/s supported	BOOLEAN		Phase 2
TSPC_Serv_BS32	data circuit duplex sync 2 400 bit/s supported	BOOLEAN		Phase 2
TSPC_Serv_BS33	data circuit duplex sync 4 800 bit/s supported	BOOLEAN		Phase 2
TSPC_Serv_BS34	data circuit duplex sync 9 600 bit/s supported	BOOLEAN		Phase 2
TSPC_Serv_BS41	PAD access 300 bit/s supported	BOOLEAN		Phase 2
TSPC_Serv_BS42	PAD access 1 200 bit/s supported	BOOLEAN		Phase 2
TSPC_Serv_BS43	PAD access 1 200/75 bit/s supported	BOOLEAN		Phase 2
TSPC_Serv_BS44	PAD access 2 400 bit/s supported	BOOLEAN		Phase 2
TSPC_Serv_BS45	PAD access 4 800 bit/s supported	BOOLEAN		Phase 2
TSPC_Serv_BS46	PAD access 9 600 bit/s supported	BOOLEAN		Phase 2
TSPC_Serv_BS51	packet access 2 400 bit/s supported	BOOLEAN		Phase 2
TSPC_Serv_BS52	packet access 4 800 bit/s supported	BOOLEAN		Phase 2
TSPC_Serv_BS53	packet access 9 600 bit/s supported	BOOLEAN		Phase 2
TSPC_Serv_BS61	alternate speech/data (BS61) supported	BOOLEAN		Phase 2
TSPC_Serv_BS81	speech followed data (BS81) supported	BOOLEAN		Phase 2
TSPC_SMSStatusRepCap	SMS status report capabilities supported	BOOLEAN		Phase 2
TSPC_StoreRcvSMSME	Storage of received SMS in ME supported	BOOLEAN		Phase 2
TSPC_StoreRcvSMSSIM	Storage of received SMS in SIM supported	BOOLEAN		Phase 2
TSPC_SIMRmv	SIM removable without power down supported	BOOLEAN		Phase 2
TSPC_SwitchOnOff	switch on/off supported	BOOLEAN		Phase 2

Item	Description	Type/Allowed values	Supported Value	Release
TSPC_TranspDataOnly	only transparent data service supported	BOOLEAN		Phase 2
TSPC_CC	CC protocol for at least one BC supported	BOOLEAN		Phase 2
TSPC_TeleSvc	at least one teleservice supported	BOOLEAN		Phase 2
TSPC_EFR	Set to TRUE for EFR MS which supports any EFR features and FALSE otherwise	BOOLEAN		Phase 2
TSPC_EFR_Speech_v2	Set to TRUE for EFR MS which supports EFR Speech Version 2 and FALSE otherwise	BOOLEAN		Phase 2
TSPC_EFR_Speech_v3	Set to TRUE for EFR MS which supports EFR Speech Version 3 and FALSE otherwise	BOOLEAN		Phase 2
TSPC_EFR_EmgCallBcap	Set to TRUE if received ESETUP message contains bearer capability IE, otherwise FALSE	BOOLEAN		Phase 2
TSPC_FullRateSpeech	full rate speech mode supported – must be TRUE if TSPC_HalfRateSpeech = TRUE	BOOLEAN		Phase 2
TSPC_FullRateOnly	only full rate channel type supported	BOOLEAN		Phase 2
TSPC_StoredListCellSel	Stored List Cell Selection supported	BOOLEAN		Phase 2
TSPC_RGSM	both standard and R- GSM band supported	BOOLEAN		R96
TSPC_VGCS_Listening	VGCS listening supported	BOOLEAN		R96
TSPC_VGCS_Talking	VGCS talking supported	BOOLEAN		R96
TSPC_VGCS_Originating	VGCS call originating supported	BOOLEAN		R96
TSPC_VBS_Listening	VBS listening supported	BOOLEAN		R96
TSPC_VBS_Originating	VBS call originating supported	BOOLEAN		R96
TSPC_Reduced_Monitoring	Reduced monitoring on NCH supported	BOOLEAN		R96
TSPC_MonitorPCH_GroupTransmitMode	Monitor PCH in group transmit mode supported	BOOLEAN		R96
TSPC_Serv_SS_eMLPP	eMLPP service supported	BOOLEAN		R96
TSPC_Serv_SS_CallWaiting	Call waiting SS supported	BOOLEAN		R96

Item	Description	Type/Allowed values	Supported Value	Release
TSPC_Serv_SS_UUS	User-to-User Signalling	BOOLEAN		R00
TSPC_Serv_SS_ImpUUS1	Implicit UUS1	BOOLEAN		R00
TSPC_Serv_SS_Send_UUS1_ALERTING	Sending of implicit UUS1 in the ALERTING message	BOOLEAN		R00
TSPC_Serv_SS_Send_UUS1_CONNECT	Sending of implicit UUS1 in the ALERTING message	BOOLEAN		R00
TSPC_Serv_SS_FollowMe	Follow Me	BOOLEAN		R00
TSPC_Serv_UTDI	User-to-Dispatcher Information	BOOLEAN		R00
TSPC_Serv_Compr_UTDI	Compressed User-to-Dispatcher	BOOLEAN		R00
TSPX_TE_stopbit	Terminal Equipment configuration number stop bits. default value : '0'B, 1 bit	BITSTRING[1]		Phase 2
TSPX_TE_databit	Terminal Equipment configuration number data bits. '0'B, 7bits, '1'B, 8bits - default value : '1'B, 8 bits	BITSTRING[1]		Phase 2
TSPX_TE_FLCT	Terminal Equipment flow control. Type of flow control. 0-outband flow control, 1-inband flow control, 2-no flow control. default : 0, outband flow control	0, 1, 2		Phase 2
TSPX_TE_parity	Terminal Equipment configuration parity. 000=odd, 010=even, 011=none, 100=forced to 0, 101=forced to 1. default : '001'B, no parity	BITSTRING[3]		Phase 2
TSPX_BS_21_its1	Information Transfer Capability value supported for BS21(async data 300bit/s). default value : '001'B, Unrestricted Digital Information	BITSTRING[3]		Phase 2
TSPX_BS_21_more_its	more than one Information Transfer Capability value supported by BS21(async data 300bit/s). default value : FALSE, only one its	BOOLEAN		Phase 2
TSPX_BS_21_T_NT	both Transparent and Non-Transparent supported by BS21(async data 300bit/s). default value : FALSE, not support both transparent and non transparent modes	BOOLEAN		Phase 2
TSPX_BS_21_ce	BS21(async data 300bit/s). Connection Element value used in MO call and if the answer to TSPX_BS_21_T_NT is FALSE, the manufacturer must precise which mode is supported by the MS. default value : '00'B, transparent mode	BITSTRING[2]		Phase 2

Item	Description	Type/Allowed values	Supported Value	Release
TSPX_BS_21_sacp	BS21(async data 300bit/s). Signalling Access Protocol value used in MO call. default value : '001'B, I440/450	BITSTRING[3]		Phase 2
TSPX_BS_21_itc2	other Information Transfer Capability value supported by BS21(async data 300bit/s), it shall be different from the previous one if the answer to TSPX_BS_21_more_itc is TRUE. default value : '001'B, Unrestricted Digital Information	BITSTRING[3]		Phase 2
TSPX_BS_22_itc1	Information Transfer Capability value supported by BS22(async data 1200bit/s). default value : '010'B, 3.1kHz audio, exPLMN	BITSTRING[3]		Phase 2
TSPX_BS_22_more_itc	more than one Information Transfer Capability value supported by BS22(async data 1200bit/s). default value : FALSE, only one itc	BOOLEAN		Phase 2
TSPX_BS_22_T_NT	both Transparent and Non-Transparent supported by BS22(async data 1200bit/s). default value : FALSE, not support both transparent and non transparent modes	BOOLEAN		Phase 2
TSPX_BS_22_ce	BS22(async data 1200bit/s) Connection Element value used in MO call and if the answer to TSPX_BS_22_T_NT is FALSE, the manufacturer must precise which mode is supported by the MS. default value : '01'B, non transparent	BITSTRING[2]		Phase 2
TSPX_BS_22_sacp	BS22(async data 1200bit/s) Signalling Access Protocol value used in MO call. default value : '001'B, I440/450	BITSTRING[3]		Phase 2
TSPX_BS_22_itc2	other Information Transfer Capability value supported by BS22(async data 1200bit/s), it shall be different from the previous one if the answer to TSPX_BS_22_more_itc is TRUE. default value : '010'B, 3.1kHz audio, exPLMN	BITSTRING[3]		Phase 2
TSPX_BS_23_itc	Information Transfer Capability value supported by BS23(async 1200/75 bit/s). default value : '010'B, 3.1kHz audio, exPLMN	BITSTRING[3]		Phase 2

Item	Description	Type/Allowed values	Supported Value	Release
TSPX_BS_23_T_NT	both Transparent and Non-Transparent supported for BS23(async 1200/75 bit/s). default value : FALSE, not support both transparent and non transparent modes	BOOLEAN		Phase 2
TSPX_BS_23_ce	BS23(async 1200/75 bit/s) Connection Element value used in MO call. default value : '00'B, transparent	BITSTRING[2]		Phase 2
TSPX_BS_23_sacp	BS23(async 1200/75 bit/s) Signalling Access Protocol value used in MO call. default value : '001'B, I440/450	BITSTRING[3]		Phase 2
TSPX_BS_24_itc1	Information Transfer Capability value supported by BS24(async 2400 bit/s). default value : '010'B, 3.1kHz audio, exPLMN	BITSTRING[3]		Phase 2
TSPX_BS_24_more_itc	more than one Information Transfer Capability value supported by BS24(async 2400 bit/s). default value : FALSE, only one itc	BOOLEAN		Phase 2
TSPX_BS_24_T_NT	both Transparent and Non-Transparent supported by BS24(async 2400 bit/s). default value : FALSE, not support both transparent and non transparent modes	BOOLEAN		Phase 2
TSPX_BS_24_ce	BS24(async 2400 bit/s) Connection Element value used in MO call and if the answer to TSPX_BS_24_T_NT is FALSE, the manufacturer must precise which mode is supported by the MS. default value : '00'B, transparent	BITSTRING[2]		Phase 2
TSPX_BS_24_sacp	BS24(async 2400 bit/s) Signalling Access Protocol value used in MO call. default value : '001'B, I440/450	BITSTRING[3]		Phase 2
TSPX_BS_24_itc2	other Information Transfer Capability value supported by BS24(async 2400 bit/s), it shall be different from the previous one if the answer to TSPX_BS_24_more_itc is TRUE. default value : '010'B, 3.1kHz audio, exPLMN	BITSTRING[3]		Phase 2
TSPX_BS_25_itc1	Information Transfer Capability value supported by BS25(async 4800 bit/s). default value : '001'B, Unrestricted Digital Information	BITSTRING[3]		Phase 2

Item	Description	Type/Allowed values	Supported Value	Release
TSPX_BS_25_more_its	more than one Information Transfer Capability value supported by BS25(async 4800 bit/s). default value : FALSE, only one its	BOOLEAN		Phase 2
TSPX_BS_25_T_NT	both Transparent and Non-Transparent supported by BS25(async 4800 bit/s). default value : FALSE, not support both transparent and non transparent modes	BOOLEAN		Phase 2
TSPX_BS_25_ce	BS25(async 4800 bit/s) Connection Element value used in MO call and if the answer to TSPX_BS_25_T_NT is FALSE, the manufacturer must precise which mode is supported by the MS. default value : '00'B, transparent	BITSTRING[2]		Phase 2
TSPX_BS_25_sacp	BS25(async 4800 bit/s) Signalling Access Protocol value used in MO call. default value : '001'B, I440/450	BITSTRING[3]		Phase 2
TSPX_BS_25_its2	other Information Transfer Capability value supported by BS25(async 4800 bit/s), it shall be different from the previous one if the answer to TSPX_BS_25_more_its is TRUE. default value : '001'B, Unrestricted Digital Information	BITSTRING[3]		Phase 2
TSPX_BS_26_its1	Information Transfer Capability value supported by BS26(async 9600 bit/s). default value : '010'B, 3.1kHz audio, exPLMN	BITSTRING[3]		Phase 2
TSPX_BS_26_more_its	more than one Information Transfer Capability value supported by BS26(async 9600 bit/s). default value : FALSE, only one its	BOOLEAN		Phase 2
TSPX_BS_26_T_NT	both Transparent and Non-Transparent supported by BS26(async 9600 bit/s). default value : FALSE, not support both transparent and non transparent modes	BOOLEAN		Phase 2
TSPX_BS_26_ce	BS26(async 9600 bit/s) Connection Element value used in MO call and if the answer to TSPX_BS_26_T_NT is FALSE, the manufacturer must precise which mode is supported by the MS. default value : '00'B, transparent	BITSTRING[2]		Phase 2

Item	Description	Type/Allowed values	Supported Value	Release
TSPX_BS_26_sacp	BS26(async 9600 bit/s) Signalling Access Protocol value used in MO call. default value : '001'B, I440/450	BITSTRING[3]		Phase 2
TSPX_BS_26_itc2	other Information Transfer Capability value supported by BS26, it shall be different from the previous one if the answer to TSPX_BS_26_more_itc is TRUE. default value : '010'B, 3.1kHz audio, exPLMN	BITSTRING[3]		Phase 2
TSPX_BS_31_more_itc	more than one Information Transfer Capability value supported by BS31(sync data 1200 bit/s). default value : FALSE, only one itc	BOOLEAN		Phase 2
TSPX_BS_31_more_sacp	more than one Signalling Access Protocol value supported by BS31(sync data 1200 bit/s). default value : FALSE, only one sacp	BOOLEAN		Phase 2
TSPX_BS_31_itc1	Information Transfer Capability value supported by BS31(sync data 1200 bit/s). default value : '001'B, Unrestricted Digital Information	BITSTRING[3]		Phase 2
TSPX_BS_31_sacp1	Signalling Access Protocol value supported by BS31(sync data 1200 bit/s). default value : '001'B, I440/450	BITSTRING[3]		Phase 2
TSPX_BS_31_itc2	other Information Transfer Capability value supported by BS31(sync data 1200 bit/s), it shall be different from the previous one if the answer to TSPX_BS_31_more_itc is TRUE. default value : '001'B, Unrestricted Digital Information	BITSTRING[3]		Phase 2
TSPX_BS_31_sacp2	other Signalling Access Protocol value supported by BS31(sync data 1200 bit/s), it shall be different from the previous one if the answer to TSPX_BS_31_more_Signalling Access Protocol is TRUE. default value : '001'B, I440/450	BITSTRING[3]		Phase 2
TSPX_BS_32_itc1	Information Transfer Capability value supported by BS32(sync data 2400 bit/s). default value : '010'B, 3.1kHz audio, exPLMN	BITSTRING[3]		Phase 2
TSPX_BS_32_more_itc	more than one Information Transfer Capability value supported by BS32(sync data 2400 bit/s). default value : FALSE, only one itc	BOOLEAN		Phase 2

Item	Description	Type/Allowed values	Supported Value	Release
TSPX_BS_32_more_sacp	more than one Signalling Access Protocol value supported by BS32(sync data 2400 bit/s). default value : FALSE, only one sacp	BOOLEAN		Phase 2
TSPX_BS_32_sacp1	Signalling Access Protocol value supported by BS32(sync data 2400 bit/s). default value : '110'B, X.32	BITSTRING[3]		Phase 2
TSPX_BS_32_X32_T_NT	BS 32(sync data 2400 bit/s) both Transparent and Non-Transparent supported for X32 3.1kHz. default value : FALSE, not support both transparent and non transparent modes	BOOLEAN		Phase 2
TSPX_BS_32_X32_ce	BS32(sync data 2400 bit/s). If the answer to TSPX_BS_32_X32_T_NT is FALSE, the manufacturer must precise which mode is supported by the MS. Connection Element default value : '01'B, non transparent	BITSTRING[2]		Phase 2
TSPX_BS_32_itc2	other Information Transfer Capability value supported by BS32(sync data 2400 bit/s), it shall be different from the previous one if the answer to TSPX_BS_32_more_itc is TRUE. default value : '010'B, 3.1kHz audio, exPLMN	BITSTRING[3]		Phase 2
TSPX_BS_32_sacp2	other Signalling Access Protocol value supported by BS32(sync data 2400 bit/s), it shall be different from the previous one if the answer to TSPX_BS_32_more_sacp is TRUE. default value : '110'B, X.32	BITSTRING[3]		Phase 2
TSPX_BS_33_itc1	Information Transfer Capability value supported by BS33 (sync data 4800 bit/s). default value : '001'B, Unrestricted Digital Information	BITSTRING[3]		Phase 2
TSPX_BS_33_more_itc	more than one Information Transfer Capability value supported by BS33(sync data 4800 bit/s). default value : FALSE, only one itc	BOOLEAN		Phase 2
TSPX_BS_33_more_sacp	more than one Signalling Access Protocol value supported by BS33(sync data 4800 bit/s). default value : FALSE, only one sacp	BOOLEAN		Phase 2

Item	Description	Type/Allowed values	Supported Value	Release
TSPX_BS_33_sacp1	Signalling Access Protocol value supported by BS33(sync data 4800 bit/s). default value : '010'B, X.21	BITSTRING[3]		Phase 2
TSPX_BS_33_X32_T_NT	BS 33(sync data 4800 bit/s) both Transparent and Non-Transparent supported for X32 3.1kHz. default value : FALSE, not support both transparent and non transparent modes	BOOLEAN		Phase 2
TSPX_BS_33_X32_ce	BS33(sync data 4800 bit/s). If the answer to TSPX_BS_33_X32_T_NT is FALSE, the manufacturer must precise which mode is supported by the MS. Connection Element default value : '00'B, transparent	BITSTRING[2]		Phase 2
TSPX_BS_33_itc2	other Information Transfer Capability value supported by BS33(sync data 4800 bit/s), it shall be different from the previous one if the answer to TSPX_BS_33_more_itc is TRUE. default value : '001'B, Unrestricted Digital Information	BITSTRING[3]		Phase 2
TSPX_BS_33_sacp2	other Signalling Access Protocol value supported by BS33(sync data 4800 bit/s), it shall be different from the previous one if the answer to TSPX_BS_33_more_sacp is TRUE. default value : '010'B, X.21	BITSTRING[3]		Phase 2
TSPX_BS_34_itc1	Information Transfer Capability value supported by BS34(sync data 9600 bit/s). default value : '010'B, 3.1kHz audio, exPLMN	BITSTRING[3]		Phase 2
TSPX_BS_34_more_itc	more than one Information Transfer Capability value supported by BS34(sync data 9600 bit/s). default value : FALSE, only one itc	BOOLEAN		Phase 2
TSPX_BS_34_more_sacp	more than one Signalling Access Protocol value supported by BS34(sync data 9600 bit/s). default value : FALSE, only one sacp	BOOLEAN		Phase 2
TSPX_BS_34_sacp1	Signalling Access Protocol value supported by BS34(sync data 9600 bit/s). default value : '001'B, I440/450	BITSTRING[3]		Phase 2
TSPX_BS_34_X32_T_NT	BS 34(sync data 9600 bit/s) both Transparent and Non-Transparent supported for X32 3.1kHz. default value : FALSE, not support both transparent and non transparent modes	BOOLEAN		Phase 2

Item	Description	Type/Allowed values	Supported Value	Release
TSPX_BS_34_X32_ce	BS34(sync data 9600 bit/s). If the answer to TSPX_BS_34_X32_T_NT is FALSE, the manufacturer must precise which mode is supported by the MS. Connection Element default value : '00'B, transparent	BITSTRING[2]		Phase 2
TSPX_BS_34_itc2	other Information Transfer Capability value supported by BS34(sync data 9600 bit/s), it shall be different from the previous one if the answer to TSPX_BS_34_more_itc is TRUE. default value : '010'B, 3.1kHz audio, exPLMN	BITSTRING[3]		Phase 2
TSPX_BS_34_sacp2	other Signalling Access Protocol value supported by BS34(sync data 9600 bit/s), it shall be different from the previous one if the answer to TSPX_BS_34_more_sacp is TRUE. default value : '001'B, I440/450	BITSTRING[3]		Phase 2
TSPX_BS_41_T_NT	BS41(PAD access 300 bit/s) both Transparent and Non-Transparent supported . default value : FALSE, not support both	BOOLEAN		Phase 2
TSPX_BS_41_ce	Connection Element value used in BS41(PAD access 300 bit/s) MO call. default value : '00'B, transparent	BITSTRING[2]		Phase 2
TSPX_BS_42_T_NT	BS42(PAD access 1200 bit/s) both Transparent and Non-Transparent supported . default value : FALSE, not support both transparent and non transparent modes	BOOLEAN		Phase 2
TSPX_BS_42_ce	Connection Element value used in BS42(PAD access 1200 bit/s) MO call. default value : '00'B, transparent	BITSTRING[2]		Phase 2
TSPX_BS_43_T_NT	BS43(PAD access 1200/75 bit/s) both Transparent and Non-Transparent supported . default value : FALSE, not support both transparent and non transparent modes	BOOLEAN		Phase 2
TSPX_BS_43_ce	Connection Element value used in BS43(PAD access 1200/75 bit/s) MO call. default value : '00'B, transparent	BITSTRING[2]		Phase 2

Item	Description	Type/Allowed values	Supported Value	Release
TSPX_BS_44_T_NT	BS44(PAD access 2400 bit/s) both Transparent and Non-Transparent supported . default value : FALSE, not support both transparent and non transparent modes	BOOLEAN		Phase 2
TSPX_BS_44_ce	Connection Element value used in BS44(PAD access 2400 bit/s) MO call. default value : '00'B, transparent	BITSTRING[2]		Phase 2
TSPX_BS_45_T_NT	BS45(PAD access 4800 bit/s) both Transparent and Non-Transparent supported . default value : FALSE, not support both transparent and non transparent modes	BOOLEAN		Phase 2
TSPX_BS_45_ce	Connection Element value used in BS45(PAD access 4800 bit/s) MO call. default value : '00'B, transparent	BITSTRING[2]		Phase 2
TSPX_BS_46_T_NT	BS46(PAD access 9600 bit/s) both Transparent and Non-Transparent supported . default value : FALSE, not support both transparent and non transparent modes	BOOLEAN		Phase 2
TSPX_BS_46_ce	Connection Element value used in BS46(PAD access 9600 bit/s) MO call. default value : '00'B, transparent	BITSTRING[2]		Phase 2
TSPX_BS_61_S	synchronous data supported by BS 61(alternate speech/data) . default value : TRUE, synchronous mode	BOOLEAN		Phase 2
TSPX_BS_61_S_more_ur	more than one user rate for synchronous data service supported by BS61(alternate speech/data). default value : FALSE, only ine user rate	BOOLEAN		Phase 2
TSPX_BS_61_S_ur1	user rate value supported for synchronous data service of BS61(alternate speech/data). default value : '0100'B, 4.8 kbit/s	BITSTRING[4]		Phase 2
TSPX_BS_61_S_ur2	another user rate value supported for synchronous data service of BS61(alternate speech/data). it shall be different from the previous one if the answer to TSPX_BS_61_S_more_ur is TRUE. default value : '0100'B, 4.8 kbit/s	BITSTRING[4]		Phase 2
TSPX_BS_61_A	asynchronous data service supported by BS61(alternate speech/data) . default value : TRUE, asynchronous	BOOLEAN		Phase 2

Item	Description	Type/Allowed values	Supported Value	Release
TSPX_BS_61_A_ur1	user rate value supported for asynchronous data service of BS61(alternate speech/data). default value : '0101'B, 9.6 kbit/s	BITSTRING[4]		Phase 2
TSPX_BS_61_A_ur1_T_NT	both Transparent and Non-Transparent supported for the rate TSPX_BS_61_A_ur1 of BS61(alternate speech/data). default value : FALSE, not support both transparent and non transparent modes	BOOLEAN		Phase 2
TSPX_BS_61_A_ur1_ce	BS61(alternate speech/data). If the answer to TSPX_BS_61_A_ur1_T_NT is FALSE, the manufacturer must precise which mode is supported by the MS. Connection Element default value : '00'B, transparent	BITSTRING[2]		Phase 2
TSPX_BS_61_A_more_ur	more than one user rate for asynchronous data service supported by BS61(alternate speech/data). default value : FALSE, only one user rate	BOOLEAN		Phase 2
TSPX_BS_61_A_ur2	another user rate value supported for asynchronous data service of BS61(alternate speech/data).. it shall be different from the previous one if the answer to TSPX_BS_61_A_more_ur is TRUE. default value : '0101'B, 9.6 kbit/s	BITSTRING[4]		Phase 2
TSPX_BS_61_A_ur2_T_NT	BS61(alternate speech/data). both Transparent and Non-Transparent supported for the rate TSPX_BS_61_A_ur2 of BS61. default value : FALSE, not support both transparent and non transparent modes	BOOLEAN		Phase 2
TSPX_BS_81_S	synchronous data supported by BS 81(speech followed by data). default value : TRUE, synchronous mode	BOOLEAN		Phase 2
TSPX_BS_81_S_more_ur	more than one user rate for synchronous data service supported by BS81(speech followed by data). default value : FALSE, only one user rate	BOOLEAN		Phase 2
TSPX_BS_81_S_ur1	user rate value supported for synchronous data service of BS81(speech followed by data). default value : '0101'B, 9.6 kbit/s	BITSTRING[4]		Phase 2

Item	Description	Type/Allowed values	Supported Value	Release
TSPX_BS_81_S_ur2	another user rate value supported for synchronous data service of BS81(speech followed by data). it shall be different from the previous one if the answer to TSPX_BS_81_S_more_ur is TRUE. default value : '0101'B, 9.6 kbit/s	BITSTRING[4]		Phase 2
TSPX_BS_81_A	asynchronous data service supported by BS81(speech followed by data). default value : TRUE, asynchronous mode	BOOLEAN		Phase 2
TSPX_BS_81_A_ur1	user rate value supported for asynchronous data service of BS81(speech followed by data). default value : '0100'B, 4.8 kbit/s	BITSTRING[4]		Phase 2
TSPX_BS_81_A_ur1_T_NT	both Transparent and Non-Transparent supported for the rate TSPX_BS_81_A_ur1 of BS81(speech followed by data). default value : FALSE, not support both transparent and non transparent modes	BOOLEAN		Phase 2
TSPX_BS_81_A_ur1_ce	BS81(speech followed by data). if the answer to TSPX_BS_81_A_ur1_T_NT is FALSE, the manufacturer must precise which mode is supported by the MS. Connection Element default value : '01'B, non transparent	BITSTRING[2]		Phase 2
TSPX_BS_81_A_more_ur	more than one user rate for asynchronous data service supported by BS81(speech followed by data). default value : FALSE, only one user rate	BOOLEAN		Phase 2
TSPX_BS_81_A_ur2	another user rate value supported for asynchronous data service of BS81(speech followed by data). it shall be different from the previous one if the answer to TSPX_BS_81_A_more_ur is TRUE. default value : '0100'B, 4.8 kbit/s	BITSTRING[4]		Phase 2
TSPX_BS_81_A_ur2_T_NT	both Transparent and Non-Transparent supported for the rate TSPX_BS_81_A_ur2 of BS81(speech followed by data). default value : FALSE, not support both transparent and non transparent modes	BOOLEAN		Phase 2

Item	Description	Type/Allowed values	Supported Value	Release
TSPX_TS_61_T_NT	both Transparent and Non-Transparent supported for TS61(alternate speech and G3 fax). default value : FALSE, not support both transparent and non transparent modes	BOOLEAN		Phase 2
TSPX_TS_61_ce	TS61(alternate speech and G3 fax). if the answer to TSPX_TS_61_T_NT is FALSE, the manufacturer must precise which mode is supported by the MS. Connection Element default value : '01'B, non transparent	BITSTRING[2]		Phase 2
TSPX_TS_61_ur1	user rate for TS61(alternate speech and G3 fax). default value : '0101'B, 9.6 kbit/s	BITSTRING[4]		Phase 2
TSPX_TS_61_more_ur	more than one user rate supported for TS61(alternate speech and G3 fax). default value : FALSE, only one user rate	BOOLEAN		Phase 2
TSPX_TS_61_ur2	another user rate for TS61(alternate speech and G3 fax), it shall be different from the previous one if the answer to TSPX_TS_61_more_ur is TRUE. default value : '0101'B, 9.6 kbit/s	BITSTRING[4]		Phase 2
TSPX_TS_62_T_NT	both Transparent and Non-Transparent supported for TS62(automatic G3 fax). default value : FALSE, not support both transparent and non transparent modes	BOOLEAN		Phase 2
TSPX_TS_62_ce	TS62(automatic G3 fax). if the answer to TSPX_TS_62_T_NT is FALSE, the manufacturer must precise which mode is supported by the MS. Connection Element default value : '00'B, transparent	BITSTRING[2]		Phase 2
TSPX_TS_62_ur1	user rate for TS62(automatic G3 fax). default value : '0100'B, 4.8 kbit/s	BITSTRING[4]		Phase 2
TSPX_TS_62_more_ur	more than one user rate supported by TS62(automatic G3 fax). default value : FALSE, only one user rate	BOOLEAN		Phase 2
TSPX_TS_62_ur2	another user rate for TS62(automatic G3 fax), it shall be different from the previous one if the answer to TSPX_TS_62_more_ur is TRUE. default value : '0100'B, 4.8 kbit/s	BITSTRING[4]		Phase 2
TSPX_DTMF	call control capabilities: value '1'B means MS supports DTMF	BITSTRING[1]		Phase 2
TSPX_modF	any non signalling full rate channel mode for TC_26_6_4_1	BITSTRING[8]		Phase 2

Item	Description	Type/Allowed values	Supported Value	Release
TSPX_modH	any non signalling half channel mode for TC_26_6_4_1	BITSTRING[8]		Phase 2
TSPX_anymod	Any supported channel mode value except signalling and Full rate speech.	BITSTRING[8]		Phase 2
TSPX_CKSNA	cipher key sequence number GSM 04.08, 10.5.1.2	BITSTRING[3]		Phase 2
TSPX_CKSNB	cipher key sequence number GSM 04.08, 10.5.1.2	BITSTRING[3]		Phase 2
TSPX_CKSNC	cipher key sequence number GSM 04.08, 10.5.1.2	BITSTRING[3]		Phase 2
TSPX_CKSNDef	default cipher key sequence number GSM 04.08, 10.5.1.2	BITSTRING[3]		Phase 2
TSPX_RfPwrCap	RF power capability GSM: '000'B Class 1 to '100'B Class 5 DCS: '000'B Class 1 to '010'B Class 3	BITSTRING[3]		Phase 2
TSPX_RevLevel	Revision level of classmark 1 – '00'B Phase 1, '01'B Phase 2	BITSTRING[2]		Phase 2
TSPX_CiphAlgA5_1	Default Algorithm - A5/1 algorithm: NB '0'B : available, '1'B: not available	BITSTRING[1]		Phase 2
TSPX_CiphAlgA5_2	A5/2 algorithm: '1'B : available, '0'B: not available	BITSTRING[1]		Phase 2
TSPX_CiphAlgA5_3	A5/3 algorithm: '1'B : available, '0'B: not available	BITSTRING[1]		Phase 2
TSPX_CiphAlgA5_4	A5/4 algorithm: '1'B : available, '0'B: not available	BITSTRING[1]		Phase 2
TSPX_CiphAlgA5_5	A5/5 algorithm: '1'B : available, '0'B: not available	BITSTRING[1]		Phase 2
TSPX_CiphAlgA5_6	A5/6 algorithm: '1'B : available, '0'B: not available	BITSTRING[1]		Phase 2
TSPX_CiphAlgA5_7	A5/7 algorithm: '1'B : available, '0'B: not available	BITSTRING[1]		Phase 2
TSPX_pSyncCap	pseudo synchronization capability, '0'B: not present '1'B: present	BITSTRING[1]		Phase 2
TSPX_SSscmInd	SS screen indicator – GSM 04.80	BITSTRING[2]		Phase 2
TSPX_SMCap	Support of mobile terminated point to point short messages , '0'B: not present '1'B: present	BITSTRING[1]		Phase 2
TSPX_frqCap	EGSM frequency capability. DCS: reserved, GSM: '0'B not support extension band, '1'B support extension band	BITSTRING[1]		Phase 2
TSPX_ClsMk3	classmark 3 indicator, '0'B no addition capability info, '1'B additional capability info in class mark 3	BITSTRING[1]		Phase 2
TSPX_ESIND	Controlled Early Classmark Sending option implementation – default =0, not implemented	BITSTRING[1]		Phase 2

Item	Description	Type/Allowed values	Supported Value	Release
TSPX_RfPwrCapAmp	RF power capability with external RF amplifier GSM: '000'B Class 1 to '100'B Class 5 DCS: '000'B Class 1 to '010'B Class 3	BITSTRING[3]		Phase 2
TSPX_DTMFInd	DTMF indication to user supported	BOOLEAN		Phase 2
TSPX_IMEI	IMEI of the MS.	HEXSTRING		Phase 2
TSPX_IMEISV	IMEISV of the MS. Used in: TC_26_6_8_5, TC_26_7_3_1	HEXSTRING		Phase 2
TSPX_TC1M	timer value for GSM timer TC1M (for SMS)	INTEGER		Phase 2
TSPX_MaxCPDataRetx	max. number of CP data retransmissions for SMS	INTEGER		Phase 2
TSPX_Immconn	Immediate connect for telephony supported ?	BOOLEAN		Phase 2
TSPX_Uupd	user-user protocol discriminator for TC_26_8_3	BITSTRING[8]		Phase 2
TSPX_UuInfo	user-user information for TC_26_8_3	OCTETSTRING		Phase 2
TSPX_UIC	VGCS uplink identity code	BITSTRING[6]		R96
TSPX_T_Term	Max. wait time for termination of a MO call after sending TERMINATION REQUEST	INTEGER (ms)		R96

A.7.2 MMI information

Description	Release
How is the Accumulated Call Meter (ACM) on the SIM read ? NOTE: Used in Operation OO_ACMIncCHK and OO_ACMReading.	Phase 2
How is the ACM on the SIM reset to zero, and ACMmax set to 2 units ? NOTE: Used in Operation OO_ACMSetting.	Phase 2
How is power amplification added to the mobile and removed ? NOTE: Used in Operation OO_AddPwrAmp and OO_RemvPwrAmp.	Phase 2

<p>What alerting indication is given by the mobile?</p> <p>NOTE: Used in Operation OO_AltIndCHK.</p>	Phase 2
<p>How is the called party number displayed on the mobile?</p> <p>NOTE: Used in Operation OO_CalledNumCHK and OO_CalledPtyNumCHK.</p>	Phase 2
<p>How is a call placed on Hold?</p> <p>NOTE: Used in Operation OO_CallHold.</p>	Phase 2
<p>How is the presence of short messages checked in the mobile and how are they displayed?</p> <p>NOTE: Used in Operation OO_CheckAllSMPresentBut4th and OO_CheckMessageDisplayed and OO_DisplaySMAndSendReplySM and OO_ReadSMAAndRemove and OO_RecallAndDisplaySM.</p>	Phase 2
<p>How is the presence of Cell Broadcast short messages in the mobile checked?</p> <p>NOTE: Used in Operation OO_CheckCBSMReceived.</p>	Phase 2
<p>How is it checked whether the memory capacity of the SIM has been exceeded?</p> <p>NOTE: Used in Operation OO_CheckMCEFOOnSIM and OO_CheckMCEFOOnSIMUnset.</p>	Phase 2
<p>How and where is the SIM inserted and removed?</p> <p>NOTE: Used in Operation OO_ConnectSIMSimulator and OO_SIMIns and OO_SIM2Ins and OO_SIM3Ins and OO_SIMRmv.</p>	Phase 2
<p>Does the MS have an 'END' key? If not, what method is used to replace its function?</p> <p>NOTE: Used in Operation OO_DepressEndKey.</p>	Phase 2

How is a number entered in order to make an outgoing call? NOTE: Used in Operation OO_DialCalledNum.	Phase 2
How is a reply to a received short message sent? NOTE: Used in Operation OO_DisplaySMAndSendReplySM.	Phase 2
How is it checked which DTMF character has been sent? NOTE: Used in Operation OO_DTMFIndCHK.	Phase 2
How is the message store of the MS emptied? NOTE: Used in OO_EmptyMessageStorage.	Phase 2
How is a password on the MS entered? NOTE: Used in Operation OO_EnterPswd.	Phase 2
How is an incoming call answered? NOTE: Used in Operation OO_HookOff.	Phase 2
For each service on the MS which requires the MS to be connected to an interface on other equipment (e.g. a computer), how is that interface set up for the purpose? NOTE: Used in Operation OO_IFsetup.	Phase 2
How is an In-Call modification initiated on the MS? NOTE: Used in Operation OO_InCallMod.	Phase 2

<p>For each mobile originating basic service supported by the MS, how is the MS configured to make an outgoing call on that service?</p> <p>NOTE: Used in Operation OO_InitCall.</p>	Phase 2
<p>How is the MS to configured accept standard MMI sequences for the initiation of supplementary services?</p> <p>NOTE: Used in Operation OO_InitSS</p>	Phase 2
<p>How is the MS checked whether it is in the normal service state (idle, updated).</p> <p>NOTE: Used in Operation OO_InServiceCHK and OO_PressKeyWhenInService.</p>	Phase 2
<p>How is a Multi-Party call initiated on the MS.</p> <p>NOTE: Used in Operation OO_MptyCall</p>	Phase 2
<p>How is the MS configured to store received Class 1 short messages in the mobile equipment (rather than in the SIM)?</p> <p>NOTE: Used in Operation OO_MSSetupStoreClass1SMInMEMemory.</p>	Phase 2
<p>How is the list of available PLMNs checked?</p> <p>NOTE: Used in Operation OO_PLMNsCHK.</p>	Phase 2
<p>How is the PLMN selection mode switched to automatic selection.</p> <p>NOTE: Used in operation OO_PLMNselModeAuto.</p>	Phase 2
<p>How is the PLMN selection mode switched to manual selection.</p> <p>NOTE: Used in operation OO_PLMNselModeMan.</p>	Phase 2

<p>How is the power source for the MS removed and replaced. (Note, this is not the same as switching the Mobile on and off using the on/off switch.)</p> <p>NOTE: Used in operation OO_PowerUp and OO_PowerDown.</p>	Phase 2
<p>How is a short message removed from the message store?</p> <p>NOTE: Used in operation OO_ReadSMAndRemove.</p>	Phase 2
<p>When in manual PLMN selection mode, how is a PLMN selected?</p> <p>NOTE: Used in OperationOO_SelPLMN</p>	Phase 2
<p>How is a short message sent from the MS?</p> <p>NOTE: Used in operation OO_SendMOShortMessage.</p>	Phase 2
<p>How is an SMS COMMAND message sent to delete the last short message sent?</p> <p>NOTE: Used in OO_SendSMSCOMMANDDe.</p>	Phase 2
<p>How is an SMS COMMAND message sent enquiring about the last short message sent?</p> <p>NOTE: Used in OO_SendSMS_COMMANDEnq</p>	Phase 2
<p>How is Call Refusal set on the MS?</p> <p>NOTE: Used in Operation OO_SetRefuseCall.</p>	Phase 2
<p>How is a DTMF digit sent?</p> <p>NOTE: Used in operation OO_ShortKeyDepr.</p>	Phase 2

<p>How is it checked whether a supplementary service result is correct?</p> <p>NOTE: Used in Operation OO_SSresultCHK</p>	Phase 2
<p>How is the MS switched on and off?</p> <p>NOTE: Used in operation OO_SwitchOn and OO_SwitchOff.</p>	Phase 2
<p>How is a call cleared?</p> <p>NOTE: Used in operation OO_TermCall.</p>	Phase 2
<p>How does the ASCI MS indicate to the user that an user action is needed for showing the desire of talking?</p> <p>NOTE: Used in operation OO_CheckAsciUserTalkInd.</p>	R96
<p>How is a desire of talking from the user set at the ASCI MS?</p> <p>NOTE: Used in operation OO_AsciUserDesireTalking.</p>	R96
<p>How does the MS indicate a received notification for a group or broadcast call? How is the call reference indicated?</p> <p>NOTE: Used in operation OO_CheckNotifInd</p>	R96
<p>How is a rejection of a group or broadcast call set at the MS when the new group or broadcast call has been indicated?</p> <p>NOTE: Used in operation OO_RejecAsciCall</p>	R96
<p>How does the MS indicate a rejection to an intended request of the user?</p> <p>NOTE: Used in operation OO_CheckAsciReject</p>	R96

<p>How does the MS indicate a received paging information for an MT call when it is in group receive mode or group transmit mode</p> <p>NOTE: Used in operation OO_CheckPagingInfoIndication</p>	R96
<p>How is a rejection of an MT call set at the MS when it is in group receive mode or group transmit mode and has indicated a paging for the MT call?</p> <p>NOTE: Used in operation OO_RejectMTCall</p>	R96
<p>How does the MS indicate the downlink channel is muted?</p> <p>NOTE: Used in operation OO_DownlinkMuted</p>	R96
<p>How is the MS set to be ready for a VGCS configuration or for a VBS configuration?</p> <p>NOTE: Used in operation OO_Ifsetup_Asci</p>	R96
<p>How is a VGCS or a VBS call at the MS initiated?</p> <p>NOTE: Used in operation OO_Initcall_Asci</p>	R96
<p>How is a VGCS or a VBS fast call at the MS initiated?</p> <p>NOTE: Used in operation OO_InitImmediateCall_Asci</p>	R96
<p>How does the MS join a notified VGCS or a VBS call?</p> <p>NOTE: Used in operation OO_Join_AsciCall</p>	R96
<p>How does the MS end an uplink access in a VGCS call?</p> <p>NOTE: Used in operation OO_VGCS_QuitUplinkAccess</p>	R96

<p>How does the MS request an uplink access in a VGCS call?</p> <p>NOTE: Used in operation OO_VGCS_RequestUplinkAccess</p>	R96
<p>How is a priority level set at the MS for an attempt VGCS or VBS call?</p> <p>NOTE: Used in operation OO_SelectPriorityLevel</p>	R96
<p>How is a VGCS or VBS listening stopped?</p> <p>NOTE: Used in operation OO_StopAsciListening</p>	R96
<p>How does the MS indicate that a call has been automatically answered?</p> <p>NOTE: Used in operation OO_CheckCallAutoAnswered</p>	R96
<p>How is implicit USS1 activated ?</p> <p>NOTE: Used in operation OO_ActivateImplicitUUS1</p>	R00
<p>How does the MS display a UUS string ?</p> <p>NOTE: Used in operation OO_CheckUUSDisplay</p>	R00
<p>How does the MS display the Follow Me responses received from the network ?</p> <p>NOTE: Used in operation OO_CheckUssdDisplay</p>	R00
<p>How is the User-to-Dispatcher activated?</p> <p>NOTE: Used in operation OO_ActivateUTDI</p>	R00

A.7.3 Test house specified parameters

Item	Description	Type/Allowed values	Value chosen	Release
TSPX_AltNb	use alternative neighbour cells description. default : FALSE	BOOLEAN		Phase 2
TSPX_CphAlgA	ciphering algorithm identifier – '000' A5/1 to '110' A5/7	OCTETSTRING [1]		Phase 2
TSPX_CphAlgB	ciphering algorithm identifier – '000' A5/1 to '110' A5/7	OCTETSTRING [1]		Phase 2
TSPX_CphAlgC	ciphering algorithm identifier – '000' A5/1 to '110' A5/7	OCTETSTRING [1]		Phase 2
TSPX_CphAlgD	ciphering algorithm identifier – '000' A5/1 to '110' A5/7	OCTETSTRING [1]		Phase 2
TSPX_CphAlgE	ciphering algorithm identifier – '000' A5/1 to '110' A5/7	OCTETSTRING [1]		Phase 2
TSPX_CphAlgDef	default ciphering algorithm identifier – '000' A5/1 to '110' A5/7	OCTETSTRING [1]		Phase 2
TSPX_NoOfHoAccA	number of handover access bursts, value range 10 - 20 TC_26_6_5_1(M=1, 8) TC_26_6_5_2(M=1,8) TC_26_6_5_4_1 TC_26_10_2_4_1 TC_26_10_2_4_2 TC_26_12_2_1(M=1,4,7,11) TC_26_12_2_2(M=1,4,7,8,11) TC_26_11_2_2_1 TC_26_11_5_1 TC_26_11_5_2	INTEGER		Phase 2
TSPX_NoOfHoAccB	number of handover access bursts, value range 10 - 20 TC_26_6_5_1(M=2) TC_26_6_5_2(M=6,9) TC_26_12_2_1(M=2,5,8,13) TC_26_12_2_2(M=2,5,9) TC_26_11_2_2_1	INTEGER		Phase 2
TSPX_NoOfHoAccC	number of handover access bursts, value range 10 - 20 TC_26_6_5_1(M=3) TC_26_6_5_2(M=7) TC_26_12_2_1(M=3,6,9,15) TC_26_12_2_2(M=3,6,10) TC_26_11_2_2_1	INTEGER		Phase 2
TSPX_NoOfHoAccD	number of handover access bursts, value range 5 - 10 TC_26_6_5_1(M=4, 7) TC_26_6_5_2(M=2) TC_26_12_2_1(M=10)	INTEGER		Phase 2
TSPX_NoOfHoAccE	number of handover access bursts, value range 5 - 10 TC_26_6_5_1(M=5) TC_26_6_5_2(M=5) TC_26_12_2_2(M=12)	INTEGER		Phase 2
TSPX_NoOfHoAccF	number of handover access bursts, value range 5 - 10 TC_26_6_5_1(M=6) TC_26_6_5_2(M=10) TC_26_12_2_1(M=14)	INTEGER		Phase 2

Item	Description	Type/Allowed values	Value chosen	Release
TSPX_NoOfHoAccG	number of handover access bursts, value range 2 – 5 TC_26_6_5_2_3	INTEGER		Phase 2
TSPX_NoOfHoAccH	number of handover access bursts, value range 2 - 5 TC_26_6_5_2_4	INTEGER		Phase 2
TSPX_NoOfHoAccI	number of handover access bursts, value range 2 - 5 TC_26_10_2_4_1	INTEGER		Phase 2
TSPX_HoRefA	Hand over reference, GSM 04.08, 10.5.2.15 TC_26_6_5_1(M=1) TC_26_6_5_2(M=1) TC_26_6_5_4_1 TC_26_10_2_4_2 TC_26_12_2_1(M=1,11) TC_26_12_2_2(M=1) TC_26_11_5_1 TC_26_11_5_2	BITSTRING [8]		Phase 2
TSPX_HoRefB	Hand over reference, GSM 04.08, 10.5.2.15 TC_26_6_5_1(M=2, 8) TC_26_6_5_2(M=2) TC_26_12_2_1(M=2,12) TC_26_11_2_2_1	BITSTRING [8]		Phase 2
TSPX_HoRefC	Hand over reference, GSM 04.08, 10.5.2.15 TC_26_6_5_1(M=3) TC_26_6_5_2(M=3) TC_26_12_2_1(M=3,13) TC_26_12_2_2(M=3,6,10) TC_26_11_2_2_1	BITSTRING [8]		Phase 2
TSPX_HoRefD	Hand over reference, GSM 04.08, 10.5.2.15 TC_26_6_5_1(M=4) TC_26_6_5_2(M=4) TC_26_12_2_1(M=4,14)	BITSTRING [8]		Phase 2
TSPX_HoRefE	Hand over reference, GSM 04.08, 10.5.2.15 TC_26_6_5_1(M=5) TC_26_6_5_2(M=5) TC_26_12_2_1(M=5,15)	BITSTRING [8]		Phase 2
TSPX_HoRefF	Hand over reference, GSM 04.08, 10.5.2.15 TC_26_6_5_1(M=6) TC_26_6_5_2(M=6) TC_26_12_2_1(M=6)	BITSTRING [8]		Phase 2
TSPX_HoRefG	Hand over reference, GSM 04.08, 10.5.2.15 TC_26_6_5_1(M=7) TC_26_6_5_2(M=7) TC_26_12_2_1(M=7)	BITSTRING [8]		Phase 2
TSPX_HoRefH	Hand over reference, GSM 04.08, 10.5.2.15 TC_26_6_5_2(M=8) TC_26_12_2_1(M=8)	BITSTRING [8]		Phase 2

Item	Description	Type/Allowed values	Value chosen	Release
TSPX_HoRefI	Hand over reference, GSM 04.08, 10.5.2.15 TC_26_6_5_2(M=9) TC_26_12_2_1(M=9)	BITSTRING [8]		Phase 2
TSPX_HoRefJ	Hand over reference, GSM 04.08, 10.5.2.15 TC_26_6_5_2(M=10) TC_26_12_2_1(M=10)	BITSTRING [8]		Phase 2
TSPX_HSN	Hopping sequence number value range: 0 – 63 (0=Cyclic Hopping)	INTEGER		Phase 2
TSPX_IMSI	IMSI of the MS – Phase 2 Test SIM value - 001010123456063	HEXSTRING		Phase 2
TSPX_Ki	default authentication key used in testing	BITSTRING		Phase 2
TSPX_MAIO	mobile allocation index offset, value range: 0 - 63	INTEGER		Phase 2
TSPX_MaxRetrans	Max-Retrans –Maximum number of re-transmissions of Channel Requests as defined in System Information (values 1, 2, 4 or 7 re- transmissions)	INTEGER		Phase 2
TSPX_MSTxpwrMax	maximum output power from MS GSM 05.05, 4.1.1	0..31		Phase 2
TSPX_PwrlvIA	MS power level, value between 2 to 15 GSM 05.05, 4.1.1	INTEGER		Phase 2
TSPX_PwrlvIB	MS power level, value between 2 to 15 GSM 05.05, 4.1.1	INTEGER		Phase 2
TSPX_PwrlvIC	MS power level, value between 2 to 15 GSM 05.05, 4.1.1	INTEGER		Phase 2
TSPX_PwrlvID	MS power level, value between 2 to 15 GSM 05.05, 4.1.1	INTEGER		Phase 2
TSPX_RANDA	challenge RAND	BITSTRING [128]		Phase 2
TSPX_RANDB	challenge RAND	BITSTRING [128]		Phase 2
TSPX_RANDC	challenge RAND	BITSTRING [128]		Phase 2
TSPX_RANDDef	default challenge RAND	BITSTRING [128]		Phase 2
TSPX_SDCCH4SubA	TDMA offset of SDCCH/4 subchannel	BITSTRING[2]		Phase 2
TSPX_SDCCH4SubB	TDMA offset of SDCCH/4 subchannel	BITSTRING[2]		Phase 2
TSPX_SDCCH4SubC	TDMA offset of SDCCH/4 subchannel	BITSTRING[2]		Phase 2
TSPX_SDCCH4SubDef	TDMA offset of default SDCCH/4 subchannel	BITSTRING[2]		Phase 2
TSPX_SDCCH8SubA	TDMA offset of SDCCH/8 subchannel	BITSTRING[3]		Phase 2
TSPX_SDCCH8SubB	TDMA offset of SDCCH/8 subchannel	BITSTRING[3]		Phase 2
TSPX_SDCCH8SubC	TDMA offset of SDCCH/8 subchannel	BITSTRING[3]		Phase 2

Item	Description	Type/Allowed values	Value chosen	Release
TSPX_SDCCH8SubD	TDMA offset of SDCCH/8 subchannel	BITSTRING[3]		Phase 2
TSPX_SDCCH8SubE	TDMA offset of SDCCH/8 subchannel	BITSTRING[3]		Phase 2
TSPX_SDCCH8SubF	TDMA offset of SDCCH/8 subchannel	BITSTRING[3]		Phase 2
TSPX_SDCCH8SubG	TDMA offset of SDCCH/8 subchannel	BITSTRING[3]		Phase 2
TSPX_SDCCH8SubDef	TDMA offset of default SDCCH/8 subchannel	BITSTRING[3]		Phase 2
TSPX_TimadvA	timing advance in bit periods	INTEGER		Phase 2
TSPX_TimadvB	timing advance in bit periods	INTEGER		Phase 2
TSPX_TimadvC	timing advance in bit periods	INTEGER		Phase 2
TSPX_TmSltA	time slot, GSM 04.08 10.5.2.5	BITSTRING [3]		Phase 2
TSPX_TmSltB	time slot, GSM 04.08 10.5.2.5	BITSTRING [3]		Phase 2
TSPX_TmSltC	time slot, GSM 04.08 10.5.2.5	BITSTRING [3]		Phase 2
TSPX_TmSltD	time slot, GSM 04.08 10.5.2.5	BITSTRING [3]		Phase 2
TSPX_TmSltE	time slot, GSM 04.08 10.5.2.5	BITSTRING [3]		Phase 2
TSPX_TmSltF	time slot, GSM 04.08 10.5.2.5	BITSTRING [3]		Phase 2
TSPX_TmSltG	time slot, GSM 04.08 10.5.2.5	BITSTRING [3]		Phase 2
TSPX_TmSltDef	default time slot, GSM 04.08 10.5.2.5	BITSTRING [3]		Phase 2
TSPX_TmSltNotZero	time slot, arbitrarily value, but not zero.	BITSTRING [3]		Phase 2
TSPX_TmSltNotZero1	time slot, arbitrarily value, but not zero and not TSPX_TmSltNotZero	BITSTRING [3]		Phase 2
TSPX_Txint	Tx-Integer, no of slots to spread transmission (values 3,4,5,6,7,8,9,10,11,12,14,16, 20,25,32 or 50)	INTEGER		Phase 2
TSPX_TscA	training sequence code, GSM 04.08 10.5.2.5	BITSTRING [3]		Phase 2
TSPX_TscB	training sequence code, GSM 04.08 10.5.2.5	BITSTRING [3]		Phase 2
TSPX_TscC	training sequence code, GSM 04.08 10.5.2.5	BITSTRING [3]		Phase 2
TSPX_TscD	training sequence code, GSM 04.08 10.5.2.5	BITSTRING [3]		Phase 2
TSPX_TscE	training sequence code, GSM 04.08 10.5.2.5	BITSTRING [3]		Phase 2
TSPX_TscF	training sequence code, GSM 04.08 10.5.2.5	BITSTRING [3]		Phase 2
TSPX_TscG	training sequence code, GSM 04.08 10.5.2.5	BITSTRING [3]		Phase 2

Item	Description	Type/Allowed values	Value chosen	Release
TSPX_TscDef	default training sequence code, GSM 04.08 10.5.2.5	BITSTRING [3]		Phase 2
TSPX_T3122	value of timer T3122, HEXSTRING[2]	HEXSTRING [2]		Phase 2
TSPX_TCHcarrierA_ho	the value can be chosen arbitrarily from cell allocation of cell A (GSM), but not BCCH carrier .possible value is : 10, 17, 26, 34, 42, 45, 46, 52, 59, 66, 73, 74, 75, 76, 108, 114	INTEGER		Phase 2
TSPX_TCHcarrierA_hod	the value can be chosen arbitrarily from cell allocation of cell A (DCS), but not BCCH carrier . possible value is : 734,741,754,759,762,766,767,773,77 5,779,782,791,798,829,832,844	INTEGER		Phase 2
TSPX_TCHcarrierB	TCH and SDCCH channel frequency number of cell B (GSM)	INTEGER		Phase 2
TSPX_TCHcarrierBd	TCH and SDCCH channel frequency number of cell B (DCS)	INTEGER		Phase 2
TSPX_TCHcarrierB_ho	the value can be chosen arbitrarily from cell allocation of cell B (GSM), but not BCCH carrier . possibles value is : 14,18,22,24,30,31,38,60,66,73,74,75, 76,108,114	INTEGER		Phase 2
TSPX_TCHcarrierB_hod	not BCCH carrier of cell B. the value can be chosen arbitrarily from cell allocation of cell B (DCS), which is (739,743,746,749,756,758,761,771,7 79,782,791,798,829,832,844)	INTEGER		Phase 2
TSPX_TCHcarrierB2_ho	Chosen arbitrarily from cell allocation B for GSM HO cases, but not BCCH carrier!	INTEGER		Phase 2
TSPX_TCHcarrierB2_hod	Chosen arbitrarily from cell allocation B for DCS HO cases, but not BCCH carrier!	INTEGER		Phase 2
TSPX_TCHHSubA	TDMA offset of half rate subchannel	BITSTRING[1]		Phase 2
TSPX_TCHHSubDef	TDMA offset of default half rate subchannel	BITSTRING[1]		Phase 2
TSPX_TMSI	TMSI of the MS used in test	OCTETSTRING[4]		Phase 2
TSPX_TMSI1	another TMSI used in test which shall differ from TSPX_TMSI, TSPX_TMSI + '01'O TSPX_TMSI + '02'O TSPX_TMSI + '03'O	OCTETSTRING[4]		Phase 2
TSPX_k	timing of cell A before cell B k bit periods for TC_26_6_5_1_?, TC_26_6_5_2_?, TC_26_6_5_4_?, TC_26_6_5_3_?.	INTEGER		Phase 2

Item	Description	Type/Allowed values	Value chosen	Release
TSPX_y	timing advance for TC_26_6_5_4_?, TC_26_6_5_3_? TC_26_6_5_5_?, the values of TSPX_k (or TSPX_k1) and TSPX_y shall be $0 < (2 * TSPX_k + TSPX_y) \text{ MOD } 256 < 60$.	INTEGER		Phase 2
TSPX_k1	timing of cell A before cell B k bit periods for TC_26_6_5_5	INTEGER		Phase 2
TSPX_k2	timing of cell A before cell B k bit periods for TC_26_6_5_6	INTEGER		Phase 2
TSPX_y2	timing advance for TC_26_6_5_6, value range : 11 - 62.	INTEGER		Phase 2
TSPX_k3	timing of cell A before cell B k bit periods for TC_26_6_5_7	INTEGER		Phase 2
TSPX_y3	timing advance for TC_26_6_5_7	INTEGER		Phase 2
TSPX_nPara	the n'th ChReq for TC_26_6_1_2, shall be choose to [1..8], MAXRETRANS for TC_26_6_1_2 is 7 (See 11.10 for more explanation).	INTEGER		Phase 2
TSPX_kPara	the k'th ChReq for TC_26_6_1_2 (range 4..8)	INTEGER		Phase 2
TSPX_rPara	the r'th ChReq for TC_26_6_1_2 (range 4..8)	INTEGER		Phase 2
TSPX_i1Para	for TC_26_1_2(TSPX_nPara-3) < TSPX_i1Para <= TSPX_nPara	INTEGER		Phase 2
TSPX_i2Para	for TC_26_1_2 $0 < TSPX_i2Para <= (TSPX_kPara-3)$	INTEGER		Phase 2
TSPX_i3Para	for TC_26_1_2(TSPX_rPara-3) < TSPX_i3Para <= TSPX_rPara	INTEGER		Phase 2
TSPX_n1Para	the n'th ChReq for TC_26_6_1_3 (range 1..8)	INTEGER		Phase 2
TSPX_i4Para	for TC_26_6_1_3 (TSPX_n1Para-3) < TSPX_i4Para <= TSPX_n1Para	INTEGER		Phase 2
TSPX_xPara	t3122 for TC_26_6_1_3 (range 5..255)	INTEGER		Phase 2
TSPX_AGBLKS1	BS-AG-BLKS-RES for TC_26_6_2_3_1, TC_26_6_2_1_1	INTEGER		Phase 2
TSPX_PAMFRMS1	BS-PA-MFRMS for TC_26_6_2_3_1 (shall not be set to 9), TC_26_6_2_1_1	INTEGER		Phase 2
TSPX_CcchConf1	CCCH configuration for TC_26_6_2_3_1, TC_26_6_2_1_1	BITSTRING[3]		Phase 2
TSPX_PgSubch	paging subchannel for TC_26_6_2_3_1	INTEGER		Phase 2
TSPX_AGBLKS2	BS-AG-BLKS-RES for TC_26_6_2_3_2 (range 0..2), TC_26_6_2_1_2	INTEGER		Phase 2
TSPX_PAMFRMS2	BS-PA-MFRMS for TC_26_6_2_3_2, TC_26_6_2_1_2	INTEGER		Phase 2
TSPX_CcchConf2	CCCH configuration for TC_26_6_2_3_2, TC_26_6_2_1_2	BITSTRING[3]		Phase 2

Item	Description	Type/Allowed values	Value chosen	Release
TSPX_AGBLKS3	BS-AG-BLKS-RES for TC_26_6_2_4, TC_26_6_2_2, TC_26_6_2_1_3	INTEGER		Phase 2
TSPX_PAMFRMS3	BS-PA-MFRMS for TC_26_6_2_4, TC_26_6_2_2, TC_26_6_2_1_3	INTEGER		Phase 2
TSPX_CcchConf3	CCCH configuration for TC_26_6_2_4, TC_26_6_2_2, TC_26_6_2_1_3	BITSTRING[3]		Phase 2
TSPX_AGBLKS4	BS-AG-BLKS-RES for TC_26_6_2_5	INTEGER		Phase 2
TSPX_PAMFRMS4	BS-PA-MFRMS for TC_26_6_2_5	INTEGER		Phase 2
TSPX_CcchConf4	CCCH configuration for TC_26_6_2_5 (shall be in the set ('010', '100', '110'))	BITSTRING[3]		Phase 2
TSPX_Chtp1	channel type and TDMA offset for TC_26_6_13_1, any value supported by the MS	BITSTRING[5]		Phase 2
TSPX_ChMod1	channel mode for TC_26_6_13_1, any value for the channel type of TSPX_Chtp1	BITSTRING[8]		Phase 2
TSPX_Maio1	Mobile allocation index offset hopping parameter for TC_26_6_13_1, its value between 0 and (the number of frequencies) -1, which is defined in TSPX_Ma1, default : 2	INTEGER		Phase 2
TSPX_Ma1	mobile allocation (GSM 04.08 10.5.2.21) for TC_26_6_13_1, its value shall indicate number of frequencies between 1 and 17. default : '010101'0	OCTETSTRING[3]		Phase 2
TSPX_Hsn1	hopping sequence number for TC_26_6_13_1. default: 1	INTEGER		Phase 2
TSPX_Maio2	Mobile allocation index offset hopping parameter for TC_26_6_13_1, its value between 0 and (the number of frequencies) -1, which is defined in TSPX_Ma2, default : 8	INTEGER		Phase 2
TSPX_Ma2	mobile allocation for TC_26_6_13_1, its value shall indicate number of frequencies between 1 and 17. default : '01362A'5'0	OCTETSTRING[3]		Phase 2
TSPX_Hsn2	hopping sequence number for TC_26_6_13_1, default : 6	INTEGER		Phase 2
TSPX_Maio3	Mobile allocation index offset hopping parameter for TC_26_6_13_1, its value between 0 and (the number of frequencies) -1, which is defined in TSPX_Ma3, default : 14	INTEGER		Phase 2

Item	Description	Type/Allowed values	Value chosen	Release
TSPX_Ma3	mobile allocation for TC_26_6_13_1, its value shall indicate number of frequencies between 1 and 17. default : '01FFFA'O	OCTETSTRING[3]		Phase 2
TSPX_Hsn3	hopping sequence number for TC_26_6_13_1, default : 0	INTEGER		Phase 2
TSPX_Chtp2	channel type for TC_26_6_13_2, any value supported by the MS	BITSTRING[5]		Phase 2
TSPX_ChMod2	channel mode for TC_26_6_13_2	BITSTRING[8]		Phase 2
TSPX_Maio4	Mobile allocation index offset hopping parameter for TC_26_6_13_2, its value between 0 and (the number of frequencies) -1, which is defined in TSPX_Ma4, default : 3	INTEGER		Phase 2
TSPX_Ma4	mobile allocation for TC_26_6_13_2, its value shall indicate number of frequencies between 1 and 17. default : '001141'O	OCTETSTRING[3]		Phase 2
TSPX_Hsn4	hopping sequence number for TC_26_6_13_2, default : 0	INTEGER		Phase 2
TSPX_Maio5	Mobile allocation index offset hopping parameter for TC_26_6_13_2, its value between 0 and (the number of frequencies) -1, which is defined in TSPX_Ma5, default : 9	INTEGER		Phase 2
TSPX_Ma5	mobile allocation for TC_26_6_13_2, its value shall indicate number of frequencies between 1 and 17. default : '01ABCB'O	OCTETSTRING[3]		Phase 2
TSPX_Hsn5	hopping sequence number for TC_26_6_13_2, default : 16	INTEGER		Phase 2
TSPX_Chtp3	channel type for TC_26_6_13_3, any value supported by the MS	BITSTRING[5]		Phase 2
TSPX_Maio6	Mobile allocation index offset hopping parameter for TC_26_6_13_3, its value between 0 and (the number of frequencies) -1, which is defined in TSPX_Ma6, default : 4	INTEGER		Phase 2
TSPX_Ma6	mobile allocation for TC_26_6_13_3, its value shall indicate number of frequencies between 1 and 17. default : '006248'O	OCTETSTRING[3]		Phase 2
TSPX_Hsn6	hopping sequence number for TC_26_6_13_3, default : 4	INTEGER		Phase 2

Item	Description	Type/Allowed values	Value chosen	Release
TSPX_Maio7	Mobile allocation index offset hopping parameter for TC_26_6_13_3, its value between 0 and (the number of frequencies) -1, which is defined in TSPX_Ma7, default : 10	INTEGER		Phase 2
TSPX_Ma7	mobile allocation for TC_26_6_13_3, its value shall indicate number of frequencies between 2 and 17. default : '009AFB'O	OCTETSTRING[3]		Phase 2
TSPX_Chtp4	channel type for TC_26_6_13_3, any value supported by the MS	BITSTRING[5]		Phase 2
TSPX_Maio8	Mobile allocation index offset hopping parameter for TC_26_6_13_3, its value between 0 and (the number of frequencies) -1, which is defined in TSPX_Ma8, default : 1	INTEGER		Phase 2
TSPX_Ma8	mobile allocation for TC_26_6_13_3, its value shall indicate number of frequencies between 2 and 17. default : '002800'O	OCTETSTRING[3]		Phase 2
TSPX_Hsn8	hopping sequence number for TC_26_6_13_3, default : 40	INTEGER		Phase 2
TSPX_Maio9	Mobile allocation index offset hopping parameter for TC_26_6_13_3, its value between 0 and (the number of frequencies) -1, which is defined in TSPX_Ma9, default : 15	INTEGER		Phase 2
TSPX_Ma9	mobile allocation for TC_26_6_13_3, its value shall indicate number of frequencies between 2 and 17. default : '01FFFB'O	OCTETSTRING[3]		Phase 2
TSPX_Hsn9	hopping sequence number for TC_26_6_13_3, default : 8	INTEGER		Phase 2
TSPX_Chtp5	SDDCH8 subchannel immediately assigned in TC_26_6_13_4	BITSTRING[5]		Phase 2
TSPX_Maio10	Mobile allocation index offset hopping parameter for TC_26_6_13_4, its value between 0 and (the number of frequencies) -1, which is defined in TSPX_Ma10, default : 5	INTEGER		Phase 2
TSPX_Ma10	mobile allocation for TC_26_6_13_4, its value shall indicate number of frequencies between 1 and 17. default : '01D082'O	OCTETSTRING[3]		Phase 2
TSPX_Hsn10	hopping sequence number for TC_26_6_13_4, default: 0	INTEGER		Phase 2

Item	Description	Type/Allowed values	Value chosen	Release
TSPX_Maio11	Mobile allocation index offset hopping parameter for TC_26_6_13_4, its value between 0 and (the number of frequencies) -1, which is defined in TSPX_Ma11, default : 11	INTEGER		Phase 2
TSPX_Ma11	mobile allocation for TC_26_6_13_4, its value shall indicate number of frequencies between 2 and 17. default : '00CFF3'O	OCTETSTRING[3]		Phase 2
TSPX_Chtp6	channel type of a non existing channel in the Assignment Command for TC_26_6_13_4	BITSTRING[5]		Phase 2
TSPX_Maio12	Mobile allocation index offset hopping parameter for TC_26_6_13_4, its value between 0 and (the number of frequencies) -1, which is defined in TSPX_Ma12, default : 1	INTEGER		Phase 2
TSPX_Ma12	mobile allocation for TC_26_6_13_4, its value shall indicate number of frequencies between 1 and 17. default : '010100'O	OCTETSTRING[3]		Phase 2
TSPX_Hsn12	hopping sequence number for TC_26_6_13_4, default : 39	INTEGER		Phase 2
TSPX_Maio13	Mobile allocation index offset hopping parameter for TC_26_6_13_4, its value between 0 and (the number of frequencies) -1, which is defined in TSPX_Ma13, default : 6	INTEGER		Phase 2
TSPX_Ma13	mobile allocation for TC_26_6_13_4, its value shall indicate number of frequencies between 1 and 17. default : '00E690'O	OCTETSTRING[3]		Phase 2
TSPX_Hsn13	hopping sequence number for TC_26_6_13_4, default: 42	INTEGER		Phase 2
TSPX_Chtp7	channel type for TC_26_6_13_5	BITSTRING[5]		Phase 2
TSPX_ChMod4	channel mode for TC_26_6_13_5	BITSTRING[8]		Phase 2
TSPX_Maio14	Mobile allocation index offset hopping parameter for TC_26_6_13_5, its value between 0 and (the number of frequencies) -1, which is defined in TSPX_Ma14, default : 4	INTEGER		Phase 2
TSPX_Ma14	mobile allocation for TC_26_6_13_5, its value shall indicate number of frequencies between 1 and 17. default : '004A28'O	OCTETSTRING[3]		Phase 2

Item	Description	Type/Allowed values	Value chosen	Release
TSPX_Hsn14	hopping sequence number for TC_26_6_13_5, default : 50	INTEGER		Phase 2
TSPX_Maio15	Mobile allocation index offset hopping parameter for TC_26_6_13_5, its value between 0 and (the number of frequencies) -1, which is defined in TSPX_Ma15, default : 12	INTEGER		Phase 2
TSPX_Ma15	mobile allocation for TC_26_6_13_5, its value shall indicate number of frequencies between 1 and 16. default : '00FF79'0	OCTETSTRING[3]		Phase 2
TSPX_Hsn15	hopping sequence number for TC_26_6_13_5, default : 33	INTEGER		Phase 2
TSPX_Maio16	Mobile allocation index offset hopping parameter for TC_26_6_13_5, its value between 0 and (the number of frequencies) -1, which is defined in TSPX_Ma16, default : 2	INTEGER		Phase 2
TSPX_Ma16	mobile allocation for TC_26_6_13_5, its value shall indicate number of frequencies between 1 and 16. default : '001110'0	OCTETSTRING[3]		Phase 2
TSPX_Hsn16	hopping sequence number for TC_26_6_13_5, default : 21	INTEGER		Phase 2
TSPX_Chtp8	channel type for TC_26_6_13_6	BITSTRING[5]		Phase 2
TSPX_ChMod5	channel mode for TC_26_6_13_6	BITSTRING[8]		Phase 2
TSPX_Maio17	Mobile allocation index offset hopping parameter for TC_26_6_13_6, its value between 0 and (the number of frequencies) -1, which is defined in TSPX_Ma17, default : 7	INTEGER		Phase 2
TSPX_Ma17	mobile allocation for TC_26_6_13_6, its value shall indicate number of frequencies between 1 and 17. default : '00E6A1'0	OCTETSTRING[3]		Phase 2
TSPX_Hsn17	hopping sequence number for TC_26_6_13_6, default : 22	INTEGER		Phase 2
TSPX_Maio18	Mobile allocation index offset hopping parameter for TC_26_6_13_6, its value between 0 and (the number of frequencies) -1, which is defined in TSPX_Ma18, default : 13	INTEGER		Phase 2
TSPX_Ma18	mobile allocation for TC_26_6_13_6, its value shall indicate number of frequencies between 1 and 16. default : '00FFF9'0	OCTETSTRING[3]		Phase 2

Item	Description	Type/Allowed values	Value chosen	Release
TSPX_Hsn18	hopping sequence number for TC_26_6_13_6, default : 9	INTEGER		Phase 2
TSPX_Maio19	Mobile allocation index offset hopping parameter for TC_26_6_13_6, its value between 0 and (the number of frequencies) -1, which is defined in TSPX_Ma19, default : 3	INTEGER		Phase 2
TSPX_Ma19	mobile allocation for TC_26_6_13_6, its value shall indicate number of frequencies between 1 and 16. default : '001111'O	OCTETSTRING[3]		Phase 2
TSPX_Hsn19	hopping sequence number for TC_26_6_13_6, default : 44	INTEGER		Phase 2
TSPX_Chtp9	channel type for TC_26_6_13_7	BITSTRING[5]		Phase 2
TSPX_ChMod6	channel mode for TC_26_6_13_7	BITSTRING[8]		Phase 2
TSPX_Maio20	Mobile allocation index offset hopping parameter for TC_26_6_13_7, its value between 0 and (the number of frequencies) -1, which is defined in TSPX_Ma20, default : 8	INTEGER		Phase 2
TSPX_Ma20	mobile allocation for TC_26_6_13_7, its value shall indicate number of frequencies between 1 and 17. default : '016699'O	OCTETSTRING[3]		Phase 2
TSPX_Hsn20	hopping sequence number for TC_26_6_13_7, default : 30	INTEGER		Phase 2
TSPX_Maio21	Mobile allocation index offset hopping parameter for TC_26_6_13_7, its value between 0 and (the number of frequencies) -1, which is defined in TSPX_Ma21, default : 14	INTEGER		Phase 2
TSPX_Ma21	mobile allocation for TC_26_6_13_7, its value shall indicate number of frequencies between 1 and 17. default : '01FEFB'O	OCTETSTRING[3]		Phase 2
TSPX_Chtp10	channel type for TC_26_6_13_7	BITSTRING[5]		Phase 2
TSPX_Maio22	Mobile allocation index offset hopping parameter for TC_26_6_13_7, its value between 0 and (the number of frequencies) -1, which is defined in TSPX_Ma22, default : 4	INTEGER		Phase 2
TSPX_Ma22	mobile allocation for TC_26_6_13_7, its value shall indicate number of frequencies between 1 and 16. default : '006241'O	OCTETSTRING[3]		Phase 2

Item	Description	Type/Allowed values	Value chosen	Release
TSPX_Hsn22	hopping sequence number for TC_26_6_13_7, default : 11	INTEGER		Phase 2
TSPX_Maio23	Mobile allocation index offset hopping parameter for TC_26_6_13_7, its value between 0 and (the number of frequencies) -1, which is defined in TSPX_Ma23, default : 11	INTEGER		Phase 2
TSPX_Ma23	mobile allocation for TC_26_6_13_7, its value shall indicate number of frequencies between 1 and 16. default : '00FF1B'O	OCTETSTRING[3]		Phase 2
TSPX_Hsn23	hopping sequence number for TC_26_6_13_7, default : 60	INTEGER		Phase 2
TSPX_Chtp11	SDCCH8 subchannel immediately assigned, TC_26_6_13_8	BITSTRING[5]		Phase 2
TSPX_ChMod7	channel mode for TC_26_6_13_8	BITSTRING[8]		Phase 2
TSPX_Maio24	Mobile allocation index offset hopping parameter for TC_26_6_13_8, its value between 0 and (the number of frequencies) -1, which is defined in TSPX_Ma24, default : 9	INTEGER		Phase 2
TSPX_Ma24	mobile allocation for TC_26_6_13_8, its value shall indicate number of frequencies between 1 and 17. default : '00E6E9'O	OCTETSTRING[3]		Phase 2
TSPX_Hsn24	hopping sequence number for TC_26_6_13_8, default : 7	INTEGER		Phase 2
TSPX_Maio25	Mobile allocation index offset hopping parameter for TC_26_6_13_8, its value between 0 and (the number of frequencies) -1, which is defined in TSPX_Ma25, default : 15	INTEGER		Phase 2
TSPX_Ma25	mobile allocation for TC_26_6_13_8, its value shall indicate number of frequencies between 1 and 17. default : '01FFFB'O	OCTETSTRING[3]		Phase 2
TSPX_Chtp12	channel type of a non-existing channel in the Assignment Command for TC_26_6_13_8	BITSTRING[5]		Phase 2
TSPX_Maio26	Mobile allocation index offset hopping parameter for TC_26_6_13_8, its value between 0 and (the number of frequencies) -1, which is defined in TSPX_Ma26, default : 5	INTEGER		Phase 2

Item	Description	Type/Allowed values	Value chosen	Release
TSPX_Ma26	mobile allocation for TC_26_6_13_8, its value shall indicate number of frequencies between 1 and 16. default : '009168'O	OCTETSTRING[3]		Phase 2
TSPX_Hsn26	hopping sequence number for TC_26_6_13_8, default : 9	INTEGER		Phase 2
TSPX_Maio27	Mobile allocation index offset hopping parameter for TC_26_6_13_8, its value between 0 and (the number of frequencies) -1, which is defined in TSPX_Ma27, default : 1	INTEGER		Phase 2
TSPX_Ma27	mobile allocation for TC_26_6_13_8, its value shall indicate number of frequencies between 1 and 16. default : '004080'O	OCTETSTRING[3]		Phase 2
TSPX_Hsn27	hopping sequence number for TC_26_6_13_8, default : 38	INTEGER		Phase 2
TSPX_Chtp13	channel type for TC_26_6_13_9	BITSTRING[5]		Phase 2
TSPX_Tm3	Timer for TC_26_6_13_9, value between 60 -100	INTEGER		Phase 2
TSPX_Maio28	Mobile allocation index offset hopping parameter for TC_26_6_13_9, its value between 0 and (the number of frequencies) -1, which is defined in TSPX_Ma28, default : 10	INTEGER		Phase 2
TSPX_Ma28	mobile allocation for TC_26_6_13_9, its value shall indicate number of frequencies between 1 and 17. default : '00EE7A'O	OCTETSTRING[3]		Phase 2
TSPX_Hsn28	hopping sequence number for TC_26_6_13_9, default : 11	INTEGER		Phase 2
TSPX_Maio29	Mobile allocation index offset hopping parameter for TC_26_6_13_9, its value between 0 and (the number of frequencies) -1, which is defined in TSPX_Ma29, default : 6	INTEGER		Phase 2
TSPX_Ma29	mobile allocation for TC_26_6_13_9, its value shall indicate number of frequencies between 1 and 17. default : '00F070'O	OCTETSTRING[3]		Phase 2
TSPX_Chtp14	channel type for TC_26_6_13_10	BITSTRING[5]		Phase 2
TSPX_Maio30	Mobile allocation index offset hopping parameter for TC_26_6_13_10, its value between 0 and (the number of frequencies) -1, which is defined in TSPX_Ma30, default : 11	INTEGER		Phase 2

Item	Description	Type/Allowed values	Value chosen	Release
TSPX_Ma30	mobile allocation for TC_26_6_13_10, its value shall indicate number of frequencies between 1 and 17. default : '017F69'0	OCTETSTRING[3]		Phase 2
TSPX_Hsn30	hopping sequence number for TC_26_6_13_10, default : 62	INTEGER		Phase 2
TSPX_Maio31	Mobile allocation index offset hopping parameter for TC_26_6_13_10, its value between 0 and (the number of frequencies) -1, which is defined in TSPX_Ma31, default : 1	INTEGER		Phase 2
TSPX_Ma31	mobile allocation for TC_26_6_13_10, its value shall indicate number of frequencies between 1 and 17. default : '000101'0	OCTETSTRING[3]		Phase 2
TSPX_MOBscSvcA	any supported MO basic service	"C_Telephony", "C_EngCallSRV", "C_AltSpchG3", "C_AutoG3", "C_300cda", "C_1200cda", "C_120075cda", "C_2400cda", "C_4800cda", "C_2400cda", "C_4800cda", "C_2400cda", "C_4800cda", "C_PAD300", "C_PAD1200", "C_PAD120075", "C_PAD2400", "C_PAD4800", "C_PAD9600", "C_Pkt2400", "C_Pkt4800", "C_Pkt9600", "C_AltSpchData", "C_SpchData"		Phase 2

Item	Description	Type/Allowed values	Value chosen	Release
TSPX_MOBscSvcB	any supported MO basic service	"C_Telephony", "C_EmgCallSRV", "C_AltSpchG3", "C_AutoG3", "C_300cda", "C_1200cda", "C_120075cda", "C_2400cda", "C_4800cda", "C_2400cda", "C_4800cda", "C_2400cda", "C_4800cda", "C_PAD300", "C_PAD1200", "C_PAD120075", "C_PAD2400", "C_PAD4800", "C_PAD9600", "C_Pkt2400", "C_Pkt4800", "C_Pkt9600", "C_AltSpchData", "C_SpchData"		Phase 2
TSPX_MOBscSvcC	any supported MO basic service	"C_Telephony", "C_EmgCallSRV", "C_AltSpchG3", "C_AutoG3", "C_300cda", "C_1200cda", "C_120075cda", "C_2400cda", "C_4800cda", "C_2400cda", "C_4800cda", "C_2400cda", "C_4800cda", "C_PAD300", "C_PAD1200", "C_PAD120075", "C_PAD2400", "C_PAD4800", "C_PAD9600", "C_Pkt2400", "C_Pkt4800", "C_Pkt9600", "C_AltSpchData", "C_SpchData"		Phase 2

Item	Description	Type/Allowed values	Value chosen	Release
TSPX_MOBscSvcD	any supported MO basic service	"C_Telephony", "C_EmgCallSRV", "C_AltSpchG3", "C_AutoG3", "C_300cda", "C_1200cda", "C_120075cda", "C_2400cda", "C_4800cda", "C_2400cda", "C_4800cda", "C_2400cda", "C_4800cda", "C_PAD300", "C_PAD1200", "C_PAD120075", "C_PAD2400", "C_PAD4800", "C_PAD9600", "C_Pkt2400", "C_Pkt4800", "C_Pkt9600", "C_AltSpchData", "C_SpchData"		Phase 2
TSPX_MOBscSvcE	any supported MO basic service	"C_Telephony", "C_EmgCallSRV", "C_AltSpchG3", "C_AutoG3", "C_300cda", "C_1200cda", "C_120075cda", "C_2400cda", "C_4800cda", "C_2400cda", "C_4800cda", "C_2400cda", "C_4800cda", "C_PAD300", "C_PAD1200", "C_PAD120075", "C_PAD2400", "C_PAD4800", "C_PAD9600", "C_Pkt2400", "C_Pkt4800", "C_Pkt9600", "C_AltSpchData", "C_SpchData"		Phase 2

Item	Description	Type/Allowed values	Value chosen	Release
TSPX_MOBscSvcF	any supported MO basic service	"C_Telephony", "C_EmgCallSRV", "C_AltSpchG3", "C_AutoG3", "C_300cda", "C_1200cda", "C_120075cda", "C_2400cda", "C_4800cda", "C_2400cda", "C_4800cda", "C_2400cda", "C_4800cda", "C_PAD300", "C_PAD1200", "C_PAD120075", "C_PAD2400", "C_PAD4800", "C_PAD9600", "C_Pkt2400", "C_Pkt4800", "C_Pkt9600", "C_AltSpchData", "C_SpchData"		Phase 2
TSPX_MOBscSvcG	any supported MO basic service	"C_Telephony", "C_EmgCallSRV", "C_AltSpchG3", "C_AutoG3", "C_300cda", "C_1200cda", "C_120075cda", "C_2400cda", "C_4800cda", "C_2400cda", "C_4800cda", "C_2400cda", "C_4800cda", "C_PAD300", "C_PAD1200", "C_PAD120075", "C_PAD2400", "C_PAD4800", "C_PAD9600", "C_Pkt2400", "C_Pkt4800", "C_Pkt9600", "C_AltSpchData", "C_SpchData"		Phase 2

Item	Description	Type/Allowed values	Value chosen	Release
TSPX_MOBscSvcH	any supported MO basic service	"C_Telephony", "C_EmgCallSRV", "C_AltSpchG3", "C_AutoG3", "C_300cda", "C_1200cda", "C_120075cda", "C_2400cda", "C_4800cda", "C_2400cda", "C_4800cda", "C_2400cda", "C_4800cda", "C_PAD300", "C_PAD1200", "C_PAD120075", "C_PAD2400", "C_PAD4800", "C_PAD9600", "C_Pkt2400", "C_Pkt4800", "C_Pkt9600", "C_AltSpchData", "C_SpchData"		Phase 2
TSPX_MOBscSvcI	any supported MO basic service	"C_Telephony", "C_EmgCallSRV", "C_AltSpchG3", "C_AutoG3", "C_300cda", "C_1200cda", "C_120075cda", "C_2400cda", "C_4800cda", "C_2400cda", "C_4800cda", "C_2400cda", "C_4800cda", "C_PAD300", "C_PAD1200", "C_PAD120075", "C_PAD2400", "C_PAD4800", "C_PAD9600", "C_Pkt2400", "C_Pkt4800", "C_Pkt9600", "C_AltSpchData", "C_SpchData"		Phase 2

Item	Description	Type/Allowed values	Value chosen	Release
TSPX_MOBscSvcJ	any supported MO basic service	"C_Telephony", "C_EmgCallSRV", "C_AltSpchG3", "C_AutoG3", "C_300cda", "C_1200cda", "C_120075cda", "C_2400cda", "C_4800cda", "C_2400cda", "C_4800cda", "C_2400cda", "C_4800cda", "C_PAD300", "C_PAD1200", "C_PAD120075", "C_PAD2400", "C_PAD4800", "C_PAD9600", "C_Pkt2400", "C_Pkt4800", "C_Pkt9600", "C_AltSpchData", "C_SpchData"		Phase 2
TSPX_MT_DualModSvc	any supported MT dual mode service	"C_Telephony", "C_EmgCallSRV", "C_AltSpchG3", "C_AutoG3", "C_300cda", "C_1200cda", "C_120075cda", "C_2400cda", "C_4800cda", "C_2400cda", "C_4800cda", "C_2400cda", "C_4800cda", "C_PAD300", "C_PAD1200", "C_PAD120075", "C_PAD2400", "C_PAD4800", "C_PAD9600", "C_Pkt2400", "C_Pkt4800", "C_Pkt9600", "C_AltSpchData", "C_SpchData"		Phase 2

Item	Description	Type/Allowed values	Value chosen	Release
TSPX_MT_NonSptSvc	any not supported MT basic service	"C_Telephony", "C_EmgCallSRV", "C_AltSpchG3", "C_AutoG3", "C_300cda", "C_1200cda", "C_120075cda", "C_2400cda", "C_4800cda", "C_2400cds", "C_4800cds", "C_PAD300", "C_PAD1200", "C_PAD120075", "C_PAD2400", "C_PAD4800", "C_PAD9600", "C_Pkt2400", "C_Pkt4800", "C_Pkt9600", "C_AltSpchData", "C_SpchData"		Phase 2
TSPX_MTBscSvcA	any supported MT basic service	"C_Telephony", "C_EmgCallSRV", "C_AltSpchG3", "C_AutoG3", "C_300cda", "C_1200cda", "C_120075cda", "C_2400cda", "C_4800cda", "C_2400cds", "C_4800cds", "C_PAD300", "C_PAD1200", "C_PAD120075", "C_PAD2400", "C_PAD4800", "C_PAD9600", "C_Pkt2400", "C_Pkt4800", "C_Pkt9600", "C_AltSpchData", "C_SpchData"		Phase 2

Item	Description	Type/Allowed values	Value chosen	Release
TSPX_MTBscSvcB	any supported MT basic service	"C_Telephony", "C_EmgCallSRV", "C_AltSpchG3", "C_AutoG3", "C_300cda", "C_1200cda", "C_120075cda", "C_2400cda", "C_4800cda", "C_2400cda", "C_4800cda", "C_2400cda", "C_4800cda", "C_PAD300", "C_PAD1200", "C_PAD120075", "C_PAD2400", "C_PAD4800", "C_PAD9600", "C_Pkt2400", "C_Pkt4800", "C_Pkt9600", "C_AltSpchData", "C_SpchData"		Phase 2
TSPX_MTBscSvcC	any supported MT basic service	"C_Telephony", "C_EmgCallSRV", "C_AltSpchG3", "C_AutoG3", "C_300cda", "C_1200cda", "C_120075cda", "C_2400cda", "C_4800cda", "C_2400cda", "C_4800cda", "C_2400cda", "C_4800cda", "C_PAD300", "C_PAD1200", "C_PAD120075", "C_PAD2400", "C_PAD4800", "C_PAD9600", "C_Pkt2400", "C_Pkt4800", "C_Pkt9600", "C_AltSpchData", "C_SpchData"		Phase 2

Item	Description	Type/Allowed values	Value chosen	Release
TSPX_MTBscSvcD	any supported MT basic service	"C_Telephony", "C_EmgCallSRV", "C_AltSpchG3", "C_AutoG3", "C_300cda", "C_1200cda", "C_120075cda", "C_2400cda", "C_4800cda", "C_2400cda", "C_4800cda", "C_2400cda", "C_4800cda", "C_PAD300", "C_PAD1200", "C_PAD120075", "C_PAD2400", "C_PAD4800", "C_PAD9600", "C_Pkt2400", "C_Pkt4800", "C_Pkt9600", "C_AltSpchData", "C_SpchData"		Phase 2
TSPX_MTBscSvcE	any supported MT basic service	"C_Telephony", "C_EmgCallSRV", "C_AltSpchG3", "C_AutoG3", "C_300cda", "C_1200cda", "C_120075cda", "C_2400cda", "C_4800cda", "C_2400cda", "C_4800cda", "C_2400cda", "C_4800cda", "C_PAD300", "C_PAD1200", "C_PAD120075", "C_PAD2400", "C_PAD4800", "C_PAD9600", "C_Pkt2400", "C_Pkt4800", "C_Pkt9600", "C_AltSpchData", "C_SpchData"		Phase 2

Item	Description	Type/Allowed values	Value chosen	Release
TSPX_MTBscSvcF	any supported MT basic service	"C_Telephony", "C_EmgCallSRV", "C_AltSpchG3", "C_AutoG3", "C_300cda", "C_1200cda", "C_120075cda", "C_2400cda", "C_4800cda", "C_2400cds", "C_4800cds", "C_PAD300", "C_PAD1200", "C_PAD120075", "C_PAD2400", "C_PAD4800", "C_PAD9600", "C_Pkt2400", "C_Pkt4800", "C_Pkt9600", "C_AltSpchData", "C_SpchData"		Phase 2
TSPX_MTBscSvcG	any supported MT basic service	"C_Telephony", "C_EmgCallSRV", "C_AltSpchG3", "C_AutoG3", "C_300cda", "C_1200cda", "C_120075cda", "C_2400cda", "C_4800cda", "C_2400cds", "C_4800cds", "C_PAD300", "C_PAD1200", "C_PAD120075", "C_PAD2400", "C_PAD4800", "C_PAD9600", "C_Pkt2400", "C_Pkt4800", "C_Pkt9600", "C_AltSpchData", "C_SpchData"		Phase 2

Item	Description	Type/Allowed values	Value chosen	Release
TSPX_MTBscSvcH	any supported MT basic service	"C_Telephony", "C_EmgCallSRV", "C_AltSpchG3", "C_AutoG3", "C_300cda", "C_1200cda", "C_120075cda", "C_2400cda", "C_4800cda", "C_2400cda", "C_4800cda", "C_2400cda", "C_4800cda", "C_PAD300", "C_PAD1200", "C_PAD120075", "C_PAD2400", "C_PAD4800", "C_PAD9600", "C_Pkt2400", "C_Pkt4800", "C_Pkt9600", "C_AltSpchData", "C_SpchData"		Phase 2
TSPX_MTBscSvcI	any supported MT basic service	"C_Telephony", "C_EmgCallSRV", "C_AltSpchG3", "C_AutoG3", "C_300cda", "C_1200cda", "C_120075cda", "C_2400cda", "C_4800cda", "C_2400cda", "C_4800cda", "C_2400cda", "C_4800cda", "C_PAD300", "C_PAD1200", "C_PAD120075", "C_PAD2400", "C_PAD4800", "C_PAD9600", "C_Pkt2400", "C_Pkt4800", "C_Pkt9600", "C_AltSpchData", "C_SpchData"		Phase 2

Item	Description	Type/Allowed values	Value chosen	Release
TSPX_MTBscSvcJ	any supported MT basic service	"C_Telephony", "C_EmgCallSRV", "C_AltSpchG3", "C_AutoG3", "C_300cda", "C_1200cda", "C_120075cda", "C_2400cda", "C_4800cda", "C_2400cda", "C_4800cda", "C_2400cda", "C_4800cda", "C_PAD300", "C_PAD1200", "C_PAD120075", "C_PAD2400", "C_PAD4800", "C_PAD9600", "C_Pkt2400", "C_Pkt4800", "C_Pkt9600", "C_AltSpchData", "C_SpchData"		Phase 2
TSPX_MTNIC_BscSvcA	any supported MT basic service without immediate connection	"C_Telephony", "C_EmgCallSRV", "C_AltSpchG3", "C_AutoG3", "C_300cda", "C_1200cda", "C_120075cda", "C_2400cda", "C_4800cda", "C_2400cda", "C_4800cda", "C_2400cda", "C_4800cda", "C_PAD300", "C_PAD1200", "C_PAD120075", "C_PAD2400", "C_PAD4800", "C_PAD9600", "C_Pkt2400", "C_Pkt4800", "C_Pkt9600", "C_AltSpchData", "C_SpchData"		Phase 2

Item	Description	Type/Allowed values	Value chosen	Release
TSPX_MTNIC_BscSvcB	any supported MT basic service without immediate connection	"C_Telephony", "C_EmgCallSRV", "C_AltSpchG3", "C_AutoG3", "C_300cda", "C_1200cda", "C_120075cda", "C_2400cda", "C_4800cda", "C_2400cds", "C_4800cds", "C_PAD300", "C_PAD1200", "C_PAD120075", "C_PAD2400", "C_PAD4800", "C_PAD9600", "C_Pkt2400", "C_Pkt4800", "C_Pkt9600", "C_AltSpchData", "C_SpchData"		Phase 2
TSPX_MTNIC_BscSvcC	any supported MT basic service without immediate connection	"C_Telephony", "C_EmgCallSRV", "C_AltSpchG3", "C_AutoG3", "C_300cda", "C_1200cda", "C_120075cda", "C_2400cda", "C_4800cda", "C_2400cds", "C_4800cds", "C_PAD300", "C_PAD1200", "C_PAD120075", "C_PAD2400", "C_PAD4800", "C_PAD9600", "C_Pkt2400", "C_Pkt4800", "C_Pkt9600", "C_AltSpchData", "C_SpchData"		Phase 2

Item	Description	Type/Allowed values	Value chosen	Release
TSPX_MTNIC_BscSvcD	any supported MT basic service without immediate connection	"C_Telephony", "C_EmgCallSRV", "C_AltSpchG3", "C_AutoG3", "C_300cda", "C_1200cda", "C_120075cda", "C_2400cda", "C_4800cda", "C_2400cda", "C_4800cda", "C_2400cda", "C_4800cda", "C_PAD300", "C_PAD1200", "C_PAD120075", "C_PAD2400", "C_PAD4800", "C_PAD9600", "C_Pkt2400", "C_Pkt4800", "C_Pkt9600", "C_AltSpchData", "C_SpchData"		Phase 2
TSPX_MTNIC_BscSvcE	any supported MT basic service without immediate connection	"C_Telephony", "C_EmgCallSRV", "C_AltSpchG3", "C_AutoG3", "C_300cda", "C_1200cda", "C_120075cda", "C_2400cda", "C_4800cda", "C_2400cda", "C_4800cda", "C_2400cda", "C_4800cda", "C_PAD300", "C_PAD1200", "C_PAD120075", "C_PAD2400", "C_PAD4800", "C_PAD9600", "C_Pkt2400", "C_Pkt4800", "C_Pkt9600", "C_AltSpchData", "C_SpchData"		Phase 2

Item	Description	Type/Allowed values	Value chosen	Release
TSPX_MTNIC_BscSvcF	any supported MT basic service without immediate connection	"C_Telephony", "C_EmgCallSRV", "C_AltSpchG3", "C_AutoG3", "C_300cda", "C_1200cda", "C_120075cda", "C_2400cda", "C_4800cda", "C_2400cda", "C_4800cda", "C_2400cda", "C_4800cda", "C_PAD300", "C_PAD1200", "C_PAD120075", "C_PAD2400", "C_PAD4800", "C_PAD9600", "C_Pkt2400", "C_Pkt4800", "C_Pkt9600", "C_AltSpchData", "C_SpchData"		Phase 2
TSPX_MTNIC_BscSvcG	any supported MT basic service without immediate connection	"C_Telephony", "C_EmgCallSRV", "C_AltSpchG3", "C_AutoG3", "C_300cda", "C_1200cda", "C_120075cda", "C_2400cda", "C_4800cda", "C_2400cda", "C_4800cda", "C_2400cda", "C_4800cda", "C_PAD300", "C_PAD1200", "C_PAD120075", "C_PAD2400", "C_PAD4800", "C_PAD9600", "C_Pkt2400", "C_Pkt4800", "C_Pkt9600", "C_AltSpchData", "C_SpchData"		Phase 2

Item	Description	Type/Allowed values	Value chosen	Release
TSPX_MTNIC_BscSvcH	any supported MT basic service without immediate connection	"C_Telephony", "C_EmgCallSRV", "C_AltSpchG3", "C_AutoG3", "C_300cda", "C_1200cda", "C_120075cda", "C_2400cda", "C_4800cda", "C_2400cda", "C_4800cda", "C_2400cda", "C_4800cda", "C_PAD300", "C_PAD1200", "C_PAD120075", "C_PAD2400", "C_PAD4800", "C_PAD9600", "C_Pkt2400", "C_Pkt4800", "C_Pkt9600", "C_AltSpchData", "C_SpchData"		Phase 2
TSPX_MTNIC_BscSvcI	any supported MT basic service without immediate connection	"C_Telephony", "C_EmgCallSRV", "C_AltSpchG3", "C_AutoG3", "C_300cda", "C_1200cda", "C_120075cda", "C_2400cda", "C_4800cda", "C_2400cda", "C_4800cda", "C_2400cda", "C_4800cda", "C_PAD300", "C_PAD1200", "C_PAD120075", "C_PAD2400", "C_PAD4800", "C_PAD9600", "C_Pkt2400", "C_Pkt4800", "C_Pkt9600", "C_AltSpchData", "C_SpchData"		Phase 2

Item	Description	Type/Allowed values	Value chosen	Release
TSPX_MTNIC_BscSvcJ	any supported MT basic service without immediate connection	"C_Telephony", "C_EmgCallSRV", "C_AltSpchG3", "C_AutoG3", "C_300cda", "C_1200cda", "C_120075cda", "C_2400cda", "C_4800cda", "C_2400cda", "C_4800cda", "C_2400cda", "C_4800cda", "C_2400cda", "C_4800cda", "C_PAD300", "C_PAD1200", "C_PAD120075", "C_PAD2400", "C_PAD4800", "C_PAD9600", "C_Pkt2400", "C_Pkt4800", "C_Pkt9600", "C_AltSpchData", "C_SpchData"		Phase 2
TSPX_Telephony_Rate	channel rate for TS11 (telephony), default value : "F"	"F", "H"		Phase 2
TSPX_MOChRateA	channel rate for TSPX_MOBscSvcA, default value : "F"	"F", "H"		Phase 2
TSPX_MOChRateB	channel rate for TSPX_MOBscSvcB, default value : "F"	"F", "H"		Phase 2
TSPX_MOChRateC	channel rate for TSPX_MOBscSvcC, default value : "F"	"F", "H"		Phase 2
TSPX_MOChRateD	channel rate for TSPX_MOBscSvcD, default value : "F"	"F", "H"		Phase 2
TSPX_MOChRateE	channel rate for TSPX_MOBscSvcE, default value : "F"	"F", "H"		Phase 2
TSPX_MOChRateF	channel rate for TSPX_MOBscSvcF, default value : "F"	"F", "H"		Phase 2
TSPX_MOChRateG	channel rate for TSPX_MOBscSvcG, default value : "F"	"F", "H"		Phase 2
TSPX_MOChRateH	channel rate for TSPX_MOBscSvcH, default value : "F"	"F", "H"		Phase 2
TSPX_MOChRateI	channel rate for TSPX_MOBscSvcI, default value : "F"	"F", "H"		Phase 2
TSPX_MOChRateJ	channel rate for TSPX_MOBscSvcJ, default value : "F"	"F", "H"		Phase 2

Item	Description	Type/Allowed values	Value chosen	Release
TSPX_MTChRateA	channel rate for TSPX_MTBscSvcA, default value : "F"	"F", "H"		Phase 2
TSPX_MTChRateB	channel rate for TSPX_MTBscSvcB, default value : "F"	"F", "H"		Phase 2
TSPX_MTChRateC	channel rate for TSPX_MTBscSvcC, default value : "F"	"F", "H"		Phase 2
TSPX_MTChRateD	channel rate for TSPX_MTBscSvcD, default value : "F"	"F", "H"		Phase 2
TSPX_MTChRateE	channel rate for TSPX_MTBscSvcE, default value : "F"	"F", "H"		Phase 2
TSPX_MTChRateF	channel rate for TSPX_MTBscSvcF, default value : "F"	"F", "H"		Phase 2
TSPX_MTChRateG	channel rate for TSPX_MTBscSvcG, default value : "F"	"F", "H"		Phase 2
TSPX_MTChRateH	channel rate for TSPX_MTBscSvcH, default value : "F"	"F", "H"		Phase 2
TSPX_MTChRateI	channel rate for TSPX_MTBscSvcI, default value : "F"	"F", "H"		Phase 2
TSPX_MTChRateJ	channel rate for TSPX_MTBscSvcJ, default value : "F"	"F", "H"		Phase 2
TSPX_MTNIC_ChRateA	channel rate for TSPX_MTNIC_BscSvcA, default value : "F"	"F", "H"		Phase 2
TSPX_MTNIC_ChRateB	channel rate for TSPX_MTNIC_BscSvcB, default value : "F"	"F", "H"		Phase 2
TSPX_MTNIC_ChRateC	channel rate for TSPX_MTNIC_BscSvcC, default value : "F"	"F", "H"		Phase 2
TSPX_MTNIC_ChRateD	channel rate for TSPX_MTNIC_BscSvcD, default value : "F"	"F", "H"		Phase 2
TSPX_MTNIC_ChRateE	channel rate for TSPX_MTNIC_BscSvcE, default value : "F"	"F", "H"		Phase 2
TSPX_MTNIC_ChRateF	channel rate for TSPX_MTNIC_BscSvcF, default value : "F"	"F", "H"		Phase 2
TSPX_MTNIC_ChRateG	channel rate for TSPX_MTNIC_BscSvcG, default value : "F"	"F", "H"		Phase 2
TSPX_MTNIC_ChRateH	channel rate for TSPX_MTNIC_BscSvcH, default value : "F"	"F", "H"		Phase 2

Item	Description	Type/Allowed values	Value chosen	Release
TSPX_MTNIC_ChRateI	channel rate for TSPX_MTNIC_BscSvcI, default value : "F"	"F", "H"		Phase 2
TSPX_MTNIC_ChRateJ	channel rate for TSPX_MTNIC_BscSvcJ, default value : "F"	"F", "H"		Phase 2
TSPX_EmgCallRate	Rate for the basic service supported for MO emergency calls	"F", "H"		Phase 2
TSPX_MO_NonCallSS	any supported MO non-call related supplementary service	"C_Telephony", "C_EmgCallSRV", "C_AltSpchG3", "C_AutoG3", "C_300cda", "C_1200cda", "C_120075cda", "C_2400cda", "C_4800cda", "C_2400cda", "C_4800cda", "C_PAD300", "C_PAD1200", "C_PAD120075", "C_PAD2400", "C_PAD4800", "C_PAD9600", "C_Pkt2400", "C_Pkt4800", "C_Pkt9600", "C_AltSpchData", "C_SpchData"		Phase 2
TSPX_MO_BscSvc_SMS	any supported MO SMS calls	"C_Telephony", "C_EmgCallSRV", "C_AltSpchG3", "C_AutoG3", "C_300cda", "C_1200cda", "C_120075cda", "C_2400cda", "C_4800cda", "C_2400cda", "C_4800cda", "C_PAD300", "C_PAD1200", "C_PAD120075", "C_PAD2400", "C_PAD4800", "C_PAD9600", "C_Pkt2400", "C_Pkt4800", "C_Pkt9600", "C_AltSpchData", "C_SpchData"		Phase 2

Item	Description	Type/Allowed values	Value chosen	Release
TSPX_MO_DualModSvc	any supported MO dual mode call	"C_Telephony", "C_EmgCallSRV", "C_AltSpchG3", "C_AutoG3", "C_300cda", "C_1200cda", "C_120075cda", "C_2400cda", "C_4800cda", "C_2400cda", "C_4800cda", "C_2400cda", "C_4800cda", "C_PAD300", "C_PAD1200", "C_PAD120075", "C_PAD2400", "C_PAD4800", "C_PAD9600", "C_Pkt2400", "C_Pkt4800", "C_Pkt9600", "C_AltSpchData", "C_SpchData"		Phase 2
TSPX_MO_DualModRate	Rate for the supported MO dual mode call in TSPX_MO_DualModSvc	"F", "H"		Phase 2
TSPX_Vcallref_Active1	VGCS/VBS call reference active	BITSTRING[27]	Group ID 1 on test SIM	R96
TSPX_Vcallref_Active2	VGCS/VBS call reference active	BITSTRING[27]	Group ID 4 on test SIM	R96
TSPX_Vcallref_Active3	VGCS/VBS call reference active	BITSTRING[27]	Group ID 20 on test SIM	R96
TSPX_Vcallref_Active4	VGCS/VBS call reference active	BITSTRING[27]	Group ID 30 on test SIM	R96
TSPX_Vcallref_Active5	VGCS/VBS call reference active	BITSTRING[27]	Group ID 50 on test SIM	R96
TSPX_Vcallref_NotActive	VGCS/VBS call reference non-active	BITSTRING[27]	Group ID 48 on test SIM	R96

Annex B (normative): PCTR Proforma

Notwithstanding the provisions of the copyright clause related to the text of the present document, ETSI grants that users of the present document may freely reproduce the PCTR proforma in this annex so that it can be used for its intended purposes and may further publish the completed PCTR.

PROTOCOL Conformance Test Report (PCTR)

Global System for Mobile Communication, GSM, User-Network Access

Layer 3 Signalling Functions

Test Candidate	
Name :	SUT name
Model :	model
H/W version :	hw
S/W version :	sw
Serial No. :	serienr

Client	
Name :	
Street / No. :	
Postal Code / City:	
Country :	

This Test Report shall not be reproduced except in full without the written permission of TEST LAB REFERENCE, and shall not be quoted out of context.

Annex C (normative): Layer 3 Abstract Test Suite

This ATS is a normative part of the present document. The graphic form (TTCN . GR) and machine processable (TTCN .MP) files of the ATS are referred to GSM 11.10-3, version 4.t.0

Annex D (normative): Enhanced Full Rate Abstract Test Suite

This ATS is a normative part of the present document. The graphic form (TTCN . GR) and machine processable (TTCN .MP) files of the ATS are referred to GSM 11.10-3, version 4.t.0.

Annex E (informative): Cell Selection Abstract Test Suite

This ATS is an informative part of the present document. The graphic form (TTCN .GR) and machine processable (TTCN .MP) files of the ATS are referred to GSM 11.10-3, version 4.t.0.

Annex F (informative): Dual band Abstract Test Suite

This ATS is an informative part of the present document. The graphic form (TTCN .GR) and machine processable (TTCN .MP) files of the ATS are referred to GSM 11.10-3, version 4.t.0.

Annex G (normative): RGSM Abstract Test Suite

This ATS has been produced using the Tree and Tabular Combined Notation (TTCN) according to ISO/IEC 9646-3 [3].

The ATS was developed on a separate TTCN software tool and therefore the TTCN tables are not completely referenced in the contents table. The ATS itself contains a test suite overview part which provides additional information and references.

G.1 The TTCN Graphical form (TTCN.GR)

The TTCN.GR representation of the ATS is contained in an Adobe Portable Document Format™ file (rgsm-500.PDF contained in archive en_30060703v090000o0.ZIP) which accompanies the present document (Part 3).

G.2 The TTCN Machine Processable form (TTCN.MP)

The TTCN.MP representation corresponding to the ATS for is contained in an ASCII file (rgsm-500.mp contained in archive en_30060703v090000o0.ZIP) which accompanies the present document (Part 3).

Annex H (normative): ASCI Abstract Test Suite

This ATS has been produced using the Tree and Tabular Combined Notation (TTCN) according to ISO/IEC 9646-3 [3].

The ATS contains groups for VGCS/VBS, eMLPP, UUS and Follow Me services. The ATS was developed on a separate TTCN software tool and therefore the TTCN tables are not completely referenced in the contents table. The ATS itself contains a test suite overview part which provides additional information and references.

These ATS are conform to R96 specifications

H.1 The TTCN Graphical form (TTCN.GR)

The TTCN.GR representation of the ATS is contained in an Adobe Portable Document Format™ file (ascii-900.PDF contained in archive en_30060703v090000o0.ZIP) which accompanies the present document (Part 3).

H.2 The TTCN Machine Processable form (TTCN.MP)

The TTCN.MP representation corresponding to the ATS for is contained in an ASCII file (ascii-900.mp, contained in archive en_30060703v090000o0.ZIP) which accompanies the present document (Part 3).

History

Document history		
V9.0.0	June 2000	