

# 3GPP TS 08.61 V8.1.0 (2002-02)

---

*Technical Specification*

**3rd Generation Partnership Project;  
Technical Specification Group GSM/EDGE Radio Access Network;  
Digital cellular telecommunications system (Phase 2+);  
In-band control of remote transcoders and rate adaptors  
for half rate traffic channels  
(Release 1999)**



The present document has been developed within the 3<sup>rd</sup> Generation Partnership Project (3GPP™) and may be further elaborated for the purposes of 3GPP.

The present document has not been subject to any approval process by the 3GPP Organizational Partners and shall not be implemented. This Specification is provided for future development work within 3GPP only. The Organizational Partners accept no liability for any use of this Specification. Specifications and reports for implementation of the 3GPP™ system should be obtained via the 3GPP Organizational Partners' Publications Offices.

---

Keywords

---

GSM, radio, adaption, codec

**3GPP**

Postal address

---

3GPP support office address

---

650 Route des Lucioles - Sophia Antipolis  
Valbonne - FRANCE  
Tel.: +33 4 92 94 42 00 Fax: +33 4 93 65 47 16

Internet

---

<http://www.3gpp.org>

---

**Copyright Notification**

---

No part may be reproduced except as authorized by written permission.  
The copyright and the foregoing restriction extend to reproduction in all media.

© 2002, 3GPP Organizational Partners (ARIB, CWTS, ETSI, T1, TTA, TTC).  
All rights reserved.

# Contents

Foreword .....	5
1 Scope .....	6
2 References.....	6
3 Definitions and abbreviations .....	7
3.1 Definitions.....	7
3.2 Abbreviations .....	7
4 General approach.....	8
5 Frame structure.....	10
5.1 16 kbit/s submultiplexing .....	10
5.1.1 Frames for Speech Services.....	10
5.1.1.1 Frame for Half Rate speech .....	10
5.1.1.2 Frames for Adaptive Multi-Rate Speech .....	10
5.1.2 Data frame .....	11
5.1.3 O&M frame .....	12
5.1.4 Coding .....	12
5.1.4.1 Coding of frames for speech services .....	13
5.1.4.1.1 Coding of frames for Half Rate speech Control bits (C-bits):.....	13
5.1.4.1.2 Coding of frames for Adaptive Multi-Rate speech .....	14
5.1.4.2 Coding of data frames.....	14
5.1.4.3 Coding of O&M frames .....	15
5.1.5 Order of Bit Transmission.....	15
5.2 8 kbit/s submultiplexing .....	15
5.2.1 Frames for Speech Services.....	15
5.2.1.1 Frame for Half Rate Speech .....	15
5.2.1.2 Frames for Adaptive Multi-Rate Speech .....	16
5.2.1.2.1 Frame for Lower Codec Modes.....	16
5.2.1.2.2 Speech frame for Codec Mode 6,70 kBit/s.....	16
5.2.1.2.3 Speech frame for Codec Mode 7,40 kBit/s.....	16
5.2.1.2.4 Speech frame for Codec Mode 7,95 kBit/s.....	17
5.2.2 Data frame .....	17
5.2.3 O&M frame .....	18
5.2.4 Coding .....	18
5.2.4.1 Coding for Half Rate Speech and Half Rate Data Services .....	18
5.2.4.1.1 Uplink coding .....	18
5.2.4.1.2 Downlink coding.....	20
5.2.4.2 Coding for Adaptive Multi-Rate Speech.....	21
5.2.4.2.1 No_Speech Frame .....	21
5.2.4.2.2 Speech Frames for 4,75, 5,15 and 5,90 kBit/s.....	22
5.2.4.2.3 Speech Frame for 6,70 kBit/s.....	23
5.2.4.2.4 Speech Frame for 7,40 kBit/s.....	24
5.2.4.2.5 Speech Frame for 7,95 kBit/s.....	24
5.2.5 Order of Bit Transmission.....	24
6 Procedures.....	24
6.1 Remote Control of Transcoders and Rate Adaptors .....	24
6.2 Resource Allocation .....	25
6.3 Resource Release .....	25
6.4 In Call Modification .....	25
6.5 Transfer of Idle Frames, Handling of missing data.....	26
6.6 Procedures for Speech Frames .....	26
6.6.1 Time Alignment of Speech Frames .....	26
6.6.1.1 16 kbit/s submultiplexing .....	26
6.6.1.1.1 Downlink Time Alignment.....	26
6.6.1.1.2 Uplink Time Alignment.....	29

6.6.1.1.3	Initiation at Resource Allocation .....	29
6.6.1.1.4	Time Alignment during Handover .....	29
6.6.1.2	8 kbit/s submultiplexing .....	29
6.6.1.2.1	Downlink Time Alignment.....	29
6.6.1.2.2	Uplink Time Alignment.....	31
6.6.1.2.3	Initiation at Resource allocation .....	32
6.6.1.2.4	Time Alignment during handover.....	32
6.6.2	Procedures for Discontinuous Transmission (DTX) .....	32
6.6.2.1	DTX procedures in the uplink direction .....	32
6.6.2.2	DTX procedures in the downlink direction.....	33
6.7	Procedures for Data Frames .....	33
6.7.1	The RAA Function.....	33
6.7.2	The RA1/RA1' Function.....	34
6.7.3	The RA2 Function.....	34
6.7.4	Procedures for 8 kbit/s intermediate rate adaption rate.....	34
6.7.5	Support of Non-Transparent Bearer Applications .....	35
6.8	Frame Synchronization .....	35
6.8.1	16 kbit/s submultiplexing .....	35
6.8.1.1	Search for Frame Synchronization .....	35
6.8.1.2	Frame Synchronization After Performing Downlink Timing Adjustments .....	35
6.8.1.3	Frame Synchronization Monitoring and Recovery .....	35
6.8.2	8 kbit/s submultiplexing .....	36
6.8.2.1	Search for Frame Synchronization .....	36
6.8.2.1.1	For Half Rate speech and data.....	36
6.8.2.1.2	For Adaptive Multi-Rate speech.....	36
6.8.2.2	Frame Synchronization Monitoring and Recovery .....	36
6.8.2.2.1	For Half Rate speech and data.....	36
6.8.2.2.2	For Adaptive Multi-Rate speech.....	37
6.9	Correction/detection of bit errors .....	37
6.9.1	16 kbit/s submultiplexing .....	37
6.9.1.1	Error Detection on the Control Bits .....	37
6.9.1.1.1	General Procedure.....	37
6.9.1.1.2	Frames for Half Rate speech.....	37
6.9.1.2	Handling of frames received with errors for Half Rate speech and data .....	38
6.9.2	8 kbit/s submultiplexing .....	38
6.9.2.1	Error Detection on the Control Bits .....	38
6.9.2.2	Handling of frames received with errors .....	38
6.10	Procedures for Operation & Maintenance.....	38
6.10.1	Transfer of O&M Information Between the TRAU and the BSC .....	39
6.10.2	Procedures in the TRAU .....	39
6.10.3	Procedures in the BSC.....	39
6.10.3.1	Use of O&M Frames .....	39
6.10.4	Procedures in the BTS .....	39
<b>Annex A (informative):</b>	<b>Change History.....</b>	<b>41</b>

---

# Foreword

This Technical Specification has been produced by the 3<sup>rd</sup> Generation Partnership Project (3GPP).

The contents of the present document are subject to continuing work within the TSG and may change following formal TSG approval. Should the TSG modify the contents of the present document, it will be re-released by the TSG with an identifying change of release date and an increase in version number as follows:

Version x.y.z

where:

- x the first digit:
  - 1 presented to TSG for information;
  - 2 presented to TSG for approval;
  - 3 or greater indicates TSG approved document under change control.
- y the second digit is incremented for all changes of substance, i.e. technical enhancements, corrections, updates, etc.
- z the third digit is incremented when editorial only changes have been incorporated in the document.

---

# 1 Scope

The present document describes the protocol between the Base Transceiver Station (BTS) and the remote Transcoder/Rate Adaption Unit (TRAU) for speech and data on half rate traffic channel (TCH/H).

For Half Rate speech and half rate data the protocol is specified for 8 kbit/s and 16 kbit/s submultiplexing scheme.

For Adaptive Multi-Rate speech the present document specifies the 8 kbit/s submultiplexing, both for the full and the half rate traffic channels (TCH/AFS and TCH/AHS). The specification for 16 kbit/s submultiplexing is given in Rec GSM 08.60, both for the full and the half rate traffic channels (TCH/AFS and TCH/AHS).

The present document should be considered together with the GSM 06 series, GSM 04.21 (Rate Adaption on the MS-BSS Interface) and GSM 08.20 (Rate Adaption on the BTS/MS interface).

---

# 2 References

The following documents contain provisions which, through reference in this text, constitute provisions of the present document.

- References are either specific (identified by date of publication, edition number, version number, etc.) or non-specific.
- For a specific reference, subsequent revisions do not apply.
- For a non-specific reference, the latest version applies. In the case of a reference to a 3GPP document (including a GSM document), a non-specific reference implicitly refers to the latest version of that document *in the same Release as the present document*.

- [1] GSM 01.02: "Digital cellular telecommunication system (Phase 2+); General description of a GSM Public Land Mobile Network (PLMN)".
- [2] GSM 01.04: "Digital cellular telecommunication system (Phase 2+); Abbreviations and acronyms".
- [3] GSM 04.21: "Digital cellular telecommunications system (Phase 2+); Rate adaption on the Mobile Station - Base Station System (MS - BSS) interface".
- [4] GSM 05.03: "Digital cellular telecommunications system (Phase 2+); Channel coding".
- [5] GSM 06.21: "Digital cellular telecommunications system (Phase 2+); Half rate speech; Substitution and muting of lost frames for half rate speech traffic channels".
- [6] GSM 06.22: "Digital cellular telecommunications system (Phase 2+); Half rate speech; Comfort noise aspects for half rate speech traffic channels".
- [7] GSM 06.41: "Digital cellular telecommunications system (Phase 2+); Half rate speech; Discontinuous Transmission (DTX) for half rate speech traffic channels".
- [8] GSM 06.42: "Digital cellular telecommunications system (Phase 2+); Half rate speech; Voice Activity Detector (VAD) for half rate speech traffic channels".
- [9] GSM 08.08: "Digital cellular telecommunication system (Phase 2+); Mobile Switching Centre - Base Station System (MSC - BSS) interface Layer 3 specification".
- [10] GSM 08.20: "Digital cellular telecommunication system (Phase 2+); Rate adaption on the Base Station System - Mobile-services Switching Centre (BSS - MSC) interface".
- [11] GSM 08.52: "Digital cellular telecommunication system (Phase 2+); Base Station Controller - Base Transceiver Station (BSC - BTS) interface Interface principles".
- [12] GSM 08.54: "Digital cellular telecommunication system (Phase 2+); Base Station Controller - Base Transceiver Station (BSC - BTS) interface Layer 1 structure of physical circuits".

- [13] GSM 08.58: "Digital cellular telecommunication system (Phase 2+); Base Station Controller - Base Transceiver Station (BSC - BTS) interface Layer 3 specification".
- [14] GSM 12.21: "Digital cellular telecommunication system (Phase 2); Network Management (NM) procedures and messages on the A-bis interface".
- [15] ITU-T Recommendation I.460: "Multiplexing, rate adaption and support of existing interfaces".
- [16] ITU-T Recommendation V.110: "Support of data terminal equipments (DTEs) with V-Series interfaces by an integrated services digital network".
- [24] GSM 06.71: "Digital cellular telecommunications system; Adaptive Multi-Rate speech processing functions, General Description."
- [25] GSM 06.90: "Digital cellular telecommunications system; Adaptive Multi-Rate speech transcoding".
- [26] GSM 06.91: "Digital cellular telecommunications system; Substitution and muting of lost frames for Adaptive Multi-Rate speech traffic channels".
- [27] GSM 06.92: "Digital cellular telecommunications system; Comfort noise aspect for Adaptive Multi-Rate speech traffic channels".
- [28] GSM 06.93: "Digital cellular telecommunications system; Discontinuous Transmission (DTX) for Adaptive Multi-Rate speech traffic channels".
- [29] GSM 06.94: "Digital cellular telecommunications system; Voice Activity Detection (VAD) for Adaptive Multi-Rate speech traffic channels".
- [30] GSM 05.09: "Digital cellular telecommunications system; Link Adaptation"
- [31] GSM 08.60: " Digital cellular telecommunications system; In-band control of remote transcoders and rate adaptors for full rate traffic channels".
- [32] GSM 08.62: " Digital cellular telecommunications system; Inband Tandem Free Operation (TFO) of Speech Codecs".

---

## 3 Definitions and abbreviations

### 3.1 Definitions

No specific definitions apply to the present document.

### 3.2 Abbreviations

For the purposes of the present document, the following abbreviations apply:

ACS	Active_Codec_Set
AMR	Adaptive Multi-Rate
BSC	Base Station Controller
BTS	Base Transceiver Station
CCU	Channel Codec Unit
CMC	Codec_Mode_Command
CMI	Codec_Mode_Indication
CMR	Codec_Mode_Request
DFE	Downlink Frame Error
ICM	Initial_Codec_Mode
PAB	Phase Alignment Bit
PAC	Phase Alignment Command
RA	Rate Adaption
RIF	Request or Indication Flag

TAC	Time Alignment Command
TAE	Time Alignment Extension
TFO	Tandem Free Operation
TFOE	TFO Enable
TRAU	Transcoder and Rate Adaption Unit
UFE	Uplink Frame Error

Other abbreviations used in the present document are listed in GSM 01.04.

---

## 4 General approach

The TRAU shall be controlled by the BTS when it is positioned remote from the BTS. In this case, the speech/data information and TRAU control signals exchanged between the Channel Codec Unit (CCU) in the BTS and the TRAU shall be transferred in frames denoted "TRAU frames".

The TRAU frames may be carried by either 16 kbit/s traffic channels or 8 kbit/s channels. The choice of the traffic channel bit rate or submultiplexing scheme is operator dependent.

The TRAU frames have a fixed length of:

- 160 bits (20 ms) when 8 kbit/s submultiplexing is used;
- 320 bits (20 ms) when 16 kbit/s submultiplexing is used.

The protocol between the BTS and the TRAU should be the same if the TRAU is positioned either at the MSC site or at the BSC site. In the first case, the BSC should be considered as transparent for 16 kbit/s and 8 kbit/s channels.

The TRAU is considered a part of the BSC when the TRAU is remote from the BTS (see GSM 08.52), and the signalling between the BSC and the TRAU (e.g. detection of call release, handover and transfer of O&M information) may be performed by using BSC internal signals. However, the signalling between the CCU and the TRAU, using TRAU frames as specified in the present document, is mandatory when the TRAU is remote from the BTS.

For data transfer, a conversion function is required, in addition to the conversion/rate adaption specified in GSM 08.20, to adapt ITU-T V.110 frames to the TRAU data frames. This function constitutes the RAA.

NOTE: If standard 64 kbit/s switching is used in the BSC, multiplexing according to ITU-T Recommendation I.460 should apply at both sides of the switch.

A possible configuration of the TRAU and the CCU is shown in figure 4.1.

The functions inside the TRAU are:

- "Remote Transcoder and Rate Adaptor Control Function" (RTRACF);
- "Remote Speech Handler Function" (RSHF);
- the RAA function;
- the RA2 function;
- the transcoder function.

The functions inside the CCU are:

- "Transcoder and Rate Adaptor Control Function" (TRACF);
- "Speech Handler Function" (SHF);
- the RAA function;
- the RA1/RA1' function;
- the channel codec function.



The present document does not describe the procedures inside the TRAU and the CCU. The layout in figure 4.1 is only intended as a reference model.

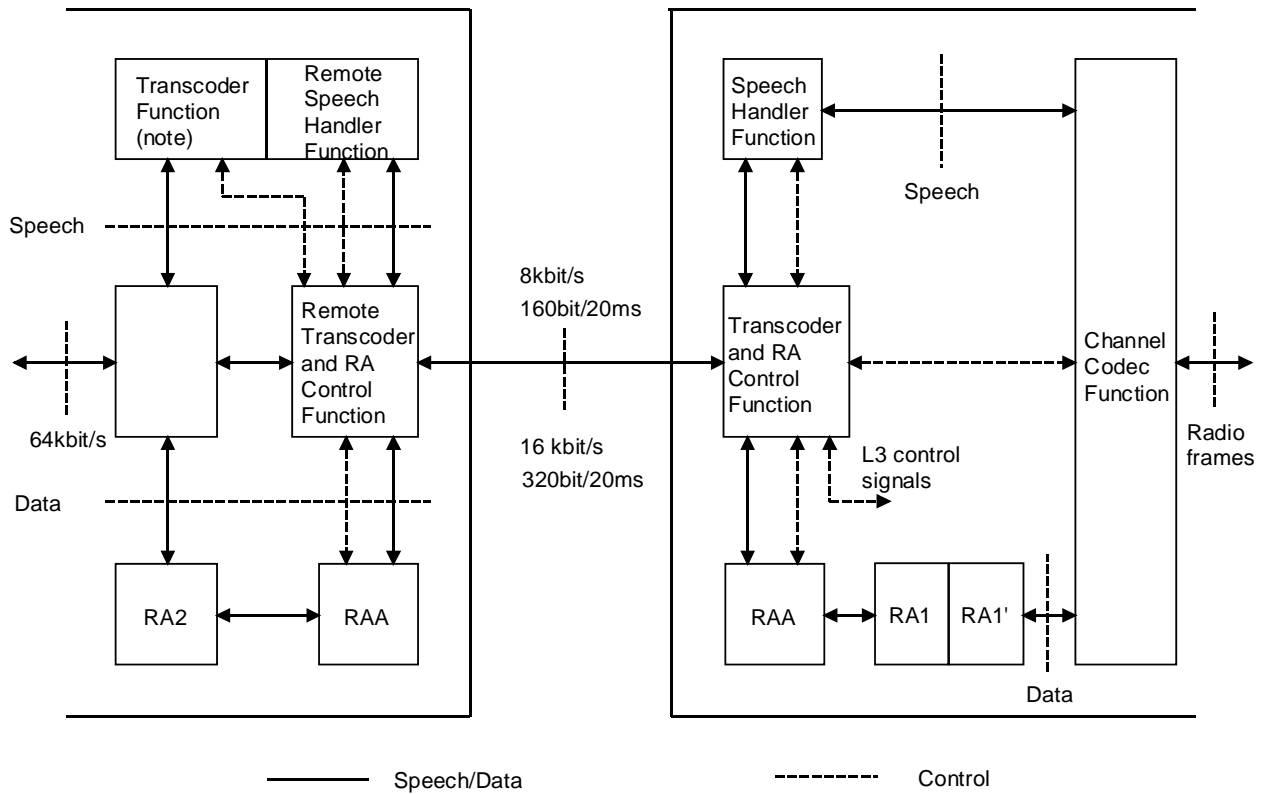

NOTE: This technical specification assumes the DTX handler function to be part of the Transcoder Function.

**Figure GSM 08.61/4.1: Functional entities for handling of control of remote transcoders and rate adaptors**

## 5 Frame structure

### 5.1 16 kbit/s submultiplexing

#### 5.1.1 Frames for Speech Services

##### 5.1.1.1 Frame for Half Rate speech

Octet no.	Bit number							
	1	2	3	4	5	6	7	8
1	0	0	0	0	0	0	0	0
2	0	0	0	0	0	0	0	0
3	1	C1	C2	C3	C4	C5	C6	C7
4	C8	C9	C10	C11	C12	C13	C14	C15
5	1	UFI	D1	D2	D3	D4	D5	D6
6	D7	D8	D9	D10	D11	D12	D13	D14
7	1	D15	D16	D17	D18	D19	D20	D21
8	D22	D23	D24	D25	D26	D27	D28	D29
9	1	D30	D31	D32	D33	D34	D35	D36
10	D37	D38	D39	D40	D41	D42	D43	D44
11	1	CRC2	CRC1	CRC0	D45	D46	D47	D48
12	D49	D50	D51	D52	D53	D54	D55	D56
13	1	D57	D58	D59	D60	D61	D62	D63
14	D64	D65	D66	D67	D68	D69	D70	D71
15	1	D72	D73	D74	D75	D76	D77	D78
16	D79	D80	D81	D82	D83	D84	D85	D86
17	1	D87	D88	D89	D90	D91	D92	D93
18	D94	D95	D96	D97	D98	D99	D100	D101
19	1	D102	D103	D104	D105	D106	D107	D108
20	D109	D110	D111	D112	1	1	1	1
21	1	1	1	1	1	1	1	1
22	1	1	1	1	1	1	1	1
23	1	1	1	1	1	1	1	1
24	1	1	1	1	1	1	1	1
25	1	1	1	1	1	1	1	1
26	1	1	1	1	1	1	1	1
27	1	1	1	1	1	1	1	1
28	1	1	1	1	1	1	1	1
29	1	1	1	1	1	1	1	1
30	1	1	1	1	1	1	1	1
31	1	1	1	1	1	1	1	1
32	1	1	1	1	1	1	1	1
33	1	1	1	1	1	1	1	1
34	1	1	1	1	1	1	1	1
35	1	1	1	1	1	1	1	1
36	1	1	1	1	1	1	1	1
37	1	1	1	1	1	1	1	1
38	1	1	1	1	1	1	1	1
39	1	1	1	1	1	1	C16	C17
40	C18	C19	C20	C21	T1	T2	T3	T4

##### 5.1.1.2 Frames for Adaptive Multi-Rate Speech

See GSM 08.60 for 16 kBit/s submultiplexing.

## 5.1.2 Data frame

Octet no.	Bit number							
	1	2	3	4	5	6	7	8
1	0	0	0	0	0	0	0	0
2	0	0	0	0	0	0	0	
3	1	C1	C2	C3	C4	C5	C6	C7
4	C8	C9	C10	C11	C12	C13	C14	C15
5	1	D1	D2	D3	D4	D5	D6	D7
6	1	D8	D9	D10	D11	D12	D13	D14
7	1	D15	D16	D17	D18	D19	D20	D21
8	1	D22	D23	D24	D25	D26	D27	D28
9	1	D29	D30	D31	D32	D33	D34	D35
10	1	D36	D37	D38	D39	D40	D41	D42
11	1	D43	D44	D45	D46	D47	D48	D49
12	1	D50	D51	D52	D53	D54	D55	D56
13	1	D57	D58	D59	D60	D61	D62	D63
14	1	1	1	1	1	1	1	1
15	1	1	1	1	1	1	1	1
16	1	1	1	1	1	1	1	1
17	1	1	1	1	1	1	1	1
18	1	1	1	1	1	1	1	1
19	1	1	1	1	1	1	1	1
20	1	1	1	1	1	1	1	1
21	1	1	1	1	1	1	1	1
22	1	1	1	1	1	1	1	1
23	1	D'1	D'2	D'3	D'4	D'5	D'6	D'7
24	1	D'8	D'9	D'10	D'11	D'12	D'13	D'14
25	1	D'15	D'16	D'17	D'18	D'19	D'20	D'21
26	1	D'22	D'23	D'24	D'25	D'26	D'27	D'28
27	1	D'29	D'30	D'31	D'32	D'33	D'34	D'35
28	1	D'36	D'37	D'38	D'39	D'40	D'41	D'42
29	1	D'43	D'44	D'45	D'46	D'47	D'48	D'49
30	1	D'50	D'51	D'52	D'53	D'54	D'55	D'56
31	1	D'57	D'58	D'59	D'60	D'61	D'62	D'63
32	1	1	1	1	1	1	1	1
33	1	1	1	1	1	1	1	1
34	1	1	1	1	1	1	1	1
35	1	1	1	1	1	1	1	1
36	1	1	1	1	1	1	1	1
37	1	1	1	1	1	1	1	1
38	1	1	1	1	1	1	1	1
39	1	1	1	1	1	1	1	1
40	1	1	1	1	1	1	1	1

Data frame  
position 1Data frame  
position 3

### 5.1.3 O&M frame

Octet no.	Bit number							
	1	2	3	4	5	6	7	8
1	0	0	0	0	0	0	0	0
2	0	0	0	0	0	0	0	0
3	1	C1	C2	C3	C4	C5	C6	C7
4	C8	C9	C10	C11	C12	C13	C14	C15
5	1	D1	D2	D3	D4	D5	D6	D7
6	D8	D9	D10	D11	D12	D13	D14	D15
7	1	D16	D17	D18	D19	D20	D21	D22
8	D23	D24	D25	D26	D27	D28	D29	D30
9	1	D31	D32	D33	D34	D35	D36	D37
10	D38	D39	D40	D41	D42	D43	D44	D45
11	1	D46	D47	D48	D49	D50	D51	D52
12	D53	D54	D55	D56	D57	D58	D59	D60
13	1	D61	D62	D63	D64	D65	D66	D67
14	D68	D69	D70	D71	D72	D73	D74	D75
15	1	D76	D77	D78	D79	D80	D81	D82
16	D83	D84	D85	D86	D87	D88	D89	D90
17	1	D91	D92	D93	D94	D95	D96	D97
18	D98	D99	D100	D101	D102	D103	D104	D105
19	1	D106	D107	D108	D109	D110	D111	D112
20	D113	D114	D115	D116	D117	D118	D119	D120
21	1	D121	D122	D123	D124	D125	D126	D127
22	D128	D129	D130	D131	D132	D133	D134	D135
23	1	D136	D137	D138	D139	D140	D141	D142
24	D143	D144	D145	D146	D147	D148	D149	D150
25	1	D151	D152	D153	D154	D155	D156	D157
26	D158	D159	D160	D161	D162	D163	D164	D165
27	1	D166	D167	D168	D169	D170	D171	D172
28	D173	D174	D175	D176	D177	D178	D179	D180
29	1	D181	D182	D183	D184	D185	D186	D187
30	D188	D189	D190	D191	D192	D193	D194	D195
31	1	D196	D197	D198	D199	D200	D201	D202
32	D203	D204	D205	D206	D207	D208	D209	D210
33	1	D211	D212	D213	D214	D215	D216	D217
34	D218	D219	D220	D221	D222	D223	D224	D225
35	1	D226	D227	D228	D229	D230	D231	D232
36	D233	D234	D235	D236	D237	D238	D239	D240
37	1	D241	D242	D243	D244	D245	D246	D247
38	D248	D249	D250	D251	D252	D253	D254	D255
39	1	D256	D257	D258	D259	D260	D261	D262
40	D263	D264	S1	S2	S3	S4	S5	S6

### 5.1.4 Coding

In the following clauses, the coding of the frames is described. Any spare or not used control bits should be coded binary "1".

### 5.1.4.1 Coding of frames for speech services

#### 5.1.4.1.1 Coding of frames for Half Rate speech Control bits (C-bits):

Description	Uplink	Downlink
Frame type (Bits C1 - C4)	C1 C2 C3 C4 0 0 0 1	C1 C2 C3 C4 1 1 1 0
Channel type Bit C5	1: half rate	1: half rate
Time Alignment (Bits C6 - C11)	Binary number indicating the required timing adjustment to be in steps of 250/500 $\mu$ s.  The following values apply for the coding C6C7 . . . C11 0 0 0 0 0 0 No change in frame timing 0 0 0 0 0 1 Delay frame 1 * 500 $\mu$ s 0 0 0 0 1 0 Delay frame 2 * 500 $\mu$ s ... .. ... .. 1 0 0 1 1 1 Delay frame 39 * 500 $\mu$ s 1 0 1 0 0 0 Not used ... .. 1 1 1 1 0 1 Not used 1 1 1 1 1 0 Delay frame 1 * 250 $\mu$ s 1 1 1 1 1 1 Advance frame 250 $\mu$ s	Binary number indicating the timing adjustment made.
Uplink Bad Frame Indicator (BFI) C12 (see GSM 06.41)  Downlink Uplink Frame Error (UFE) C12 (see clause 6.8.1.3)	0: BFI = 0 1: BFI = 1	0: UFE = 0: bad uplink framing 1: UFE = 1: good uplink framing
Silence Descriptor (SID) C13-C14 (see GSM 06.41)	C13 C14: SID SID1 SID0 0 0: SID = 0 0 1: SID = 1 1 0: SID = 2	
Time Alignment Flag (TAF) C15 (see GSM 06.41)	0: TAF = 0 1: TAF = 1	Spare
Speech indicator (SP) C16 (see GSM 06.41)	Spare	0: SP = 0 1: SP = 1
DTX downlink indicator (DTXd) C17	0: Downlink DTX shall not be applied 1: Downlink DTX shall be applied	Spare
Bits C18 - C21	Spare	Spare

UFI bit: Unreliable Frame Indication (see GSM 06.41).

This bit is set to binary "1" in the downlink direction.

#### Data Bits (D-bits)

Bits D1 .. D112: Speech block transferred in the same order as output from the transcoder (see GSM 06.20).

#### Cyclic Redundancy Check bits (CRC-bits)

Bits CRC0 .. CRC2: CRC of the bits D1 to D44.

The bits are coded according to a cyclic code using the generator polynomial:

$$g(X) = X^3 + X + 1$$

The encoding of the cyclic code is performed in a systematic form, which means that, in GF(2), the polynomial:

$$D1 * X^{46} + D2 * X^{45} + \dots + D44 * X^3 + CRC2 * X^2 + CRC1 * X + CRC0.$$

where CRC0, CRC1, CRC2 are the parity bits, when divided by  $g(X)$  yields a remainder equal to:

$$1 + X + X^2.$$

### Time Alignment Bits

Bits T1 .. T4: Bits positioned at the end of the downlink and uplink TRAU speech frames.

Downlink:

If the timing of the frame is to be advanced 250  $\mu$ s, these 4 bits are not transferred in order to reduce the frame length accordingly. When transferred, the bits are set to binary "1".

Uplink:

T1 and T2 are set to binary "1".

If the timing of the frame is to be advanced 125  $\mu$ s, the bits T3 and T4 are not transferred in order to reduce the frame length accordingly. When transferred, the bits are set to binary "1" (see clause 6.6.1.1.2).

#### 5.1.4.1.2 Coding of frames for Adaptive Multi-Rate speech

See GSM 08.60 for 16 kBit/s submultiplexing.

#### 5.1.4.2 Coding of data frames

Any spare or not used control bits should be coded binary "1".

#### Control bits (C-bits):

Description	Uplink	Downlink
Frame type Bits C1-C4	C1 C2 C3 C4 0 1 0 0: Data	C1 C2 C3 C4 1 0 1 1: Data
Channel type Bit C5	1: half rate	1: half rate
Intermediate RA bit rate Bit C6	0: 8 kbit/s	0: 8 kbit/s
Bits C7 - C11	Spare	Spare
Bit C12 Uplink Frame Error (UFE) C12 (see clause 6.8.1.3)	Spare	0: UFE = 0: bad uplink framing 1: UFE = 1: good uplink framing
Bits C13-C15	Spare	Spare

#### Idle data frame

An idle data frame is a data frame with all data bit positions set to binary "1" (i.e. all bits of the modified V.110 frames are set to "1").

### 5.1.4.3 Coding of O&M frames

#### Control bits (C-bits):

Description	Uplink	Downlink
Frame type Bits C1-C4	C1 C2 C3 C4 0 0 1 0: O&M	C1 C2 C3 C4 1 1 0 1: O&M
Channel type Bit C5	1: half rate	1: half rate
Bits C6 - C11	Spare	Spare
Bit C12 Uplink Frame Error (UFE) C12 (see clause 6.8.1.3)	Spare	0: UFE = 0: bad uplink framing 1: UFE = 1: good uplink framing
Bits C13-C15	Spare	Spare

#### Data Bits (D-bits)

Bits D1 .. D264: Bits used for transfer of O&M information. The coding and use of these bits are left to the manufacturer of the BSC/TRAU.

#### Spare Bits (S-bits)

Bits S1 .. S6: Spare.

### 5.1.5 Order of Bit Transmission

See GSM 08.60.

## 5.2 8 kbit/s submultiplexing

### 5.2.1 Frames for Speech Services

#### 5.2.1.1 Frame for Half Rate Speech

Octet no	Bit number							
	1	2	3	4	5	6	7	8
1	0	0	0	0	0	0	0	0
2	1	C1	C2	C3	C4	C5	XC1	XC2
3	0	1	XC3	XC4	XC5	XC6	D1	D2
4	1	D3	D4	D5	D6	D7	D8	D9
5	1	D10	D11	D12	D13	D14	D15	D16
6	1	D17	D18	D19	D20	D21	D22	D23
7	1	D24	D25	D26	D27	D28	D29	D30
8	1	D31	D32	D33	D34	D35	D36	D37
9	1	D38	D39	D40	D41	D42	D43	D44
10	1	CRC2	CRC1	CRC0	D45	D46	D47	D48
11	1	D49	D50	D51	D52	D53	D54	D55
12	1	D56	D57	D58	D59	D60	D61	D62
13	1	D63	D64	D65	D66	D67	D68	D69
14	1	D70	D71	D72	D73	D74	D75	D76
15	1	D77	D78	D79	D80	D81	D82	D83
16	1	D84	D85	D86	D87	D88	D89	D90
17	1	D91	D92	D93	D94	D95	D96	D97
18	1	D98	D99	D100	D101	D102	D103	D104
19	1	D105	D106	D107	D108	D109	D110	D111
20	1	D112	C6	C7	C8	C9	T1	T2

## 5.2.1.2 Frames for Adaptive Multi-Rate Speech

### 5.2.1.2.1 Frame for Lower Codec Modes

This frame layout shall be used for No\_Speech frames and speech frames for codec modes 4,75, 5,15 and 5,90 kBit/s.

Octet no	Bit number							
	1	2	3	4	5	6	7	8
1	0	0	0	0	0	0	0	0
2	1	D1	D2	D3	D4	D5	D6	D7
3	1	C1	C2	C3	C4	C5	D8	D9
4	0	1	D10	D11	D12	D13	D14	D15
5	1	D16	D17	D18	D19	D20	D21	D22
6	1							D29
7	1							D36
8	1							D43
9	1							D50
10	1							D57
11	1							D64
12	1							D71
13	1							D78
14	1							D85
15	1							D92
16	1							D99
17	1							D106
18	1							D113
19	1							D120
20	1	D121	D122	D123	D124	D125	D126	T

### 5.2.1.2.2 Speech frame for Codec Mode 6,70 kBit/s

This frame layout shall be used for speech frames for codec mode 6,70 kBit/s. The synchronisation pattern is unique and identifies this codec mode.

Octet no	Bit number							
	1	2	3	4	5	6	7	8
1	0	0	0	0	0	0	0	0
2	1	D1	D2	D3	D4	D5	D5	D7
3	1	C1	C2	C3	D8	D9	D10	D11
4	1	D12	D13	D14	D15	D16	D17	D18
5	1	D19	D	D	D	D	D	D25
6	0	D26	D	D	D	D	D	D32
7	1	D33	D	D	D	D	D	D39
8	D40	D	D	D	D	D	D	D47
9	1	D48	D	D	D	D	D	D54
10	D55	D	D	D	D	D	D	D62
11	1	D63	D	D	D	D	D	D69
12	D70	D	D	D	D	D	D	D77
13	1	D78	D	D	D	D	D	D84
14	D85	D	D	D	D	D	D	D92
15	1	D93	D	D	D	D	D	D99
16	D100	D	D	D	D	D	D	D107
17	1	D108	D	D	D	D	D	D114
18	D115	D	D	D	D	D	D	D122
19	1	D	D	D	D	D	D	D129
20	D130	D	D	D	D	D	D	D137

### 5.2.1.2.3 Speech frame for Codec Mode 7,40 kBit/s

This frame layout shall be used for speech frames for codec mode 7,40 kBit/s. The synchronisation pattern is unique and identifies this codec mode.



Octet no	Bit number							
	1	2	3	4	5	6	7	8
1	0	0	1	D1	D2	D3	D4	D5
2	0	D6	D7	D8	D9	D10	D11	D12
3	1	C1	C2	C3	D13	D14	D15	D16
4	0	D17	D18	D19	D20	D21	D22	D23
5	D24	D	D	D	D	D	D	D31
6	D32	D	D	D	D	D	D	D39
7	D40	D	D	D	D	D	D	D47
8	D48	D	D	D	D	D	D	D55
9	D56	D	D	D	D	D	D	D63
10	D64	D	D	D	D	D	D	D71
11	D72	D	D	D	D	D	D	D79
12	D80	D	D	D	D	D	D	D87
13	D88	D	D	D	D	D	D	D95
14	D96	D	D	D	D	D	D	D103
15	D104	D	D	D	D	D	D	D111
16	D112	D	D	D	D	D	D	D119
17	D120	D	D	D	D	D	D	D127
18	D128	D	D	D	D	D	D	D135
19	D136	D	D	D	D	D	D	D143
20	D144	D145	D146	D147	D148	D149	D150	D151

5.2.1.2.4 Speech frame for Codec Mode 7,95 kBit/s

AMR Codec Mode 7,95 kBit/s is not supported in 8 kBit/s submultiplexing.

5.2.2 Data frame

Octet no.	Bit number								
	1	2	3	4	5	6	7	8	
1	0	0	0	0	0	0	0	0	
2	1	C1	C2	C3	C4	C5	D1	D2	
3	0	1	D3	D4	D5	D6	D7	D8	
4	1	D9	D10	D11	D12	D13	D14	D15	
5	1	D16	D17	D18	D19	D20	D21	D22	Data frame
6	1	D23	D24	D25	D26	D27	D28	D29	position 1
7	1	D30	D31	D32	D33	D34	D35	D36	
8	1	D37	D38	D39	D40	D41	D42	D43	
9	1	D44	D45	D46	D47	D48	D49	D50	
10	1	D51	D52	D53	D54	D55	D56	D57	
11	1	D58	D59	D60	D61	D62	D63	D'1	
12	1	D'2	D'3	D'4	D'5	D'6	D'7	D'8	
13	1	D'9	D'10	D'11	D'12	D'13	D'14	D'15	
14	1	D'16	D'17	D'18	D'19	D'20	D'21	D'22	
15	1	D'23	D'24	D'25	D'26	D'27	D'28	D'29	Data frame
16	1	D'30	D'31	D'32	D'33	D'34	D'35	D'36	position 2
17	1	D'37	D'38	D'39	D'40	D'41	D'42	D'43	
18	1	D'44	D'45	D'46	D'47	D'48	D'49	D'50	
19	1	D'51	D'52	D'53	D'54	D'55	D'56	D'57	
20	1	D'58	D'59	D'60	D'61	D'62	D'63	1	

### 5.2.3 O&M frame

Octet no.	Bit number							
	1	2	3	4	5	6	7	8
1	0	0	0	0	0	0	0	0
2	1	C1	C2	C3	C4	C5	XC1	XC2
3	0	1	XC3	XC4	XC5	XC6	D1	D2
4	1	D3	D4	D5	D6	D7	D8	D9
5	1	D10	D11	D12	D13	D14	D15	D16
6	1	D17	D18	D19	D20	D21	D22	D23
7	1	D24	D25	D26	D27	D28	D29	D30
8	1	D31	D32	D33	D34	D35	D36	D37
9	1	D38	D39	D40	D41	D42	D43	D44
10	1	D45	D46	D47	D48	D49	D50	D51
11	1	D52	D53	D54	D55	D56	D57	D58
12	1	D59	D60	D61	D62	D63	D64	D65
13	1	D66	D67	D68	D69	D70	D71	D72
14	1	D73	D74	D75	D76	D77	D78	D79
15	1	D80	D81	D82	D83	D84	D85	D86
16	1	D87	D88	D89	D90	D91	D92	D93
17	1	D94	D95	D96	D97	D98	D99	D100
18	1	D101	D102	D103	D104	D105	D106	D107
19	1	D108	D109	D110	D111	D112	D113	D114
20	1	D115	D116	D117	D118	D119	D120	1

### 5.2.4 Coding

#### 5.2.4.1 Coding for Half Rate Speech and Half Rate Data Services

In the following clauses, the coding of the frames is described for all services, except for Adaptive Multi-Rate Speech (AMR). Any spare or not used transmitted control bits should be coded binary "1".

##### 5.2.4.1.1 Uplink coding

###### Control bits (C-bits, for all frame types)

The control bits are coded according to the following table:

C1	C2	C3	C4	C5	Meaning
0	0	0	1	OP	Speech frame
0	0	1	1	OP	Data frame
0	1	0	1	OP	O&M frame

All other codings are reserved.

OP: odd parity of bits C1 to C4.

In the following, the term "frame type" refers to the control bits C1 to C3.

C6	C7	C8	C9	Meaning
TA2	TA1	TA0	DTXd	For speech frame only

DTXd: DTX downlink indicator.

0: Downlink DTX shall not be applied.

1: Downlink DTX shall be applied.

TA2-TA0: Time Alignment Command, see clause 6.6.1.2.1.

**Extended control bits**

The extended control bits are coded according to the following table:

Frames for Half Rate Speech

XC1	XC2	XC3	XC4	XC5	XC6	Meaning
0	0	0	0	0	OP	Good speech frame with UFI = 0 (BFI=0, SID=0, TAF=1) (BFI=0, SID=0, TAF=0)
0	0	0	0	1	OP	Unreliable speech frame (if speech decoder is in speech decoding mode) or unusable frame (if speech decoder is in comfort noise insertion mode) with UFI = 1 (BFI=0, SID=0, TAF=1) (BFI=0, SID=0, TAF=0)
0	0	0	1	0	OP	Valid SID frame with UFI = 0 (BFI=0, SID=2, TAF=1) (BFI=0, SID=2, TAF=0)
0	0	0	1	1	OP	Invalid SID frame with UFI = 1 (BFI=0, SID=2, TAF=1) (BFI=0, SID=2, TAF=0)
0	1	0	0	0	OP	Invalid SID frame at TAF=0 with UFI = 0 (BFI=0, SID=1, TAF=0) (BFI=1, SID=1, TAF=0) (BFI=1, SID=2, TAF=0)
0	1	0	0	1	OP	Invalid SID frame at TAF=0 with UFI = 1 (BFI=0, SID=1, TAF=0) (BFI=1, SID=1, TAF=0) (BFI=1, SID=2, TAF=0)
0	1	0	1	0	OP	Invalid SID frame at TAF=1 with UFI = 0 (BFI=0, SID=1, TAF=1) (BFI=1, SID=1, TAF=1) (BFI=1, SID=2, TAF=1)
0	1	0	1	1	OP	Invalid SID frame at TAF=1 with UFI = 1 (BFI=0, SID=1, TAF=1) (BFI=1, SID=1, TAF=1) (BFI=1, SID=2, TAF=1)
0	1	1	0	0	OP	Bad speech frame or unusable frame at TAF = 0 with UFI = 0 (BFI=1, SID=0, TAF=0)
0	1	1	0	1	OP	Bad speech frame or unusable frame at TAF = 0 with UFI = 1 (BFI=1, SID=0, TAF=0)
0	1	1	1	0	OP	Bad speech frame or unusable frame at TAF = 1 with UFI = 0 (BFI=1, SID=0, TAF=1)
0	1	1	1	1	OP	Bad speech frame or unusable frame at TAF = 1 with UFI = 1 (BFI=1, SID=0, TAF=1)

O&M frame

XC1	XC2	XC3	XC4	XC5	XC6	Meaning
1	1	1	1	1	OP	O&M frame

All other codings are reserved.

OP: odd parity of bits XC1 to XC5.

BFI, SID, TAF: see description in clause 5.1.4.1.

UFI bit: Unreliable Frame Indication (see GSM 06.41).

**Cyclic Redundancy Check bits (CRC-bits)**

Half Rate Speech frame: Bits CRC0 .. CRC2: CRC of the bits D1 to D44. Same coding as in clause 5.1.4.1.

**Data bits (D-bits)**

Speech frame: Bits D1 .. D112:

For good speech frame: speech block transferred in the same order as output from the transcoder (see GSM 06.20).

For valid SID frame: SID data block transferred in the same order as output from the transcoder (see GSM 06.22).

Data frame: Bits D1 .. D63 for data frame position 1 and bits D'1 .. D'63 for data frame position 2 (see clause 6.7.1).

O&M frame: Bits D1 .. D120: Bits used for transfer of O&M information. The coding and use of these bits are left to the manufacturer of the BSC/TRAU.

**Time Alignment bits (T-bits)**

Bits T1..T2: Bits positioned at the end of the uplink TRAU speech frame.

T1 is set to binary "1".

If the timing of the frame is to be advanced 125  $\mu$ s, the bit T2 is not transferred in order to reduce the frame length accordingly. When transferred, the bit T2 is set to binary "1".

## 5.2.4.1.2 Downlink coding

**Control bits**

C1	C2	C3	C4	C5	Meaning
0	0	0	UFE	OP	Speech frame
0	0	1	UFE	OP	Data frame
0	1	0	UFE	OP	O&M frame

All other codings are reserved.

UFE: Uplink Frame Error.  
 UFE = 0: bad uplink framing.  
 UFE = 1: good uplink framing.  
 See clause 6.8.2.2.

OP: Odd parity of bits C1 to C4.

In the following, the term "frame type" refers to the control bits C1 to C3.

C6	C7	C8	C9	Meaning
1	1	1	1	Spare bits

**Extended control bits**

The extended control bits are coded according to the following table:

Frames for Half Rate speech

XC1	XC2	XC3	XC4	XC5	XC6	Meaning
0	0	0	0	0	OP	Good speech frame (SP = 1)
0	0	0	1	0	OP	Valid SID frame (SP = 0)

SP:Speech indicator (see GSM 06.41).

O&M frame

XC1	XC2	XC3	XC4	XC5	XC6	Meaning
1	1	1	1	1	OP	O&M

All other codings are reserved.

XC6: odd parity of bits XC1 to XC5.

#### Data bits (D-bits)

Same as the uplink.

#### Time Alignment bits (T-bits)

Bits T1..T2: Bits positioned at the end of the downlink TRAU speech frame.

If the timing of the frame is to be advanced 250  $\mu$ s, the bits T1 and T2 are not transferred in order to reduce the frame length accordingly. When transferred, the bits are set to binary "1" (see clause 6.6.1.2.1).

#### Cyclic Redundancy Check bits (CRC-bits):

Same as the uplink.

### 5.2.4.2 Coding for Adaptive Multi-Rate Speech

Coding in uplink and downlink direction is identical. The synchronisation patterns for the Adaptive Multi Rate speech differ from the ones used for the other services. An explicit Frame\_Type is not defined for AMR, instead the synchronisation patterns itself identify the service (Frame\_Type) and to some extent the Codec\_Mode.

The CRC-bits inserted are calculated as described in clause 5.1.4.1. The control elements are as defined in GSM 08.60 (RIF, CMI, CMR, TAC, TAE, PAB, ...). The coding is, however, sometimes different.

#### 5.2.4.2.1 No\_Speech Frame

The frame layout for lower modes shall be used.

##### Control Information (C-Bits):

C1 . C2 . C3: set to "1.0.0", if RIF equals "0" (frame with Codec\_Mode Indication phase)

set to "1.0.1", if RIF equals "1" (frame with Codec\_Mode Request phase)

C4 . C5: set to "0.0", this is the Frame\_Classification for No\_Speech Frames.

##### Coding of D-Bits:

The D-Bits in No\_Speech frames carry additional control information:

D1 .. D6: Time Alignment Field (as defined in GSM 08.60)  
 D7: In DL: Uplink Frame Error (UFE), in UL: Downlink Frame Error (DFE)  
 D8 .. D10: No\_Speech\_Classification (as defined in GSM 08.60)  
 D11 .. D13: CMI\_abs (as defined in GSM 08.60)  
 D14 .. D16: CMR\_abs (as defined in GSM 08.60)

The Uplink Frame Error (UFE) is coded and defined as in GSM 08.60.

The Downlink Frame Error (DFE) is - different to 08.60 - defined in uplink direction to allow fast recovery from synchronisation loss in higher codec modes. The coding is like for UFE.

The procedure is described in clause 6.9.2.

The coding for D55...D59 is common to all three lower code modes. These bits are reserved for the Configuration Protocol (Config\_Prot and Message\_No) in case of Tandem Free Operation, see GSM 08.62. If the BTS does not support TFO or TFO is disabled, then these bits shall be set to "0.0.0.0.0".

D55 .. D57: Config\_Prot  
 D58 .. D59: Message\_No

Time Alignment Extension and Phase Alignment:

D60: Phase Alignment Bit (PAB) (as defined in GSM 08.60)  
 D61 .. D62: Time Alignment Extension (TAE) (as defined in GSM 08.60)

DTX and TFO control:

D63: DTX in downlink requested (DTXd) (as defined in GSM 08.60)  
 D64: TFO Enabled (TFOE) (as defined in GSM 08.60)

The bits D65...D125 (61 bits) are reserved for Tandem Free Operation (see GSM 08.62). If the BTS does not support TFO or TFO is disabled, then these bits shall be set to all "1".

The bits D17...D54 (38 bits) are also reserved for Tandem Free Operation (see GSM 08.62), if not needed otherwise, i.e. in all No\_Speech frames classified neither as SID\_Update nor as SID\_Bad. If the BTS does not support TFO or TFO is disabled, then these bits shall be set to all "1" in these cases.

In case the frames are classified as SID\_Update or SID\_Bad the bits D17...D54 code the Silence Description parameters (as defined in GSM 06.90):

Silence Description parameters (as defined in GSM 06.90):

D17 .. D19: Moving average predictor, initial values (s1...s3)  
 D20 .. D45: Indexes of LSF submatrices (s4...s29)  
 D46 .. D51: Logarithmic frame energy (s30...s35)  
 D52 .. D54: CRC1 over bits C1...C5, D1...D51.

Time Alignment Bits:

D126 .. T: Coding as defined for Half Rate speech (T1 .. T2).

### 5.2.4.2.2 Speech Frames for 4,75, 5,15 and 5,90 kBit/s

The frame layout for lower modes shall be used. Speech Frames for 4,75, 5,15 and 5,90 kBit/s are defined, if Frame Classification is not set to "0.0", otherwise the frame is a No\_Speech Frame (see above).

Coding of Control Information (C-Bits):

The coding for C1 to C5 is common in all three Codec\_Modes. Codec Mode Indication (CMI) plus Codec Mode Request (CMR) plus Request or Indication Flag (RIF) are coded with one 3-bit field. These three control elements are as defined in GSM 08.60. The coding is somewhat different:

C1.C2.C3:

0 . 0 . 0: CMI = 4,75; CMR = ?; RIF = 0.  
 0 . 0 . 1: CMI = 5,15; CMR = ?; RIF = 0.  
 0 . 1 . 0: CMI = 5,90; CMR = ?; RIF = 0.  
 0 . 1 . 1: CMI = ?; CMR = 4,75; RIF = 1.  
 1 . 0 . 0: CMI = ?; CMR = 5,15; RIF = 1.  
 1 . 0 . 1: CMI = ?; CMR = 5,90; RIF = 1.  
 1 . 1 . 0: CMI = ?; CMR = 6,70; RIF = 1.  
 1 . 1 . 1: CMI = ?; CMR = 7,40; RIF = 1.

Frame Classification (C4...C5) is defined and coded as in GSM 08.60.

Coding of D-Bits:

The coding for D55...D59 is common to all three lower code modes. These bits are reserved for the Configuration Protocol (Config\_Prot and Message\_No) in case of Tandem Free Operation, see GSM 08.62. If the BTS does not support TFO or TFO is disabled, then these bits shall be set to "0.0.0.0.0".

AMR Mode 4,75 kBit/s, see GSM 06.90:

D1 .. D3: spare (3 bits), set to "1"  
 D4 .. D26: Indexes of the LSF submatrices (s1...s23)  
 D27 .. D51: Indexes of the parameters of first sub-frame (s24...s48)  
 D52 .. D54: CRC1 over bits C1...C5, s1...s16, s18, s19, s21...s29, s45...s48.

D55 .. D59: reserved for TFO  
 D60 .. D72: Indexes of the parameters of second sub-frame (s49...s61)  
 D73 .. D75: CRC2 over bits D55...D59, s49, s50.  
 D76 .. D96: Indexes of the parameters of third sub-frame (s62...s82)  
 D97 .. D99: CRC3 over bits s62, s63, s79...s82.  
 D100 .. D112: Indexes of the parameters of fourth sub-frame (s83...s95)  
 D113 .. D115: CRC4 over bits s83, s84.  
 D116 .. D126: spare (11 bits); set to "1".

AMR Mode 5,15 kBit/s, see GSM 06.90:

D1 .. D5: spare (5 bits); set to "1"  
 D6...D28: Indexes of the LSF submatrices (s1...s23)  
 D29...D51: Indexes of the parameters of first sub-frame (s24...s46)  
 D52 .. D54: CRC1 over bits C1...C5, s1...s16, s19...s29, s42...s46.  
 D55 .. D59: reserved for TFO  
 D60 .. D78: Indexes of the parameters of second sub-frame (s47...s65)  
 D79 .. D81: CRC2 over bits D55...D59, s47, s48, s61...s65.  
 D82 .. D100: Indexes of the parameters of third sub-frame (s66...s84)  
 D101 .. D103: CRC3 over bits s66, s67, s80...s84.  
 D104 .. D122: Indexes of the parameters of fourth sub-frame (s85...s103)  
 D123 .. D125: CRC4 over bits s85, s86, s99...s103.  
 D126: spare (1 bits); set to "1".

AMR Mode 5,90 kBit/s, see GSM 06.90:

D1 .. D26: Indexes of the LSF submatrices (s1...s26)  
 D27 .. D51: Indexes of the parameters of first sub-frame (s27...s51)  
 D52 .. D54: CRC1 over bits C1...C5, s1...s17, s27...s34, s48...s51.  
 D55 .. D59: reserved for TFO  
 D60 .. D80: Indexes of the parameters of second sub-frame (s52...s72)  
 D81 .. D105: Indexes of the parameters of third sub-frame (s73...s97)  
 D106 .. D126: Indexes of the parameters of fourth sub-frame (s98...s118).

Time Alignment Bit:

T: Set to "1". May be omitted, then the next frame is advanced by 125  $\mu$ s.

### 5.2.4.2.3 Speech Frame for 6,70 kBit/s

The frame layout for codec mode 6,70 shall be used. By this the Codec Mode Indication is defined to be 6,70 kBit/s, regardless of the phase of the RIF bit.

Coding of Control Information (C-Bits):

Codec Mode Request (CMR) plus Request or Indication Flag (RIF) plus Frame Classification (FC) are coded with one 3-bit field. These three control elements, are as defined in GSM 08.60. The coding is somewhat different:

C1.C2.C3:

0 . 0 . 0: CMR = ?; RIF = 0; FC = "Speech\_Bad".  
 0 . 0 . 1: CMR = ?; RIF = 0; FC = "Speech\_Good".  
 0 . 1 . 0: CMR = (D1...D3); RIF = 1 FC = "Speech\_Bad".  
 0 . 1 . 1: CMR = 4,75; RIF = 1; FC = "Speech\_Good".  
 1 . 0 . 0: CMR = 5,15; RIF = 1; FC = "Speech\_Good".  
 1 . 0 . 1: CMR = 5,90; RIF = 1; FC = "Speech\_Good".  
 1 . 1 . 0: CMR = 6,70; RIF = 1; FC = "Speech\_Good".  
 1 . 1 . 1: CMR = 7,40; RIF = 1; FC = "Speech\_Good".

"CMR = (D1...D3)" indicates that the CMR is defined in this specific case of "Speech\_Bad" within the D-Bits, which would be otherwise undefined. The coding of CMR in this case is:

D1.D2.D3:

0 . 0 . 0: undefined, reserved  
 0 . 0 . 1: undefined, reserved  
 0 . 1 . 0: undefined, reserved  
 0 . 1 . 1: CMR = 4,75.  
 1 . 0 . 0: CMR = 5,15.  
 1 . 0 . 1: CMR = 5,90.

- 1.1.0: CMR = 6,70.  
 1.1.1: CMR = 7,40.

Coding of D-Bits, see GSM 06.90:

- D1 .. D26: Indexes of the LSF submatrices (s1...s26)  
 D27 .. D55: Indexes of the parameters of first sub-frame (s27...s55)  
 D56 .. D58: CRC1 over bits C1...C3, D1...D3, s4...s17, s20, s24, s27...s34, s49...s53.  
 D59 .. D83: Indexes of the parameters of second sub-frame (s56...s80)  
 D84 .. D112: Indexes of the parameters of third sub-frame (s81...s109)  
 D113 .. D137: Indexes of the parameters of fourth sub-frame (s110...s134).

#### 5.2.4.2.4 Speech Frame for 7,40 kBit/s

The frame layout for codec mode 7,40 shall be used. By this the Codec Mode Indication is defined to be 7,40 kBit/s, regardless of the phase of the RIF bit.

Coding of Control Information (C-Bits):

Codec Mode Request (CMR) plus Request or Indication Flag (RIF) plus Frame Classification (FC) are coded with one 3-bit field. These three control elements are as defined in GSM 08.60.

The coding is exactly as described for codec mode 6,70, except that the CMR in case of "Speech\_Bad" is defined in bits D6...D8 (instead of D1...D3) and thus at exactly the same position within the frame.

Coding of D-Bits, see GSM 06.90:

- D1 .. D26: Indexes of the LSF submatrices (s1...s26)  
 D27 .. D58: Indexes of the parameters of first sub-frame (s27...s58)  
 D59 .. D61: CRC1 over bits C1 to C3, D1... D20, s22...s24, s27...s32, s52, s53, s55...s57.  
 D62 .. D90: Indexes of the parameters of second sub-frame (s59...s87)  
 D91 .. D122: Indexes of the parameters of third sub-frame (s88...s119)  
 D123 .. D151: Indexes of the parameters of fourth sub-frame (s120...s148).

#### 5.2.4.2.5 Speech Frame for 7,95 kBit/s

Codec mode 7,95 kBit/s is not supported in 8 kBit/s submultiplexing.

### 5.2.5 Order of Bit Transmission

The order of bit transmission is:

Bit m of octet n shall be transmitted as bit  $((n-1)*8+m)$  with  $m=(1..8)$  and  $n=(1..20)$ .

## 6 Procedures

For AMR speech on 8 kBit/s submultiplexing the procedures are very much identical to the ones described in GSM 08.60 for AMR speech on 16 kBit/s submultiplexing. In the present recommendation (08.61) therefore only the procedures are defined that differ from that.

### 6.1 Remote Control of Transcoders and Rate Adaptors

When the TRAU is positioned remote from the BTS, the CCU in the BTS has to control some of the functions in the remote TRAU.

This remote control is performed by in-band signalling carried by the control bits in each TRAU frame.

The following functions in the TRAU are remotely controlled by the CCU:

- change between speech and data;
- downlink frame timing for speech frames;



- transfer of DTX information.

In addition the following is transferred in case of AMR speech:

- control of Codec Mode Adaptation;
- transfer of TFO Configuration Parameters (optional, see GSM 08.62);
- downlink Phase Alignment (optional, see GSM 08.60);
- transfer of Information on TFO and Handover Status (optional, see GSM 08.60 and 08.62).

In addition, the in-band signalling also provides means for transfer of O&M signals between the TRAU and the BSC/BTS.

## 6.2 Resource Allocation

In case of AMR speech see GSM 08.60.

At reception of the GSM 08.08 ASSIGNMENT REQUEST message, e.g. at call setup, when a circuit switched connection is required, the BSC provides an appropriate TRAU to the circuit to be used between the BSC and the BTS and sends the GSM 08.58 CHANNEL ACTIVATION message to the BTS.

When receiving the CHANNEL ACTIVATION message, the BTS allocates the appropriate radio resources and a CCU to be used.

The CCU now starts sending uplink TRAU frames with the appropriate frame type.

When receiving the first frame, the TRAU sets the mode of operation as indicated by the CCU and starts sending downlink TRAU frames with the corresponding frame type.

## 6.3 Resource Release

In case of AMR speech see GSM 08.60.

At release of circuit switched resources, e.g. at call release, the connection between the CCU and the TRAU will be released by the BSC. The BSC has to indicate that the connection has been released. How this is performed is a BSC internal matter. Two methods may be used for either submultiplexing scheme.

- The BSC indicates the call release to the TRAU by inserting the PCM idle bit pattern described in GSM 08.54 on the circuits towards the TRAU. The TRAU shall be able to detect this idle bit pattern. When received at the TRAU, the TRAU will lose frame synchronization and will start timer  $T_{\text{release}} = 1$  second. If, when  $T_{\text{release}}$  expires, the idle bit pattern is detected, the TRAU shall terminate the operation (go idle) until a valid frame is again received.  $T_{\text{release}}$  is reset every time the frame synchronization is again obtained.
- It is handled by BSC internal signals (e.g. if the BSC and TRAU are collocated).

## 6.4 In Call Modification

In case of AMR speech see GSM 08.60.

At reception of the GSM 08.58 MODE MODIFY message from the BSC indicating a change between speech and data, the BTS orders the corresponding CCU to modify its mode of operation. The CCU sets the frame type in the uplink TRAU frames to the new mode of operation.

When the TRAU receives an uplink TRAU frame with the frame type, different from the current mode but without errors detected (see clause 6.9.1.2), the current mode is kept and speech/data bits are handled as erroneous. When receiving the next TRAU frame with the same frame type, the TRAU changes the mode of operation accordingly and sets the new frame type in the downlink frames.

## 6.5 Transfer of Idle Frames, Handling of missing data

In case of AMR speech see GSM 08.60.

If no speech is received from the MS (uplink direction) in case of Half Rate speech, the CCU shall send TRAU speech frames with BFI flag set to 1 (bad frame). If no data is received from the MS (uplink direction), the CCU shall send idle TRAU data frames.

For Half Rate speech calls, the CCU shall transmit a speech frame with the three parity bits inverted (protection of the most significant 22 class 1 bits, see GSM 05.03) on the air interface:

- if frame synchronization has been lost in the downlink direction;
- if a CRC error is detected (bits CRC0-CRC2) in a downlink TRAU speech frame;
- if an O&M TRAU frame is received (see clause 6.10).

For data calls, the CCU shall react towards the air interface as if an idle TRAU data frame has been received:

- when frame synchronization has been lost in the downlink direction;
- when an O&M TRAU frame is received (see clause 6.10).

An idle TRAU data frame is a TRAU data frame with all data bits set to binary "1".

## 6.6 Procedures for Speech Frames

### 6.6.1 Time Alignment of Speech Frames

The time alignment needed for obtaining minimum buffer delay will differ from call to call. The reasons for this are:

- the BSC will have no information about the radio timing at the BTS, and will start sending TRAU frames at an arbitrary or default time. In the case of 16 kbit/s submultiplexing, each TRAU frame is 320 bits (20 ms) and will in the worst case be received at the BTS 318 bits out of phase. In the case of 8 kbit/s submultiplexing, each TRAU frame is 160 bits (20 ms) and will in the worst case be received at the BTS 159 bits out of phase;
- the different timeslots and half rate subchannels on one carrier are sent at different times (max. 8.66 ms which equals 15 radio time slots);
- different channels may be transferred on different transmission systems using different routes in the network. The transmission delay may therefore differ.

The required time alignment procedure between radio frames and TRAU frames is specified in clauses 6.6.1.1 and 6.6.1.2 for the 16 kbit/s submultiplexing and the 8 kbit/s submultiplexing respectively.

In order to achieve optimum timing between the radio TDMA frames and the frames on the transmission side, the speech coding and decoding function in the transcoder should not be synchronized.

#### 6.6.1.1 16 kbit/s submultiplexing

For AMR speech see GSM 08.60.

##### 6.6.1.1.1 Downlink Time Alignment

###### 6.6.1.1.1.1 Initial Time Alignment state

The TRAU shall enter the Initial Time Alignment state at the switching-on of the system, when it goes idle (e.g. when receiving the PCM idle pattern after a call release as described in clause 6.3), if loss of frame synchronization is detected, in call modification from data to speech is performed or if BSS internal handover is detected.

In the initial state, the frames shall only be delayed or no change is applied (see note below). The transcoder is able to adjust the time for transmitting the speech frames in steps of 125  $\mu$ s (one speech sample). The CCU calculates the required timing adjustment and returns a frame including the number of 250/500  $\mu$ s steps by which the frames in the downlink direction have to be delayed (binary number in the "Time Alignment" field).

When receiving this information, the TRAU processes this data and sets the "Time Alignment" field in the next downlink frame as ordered and then delays the subsequent frame accordingly.

If the TRAU, in this state, receives an order to advance the next frame 250  $\mu$ s, this order shall be interpreted as "Delay frame 39\*500  $\mu$ s".

When a frame is delayed due to timing adjustments, the TRAU shall fill in the gap between the frames with the appropriate number of binary "1".

After having adjusted the timing, the TRAU shall receive at least three new frames before a new adjustment is made. This in order to avoid oscillation in the regulation.

The TRAU shall change from the Initial Time Alignment state to the Static Time Alignment state when it has performed two subsequent timing adjustments which are less than 500  $\mu$ s (including no change).

The procedure is illustrated in figure 6.1.

#### 6.6.1.1.1.2 Static Time Alignment state

In the Static Time Alignment state, the TRAU performs timing adjustments in single steps of 250  $\mu$ s. The timing may either be delayed (time alignment code 111110, advanced (time alignment code 111111) or not changed (time alignment code 000000).

When receiving an order for adjusting the timing, the transcoder skips or repeats two speech samples in order to achieve the correct timing.

If the timing is to be advanced 250  $\mu$ s, the TRAU sets the "Time Alignment" field in the next downlink frame as ordered and then the 4 last bits of the frame are not transferred (the T-bits).

If the timing is to be delayed, the TRAU sets the "Time Alignment" field in the next downlink frame as ordered and then delays the subsequent frame by adding four binary "1" between the frames.

After having adjusted the timing, the TRAU shall receive at least three new frames before a new adjustment is made.

If, in this state, the TRAU detects a change in the timing of the uplink frames greater than 1ms, it shall enter the Initial Time Alignment state and in that state it may perform an adjustment on the downlink equal to the change detected on the uplink.

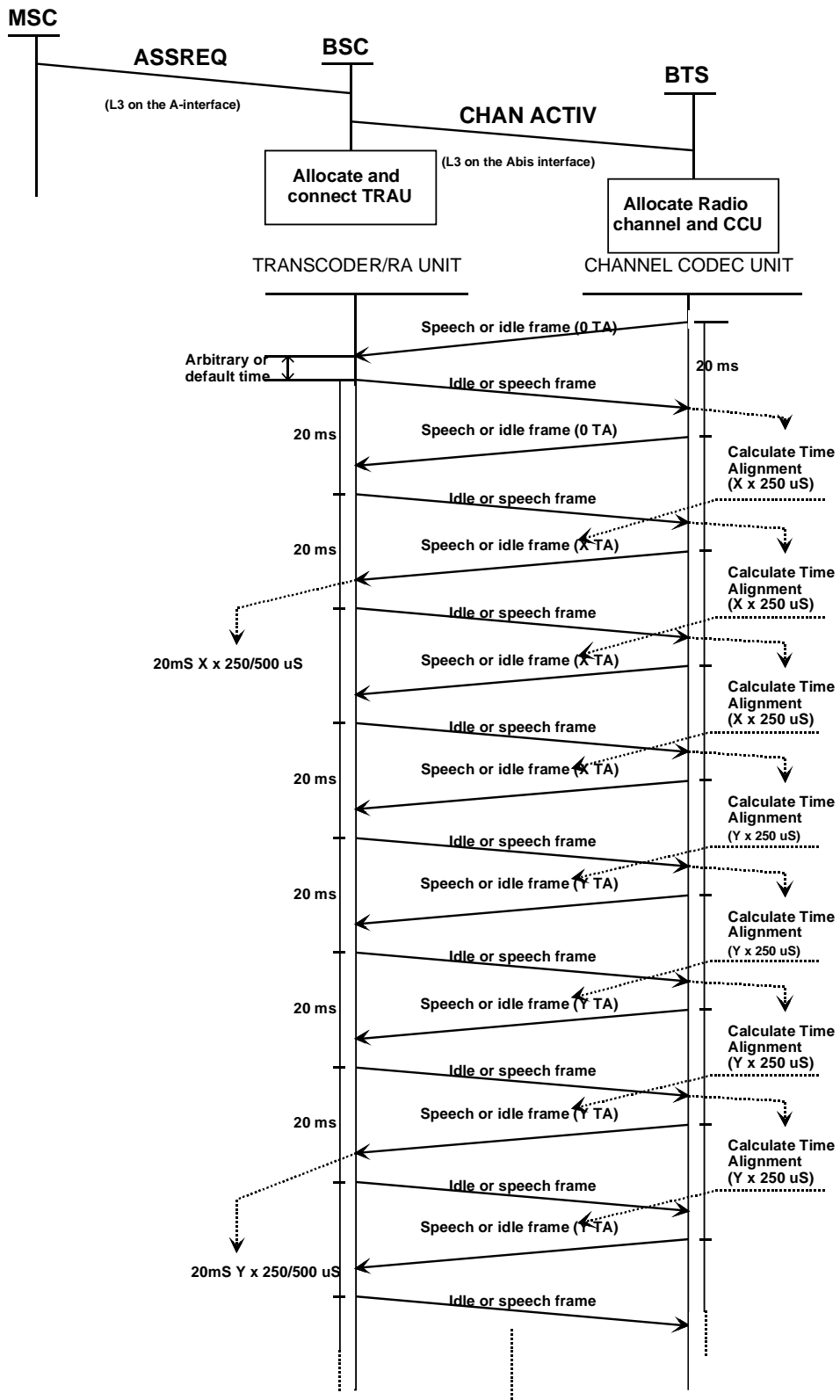

Figure GSM 08.61/6.1: Initial Time Alignment procedure, 16 kbit/s submultiplexing

#### 6.6.1.1.2 Uplink Time Alignment

In order to achieve optimum timing between the Air interface and the terrestrial link, the tail bits of the uplink speech frames may be used for uplink time alignment.

To advance 125  $\mu$ s, the CCU removes the last two tail bits of the uplink TRAU speech frame.

To delay 125  $\mu$ s, the CCU inserts two binary "1" between two uplink TRAU speech frames.

#### 6.6.1.1.3 Initiation at Resource Allocation

When the BTS receives the GSM 08.58 CHANNEL ACTIVATION message from the BSC, with Channel Mode IE indicating speech, it allocates the appropriate radio resources and a Channel Codec Unit (CCU). The CCU then initiates sending of speech frames (or applies the procedure specified in clause 6.5 if speech is not received from the MS) towards the transcoder with normal frame phase for the TDMA channel in question. The "Time Alignment" field in these frames is set to "no change".

The TRAU will now be in the Initial Time Alignment state. When receiving the first frame it shall start sending speech frames towards the BTS with arbitrary or default phase related to the uplink frame phase.

When receiving these frames the CCU calculates the timing adjustment required in order to achieve minimum buffer delay and sets the "Time Alignment" field in the uplink frames accordingly.

The procedures described for the Initial and for the Static Time Alignment states are then followed during the call.

#### 6.6.1.1.4 Time Alignment during Handover

##### 6.6.1.1.4.1 BSS External Handover

For BSS external handover, the procedure described in clause 6.6.1.1.3 should be used by the new BSC/BTS at resource allocation.

##### 6.6.1.1.4.2 BSS Internal Handover

If a BSS internal handover has been performed, the timing of the downlink frames may have to be adjusted several steps of 250/500  $\mu$ s. In order to speed up the alignment of the downlink frames, this must be detected by the TRAU, e.g. by detecting the change in the uplink frame timing as described in clause 6.6.1.1.2. The TRAU should then enter the Initial Time Alignment state and in that state it may perform an adjustment on the downlink equal to the change detected on the uplink.

#### 6.6.1.2 8 kbit/s submultiplexing

For AMR speech on 8 kBit/s submultiplexing the same procedures as for AMR speech on 16 kBit/s submultiplexing shall be applied, see GSM 08.60. Note: For 8 kBit/s submultiplexing the Time Alignment commands are defined only for No\_Speech frames and therefore speech frames may need to be stolen to perform time and phase alignment.

#### 6.6.1.2.1 Downlink Time Alignment

The TRAU must be able to adjust the time for transmitting the downlink TRAU frames in steps of 250  $\mu$ s.

The CCU must be able to calculate the required Time Alignment (TA) with a resolution of 250  $\mu$ s.

The TA requests are in the range of 250  $\mu$ s to 19,75 ms. The CCU calculates the required TA, sends a TA compound request to the TRAU and then starts timer Tta.

A TA compound request consists of up to five consecutive TA requests. The allowed values of TA requests are given in table 6.1.

The CCU does not send TA requests when timer Tta is running. Tta is reset by the CCU when the TRAU has applied the TA compound request. The TRAU performs time adjustment corresponding to the TA compound request.

The CCU can send a new TA compound request as soon as the TRAU has applied the previous TA compound request or Tta has expired.

Tta is a parameter settable by O&M.

NOTE: The timer Tta shall be set taking into account the transmission delay and the TRAU reaction time for the application of the TA compound request.

**Table GSM 08.61/6.1: Allowed values of TA requests**

TA2	TA1	TA0	Value
1	1	1	no change
1	1	0	- 250 $\mu$ s
1	0	1	+ 250 $\mu$ s
0	1	1	+ 500 $\mu$ s
1	0	0	+ 1 ms
0	1	0	+ 3 ms
0	0	1	+ 6 ms
0	0	0	+ 9 ms

When the TRAU detects an uplink transmission error, it ignores the possible TA request contained in the erroneous TRAU frame.

If the timing is to be advanced by 250  $\mu$ s, the TRAU shall not transfer the last two bits of the next downlink TRAU frame (bits T1, T2).

If the timing is to be delayed, the TRAU shall delay the next downlink TRAU frame by inserting the appropriate number of binary "1".

An example of the procedure is illustrated in figure 6.2.

If the TRAU detects a change in the timing of the uplink frames greater than 1 ms, it may perform an adjustment on the downlink equal to the change detected on the uplink.

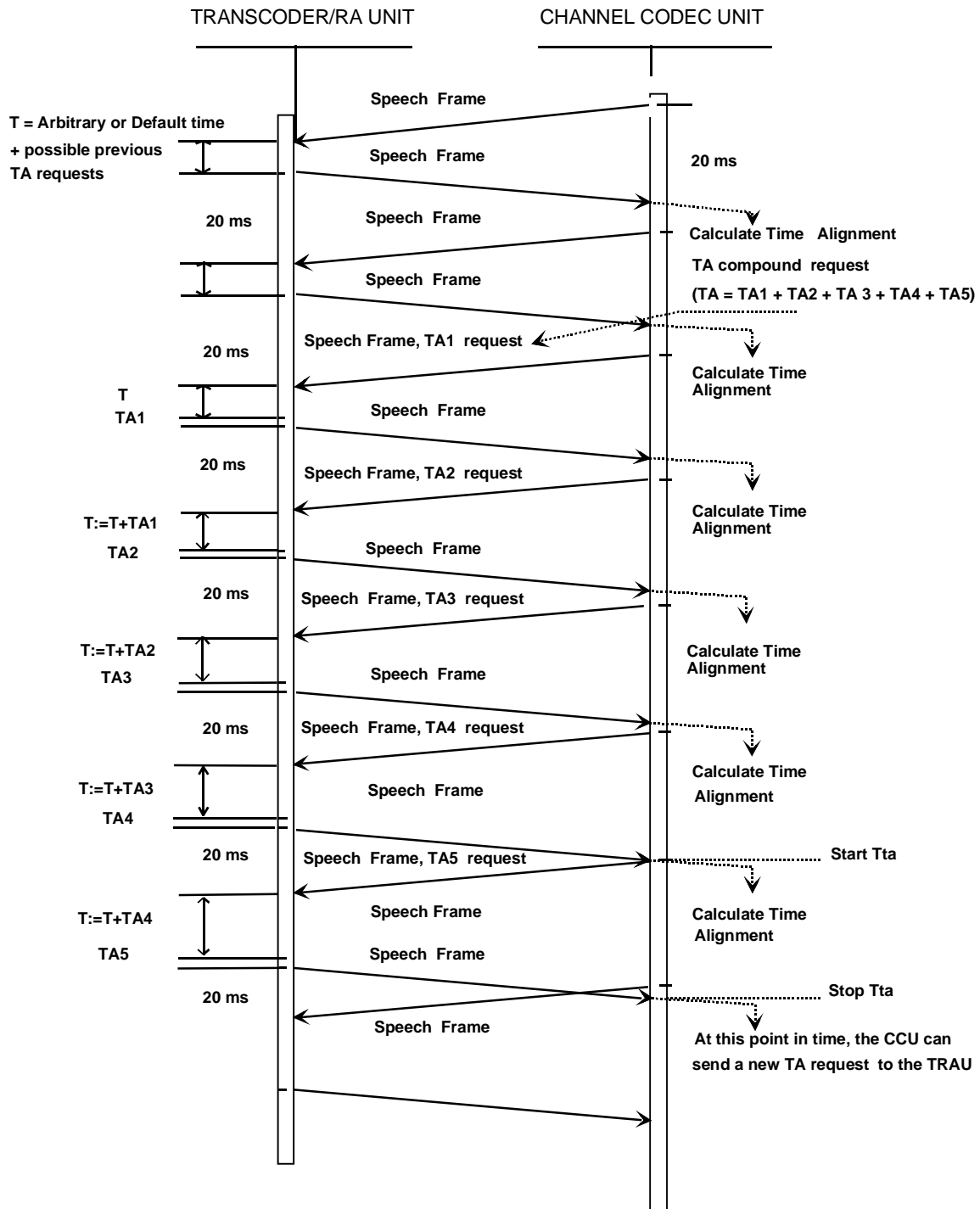

Figure GSM 08.61/6.2: Time Alignment procedure, 8 kbit/s submultiplexing

### 6.6.1.2.2 Uplink Time Alignment

In order to achieve optimum timing between the Air interface and the terrestrial link, the tail bits of the uplink speech frames may be used for uplink time alignment.

To advance 125 μs, the CCU removes the last tail bit (T2) of the uplink TRAU speech frame.

To delay 125 μs, the CCU inserts one binary "1" between two uplink TRAU speech frames.

In case of AMR two tail bits (D126 .. T) are defined for No\_Speech frames, one tail bit (T) for the three lower codec modes (4,75, 5,15 and 5,90) and no tail bits for the higher modes (6,70 and 7,40). To advance by 125  $\mu$ s in the higher codec mode, the CCU may either remove the last data bit (small distortion of the speech signal) or replace a speech frame by a No\_Speech frame (also speech distortion) and then remove the T bit. To delay 125  $\mu$ s, the CCU inserts one binary "1" between two uplink TRAU speech frames.

#### 6.6.1.2.3 Initiation at Resource allocation

When the BTS receives the GSM 08.58 CHANNEL ACTIVATION message from the BSC, with Channel Mode IE indicating speech, it allocates the appropriate radio resources and a CCU. The CCU then initiates sending of TRAU speech frames towards the TRAU with normal frame phase for the TDMA channel in question.

When receiving the first frame, the TRAU shall start sending speech frames towards the CCU with arbitrary or default phase related to the uplink frame phase.

When receiving these frames, the CCU calculates the timing adjustment required in order to achieve minimum buffer delay and sends a timing adjustment request to the TRAU according to the procedure described in clause 6.6.1.2.1.

#### 6.6.1.2.4 Time Alignment during handover

##### 6.6.1.2.4.1 BSS External Handover

For BSS external handover, the procedure described in clause 6.6.1.2.3 should be used by the new BSC/BTS at resource allocation.

##### 6.6.1.2.4.2 BSS Internal Handover

The timing of the downlink frames may have to be adjusted if a BSS internal handover has been performed. In order to speed up the alignment of the downlink frames, this must be detected by the TRAU, e.g. by detecting the change in the uplink frame timing as described in clause 6.6.1.2.1. The TRAU may consequently perform an adjustment on the downlink equal to the change detected on the uplink.

### 6.6.2 Procedures for Discontinuous Transmission (DTX)

For Adaptive Multi-Rate speech see GSM 08.60.

The procedures for comfort noise are described in GSM 06.22, the overall operation of DTX is described in GSM 06.41 and the Voice Activity Detector is described in GSM 06.42.

The downlink DTX Handler function is considered as a part of the TRAU when remote transcoders are applied.

The specification of the DTX Handler is given in GSM 06.41.

#### 6.6.2.1 DTX procedures in the uplink direction

In the comfort noise generation state, the MS will transmit a new traffic frame only every 240 ms (which corresponds to 12 TRAU speech frames). These traffic frames are transferred in the normal way between the CCU and the TRAU. If no valid traffic frames are received, the CCU shall apply the procedure described in clause 6.5. Furthermore the frame classification is done according to the following paragraphs.

##### **16 kbit/s submultiplexing**

In all uplink 320 bit TRAU frames, the BFI (Bad Frame Indicator) indicator, the SID (Silence Descriptor) indicator and the TAF (Time Alignment Flag) indicator are set as output from the Radio Subsystem (Error correction & detection and SID frame detection, see GSM 06.41).

##### **8 kbit/s submultiplexing**

The frame classification is set as output from the Radio Subsystem (Error correction and detection and SID frame detection, see GSM 06.41) in the uplink 160 bit TRAU speech frame (SID frame, see clauses 5.2.1 and 5.2.4.1).



### 6.6.2.2 DTX procedures in the downlink direction

To inform the DTX handler in the remote transcoder whether downlink DTX shall be applied or not, the DTXd bit in the uplink TRAU speech frame is used. The coding is as follows:

DTXd = 0: Downlink DTX shall not be applied;

DTXd = 1: Downlink DTX shall be applied.

Though this parameter is linked with the resource allocation in the BTS at call setup, its value may vary during the connection.

Two consecutive TRAU frames without detected errors and with the same DTXd flag value shall be considered as an indication to change DTX mode.

The SP (Speech) indicator is set as output from the Tx DTX handler (voice activity detection, see GSM 06.41) in the downlink TRAU speech frames (see clause 5.2.4.2).

## 6.7 Procedures for Data Frames

When rate adaption to 64 kbit/s is performed at the BTS (sub-64 kbit/s traffic channels are not used), the rate adaption between the format used on the radio interface and the 64 kbit/s format is made by the RA1/RA1' and the RA2 function as described in GSM 08.20. This is illustrated in figure 6.3.

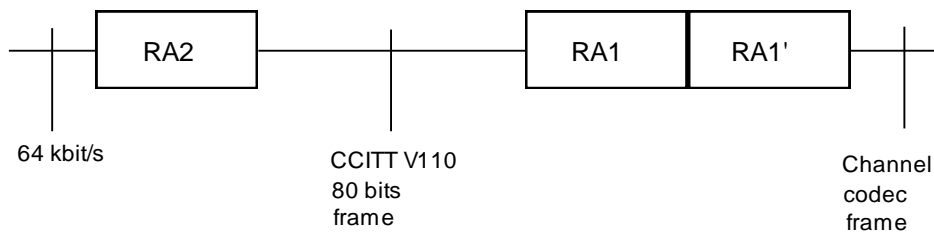

**Figure GSM 08.61/6.3: Rate adaption when performed at the BTS**

When sub-64 kbit/s traffic channels are used, two modified ITU-T V.110 frames are transferred in each TRAU data frame. An additional intermediate rate adaption function, RAA, is applied in order to perform the adaption between the TRAU data frame format and the ITU-T V.110 80 bits frame format. This is illustrated in figure 6.4.

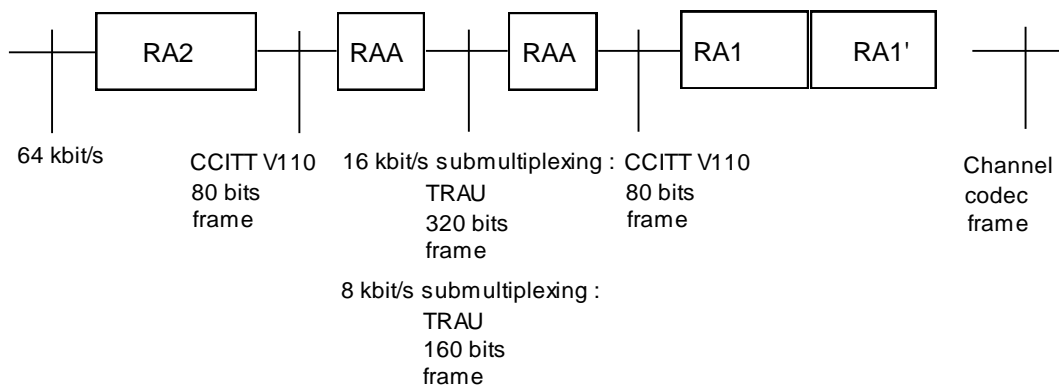

**Figure GSM 08.61/6.4: Rate adaption when sub-64 kbit/s traffic channels are used**

### 6.7.1 The RAA Function

The RAA function performs the adaption between the ITU-T V.110 80 bits frame format and the TRAU data frame format.

When going from the V.110 format to the TRAU data frame format, the synchronization pattern (first octet with all bits coded binary "0" and the 9 bits coded binary "1" in the position 1 of the following octets) of the ITU-T V.110 80 bits frame is stripped off. Two modified V.110 63 bits frames are then transferred in each TRAU data frame as shown in clause 5.1.2 for 16 kbit/s submultiplexing and clause 5.2.2 for 8 kbit/s submultiplexing.

When going from the TRAU data frame format to the V.110 80 bits frame format, the two modified V.110 63 bits frames are separated and the synchronization pattern is again included.

The 80 bits V.110 frame is illustrated in figure 6.5.

Octet no.	Bit number							
	1	2	3	4	5	6	7	8
0	0	0	0	0	0	0	0	0
1	1	D1	D2	D3	D4	D5	D6	D7
2	1	D8	D9	D10	D11	D12	D13	D14
3	1	D15	D16	D17	D18	D19	D20	D21
4	1	D22	D23	D24	D25	D26	D27	D28
5	1	D29	D30	D31	D32	D33	D34	D35
6	1	D36	D37	D38	D39	D40	D41	D42
7	1	D43	D44	D45	D46	D47	D48	D49
8	1	D50	D51	D52	D53	D54	D55	D56
9	1	D57	D58	D59	D60	D61	D62	D63

**Figure GSM 08.61/6.5: ITU-T V.110 80 bits frame**

#### 16 kbit/s submultiplexing

The modified V.110 63 bits frame is illustrated in clause 5.1.2 with:

- the D-bits of the modified V.110 63 bits frame in position 1 of the TRAU data frame;
- the D'-bits of the modified V.110 63 bits frame in position 3 of the TRAU data frame,

corresponding respectively to the D-bits of the V.110 80 bits frame (see figure. 6.5).

#### 8 kbit/s submultiplexing

The modified V.110 63 bits frame is illustrated in clause 5.2.2 with:

- the D-bits of the modified V.110 63 bits frame in position 1 of the TRAU data frame;
- the D'-bits of the modified V.110 63 bits frame in position 2 of the TRAU data frame,

corresponding respectively to the D-bits of the V.110 80 bits frame (see figure. 6.5).

### 6.7.2 The RA1/RA1' Function

This function is described in GSM 04.21.

### 6.7.3 The RA2 Function

This function is described in GSM 04.21.

### 6.7.4 Procedures for 8 kbit/s intermediate rate adaption rate

For 8 kbit/s intermediate rate adaption rate, two modified ITU-T V.110 72 bits frames are transferred in each TRAU data frame. If the data transfer terminates before the TRAU data frame has been completed, the remaining data bit positions in the TRAU data frame should be coded binary "1".

If V.110 frame synchronization has been lost in the downlink direction, the TRAU shall react as if V.110 frames with all data bits coded binary "1" had been received (bits D1 to D63, see clause 6.7.1).

## 6.7.5 Support of Non-Transparent Bearer Applications

The procedures for transfer of non-transparent bearer applications are specified in GSM 08.20. The 240 bit RLP frame is converted to four modified V.110 80 bit frames.

The same conversion is applied when transferred in a TRAU data frame. The TRAU data frames are coded as specified in clause 6.7.4.

## 6.8 Frame Synchronization

### 6.8.1 16 kbit/s submultiplexing

#### 6.8.1.1 Search for Frame Synchronization

The frame synchronization is obtained by means of the first two octets in each frame, with all bits coded binary "0", and the first bit in octet no. 3, 5, 7, 9, ... 39 coded binary "1". The following 35 bit alignment pattern is used to achieve frame synchronization:

00000000	00000000	1XXXXXXXX	XXXXXXXX	1XXXXXXXX	XXXXXXXX	1XXXXXXXX	XXXXXXXX
1XXXXXXXX	XXXXXXXX	1XXXXXXXX	XXXXXXXX	1XXXXXXXX	XXXXXXXX	1XXXXXXXX	XXXXXXXX
1XXXXXXXX	XXXXXXXX	1XXXXXXXX	XXXXXXXX	1XXXXXXXX	XXXXXXXX	1XXXXXXXX	XXXXXXXX
1XXXXXXXX	XXXXXXXX	1XXXXXXXX	XXXXXXXX	1XXXXXXXX	XXXXXXXX	1XXXXXXXX	XXXXXXXX
1XXXXXXXX	XXXXXXXX	1XXXXXXXX	XXXXXXXX	1XXXXXXXX	XXXXXXXX	1XXXXXXXX	XXXXXXXX

#### 6.8.1.2 Frame Synchronization After Performing Downlink Timing Adjustments

If the timing of the downlink TRAU speech frames is adjusted, the adjustment is indicated in bits C6 - C11 as described in clauses 6.6.1.1.1 and 6.6.1.1.2. The frame synchronization unit of the CCU shall change its frame synchronization window accordingly.

#### 6.8.1.3 Frame Synchronization Monitoring and Recovery

The monitoring of the frame synchronization shall be a continuous process using the same procedure as for initial detection.

Loss of frame synchronization shall not be assumed unless at least three consecutive frames, each with at least one framing bit error, are detected.

When it detects a framing bit error, the TRAU uses the control bit UFE (Uplink Frame Error) in the next downlink TRAU frame to indicate it to the CCU. When the CCU receives a TRAU frame indicating an Uplink Frame Error and which has no errors on the synchronization pattern and the control bits, it starts a timer TsyncU.

If loss of frame synchronization is detected by the CCU it starts a timer TsyncD. If TsyncD or TsyncU expires before frame synchronization is again obtained the call shall be released as specified in GSM 08.58 with the cause field set to "Remote Transcoder Failure".

TsyncD is reset every time frame synchronization is again obtained.

TsyncU is reset every time three consecutive TRAU frames are received without Uplink Frame Error indication, without errors on the frame synchronization pattern and on the control bits.

TsyncD and TsyncU are parameters set by O&M (default value = 1 second).

## 6.8.2 8 kbit/s submultiplexing

### 6.8.2.1 Search for Frame Synchronization

#### 6.8.2.1.1 For Half Rate speech and data

The frame synchronization is obtained by a 28 bit pattern which is indicated below by all the bits set to binary "0" or binary "1".

```

0 0 0 0 0 0 0 0   1 x x x x x x x   0 1 x x x x x x   1 x x x x x x x
1 x x x x x x x   1 x x x x x x x   1 x x x x x x x   1 x x x x x x x
1 x x x x x x x   1 x x x x x x x   1 x x x x x x x   1 x x x x x x x
1 x x x x x x x   1 x x x x x x x   1 x x x x x x x   1 x x x x x x x
1 x x x x x x x   1 x x x x x x x   1 x x x x x x x   1 x x x x x x x

```

#### 6.8.2.1.2 For Adaptive Multi-Rate speech

The frame synchronisation for No\_Speech frames and the speech frames of the three lower codec modes is obtained by a 28 bit pattern, which is indicated below by all the bits set to binary "0" or binary "1".

Initial Synchronisation is started after resource allocation and after loss of synchronisation. Initial Synchronisation shall be a continuous process. Synchronisation shall be regarded as obtained if at least one complete frame is detected with all 28 synchronisation bits and all control and CRC bits correct:

```

0 0 0 0 0 0 0 0   1 x x x x x x x   1 x x x x x x x   0 1 x x x x x x
1 x x x x x x x   1 x x x x x x x   1 x x x x x x x   1 x x x x x x x
1 x x x x x x x   1 x x x x x x x   1 x x x x x x x   1 x x x x x x x
1 x x x x x x x   1 x x x x x x x   1 x x x x x x x   1 x x x x x x x
1 x x x x x x x   1 x x x x x x x   1 x x x x x x x   1 x x x x x x x

```

The frame synchronisation for the speech frames for codec mode 6,70 kBit/s is obtained by a 21 bit pattern, which is indicated below by all the bits set to binary "0" or binary "1". This codec mode may be used for Initial Synchronisation, the preferred solution is, however, to user a lower code mode or No\_Speech frames. Initial Synchronisation is started after resource allocation and after loss of synchronisation. Initial Synchronisation shall be a continuous process. Synchronisation shall be regarded as obtained if at least one complete frame is detected with all 21 synchronisation bits and all control and CRC bits correct:

```

0 0 0 0 0 0 0 0   1 x x x x x x x   1 x x x x x x x   1 x x x x x x x
1 x x x x x x x   0 x x x x x x x   1 x x x x x x x   x x x x x x x x
1 x x x x x x x   x x x x x x x x   1 x x x x x x x   x x x x x x x x
1 x x x x x x x   x x x x x x x x   1 x x x x x x x   x x x x x x x x
1 x x x x x x x   x x x x x x x x   1 x x x x x x x   x x x x x x x x

```

The frame synchronisation for the speech frames for codec mode 7,40 kBit/s is obtained by a 6 bit pattern, which is indicated below by all the bits set to binary "0" or binary "1". This codec mode shall not be used for Initial Synchronisation, the recommended solution is to user a lower code mode or No\_Speech frames:

```

0 0 1 x x x x x   0 x x x x x x x   1 x x x x x x x   0 x x x x x x x
x x x x x x x x   x x x x x x x x   x x x x x x x x   x x x x x x x x
x x x x x x x x   x x x x x x x x   x x x x x x x x   x x x x x x x x
x x x x x x x x   x x x x x x x x   x x x x x x x x   x x x x x x x x
x x x x x x x x   x x x x x x x x   x x x x x x x x   x x x x x x x x

```

### 6.8.2.2 Frame Synchronization Monitoring and Recovery

#### 6.8.2.2.1 For Half Rate speech and data

Same as clause 6.8.1.3.

### 6.8.2.2.2 For Adaptive Multi-Rate speech

The monitoring of the frame synchronisation shall be a continuous process. A frame, respectively a subframe, shall be regarded as correctly received, if synchronisation was established before the beginning of the frame (subframe) and all synchronisation, control and CRC bits within the frame (subframe) are correct. Since the Adaptive Multi-Rate codec may change its codec mode every 40 ms, the monitoring of frame synchronisation shall take these possible changes into account.

Loss of frame synchronisation shall not be assumed unless at least three consecutive frames, each with at least one framing bit error, are detected. However, for every frame with detected errors a No\_Speech frame shall be sent back with the UFE (DFE) bits set, see clause 6.9.2.1. The receiver shall in addition check, whether the synchronisation pattern can be detected plus or minus one position shifted with respect to the expected position within the bit stream. If synchronisation can not be found by this within three frames, then Initial Synchronisation shall be performed.

When it detects a framing bit error, the TRAU uses the control bit UFE (Uplink Frame Error) in the next downlink TRAU frame to indicate it to the CCU. When the CCU receives a TRAU frame indicating an Uplink Frame Error and which has no errors on the synchronization pattern and the control bits, it starts a timer TsyncU.

If loss of frame synchronization is detected by the CCU it starts a timer TsyncD. If TsyncD or TsyncU expires before frame synchronization is again obtained the call shall be released as specified in GSM 08.58 with the cause field set to "Remote Transcoder Failure".

TsyncD is reset every time frame synchronization is again obtained.

TsyncU is reset every time three consecutive TRAU frames are received without Uplink Frame Error indication, without errors on the frame synchronization pattern and on the control bits.

TsyncD and TsyncU are parameters set by O&M (default value = 1 second).

## 6.9 Correction/detection of bit errors

### 6.9.1 16 kbit/s submultiplexing

In case of AMR speech see GSM 08.60.

#### 6.9.1.1 Error Detection on the Control Bits

In order to reduce the possibility of misinterpretation of control information due to bit errors, the following procedure should be followed:

##### 6.9.1.1.1 General Procedure

If any undefined combination of the C-bits is received (see clause 5.1.4), the TRAU frame shall be handled as defined in clause 6.9.1.2.

##### 6.9.1.1.2 Frames for Half Rate speech

In addition to the general procedure described in the previous clause, the following procedure should be followed for the speech frames:

Bits C6 - C11: Time Alignment.

The full range of the time alignment adjustment should only be applied when the TRAU is in the Initial Time Alignment state (see clauses 6.6.1.1.1.1 and 6.6.1.1.1.2).

If, in the Static Time Alignment state, a time alignment order is received indicating an adjustment of more than 250  $\mu$ s, the next downlink frame should be delayed only one 250  $\mu$ s step.

If an uplink frame is received with the "Time Alignment" field set to an unused value (101000...111101), this value should be interpreted as "no change".

### 6.9.1.2 Handling of frames received with errors for Half Rate speech and data

If a TRAU frame is received in the uplink or downlink with detectable errors in the control bits, then the control information shall be ignored and the control information from the previous received TRAU frame shall be used to handle the speech or data bits as if no error had been detected.

If frame synchronization has been lost in the uplink direction, the TRAU shall:

- for speech, mute the decoded speech as if it has received TRAU frames with errors (cf. GSM 06.21);
- for data, send idle V.110 frames as defined in GSM 08.20 to the MSC interworking unit.

The CCU shall follow the procedure specified in clause 6.5:

- if frame synchronization has been lost in the downlink direction;
- if a CRC error is detected (bits CRC0-CRC2) in a downlink TRAU speech frame.

If a CRC error is detected (bits CRC0-CRC2) in a uplink TRAU speech frame, the TRAU speech frame shall be regarded as bad and the TRAU shall apply the procedure defined in GSM 06.21.

## 6.9.2 8 kbit/s submultiplexing

### 6.9.2.1 Error Detection on the Control Bits

#### **In case of Half Rate speech and Data:**

Error detection is made on control bits C1-C4 with the parity bit C5 (see clause 5.2.4) for all types of 160 bit TRAU frames. Additionally, for TRAU speech frames, error detection is made on control bits XC1-XC5 with the parity bit XC6.

If the following occurs:

- parity bit C5 and/or parity bit XC6 are wrong;
- any undefined combination of the control bits is received (see clause 5.2.4) with a correct parity bit.

The TRAU frame shall be handled as defined in clause 6.9.1.2.

#### **In case of Adaptive Multi-Rate speech:**

If errors are detected within the Sync bits, the Control bits or by the CRC bits, then the frame shall be regarded as invalid. If the error is detected in uplink direction, then the TRAU shall perform error concealment as for any No\_Data frame (see GSM 06.92). If the error is detected in downlink direction, then the BTS shall handle this with respect to the air interface as described in clause 6.5, respectively in GSM 08.60.

A No\_Speech frame with the UFE set to "Uplink Frame Received with Errors" (if the error is detected in uplink), respectively a No\_Speech frame with DFE set to "Downlink Frame Received with Errors" (if the error is detected in downlink) shall be sent back for every detected invalid frame. The other side, when receiving a No\_Speech frame with the UFE, respectively DFE bit set shall respond with a No\_Speech Frame, too, where the DFE respectively UFE bit is not set (unless the error occurred in both directions). In this way the fastest possible re-synchronisation shall be ensured. In case of ongoing TFO these frames may transmit the configuration parameters in addition (see GSM 08.62).

### 6.9.2.2 Handling of frames received with errors

In case of Half Rate speech and Data: Same as clause 6.9.1.2.

In case of Adaptive Multi-Rate speech: Same as clause 6.9.2.1.

## 6.10 Procedures for Operation & Maintenance

The general procedures for Operation and Maintenance are described in GSM 12.21.

If the transcoders are positioned outside the BTS, some O&M functions will be required for the TRAU and the CCU. In particular this applies for transcoders positioned at the MSC site.

The transcoders outside the BTS are considered a part of the BSC, and the O&M functions for the TRAU should therefore be implemented in the BSC.

The CCU is a part of the BTS and the O&M functions for this unit should therefore be implemented in the BTS.

### 6.10.1 Transfer of O&M Information Between the TRAU and the BSC

The transfer of O&M information between the BSC and the TRAU is possible to do in two ways. Either it is handled directly between the BSC and the TRAU or a BTS is used as a message transfer point. The choice between the two methods is up to the manufacturer of the BSC:

- i) The transfer of O&M information between the BSC and the TRAU is handled internally by the BSC. The O&M signalling between the TRAU and the BSC may either be handled by proprietary BSC solutions or the O&M TRAU frames defined for 16 kbit/s submultiplexing in clauses 5.1.3 and 5.1.4.3 and for 8 kbit/s submultiplexing in clauses 5.2.3 and 5.2.4 could be used. In the latter case, the BSC has to act as a terminal for the O&M TRAU frames sent between the TRAU and the BSC;
- ii) The O&M information between the TRAU and the BSC is transferred using O&M TRAU frames between the TRAU and the CCU in a BTS. The BTS then acts as a relay function between the O&M TRAU frames and the associated O&M messages sent between the BTS and the BSC.

### 6.10.2 Procedures in the TRAU

If O&M information between the TRAU and the BSC is transferred using O&M TRAU frames between the CCU in a BTS and the TRAU, the TRAU sends O&M TRAU frames periodically until the identical O&M TRAU frame is received as an acknowledgement. The period is at least  $64 \cdot 20\text{ms}$  (1,28 sec).

In case of fault conditions, when no immediate action is required, the TRAU may send O&M frames indicating the fault.

### 6.10.3 Procedures in the BSC

The BSC should be able to detect a faulty TRAU, take it out of service and give an indication to O&M. A faulty TRAU could be detected e.g. by routine tests, alarms from the TRAU, release of call initiated by the BTS due to remote transcoder failure etc. How this is handled by the BSC is regarded as a BSC internal matter.

#### 6.10.3.1 Use of O&M Frames

The use and coding of O&M TRAU frames is left to the implementor of the BSC/TRAU.

If O&M TRAU frames are used, they are always carrying:

- 264 data bits in case of 16 kbit/s submultiplexing;
- 120 data bits in case of 8 kbit/s submultiplexing.

Any corresponding O&M message between the BSC and the BTS shall always carry:

- all 264 O&M data bits in case of 16 kbit/s submultiplexing;
- 120 data bits in case of 8 kbit/s submultiplexing.

### 6.10.4 Procedures in the BTS

If a CCU in a BTS receives O&M TRAU frames from the TRAU, the BTS shall:

- send the identical frame to the TRAU for acknowledgement; and
- put all the data bits from the received frames into an appropriate O&M message and send it to the BSC.

If the CCU receives O&M TRAU frames during a speech or data call then the procedure described in clause 6.5 shall apply.

If receiving an O&M message from the BSC, carrying TRAU O&M information, the BTS puts all the data bits from the received message into an O&M TRAU frame and then the CCU allocated to the addressed connection sends the frame to the TRAU in one single O&M TRAU frame. Repetition is done according to GSM 12.21

In case of a faulty CCU, the O&M procedures are BTS internal.



## Annex A (informative): Change History

Change history					
SMG No.	TDoc. No.	CR. No.	Section affected	New version	Subject/Comments
SMG#13				4.0.2	ETSI Publication
SMG#20				5.0.0	Release 1996 version
SMG#20				5.0.1	ETSI version change
SMG#27				6.0.0	Release 1997 version
SMG#29				7.0.0	Release 1998 version
SMG#30	580/99	A002		7.1.0	Introduction of AMR
				7.1.1	Correction of CR implementation
SMG#30bis	807/99	A003	5.2, 6.6	7.2.0	Support of AMR-TFO
			Second instance of 5.2.1.2.3 → 5.2.1.2.4	7.2.1	Editorial correction to clause numbering
SMG#31				8.0.0	Release 1999 version
				8.0.1	Update to Version 8.0.1 for Publication

Change history							
Date	TSG GERAN#	TSG Doc.	CR	Rev	Subject/Comment	Old	New
2002-02	08	GP-020178	A005		Correct synchronisation description for HR_AMR	8.0.1	8.1.0