

ETSI EN 301 703 v7.0.2 (1999-12)

European Standard (Telecommunications series)

**Digital cellular telecommunications system (Phase 2+);
Adaptive Multi-Rate (AMR); Speech processing functions;
General description
(GSM 06.71 version 7.0.2 Release 1998)**



GSM®
GLOBAL SYSTEM FOR
MOBILE COMMUNICATIONS

ETSI 

Reference

DEN/SMG-110671Q7

Keywords

Digital cellular telecommunications system,
Global System for Mobile communications
(GSM)

ETSI

Postal address

F-06921 Sophia Antipolis Cedex - FRANCE

Office address

650 Route des Lucioles - Sophia Antipolis
Valbonne - FRANCE
Tel.: +33 4 92 94 42 00 Fax: +33 4 93 65 47 16
Siret N° 348 623 562 00017 - NAF 742 C
Association à but non lucratif enregistrée à la
Sous-Préfecture de Grasse (06) N° 7803/88

Internet

secretariat@etsi.fr
Individual copies of this ETSI deliverable
can be downloaded from
<http://www.etsi.org>
If you find errors in the present document, send your
comment to: editor@etsi.fr

Important notice

This ETSI deliverable may be made available in more than one electronic version or in print. In any case of existing or perceived difference in contents between such versions, the reference version is the Portable Document Format (PDF). In case of dispute, the reference shall be the printing on ETSI printers of the PDF version kept on a specific network drive within ETSI Secretariat.

Copyright Notification

No part may be reproduced except as authorized by written permission.
The copyright and the foregoing restriction extend to reproduction in all media.

© European Telecommunications Standards Institute 1999.
All rights reserved.

Contents

Intellectual Property Rights.....	4
Foreword	4
1 Scope	5
2 References	5
3 Definitions and abbreviations	6
3.1 Definitions	6
3.2 Abbreviations	6
4 General.....	6
5 Adaptive multi-rate speech channel transcoding.....	8
5.1 Full rate channel.....	8
5.2 Half rate channel	9
6 Adaptive multi-rate speech channel discontinuous transmission (DTX).....	9
7 Adaptive multi-rate speech channel Voice Activity Detection (VAD)	10
8 Adaptive multi-rate speech channel comfort noise insertion	10
9 Adaptive multi-rate speech channel lost speech frame substitution and muting	11
10 Adaptive multi-rate codec homing.....	11
History.....	12

Intellectual Property Rights

IPRs essential or potentially essential to the present document may have been declared to ETSI. The information pertaining to these essential IPRs, if any, is publicly available for **ETSI members and non-members**, and can be found in SR 000 314: "*Intellectual Property Rights (IPRs); Essential, or potentially Essential, IPRs notified to ETSI in respect of ETSI standards*", which is available from the ETSI Secretariat. Latest updates are available on the ETSI Web server (<http://www.etsi.org/ipr>).

Pursuant to the ETSI IPR Policy, no investigation, including IPR searches, has been carried out by ETSI. No guarantee can be given as to the existence of other IPRs not referenced in SR 000 314 (or the updates on the ETSI Web server) which are, or may be, or may become, essential to the present document.

Foreword

This European Standard (Telecommunications series) has been produced by Special Mobile Group (SMG).

The present document introduces the Adaptive Multi-Rate (AMR) speech traffic channels within the digital cellular telecommunications system.

The contents of the present document is subject to continuing work within SMG and may change following formal SMG approval. Should SMG modify the contents of the present document it will be re-released with an identifying change of release date and an increase in version number as follows:

Version 7.x.y

where:

- 7 indicates Release 1998 of GSM Phase 2+
- x the second digit is incremented for all changes of substance, i.e. technical enhancements, corrections, updates, etc.
- y the third digit is incremented when editorial only changes have been incorporated in the specification.

National transposition dates	
Date of adoption of this EN:	3 December 1999
Date of latest announcement of this EN (doa):	31 March 2000
Date of latest publication of new National Standard or endorsement of this EN (dop/e):	30 September 2000
Date of withdrawal of any conflicting National Standard (dow):	30 September 2000

1 Scope

The present document is an introduction to GSM 06.90 [7], GSM 06.91 [8], GSM 06.92 [9], GSM 06.93 [10] and GSM 06.94 [11] specifications dealing with the speech processing functions in the adaptive multi-rate channel of the GSM system. A general overview of the speech processing functions is given, with reference to the documents where each function is specified in detail.

2 References

The following documents contain provisions which, through reference in this text, constitute provisions of the present document.

- References are either specific (identified by date of publication, edition number, version number, etc.) or non-specific.
- For a specific reference, subsequent revisions do not apply.
- For a non-specific reference, the latest version applies.
- A non-specific reference to an ETS shall also be taken to refer to later versions published as an EN with the same number.
- For this Release 1998 document, references to GSM documents are for Release 1998 versions (version 7.x.y).

- [1] GSM 01.04: "Digital cellular telecommunications system (Phase 2+); Abbreviations and acronyms".
- [2] GSM 03.50: "Digital cellular telecommunications system (Phase 2+); Transmission planning aspects of the speech service in the GSM Public Land Mobile Network (PLMN) system".
- [3] GSM 05.09: "Digital cellular telecommunications system (Phase 2+); Link adaptation".
- [4] GSM 05.03: "Digital cellular telecommunications system (Phase 2+); Channel coding".
- [5] GSM 06.73: "Digital cellular telecommunications system (Phase 2+); ANSI-C code for the GSM Adaptive Multi-Rate speech codec".
- [6] GSM 06.74: "Digital cellular telecommunications system (Phase 2+); Test sequences for the GSM Adaptive Multi-Rate speech codec".
- [7] GSM 06.90: "Digital cellular telecommunications system (Phase 2+); Adaptive Multi-Rate speech transcoding".
- [8] GSM 06.91: "Digital cellular telecommunications system (Phase 2+); Substitution and muting of lost frame for Adaptive Multi-Rate speech traffic channels".
- [9] GSM 06.92: "Digital cellular telecommunications system (Phase 2+); Comfort noise aspects for Adaptive Multi-Rate speech traffic channels".
- [10] GSM 06.93: "Digital cellular telecommunications system (Phase 2+); Discontinuous transmission (DTX) for Adaptive Multi-Rate speech traffic channels".
- [11] GSM 06.94: "Digital cellular telecommunications system (Phase 2+); Voice Activity Detection (VAD) for Adaptive Multi-Rate speech traffic channels".

3 Definitions and abbreviations

3.1 Definitions

Definition of terms used in the present document can be found in GSM 06.90 [7], GSM 06.91 [8], GSM 06.92 [9], GSM 06.93 [10] and GSM 06.94 [11].

3.2 Abbreviations

For the purposes of the present document, the following abbreviations apply:

ACELP	Algebraic Code Excited Linear Prediction
AMR	Adaptive Multi-Rate
BFI	Bad Frame Indication
BSS	Base Station System
BTS	Base Transceiver Station
CHD	Channel Decoder
CHE	Channel Encoder
DL	Down Link
DTX	Discontinuous Transmission
ETS	European Telecommunication Standard
GSM	Global System for Mobile communications
ITU-T	International Telecommunication Union – Telecommunication standardisation sector (former CCITT)
MS	Mobile Station
PCM	Pulse Code Modulated
PLMN	Public Land Mobile Network
PSTN	Public Switched Telephone Network
RF	Radio Frequency
RSS	Radio SubSystem
RX	Receive
SACCH	Slow Associated Control Channel
SID_FIRST	Speech end marker
SID_UPD	Silence Descriptor (background descriptor)
SPD	Speech Decoder
SPE	Speech Encoder
TC	Transcoder
TRAU	TRanscoding and Rate Adaptation Unit
TX	Transmit
UL	Up Link

For abbreviations not given in this subclause, see GSM 01.04 [1].

4 General

Figure 1 presents a reference configuration where the various speech processing functions are identified. In this figure, the relevant documents for each function are also indicated.

In

Figure 1, the audio parts including analogue to digital and digital to analogue conversion are included, to show the complete speech path between the audio input/output in the Mobile Station (MS) and the digital interface of the PSTN. The detailed specification of the audio parts are contained in GSM 03.50 [2]. These aspects are only considered to the extent that the performance of the audio parts affect the performance of the speech transcoder. Note that the inband

signalling is not shown in Figure 1, refer to Figure 2. The mode indications (UL codec mode and DL codec mode) are used to select the mode of the speech encoder and speech decoder in Figure 1.

Figure 2 presents a general block diagram of the overall AMR system for uplink and downlink over the same radio interface. Mobile Station (MS), Base Tranceiver Station (BTS) and Transcoding and Rate Adaptor Unit (TRAU) are shown in the figure. The detailed specification of AMR link adaptation, channel quality estimation and inband signalling is given in GSM 05.09 [3]. The AMR multirate adaptation is based on quality measurements of the radio channel. The measurements are processed to give the UL Quality Indicator and the DL Quality Indicator. The UL Quality Indicator is mapped to an UL Mode Command and the DL Quality Indicator is mapped to a DL Mode Request in the BTS and MS, respectively. The UL Mode Command and the DL Mode Request are sent to the transmitter using the reverse link. UL codec mode and DL Mode Request are sent as inband signals in the uplink radio channel. DL codec mode and UL Mode Command are sent as inband signals in the downlink channel.

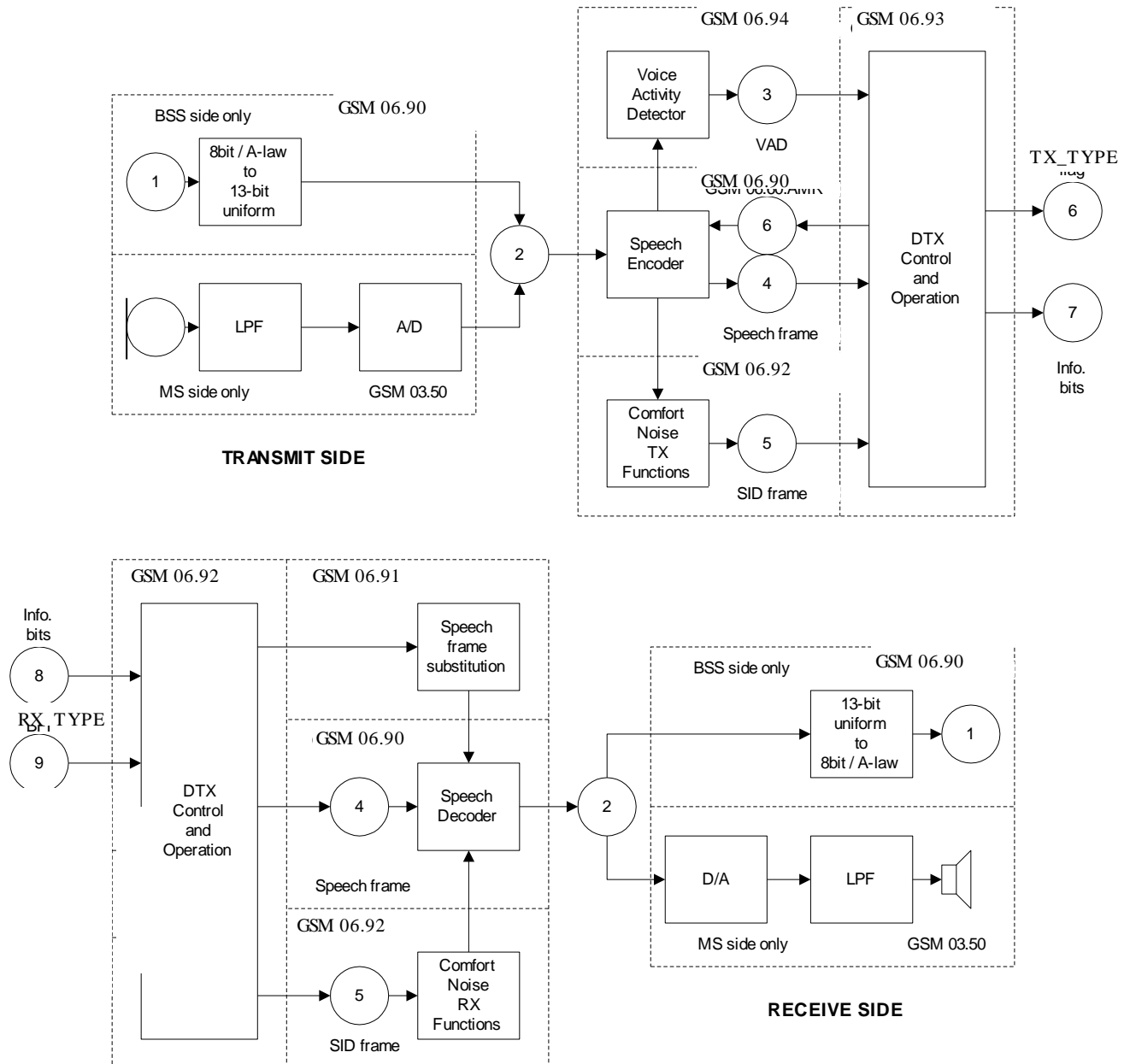

Figure 1: Overview of audio processing functions

- 1) 8-bit A-law or μ -law PCM (ITU-T recommendation G.711), 8 000 samples/s;
- 2) 13-bit uniform PCM, 8 000 samples/s;

- 3) Voice Activity Detector (VAD) flag;
- 4) Encoded speech frame, 50 frames/s, number of bits/frame depending on the AMR codec mode;
- 5) Silence Descriptor (SID) frame (marked SID_FIRST or SID_UPD);
- 6) TX_TYPE, 2 bits, indicates whether information bits are available and if they are speech or SID information;
- 7) Information bits delivered to the radio subsystem;
- 8) Information bits received from the radio subsystem;
- 9) RX_TYPE, the type of frame received quantized into three bits, (classified by the RSS).

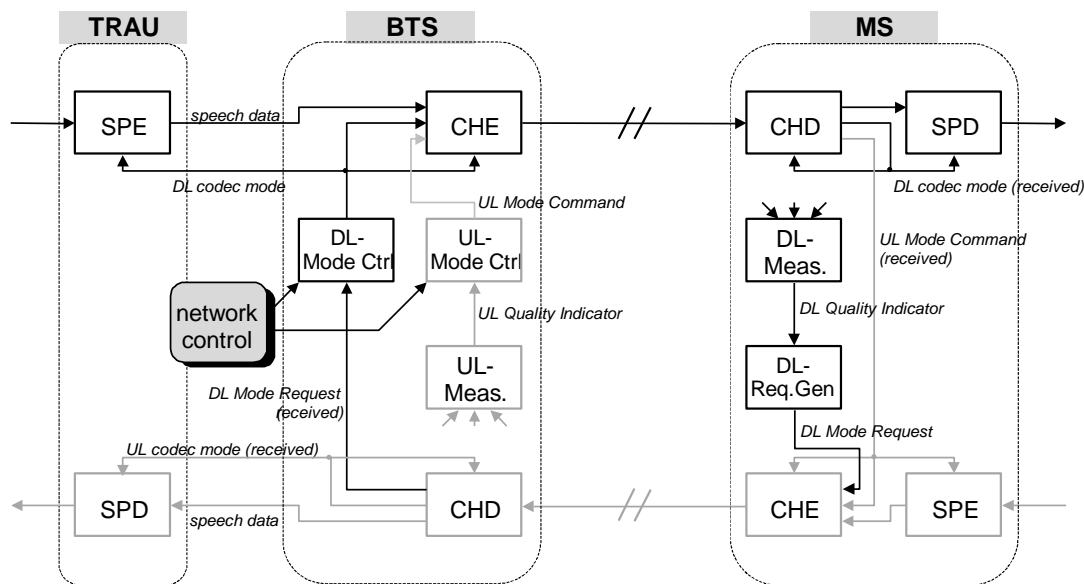

Figure 2: Block diagram of the AMR system.

5 Adaptive multi-rate speech channel transcoding

GSM 06.90 [7] describes the adaptive multi-rate speech codec and GSM 06.73 [8] defines the ANSI-C code, thus enabling the verification of compliance to GSM 06.90 [7] to a high degree of confidence by use of a set of digital test sequences given in GSM 06.74 [6].

5.1 Full rate channel

As shown in

Figure 1, the speech encoder takes its input as a 13-bit uniform Pulse Code Modulated (PCM) signal either from the audio part of the Mobile Station or on the network side, from the Public Switched Telephone Network (PSTN) via an 8-bit A-law or μ -law to 13-bit uniform PCM conversion. The encoded speech at the output of the speech encoder is delivered to the channel coding function defined in GSM 05.03 [4] to produce an encoded block consisting of 456 bits leading to a gross bit rate of 22.8 kbit/s.

In the receive direction, the inverse operations take place. GSM 06.90 [7] describes the detailed mapping between input blocks of 160 speech samples in 13-bit uniform PCM format to encoded blocks (in which the number of bits depends on the used codec mode) and from these to output blocks of 160 reconstructed speech samples. The coding scheme is Multi-Rate Algebraic Code Excited Linear Prediction. The bit-rates of the source codec for the adaptive multi-rate full rate channel (TCH/AFS) are listed in Table 1. An adaptive multi-rate compliant MS shall support all full rate source rates listed in Table 1.

5.2 Half rate channel

As shown in

Figure 1, the speech encoder takes its input as a 13-bit uniform Pulse Code Modulated (PCM) signal either from the audio part of the Mobile Station or on the network side, from the Public Switched Telephone Network (PSTN) via an 8-bit A-law or μ -law to 13-bit uniform PCM conversion. The encoded speech at the output of the speech encoder is delivered to the channel coding function defined in GSM 05.03 [4] to produce an encoded block consisting of 228 bits leading to a gross bit rate of 11.4 kbit/s.

In the receive direction, the inverse operations take place. GSM 06.90 [7] describes the detailed mapping between input blocks of 160 speech samples in 13-bit uniform PCM format to encoded blocks (in which the number of bits depends on the used codec mode) and from these to output blocks of 160 reconstructed speech samples. The coding scheme is Multi-Rate Algebraic Code Excited Linear Prediction. The bit-rates of the source codec for the adaptive multi-rate half rate channel (TCH/AHS) are listed in Table 1. An adaptive multi-rate compliant MS supporting the half rate mode of the adaptive multi-rate speech channel shall support all half rate source rates listed in Table 1.

Table 1: Source codec bit-rates for TCH/AFS and TCH/AHS channels

Channel	Source codec bit-rate
TCH/AFS	12.2 kbit/s (GSM EFR)
	10.2 kbit/s
	7.95 kbit/s
	7.40 kbit/s (IS-641)
	6.70 kbit/s
	5.90 kbit/s
	5.15 kbit/s
TCH/AHS	4.75 kbit/s
	7.95 kbit/s
	7.40 kbit/s (IS-641)
	6.70 kbit/s
	5.90 kbit/s
	5.15 kbit/s
	4.75 kbit/s
NOTE: IS-641 is the TIA/EIA IS-641 TDMA Enhanced Full Rate SpeechCodec.	

6 Adaptive multi-rate speech channel discontinuous transmission (DTX)

During a normal phone conversation, the participants alternate so that, on the average, each direction of transmission is occupied about 50 % of the time. Discontinuous transmission (DTX) is a mode of operation where the transmitters are switched on only for those frames which contain useful information. This may be done for the following two purposes:

- 1) in the MS, battery life will be prolonged or a smaller battery could be used for a given operational duration;
- 2) the average interference level over the air interface is reduced, leading to better Radio Frequency (RF) spectrum efficiency.

The overall DTX mechanism is implemented in the DTX handlers (Transmit (TX) and Receive (RX)) described in GSM 06.93 [10] and requires the following functions:

- a Voice Activity Detector (VAD) on the TX side, see GSM 06.94 [11];
- evaluation of the background acoustic noise on the TX side, in order to transmit characteristic parameters to the RX side, see GSM 06.92 [9];
- generation of comfort noise on the RX side during periods where the radio transmission is turned off, see GSM 06.92 [9].

The transmission of comfort noise information to the RX side is achieved by means of a Silence Descriptor (SID) frame. A SID frame is transmitted at the end of speech bursts and serves as an end of speech marker for the RX side. In order to update the comfort noise characteristics at the RX side, SID frames are transmitted at regular intervals also during speech pauses. This also serves the purpose of improving the measurement of the radio link quality by the radio subsystem (RSS).

The DTX handlers interwork with the RSS using flags. The RSS is in control of the actual transmitter keying on the TX side, and performs various pre-processing functions on the RX side. This is described in GSM 06.93 [10].

The 2 bit field TX_TYPE indicates whether information bits are speech or SID information or if there is no information. The TX_TYPE field is calculated from the VAD flag by the TX DTX handler. When SID information is transmitted the operation of the speech encoder is modified to reduce the remaining computation for that frame. This is described in GSM 06.92 [9].

7 Adaptive multi-rate speech channel Voice Activity Detection (VAD)

The adaptive multi-rate VAD function is described in GSM 06.94 [11].

The input to the VAD is a set of parameters computed by the adaptive multi-rate speech encoder defined in GSM 06.90 [7]. The VAD uses this information to decide whether each 20 ms speech coder frame contains speech or not. Note that the VAD flag is an input to the TX DTX handler and does not need to control the transmitter keying directly.

GSM 06.94 [11] describes the VAD algorithm and GSM 06.73 [5] defines the C code. The verification of compliance to GSM 06.94 [11] is achieved by use of digital test sequences (see GSM 06.74 [6]) applied to the same interface as the test sequences for the speech codec.

8 Adaptive multi-rate speech channel comfort noise insertion

The adaptive multi-rate noise comfort insertion function is described in GSM 06.92 [9].

When switching the transmission on and off during DTX operation, the effect would be a modulation of the background noise at the receiving end, if no precautions were taken. When transmission is on, the background noise is transmitted together with the speech to the receiving end. As the speech burst ends, the connection is off and the perceived noise would drop to a very low level. This step modulation of noise may be perceived as annoying and reduce the intelligibility of speech, if presented to a listener without modification.

This "noise contrast effect" is reduced in the GSM system by inserting an artificial noise, termed comfort noise, at the receiving end when speech is absent.

The comfort noise processes are as follows:

- the evaluation of the acoustic background noise in the transmitter;
- the noise parameter encoding (SID frames) and decoding;
- and the generation of comfort noise in the receiver.

The comfort noise processes and the algorithm for updating the noise parameters during speech pauses are defined in detail in GSM 06.92 [9].

The comfort noise mechanism is based on the adaptive multi-rate speech codec defined in GSM 06.90 [7].

9 Adaptive multi-rate speech channel lost speech frame substitution and muting

The adaptive multi-rate speech frame substitution and muting function is described in GSM 06.91 [8].

In the receiver, frames may be lost due to transmission errors or frame stealing. GSM 06.91 [8] describes the actions to be taken in these cases, both for lost speech frames and for lost SID frames in DTX operation.

In order to mask the effect of an isolated lost frame, the lost speech frame is substituted by a predicted frame based on previous frames. Insertion of silence frames is not allowed. For several subsequent lost frames, a muting technique shall be used to indicate to the listener that transmission has been interrupted.

10 Adaptive multi-rate codec homing

The GSM adaptive multi-rate speech transcoder, VAD, DTX system and comfort noise parts of the functions (see

Figure 1) are defined in bit exact arithmetic. Consequently, they shall react on a given input sequence always with the corresponding bit exact output sequence, provided that the internal state variables are also always exactly in the same state at the beginning of the experiment.

The input test sequences provided in GSM 06.74 [6] shall force the corresponding output test sequences, provided that the tested modules are in their home-state when starting.

The modules may be set into their home states by provoking the appropriate homing -functions.

NOTE: This is normally done during reset (initialisation of the codec).

Special inband signalling frames (encoder-homing-frame and decoder-homing-frame) described in GSM 06.90 [7] have been defined to provoke these homing-functions also in remotely placed modules.

This mechanism is specified to support three main areas:

- type approval of mobile terminal equipment;
- type approval of infrastructure equipment;
- remote control and testing for operation and maintenance.

At the end of the first received homing frame, the audio functions that are defined in a bit exact way shall go into their predefined home states. The output corresponding to the first homing frame is dependent on the codec state when the frame was received. Any consecutive homing frames shall produce corresponding homing frames at the output.

History

Document history		
V7.0.1	July 1999	One-step Approval Procedure OAP 9952: 1999-07-28 to 1999-11-26
V7.0.2	December 1999	Publication