

ETSI EN 300 960 V8.0.1 (2000-11)

European Standard (Telecommunications series)

**Digital cellular telecommunications system (Phase 2+);
Full rate speech;
Processing functions
(GSM 06.01 version 8.0.1 Release 1999)**



GSM®
GLOBAL SYSTEM FOR
MOBILE COMMUNICATIONS

ETSI 

Reference

REN/SMG-110601Q8

Keywords

Digital cellular telecommunications system,
Global System for Mobile communications (GSM)

ETSI

650 Route des Lucioles
F-06921 Sophia Antipolis Cedex - FRANCE

Tel.: +33 4 92 94 42 00 Fax: +33 4 93 65 47 16

Siret N° 348 623 562 00017 - NAF 742 C
Association à but non lucratif enregistrée à la
Sous-Préfecture de Grasse (06) N° 7803/88

Important notice

Individual copies of the present document can be downloaded from:

<http://www.etsi.org>

The present document may be made available in more than one electronic version or in print. In any case of existing or perceived difference in contents between such versions, the reference version is the Portable Document Format (PDF). In case of dispute, the reference shall be the printing on ETSI printers of the PDF version kept on a specific network drive within ETSI Secretariat.

Users of the present document should be aware that the document may be subject to revision or change of status. Information on the current status of this and other ETSI documents is available at <http://www.etsi.org/tb/status/>

If you find errors in the present document, send your comment to:
editor@etsi.fr

Copyright Notification

No part may be reproduced except as authorized by written permission.
The copyright and the foregoing restriction extend to reproduction in all media.

© European Telecommunications Standards Institute 2000.
All rights reserved.

Contents

| | |
|---|-----------|
| Intellectual Property Rights | 4 |
| Foreword | 4 |
| 1 Scope | 5 |
| 2 References..... | 5 |
| 3 Abbreviations | 6 |
| 4 Introduction..... | 6 |
| 5 Full rate speech transcoding (GSM 06.10) | 6 |
| 6 Full rate Discontinuous Transmission (DTX) (GSM 06.31)..... | 6 |
| 7 Full rate Voice Activity Detection (VAD) (GSM 06.32) | 7 |
| 8 Full rate comfort noise insertion (GSM 06.12) | 7 |
| 9 Full rate lost speech frame substitution and muting (GSM 06.11) | 7 |
| 10 Full Rate codec homing (GSM 06.10, optional feature)..... | 8 |
| 11 Speech transmission functions of the half rate traffic channel..... | 8 |
| Annex A (informative): Change Request History | 10 |
| History..... | 11 |

Intellectual Property Rights

IPRs essential or potentially essential to the present document may have been declared to ETSI. The information pertaining to these essential IPRs, if any, is publicly available for **ETSI members and non-members**, and can be found in ETSI SR 000 314: "*Intellectual Property Rights (IPRs); Essential, or potentially Essential, IPRs notified to ETSI in respect of ETSI standards*", which is available from the ETSI Secretariat. Latest updates are available on the ETSI Web server (<http://www.etsi.org/ipr>).

Pursuant to the ETSI IPR Policy, no investigation, including IPR searches, has been carried out by ETSI. No guarantee can be given as to the existence of other IPRs not referenced in ETSI SR 000 314 (or the updates on the ETSI Web server) which are, or may be, or may become, essential to the present document.

Foreword

This European Standard (Telecommunications series) has been produced by ETSI Technical Committee Special Mobile Group (SMG).

The present document describes in general terms the speech processing functions within the digital cellular telecommunications system.

The contents of the present document may be subject to continuing work within SMG and may change following formal SMG approval. Should SMG modify the contents of the present document it will then be re-submitted for formal approval procedures by ETSI with an identifying change of release date and an increase in version number as follows:

Version 8.x.y

where:

- 8 GSM Phase 2+ Release 1999.
- x the second digit is incremented for changes of substance, i.e. technical enhancements, corrections, updates, etc.;
- y the third digit is incremented when editorial only changes have been incorporated in the specification.

| National transposition dates | |
|--|------------------|
| Date of adoption of this EN: | 3 November 2000 |
| Date of latest announcement of this EN (doa): | 28 February 2001 |
| Date of latest publication of new National Standard or endorsement of this EN (dop/e): | 31 August 2001 |
| Date of withdrawal of any conflicting National Standard (dow): | 31 August 2001 |

1 Scope

The present document is an introduction to the 06 series of the GSM technical specifications dealing with the Full rate speech processing functions in the GSM system. A general overview of the speech processing parts is given with reference to the technical specifications where each part is specified in detail.

2 References

The following documents contain provisions which, through reference in this text, constitute provisions of the present document.

- References are either specific (identified by date of publication, edition number, version number, etc.) or non-specific.
- For a specific reference, subsequent revisions do not apply.
- For a non-specific reference, the latest version applies.
- A non-specific reference to an ETS shall also be taken to refer to later versions published as an EN with the same number.
- For this Release 1999 document, references to GSM documents are for Release 1999 versions (version 8.x.y).

- [1] GSM 01.04: "Digital cellular telecommunications system (Phase 2+); Abbreviations and acronyms".
- [2] GSM 03.50: "Digital cellular telecommunications system (Phase 2+); Transmission planning aspects of the speech service in the GSM Public Land Mobile Network (PLMN) system".
- [3] GSM 06.10: "Digital cellular telecommunications system (Phase 2+); Full rate speech; Transcoding".
- [4] GSM 06.11: "Digital cellular telecommunications system (Phase 2+); Full rate speech; Substitution and muting of lost frames for full rate speech channels".
- [5] GSM 06.12: "Digital cellular telecommunications system (Phase 2+); Full rate speech; Comfort noise aspect for full rate speech traffic channels".
- [6] GSM 06.31: "Digital cellular telecommunications system (Phase 2+); Full rate speech; Discontinuous Transmission (DTX) for full rate speech traffic channels".
- [7] GSM 06.32: "Digital cellular telecommunications system (Phase 2+); Voice Activity Detector (VAD) for full rate speech traffic channels".
- [8] GSM 06.02: "Digital cellular telecommunications system (Phase 2+); Half rate speech; Half rate speech processing functions".
- [9] GSM 06.20: "Digital cellular telecommunications system (Phase 2+); Half rate speech; Half rate speech transcoding".
- [10] GSM 06.21: "Digital cellular telecommunications system (Phase 2+); Half rate speech; Substitution and muting of lost frames for half rate speech traffic channels".
- [11] GSM 06.22: "Digital cellular telecommunications system (Phase 2+); Half rate speech; Comfort noise aspects for half rate speech traffic channels".
- [12] GSM 06.41: "Digital cellular telecommunications system (Phase 2+); Half rate speech; Discontinuous Transmission (DTX) for half rate speech traffic channels".
- [13] GSM 06.42: "Digital cellular telecommunications system (Phase 2+); Half rate speech; Voice Activity Detector (VAD) for half rate speech traffic channels".

3 Abbreviations

Abbreviations used in the present document are listed in GSM 01.04 [1].

4 Introduction

Figure 1 presents a reference configuration where the various speech processing functions are identified. In this figure, the relevant technical specifications for each function are also indicated.

In figure 1, the audio parts including analogue to digital and digital to analogue conversion are included to show the complete speech path between the audio input/output in the Mobile Station (MS) and the digital interface to the PSTN. The specification of the audio parts are contained in GSM 03.50 [2] (Transmission plan aspects of the speech service in the GSM PLMN system). These aspects are only considered in the GSM 06-series to the extent that the performance of the audio parts affect the performance of the speech transcoder.

5 Full rate speech transcoding (GSM 06.10)

As shown in figure 1, the speech encoder takes its input as a 13 bit uniform PCM signal either from the audio part of the mobile station or on the network side, from the PSTN via an 8 bit/A-law or μ -law (PCS 1900) to 13 bit uniform PCM conversion. The encoded speech at the output of the speech encoder is delivered to the channel coding function defined in GSM 05.03 to produce an encoded block consisting of 456 bits leading to a gross bit rate of 22,8 kbit/s.

In the receive direction, the inverse operations take place. GSM 06.10 [3] describes the detailed mapping between input blocks of 160 speech samples in 13 bit uniform PCM format to encoded blocks of 260 bits and from encoded blocks of 260 bits to output blocks of 160 reconstructed speech samples. The sampling rate is 8 000 sample/s leading to an average bit rate for the encoded bit stream of 13 kbit/s. The coding scheme is the so-called Regular Pulse Excitation - Long Term prediction - Linear Predictive Coder, here-after referred to as RPE-LTP.

The technical specification describes the codec down to the bit level, thus enabling the verification of compliance to the technical specification to a high degree of confidence by use of a set of digital test sequences. These test sequences are also described and are available on floppy disks.

6 Full rate Discontinuous Transmission (DTX) (GSM 06.31)

During a normal conversation, the participants alternate so that, on the average, each direction of transmission is occupied about 50 % of the time. Discontinuous transmission (DTX) is a mode of operation where the transmitters are switched on only for those frames which contain useful information. This may be done for the following two purposes:

- 1) in the MS, battery life will be prolonged or a smaller battery could be used for a given operational duration;
- 2) the average interference level on the "air" is reduced, leading to better spectrum efficiency.

The overall DTX mechanism is implemented in the DTX handlers (TX and RX) described in GSM 06.31 [6] and requires the following functions which are described in separate technical specifications:

- a Voice Activity Detector on the transmit side;
- evaluation of the background acoustic noise on the transmit side, in order to transmit characteristic parameters to the receive side;
- generation on the receive side of a similar noise, called comfort noise, during periods where the radio transmission is cut.

The transmission of comfort noise information to the receive side is achieved by means of a special frame (Silence descriptor = SID). This frame is transmitted at the end of speech bursts and serves as an end of speech marker for the receive side. In order to update the comfort noise characteristics at the receive side, SID frames are transmitted at regular intervals also during speech pauses. This also serves the purpose of improving the measurement of the radio link quality by the radio subsystem.

For the overall DTX functionality, the DTX handlers interwork via various flags with the Radio Subsystem, which is in control of the actual transmitter keying on the TX side and which performs various pre-processing functions on the RX side. This is also described in GSM 06.31 [6].

A common terminology used throughout the GSM 06-series of technical specifications is also defined in the present document.

7 Full rate Voice Activity Detection (VAD) (GSM 06.32)

The input to the VAD is a set of parameters computed by the full-rate speech encoder defined in GSM 06.10 [3]. The VAD uses this information to decide whether each 20 ms speech coder frame contains speech or not. Note that the VAD flag is an input to TX DTX handler and does not control the transmitter keying directly.

The technical specification describes the VAD algorithm down to the bit level. The conventions used in the bit-exact specification are the same as those used in GSM 06.10 [3]. The verification of compliance to the technical specification is achieved by use of digital test sequences applied to the same interface as the test sequences for the speech codec. These test sequences are also described and are available on floppy disks.

8 Full rate comfort noise insertion (GSM 06.12)

When switching the transmission on and off during DTX operation, the effect would be a modulation of the background noise at the receiving end if no precautions were taken. When transmission is on, the background noise is transmitted together with the speech to the receiving end. As the speech burst ends, the connection is off and the perceived noise would drop to a very low level. This step modulation of noise is perceived as very annoying and may reduce the intelligibility of speech if presented to a listener without modification.

This so-called "noise contrast effect" is reduced in the GSM system by inserting an artificial noise, termed comfort noise, at the receiving end when speech is absent.

GSM 06.12 [5] deals with the detailed aspects of the comfort noise process:

- the evaluation of the acoustic background noise in the transmitter;
- the noise parameter encoding (SID frames) and decoding;
- and the generation of comfort noise in the receiver.

The algorithm for updating the noise parameters during speech pauses is also defined.

The comfort noise mechanism is based on the full rate speech codec defined in GSM 06.10 [3].

9 Full rate lost speech frame substitution and muting (GSM 06.11)

In the receiver, frames may be lost due to transmission errors or frame stealing. GSM 06.11 [4] describes the actions to be taken in these cases, both for lost speech frames and for lost SID-frames in DTX operation.

In order to mask the effect of an isolated lost frame, a scheme is used, where the lost speech frame is substituted by a predicted frame based on previous frames. Insertion of silence frames is not allowed. For several lost frames in a row, some muting technique must be used to indicate to the customer that transmission is interrupted.

10 Full Rate codec homing (GSM 06.10, optional feature)

A codec homing procedure has been introduced to the GSM Full Rate speech codec as an optional feature.

The GSM Full Rate speech transcoder and VAD algorithm (see figure 1) are defined in bit exact arithmetic. Consequently, they shall react on a given input sequence always with the corresponding bit exact output sequence, provided that the internal state variables are also always exactly in the same state at the beginning of the experiment.

The input test sequences provided in GSM 06.10 [3] shall force the corresponding output test sequences, provided that the tested modules are in their home-state when starting.

The modules may be set into their home states by provoking the appropriate homing-functions.

NOTE: This is normally done during reset (initialization of the codec).

Special inband signalling frames (encoder-homing-frame and decoder-homing-frame) also described in GSM 06.10 [3] have been defined to provoke these homing-functions also in remotely placed modules.

This mechanism is specified to support three main areas:

- type approval and laboratory test of mobile terminal equipment;
- type approval and laboratory test of infrastructure equipment;
- remote control and testing for operation and maintenance.

At the end of the first received homing frame, the audio functions that are defined in a bit exact way shall be rendered into their predefined home states. The output corresponding to the first homing frame is dependent on the codec state when the frame was received. Any consecutive homing frames shall produce corresponding homing frames at the output.

11 Speech transmission functions of the half rate traffic channel

The gross bit rate of the half rate speech traffic channel is 11,4 kbit/s. The algorithm for the half rate speech transcoder as well as the associated DTX functions are defined in GSM 06.02 [8], GSM 06.20 [9], GSM 06.21 [10], GSM 06.22 [11], GSM 06.41 [12] and GSM 06.42 [13].

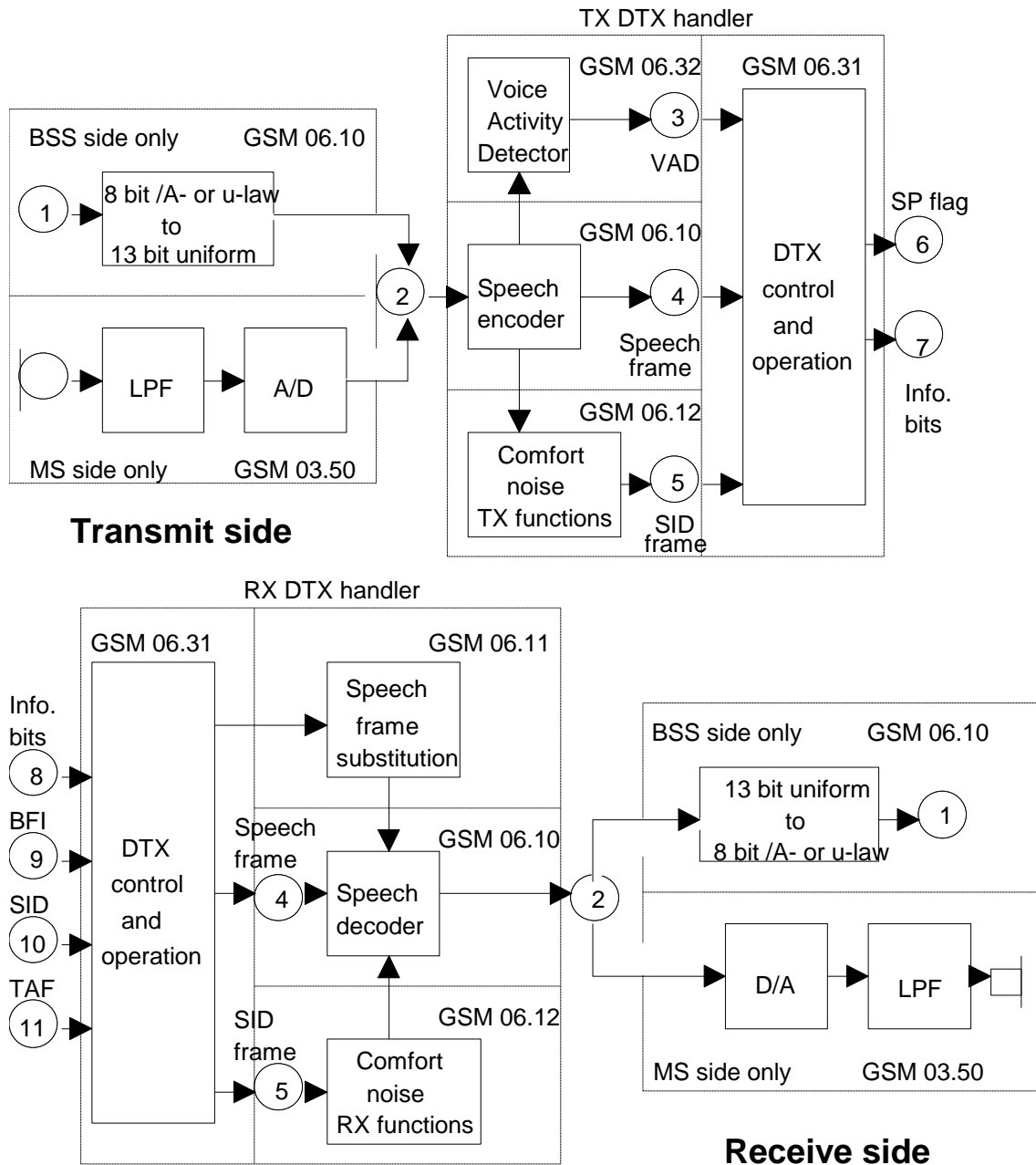

- (1) 8 bit /A- or u-law (PCS 1900) PCM (ITU-T rec G.711)
- (2) 13 bit uniform PCM, 8000 samples/s
- (3) Voice activity flag
- (4) Encoded speech frame, 50 samples/s, 260 bits/frame
- (5) Silence Descriptor (SID) frame, 260 bits/frame
- (6) Speech flag, indicates whether information bits are speech or SID information
- (7) Information bits delivered to the radio subsystem
- (8) Information bits received from the radio subsystem
- (9) Bad Frame Indication (BFI) flag
- (10) Silence Descriptor (SID) flag
- (11) Time Alignment Flag (TAF), marks the position of the SID frame within the SACCH multiframe

Figure 1: Overview of audio processing functions

Annex A (informative): Change Request History

| Change history | | | | | |
|----------------|------------------|--------------|-----------------|-------------|---|
| SMG No. | TDoc. No. | CR. No. | Clause affected | New version | Subject/Comments |
| SMG#07 | | | | 4.0.5 | ETSI Publication |
| SMG#20 | | | | 5.0.1 | Release 1996 version |
| SMG#23 | 97-737 97-741 | A004 A005 | | 5.1.0 | UAP61 comments Introduction of Homing for Full Rate Speech Transcoding |
| SMG#23 | | | | 5.1.1 | ETSI version change |
| SMG#27 | | | | 6.0.0 | Release 1997 version |
| SMG#28 | P-99-136 | A006 | 5 and Figure 1 | 7.0.0 | Addition of mu-law (PCS 1900) |
| | | | | 7.0.2 | Update to Version 7.0.2 for Publication |
| SMG#31 | | | | 8.0.0 | Version for Release 1999 |
| | | | | 8.0.1 | Update to Version 8.0.1 for Publication |

History

| Document history | | |
|-------------------------|---------------|--|
| V8.0.0 | July 2000 | One-step Approval Procedure OAP 20001103: 2000-07-05 to 2000-11-03 |
| V8.0.1 | November 2000 | Publication |
| | | |
| | | |
| | | |