

3GPP TS 05.08 V8.23.0 (2005-11)

Technical Specification

3rd Generation Partnership Project; Technical Specification Group GSM/EDGE Radio Access Network; Radio subsystem link control (Release 1999)



The present document has been developed within the 3rd Generation Partnership Project (3GPP™) and may be further elaborated for the purposes of 3GPP. The present document has not been subject to any approval process by the 3GPP Organizational Partners and shall not be implemented. This Specification is provided for future development work within 3GPP only. The Organizational Partners accept no liability for any use of this Specification. Specifications and reports for implementation of the 3GPP™ system should be obtained via the 3GPP Organizational Partners' Publications Offices.

Keywords

GSM, radio

3GPP

Postal address

3GPP support office address

650 Route des Lucioles - Sophia Antipolis
Valbonne - FRANCE
Tel.: +33 4 92 94 42 00 Fax: +33 4 93 65 47 16

Internet

<http://www.3gpp.org>

Copyright Notification

No part may be reproduced except as authorised by written permission.
The copyright and the foregoing restrictions extend to reproduction in all media.

© 2005 3GPP Organizational Partners (ARIB, ATIS, CCSA, ETSI, TTA, TTC).
All rights reserved.

3GPP

Contents

Foreword.....	7
1 Scope.....	8
1.1 References.....	8
1.2 Abbreviations.....	9
2 General.....	9
3 Handover.....	11
3.1 Overall process.....	11
3.2 MS measurement procedure.....	11
3.3 BSS measurement procedure.....	11
3.4 Strategy.....	11
4 RF power control.....	12
4.1 Overall process.....	12
4.2 MS implementation.....	12
4.3 MS power control range.....	12
4.4 BSS implementation.....	13
4.5 BSS power control range.....	13
4.6 Strategy.....	13
4.7 Timing.....	13
4.8 Dedicated channels used for a voice group call or voice broadcast.....	14
5 Radio link failure.....	14
5.1 Criterion.....	14
5.2 MS procedure.....	15
5.3 BSS procedure.....	15
6 Idle mode tasks.....	15
6.1 Introduction.....	15
6.2 Measurements for normal cell selection.....	16
6.3 Measurements for stored list cell selection.....	16
6.4 Criteria for cell selection and reselection.....	17
6.5 Downlink signalling failure.....	18
6.6 Measurements for Cell Reselection.....	19
6.6.1 Monitoring of received signal level and BCCH data.....	19
6.6.2 Path loss criteria and timings for cell re-selection.....	20
6.6.3 Cell reselection algorithm for SoLSA.....	20
6.6.4 Measurements on cells of other radio access technologies.....	21
6.6.5 Algorithm for cell re-selection from GSM to UTRAN.....	22
6.7 Release of TCH and SDCCH.....	23
6.7.1 Normal case.....	23
6.7.2 Call re-establishment.....	24
6.8 Abnormal cases and emergency calls.....	24
7 Network pre-requisites.....	25
7.1 BCCH carriers.....	25
7.2 Identification of surrounding BSS for handover measurements.....	25
7.3 Handover measurements on other radio access technologies.....	27
8 Radio link measurements.....	28
8.1 Signal level.....	28
8.1.1 General.....	28
8.1.2 Physical parameter.....	28
8.1.3 Statistical parameters.....	29
8.1.4 Range of parameter.....	30
8.1.5 Measurement quantity for other radio access technologies.....	30
8.1.5.1 UTRAN FDD.....	30
8.1.5.2 UTRAN TDD.....	30
8.1.5.3 cdma2000.....	30

8.2	Signal quality	30
8.2.1	General.....	30
8.2.2	Physical parameter.....	31
8.2.3	Statistical parameters.....	31
8.2.4	Range of parameter RXQUAL.....	32
8.2.5	Range of parameters MEAN_BEP and CV_BEP.....	33
8.3	Aspects of discontinuous transmission (DTX)	35
8.4	Measurement reporting	35
8.4.1	Measurement reporting for the MS on a TCH.....	35
8.4.1.1	Measurement reporting for the MS on an E-TCH in FPC mode.....	36
8.4.2	Measurement reporting for the MS on a SDCCH.....	37
8.4.3	Additional cell reporting requirements for multi band MS.....	37
8.4.4	Common aspects for the MS on a TCH or a SDCCH.....	38
8.4.5	Measurement reporting for the BSS.....	38
8.4.6	Extended measurement reporting.....	38
8.4.7	Additional cell reporting requirements for multi-RAT MS.....	39
8.4.8	Enhanced Measurement Reporting.....	39
8.4.8.1	Reporting Priority.....	40
8.4.8.2	Measurement Reporting.....	40
8.5	Absolute MS-BTS distance.....	41
8.5.1	General.....	41
8.5.2	Physical parameter.....	41
9	Control parameters.....	42
10	GPRS mode tasks	45
10.1	Cell Re-selection	45
10.1.1	Monitoring the received signal level and PBCCH	46
10.1.1.1	Packet idle mode.....	46
10.1.1.2	Packet transfer mode.....	46
10.1.1.3	Monitoring cells of other radio access technologies	48
10.1.2	Cell Re-selection Criteria	49
10.1.3	Cell Re-selection Algorithm	50
10.1.3.1	Abnormal cell reselection	51
10.1.3.2	Algorithm for cell re-selection from GSM to UTRAN.....	51
10.1.4	Network controlled Cell re-selection.....	52
10.1.4.1	Measurement reporting.....	53
10.1.4.2	Cell re-selection command	55
10.1.4.3	Exceptional cases.....	55
10.1.5	Extended Measurement reporting	55
10.2	RF Power Control	56
10.2.1	MS output power.....	57
10.2.2	BTS output power.....	57
10.2.3	Measurements at MS side.....	59
10.2.3.1	Deriving the C value	59
10.2.3.1.1	Packet idle mode.....	59
10.2.3.1.2	Packet transfer mode.....	60
10.2.3.2	Derivation of Channel Quality Report.....	61
10.2.3.2.1	Packet transfer mode.....	61
10.2.3.2.2	Packet idle mode.....	63
10.2.3.2.3	Measurement reporting.....	64
10.2.4	Measurements at BSS side	64
10.3	Measurement requirements	64
10.4	Control parameters	65
11	CTS mode tasks.....	69
11.1	CTS idle mode tasks	69
11.1.1	CTS cell selection	69
11.1.1.1	Synchronization and measurements for CTS cell selection	69
11.1.1.2	Initial synchronization of CTS-MS	69
11.1.2	Criterion for CTS cell selection.....	70
11.1.3	Monitoring of CTSBCH and CTSPCH.....	70
11.1.3.1	Monitoring of received signal level.....	70
11.1.3.2	Downlink beacon failure	70

11.1.3.3	Downlink paging failure.....	70
11.1.4	Procedures with reporting to the CTS-FP.....	71
11.1.4.1	AFA monitoring.....	71
11.1.4.2	BCCH detection.....	71
11.1.4.3	Observed Frequency Offset (OFO) measurement	71
11.2	Intra-cell handover.....	72
11.2.1	Overall process.....	72
11.2.2	CTS-MS measurement procedure.....	72
11.2.3	CTS-FP measurement procedure	72
11.2.4	Strategy.....	72
11.3	RF power control.....	72
11.3.1	Overall process.....	72
11.3.2	CTS-MS implementation.....	72
11.3.3	CTS-MS power control range.....	73
11.3.4	CTS-FP implementation	73
11.3.5	CTS-FP power control range	73
11.3.6	Strategy.....	73
11.3.7	Timing.....	73
11.4	Radio link failure	74
11.4.1	Criterion.....	74
11.4.2	CTS-MS procedure.....	74
11.4.3	CTS-FP procedure	74
11.5	Radio link measurements.....	74
11.5.1	Signal strength.....	74
11.5.1.1	General	74
11.5.1.2	Physical parameter	74
11.5.1.3	Statistical parameters	75
11.5.1.4	Range of parameter	75
11.5.2	Signal quality	75
11.5.2.1	General	75
11.5.2.2	Physical parameter	75
11.5.2.3	Statistical parameters	75
11.5.2.4	Range of parameter	75
11.5.3	Aspects of discontinuous transmission (DTX).....	75
11.5.4	Measurement reporting for the CTS-MS on a TCH	75
11.6	Control of CTS-FP service range	76
11.7	Control parameters	76
12	COMPACT Mode Tasks.....	78
12.1	Introduction.....	78
12.2	Network Pre-requisites.....	78
12.2.1	CPBCCH carriers.....	78
12.3	COMPACT Idle Mode Tasks.....	78
12.3.1	Introduction.....	78
12.3.2	Measurements for COMPACT Cell Selection.....	78
12.3.3	Measurements for COMPACT Stored List Cell Selection	79
12.3.4	Criteria for COMPACT Cell Selection	79
12.3.5	Downlink Signalling Failure.....	79
12.4	COMPACT Cell Reselection	79
12.4.1	Monitoring the received signal level and CPBCCH data.....	80
12.4.1.1	Packet idle mode.....	80
12.4.1.2	Packet transfer mode.....	80
12.4.2	COMPACT cell reselection criteria.....	81
12.4.3	COMPACT cell reselection algorithm.....	81
12.4.4	Network controlled Cell reselection	81
12.4.5	COMPACT cell reselection measurement opportunities.....	81

Annex A (informative):	Definition of a basic GSM or DCS 1 800 handover and RF power control algorithm.....	82
A.1	Scope.....	82
A.2	Functional requirement.....	82
A.3	BSS pre-processing and threshold comparisons.....	82
A.3.1	Measurement averaging process.....	83
A.3.2	Threshold comparison process.....	84
A.3.2.1	RF power control process.....	84
A.3.2.2	Handover Process.....	85
A.4	BSS decision algorithm.....	86
A.4.1	Internal intracell handover according to radio criteria: (Interference problems).....	86
A.4.2	Internal handover according to other criteria.....	87
A.4.3	General considerations.....	87
A.5	Channel allocation.....	87
A.6	Handover decision algorithm in the MSC.....	87
Annex B (informative):	Power Control Procedures.....	90
B.1	Open loop control.....	90
B.2	Closed loop control.....	90
B.3	Quality based control.....	91
B.4	BTS power control.....	91
B.5	Example.....	92
B.6	Interworking between normal and fast power control for ECSD.....	93
Annex C (informative):	Example Interference Measurement Algorithm.....	94
Annex D (informative):	Example Selection of Modulation and Coding Schemes based on Link Quality Reports.....	95
Annex E (informative):	Change history.....	96

Foreword

This Technical Specification has been produced by the 3rd Generation Partnership Project (3GPP).

The contents of the present document are subject to continuing work within the TSG and may change following formal TSG approval. Should the TSG modify the contents of the present document, it will be re-released by the TSG with an identifying change of release date and an increase in version number as follows:

Version x.y.z

where:

x the first digit:

1 presented to TSG for information;

2 presented to TSG for approval;

3 or greater indicates TSG approved document under change control.

y the second digit is incremented for all changes of substance, i.e. technical enhancements, corrections, updates, etc.

z the third digit is incremented when editorial only changes have been incorporated in the document.

1 Scope

The present document specifies the Radio sub-system link control implemented in the Mobile Station (MS), Base Station System (BSS) and Mobile Switching Centre (MSC) of the digital cellular telecommunications systems GSM.

Unless otherwise specified, references to GSM also include operation in any band.

1.1 References

The following documents contain provisions which, through reference in this text, constitute provisions of the present document.

- References are either specific (identified by date of publication, edition number, version number, etc.) or non-specific.
- For a specific reference, subsequent revisions do not apply.
- For a non-specific reference, the latest version applies. In the case of a reference to a 3GPP document (including a GSM document), a non-specific reference implicitly refers to the latest version of that document *in the same Release as the present document*.

- [1] 3GPP TR 01.04: "Digital cellular telecommunications system (Phase 2+); Abbreviations and acronyms".
- [2] 3GPP TS 03.03: "Digital cellular telecommunications system (Phase 2+); Numbering, addressing and identification".
- [3] 3GPP TS 03.09: "Digital cellular telecommunications system (Phase 2+); Handover procedures".
- [4] 3GPP TS 03.22: "Digital cellular telecommunications system (Phase 2+); Functions related to Mobile Station (MS) in idle mode and group receive mode".
- [5] 3GPP TS 04.04: "Digital cellular telecommunications system (Phase 2+); Layer 1; General requirements".
- [6] 3GPP TS 04.06: "Digital cellular telecommunications system (Phase 2+); Mobile Station - Base Station System (MS - BSS) interface; Data Link (DL) layer specification".
- [7] 3GPP TS 04.18: "Digital cellular telecommunications system (Phase 2+); Mobile radio interface layer 3 specification; Radio Resource Control Protocol".
- [8] 3GPP TS 05.02: "Digital cellular telecommunications system (Phase 2+); Multiplexing and multiple access on the radio path".
- [9] 3GPP TS 05.05: "Digital cellular telecommunications system (Phase 2+); Radio transmission and reception".
- [10] 3GPP TS 05.10: "Digital cellular telecommunications system (Phase 2+); Radio subsystem synchronization".
- [11] 3GPP TS 06.11: "Digital cellular telecommunications system; Full rate speech; Substitution and muting of lost frames for full rate speech channels".
- [12] 3GPP TS 08.08: "Digital cellular telecommunications system (Phase 2+); Mobile-services Switching Centre - Base Station System (MSC - BSS) interface, Layer 3 specification".
- [13] 3GPP TS 08.58: "Digital cellular telecommunications system (Phase 2+); Base Station Controller - Base Transceiver Station (BSC - BTS) interface; Layer 3 specification".
- [14] 3GPP TS 11.10: "Digital cellular telecommunications system (Phase 2+); Mobile Station (MS) conformity specification".

- [15] 3GPP TS 03.64: "Digital cellular telecommunications system (Phase 2+); General Packet Radio Service (GPRS); Overall description of the GPRS Radio Interface; Stage 2".
- [16] 3GPP TS 03.52: "Digital cellular telecommunications system (Phase 2+); GSM Cordless Telephony System (CTS), Phase 1; Lower layers of the CTS Radio Interface; Stage 2".
- [17] 3GPP TS 04.56: "Digital cellular telecommunications system (Phase 2+); GSM Cordless Telephony System (CTS), Phase 1; CTS radio interface layer 3 specification".
- [18] 3GPP TS 05.56: "Digital cellular telecommunications system (Phase 2+); GSM Cordless Telephony System (CTS), Phase 1; CTS-FP radio subsystem".
- [19] TIA/EIA/IS-2000-5-A: "Upper Layer (Layer 3) Signaling Standard for cdma2000 Spread Spectrum Systems".
- [20] TIA/EIA/IS-833: "Multi-Carrier Specification for Spread Spectrum Systems on GSM MAP (MC-MAP) (Lower Layers Air Interface)".

1.2 Abbreviations

Abbreviations used in the present document are listed in 3GPP TR 01.04.

2 General

The radio sub-system link control aspects that are addressed are as follows:

- Handover;
- RF Power control, including fast power control for ECSD;
- Radio link Failure;
- Cell selection and re-selection in Idle mode, in Group Receive mode and in GPRS mode (see 3GPP TS 03.22);
- CTS mode tasks.

Handover is required to maintain a call in progress as a MS engaged in a point-to-point call or with access to the uplink of a channel used for a voice group call passes from one cell coverage area to another and may also be employed to meet network management requirements, e.g. relief of congestion.

Handover may occur during a call from one TCH or multiple TCHs (in the case of multislot configuration) to another TCH or multiple TCHs. It may also occur from DCCH to DCCH or from DCCH to one or multiple TCH(s), e.g. during the initial signalling period at call set-up.

The handover may be either from channel(s) on one cell to other channel(s) on a surrounding cell, or between channels on the same cell which are carried on the same frequency band. Examples are given of handover strategies, however, these will be determined in detail by the network operator.

For a multiband MS, specified in 3GPP TS 02.06, the handover described is also allowed between any channels on different cells which are carried on different frequency bands, e.g. between a GSM 900/TCH and a DCS 1800/TCH. Handover between two co-located cells, carried on different frequency bands, is considered as inter-cell handover irrespective of the handover procedures used.

For a multi-RAT MS, i.e. an MS supporting multiple radio access technologies, handover is allowed between GSM and other radio access technologies.

NOTE: At handover, the MS will normally not be able to verify the PLMN of the target cell and will thus assume that the same system information apply after the handover unless the network provides new system information.

Adaptive control of the RF transmit power from an MS and optionally from the BSS is implemented in order to optimize the uplink and downlink performance and minimize the effects of co-channel interference in the system.

The criteria for determining radio link failure are specified in order to ensure that calls which fail either from loss of radio coverage or unacceptable interference are satisfactorily handled by the network. Radio link failure may result in either re-establishment or release of the call in progress. For channels used for a voice group call, a radio uplink failure results in the freeing up of the uplink.

Procedures for cell selection and re-selection whilst in Idle mode (i.e. not actively processing a call), are specified in order to ensure that a mobile is camped on a cell with which it can reliably communicate on both the radio uplink and downlink. The operations of an MS in Idle Mode are specified in 3GPP TS 03.22.

Cell re-selection is also performed by the MS when attached to GPRS, except when the MS simultaneously has a circuit switched connection. Optional procedures are also specified for network controlled cell re-selection for GPRS. Cell re-selection for GPRS is defined in subclause 10.1.

For a multi-RAT MS, cell selection and re-selection is allowed between GSM and other radio access technologies.

An MS listening to a voice group call or a voice broadcast use cell re-selection procedures to change cell. This may be supported by a list of cells carrying the voice group or voice broadcast call downlink, provided to the MS by the network. The operations of an MS in Group Receive Mode are specified in 3GPP TS 03.22.

Information signalled between the MS and BSS is summarized in tables 1, 2 and 3. A full specification of the Layer 1 header is given in 3GPP TS 04.04, and of the Layer 3 fields in 3GPP TS 04.18 and 3GPP TS 04.60.

For CTS, information signalled between the CTS-MS and CTS-FP is summarized in tables 4, 5 and 6. A full specification of the CTS Layer 3 fields is given in 3GPP TS 04.56.

For COMPACT, specific procedures are defined in clause 12.

3 Handover

3.1 Overall process

The overall handover process is implemented in the MS, BSS and MSC. Measurement of radio subsystem downlink performance and signal levels received from surrounding cells, is made in the MS. These measurements are signalled to the BSS for assessment. The BSS measures the uplink performance for the MS being served and also assesses the signal level of interference on its idle traffic channels. Initial assessment of the measurements in conjunction with defined thresholds and handover strategy may be performed in the BSS. Assessment requiring measurement results from other BTS or other information resident in the MSC, may be performed in the MSC.

3GPP TS 03.09 describes the handover procedures to be used in PLMNs.

3.2 MS measurement procedure

A procedure shall be implemented in the MS by which it monitors the downlink RX signal level and quality from its serving cell and the downlink RX signal level and BSIC of surrounding BTS. The method of identification of surrounding BTS is described in subclause 7.2. The requirements for the MS measurements are given in subclause 8.1.

3.3 BSS measurement procedure

A procedure shall be implemented in the BSS by which it monitors the uplink RX signal level and quality from each MS being served by the cell. In the case of a multislot configuration the evaluation shall be performed on a timeslot per timeslot basis. A procedure shall be implemented by which the BSS monitors the levels of interference on its idle traffic channels.

3.4 Strategy

The handover strategy employed by the network for radio link control determines the handover decision that will be made based on the measurement results reported by the MS/BSS and various parameters set for each cell. Network directed handover may also occur for reasons other than radio link control, e.g. to control traffic distribution between cells. The exact handover strategies will be determined by the network operator, a detailed example of a basic overall algorithm appears in annex A. Possible types of handover are as follows:

Inter-cell handover:

Intercell handover from the serving cell to a surrounding cell will normally occur either when the handover measurements show low RXLEV and/or RXQUAL on the current serving cell and a better RXLEV available from a surrounding cell, or when a surrounding cell allows communication with a lower TX power level. This typically indicates that an MS is on the border of the cell area.

Intercell handover may also occur from the DCCH on the serving cell to a TCH or multislot configuration on another cell during call establishment. This may be used as a means of providing successful call establishment when no suitable TCH resource is available on the current serving cell.

Inter-cell handover between cells using different frequency bands is allowed for a multi band MS.

Inter-cell handover between cells using different radio access technologies is allowed for a multi-RAT MS.

Intra-cell handover:

Intra-cell handover from one channel/timeslot configuration in the serving cell to another channel/timeslot configuration in the same cell will normally be performed if the handover measurements show a low RXQUAL, but a high RXLEV on the serving cell. This indicates a degradation of quality caused by interference even though the MS is situated within the serving cell. The intra-cell handover should provide a channel with a lower level of interference. Intra-cell handover can occur either to a timeslot on a new carrier or to a different timeslot on the same carrier. Similarly, intra-cell handover may occur between different multislot configurations in the same cell. These multislot configurations may comprise different number of timeslots and may partly overlap.

Intra-cell handover from one of the bands of operation to another one is allowed for a multiband MS.

3GPP TS 08.08 defines the causes for handover that may be signalled from BSS to MSC.

4 RF power control

4.1 Overall process

RF power control is employed to minimize the transmit power required by MS or BSS whilst maintaining the quality of the radio links. By minimizing the transmit power levels, interference to co-channel users is reduced.

4.2 MS implementation

RF power control shall be implemented in the MS.

The power control level to be employed by the MS on each uplink channel, except PDCH, is indicated by means of the power control information sent either in the layer 1 header of each SACCH message block (see 3GPP TS 04.04) on the corresponding downlink channel, or in a dedicated signalling block (see 3GPP TS 04.18). Power control for PDCH is defined in subclause 10.2.

The MS shall employ the most recently commanded power control level appropriate to each channel for all transmitted bursts on either a TCH (including handover access burst), FACCH, SACCH or SDCCH.

The MS shall confirm the power control level that it is currently employing in the SACCH L1 header on each uplink channel. The indicated value shall be the power control level actually used by the mobile for the last burst of the previous SACCH period.

When on an E-TCH, the MS shall, if so indicated by the BSS in the SACCH L1 header (see 3GPP TS 04.04) or Assignment command (see 3GPP TS 04.18), use FPC (fast power control). The MS shall employ the most recently commanded fast power control level on each uplink E-TCH channel. The power control level to be employed by the MS is indicated by means of the power control information sent via E-IACCH once every FPC reporting period (see subclause 4.7). If FPC is in use, the MS shall report, in the SACCH L1 header, the power control level used at the end of the normal power control reporting period.

When on an E-TCH using 8 PSK for the uplink, the MS shall use the E-IACCH in the uplink for fast measurement reporting.

NOTE: The term "normal power control" is used in this specification only for clarification and is otherwise only referred to as "power control".

In case of a multislot configuration, each bi-directional channel shall be power controlled individually by the corresponding SACCH or E-IACCH, whichever is applicable. Power control information on downlink unidirectional channels shall be neglected.

When accessing a cell on the RACH (random access) and before receiving the first power command during a communication on a DCCH or TCH (after an IMMEDIATE ASSIGNMENT), all MS except class 3 DCS 1 800 MS shall use the power level defined by the MS_TXPWR_MAX_CCH parameter broadcast on the BCCH of the cell. The class 3 DCS 1 800 MS shall use the power level defined by MS_TXPWR_MAX_CCH plus the value POWER_OFFSET also broadcast on the BCCH of the cell.

If a power control level defined in 3GPP TS 05.05 is received but the level is not supported by the MS, the MS shall use the supported output power which is closest to the output power indicated by the received power control level.

4.3 MS power control range

The range over which an MS shall be capable of varying its RF output power shall be from its maximum output down to its minimum, in steps of nominally 2 dB.

3GPP TS 05.05 gives a detailed definition of the RF power level step size and tolerances.

The fast power control scheme for ECSD is based on differential control to adjust the employed RF power level. The possible DL power control commands are listed in the following table.

Codeword	Power control command
0	Not used
1	Increase output power by four power control levels
2	Increase output power by three power control levels
3	Increase output power by two power control levels
4	Increase output power by one power control level
5	No output power level change
6	Decrease output power by one power control level
7	Decrease output power by two power control levels

If a power control command is received but the requested output power is not supported by the MS, the MS shall use the supported output power which is closest to the requested output power.

4.4 BSS implementation

RF power control, including fast power control for ECSD, may optionally be implemented in the BSS.

4.5 BSS power control range

The range over which the BSS shall be capable of reducing its RF output power from its maximum level shall be nominally 30 dB, in 15 steps of nominally 2 dB.

3GPP TS 05.05 gives a detailed definition of the RF power level step size and tolerances.

4.6 Strategy

The RF power control strategy employed by the network determines the ordered power level that is signalled to the MS, and the power level that is employed by the BSS.

The power level to be employed in each case will be based on the measurement results reported by the MS/BTS and various parameters set for each cell. The exact strategies will be determined by the network operator. A detailed example of a basic algorithm appears in annex A.

4.7 Timing

Upon receipt of a command from an SACCH to change its power level on the corresponding uplink channel, the MS shall change to the new level at a rate of one nominal 2 dB power control step every 60 ms (13 TDMA frames), i.e. a range change of 15 steps should take about 900 ms. The change shall commence at the first TDMA frame belonging to the next reporting period (as specified in subclause 8.4). The MS shall change the power one nominal 2 dB step at a time, at a rate of one step every 60 ms following the initial change, irrespective of whether actual transmission takes place or not.

In case of channel change, except for multislot configuration change, the commanded power control level shall be applied on each new channel immediately. The multislot configuration change message does not command the MS to use new power control levels. For those time slots not used by the MS before the multislot configuration change procedure, the MS shall use the power control level used on the main channel before the multislot configuration change.

Switching between the normal power control mechanism and FPC shall be done if FPC is enabled or disabled via signalling in the SACCH L1 header. The respective power control mechanism to be used shall then be active as from the first TDMA frame belonging to the next reporting period (see subclause 8.4). The initial power control level to be used by the MS immediately after switching shall, in both cases, be the level last commanded by the normal power control mechanism.

The basic timing cycle for the fast power control mechanism is the FPC reporting period of length 4 TDMA frames, which is mapped into the 26-multiframe according to the following figure.

FN:	0	1	2	3	4	5	6	7	8	9	10	11	12	13	14	15	16	17	18	19	20	21	22	23	24	25
RP:	0	0	0	0	1	1	1	1	2	2	2	2	S	3	3	3	3	4	4	4	4	5	5	5	5	I

FN = TDMA Frame no modulo 26

RP = FPC reporting period number

DL measurements made during RP(n) shall be reported to the network during the next occurrence of RP((n+2) mod 6). Power control commands received from the network during RP(n) are effectuated on the corresponding UL channel during the next occurrence of RP((n+1) mod 6).

4.8 Dedicated channels used for a voice group call or voice broadcast

The network shall not allocate the uplink of the channel used for a voice group call to more than one MS. If marked busy, no other MS shall transmit on the channel. This marking is indicated by the network, as defined in 3GPP TS 03.68 and 04.18. Any MS allocated the uplink of a channel used for a voice group call shall only transmit if the uplink is marked busy, and shall stop using the uplink if it happens to become marked free. An MS not allocated the uplink may perform a random access procedure on the uplink to gain access to talk, only if the uplink is marked as free.

On a channel used during a voice group call, the uplink power control shall only apply to the MS currently allocated that uplink, and the MS power control level ordered by the network shall be ignored by all other MSs listening to the downlink.

When performing a random access on a cell to gain access to the uplink of a channel used for a voice group call, until receiving the first dedicated power command from the network, the MS shall use the last received power level command as defined by the MS_TXPWR_MAX_CCH parameter broadcast on the BCCH of the cell, or if MS_TXPWR_MAX_CCH corresponds to a power control level not supported by the MS as defined by its power class in 3GPP TS 05.05, the MS shall act as though the closest supported power control level had been broadcast.

RF downlink power control will normally not be applied on channels used for a voice group call or voice broadcast.

5 Radio link failure

5.1 Criterion

The criterion for determining Radio Link Failure in the MS shall be based on the success rate of decoding messages on the downlink SACCH. For a circuit switched multislotted configuration, only the main SACCHs shall be used for determining Radio Link Failure.

For GPRS, Radio Link Failure is determined by the RLC/MAC protocol (see 3GPP TS 04.60).

5.2 MS procedure

The aim of determining radio link failure in the MS is to ensure that calls with unacceptable voice/data quality, which cannot be improved either by RF power control or handover, are either re-established or released in a defined manner. In general the parameters that control the forced release should be set such that the forced release will not normally occur until the call has degraded to a quality below that at which the majority of subscribers would have manually released. This ensures that, for example, a call on the edge of a radio coverage area, although of bad quality, can usually be completed if the subscriber wishes.

The radio link failure criterion is based on the radio link counter *S*. If the MS is unable to decode a SACCH message (BFI = 1), *S* is decreased by 1. In the case of a successful reception of a SACCH message (BFI = 0) *S* is increased by 2. In any case *S* shall not exceed the value of RADIO_LINK_TIMEOUT. If *S* reaches 0 a radio link failure shall be declared. The action to be taken is specified in 3GPP TS 04.18. The RADIO_LINK_TIMEOUT parameter is transmitted by each BSS in the BCCH data (see table 1).

The MS shall continue transmitting as normal on the uplink until *S* reaches 0.

The algorithm shall start after the assignment of a dedicated channel and *S* shall be initialized to RADIO_LINK_TIMEOUT.

The detailed operation shall be as follows:

- the radio link time-out algorithm shall be stopped at the reception of a channel change command;
- (re-)initialization and start of the algorithm shall be done whenever the MS switches to a new channel (this includes the old channel in assignment and handover failure cases), at the latest when the main signalling link (see 3GPP TS 04.18) has been established;
- the RADIO_LINK_TIMEOUT value used at (re-)initialization shall be that used on the previous channel (in the Immediate Assignment case the value received on the BCCH), or the value received on SACCH if the MS has received a RADIO_LINK_TIMEOUT value on the new channel before the initialization;
- if the first RADIO_LINK_TIMEOUT value on the SACCH is received on the new channel after the initialization, the counter shall be re-initialized with the new value.

An MS listening to a voice group call or a voice broadcast, upon a downlink radio link failure shall return to idle mode and perform cell re-selection.

5.3 BSS procedure

The criteria for determining radio link failure in the BSS should be based upon either the error rate on the uplink SACCH(s) or on RXLEV/RXQUAL measurements of the MS. The exact criteria to be employed shall be determined by the network operator.

For channels used for a voice group call, the radio link failure procedures in the BSS shall be reset upon the re-allocation of the uplink to another MS. Upon an uplink radio failure, the network shall mark it as free, see subclause 4.8.

Whenever the uplink is not used, and for channels used for voice broadcast, the BSS radio link failure procedures shall not apply on that channel.

6 Idle mode tasks

6.1 Introduction

Whilst in idle mode, an MS shall implement the cell selection and re-selection procedures described in 3GPP TS 03.22. These procedures make use of measurements and sub-procedures described in this subclause.

The procedures ensure that the MS is camped on a cell from which it can reliably decode downlink data and with which it has a high probability of communications on the uplink. Once the MS is camped on a cell, access to the network is allowed.

This clause makes use of terms defined in 3GPP TS 03.22.

The MS shall not use the discontinuous reception (DRX) mode of operation (i.e. powering itself down when it is not expecting paging messages from the network) while performing the cell selection algorithm defined in 3GPP TS 03.22. However use of powering down is permitted at all other times in idle mode.

For the purpose of cell selection and reselection, the MS shall be capable of detecting and synchronizing to a BCCH carrier and read the BCCH data at reference sensitivity level and reference interference levels as specified in 3GPP TS 05.05. An MS in idle mode shall always fulfil the performance requirement specified in 3GPP TS 05.05 at levels down to reference sensitivity level or reference interference level. The allowed error rates (see 3GPP TS 05.05) might impact the cell selection and reselection procedure, e.g. trigger cell reselection. Moreover, one consequence of the allowed error rates is that in the case of no frequency hopping and a TU3 (TU6 for GSM 400, TU1.5 for DCS 1 800 and PCS 1 900) propagation profile it can not be expected that an MS will respond to paging unless the received signal level is 2 dB higher than the specified reference level.

For the purposes of cell selection and reselection, the MS is required to maintain an average of received signal levels for all monitored frequencies. These quantities termed the "received level averages" (RLA_C), shall be unweighted averages of the received signal levels measured in dBm. The accuracy of the received signal level measurements for idle mode tasks shall be the same as for radio link measurements (see subclause 8.1.2).

The times given in subclauses 6.2, 6.3 and 6.6 refer to internal processes in the MS required to ensure that the MS camps as quickly as possible to the most appropriate cell.

For the cell selection, the MS shall be able to select the correct (fourth strongest) cell and be able to respond to paging on that cell within 30 seconds of switch on, when the three strongest cells are not suitable. This assumes a valid SIM with PIN disabled and ideal radio conditions. This requirement is not applicable for multi-RAT mobile stations.

The tolerance on all the timing requirements in clause 6 is $\pm 10\%$, except for PENALTY_TIME where it is ± 2 s.

6.2 Measurements for normal cell selection

The measurements of this clause shall be performed by an MS which has no prior knowledge of which RF channels are BCCH carriers.

The MS shall search all RF channels within its bands of operation, take readings of received RF signal level on each RF channel, and calculate the RLA_C for each. The averaging is based on at least five measurement samples per RF carrier spread over 3 to 5 s, the measurement samples from the different RF carriers being spread evenly during this period.

A multi band MS shall search all channels within its bands of operation as specified above. The number of channels searched will be the sum of channels on each band of operation.

BCCH carriers can be identified by, for example, searching for frequency correction bursts. On finding a BCCH carrier, the MS shall attempt to synchronize to it and read the BCCH data.

The maximum time allowed for synchronization to a BCCH carrier is 0.5 s, and the maximum time allowed to read the BCCH data, when being synchronized to a BCCH carrier, is 1.9 s or equal to the scheduling period for the BCCH data, whichever is greater (see 3GPP TS 05.02). The MS is allowed to camp on a cell and access the cell after decoding all relevant BCCH data.

6.3 Measurements for stored list cell selection

The MS may include optional storage of BCCH carrier information when switched off as detailed in 3GPP TS 03.22. For example, the MS may store the BCCH carriers in use by the PLMN selected when it was last active in network. The BCCH list may include BCCH carriers from more than one band in a multi band operation PLMN. A MS may also store BCCH carriers for more than one PLMN which it has selected previously (e.g. at national borders or when more than one PLMN serves a country), in which case the BCCH carrier lists must be kept quite separate.

The stored BCCH carrier information used by the MS may be derived by a variety of different methods. The MS may use the BA_RANGE information element, which, if transmitted in the channel release message (see 3GPP TS 04.18), indicates ranges of carriers which include the BCCH carriers in use over a wide area or even the whole

PLMN. It should be noted that the BA(BCCH) list might only contain carriers in use in the vicinity of the cell on which it was broadcast, and therefore might not be appropriate if the MS is switched off and moved to a new location.

The BA_RANGE information element contains the Number of Ranges parameter (defined as NR) as well as NR sets of parameters RANGE_i_LOWER and RANGE_i_HIGHER. The MS should interpret these to mean that all the BCCH carriers of the network have ARFCNs in the following ranges:

Range1 = ARFCN(RANGE1_LOWER) to ARFCN(RANGE1_HIGHER);
 Range2 = ARFCN(RANGE2_LOWER) to ARFCN(RANGE2_HIGHER);
 RangeNR = ARFCN(RANGENR_LOWER) to ARFCN(RANGENR_HIGHER).

If RANGE_i_LOWER is greater than RANGE_i_HIGHER, the range shall be considered cyclic and encompasses carriers with ARFCN from range RANGE_i_LOWER to 1 023 and from 0 to RANGE_i_HIGHER. If RANGE_i_LOWER equals RANGE_i_HIGHER then the range shall only consist of the carrier whose ARFCN is RANGE_i_LOWER.

If an MS includes a stored BCCH carrier list of the selected PLMN it shall perform the same measurements as in subclause 6.2 except that only the BCCH carriers in the list need to be measured.

NOTE: If the selected PLMN is equal to one of the equivalent PLMNs, then stored list cell selection applies to all equivalent PLMNs.

If stored list cell selection is not successful, then as defined in 3GPP TS 03.22, normal cell selection shall take place. Since information concerning a number of channels is already known to the MS, it may assign high priority to measurements on the strongest carriers from which it has not previously made attempts to obtain BCCH information, and omit repeated measurements on the known ones.

6.4 Criteria for cell selection and reselection

The path loss criterion parameter C1 used for cell selection and reselection is defined by:

$$C1 = (A - \text{Max}(B, 0))$$

where

A = RLA_C - RXLEV_ACCESS_MIN
 B = MS_TXPWR_MAX_CCH - P

except for the class 3 DCS 1 800 MS where:

B = MS_TXPWR_MAX_CCH + POWER_OFFSET - P
 RXLEV_ACCESS_MIN = Minimum received signal level at the MS required for access to the system.
 MS_TXPWR_MAX_CCH = Maximum TX power level an MS may use when accessing the system until otherwise commanded.
 POWER_OFFSET = The power offset to be used in conjunction with the MS TXPWR_MAX_CCH parameter by the class 3 DCS 1 800 MS.
 P = Maximum RF output power of the MS.

All values are expressed in dBm.

The path loss criterion (3GPP TS 03.22) is satisfied if $C1 > 0$.

The reselection criterion C2 is used for cell reselection only and is defined by:

$$C2 = C1 + \text{CELL_RESELECT_OFFSET} - \text{TEMPORARY_OFFSET} * H(\text{PENALTY_TIME} - T) \text{ for } \text{PENALTY_TIME} \leq 11111$$

$$C2 = C1 - \text{CELL_RESELECT_OFFSET} \text{ for } \text{PENALTY_TIME} = 11111$$

where

For non-serving cells:

$$\begin{aligned}
 H(x) &= 0 \text{ for } x < 0 \\
 &= 1 \text{ for } x \geq 0
 \end{aligned}$$

For serving cells:

$$H(x) = 0$$

T is a timer implemented for each cell in the list of strongest carriers (see subclause 6.6.1). T shall be started from zero at the time the cell is placed by the MS on the list of strongest carriers, except when the previous serving cell is placed on the list of strongest carriers at cell reselection. In this, case, T shall be set to the value of PENALTY_TIME (i.e. expired).

CELL_RESELECT_OFFSET applies an offset to the C2 reselection criterion for that cell.

NOTE: CELL_RESELECT_OFFSET may be used to give different priorities to different bands when multiband operation is used.

TEMPORARY_OFFSET applies a negative offset to C2 for the duration of PENALTY_TIME after the timer T has started for that cell.

PENALTY_TIME is the duration for which TEMPORARY_OFFSET applies. The all ones bit pattern on the PENALTY_TIME parameter is reserved to change the sign of CELL_RESELECT_OFFSET and the value of TEMPORARY_OFFSET is ignored as indicated by the equation defining C2.

CELL_RESELECT_OFFSET, TEMPORARY_OFFSET, PENALTY_TIME and CELL_BAR_QUALIFY (see table 1a) are optionally broadcast on the BCCH of the cell. If not broadcast, the default values are CELL_BAR_QUALIFY = 0, and C2 = C1. The use of C2 is described in 3GPP TS 03.22.

These parameters are used to ensure that the MS is camped on the cell with which it has the highest probability of successful communication on uplink and downlink.

The signal strength threshold criterion parameter C4 is used to determine whether prioritised LSA cell reselection shall apply and is defined by:

$$C4 = A - \text{PRIO_THR}$$

where

A is defined as above and PRIO_THR is the signal threshold for applying LSA reselection. PRIO_THR is broadcast on the BCCH. If the idle mode support is disabled for the LSA (see 3GPP TS 11.11) or if the cell does not belong to any LSA to which the MS is subscribed or if no PRIO_THR parameter is broadcast, PRIO_THR shall be set to ∞ .

6.5 Downlink signalling failure

The downlink signalling failure criterion is based on the downlink signalling failure counter DSC. When the MS camps on a cell, DSC shall be initialized to a value equal to the nearest integer to $90/N$ where N is the BS_PA_MFRMS parameter for that cell (see 3GPP TS 05.02). Thereafter, whenever the MS attempts to decode a message in its paging subchannel; if a message is successfully decoded (BFI = 0) DSC is increased by 1, however never beyond the initial value, otherwise DSC is decreased by 4. When $DSC \leq 0$, a downlink signalling failure shall be declared.

For GPRS, an MS in packet idle mode shall follow the same procedure. The counter DSC shall be initialized each time the MS leaves packet transfer mode. In case DRX period split is supported, DSC shall be initialized to a value equal to the nearest integer to $\max(10, 90 * N_{\text{DRX}})$, where N_{DRX} is the average number of monitored blocks per multiframe according to its paging group (see 3GPP TS 05.02). In non-DRX mode, the MS shall only increment/decrement DSC for one block per DRX period according to its paging group. The exact position of these blocks is not essential, only the average rate.

NOTE: The network sends the paging subchannel for a given MS every BS_PA_MFRMS multiframe or, in case DRX period split is supported, every $1/N_{\text{DRX}}$ multiframe. The requirement for network transmission on the paging subchannel is specified in 3GPP TS 04.18 or 3GPP TS 04.60. The MS is required to attempt to decode a message every time its paging subchannel is sent.

A downlink signalling failure shall result in cell reselection.

6.6 Measurements for Cell Reselection

Upon completion of cell selection and when starting the cell reselection tasks, the MS shall synchronize to and read the BCCH information for the 6 strongest non-serving carriers (in the BA) as quickly as possible within the times specified in subclause 6.6.1. For multi band MSs the strongest non-serving carriers may belong to different frequency bands. If system information message type 2 ter or 2 quater is used in the serving cell, and the MS has decoded all relevant serving cell BCCH data, except system information message 2 ter and/or 2 quater, then the MS shall start cell reselection measurements based on the know part of the BA, until system information message 2 ter and/or 2 quater is decoded and the full BA can be used.

MSs supporting SoLSA with SoLSA subscription shall perform cell re-selection according to subclause 6.6.3. Other MSs shall perform cell re-selection according to subclause 6.6.2.

MSs supporting other radio access technologies shall also perform measurements and cell-reselection according to subclauses 6.6.4 and 6.6.5

6.6.1 Monitoring of received signal level and BCCH data

Whilst in idle mode an MS shall continue to monitor all BCCH carriers as indicated by the BCCH allocation (BA - See table 1). A running average of received signal level (RLA_C) in the preceding 5 to:

$$\text{Max} \{ 5, ((5 * N + 6) \text{ DIV } 7) * \text{BS_PA_MFRMS} / 4 \}$$

seconds shall be maintained for each carrier in the BCCH allocation. N is the number of non-serving cell BCCH carriers in BA and the parameter BS_PA_MFRMS is defined in 3GPP TS 05.02.

The same number of measurement samples shall be taken for all non-serving cell BCCH carriers of the BA list, and the samples allocated to each carrier shall as far as possible be uniformly distributed over each evaluation period. At least 5 received signal level measurement samples are required per RLA_C value. New sets of RLA_C values shall be calculated as often as possible.

For the serving cell, received signal level measurement samples shall be taken at least for each paging block of the MS. The RLA_C shall be a running average determined using samples collected over a period of 5 s to Max { 5s, five consecutive paging blocks of that MS }. The samples shall as far as possible be uniformly distributed over each evaluation period. At least 5 received signal level measurement samples are required per RLA_C value. New RLA_C values shall be calculated as often as possible.

The list of the 6 strongest non-serving carriers shall be updated at least as often as the duration of the running average defined for measurements on the BCCH allocation and may be updated more frequently.

In order to minimize power consumption, MS that employ DRX (i.e. power down when paging blocks are not due) should monitor the received signal levels of non-serving cell BCCH carriers during the frames of the paging block that they are required to listen to. The MS shall include the BCCH carrier of the current serving cell (i.e. the cell the MS is camped on) in this measurement routine. Received signal level measurement samples can thus be taken on several non-serving cell BCCH carriers and on the serving carrier during each paging block.

The MS shall attempt to decode the full BCCH data of the serving cell at least every 30 seconds or at least as often as possible in the case that system information scheduling period exceeds 30 seconds.

If SI13 is broadcast, the MS supporting change mark in SI13 (See 3GPP TS 04.18) is only required to confirm system information on the BCCH of the serving cell if indicated by change mark in SI13.

The MS shall attempt to decode the BCCH data block that contains the parameters affecting cell reselection for each of the 6 strongest non-serving cell BCCH carriers at least every 5 minutes. When the MS recognizes that a new BCCH carrier has become one of the 6 strongest, the BCCH data shall be decoded for the new carrier within 30 seconds.

The MS shall attempt to check the BSIC for each of the 6 strongest non-serving cell BCCH carriers at least every 30 seconds, to confirm that it is monitoring the same cell. If a change of BSIC is detected then the carrier shall be treated as a new carrier and the BCCH data re-determined.

In addition, an MS supporting SoLSA with SoLSA subscription shall attempt to decode BSIC and the BCCH data blocks that contain the parameters affecting SoLSA cell reselection for the 6 strongest carriers, which are included both in the BCCH allocation and in the BA_PREF as received in the latest CHANNEL RELEASE message (see

04.18). At least one carrier shall be searched every 5 minutes, one after another. In the case the MS has been able to decode the BCCH data blocks, the rules described in subclause 6.6.3 shall be followed.

When requested by the user, the MS shall determine which PLMNs are available (Manual Mode) or available and allowable (Automatic Mode) (see 3GPP TS 03.22) within 10 seconds (for GSM 450), 10 seconds (for GSM 480), 15 seconds (for GSM 850 and GSM 900) or 20 seconds (for DCS 1 800 and PCS 1 900). A multi band MS shall perform the same procedures in all bands of operation within the sum of time constraints in the respective band of operation.

In both cases, this monitoring shall be done so as to minimize interruptions to the monitoring of the PCH.

The maximum time allowed for synchronization to a BCCH carrier is 0,5 s, and the maximum time allowed to read the BCCH data, when being synchronized to a BCCH carrier, is 1,9 s or equal to the scheduling period for the BCCH data, whichever is greater (see 3GPP TS 05.02).

6.6.2 Path loss criteria and timings for cell re-selection

The MS is required to perform the following measurements (see 3GPP TS 03.22) to ensure that the path loss criterion to the serving cell is acceptable.

At least every 5 s the MS shall calculate the value of C1 and C2 for the serving cell and re-calculate C1 and C2 values for non-serving cells (if necessary). The MS shall then check whether:

- i) The path loss criterion (C1) for current serving cell falls below zero for a period of 5 seconds. This indicates that the path loss to the cell has become too high.
- ii) The calculated value of C2 for a non-serving suitable cell exceeds the value of C2 for the serving cell for a period of 5 seconds, except;
 - a) in the case of the new cell being in a different location area or, for a GPRS MS, in a different routing area or always for a GPRS MS in ready state in which case the C2 value for the new cell shall exceed the C2 value of the serving cell by at least CELL_RESELECT_HYSTERESIS dB as defined by the BCCH data from the current serving cell, for a period of 5 seconds; or
 - b) in case of a cell reselection occurring within the previous 15 seconds in which case the C2 value for the new cell shall exceed the C2 value of the serving cell by at least 5 dB for a period of 5 seconds.

This indicates that it is a better cell.

Cell reselection for any other reason (see 3GPP TS 03.22) shall take place immediately, but the cell that the MS was camped on shall not be returned to within 5 seconds if another suitable cell can be found. If valid RLA_C values are not available, the MS shall wait until these values are available and then perform the cell reselection if it is still required. The MS may accelerate the measurement procedure within the requirements in subclause 6.6.1 to minimize the cell reselection delay.

If no suitable cell is found within 10 seconds, the cell selection algorithm of 3GPP TS 03.22 shall be performed. Since information concerning a number of channels is already known to the MS, it may assign high priority to measurements on the strongest carriers from which it has not previously made attempts to obtain BCCH information, and omit repeated measurements on the known ones.

6.6.3 Cell reselection algorithm for SoLSA

At least for every new sample or every second, whichever is the greatest, the MS calculate the value of C1, C2 and C4 for the serving cell and the non-serving cells. The MS shall make a cell reselection if:

- i) The path loss criterion parameter (C1) for the serving cell falls below zero for a period of 5 seconds.
- ii) A non-serving suitable cell (see 3GPP TS 03.22) is evaluated to be better than the serving cell for a period of 5 seconds. The best cell is
 - the cell with the highest value of $C2 + \text{LSA_OFFSET}$ among those cells that have highest LSA priority among those that fulfil the criteria $C4 \geq 0$, or
 - the cell with the highest value of C2 among all cells, if no cell fulfil the criterion $C4 \geq 0$.

LSA_OFFSET and LSA ID(s) are broadcast on BCCH. LSA priority is defined by the list of LSAs for the subscriber stored on the SIM (see 3GPP TS 11.11). Cells with no LSA priority, eg non-LSA cells, are given LSA priority lower than 0. If no LSA_OFFSET parameter is broadcast, LSA_OFFSET shall be set to 0.

When evaluating the best cell, the following hysteresis values shall be subtracted from the C2 value for the neighbour cells:

- if the new cell is in the same location area: 0;
- if the new cell is in a different location area:
CELL_RESELECT_HYSTERESIS, which is broadcast on BCCH of the serving cell.
- in case of a cell reselection occurred within the previous 15 seconds: 5 dB.

Cell reselection for any other reason (see 3GPP TS 03.22) shall take place immediately, but the cell that the MS was camped on shall not be returned to within 5 seconds if another suitable cell can be found. If valid receive level averages are not available, the MS shall wait until these values are available and then perform the cell reselection if it is still required. The MS may accelerate the measurement procedure within the requirements in subclause 6.6.1 to minimise the cell reselection delay.

If no suitable cell is found within 10 seconds, the cell selection algorithm of 3GPP TS 03.22 shall be performed. Since information concerning a number of channels is already known to the MS, it may assign high priority to measurements on the strongest carriers from which it has not previously made attempts to obtain BCCH information, and omit repeated measurements on the known ones.

6.6.4 Measurements on cells of other radio access technologies

For a multi-RAT MS, cells or frequencies with other radio access technologies may be included in 3G Cell Reselection list (see 3GPP TS 04.18). The network controls the measurements for reselection of these cells by the parameter Qsearch_I broadcast on BCCH. Qsearch_I defines a threshold and also indicates whether these measurements shall be performed when RLA_C (see subclause 6.6.1) of the serving cell is below or above the threshold. These measurements may be performed less frequently than measurements of GSM cells as described in subclause 6.6.1, in order to conserve MS power.

The MS shall be able to identify and select a new best UTRAN cell on a frequency, which is part of the 3G Cell Reselection list, within 30 seconds after it has been activated under the condition that there is only one UTRAN frequency in the list and under good radio conditions. For test purposes the following radio conditions can be used: Serving GSM cell at RXLEV= -70 dBm, with 6 GSM neighbours at RXLEV= -75 dBm. Then either an UTRAN FDD neighbour cell or an UTRAN TDD neighbour cell is switched on. The radio conditions for the UTRAN FDD cell are as follows (see TS 25.101 for definitions):

Parameter	Unit	UTRAN FDD Cell
<i>CPICH_Ec/Ior</i>	dB	-10
<i>PCCPCH_Ec/Ior</i>	dB	-12
<i>SCH_Ec/Ior</i>	dB	-12
<i>PICH_Ec/Ior</i>	dB	-15
<i>DPCH_Ec/Ior</i>	dB	-∞
<i>OCNS_Ec/Ior</i>	dB	-0.94
\hat{I}_{or}/I_{oc}	dB	10
<i>I_{oc}</i>	dBm/3.84 MHz	-70
<i>CPICH_Ec/Io</i>	dB	-10.4
<i>CPICH_RSCP</i>	dBm	-70
FDD_Qoffset	integer	5 (-12dB)
FDD_Qmin	integer	7 (-12 dB)
Qsearch_I	integer	7 (search always)
Propagation Condition	AWGN	

The radio conditions for the UTRAN TDD cell (3.84 Mcps) are as follows (see 3GPP TS 25.123 for definitions and for the values of the remaining configuration parameters):

Parameter	Unit	UTRA TDD Cell (3.84 Mcps)	
<i>Timeslot Number</i>		0	8
<i>P-CCPCH_Ec/Ior</i>	dB	-3	
<i>SCH_Ec/Ior</i>	dB	-9	-9
<i>SCH_{t_offset}</i>	integer	0	0
<i>PICH_Ec/Ior</i>	dB		-3
<i>OCNS_Ec/Ior</i>	dB	-3.12	-3.12
<i>PCCPCH RSCP</i>	dBm	-70	-70
<i>TDD_Qoffset</i>	integer	5 (-12 dB)	
<i>Qsearch_I</i>	integer	7 (search always)	
Propagation Condition	AWGN		

NOTE: On timeslot 8 the P-CCPCH is not transmitted; on that timeslot, the PCCPCH RSCP defines the power level of the beacon channel.

The allowed time is increased by 30 seconds for each additional UTRAN frequency in the 3G Cell Reselection list. However, multiple UTRAN cells on the same frequency in the list does not increase the allowed time.

A multi-RAT MS shall be able to monitor 64 UTRAN cells, divided into (depending on the MS capability):

- FDD cells on up to 3 FDD frequencies, with a maximum of 32 cells per frequency; and/or
- TDD cells on up to 3 TDD frequencies with a maximum of 32 cells per frequency.

The MS shall attempt to read and store UTRAN predefined configurations using the rules defined in 3GPP TS 25.331 with the following exceptions:

- The MS shall build a list of at most 16 predefined configurations, read from the BCCH of the identified UTRAN cells of equivalent PLMNs.
- After PLMN selection (see 3GPP TS 23.122), the MS shall delete any old list of predefined configurations and as soon as possible attempt to read the predefined configurations from one identified UTRAN cell of the selected PLMN or of an equivalent PLMN.
- The MS shall attempt to update the list of predefined configurations every 60 minutes.

In case of a conflict with GSM tasks, the GSM tasks take precedence.

NOTE: Instead of reading new predefined configurations from a PLMN, the MS may use previously received predefined configurations for that PLMN according to the rules in 3GPP TS 25.331.

The MS shall report the list of predefined configurations in the UTRAN CLASSMARK CHANGE message (see 3GPP TS 04.18).

6.6.5 Algorithm for cell re-selection from GSM to UTRAN

If the 3G Cell Reselection list includes UTRAN frequencies, the MS shall, at least every 5 s update the value *RLA_C* for the serving cell and each of the at least 6 strongest non-serving GSM cells.

The MS shall then reselect a suitable (see TS 25.304) UTRAN cell if:

- for a TDD cell the measured RSCP value exceeds the value of *RLA_C* for the serving cell and all of the suitable (see 3GPP TS 03.22) non-serving GSM cells by the value *XXX_Qoffset* for a period of 5 s and
- for an FDD cell the following criteria are all met for a period of 5 s:
 1. its measured RSCP value exceeds the value of *RLA_C* for the serving cell and all of the suitable (see 3GPP TS 03.22) non-serving GSM cells by the value *XXX_Qoffset*,
 2. its measured *Ec/No* value is equal or greater than the value *FDD_Qmin*, and

3. its measured RSCP value is equal to or greater than $FDD_RSCP_threshold$, if supported by the MS.

In case of a cell reselection occurring within the previous 15 seconds, $XXX_Qoffset$ is increased by 5 dB.

where

- E_c/No and RSCP are the measured quantities, see subclause 8.1.5.
- $FDD_RSCP_threshold$ equals $Q_{rxlevmin} + P_{compensation} + 10$ dB, if these parameters are available, otherwise $-\infty$ (criterion not effective).
- $Q_{rxlevmin}$ is the minimum required RX level in the UTRAN FDD cell (dBm), see 3GPP TS 25.304.
- $P_{compensation}$ is $\max(UE_TXPWR_MAX_RACH - P_MAX, 0)$ (dB), see 3GPP TS 25.304.
- $UE_TXPWR_MAX_RACH$ is the maximum TX power level an MS may use when accessing the UTRAN FDD cell on RACH (dBm), see 3GPP TS 25.304.
- P_MAX is the maximum RF output power of the MS (dBm) in UTRAN FDD mode, see 3GPP TS 25.304.
- FDD_Qmin and $XXX_Qoffset$ are broadcast on BCCH of the serving cell. XXX indicates other radio access technology/mode.

Note: The parameters required to determine if the UTRAN cell is suitable are broadcast on BCCH of the UTRAN cell. An MS may start reselection towards the UTRAN cell before decoding the BCCH of the UTRAN cell, leading to a short interruption of service if the UTRAN cell is not suitable.

The MS may store the UTRAN cell RSCP suitability criterion parameters above, whenever decoded from a UTRAN FDD cell of an equivalent PLMN. The most recently decoded parameters are valid reselection criteria towards all UTRAN FDD cells. This list of parameters shall be cleared after PLMN selection (see 3GPP TS 23.122).

Cell reselection to UTRAN shall not occur within 5 seconds after the MS has reselected a GSM cell from an UTRAN cell if a suitable GSM cell can be found.

If more than one UTRAN cell fulfils the above criteria, the MS shall select the cell with the greatest RSCP value.

6.7 Release of TCH and SDCCH

6.7.1 Normal case

When the MS releases all TCHs or SDCCH and returns to idle mode or packet idle mode, it shall, as quickly as possible, camp on the cell whose channel has just been released. If the full (P)BCCH data for that cell was not decoded in the preceding 30s, the MS shall then attempt to decode the full (P)BCCH data. Until the MS has decoded the (P)BCCH data required for determining the paging group, it shall also monitor all paging blocks on timeslot 0 of the BCCH carrier or, for GPRS if PCCCH exists, on the PDCH indicated on BCCH for possible paging messages that might address it. If the MS receives a page before having decoded the full (P)BCCH data for the cell, the MS shall store the page and respond once the relevant (P)BCCH data has been decoded, provided that the cell is not barred and the MS's access class is allowed. Reception of full BCCH(BA) information is not required before responding to the page.

If at the release of the connection the MS has the knowledge that the cell whose channel is being released is not suitable (see 3GPP TS 03.22), the MS is allowed to camp on any suitable cell.

NOTE: The received signal level measurements on surrounding cells made during the last 5 seconds on the TCH or SDCCH may be averaged and used, where possible, to speed up the process. However, it should be noted that the received signal level monitoring while on the TCH or SDCCH is on carriers in BA (SACCH), while the carriers to be monitored for cell reselection are in BA (BCCH) or BA (GPRS).

After decoding the relevant (P)BCCH data the MS shall perform cell reselection as specified in 3GPP TS 03.22.

6.7.2 Call re-establishment

In the event of a radio link failure, call re-establishment may be attempted (according to the procedure in 3GPP TS 04.18). The MS shall perform the following algorithm to determine which cell to use for the call re-establishment attempt.

- i) The received signal level measurement samples taken on the carriers indicated in the BA (SACCH) received on the serving cell and on the serving cell BCCH carrier in the last 5 seconds shall be averaged, and the carrier with the highest average received signal level with a permitted NCC as indicated on the SACCH of the serving cell (see subclause 7.2) shall be taken.
- ii) On this carrier the MS shall attempt to decode the BCCH data block containing the parameters affecting cell selection.
- iii) If the cell is suitable (see 3GPP TS 03.22) and call re-establishment is allowed, call re-establishment shall be attempted on this cell.
- iv) If the MS is unable to decode the BCCH data block or if the conditions in iii) are not met, the carrier with the next highest average received signal level with a permitted NCC shall be taken, and the MS shall repeat steps ii) and iii) above.
- v) If the cells with the 6 strongest average received signal level values with a permitted NCC have been tried but cannot be used, the call re-establishment attempt shall be abandoned, and the algorithm of subclause 6.7.1 shall be performed.

The MS is under no circumstances allowed to access a cell to attempt call re-establishment later than 20 seconds after the detection within the MS of the radio link failure causing the call re-establishment attempt. In the case where the 20 seconds elapses without a successful call re-establishment the call re-establishment attempt shall be abandoned, and the algorithm of subclause 6.7.1 shall be performed.

Call re-establishment shall not be applied for voice group calls.

6.8 Abnormal cases and emergency calls

When in the limited service state (see 3GPP TS 03.22) the aim is to gain normal service rapidly and the following tasks shall be performed, depending on the conditions, as given in the table below:

- a) The MS shall monitor the received signal level of all RF channels within its bands of operation, and search for a BCCH carrier which has $C1 > 0$ and which is not barred. When such a carrier is found, the MS shall camp on that cell, irrespective of the PLMN identity.
- b) The MS shall search the strongest RF channels to determine which PLMNs are available (Manual Mode) or available and allowable (Automatic Mode). This information shall be processed according to the PLMN selection algorithm defined in 3GPP TS 03.22.
- c) The MS shall perform cell reselection at least among the cells of the PLMN of the cell on which the MS has camped, according to the algorithm of 3GPP TS 03.22, except that a zero value of CELL_RESELECT_HYSTERESIS shall be used.

Condition			Tasks to be performed as a minimum:		
SIM Present	Other	MS camped on a cell	a)	b)	c)
X	X	No	Yes	No	No
No	X	Yes	No	No	Yes
Yes	"IMSI Unknown", "illegal MS"	Yes	No	No	Yes
Yes	No suitable cell of selected PLMN or "PLMN not allowed"	Yes	No	Yes	Yes

NOTE: X = "Don't care state".

In this mode, only emergency calls may be made (and these may only be made if task c) was being performed). Powering down of the MS is permitted.

7 Network pre-requisites

7.1 BCCH carriers

The BCCH carrier shall be continuously transmitted on all timeslots and without variation of RF level. However, the RF power level may be ramped down between timeslots to facilitate switching between RF transmitters.

Furthermore, 8-PSK modulated timeslots on the BCCH carrier, with the exception of TN 7, may use a mean power which is at most 4 dB lower than the power used for GMSK modulated timeslots. The MS requirements on signal strength measurements are defined for the case when only GMSK modulation is used on the BCCH carrier. There are no defined signal strength measurement requirements for the MS if 8-PSK modulation is used on the BCCH carrier.

On the PCH the network shall send valid layer 3 messages according to 3GPP TS 04.18. Unused signalling blocks on the CCCH/BCCH shall contain L2 fill frames. Other unused timeslots shall transmit dummy bursts.

The number of neighbour cell BCCH carriers in the BCCH allocation shall not exceed 32.

- NOTE 1: This BCCH organization enables MS to measure the received signal level from surrounding cells by tuning and listening to their BCCH carriers. Providing that an MS tunes to the list of BCCH carriers indicated by the network it will, providing the list is sufficiently complete, have listened to all possible surrounding cells, i.e. the surrounding cell list for handover purposes is effectively defined by the MS. Refer to 3GPP TS 03.22 for definitions of the BCCH carrier lists. This can be achieved without inter-base station synchronization.
- NOTE 2: If the operator decides to allow 8-PSK modulation on the BCCH carrier in certain cells, the cell selection, cell reselection and handover procedures involving these cells will be somewhat sub-optimal. This is due to the fact that the signal level measured by the MS at some instances in time will be affected by the possibly lower mean power level of the 8-PSK modulation and by the power fluctuation resulting from the 8-PSK modulation characteristics. The extent of the performance degradation is dependent upon the measurement schedule in each particular MS as well as upon the used average power decrease (APD) and the current 8-PSK load. By limiting the maximum number of 8-PSK slots simultaneously allowed on the BCCH carrier, and/or carefully selecting the values of involved network parameters, the impact on the above mentioned procedures may be minimised. Additionally, in areas with very low cell overlap, some coverage loss effects may have to be taken into account by the operator when selecting network parameters.
- NOTE 3: In the case that 8-PSK modulation is allowed on the BCCH carrier and frequency hopping including the BCCH carrier is used, the reception quality in connected mode for some fast moving MS (meaning MS experiencing Doppler frequencies of 100 Hz or more) may be degraded. This may be seen as a backwards compatibility problem for some existing MS, most likely occurring if the used APD is larger than 2 dB.

7.2 Identification of surrounding BSS for handover measurements

It is essential for the MS to identify which surrounding BSS is being measured in order to ensure reliable handover. Because of frequency re-use with small cluster sizes, the BCCH carrier frequency may not be sufficient to uniquely identify a surrounding cell, i.e. the cell in which the MS is situated may have more than one surrounding cell using the same BCCH frequency. Thus it is necessary for the MS to synchronize to and demodulate surrounding BCCH carriers and identify the base station identification code (BSIC). The MS shall be able to perform this task at levels down to the reference sensitivity level or reference interference levels as specified in 3GPP TS 05.05.

The MS shall use at least 4 spare frames per SACCH block period for the purpose of decoding the BSICs (e.g. in the case of TCH/F, the four idle frames per SACCH block period). These frames are termed "search" frames.

A 6 bit Base Station Identity Code (BSIC), as defined in 3GPP TS 03.03, shall be transmitted on each BCCH carrier. The PLMN part of the BSIC can be regarded as a "PLMN colour code".

The MS shall attempt to demodulate the SCH on the BCCH carrier of as many surrounding cells as possible, and decode the BSIC as often as possible, and as a minimum at least once every 10 seconds. A multi-RAT MS is allowed to extend this period to 13 seconds, if the neighbour cell list contains cells from other RATs and if indicated

by the parameter 3G_SEARCH_PRIO. The MS shall give priority for synchronization attempts in signal strength order and considering the parameter MULTIBAND_REPORTING. A list containing information about the timing of the surrounding cells at the accuracy required for accessing a cell (see 3GPP TS 05.10) including the absolute times derived from the parameters T1, T2, T3 shall be kept by the MS. This information may be used to schedule the decoding of BSIC and shall be used in connection with handover in order to keep the switching time at a minimum. The network may provide Real Time Difference (RTD, see 3GPP TS 05.10) to assist the MS in neighbour cell synchronization attempts. This assistance data is included in the MEASUREMENT INFORMATION message (See 04.18). RTD is provided modulo one multiframe (51 TDMA frames). The resolution is either one TDMA frame, in which case the MS can assume that the cells are frame synchronised, or 1/64 TDMA frame. The MS may use other assistance data too, if received elsewhere, e.g. for position services received information. The actual number of carriers the MS is capable of synchronising to, depends on the Observed Time Difference (OTD, see 05.10) for each neighbour cell and the availability of the assistance information.

If, after averaging measurement results over 2 SACCH block periods, the MS detects one or more BCCH carriers, among the 6 strongest, whose BSICs are not currently being assessed, then the MS shall as a matter of priority attempt to decode their BSICs.

In the case of a multi band MS, the MS shall attempt to decode the BSIC, if any BCCH carrier with unknown BSIC is detected among the number of strongest BCCH carriers in each band as indicated by the parameter MULTIBAND_REPORTING.

Thus an MS shall, for a period of up to 5 seconds, devote all search frames to attempting to decode these BSICs. If this fails then the MS shall return to confirming existing BSICs. Having re-confirmed existing BSICs, if there are still BCCH carriers, among the six strongest, with unknown BSICs, then the decoding of these shall again be given priority for a further period of up to 5 seconds.

The MS shall report a new strongest GSM cell in the measurement report at the latest 5 s after a new strongest cell (which is part of the BA(SACCH)) has been activated under the following network conditions: Initial serving cell at RXLEV= -70 dBm, with 6 neighbours at RXLEV= -75 dBm. Then the new BCCH carrier is switched on at RXLEV= -60 dBm.

NOTE: Because of test equipment limitations it is acceptable to activate the new carrier to replace one of the 6 neighbours.

If either no BSIC can be demodulated on a surrounding cell BCCH carrier, or the BSIC is not allowed, then the received signal level measurements on that channel shall be discarded. The allowed BSIC is either the BSIC broadcast for that carrier in the neighbour cell list or, if no BSIC is included or if indicated by the parameter INVALID_BSIC_REPORTING, a BSIC with permitted NCC part. The permitted NCCs are defined by the NCC_PERMITTED parameter transmitted in the BCCH data. This is an 8 bit map that relates to the NCC part of BSIC (e.g. NCC_PERMITTED = 01101001, defines that only carriers having a BSIC with the NCC part = 000, 011, 101, 110 shall be reported).

If a change of BSIC is detected on a carrier, then any existing received signal level measurement shall be discarded and a new averaging period commenced. This occurs when the MS moves away from one surrounding cell and closer to another co-channel cell.

If the BSIC cannot be decoded at the next available opportunities re-attempts shall be made to decode this BSIC. If the BSIC is not decoded for more than three successive attempts it will be considered lost and any existing received signal level measurement shall be discarded.

If an MS receives a handover command towards a GSM cell to which it is not synchronised to, then the MS shall search for synchronisation information up to 300 ms. In case of failure, the MS shall refer to the handover failure procedure (see 3GPP TS 04.18).

If a multi-RAT MS receives a handover command towards a not known cell (see 3GPP TS 25.133 and 3GPP TS 25.123), then the multi-RAT MS shall search for synchronisation information up to 800 ms. In case of failure, the multi-RAT MS shall refer to the handover failure procedure (see 3GPP TS 04.18).

Details of the synchronization mechanisms appear in 3GPP TS 05.10. The procedure for monitoring surrounding BTS with respect to HO measurement shall begin at least at the time of assignment of a dedicated channel.

When a BCCH carrier is found to be no longer among the reported, timing and BSIC information shall be retained for at least 10 seconds. (This is in case a handover is commanded to this cell just after the MS stops reporting RXLEV and RXQUAL on this cell).

7.3 Handover measurements on other radio access technologies

For a multi-RAT MS, the network controls the identification and measurements of cells belonging to other radio access technologies by the parameter *Qsearch_C* sent on SACCH or, if *Qsearch_C* is not received, by *Qsearch_C_Initial* sent on BCCH. *Qsearch_C* defines a threshold and also indicates whether these tasks shall be performed when RXLEV (see subclause 8.1.3) of the serving cell is below or above the threshold. The MS may use the search frames, which are not required for BSIC decoding, for these measurements. If indicated by the parameter *3G_SEARCH_PRIO*, the MS may use up to 25 search frames per 13 seconds without considering the need for BSIC decoding in these frames.

The MS shall report a new best UTRAN cell, which is part of the neighbour cell list, at the latest 5 seconds after it has been activated under the condition that there is only one UTRAN frequency in the neighbour cell list and that no new GSM cells are activated at the same time and under good radio conditions. For test purposes the following radio conditions can be used: Serving GSM cell at RXLEV= -70 dBm, with 6 GSM neighbours at RXLEV= -75 dBm. Then either an UTRAN FDD neighbour cell or an UTRAN TDD neighbour cell is switched on. The radio conditions for the UTRAN FDD cell are as follows (see TS 25.101 for definitions):

Parameter	Unit	UTRAN FDD Cell
<i>CPICH_Ec/Ior</i>	dB	-10
<i>PCCPCH_Ec/Ior</i>	dB	-12
<i>SCH_Ec/Ior</i>	dB	-12
<i>PICH_Ec/Ior</i>	dB	-15
<i>DPCH_Ec/Ior</i>	dB	$-\infty$
<i>OCNS</i>		-0.94
\hat{I}_{or}/I_{oc}	dB	10
<i>I_{oc}</i>	dBm/3.84 MHz	-70
<i>CPICH_Ec/Io</i>	dB	-10.4
<i>CPICH_RSCP</i>	dBm	-70
FDD_MULTIRAT_REPORTING	integer	1
<i>Qsearch_C</i>	integer	7 (search always)
<i>3G_SEARCH_PRIO</i>	integer	1
Propagation Condition	AWGN	

The radio conditions for the UTRAN TDD cell (3.84 Mcps) are as follows (see 3GPP TS 25.123 for definitions and for the values of the remaining configuration parameters):

Parameter	Unit	UTRA TDD Cell (3.84 Mcps)	
<i>Timeslot Number</i>		0	8
<i>P-CCPCH_Ec/Ior</i>	dB	-3	
<i>SCH_Ec/Ior</i>	dB	-9	-9
<i>SCH_{t_offset}</i>	integer	0	0
<i>PICH_Ec/Ior</i>	dB		-3
<i>OCNS_Ec/Ior</i>	dB	-3.12	-3.12
<i>PCCPCH_RSCP</i>	dBm	-70	-70
TDD_MULTIRAT_REPORTING	integer	1	
<i>Qsearch_C</i>	integer	7 (search always)	
<i>3G_SEARCH_PRIO</i>	integer	1	
Propagation Condition	AWGN		

NOTE: On timeslot 8 the P-CCPCH is not transmitted; on that timeslot, the PCCPCH RSCP defines the power level of the beacon channel.

The allowed reporting time is increased by 5 seconds for each additional UTRAN frequency in the neighbour cell list and by the time required for BSIC decoding of new activated GSM cells. However, multiple UTRAN cells on the same frequency in the neighbour cell list does not increase the allowed reporting time.

When on TCH, identification of a TDD cell is guaranteed only in case of single slot operation and if the TDD cell uses synchronisation option 2 (see 3GPP TS 25.221). In all other cases, the MS may not be able to fulfil the requirement above. If after 5 seconds the MS has not been able to identify a TDD cell, the MS is allowed to stop searching for it in the current GSM cell.

When on SDCCH, the MS may use all TDMA frames, which are not part of the allocated channel or required for GSM signal strength measurements, for the above task. In this case the allowed reporting time is 1.7 seconds, with the same assumptions as above.

A multi-RAT MS shall be able to monitor 64 cells from other radio access technologies, divided into (depending on the MS capability):

- FDD cells on up to 3 FDD frequencies, with a maximum of 32 cells per frequency
- TDD cells on up to 3 TDD frequencies, with a maximum of 32 cells per frequency; and/or
- CDMA2000 cells.

8 Radio link measurements

Radio link measurements are used in the handover and RF power control processes.

In particular, radio-subsystem directed handover is defined as a change of channel(s) during a call either because of degradation of the quality of one or more of the current serving channel(s), or because of the availability of other channel(s) which can allow communication at a lower TX power level, or to prevent a MS grossly exceeding the planned cell boundaries.

Additional measurements, so called Extended measurements, can e.g. be used for frequency planning purposes.

The measurements are made over each SACCH multiframe, which is 104 TDMA frames (480 ms) for a TCH and 102 TDMA frames (470,8 ms) for an SDCCH. Additionally, when in E-TCH mode, quality measurements shall also be made over each FPC reporting period.

For a multi-RAT MS, measurements on other radio access technologies may be performed during search frames that are not required for BSIC decoding. If indicated by the parameter `3G_SEARCH_PRIO`, the MS may use up to 25 search frames per 13 seconds without considering the need for BSIC decoding in these frames.

8.1 Signal level

8.1.1 General

The received signal level may be employed as a criterion in the RF power control and handover processes. For cells of other radio access technology, RXLEV is replaced by the relevant measurement quantity for that radio access technology (see subclause 8.1.5).

8.1.2 Physical parameter

The R.M.S received signal level at the receiver input shall be measured by the MS and the BSS over the full range of -110 dBm to -48 dBm with an absolute accuracy of ± 4 dB from -110 dBm to -70 dBm under normal conditions and ± 6 dB over the full range under both normal and extreme conditions. The R.M.S received signal level at the receiver input shall be measured by the MS above -48 dBm up to -38 dBm with an absolute accuracy of ± 9 dB under both normal and extreme conditions.

If the received signal level falls below the reference sensitivity level for the type of MS or BSS, then the measured level shall be within the range allowing for the absolute accuracy specified above. In case the upper limit of this range is below the reference sensitivity level for the type of MS or BSS, then the upper limit shall be considered as equal to the reference sensitivity level.

The relative accuracy shall be as follows:

If signals of level x_1 and x_2 dBm are received (where $x_1 \leq x_2$) and levels y_1 and y_2 dBm respectively are measured, if $x_2 - x_1 < 20$ dB and x_1 is not below the reference sensitivity level, then y_1 and y_2 shall be such that:

$(x_2 - x_1) - a \leq y_2 - y_1 \leq (x_2 - x_1 + b)$ if the measurements are on the same or on different RF channel within the same frequency band;

and

$(x_2 - x_1) - c \leq y_2 - y_1 \leq (x_2 - x_1 + d)$ if the measurements are on different frequency bands:

a, b, c and d are in dB and depend on the value of x_1 as follows:

	<u>a</u>	<u>b</u>	<u>c</u>	<u>d</u>
$x_1 \geq s+14, x_2 < -48$ dBm	2	2	4	4
$s+14 > x_1 \geq s+1$	3	2	5	4
$s+1 > x_1$	4	2	6	4

For single band MS or BTS and measurements between ARFCN in the same band for a multiband MS or BTS;

s = reference sensitivity level as specified in 3GPP TS 05.05.

For measurements between ARFCN in different bands;

s = the reference sensitivity level as specified in 3GPP TS 05.05 for the band including x_1 .

At extreme temperature conditions an extra 2 dB shall be added to c and d in above table.

The selectivity of the received signal level measurement shall be as follows:

- for adjacent (200 kHz) channel ≥ 16 dB;
- for adjacent (400 kHz) channel ≥ 48 dB;
- for adjacent (600 kHz) channel ≥ 56 dB.

The selectivity shall be met using random, continuous, GSM-modulated signals with the wanted signal at the level 20 dB above the reference sensitivity level.

8.1.3 Statistical parameters

For each channel, the measured parameters (RXLEV) shall be the average of the received signal level measurement samples in dBm taken on that channel within the reporting period of length one SACCH multiframe defined in 8.4. In averaging, measurements made during previous reporting periods shall always be discarded.

When assigned a TCH or SDCCH the MS shall make a received signal level measurement:

- in every TDMA frame on at least one of the BCCH carriers indicated in the BCCH allocation (BA), one after another. Optionally, measurements during up to 8 frames per SACCH multiframe may be omitted;

As an exception, a multi-RAT MS may omit GSM measurements during up to 9 TDMA frames per SACCH multiframe and use these periods for measurements on other radio access technologies.

Furthermore, an MS on SDCCH is allowed schedule the measurements freely within the SACCH multiframe as long as the total number of measurement samples is maintained and the samples on each carrier are evenly spaced.

NOTE: These eight frames are the search frames and the frames immediately preceding the search frames, in order to allow the MS to search for BCCH synchronization (or inter-RAT measurements) over a full TDMA frame.

- for each assigned bi-directional channel, on all bursts of the associated physical channel (see 3GPP TS 05.02), including those of the SACCH. If frequency hopping is being used on the associated physical channel and if, in the BCCH Cell Options, the Power Control Indicator PWRC is set, measurements on the bursts on the BCCH frequency shall not be used in the RXLEV averaging process.

Unless otherwise specified by the operator, for any TCH or SDCCH assigned to an MS, the BSS shall make a received signal level measurement on all time slots of the associated physical channel including those of the SACCH, but excluding the idle timeslots.

8.1.4 Range of parameter

The measured signal level shall be mapped to an RXLEV value between 0 and 63, as follows:

RXLEV	0	=	less than	-110 dBm + SCALE.
RXLEV	1	=	-110 dBm + SCALE	to -109 dBm + SCALE.
RXLEV	2	=	-109 dBm + SCALE	to -108 dBm + SCALE.
	:			
	:			
RXLEV	62	=	-49 dBm + SCALE	to -48 dBm + SCALE.
RXLEV	63	=	greater than	-48 dBm + SCALE.

where SCALE is an offset that is used only in the ENHANCED MEASUREMENT REPORT message, otherwise it is set to 0.

The MS shall use the SCALE value as indicated by the parameter SCALE_ORD in the MEASUREMENT INFORMATION message (see 3GPP TS 04.18 and 3GPP TS 04.60). If automatic scaling mode is indicated by SCALE_ORD, the MS shall choose the lowest SCALE value that is sufficient for reporting the strongest signal level within each ENHANCED MEASUREMENT REPORT message.

The MS shall indicate the used SCALE value in each individual ENHANCED MEASUREMENT REPORT message (see 3GPP TS 04.18).

8.1.5 Measurement quantity for other radio access technologies

8.1.5.1 UTRAN FDD

For UTRAN FDD cells, the measurement quantities to be used are CPICH Ec/No and CPICH RSCP and RSSI. The measurement requirements are defined in TS 25.133.

RSCP shall be used for the cell re-selection ranking criteria. Ec/No, and optionally RSCP, shall be used for a minimum quality requirement. Either RSCP or Ec/No shall be used for measurement reporting as indicated by the parameter FDD_REP_QUANT, sent on BCCH, SACCH, PBCCH and PACCH. In addition, if a frequency without scrambling code is included in the neighbour cell list, RSSI shall be reported for that frequency.

The measured value shall replace RXLEV in the measurement reports. The mapping is defined in TS 25.133. For RSCP and RSSI, values above 63 shall be reported as 63. For Ec/No, the full value range is not used.

8.1.5.2 UTRAN TDD

For UTRAN TDD cells, the measurement quantity to be used is PCCPCH RSCP. The measurement requirements are defined in TS 25.123.

NOTE: The RSCP may alternatively be measured on any beacon channel (see 3GPP TS 25.221).

The measured value shall replace RXLEV in the measurement reports. The mapping is defined in TS 25.123. For RSCP, values above 63 shall be reported as 63.

8.1.5.3 cdma2000

For cdma2000 cells, the measurement quantity to be used is PILOT_STRENGTH of the pilot. The measurement requirements are defined in TIA/EIA/IS-2000-5-A.

The measured value shall replace RXLEV in the measurement reports.

8.2 Signal quality

8.2.1 General

The received signal quality shall be employed as a criterion in the RF power control and handover processes.

8.2.2 Physical parameter

The received signal quality shall be measured by the MS and BSS in a manner that can be related to an equivalent average BER before channel decoding (i.e. chip error ratio), assessed over the reporting period of 1 SACCH block.

For FPC, the received signal quality for each E-TCH shall be measured by the MS and BSS in a manner that can be related to the average BER before channel decoding, assessed over one FPC reporting period.

For example, the measurement may be made as part of the channel equalization process, decoding process, pseudo-error rate measurement etc.

For MEAN_BEP and CV_BEP reporting purposes, the received signal quality for each channel shall be measured on a burst-by-burst basis by the MS and BSS in a manner that can be related to the BEP (Bit Error Probability) for each burst before channel decoding using, for example, soft output from the receiver.

8.2.3 Statistical parameters

For each channel, the measured parameters (RXQUAL) shall be the received signal quality, averaged on that channel over the reporting period of length one SACCH multiframe defined in subclause 8.4. In averaging, measurements made during previous reporting periods shall always be discarded.

Contrary to RXLEV measurements, in calculating RXQUAL values, measurements on bursts on the BCCH carrier shall always be included in the averaging process.

For E-TCH the average BER shall for every FPC reporting period be mapped to the RXQUAL scale according to chapter 8.2.4, producing the parameter RXQUAL_FAST which is reported to the network via E-IACCH.

For TCH, E-TCH, SDCCH, SACCH and FACCH, the MS shall calculate the following values for the last 4 consecutive slots of each fully received and correctly decoded block (see subclause 8.4.8.2):

- Mean Bit Error Probability (BEP) of the block:

$$MEAN_BEP_{block} = \frac{1}{4} \sum_{i=1}^4 BEP_{burst i}$$

- Coefficient of variation of the Bit Error Probability of the block:

$$CV_BEP_{block} = \frac{\sqrt{\frac{1}{3} \sum_{k=1}^4 \left(BEP_{burst k} - \frac{1}{4} \sum_{i=1}^4 BEP_{burst i} \right)^2}}{\frac{1}{4} \sum_{i=1}^4 BEP_{burst i}}$$

Note: The receiver needs to detect if a block has been fully received (i.e. estimate whether it was fully transmitted) when DTX is used because a block may be correctly decoded even if the last 4 slots were actually not transmitted, especially in the case of 19 interleaving.

The calculated values shall be averaged (on a linear scale) over the reporting period as follows:

MEAN_BEP = average of MEAN_BEP_{block}.

CV_BEP = average of CV_BEP_{block}.

In averaging, measurements made during previous reporting periods shall always be discarded.

For EGPRS, the MS shall calculate the following values for each radio block (4 bursts) addressed to it:

- Mean Bit Error Probability (BEP) of a radio block:

$$MEAN_BEP_{block} = \frac{1}{4} \sum_{i=1}^4 BEP_{burst i}$$

- Coefficient of variation of the Bit Error Probability of a radio block:

$$CV_BEP_{block} = \frac{\sqrt{\frac{1}{3} \sum_{k=1}^4 \left(BEP_{burst k} - \frac{1}{4} \sum_{i=1}^4 BEP_{burst i} \right)^2}}{\frac{1}{4} \sum_{i=1}^4 BEP_{burst i}}$$

Filtering and reporting are described in subclause 10.2.3.2.

8.2.4 Range of parameter RXQUAL

When the quality is assessed over the full-set and sub-set of frames defined in subclause 8.4, eight levels of RXQUAL are defined and shall be mapped to the equivalent BER before channel decoding as follows:

RXQUAL_0		BER < 0,2 %	Assumed value = 0,14 %
RXQUAL_1	0,2 %	< BER < 0,4 %	Assumed value = 0,28 %
RXQUAL_2	0,4 %	< BER < 0,8 %	Assumed value = 0,57 %
RXQUAL_3	0,8 %	< BER < 1,6 %	Assumed value = 1,13 %
RXQUAL_4	1,6 %	< BER < 3,2 %	Assumed value = 2,26 %
RXQUAL_5	3,2 %	< BER < 6,4 %	Assumed value = 4,53 %
RXQUAL_6	6,4 %	< BER < 12,8 %	Assumed value = 9,05 %
RXQUAL_7	12,8 %	< BER	Assumed value = 18,10 %

The assumed values may be employed in any averaging process applied to RXQUAL.

The same mapping table applies also for RXQUAL_FAST.

The BER values used to define a quality band are the estimated error probabilities before channel decoding, averaged over the full set or sub set of TDMA frames as defined in subclause 8.4. The accuracy to which an MS shall be capable of estimating the error probabilities when on a TCH under static channel conditions is given in the following table. Note the exception of subclause 8.4 on data channels using interleaving depth 19 and on half rate speech channel.

Quality Band	Range of actual BER	Probability that the correct RXQUAL band is reported by MS shall exceed			
		Full rate Channel	Half rate Channel	DTX Mode	ECSD FPC mode
RXQUAL_0	Less than 0,1 %	90 %	90 %	65 %	70 %
RXQUAL_1	0,26 % to 0,30 %	75 %	60 %	35 %	60 %
RXQUAL_2	0,51 % to 0,64 %	85 %	70 %	45 %	60 %
RXQUAL_3	1,0 % to 1,3 %	90 %	85 %	45 %	60 %
RXQUAL_4	1,9 % to 2,7 %	90 %	85 %	60 %	60 %
RXQUAL_5	3,8 % to 5,4 %	95 %	95 %	70 %	90 %
RXQUAL_6	7,6 % to 11,0 %	95 %	95 %	80 %	90 %
RXQUAL_7	Greater than 15,0 %	95 %	95 %	85 %	90 %

NOTE 1: For the full rate channel RXQUAL_FULL is based on 104 TDMA frames.

NOTE 2: For the half rate channel RXQUAL_FULL is based on 52 TDMA frames.

NOTE 3: For the DTX mode RXQUAL_SUB is based on 12 TDMA frames.

NOTE 4: For the ECSD FPC mode RXQUAL_FAST is based on 4 TDMA frames.

The accuracy to which an MS shall be capable of estimating the error probabilities when on a TCH under TU50 channel conditions is given in the following table. Note the exception of subclause 8.4 on data channels using interleaving depth 19 and on half rate speech channel.

Range of actual BER	Expected RXQUAL_FULL	Probability that expected RXQUAL_FULL is reported shall exceed
Less than 0,1 %	RXQUAL_0/1	85 %
0,26 % to 0,30 %	RXQUAL_1/0/2	85 %
0,51 % to 0,64 %	RXQUAL_2/1/3	85 %
1,0 % to 1,3 %	RXQUAL_3/2/4	75 %
1,9 % to 2,7 %	RXQUAL_4/3/5	75 %
3,8 % to 5,4 %	RXQUAL_5/4/6	90 %
7,6 % to 11,0 %	RXQUAL_6/5/7	90 %
Greater than 15,0 %	RXQUAL_7/6	90 %

It should be noted that in the testing, the System Simulator (SS) or (BSSTE) Base Station System Test Equipment will have to measure the average error rate over a large number of TDMA frames.

8.2.5 Range of parameters MEAN_BEP and CV_BEP

The mapping of the MEAN_BEP to the equivalent BEP and the accuracies to which an MS shall be capable of estimating the quality parameters under static channel conditions are given in the following tables for GMSK and 8-PSK respectively. The accuracy requirements below apply for EGPRS for sensitivity limited operation for signal levels above the reference sensitivity level for the type of MS. Filtering according to subclause 10.2.3.2.1 with forgetting factor of 0.03 is assumed.

MEAN_BEP mapping and accuracy for GMSK

MEAN_BEP	Range of log ₁₀ (actual BEP)	Expected MEAN_BEP interval	Probability that the expected MEAN_BEP is reported shall not be lower than:
MEAN_BEP_0	> -0.60	MEAN_BEP_0/1	80 %
MEAN_BEP_1	-0.70 -- -0.60	MEAN_BEP_1/0/2	80 %
MEAN_BEP_2	-0.80 -- -0.70	MEAN_BEP_2/1/3	75 %
MEAN_BEP_3	-0.90 -- -0.80	MEAN_BEP_3/2/4	75 %
MEAN_BEP_4	-1.00 -- -0.90	MEAN_BEP_4/3/5	75 %
MEAN_BEP_5	-1.10 -- -1.00	MEAN_BEP_5/4/6	75 %
MEAN_BEP_6	-1.20 -- -1.10	MEAN_BEP_6/5/7	75 %
MEAN_BEP_7	-1.30 -- -1.20	MEAN_BEP_7/6/8	75 %
MEAN_BEP_8	-1.40 -- -1.30	MEAN_BEP_8/7/9	75 %
MEAN_BEP_9	-1.50 -- -1.40	MEAN_BEP_9/8/10	75 %
MEAN_BEP_10	-1.60 -- -1.50	MEAN_BEP_10/9/11	70 %
MEAN_BEP_11	-1.70 -- -1.60	MEAN_BEP_11/10/12	70 %
MEAN_BEP_12	-1.80 -- -1.70	MEAN_BEP_12/11/13	70 %
MEAN_BEP_13	-1.90 -- -1.80	MEAN_BEP_13/12/14	70 %
MEAN_BEP_14	-2.00 -- -1.90	MEAN_BEP_14/13/15	70 %
MEAN_BEP_15	-2.10 -- -2.00	MEAN_BEP_15/13/14/16/17	80 %
MEAN_BEP_16	-2.20 -- -2.10	MEAN_BEP_16/14/15/17/18	80 %
MEAN_BEP_17	-2.30 -- -2.20	MEAN_BEP_17/15/16/18/19	80 %
MEAN_BEP_18	-2.40 -- -2.30	MEAN_BEP_18/16/17/19/20	80 %
MEAN_BEP_19	-2.50 -- -2.40	MEAN_BEP_19/17/18/20/21	80 %
MEAN_BEP_20	-2.60 -- -2.50	MEAN_BEP_20/18/19/21/22	80 %
MEAN_BEP_21	-2.70 -- -2.60	MEAN_BEP_21/19/20/22/23	80 %
MEAN_BEP_22	-2.80 -- -2.70	MEAN_BEP_22/20/21/23/24	80 %
MEAN_BEP_23	-2.90 -- -2.80	MEAN_BEP_23/21/22/24/25	80 %
MEAN_BEP_24	-3.00 -- -2.90	MEAN_BEP_24/22/23/25/26	80 %
MEAN_BEP_25	-3.10 -- -3.00	MEAN_BEP_25/22/23/24/26/27/28	75 %
MEAN_BEP_26	-3.20 -- -3.10	MEAN_BEP_26/23/24/25/27/28/29	75 %
MEAN_BEP_27	-3.30 -- -3.20	MEAN_BEP_27/24/25/26/28/29/30	75 %
MEAN_BEP_28	-3.40 -- -3.30	MEAN_BEP_28/25/26/27/29/30/31	75 %
MEAN_BEP_29	-3.50 -- -3.40	MEAN_BEP_29/26/27/28/30/31	90 %
MEAN_BEP_30	-3.60 -- -3.50	MEAN_BEP_30/27/28/29/31	90 %
MEAN_BEP_31	< -3.60	MEAN_BEP_31/28/29/30	90 %

MEAN_BEP mapping and accuracy for 8PSK

MEAN_BEP	Range of log10(actual BEP)	Expected MEAN_BEP interval	Probability that the expected MEAN_BEP is reported shall not be lower than:
MEAN_BEP_0	> -0.60	MEAN_BEP_0/1/2	85 %
MEAN_BEP_1	-0.64 -- -0.60	MEAN_BEP_1/0/2/3	85 %
MEAN_BEP_2	-0.68 -- -0.64	MEAN_BEP_2/0/1/3/4	85 %
MEAN_BEP_3	-0.72 -- -0.68	MEAN_BEP_3/1/2/4/5	85 %
MEAN_BEP_4	-0.76 -- -0.72	MEAN_BEP_4/2/3/5/6	85 %
MEAN_BEP_5	-0.80 -- -0.76	MEAN_BEP_5/3/4/6/7	85 %
MEAN_BEP_6	-0.84 -- -0.80	MEAN_BEP_6/4/5/7/8	85 %
MEAN_BEP_7	-0.88 -- -0.84	MEAN_BEP_7/5/6/8/9	85 %
MEAN_BEP_8	-0.92 -- -0.88	MEAN_BEP_8/6/7/9/10	80 %
MEAN_BEP_9	-0.96 -- -0.92	MEAN_BEP_9/7/8/10/11	80 %
MEAN_BEP_10	-1.00 -- -0.96	MEAN_BEP_10/8/9/11/12	80 %
MEAN_BEP_11	-1.04 -- -1.00	MEAN_BEP_11/9/10/12/13	80 %
MEAN_BEP_12	-1.08 -- -1.04	MEAN_BEP_12/10/11/13/14	80 %
MEAN_BEP_13	-1.12 -- -1.08	MEAN_BEP_13/11/12/14/15	80 %
MEAN_BEP_14	-1.16 -- -1.12	MEAN_BEP_14/12/13/15/16	85 %
MEAN_BEP_15	-1.20 -- -1.16	MEAN_BEP_15/13/14/16	85 %
MEAN_BEP_16	-1.36 -- -1.20	MEAN_BEP_16/14/15/17	85 %
MEAN_BEP_17	-1.52 -- -1.36	MEAN_BEP_17/16/18	95 %
MEAN_BEP_18	-1.68 -- -1.52	MEAN_BEP_18/17/19	95 %
MEAN_BEP_19	-1.84 -- -1.68	MEAN_BEP_19/18/20	95 %
MEAN_BEP_20	-2.00 -- -1.84	MEAN_BEP_20/19/21	95 %
MEAN_BEP_21	-2.16 -- -2.00	MEAN_BEP_21/20/22	85 %
MEAN_BEP_22	-2.32 -- -2.16	MEAN_BEP_22/21/23	85 %
MEAN_BEP_23	-2.48 -- -2.32	MEAN_BEP_23/22/24	85 %
MEAN_BEP_24	-2.64 -- -2.48	MEAN_BEP_24/23/25	85 %
MEAN_BEP_25	-2.80 -- -2.64	MEAN_BEP_25/23/24/26/27	85 %
MEAN_BEP_26	-2.96 -- -2.80	MEAN_BEP_26/24/25/27/28	85 %
MEAN_BEP_27	-3.12 -- -2.96	MEAN_BEP_27/25/26/28/29	80 %
MEAN_BEP_28	-3.28 -- -3.12	MEAN_BEP_28/26/27/29/30	80 %
MEAN_BEP_29	-3.44 -- -3.28	MEAN_BEP_29/27/28/30/31	80 %
MEAN_BEP_30	-3.60 -- -3.44	MEAN_BEP_30/28/29/31	90 %
MEAN_BEP_31	< -3.60	MEAN_BEP_31/29/30	90 %

For a coding on 4 bits, the 4 most significant bits are used.

NOTE1: MEAN_BEP is calculated and filtered in a linear scale but mapped to a logarithmic scale for reporting.

NOTE2: The accuracy requirements above take into account possible fluctuations of the bit error rate due to adaptiveness of receivers.

NOTE3: Testing requires measurement of the actual bit error rate and assessment of MEAN_BEP reports based on the same period of time.

The mapping table for the coefficient of variation of the channel quality is defined as follows for both 8-PSK and GMSK:

CV_BEP 0	2.00	> CV_BEP >	1.75
CV_BEP 1	1.75	> CV_BEP >	1.50
CV_BEP 2	1.50	> CV_BEP >	1.25
CV_BEP 3	1.25	> CV_BEP >	1.00
CV_BEP 4	1.00	> CV_BEP >	0.75
CV_BEP 5	0.75	> CV_BEP >	0.50
CV_BEP 6	0.50	> CV_BEP >	0.25
CV_BEP 7	0.25	> CV_BEP >	0.00

The accuracy requirements for CV_BEP need not be specified since they are directly linked to those for MEAN_BEP. Nevertheless, the CV_BEP measured at the MS shall be the one used by this MS.

8.3 Aspects of discontinuous transmission (DTX)

When DTX is employed on a TCH, not all TDMA frames may be transmitted. However, the following subset shall always be transmitted, except for TCH/AFS and TCH/AHS, and hence can be employed to assess quality and signal level during DTX.

Type of channel	TDMA frame subset always to be transmitted TDMA frame number (FN) modulo 104
TCH/F	52, 53, 54, 55, 56, 57, 58, 59
TCH/HS,subchannel 0	0, 2, 4, 6, 52, 54, 56, 58
TCH/HS,subchannel 1	14, 16, 18, 20, 66, 68, 70, 72
TCH/H,data,subchannel 0,uplink	52, 54, 56, 58, 60, 62, 65, 67, 69, 71
TCH/H,data,subchannel 0,downlink	56, 58, 60, 62, 65, 67, 69, 71, 73, 75
TCH/H,data,subchannel 1,uplink	70, 72, 74, 76, 79, 81, 83, 85, 87, 89
TCH/H,data,subchannel 1,downlink	66, 68, 70, 72, 74, 76, 79, 81, 83, 85

On any TCH this subset of TDMA frames is always used for transmission during DTX. For speech, when no signalling or speech is to be transmitted these TDMA frames are occupied by the SID (Silence Descriptor) frame, see 3GPP TS 06.12 and TSM 3GPP TS 06.31 for detailed specification of the SID frame and its transmission requirements. In other cases when no information is required to be transmitted, e.g. on data channels, the L2 fill frame (see 3GPP TS 04.06 subclause 5.4.2.3) shall be transmitted as a FACCH in the TDMA frame subset always to be transmitted.

On the SDCCH and on the half rate traffic channel TCH/H in signalling only mode DTX is not allowed. In these cases and on the TCH/F in signalling only mode when DTX is not used, the same L2 fill frame shall be transmitted in case there is nothing else to transmit.

On TCH/AFS and TCH/AHS, there is no fixed subset of TDMA frames that will always be transmitted during DTX. A detection algorithm is required in the receiver which informs about whether a SID_UPDATE (see 3GPP TS 05.03 and 3GPP TS 06.93) frame was transmitted (and thus can be used for quality and signal level estimation) or not.

If no FPC commands are received during a reporting period, the SACCH power command shall be used.

8.4 Measurement reporting

8.4.1 Measurement reporting for the MS on a TCH

For a TCH, the reporting period of length 104 TDMA frames (480 ms) is defined in terms of TDMA frame numbers (FN) as follows:

Timeslot number (TN)			TDMA frame number (FN) modulo 104	
TCH/F	TCH/H,subch.0	TCH/H,subch.1	Reporting period	SACCH Message block
0	0 and 1		0 to 103	12, 38, 64, 90
1		0 and 1	13 to 12	25, 51, 77, 103
2	2 and 3		26 to 25	38, 64, 90, 12
3		2 and 3	39 to 38	51, 77, 103, 25
4	4 and 5		52 to 51	64, 90, 12, 38
5		4 and 5	65 to 64	77, 103, 25, 51
6	6 and 7		78 to 77	90, 12, 38, 64
7		6 and 7	91 to 90	103, 25, 51, 77

For a multislot configuration, the reporting period and SACCH Message block for each timeslot is defined as for TCH/F for TN = 0.

When on a TCH, the MS shall assess during the reporting period and transmit to the BSS in the next SACCH message block the following:

- RXLEV for the BCCH carrier of the 6 cells with the highest RXLEV among those with known and allowed NCC part of BSIC. For a multi band MS the number of cells, for each frequency band supported, which shall be included is specified in subclause 8.4.3. For a cell of other radio access technology, see subclauses 8.1.5 and 8.4.7.

NOTE 1: Since there are 104 TDMA frames in each SACCH multiframe (and measurement in 4 frames is optional), the number of samples on each BCCH carrier will depend on the number of carriers defined in the BCCH Allocation (BA) and may be different. The following table gives examples of this.

Number of BCCH carriers in BCCH Allocation	Number of samples per carrier in SACCH multiframe
32	3-4
16	6-7
10	10-11
8	12-13
:	:
:	:

These figures are increased if the MS is able to make measurements on more than one BCCH carrier during each TDMA frame.

- RXLEV_FULL and RXQUAL_FULL:
RXLEV and RXQUAL for the full set of TCH and SACCH TDMA frames. The full set of TDMA frames is either 100 (i.e. 104 - 4 idle) frames for a full rate TCH or 52 frames for a half-rate TCH.
- RXLEV_SUB and RXQUAL_SUB:
RXLEV and RXQUAL for the subset of 4 SACCH frames and the SID TDMA frames/ SID_UPDATE frames/L2 fill frames defined in 8.3. In case of data traffic channels TCH/F9.6, TCH/F4.8, TCH/H4.8 and TCH/H2.4, the RXQUAL_SUB report shall include measurements on the TDMA frames given in the table of subclause 8.3 only if L2 fill frames have been received as FACCH frames at the corresponding frame positions. If no FACCH frames have been received at the corresponding frame positions, the RXQUAL_SUB report shall include measurements on the 4 SACCH frames only. The performance requirements of subclause 8.2.4 do not apply in this case for RXQUAL_SUB.
In case of half rate speech channel TCH/HS, if a SID frame or a speech frame as defined in subclause 8.3 is replaced by an FACCH frame, the RXQUAL measurement on these frames shall be excluded from the RXQUAL SUB report. The performance requirements of subclause 8.2.4 do not apply in this case for RXQUAL SUB.
In case of half rate traffic channel TCH/H in signalling only mode, -SUB values are set equal to the -FULL values in the SACCH message, since DTX is not allowed in this case.
In the case of TCH/AFS or TCH/AHS, the RXLEV_SUB and RXQUAL_SUB shall take into account all detected SID_UPDATE frames in addition to the 4 SACCH frames.

NOTE 2: If measurement on the BCCH carrier is not used, the number of TDMA frames used in the RXLEV averaging process may be lower than the number of TDMA frames in the set see subclause 8.1.3.

In case of a multislot configuration, the MS shall report the following according to the definition above:

- on the main SACCH: the RXLEV values from the adjacent cells, RXLEV_FULL and RXLEV_SUB from the main channel and the worst RXQUAL_FULL values and RXQUAL_SUB values from the main channel and the unidirectional channels;
- on each other bi-directional SACCH: the RXLEV values from the adjacent cells, RXLEV_FULL, RXLEV_SUB, RXQUAL_FULL and RXQUAL_SUB from the corresponding channel.

8.4.1.1 Measurement reporting for the MS on an E-TCH in FPC mode

For an E-TCH, the FPC reporting period of length 4 TDMA frames (20 ms) is defined according to chapter 4.7,

When on an E-TCH using 8PSK for the uplink, the MS shall, in addition to what is specified in chapter 8.4.1, assess during the FPC reporting period and transmit to the BSS in the next scheduled FPC inband message (see chapter 4.7) the following:

- RXQUAL_FAST:
RXQUAL for the set of 4 TDMA frames.

8.4.2 Measurement reporting for the MS on a SDCCH

For a SDCCH, the reporting period of length 102 TDMA frames (470.8 ms) is defined in terms of TDMA frame numbers (FN) as follows:

	TDMA frame number (FN) modulo 102
SDCCH/8	12 to 11
SDCCH/4	37 to 36

NOTE 1: Some SDCCH data or TCH speech, data or SID message blocks are spread over two reporting periods. In these cases, the RXLEV and/or RXQUAL information from the SDCCH or TCH message blocks may either be sent as part of the measurement report of the second period, or shared between the reports of the two periods.

When on a SDCCH, the MS shall assess during the reporting period and transmit to the BSS in the next SACCH message block the following:

- RXLEV for the BCCH carrier of the 6 cells with the highest RXLEV among those with known and allowed NCC part of BSIC. For a multi band MS the number of cells, for each frequency band supported, which shall be included is specified in subclause 8.4.3. For a cell of other radio access technology, see subclauses 8.1.5 and 8.4.7.

NOTE 2: With only 102 TDMA frames in each SACCH multiframe, the number of samples used to calculate RXLEV per BCCH carrier may be slightly different from the case of TCH described above.

- RXLEV and RXQUAL for the full set of 12 (8 SDCCH and 4 SA CCH) frames within the reporting period. As DTX is not allowed on the SDCCH, -SUB values are set equal to the -FULL values in the SA CCH message.

NOTE 3: If measurement on the BCCH carrier is not used, the number of TDMA frames used in the RXLEV averaging process may be lower than the number of TDMA frames in the full set see subclause 8.1.3.

8.4.3 Additional cell reporting requirements for multi band MS

For a multi band MS the number of cells, for each frequency band supported, which shall be included in the measurement report is indicated by the parameter MULTIBAND_REPORTING, broadcast on BCCH and PBCCH. An MS attached to GPRS shall use the parameter broadcast on PBCCH if it exists. In all other cases, the MS shall use the parameter broadcast on BCCH. The parameter may also be sent to the MS on SACCH.

The meaning of different values of the parameter is specified as follows:

Value	Meaning
00	Normal reporting of the six strongest cells, with known and allowed NCC part of BSIC, irrespective of the band used.
01	The MS shall report the strongest cell, with known and allowed NCC part of BSIC, in each of the frequency bands in the BA list, excluding the frequency band of the serving cell. The remaining positions in the measurement report shall be used for reporting of cells in the band of the serving cell. If there are still remaining positions, these shall be used to report the next strongest identified cells in the other bands irrespective of the band used.
10	The MS shall report the two strongest cells, with known and allowed NCC part of BSIC, in each of the frequency bands in the BA list, excluding the frequency band of the serving cell. The remaining positions in the measurement report shall be used for reporting of cells in the band of the serving cell. If there are still remaining positions, these shall be used to report the next strongest identified cells in the other bands irrespective of the band used.

- 11 The MS shall report the three strongest cells, with known and allowed NCC part of BSIC, in each of the frequency bands in the BA list, excluding the frequency band of the serving cell. The remaining positions in the measurement report shall be used for reporting of cells in the band of the serving cell. If there are still remaining positions, these shall be used to report the next strongest identified cells in the other bands irrespective of the band used.

8.4.4 Common aspects for the MS on a TCH or a SDCCH

Whether the MS is on a TCH or a SDCCH, if an SACCH message block is used for a different Layer 3 message, the measurement report that would otherwise be sent in that block is discarded and a new measurement report provided for the next SACCH message.

The MS shall also transmit a bit (DTX_USED) in the next SACCH message block, which indicates whether or not it has employed DTX during the reporting period. This bit shall be set even if just one burst in a TDMA frame in the reporting period was not transmitted due to DTX.

NOTE: A speech or user data frame subject to DTX may cross the "border" between two reporting periods, in which case both of the associated SACCH message blocks will have the DTX_USED flag set.

The measurements in the MS shall be based on the current BA list and the current NCC_PERMITTED (see table 1), available at the beginning of the reporting period. At the transition from idle mode to a TCH or a SDCCH the current BA list is the BA(BCCH), later the latest received complete BA(SACCH). A complete BA(SACCH) for a MS shall be that contained in SI 5 and additionally SI 5bis if the EXT-IND bit in the Neighbour Cell Description information element in both the SI 5 and SI 5bis messages indicates that each information element only carries part of the BA. If a SI 5ter message is subsequently received and not ignored (see 3GPP TS 04.18) the BA(SACCH) shall be modified accordingly.

At the transition from idle mode to a TCH or a SDCCH the current NCC is the NCC_PERMITTED received on the BCCH, later the latest NCC_PERMITTED received on the SACCH. The measurement process on carriers contained in both lists is, therefore, continuous.

If the current BA list does not refer to the serving cell, e.g. after a handover, this shall be indicated and no measurement values for cells in the BA list shall be reported.

If the MS returns to the previous cell after a failure of the handover procedure the description above applies. As a consequence, a BA list (and/or NCC_PERMITTED) received on the SACCH in the cell to which the handover failed shall be regarded as the current ones, which may lead to interruptions in the measurement reporting as the BA list does not refer to the serving cell. As an option, the MS may in this case remember the last received BA list and NCC_PERMITTED in the old cell and regard those as the current ones when returning.

What is said in this subclause about the BA list also applies to the GSM neighbour cell list when using enhanced measurement reporting and to the 3G neighbour cell list for a multi-RAT MS. The rules for building of and changing between neighbour cell lists are defined in 3GPP TS 04.18.

8.4.5 Measurement reporting for the BSS

Unless otherwise specified by the operator, the BSS shall make the same RXLEV (full and sub) and RXQUAL (full and sub) assessments as described for the MS for all TCH's and SDCCH's assigned to an MS, using the associated reporting periods. These values, together with the reported values from the MS, shall be transmitted to the BSC as described in the 3GPP TS 08.58.

8.4.6 Extended measurement reporting

When on a TCH or SDCCH, the mobile station may receive an Extended Measurement Order (EMO) message. The mobile station shall then, during one reporting period, perform received signal level measurements according to the frequency list contained in the EMO message. BSIC decoding is not required for these frequencies. The mobile station shall then transmit the measurement results in one single Extended Measurement Report message, containing the following:

- RXLEV (as defined in subclause 8.1.4) for the carriers specified by the last received EMO message. If the EMO contains more than 21 carriers, only the 21 first carriers in the sorted EXTENDED MEASUREMENT FREQUENCY LIST (in the EMO) are measured and reported.

- DTX USED, as defined in subclause 8.4.4.

NOTE: the position of the signal strength measurement samples performed by the mobile station, and the duration of these samples are not known in a TDMA frame. Consequently, in case the signal level on the carrier the MS has to monitor is not constant, the MS will report as the RXLEV value, the signal strength measurements performed during its sampling period. This value can be different from the mean value of the signal level on the whole frame.

If reporting is not possible due to requirements to send other Layer 3 messages, the measurements shall either be discarded and new measurements scheduled at the next possible opportunity or saved and transmitted at the next possible opportunity. If extended measurements can not be reported within 10 seconds after the triggering EMO was received, they shall be discarded (and not reported).

If the EMO message contains frequencies outside the MS' frequency band, the MS shall set the corresponding RXLEV value(s) to zero.

After a successful channel change, no Extended Measurement Report shall be sent if the EMO was received before that channel change.

After having performed Extended Measurements during one reporting period, the mobile station shall resume the measurements according to the current BA list. This applies for each rescheduling of the Extended measurements.

8.4.7 Additional cell reporting requirements for multi-RAT MS

A multi-RAT MS shall report the number of best valid cells, in each supported other radio access technology/mode in the neighbour cell list, according to the value of the parameters XXX_MULTIRAT_REPORTING (XXX indicates radio access technology/mode). The remaining positions in the measurement report shall be used for reporting of GSM cells as defined in subclause 8.4.3. If there are still remaining positions, these shall be used to report the next best valid cells in other radio access technologies. The best cell is the cell with the highest reported value (see subclause 8.1.5).

If the neighbour cell list contains a UTRAN frequency for which RSSI shall be reported, that report shall be included whenever a cell on that frequency is reported (RSSI shall be reported once per frequency occurrence in the neighbouring cell list). RSSI measurements for frequencies contained in the neighbour cell list shall be reported with high priority and shall be reported before measurements on valid 3G cell, in case of not available positions.

Note: The parameter XXX_MULTIRAT_REPORTING indicates a number of cells to be reported in a measurement report message and does not include the number of places taken by RSSI reporting in the measurement report message.

If no measurements have been performed on a cell since last report, the cell shall not be included in the report.

For UTRAN FDD, valid cells are identified cells where the primary CPICH has been received when using the scrambling code provided for that frequency in the neighbour cell list.

For UTRAN TDD, valid cells are identified cells with correct cell parameter and sync case provided for that frequency in the neighbour cell list.

For cdma2000, valid cells are identified cells with correct Pilot PN sequence offset index (PILOT_PN, as defined in TIA/EIA/IS-2000-A) provided for that frequency in the neighbour cell list.

The XXX_MULTIRAT_REPORTING parameters are broadcast on BCCH and PBCCH. An MS attached to GPRS shall use the parameters broadcast on PBCCH if it exists. In all other cases, the MS shall use the parameters broadcast on BCCH. The parameters may also be sent to the MS on SACCH.

8.4.8 Enhanced Measurement Reporting

The network may request the MS to report serving cell and neighbour cell measurements with Enhanced Measurement Report message by the parameter REPORT_TYPE, provided that BSIC for all GSM neighbour cells has been sent to the MS (See 3GPP TS 04.18). This reporting is referred as Enhanced Measurement Reporting.

If Enhanced Measurement Reporting is used, the BCCH carriers and corresponding valid BSICs of the GSM neighbour cells are sent to the MS within System Information messages and MEASUREMENT INFORMATION message (See 3GPP TS 04.18). The MEASUREMENT INFORMATION message also includes the parameters SERVING_BAND_REPORTING, MULTIBAND_REPORTING, XXX_MULTIRAT_REPORTING (XXX

indicates other radio access technology/mode), XXX_REPORTING_THRESHOLD (XXX indicates GSM band or other radio access technology/mode), XXX_REPORTING_OFFSET (XXX indicates GSM band or other radio access technology/mode), REP_PRIORITY, REPORTING_RATE and INVALID_BSIC_REPORTING.

Only GSM cells with the valid BSIC shall be reported unless otherwise stated.

8.4.8.1 Reporting Priority

The MS shall include the neighbour cell measurement results using the following priority order:

- 1) the number of strongest GSM cells with known and valid BSIC and with a reported value equal or greater than XXX_REPORTING_THRESHOLD, in the frequency band of the serving cell, according to the value of the parameter SERVING_BAND_REPORTING;
- 2) the number of strongest GSM cells with known and valid BSIC and with a reported value equal or greater than XXX_REPORTING_THRESHOLD, in each of the frequency bands in the BA list, excluding the frequency band of the serving cell, according to the value of the parameter MULTIBAND_REPORTING;
- 3) the number of best valid cells and with a reported value equal or greater than XXX_REPORTING_THRESHOLD, in each supported other radio access technology/mode in the 3G neighbour cell list, according to the value of the parameters XXX_MULTIRAT_REPORTING. A valid cell is defined in subclause 8.4.7.
- 4) The remaining GSM cells with known and valid BSIC or, if indicated by the parameter INVALID_BSIC_REPORTING, with known and allowed NCC part of the BSIC in any frequency band and valid cells of other radio access technologies. Except for cells with high reporting priority as indicated with by the parameter REP_PRIORITY, these cells may be reported less frequently, if indicated by the parameter REPORTING_RATE, but at least once in four consecutive measurement reports. For those cells that are not reported in every measurement report, the MS shall average the measurements of the current and the previous reporting period (i.e. over two reporting periods).

For UTRAN FDD cells within this priority level, the reporting priority shall always be based on RSCP even if Ec/No is reported.

If the neighbour cell list contains a UTRAN frequency for which RSSI shall be reported, that report shall be included whenever a cell on that frequency is reported, as described in 8.4.7.

For each of the priority levels above, the following shall apply:

- if the number of valid cells is less than indicated the unused positions in the report shall be left for the lower prioritised cells;
- if there is not enough space in the report for all valid cells, the cells shall be reported that has the highest sum of the reported value (RXLEV or as defined in subclause 8.1.5) and the parameter XXX_REPORTING_OFFSET for respective radio access technology/mode. Note that this parameter shall not affect the actual reported value. If a cell can not be reported due to lack of space in the report, then no cell with a lower value shall be reported, even if one of these cells with a lower value would fit in the report.

8.4.8.2 Measurement Reporting

The reporting period shall be as specified in 8.4.1 for the MS on a TCH and as specified in 8.4.2 for the MS on a SDCCH.

When on a TCH, the MS shall assess during the reporting period and transmit to the BSS in the next SACCH message block the following:

- RXLEV for neighbour cells in the order defined in 8.4.8.1. For a cell of other radio access technology, see subclause 8.1.5.
- RXQUAL_FULL:
RXQUAL for the full set of TCH and SACCH TDMA frames. The full set of TDMA frames is either 100 (i.e. 104 - 4 idle) frames for a full rate TCH or 52 frames for a half-rate TCH.
- RXLEV_VAL:
RXLEV measured on SACCH frames and on the 4 last time slots of each fully received and correctly

decoded block, whether the DTX was used in downlink or not. For speech traffic channels, blocks that have not been erased, shall be considered as correctly decoded. For non-transparent data, blocks are considered as correctly decoded according the CRC received. For transparent data, all blocks are considered as correctly decoded.

- MEAN_BEP and CV_BEP:
The average over the reporting period of the Mean and Coefficient of Variation of the Bit Error Probability measures excluding CV_BEP_{block} measurements from SACCH blocks (see subclause 8.2.3).
 - NBR_RCVD_BLOCKS:
The number of correctly decoded blocks, as defined for RXLEV_VAL, (excluding all SID frames, RATSCCH, SACCH and FACCH blocks) that were completed during the measurement report period. As an exception, FACCH blocks shall be included in the case of signalling only mode.
- Note: In some cases more than one data frame needs to be received in order to identify a block as correctly decoded, e.g. for 14.4 data where one RLP frame consists of two consecutive blocks. In some cases a single block carries multiple RLP frames in which case it is sufficient that one of those RLP frames is correctly received.
- BSIC_SEEN:
Indicates if a GSM cell with invalid BSIC and allowed NCC part of the BSIC is one of the six strongest cells.

In case of a multislot configuration the MS shall report the following according to the definition above:

- on the main SACCH: the RXLEV values from the adjacent cells, BSIC_SEEN, RXLEV_VAL and NBR_RCVD_BLOCKS from the main channel, the worst RXQUAL_FULL value and the worst MEAN_BEP value from the main channel and the unidirectional channels and the CV_BEP value from the same channel as the reported MEAN_BEP;
- on each other bi-directional SACCH: the RXLEV values from the adjacent cells, BSIC_SEEN, RXLEV_VAL, NBR_RCVD_BLOCKS, RXQUAL_FULL, MEAN_BEP and CV_BEP from the corresponding channel.

When on a SDCCH, the MS shall assess during the reporting period and transmit to the BSS in the next SACCH message block the following:

- RXLEV for neighbour cells as defined in 8.4.8.1. For a cell of other radio access technology, see subclause 8.1.5.
- RXLEV_VAL, NBR_RCVD_BLOCKS, RXQUAL_FULL, MEAN_BEP and CV_BEP for the full set of 12 (8 SDCCH and 4 SACCH) TDMA frames within the reporting period. As DTX is not allowed on the SDCCH, measurements on all 12 TDMA frames shall be included for RXLEV_VAL.
- BSIC_SEEN:
Indicates if a GSM cell with invalid BSIC and allowed NCC part of the BSIC is one of the six strongest cells.

The common aspects for the MS on a TCH or a SDCCH as defined in 8.4.4 shall apply.

8.5 Absolute MS-BTS distance

8.5.1 General

The Absolute MS-BTS distance may be employed by the network as a criterion in the handover processes.

8.5.2 Physical parameter

The information being used by the BSS to perform "adaptive frame alignment" (3GPP TS 05.10) in the MS is a representation of the absolute distance of the MS to the serving BTS.

This absolute distance may be used by the BSS to prevent MS from grossly exceeding the planned cell boundaries.

The allowable distance is administered on a cell by cell basis by the network operator.

9 Control parameters

The parameters employed to control the radio links are shown in tables 1 and 2.

Table 1: Radio sub-system link control parameters

Parameter name	Description	Range	Bits	Channel
BSIC	Base station Identification Code	0-63	6	SCH D/L
BA	BCCH Allocation	-	-	BCCH D/L
BA_IND	Sequence number of BA	0/1	1	BCCH D/L
MS_TXPWR_MAX_CCH	The maximum TX power level an MS may use when accessing the system until otherwise commanded.	0/31	5	BCCH D/L
POWER_OFFSET	The power offset will be used in conjunction with the MS TXPWR_MAX_CCH parameter by the class 3 DCS 1 800 MS: 0 = 0 dB 1 = 2 dB 2 = 4 dB 3 = 6 dB	0-3	2	BCCH D/L
RXLEV_ACCESS_MIN	Minimum received signal level at the MS required for access to the system.	0-63	6	BCCH D/L
RADIO_LINK_TIMEOUT	The maximum value of the radio link counter 4-64 SACCH blocks, 15 steps of 4 SACCH blocks	-	4	BCCH D/L SACCH D/L
CELL_RESELECT_HYSTERESIS	RXLEV hysteresis for required cell re-selection. 0-14 dB, 2 dB steps, i.e. 0 = 0 dB, 1 = 2 dB, etc.	0-7	3	BCCH D/L
NCC_PERMITTED	Bit map of NCCs for which the MS is permitted to report measurement results. Bit map relates to NCC part of BSIC.	-	8	BCCH D/L SACCH D/L
CELL_BAR_ACCESS	See table 1a.	0/1	1	BCCH D/L
CELL_BAR_QUALIFY	See table 1a	0/1	1	BCCH D/L
CELL_RESELECT_OFFSET	Applies an offset to the C2 reselection criterion. 0 - 126 dB, 2 dB steps, i.e. 0 = 0 dB, 1 = 2 dB, etc.	0-63	6	BCCH D/L
TEMPORARY_OFFSET	Applies a negative offset to C2 for the duration of PENALTY_TIME. 0 - 60 dB, 10 dB steps i.e. 0 = 0 dB, 1 = 10 dB, etc. and 7 = infinity	0-7	3	BCCH D/L
PENALTY_TIME	Gives the duration for which the temporary offset is applied. 20 to 620 s, 20 s steps, i.e. 0 = 20 s, 1 = 40 s, etc. 31 is reserved to indicate that CELL_RESELECT_OFFSET is subtracted from C2 and TEMPORARY_OFFSET is ignored.	0-31	5	BCCH D/L
LSA_OFFSET	Applies an offset to be used for LSA cell re-selection between cells with the same LSA priorities. 0 = 0 dB, 1 = 4 dB, 2 = 8 dB, 3 = 16 dB, 4 = 24 dB, 5 = 32 dB, 6 = 48 dB, 7 = 64 dB	0-7	3	BCCH D/L
PRIO_THR	The PRIO signal strength threshold is related to RXLEV_ACCESS_MIN. 0 = 0 dB, 1 = 6 dB, 2 = 12 dB, 3 = 18 dB 4 = 24 dB, 5 = 30 dB, 6 = 36 dB, 7 = ∞ dB	0-7	3	BCCH D/L
LSA_ID	The LSA identities for the cell			BCCH D/L
Qsearch_I	Search for 3G cells if signal level is below (0-7) or above (8-15) threshold 0 = - 98 dBm, 1 = - 94 dBm, ... , 6 = - 74 dBm, 7 = ∞ (always) 8 = - 78 dBm, 9 = - 74 dBm, ... , 14 = - 54 dBm, 15 = ∞ (never). Default value = ∞ (never).	0-15	4	BCCH D/L

Qsearch_C_Initial	Indicates the Qsearch value to be used in connected mode before Qsearch_C is received, 0 = use Qsearch_I, 1 = ∞ (always). Default value = use Qsearch_I.	0/1	1	BCCH D/L
XXX_Qoffset	Applies an offset to RLA_C for cell re-selection to access technology/mode XXX (one or more) 0 = -∞ (always select a cell if acceptable), 1 = -28 dB, 2 = -24 dB, ... , 15 = 28 dB. Default value = 0 dB.	0-15	4	BCCH D/L
FDD_Qmin	A minimum threshold for Ec/No for UTRAN FDD cell re-selection, 0= -20dB, 1= -6dB, 2= -18dB, 3= -8dB, 4= -16dB, 5= -10dB, 6= -14dB, 7= -12dB. Default value= -12dB.	0-7	3	BCCH D/L

Table 1a: Parameters affecting cell priority for cell selection

CELL_BAR QUALIFY	CELL_BAR ACCESS	Cell selection priority	Status for cell reselection
0	0	normal	normal
0	1	barred	barred
1	0	low	normal (see note 2)
1	1	low	normal (see note 2)

If all the following conditions are met, then the "Cell selection priority" and the "Status for cell reselection" shall be set to normal:

- the cell belongs to the MS HPLMN;
- the MS is in cell test operation mode;
- the CELL_BAR_ACCESS is set to "1";
- the CELL_BAR_QUALIFY is set to "0";
- the Access Control class 15 is barred.

NOTE 1: A low priority cell is only selected if there are no suitable cells of normal priority (see 3GPP TS 03.22).

NOTE 2: Two identical semantics are used for cross phase compatibility reasons. This allows an operator to declare a cell always as a low priority one for a phase 2 MS, but keeps the opportunity for an operator to decide whether a phase 1 MS is permitted to camp on such a cell or not.

Table 2: Handover and power control parameters - slow ACCH

Parameter name	Description	Range	Bits	Message
MS_TXPWR_REQUEST (ordered MS power level)	The power level to be used by an MS	0-31	5	L1 header downlink
MS_TXPWR_CONF. (actual MS power level)	Indication of the power level in use by the MS.	0-31	5	L1 header uplink
POWER_LEVEL	The power level to be used by an MS on the indicated channel	0-31	5	HO/assignment command
RXLEV_FULL_SERVING_CELL	The RXLEV in the current serving cell accessed over all TDMA frames	0-63	6	Measurement results
RXLEV_SUB_SERVING_CELL	The RXLEV in the current serving cell accessed over a subset of TDMA frames	0-63	6	Measurement results
RXQUAL_FULL_SERVING_CELL	The RXQUAL in the current serving cell, assessed over all TDMA frames.	0-7	3	Measurement results
RXQUAL_SUB_SERVING_CELL	The RXQUAL in the current serving a cell, assessed over subset of TDMA frames.	0-7	3	Measurement results
DTX_USED	Indicates whether or not the MS used DTX during the previous measurement period.	-	1	Measurement results
BA_USED	Value of BA_IND for BCCH allocation used	0/1	1	Measurement results
RXLEV_NCELL_(1-6)	The RXLEV assessed on BCCH carrier as indicated in the BCCH Allocation	0-63	6	Measurement results
BCCH_FREQ_NCELL_(1-6)	The BCCH carrier RF channel number in NCELL.	0-31	5	Measurement results
BSIC_NCELL_(1-6)	Base station identification code for NCELL.	0-63	6	Measurement results
MULTIBAND_REPORTING	Indication of the number of cells to be reported for each band in multiband operation.	0-3	2	BCCH D/L SACCH D/L
SCALE	Indication of the offset, which applies for the reported RXLEV values. 0 = 0 dB, 1 = +10 dB	0-1	1	Enhanced Measurement Report
SCALE_ORD	Indication of the offset, which shall be used for the reported RXLEV values. 0 = +0 dB, 1 = + 10 dB, 2 = automatic Default value = 0 dB.	0-2	2	SACCH D/L
Qsearch_C	Search for 3G cells if signal level below threshold (0-7): - 98, - 94, ... , - 74 dBm, ∞ (always) or above threshold (8-15): - 78, - 74, ... , - 54 dBm, ∞ (never)	0-15	4	SACCH D/L
REPORT_TYPE	Indicates which report type the MS shall use, 0 = enhanced, 1 = normal Default value = normal	0/1	1	BCCH D/L SACCH D/L
XXX_MULTIRAT_REPORTING	The number of cells from the access technology/mode XXX (one or more) that shall be included in the list of strongest cells or in the measurement report.	0-3	2	BCCH D/L SACCH D/L
SERVING_BAND_REPORTING	The number of cells from the GSM serving frequency band that shall be included in the list of strongest cells or in the measurement report. Default value = 3	0-3	2	BCCH D/L SACCH D/L
REP_PRIORITY	Indicates the reporting priority per cell, 0 = normal, 1 = high Default value = normal	0/1	1	SACCH D/L
REPORTING_RATE	Indicates the allowed reporting rate, 0 = normal, 1 = reduced Default value = normal.	0/1	1	SACCH D/L

INVALID_BSIC_REPORTING	Indicates if GSM cells with invalid BSIC and allowed NCC part may be reported, 0 = no, 1 = yes Default value = no.	0/1	1	SACCH D/L
XXX_REPORTING_THRESHOLD	Apply priority reporting if the reported value is above threshold for GSM frequency band or access technology/mode XXX (one or more), 0, 6, ... , 36, ∞ (never). Default value = always.	0-7	3	SACCH D/L
XXX_REPORTING_OFFSET	Apply an offset to the reported value when prioritising the cells for reporting for GSM frequency band or access technology/mode XXX (one or more), 0, 6, ... , 42 dB. Default value = 0 dB.	0-7	3	SACCH D/L
FDD_REP_QUANT	Indicates the reporting quantity for UTRAN FDD cells, 0 = RSCP, 1 = Ec/No	0/1	1	BCCH D/L SACCH D/L
3G_SEARCH_PRIO	Indicates if 3G cells may be searched when BSIC decoding is required, 0 = no, 1 = yes Default value = yes	0/1	1	SACCH D/L
RTD	The real time difference to other GSM cells, modulo 51 TDMA frames, step: 1 or 1/64 TDMA frame	0-50 or 0-3263	6 or 12	SACCH D/L
NOTE 1: RXLEV and RXQUAL fields are coded as described in clause 8. NOTE 2: BCCH_FREQ_NCELL_(1-6) is coded in accordance with 3GPP TS 04.18 as the position in the list of BA carriers. NOTE 3: For the details of the Measurement Result message see 3GPP TS 04.18.				

10 GPRS mode tasks

10.1 Cell Re-selection

In GPRS Standby and Ready states, cell re-selection is performed by the MS, except for a class A MS (see 3GPP TS 02.06) while in dedicated mode of a circuit switched connection, in which case the cell is determined by the network according to the handover procedures (see subclause 3). When the circuit switched connection is released, the MS shall resume cell re-selection (see subclause 6.7.1).

The cell re-selection procedures defined in subclauses 10.1.1 to 10.1.3 apply to the MSs attached to GPRS if a PBCCH exists in the serving cell.

If PBCCH does not exist, the criteria and algorithms defined in subclauses 10.1.2 and 10.1.3 shall also apply if GPRS cell re-selection parameters for one or more cells are provided to the MS in a Packet Cell Change Order or Packet Measurement Order message (see 04.60). In this case, the MS shall convert the idle mode cell re-selection parameters, received for the other cells according to clause 6, to GPRS cell re-selection parameters according to table 3a and use the same procedures, except that the MS may measure received signal strength in packet idle mode according to either subclause 6.6.1 or subclause 10.1.1.

Otherwise the MS shall perform cell re-selection according to the idle mode procedures defined in clause 6, except that the MS is only required to monitor full system information on BCCH of the serving cell if indicated by change mark on BCCH or PACCH. If PBCCH exists, the MS is not required to monitor system information on BCCH of the serving cell or any system information of the non-serving cells and only required to monitor system information on PBCCH of the serving cell if indicated by change mark on PBCCH, PCCCH or PACCH.

For both cases (with or without PBCCH), the details of system information monitoring are specified in 3GPP TS 04.60.

In packet transfer mode, the MS shall always measure received signal strength according to subclause 10.1.1.

In addition, the network may control the cell selection as defined in subclause 10.1.4.

The cells to be monitored for cell re-selection are defined in the BA(GPRS) list, which is broadcast on PBCCH. If PBCCH does not exist, BA(GPRS) is equal to BA(BCCH).

For a multi-RAT MS, cell re-selection to other radio access technologies shall also be possible. If PBCCH exists, the procedures in subclause 10.1.1.3 and 10.1.3.2 shall apply. Otherwise the idle mode procedures in subclause 6 shall apply.

10.1.1 Monitoring the received signal level and PBCCH data

The MS shall measure the received RF signal level on the BCCH carriers of the serving cell and the surrounding cells as indicated in the BA(GPRS) list and optionally the NC_FREQUENCY_LIST, and calculate the received level average (RLA_P) for each carrier.

In addition the MS shall verify the BSIC of the BCCH carriers. Only cells with allowed BSIC shall be considered for re-selection. The allowed BSIC is either a valid BSIC or, for cells in BA(BCCH) where no BSIC is broadcast, a BSIC with allowed NCC part (see subclause 7.2). A valid BSIC is a BSIC broadcast for that carrier in the BA(GPRS) list.

In addition to what is described in subclauses 10.1.1.1 and 10.1.1.2, an MS supporting SoLSA with SoLSA subscription shall attempt to decode BSIC for the 6 strongest carriers, with LSA IDs to which the MS subscribes. At least one carrier shall be searched every 5 minutes, one after another. In the case the MS has been able to decode the BSIC, the rules described in 10.1.3 shall be followed. The LSA IDs of the carriers are broadcast on PBCCH of the serving cell.

10.1.1.1 Packet idle mode

Whilst in packet idle mode (see 03.64) an MS shall continuously monitor all BCCH carriers as indicated by the BA(GPRS) list and the BCCH carrier of the serving cell. At least one received signal level measurement sample on each BCCH carrier shall be taken for each paging block monitored by the MS according to its current DRX mode and its paging group. As the minimum MS shall take one measurement for each BCCH carrier for every 4 second. As the maximum, the MS is however not required to take more than 1 sample per second for each BCCH carrier.

RLA_P shall be a running average determined using samples collected over a period of 5 s to Max {5s, five consecutive paging blocks of that MS}, and shall be maintained for each BCCH carrier. The same number of measurement samples shall be taken for all BCCH carriers, and the samples allocated to each carrier shall as far as possible be uniformly distributed over the evaluation period. At least 5 received signal level measurement samples are required for a valid RLA_P value.

The list of the 6 strongest non-serving carriers shall be updated at a rate of at least once per running average period.

The MS shall attempt to check the BSIC for each of the 6 strongest non-serving cell BCCH carriers at least every 14 consecutive paging blocks of that MS or 10 seconds, whichever is greater. If a change of BSIC is detected then the carrier shall be treated as a new carrier.

In the case of a multiband MS, the MS shall attempt to decode the BSIC, if any BCCH carrier with unknown BSIC is detected among the number of strongest BCCH carriers in each band as indicated by the parameter MULTIBAND_REPORTING (see subclause 8.4.3), broadcast on PBCCH, or if PBCCH does not exist, on BCCH.

When requested by the user, the MS shall determine which PLMNs are available as described in subclause 6.6.1. However, for MSs without DRX or with short DRX period (see 3GPP TS 05.02), considerable interruptions to the monitoring of PPCH or PCH can not be avoided.

10.1.1.2 Packet transfer mode

Whilst in packet transfer mode an MS shall continuously monitor all BCCH carriers as indicated by the BA(GPRS) list and the BCCH carrier of the serving cell. In every TDMA frame, a received signal level measurement sample shall be taken on at least one of the BCCH carriers, one after the another. Optionally, measurements during up to 8 TDMA frames per PDCH multiframe may be omitted if required for BSIC decoding or multi-RAT measurements.

RLA_P shall be a running average determined using samples collected over a period of 5 s, and shall be maintained for each BCCH carrier. The same number of measurement samples shall be taken for all BCCH carriers except, if the parameter PC_MEAS_CHAN indicates that the power control measurements shall be made on BCCH (see subclause 10.2.3.1.2), for the serving cell where at least 6 measurement samples shall be taken per 52-multiframe.

The samples allocated to each carrier shall as far as possible be uniformly distributed over the evaluation period. At least 5 received signal level measurement samples are required for a valid RLA_P value.

In some allowed multislot configurations (see 3GPP TS 05.02) the MS is not able to perform normal received signal level measurements within the TDMA frame. In this case, the MS shall perform the measurements whenever possible according to its measurement capability (see 3GPP TS 05.02). For downlink packet transfer using any medium access mode (see 3GPP TS 04.60), the MS shall perform the measurements during the block period where the polling response is sent (T_{ra} shall apply). For downlink or uplink packet transfer using fixed allocation medium access mode, the MS shall perform the measurements during inactivity periods defined by the assignment command (MEASUREMENT_MAPPING or ALLOCATION_BITMAP respectively, see 3GPP TS 04.60).

NOTE 1: The network is responsible for providing the necessary opportunities to ensure that the MS will perform the required number of measurements.

The MS shall attempt to check the BSIC for as many non-serving cell BCCH carriers as possible and as often as possible, and at least every 10 seconds. A multi-RAT MS is allowed to extend this period to 13 seconds, if the neighbour cell list contains cells from other RATs and if indicated by the parameter 3G_SEARCH_PRIO. The MS shall use the two Idle frames of the PDCH multiframe for this purpose. These frames are termed "search" frames. A list containing BSIC and timing information for these strongest carriers at the accuracy required for accessing a cell (see 3GPP TS 05.10) including the absolute times derived from the parameters T1, T2, T3 shall be kept by the MS. This information may be used to schedule the decoding of BSIC and shall be used when re-selecting a new cell in order to keep the switching time at a minimum. When a BCCH carrier is found to be no longer among the reported, BSIC and timing information shall be retained for 10 seconds. (This is in case a cell re-selection command to this cell is received just after the MS has stopped reporting that cell, see subclause 10.1.4.2).

In some allowed multislot configurations (see 3GPP TS 05.02) the MS is not able to perform BSIC decoding or multi-RAT measurements. In this case, the MS may delay the requesting of uplink packet resources, skip the last transmission burst in the frame immediately preceding the idle frame or not receive some allocated downlink packet resources in order to comply to the requirement to search, verify and decode BSIC information, or in order to perform multi-RAT measurements.

If, after averaging measurement results over 4 PDCH multiframe (1 sec), the MS detects one or more BCCH carriers, among the 6 strongest, whose BSICs are not currently being assessed, then the MS shall as a matter of priority attempt to decode their BSICs.

In the case of a multiband MS, the MS shall attempt to decode the BSIC, if any BCCH carrier with unknown BSIC is detected among the number of strongest BCCH carriers in each band as indicated by the parameter MULTIBAND_REPORTING (see subclause 8.4.3), broadcast on PBCCH, or if PBCCH does not exist, on BCCH.

Thus an MS shall, for a period of up to 5 seconds, devote all search frames to attempting to decode these BSICs. If this fails then the MS shall return to confirming existing BSICs. Having re-confirmed existing BSICs, if there are still BCCH carriers, among the six strongest, with unknown BSICs, then the decoding of these shall again be given priority for a further period of up to 5 seconds.

The MS shall be able to send the first packet random access (PRACH) at the latest $5+x$ seconds after a new strongest cell (which is part of the BA(GPRS)) has been activated under the following network conditions: Initial serving cell at RXLEV= -70 dBm, with 6 neighbours at RXLEV= -75 dBm. Then the new BCCH carrier is switched on at RXLEV= -60 dBm. x is the longest time it may take to receive the necessary system information on PBCCH in the new cell.

Note: Because of test equipment limitations it is acceptable to activate the new carrier to replace one of the 6 neighbours.

If either no BSIC can be decoded on a surrounding cell BCCH carrier, or the BSIC is not allowed, then the received signal level measurements on that channel shall be discarded and the MS shall continue to monitor that channel.

If a change of BSIC is detected on a carrier, then any existing received signal level measurement shall be discarded and the carrier shall be treated as a new carrier.

If the BSIC cannot be decoded at the next available opportunities re-attempts shall be made to decode this BSIC. If the BSIC is not decoded for more than three successive attempts it will be considered lost and any existing received signal level measurement shall be discarded and the MS shall continue to monitor that carrier.

When PBCCH is not present in the serving cell and the network controlled cell reselection mode (see subclause 10.1.4) is not set to NC2, the MS shall attempt to decode the BCCH data block that contains the parameters affecting cell reselection for each of the strongest surrounding cell BCCH carriers for which BSIC has been decoded

and is allowed, and for which cell selection parameters have not been provided in a Packet Measurement Order, Packet Cell Change Order or Packet System Information message, at least every 5 minutes. When the MS recognizes that a new carrier which meets these criteria has become one of the strongest, the BCCH data shall be decoded for the new carrier within 30 seconds.

10.1.1.3 Monitoring cells of other radio access technologies

For a multi-RAT MS, cells or frequencies with other radio access technologies may also be included in the GPRS 3G Cell Reselection list to be monitored (see 3GPP TS 04.60). This list may be modified by Packet Measurement Order or Packet Cell Change Order messages (see 3GPP TS 04.60). The network controls the measurements for reselection of those cells by the parameter Qsearch_P broadcast on PBCCH. Qsearch_P defines a threshold and also indicates whether these measurements shall be performed when RLA_P of the serving cell is below or above the threshold.

For this monitoring, the MS may use search frames that are not required for BSIC decoding or interference measurements in packet transfer mode. If indicated by the parameter 3G_SEARCH_PRIO, the MS may use up to 25 search frames per 13 seconds without considering the need for BSIC decoding or packet transfer mode interference measurements in these frames.

Both valid cells as defined in subclause 8.4.7, and any identified cell on a frequency for which not full identification is included in the GPRS 3G Cell Reselection list, shall be considered for re-selection.

In packet transfer mode, the MS shall be able to send the first access at the latest 10+x seconds after a new best UTRAN cell, which is part of the GPRS 3G Cell Reselection list, has been activated under the condition that there is only one UTRAN frequency in the list and that no new GSM cells are activated at the same time and under good radio conditions. x is the longest time it may take to receive the necessary system information in the new cell. For test purposes the following radio conditions can be used: Serving GSM cell at RXLEV= -70 dBm, with 6 GSM neighbours at RXLEV= -75 dBm. Then either an UTRAN FDD neighbour cell or an UTRAN TDD neighbour cell is switched on. The radio conditions for the UTRAN FDD cell are as follows (see TS 25.101 for definitions):

Parameter	Unit	UTRAN FDD Cell
<i>CPICH_Ec/Ior</i>	dB	-10
<i>PCCPCH_Ec/Ior</i>	dB	-12
<i>SCH_Ec/Ior</i>	dB	-12
<i>PICH_Ec/Ior</i>	dB	-15
<i>DPCH_Ec/Ior</i>	dB	$-\infty$
<i>OCNS</i>		-0.94
\hat{I}_{or}/I_{oc}	dB	10
<i>I_{oc}</i>	dBm/3.84 MHz	-70
<i>CPICH_Ec/Io</i>	dB	-10.4
<i>CPICH_RSCP</i>	dBm	-70
FDD_GPRS_Qoffset	integer	5 (-12dB)
FDD_Qmin	integer	7 (-12 dB)
Qsearch_P	integer	7 (search always)
3G_SEARCH_PRIO	integer	1
Propagation Condition	AWGN	

The radio conditions for the UTRAN TDD cell (3.84 Mcps) are as follows (see 3GPP TS 25.123 for definitions and for the values of the remaining configuration parameters):

Parameter	Unit	UTRA TDD Cell (3.84 Mcps)	
<i>Timeslot Number</i>		0	8
<i>P-CCPCH_{Ec/Ior}</i>	dB	-3	
<i>SCH_{Ec/Ior}</i>	dB	-9	-9
<i>SCH_{t_offset}</i>	integer	0	0
<i>PICH_{Ec/Ior}</i>	dB		-3
<i>OCNS_{Ec/Ior}</i>	dB	-3.12	-3.12
<i>PCCPCH RSCP</i>	dBm	-70	-70
<i>TDD_{Qoffset}</i>	integer	5 (-12 dB)	
<i>Qsearch_P</i>	integer	7 (search always)	
<i>3G_SEARCH_PRIO</i>	integer	1	
Propagation Condition	AWGN		

NOTE: On timeslot 8 the P-CCPCH is not transmitted; on that timeslot, the PCCPCH RSCP defines the power level of the beacon channel.

The allowed access time is increased by 5 seconds for each additional UTRAN frequency in the GPRS 3G Cell Reselection list and by the time required for BSIC decoding of new activated GSM cells. However, multiple UTRAN cells on the same frequency in the list does not increase the allowed access time.

In packet transfer mode, for some allowed multislot allocations (see 3GPP TS 05.02), identification of a TDD cell may not be guaranteed. In such cases, the MS may not be able to fulfil the requirement above. If after 5 seconds the MS has not been able to identify a TDD cell, the MS is allowed to stop searching for it in the current GSM cell.

In packet idle mode, the MS shall be able to identify and select a new best UTRAN cell on a frequency, which is part of the GPRS 3G Cell Reselection list, within 30 seconds after it has been activated under the condition that there is only one UTRAN frequency in the list and under good radio conditions. For test purposes the same radio conditions as for packet transfer can be used. The allowed time is increased by 30 seconds for each additional UTRAN frequency in the GPRS 3G Cell Reselection list. However, multiple UTRAN cells on the same frequency in the list does not increase the allowed time.

A multi-RAT MS shall be able to monitor 64 UTRAN cells, divided into (depending on the MS capability):

- FDD cells on up to 3 FDD frequencies, with a maximum of 32 cells per frequency; and/or
- TDD cells on up to 3 TDD frequencies, with a maximum of 32 cells per frequency.

In packet idle mode, the MS shall attempt to read and store UTRAN predefined configurations as specified for idle mode in subclause 6.6.4.

10.1.2 Cell Re-selection Criteria

The following cell re-selection criteria are used for GPRS, whereby (s) denotes the serving cell, and (n_i) denotes the neighbour cells. Different parameter values may apply for each neighbour cell. One set of parameters is broadcast in each cell.

- 1) The path loss criterion parameter C1 is used as a minimum signal level criterion for cell re-selection for GPRS in the same way as for GSM Idle mode. C1 is the same as defined in subclause 6.4, except that

$$A = RLA_P - GPRS_RXLEV_ACCESS_MIN$$

$$B = GPRS_MS_TXPWR_MAX_CCH - P$$

The GPRS specific parameters GPRS_RXLEV_ACCESS_MIN and GPRS_MS_TXPWR_MAX_CCH for the serving cell and neighbour cells are broadcast on PBCCH of the serving cell (POWER OFFSET is not used).

- 2) The signal level threshold criterion parameter C31 for hierarchical cell structures (HCS) is used to determine whether prioritised hierarchical GPRS and LSA cell re-selection shall apply and is defined by:

$$C31(s) = RLA_P(s) - HCS_THR(s) \quad (\text{serving cell})$$

$$C31(n) = RLA_P(n) - HCS_THR(n) - TO(n) * L(n) \quad (\text{neighbour cell})$$

where HCS_THR is the signal threshold for applying HCS GPRS and LSA re-selection. HCS_THR is broadcast on PBCCH of the serving cell.

- 3) The cell ranking criterion parameter (C32) is used to select cells among those with the same priority and is defined by:

$$C32(s) = C1(s) \quad \text{(serving cell)}$$

$$C32(n) = C1(n) + GPRS_RESELECT_OFFSET(n) - TO(n) * (1-L(n)) \quad \text{(neighbour cell)}$$

where

GPRS_RESELECT_OFFSET applies an offset and hysteresis value to each cell

$$TO(n) = GPRS_TEMPORARY_OFFSET(n) * H(GPRS_PENALTY_TIME(n) - T(n)).$$

$$L(n) = \begin{cases} 0 & \text{if PRIORITY_CLASS}(n) = \text{PRIORITY_CLASS}(s) \\ 1 & \text{if PRIORITY_CLASS}(n) \neq \text{PRIORITY_CLASS}(s) \end{cases}$$

$$H(x) = \begin{cases} 0 & \text{for } x < 0 \\ 1 & \text{for } x \geq 0 \end{cases}$$

GPRS_TEMPORARY_OFFSET applies a negative offset to C31/C32 for the duration of GPRS_PENALTY_TIME after the timer T has started for that cell. T is defined in subclause 6.4.

GPRS_RESELECT_OFFSET, PRIORITY_CLASS, GPRS_TEMPORARY_OFFSET and GPRS_PENALTY_TIME are broadcast on PBCCH of the serving cell.

10.1.3 Cell Re-selection Algorithm

At least for every new sample or every second, whichever is the greatest, the MS shall update RLA_P and calculate the value of C1, C31 and C32 for the serving cell and the non-serving cells. The MS shall make a cell re-selection if:

- i) The path loss criterion parameter (C1) for the serving cell falls below zero.
- ii) A non-serving suitable cell (see 3GPP TS 03.22) is evaluated to be better than the serving cell. The best cell is the cell with the highest value of C32 among
 - those cells that have the highest PRIORITY_CLASS among those cells that have highest LSA priority among those that fulfil the criterion $C31 \geq 0$, or
 - all cells, if no cells fulfil the criterion $C31 \geq 0$.

If the parameter C32_QUAL is set, positive GPRS_RESELECT_OFFSET values shall only be applied to the neighbour cell with the highest RLA_P value of those cells for which C32 is compared above.

LSA priority is defined by the list of LSAs for the subscriber stored on the SIM (see 3GPP TS 11.11). Cells with no LSA priority, e.g. non-LSA cells, are given LSA priority lower than 0. The LSA priority and LSA ID(s) shall be considered only by an MS supporting SoLSA.

PRIORITY_CLASS, LSA ID(s) and C32_QUAL are broadcast on PBCCH of the serving cell.

When evaluating the best cell, the following hysteresis values shall be subtracted from the C32 value for the neighbour cells:

- in standby state, if the new cell is in the same routing area: 0.
- in ready state, if the new cell is in the same routing area:
 - GPRS_CELL_RESELECT_HYSTERESIS. If the parameter C31_HYST is set, GPRS_CELL_RESELECT_HYSTERESIS shall also be subtracted from the C31 value for the neighbour cells.
- in standby or ready state, if the new cell is in a different routing area:
 - RA_RESELECT_HYSTERESIS.
- in case of a cell re-selection occurred within the previous 15 seconds: 5 dB.

GPRS_CELL_RESELECT_HYSTERESIS, C31_HYST and RA_RESELECT_HYSTERESIS are broadcast on PBCCH of the serving cell.

Cell re-selection for any other reason (see 3GPP TS 03.22) shall take place immediately, but the cell that the MS was camped on shall not be returned to within 5 seconds if another suitable cell can be found. If valid RLA_P values are not available, the MS shall wait until these values are available and then perform the cell re-selection if it is still required. The MS may accelerate the measurement procedure within the requirements in subclause 10.1.1 to minimise the cell re-selection delay.

If no suitable cell is found within 10 seconds, the cell selection algorithm of 3GPP TS 03.22 shall be performed. Since information concerning a number of channels is already known to the MS, it may assign high priority to measurements on the strongest carriers from which it has not previously made attempts to obtain BCCH information, and omit repeated measurements on the known ones.

10.1.3.1 Abnormal cell reselection

In the event of an abnormal release with cell reselection (see 3GPP TS 04.60) when PBCCH exists, an abnormal cell reselection based on BA(GPRS) shall be attempted. The MS shall perform the following algorithm to determine which cell to be used for this cell reselection attempt.

If access to another cell is not allowed, i.e. RANDOM_ACCESS_RETRY bit is not set on the serving cell:

- i) The abnormal cell reselection attempt shall be abandoned, and the algorithm of subclause 10.1.3 shall be performed.

If access to another cell is allowed, i.e. RANDOM_ACCESS_RETRY bit is set on the serving cell:

- i) The received level measurement samples taken on the carriers indicated in the BA (GPRS) received on the serving cell in the last 5 seconds shall be averaged, and the carrier with the highest received level average (RLA) with permitted BSIC, i.e. the same as broadcast together with BA (GPRS), (see subclause 10.1.1), shall be taken.
- ii) On this carrier the MS shall attempt to decode the PBCCH data block containing the parameters affecting cell selection.
- iii) If the cell is suitable (see 3GPP TS 03.22), abnormal cell reselection shall be attempted on this cell.
- iv) If the MS is unable to decode the PBCCH data block or if the conditions in iii) are not met, the carrier with the next highest received level average (RLA) with permitted BSIC shall be taken, and the MS shall repeat steps ii) and iii) above.
- v) If the cells with the 6 strongest received level average (RLA) values with permitted BSICs have been tried but cannot be used, the abnormal cell reselection attempt shall be abandoned, and the algorithm of subclause 10.1.3 shall be performed.

The MS is under no circumstances allowed to access a cell to attempt abnormal cell reselection later than 20 seconds after the detection within the MS of the abnormal release causing the abnormal cell reselection attempt. In the case where the 20 seconds elapses without a successful abnormal cell reselection the attempt shall be abandoned, and the algorithm of subclause 10.1.3 shall be performed.

In the event of an abnormal release with cell reselection (see 3GPP TS 04.60) when only BCCH exists, the MS shall only perform the algorithm of subclause 10.1.3.

10.1.3.2 Algorithm for cell re-selection from GSM to UTRAN

If the GPRS 3G Cell Reselection list includes UTRAN frequencies, the MS shall, at least every 5 second update the value RLA_P for the serving cell and each of the at least 6 strongest non-serving GSM cells.

The MS shall then reselect a suitable (see TS 25.304) UTRAN cell if:

- for a TDD cell the measured RSCP value exceeds the value of RLA_P for the serving cell and all of the suitable (see 3GPP TS 03.22) non-serving GSM cells by the value XXX_GPRS_Qoffset for a period of 5 s and
- for an FDD cell the following criteria are all met for a period of 5 s:
 1. its measured RSCP value exceeds the value of RLA_P for the serving cell and all of the suitable (see 3GPP TS 03.22) non-serving GSM cells by the value XXX_GPRS_Qoffset,

2. its measured E_c/N_0 value is equal or greater than the value FDD_Q_{min} , and
3. its measured RSCP value is equal to or greater than $FDD_RSCP_threshold$, if supported by the MS.

In case of a cell reselection occurring within the previous 15 seconds, $XXX_GPRS_Q_{offset}$ is increased by 5 dB.

where

- E_c/N_0 and RSCP are the measured quantities, see subclause 8.1.5.
- $FDD_RSCP_threshold$ equals $Q_{rxlevmin} + P_{compensation} + 10$ dB, if these parameters are available, otherwise $-\infty$ (criterion not effective).
- $Q_{rxlevmin}$ is the minimum required RX level in the UTRAN FDD cell (dBm), see 3GPP TS 25.304.
- $P_{compensation}$ is $\max(UE_TXPWR_MAX_RACH - P_MAX, 0)$ (dB), see 3GPP TS 25.304.
- $UE_TXPWR_MAX_RACH$ is the maximum TX power level an MS may use when accessing the UTRAN FDD cell on RACH (dBm), see 3GPP TS 25.304.
- P_MAX is the maximum RF output power of the MS (dBm) in UTRAN FDD mode, see 3GPP TS 25.304.
- FDD_Q_{min} and $XXX_GPRS_Q_{offset}$ are broadcast on PBCCH of the serving cell. XXX indicates other radio access technology/mode.

Note: The parameters required to determine if the UTRAN cell is suitable are broadcast on BCCH of the UTRAN cell.

The MS may store the UTRAN cell RSCP suitability criterion parameters above, whenever decoded from a UTRAN FDD cell of an equivalent PLMN. The most recently decoded parameters are valid reselection criteria towards all UTRAN FDD cells. This list of parameters shall be cleared after PLMN selection (see 3GPP TS 23.122).

Cell reselection to UTRAN shall not occur within 5 seconds after the MS has reselected a GSM cell from an UTRAN cell if a suitable GSM cell can be found.

If more than one UTRAN cell fulfils the above criteria, the MS shall select the cell with the greatest RSCP value.

10.1.4 Network controlled Cell re-selection

The network may request measurement reports from the MS and control its cell re-selection. This is indicated by the parameter $NETWORK_CONTROL_ORDER$. The meaning of the different parameter values is specified as follows:

NC0	Normal MS control The MS shall perform autonomous cell re-selection.
NC1	MS control with measurement reports The MS shall send measurement reports to the network as defined in subclause 10.1.4.1. The MS shall perform autonomous cell re-selection.
NC2	Network control The MS shall send measurement reports to the network as defined in subclause 10.1.4.1. The MS shall only perform autonomous cell re-selection when the reselection is triggered by a downlink signalling failure as defined in subclause 6.5 or a random access failure as defined in 3GPP TS 04.18 and 3GPP TS 04.60.
RESET	The MS shall return to the broadcast parameters. Only sent on PCCCH or PACCH.

The parameter values NC1 and NC2 only apply in Ready state. In Standby state, the MS shall always use normal MS control independent of the ordered NC mode.

A set of measurement reporting parameters ($NETWORK_CONTROL_ORDER$, $NC_REPORTING_PERIOD(s)$ and optionally $REPORT_TYPE$, $MULTIBAND_REPORTING$, $SERVING_BAND_REPORTING$, $XXX_MULTIRAT_REPORTING$, $XXX_REPORTING_OFFSET$, $XXX_REPORTING_THRESHOLD$ (XXX indicates frequency band or radio access technologies), $REP_PRIORITY$, $REPORTING_RATE$, $INVALID_BSIC_REPORTING$, $SCALE_ORD$, FDD_REP_QUANT , Q_{search_P} and $3G_SEARCH_PRIO$) is broadcast on PBCCH. This set of parameters may also be sent individually to an MS on PCCCH or PACCH in:

- a PACKET MEASUREMENT ORDER message, in which case it overrides the NC parameters broadcast in the serving cell. These individual parameters should be considered valid only in the serving cell.
- a PACKET CELL CHANGE ORDER message, in which case it overrides the NC parameters broadcast in the target cell. These individual parameters should be considered valid only in the target cell.

The individual parameters are valid until the RESET command is sent to the MS or there is a downlink signalling failure or the MS goes to the Standby state or the MS enters dedicated mode. Before the MS has acquired NC parameters when entering a new cell, it shall assume mode NC0 unless individual parameters were given by PACKET CELL CHANGE ORDER message in the previous cell.

A parameter NC_FREQUENCY_LIST may also be sent individually to an MS on PCCCH or PACCH. This list adds/deletes frequencies to the BA(GPRS) both for cell re-selection and for measurement reports. For added frequencies, the corresponding cell re-selection parameters may be included. The list is valid until an empty list is sent to the MS, there is a downlink signalling failure or the MS selects a new cell or the BA(GPRS) that is modified by the NC_FREQUENCY_LIST changes or the MS enters dedicated mode. A list given by Packet Cell Change Order applies in the new cell. The lists may also include cells with other radio access technologies.

All signalling for support of network controlled cell re-selection and measurement reports are defined in 3GPP TS 04.60.

10.1.4.1 Measurement reporting

When ordered to send measurement reports, the MS shall continuously monitor all carriers in BA(GPRS) or as indicated by the parameter NC_FREQUENCY_LIST and the BCCH carrier of the serving cell. The measurement requirements are defined in subclause 10.1.1 for the actual packet mode.

For each carrier, the measured received signal level (RXLEV) shall be the average of the received signal level measurement samples in dBm taken on that carrier within the reporting period. The reporting period is defined as follows:

- in packet idle mode, the reporting period is NC_REPORTING_PERIOD_I rounded off to the nearest smaller integer multiple of DRX period if NC_REPORTING_PERIOD_I is greater than DRX period, else, the reporting period is DRX period;
- in packet transfer mode, the reporting period is indicated in NC_REPORTING_PERIOD_T.

In averaging, measurements made during previous reporting periods shall always be discarded. The start of the first reporting period may be random.

After each reporting period, the MS shall send a measurement report to BSS (see 3GPP TS 04.60). The MS shall then discard any previous measurement report, which it has not been able to send. Provided that the MS has received BSIC for all GSM neighbour cells, the parameter REPORT_TYPE indicates if the MS shall use Packet Measurement Report (normal reporting) or Packet Enhanced Measurement Report (enhanced reporting) (see 3GPP TS 04.60). The measurement report shall contain:

- RXLEV for the serving cell;
- in packet idle mode, the average interference level γ_{ch} (see subclause 10.2.3.2.2) for the serving cell measured on the monitored PCCCH if a valid value is available. The mapping of γ_{ch} to the reported I_LEVEL value is defined in subclause 10.3;
- received signal level for the non-serving cells:
 - For normal measurement reporting, carriers shall be reported if they are among the 6 strongest carriers and BSIC is successfully decoded and allowed (see subclause 10.1.1), i.e. either equal to the BSIC of the list or with allowed NCC part of BSIC. In the latter case, which applies for BA(BCCH) where no BSIC is given, the decoded BSIC shall be included in the report. In the case of a multiband MS, the MS shall report the number of strongest BCCH carriers in each band as indicated by the parameter MULTIBAND_REPORTING (see subclause 8.4.3), broadcast on PBCCH, or if PBCCH does not exist, on BCCH. For multi-RAT MS, the MS shall report the number of best valid cells in each other radio access technology/mode as indicated by the parameters XXX_MULTIRAT_REPORTING, see subclause 8.4.7. In this case, the received signal level is replaced by the relevant measurement quantity (see subclause 8.1.5). Valid cells are defined in subclause 8.4.7;

- For Enhanced Measurement Reporting, cells shall be reported if they are among the at least 6 strongest carriers, and BSIC is successfully decoded and valid (see subclause 10.1.1) or, if indicated by the parameter INVALID_BSIC_REPORTING, with known and allowed NCC part. The neighbour cells shall be reported according to the priority defined in subclause 8.4.8.1. For other radio access technology/mode, RXLEV is replaced by the relevant measurement quantity (see subclause 8.1.5);
- BSIC_SEEN (only for Enhanced Measurement Reporting).
Indicates if a GSM cell with invalid BSIC and allowed NCC part of the BSIC is one of the at least six strongest cells.

In the case of Packet Transfer mode with the NC_REPORTING_PERIOD_T = 0.48 s the MS shall report a new strongest GSM cell in the measurement report at the latest 5 s after a new strongest cell (which is part of the BA(GPRS)) has been activated under the following network conditions: Initial serving cell at RXLEV= -70 dBm, with 6 neighbours at RXLEV= -75 dBm. Then the new BCCH carrier is switched on at RXLEV= -60 dBm.

Note: Because of test equipment limitations it is acceptable to activate the new carrier to replace one of the 6 neighbours.

A UTRAN capable MS shall report a new best UTRAN cell, which is part of the neighbour cell list, at the latest 5 seconds after it has been activated under the condition that there is only one UTRAN frequency in the neighbour cell list and that no new GSM cells are activated at the same time and under good radio conditions. For test purposes the following radio conditions can be used:

Serving GSM cell at RXLEV= -70 dBm, with 6 GSM neighbours at RXLEV= -75 dBm. Then either an UTRAN FDD neighbour cell or an UTRAN TDD neighbour cell is switched on. The radio conditions for the UTRAN FDD cells are as follows (see TS 25.101 for definitions):

Parameter	Unit	UTRAN FDD Cell
<i>CPICH_Ec/I_{or}</i>	dB	-10
<i>PCCPCH_Ec/I_{or}</i>	dB	-12
<i>SCH_Ec/I_{or}</i>	dB	-12
<i>PICH_Ec/I_{or}</i>	dB	-15
<i>DPCH_Ec/I_{or}</i>	dB	-∞
<i>OCNS</i>		-0.94
\hat{I}_{or}/I_{oc}	dB	10
<i>I_{oc}</i>	dBm/3.84 MHz	-70
<i>CPICH_Ec/I_o</i>	dB	-10.4
<i>CPICH_RSCP</i>	dBm	-70
FDD_MULTIRAT_REPORTING	integer	1
Qsearch_P	integer	7 (search always)
3G_SEARCH_PRIO	integer	1
Propagation Condition	AWGN	

The radio conditions for the UTRAN TDD cell (3.84 Mcps) are as follows (see 3GPP TS 25.123 for definitions and for the values of the remaining configuration parameters):

Parameter	Unit	UTRA TDD Cell (3.84 Mcps)	
<i>Timeslot Number</i>		0	8
<i>P-CCPCH_Ec/Ior</i>	dB	-3	
<i>SCH_Ec/Ior</i>	dB	-9	-9
<i>SCH_t_offset</i>	integer	0	0
<i>PICH_Ec/Ior</i>	dB		-3
<i>OCNS_Ec/Ior</i>	dB	-3.12	-3.12
<i>PCCPCH RSCP</i>	dBm	-70	-70
TDD_MULTIRAT_ REPORTING	integer	1	
Qsearch_P	integer	7 (search always)	
3G_SEARCH_PRIO	integer	1	
Propagation Condition	AWGN		

NOTE: On timeslot 8 the P-CCPCH is not transmitted; on that timeslot, the PCCPCH RSCP defines the power level of the beacon channel.

The allowed reporting time is increased by 5 seconds for each additional UTRAN frequency in the neighbour cell list and by the time required for BSIC decoding of new activated GSM cells. However, multiple UTRAN cells on the same frequency in the neighbour cell list does not increase the allowed reporting time.

In packet transfer mode, for some allowed multislot allocations (see 3GPP TS 05.02), identification of a TDD cell may not be guaranteed. In such cases, the MS may not be able to fulfil the requirement above. If after 5 seconds the MS has not been able to identify a TDD cell, the MS is allowed to stop searching for it in the current GSM cell.

10.1.4.2 Cell re-selection command

A cell re-selection command may be sent from the network to an MS. When the MS receives the command, it shall re-select the cell according to the included cell description and change the network control mode according to the command (see 3GPP TS 04.60). The command may include re-selection of another radio access technology/mode.

If an MS receives a cell re-selection command towards a GSM cell to which it is not synchronised, then the MS shall search for synchronisation information up to 300 ms. In case of failure, the MS shall return to the old cell and indicate a packet cell change failure (see 3GPP TS 04.60).

If a UTRAN capable MS receives a cell re-selection command towards a not known UTRAN cell (see 3GPP TS 25.133 and 3GPP TS 25.123), then the MS shall search for synchronisation information up to 800 ms. In case of failure, the MS shall return to the old cell and indicate a packet cell change failure (see 3GPP TS 04.60).

10.1.4.3 Exceptional cases

An MS in network control mode NC1 or NC2 may enter an exceptional case if a circuit switched connection is established, which takes precedence over GPRS cell re-selection. This includes an MS operating in DTM.

In such a case the MS is not required to send measurement reports according to subclause 10.1.4.1, and shall not obey any cell re-selection command.

Whenever the exceptional case ends, the MS shall resume the GPRS mode tasks as specified in sub-clause 10.

10.1.5 Extended Measurement reporting

The network may request measurement reports from the MS for other purposes than cell re-selection. This is indicated by the parameter EXT_MEASUREMENT_ORDER. The meaning of the different parameter values is specified as follows:

- EM0 The MS shall not perform extended measurements.
- EM1 The MS shall send extended measurement reports to the network.
- RESET The MS shall return to the broadcast parameters. Only sent on PCCCH, CPCCCH or PACCH.

All signalling for support of extended measurement reports are defined in 3GPP TS 04.60.

A set of measurement reporting parameters (EXT_MEASUREMENT_ORDER, EXT_FREQUENCY_LIST, EXT_REPORTING_PERIOD, EXT_REPORTING_TYPE, INT_FREQUENCY and NCC_PERMITTED) is broadcast on PBCCH or CPBCCH. The parameters may also be sent individually to an MS on PCCCH, CPCCCH or PACCH, in which case it overrides the broadcast parameters. The individual parameters are valid until the RESET command is sent to the MS, there is a downlink signalling failure or the MS selects a new cell.

When ordered to send extended measurement reports, the MS shall monitor all carriers as indicated by the parameter EXT_FREQUENCY_LIST. The parameter EXT_REPORTING_TYPE indicates one of three different types of reporting:

- Type 1: Carriers that shall be reported if they are among the 6 strongest carriers regardless of whether BSIC was decoded or not. The measurement report shall contain received signal level and, if successfully decoded, BSIC.
- Type 2: Carriers that shall be reported if they are among the 6 strongest carriers and BSIC is successfully decoded and with allowed NCC part as indicated by NCC_PERMITTED. The measurement shall contain received signal level and BSIC.
- Type 3: Carriers that shall be reported without BSIC decoding. The measurement report shall contain received signal level. In addition interference may be reported for one carrier.

At least one received signal level measurement sample on each carrier shall be taken for each paging block monitored by the MS according to its current DRX mode and its paging group. If PBCCH does not exist, the MS is only required to take seven measurement samples per BS_PA_MFRMS multiframe. These measurements shall not reduce the rate of measurements for cell re-selection as defined in subclause 10.1.1.1, 6.6.1 or 12.4.1.1 respectively. However, in total the MS is not required to make more than 200 samples per second. For each carrier, the measured received signal level (RXLEV) shall be the average of the received signal level measurement samples in dBm taken on that carrier within the reporting period as indicated by the parameter EXT_REPORTING_PERIOD. In averaging, measurements made during previous reporting periods shall always be discarded. The start of the first reporting period may be random.

For report type 3, the parameter INT_FREQUENCY, if it exists and if PBCCH exists, indicates one carrier on which interference measurements shall be performed. For COMPACT, this carrier should be in the serving cell, otherwise the accuracy of interference measurement reporting may be compromised. The measurements shall be made in the search frames and PTCCH frames of the 52-multiframe as described in subclause 10.2.3.2.1. During at least two contiguous such frames (one of each type) per paging period, the MS shall make measurements on as many channels (timeslots) as possible on the indicated carrier, considering its DRX mode and multislot class. Averaging shall be done within the reporting period. For COMPACT, interference measurements shall be performed during PDTCH/PACCH blocks as described in subclause 10.2.3.2.1.

The measurement samples shall be taken, as uniformly distributed as possible for each carrier, during the first 480 ms of the reporting period or until 5 samples have been taken on each carrier, whichever is longer. If the MS is in packet transfer mode or in an exceptional case (see subclause 10.1.4.3.) when the measurements shall start, the MS shall wait until it returns to packet idle mode. If the MS enters packet transfer mode or an exceptional case during the measurement period, the measurements shall be discarded and the measurements restarted when the MS returns to packet idle mode. If the MS is not able to collect the required measurements during one reporting period due to its DRX period, it may continue the measurements during the next reporting period. In this case no report shall be sent in the first reporting period.

For type 1 and 2 reporting, the MS shall attempt to decode the BSIC for the 6 strongest carriers in each reporting period, as close to the measurements as possible. Priority shall however be given to decoding BSIC for cell re-selection to fulfil the requirements in subclauses 10.1.1.2 and 12.4.1.2.

After collecting the measurements for one reporting period, the MS shall send a measurement report to BSS (see 3GPP TS 04.60). The measurement report shall be sent independently of the packet mode but not in the exceptional cases defined in subclause 10.1.4.3.

10.2 RF Power Control

Sub-clauses 10.2.1 and 10.2.2 do not apply for the PDCH/H in Exclusive MAC mode while in DTM. In this case:

- The MS shall apply the output power ordered by the network on the SACCH to all channels (both the TCH/H and the PDCH/H).

- The network shall use the same output power on the dedicated connection and on all the blocks on the PDCH/H addressed to the MS. Blocks not addressed to the MS may be transmitted at a lower power level. As an exception, the bursts transmitted on the BCCH carrier shall be transmitted at the BCCH level.

NOTE: Power control is not applicable to point-to-multipoint services.

10.2.1 MS output power

The RF output power, P_{CH} , to be employed by the MS on each individual uplink PDCH shall be:

$$P_{CH} = \min(\Gamma_0 - \Gamma_{CH} - \alpha * (C + 48), P_{MAX}), \quad (1)$$

where

Γ_{CH}	is an MS and channel specific power control parameter, sent to the MS in an RLC control message (see 3GPP TS 04.60). For those uplink PDCHs, for which Γ_{CH} has not been defined, value 0 shall be used.
Γ_0	= 39 dBm for GSM 400, GSM900, GSM850 = 36 dBm for DCS1 800 and PCS 1900
α	is a system parameter, broadcast on PBCCH or optionally sent to MS in an RLC control message (see 3GPP TS 04.18 and 3GPP TS 04.60).
C	is the normalised received signal level at the MS as defined in 10.2.3.1.
P _{MAX}	is the maximum allowed output power in the cell = GPRS_MS_TXPWR_MAX_CCH if present, MS_TXPWR_MAX_CCH otherwise

All power values are expressed in dBm.

When the MS receives new Γ_{CH} or α values, the MS shall use the new value to update P_{CH} according to equation (1) 2 radio blocks after the end of the frame containing the last timeslot of the message block containing the new value, which ensures 2 blocks time for processing even in case of timeslot reconfiguration.

The MS may round the calculated output power to the nearest nominal output power value (see 3GPP TS 05.05) although a higher resolution is preferred. The output power actually transmitted by the MS shall fulfil the absolute accuracy as specified in 05.05. In addition, the transmitted power shall be a monotonic function of the calculated output power and any change of 2 dB in the calculated value shall correspond to a change of 2 ± 1.5 dB in the transmitted value.

The MS shall use the same output power on all four bursts within one radio block.

When accessing a cell on the PRACH or RACH (random access) and before receiving the first power control parameters during packet transfer on PDCH, the MS shall use the output power defined by P_{MAX}.

MS_TXPWR_MAX_CCH is broadcast on the BCCH of the cell. A class 3 DCS1 800 MS shall add to it the value POWER_OFFSET broadcast on the BCCH.

GPRS_MS_TXPWR_MAX_CCH is broadcast on PBCCH or CPBCCH of the serving cell and in case of DTM, sent on SACCH and optionally on main DCCH.

If the MS accesses a cell on the PRACH before receiving GPRS_MS_TXPWR_MAX_CCH on PBCCH, the MS shall determine P_{MAX} using MS_TXPWR_MAX_CCH as default.

If a calculated output power is not supported by the MS, the MS shall use the supported output power which is closest to the calculated output power.

10.2.2 BTS output power

Downlink power control can only be used when the serving BCCH or CPBCCH and the used PDCH frequencies are in the same frequency band.

On the PDCHs that contain PBCCH or PCCCH, the BTS shall use constant output power, which may be lower than the output power used on BCCH. The power reduction (P_b) used on PCCCH, relative to the output power used on BCCH, is broadcast on PBCCH. For COMPACT, on the blocks that contain CPBCCH, CPCCCH, CFCCH, or CSCH, the BTS shall use constant output power.

On PTCCH/D, the BTS shall use the same output power as for PBCCH, or BCCH if PBCCH does not exist. As an exception to this, the output power for some of the PTCCH/D blocks may be lower in some cases (e.g. with adaptive antennas), but with no requirements for the MS to decode them. The network is however responsible to provide each MS with required TA information.

On other PDCH radio blocks, downlink power control may be used. The BTS shall use the same output power on all four bursts within one radio block except for bursts transmitted on the BCCH carrier. Thus, a procedure may be implemented in the network to control the output power of the downlink transmission based on the Channel Quality Reports.

On PDCHs that do not contain PBCCH or PCCCH and do not use downlink power control (as indicated in the assignment message), the BTS shall use a constant output power with the exception that it is not required to transmit on every block. If the output power used on the transmitted blocks is not equal to (BCCH level – P_b) then the MS is not required to fulfil 3GPP TS 05.05 requirements for the first 25 blocks addressed to this MS.

Two methods of downlink power control exist. Power control mode A can be used for any allocation method. Power control mode B can only be used for fixed allocation. The method used is determined by the `BTS_PWR_CTRL_MODE` as sent in the assignment command.

In both power control mode, parameter P_0 is used: P_0 is defined as a power reduction relative to BCCH or CPBCCH and is included in the assignment message. The value of P_0 is not allowed to change during Packet Transfer Mode except in the case a reassignment or a new assignment is established not including any of the previously allocated PDCH(s). An MS shall only have one P_0 value and one power control mode at a time.

On each PDTCH/D block, the PR field of the MAC header, if present and if downlink power control is used, shall indicate the output power level used to send this block (see 3GPP TS 04.60). There shall be two PR management cases, PR mode A and PR mode B, as indicated by the `PR_MODE` parameter in the assignment (see 3GPP TS 04.60) :

- in PR mode A, the PR field of a block is calculated based on the BTS output power level in the direction of the addressed (RLC information) MS;
- in PR mode B, for each block sent on a given PDCH, the BTS shall use the same output power level for all the MS with TBF on this PDCH.

The network shall not be allowed to change between PR modes during a TBF. The network shall only allocate to an MS one `PR_MODE` at a time.

NOTE: Correct MS behaviour can not be assumed if PR mode B is used with adaptive antennas.

The MS is required to meet the 05.05 specification under the following conditions:

For synchronization purpose, the network shall ensure that each MS with an active TBF in uplink or downlink receives at least one block transmitted with a coding scheme and a modulation that can be decoded by that MS every 360 millisecond interval (78 TDMA frames) If downlink power control is used, this block shall be transmitted with an output power which is consistent with the downlink power control mode used and

- in PR mode A, this block shall be addressed (RLC information) to this MS and shall contain a usable PR field (i.e. not set to Not usable as specified in 3GPP TS 04.60);
- in PR mode B, this block shall contain a usable PR field (i.e. not set to Not usable as specified in 3GPP TS 04.60) and does not necessarily have to be addressed to any particular MS.

If power control mode A is used, the BTS shall limit its output power on blocks addressed to a particular MS (USF or RLC blocks) to levels between (BCCH level – P_0 dB) and (BCCH level – P_0 dB – 10dB). For other blocks the output power shall not exceed (BCCH level – P_0 dB). For COMPACT, the BCCH level shall be replaced by the CPBCCH level in these formulas. The output power must be sufficient for the MS for which the RLC block is intended as well as the MS(s) for which the USF is intended (see 3GPP TS 04.60).

In PR mode A, the PR value shall be calculated relative to the P_0 value of the MS to which the RLC block is addressed.

In PR mode B, the network shall use the same P0 value for all the MS with a TBF established on the same PDCH. Consequently, the PR value shall be calculated relative to this P0 value.

If power control mode B is used, the full BTS power output range may be used. Further, the BTS shall adhere to the following:

- (BCCH level – P0dB) is the initial downlink BTS output power;
- the power shall be the same on all blocks addressed to a particular multislot MS (RLC information) within a TDMA frame;
- for the sequence of downlink blocks addressed to a particular MS, the network shall change the BTS output power of such blocks no faster than one nominal power control step every 60 ms (13 TDMA frames). Further, when the network changes the BTS output power from level X to level Y for the sequence of downlink blocks addressed to a particular MS, the network shall transmit at least one block addressed to the MS at each BTS power output level between level X and level Y on at least one of the PDCHs allocated to this MS;
- the output power must be sufficient for the MS for which the RLC block is intended;
- the output power on the timeslot immediately preceding each burst of a block addressed to one MS, and belonging to the same multislot allocation, shall not exceed the output power of that block by more than 10 dB.

As an exception to the rules above for both modes, the bursts transmitted on the BCCH carrier shall be transmitted at the BCCH level.

In DTM multislot configurations, when power control mode A is used, if the BTS output power for the CS timeslot is not within the range from the maximum downlink power allowed for the MS on the PS timeslot(s) to a power level 10 dB lower, the MS is not required to fulfil the requirements in 3GPP TS 05.05 on the CS timeslot and/or the PS timeslot(s).

10.2.3 Measurements at MS side

A procedure shall be implemented in the MS to monitor periodically the downlink Rx signal level and quality from its serving cell.

10.2.3.1 Deriving the C value

10.2.3.1.1 Packet idle mode

In packet idle mode, the MS shall periodically measure the received signal level of the PCCCH or, if PCCCH is not existing, the CCCH or, for COMPACT, the CPCCCH or CPBCCH, CFCCH, and CSCH. The MS shall measure the received signal level of each paging block monitored by the MS according to its current DRX mode and its paging group.

The normalised C value for each radio block is calculated:

$$C_{\text{block},n} = SS_{\text{block},n} + P_b \quad (2)$$

where

$SS_{\text{block},n}$ is the mean of the received signal level of the four normal bursts that compose the block.

P_b is the BTS output power reduction (relative to the output power used on BCCH) used on the channel on which the measurements are performed. For PCCCH, P_b is broadcast on PBCCH. If frequency hopping is being used on the associated physical channel, P_b shall be reduced by 25% for each burst in the block which is received on the BCCH frequency. For BCCH and for COMPACT, $P_b = 0$ (not broadcast).

Finally, the $C_{\text{block},n}$ values are filtered with a running average filter:

$$C_n = (1-a) * C_{n-1} + a * C_{\text{block},n},$$

where a is the forgetting factor:

$$a = 1/\text{MIN}(n, \text{MAX}(5, T_{\text{AVG}_W} * N_{\text{DRX}})).$$

N_{DRX} = the average number of monitored blocks per multiframe according to its current DRX mode and its paging group (see 3GPP TS 05.02).

T_{AVG_W} is broadcast on PBCCH or, if PBCCH does not exist, on BCCH, or on CPBCCH. BS_PA_MFRMS is broadcast on BCCH. SPLIT_PG_CYCLE is defined at GPRS attach.

n is the iteration index. The filter shall be restarted with $n=1$ for the first sample every time a new cell is selected. Otherwise, when entering packet idle mode, the filter shall continue from the n and C_n values obtained during packet transfer mode. The filter shall also continue from its previous state if N_{DRX} is changed.

The current C_n value shall be used in formula (1) to calculate the output power when the MS transfers its first radio block.

10.2.3.1.2 Packet transfer mode

In packet transfer mode, the MS shall use the same received signal level measurements as made for cell reselection on the BCCH carrier of the serving cell (see 10.1.1.2) or, for COMPACT, on the CPBCCH carrier of the serving cell (see 12.4.1.2). The measurements shall be filtered with a running average filter:

$$C_n = (1-b) * C_{n-1} + b * SS_n,$$

where

SS_n is the received signal level of the measurement samples.

b is the forgetting factor:

$$b = 1/(6 * T_{\text{AVG}_T}).$$

n is the iteration index. When entering packet transfer mode, the filter shall continue from the n and C_n values obtained during packet idle mode.

If indicated by the parameter PC_MEAS_CHAN , the MS shall instead measure the received signal level of each radio block on one of the PDCH monitored by the MS for PACCH. If downlink power control is used, PC_MEAS_CHAN shall indicate measurements on the BCCH or CPBCCH, or the MS is not required to fulfil 05.05 requirements. The MS may discard new PC_MEAS_CHAN values received during packet transfer mode. For each downlink radio block $C_{\text{block},n}$ shall be derived according to formula (2) (if PBCCH does not exist, and for COMPACT, $P_b = 0$). Finally, the $C_{\text{block},n}$ values are filtered with a running average filter:

$$C_n = (1-c) * C_{n-1} + c * C_{\text{block},n},$$

where c is the forgetting factor:

$$c = 1/(12 * T_{\text{AVG}_T}).$$

n is the iteration index. When entering packet transfer mode, the filter shall continue from the n and C_n values obtained during packet idle mode.

NOTE 1: This method is suitable in the case where BCCH or CPBCCH is in another frequency band than the used PDCHs.

The current C_n value shall be used to update formula (1) each time a new C_n value is obtained or whenever the MS applies new Γ_{CH} or α values.

For each correctly received block on one of the PDCHs monitored by the MS, the MS shall calculate the variance of the received signal level as:

$$BL_VAR_n = 1/(j-1) * \text{SUM}(SS_k - SS_{block,n})^2, k = 1, \dots, 4$$

where SS_k is the received signal level of burst k within the block.

$SS_{block,n}$ is the mean of the received signal level of the j normal bursts that compose the radio block.

j is the number of bursts in the radio block = 4.

If frequency hopping is used and 1 burst of the block is received on the BCCH carrier, that burst shall be discarded from the calculation ($j = 3$). If 2 bursts are received on the BCCH carrier, the whole block shall be discarded. If 3 bursts are received on the BCCH carrier, the other burst shall be discarded ($j = 3$).

If more than one PDCH are monitored the MS shall for each block period try to find one correctly received block for the BL_VAR calculation. The block may be taken from any of the monitored PDCHs.

The reported value, SIGN_VAR, shall be the average of BL_VAR within the reporting period. The first reporting period starts with and includes the first assignment message for an uplink or downlink transfer. The reporting period ends, and the subsequent reporting period starts, no earlier than two blocks before the transmission of a quality report and no later than one block before the transmission of a quality report. In averaging, measurements made during previous reporting periods shall always be discarded.

SIGN_VAR shall be included in the channel quality report (see subclause 10.2.3.2.3). If the channel quality report is included in a PACKET RESOURCE REQUEST message, which is retransmitted due to lack of response (see 3GPP TS 04.60), the same SIGN_VAR value shall be repeated and no new reporting period shall be started. This will ensure that a valid SIGN_VAR value exists.

An MS, performing an uplink transfer using half duplex mode (see 04.60 for definition of half duplex mode), is not required to make received signal level measurements and shall thus update P_{CH} during its uplink allocation, only when it receives new Γ_{CH} values. The MS shall in this case use the last C_n value measured before the uplink transfer.

T_{AVG_T} and PC_MEAS_CHAN are broadcast on PBCCH or, if PBCCH does not exist, on BCCH or on CPBCCH.

10.2.3.2 Derivation of Channel Quality Report

The channel quality is measured as the interference signal level during idle frames of the multiframe, when the serving cell is not transmitting. No measurements shall be taken on the BCCH carrier of the serving cell since the BTS transmits with constant output power on this carrier. For COMPACT, the channel quality is measured as the interference signal level during a PDTCH or PACCH block (see Annex C). No measurements shall be taken on the CPBCCH, CPCCCH, PTCCH, CFCCH, or CSCH since the BTS of the neighbouring co-channel cells either does not transmit or transmits with constant output power.

10.2.3.2.1 Packet transfer mode

In packet transfer mode, the MS shall measure the interference signal level on the same carrier as the assigned PDCHs. The MS shall make these measurements during the search frames and PTCCH frames, which are not required for BSIC decoding or the timing advance procedure. For COMPACT, the MS shall estimate the interference level during PDTCH/PACCH bursts (see Annex C).

Additionally, a multi-RAT MS is allowed to ignore interference signal level measurements in search frames according subclause 10.1.1.3.

The MS shall perform interference signal measurements on as many of the channels (timeslots) as possible and as a minimum:

For multislot class type 1 MS (see 3GPP TS 05.02), on the PDCH timeslot numbers TS_{min} to TS_{max} , where

TS_{min} = the lowest numbered timeslot allocated for uplink or downlink transfer including downlink PACCH associated with an uplink transfer.

$$TS_{max} = \text{MIN}(TS_{min} + R_x - 1, 7).$$

R_x = the maximum number of receive timeslots that the MS can use per TDMA frame according to its multislot class (see 3GPP TS 05.02).

For multislot class type 2 MS (see 3GPP TS 05.02), on the maximum number of receive timeslots (R_x) that the MS can use per TDMA frame according to its multislot class (see 3GPP TS 05.02), in the following priority order, except that no measurements are required on any timeslot number below those with priority 1:

- 1) the PDCH timeslot numbers assigned for downlink transfer including the downlink PACCH associated with an uplink transfer;
- 2) the PDCH timeslot numbers assigned for uplink transfer;
- 3) other timeslots that would be possible to add for downlink transfer to the current allocation according to the MS's multislot class. If more than one combination of timeslots is possible according to this rule, it is implementation dependent which combination to choose.

Interference measurement timeslots have lower priority than real receiver or transmit timeslot and are not compulsory in case of conflict.

For each channel, every measurement $SS_{CH,n}$ shall consist of the minimum of the two signal level samples from one search frame and one PTCCH frame. These two measurements should be spaced as closely as possible, but there is no requirement that they shall be contiguous. Thus the SACCH frames are avoided (except for a physical channel with two TCH/Hs) and only the interference is measured. For COMPACT, for each channel, at least two interference measurement sample, $SS_{CH,n}$, shall be taken every multiframe.

The measured interference shall be averaged in a running average filter:

$$\gamma_{CH,n} = (1-d) * \gamma_{CH,n-1} + d * SS_{CH,n}, \gamma_{CH,0} = 0$$

where d is the forgetting factor:

$$d = 1/\text{MIN}(n, N_{AVG_I}).$$

n is the iteration index.

The filter shall be restarted with $n=1$ for the first sample every time a new cell is selected. If the measurements on a channel is interrupted due to a change of packet mode (transfer or idle), the last obtained n and $\gamma_{CH,n}$ values shall be saved. When entering packet transfer mode, the filter shall continue from the values obtained during packet idle mode for those channels that are measured in both modes. If frequency hopping is used, channels that only differ in MAIO shall be considered the same. For the other channels, if the measurements are resumed for the same channel within $N_{AVG_I}/2$ multiframe, the filter shall continue from the saved values. Otherwise the filter shall be restarted. Channel reassignment during packet transfer mode shall be considered as start of a new packet transfer mode preceded by a zero length packet idle mode.

For each channel, the MS shall perform at least N_{AVG_I} (rounded to the nearest integer) measurements of $SS_{CH,n}$ before valid γ_{CH} values can be determined

During GPRS downlink TBF transfer, the MS shall measure the received signal quality as defined in subclause 8.2. The reported value, $RXQUAL$, shall be the average within the reporting period. Only successfully decoded blocks intended for that MS shall be included in the average. Alternatively, if CS4 is used, the MS is allowed to report $RXQUAL = 7$. The first reporting period starts with and includes the first assignment message for the downlink transfer. The reporting period ends, and the subsequent reporting starts, no earlier than two blocks before the transmission of a quality report and no later than one block before the transmission of a quality report. In averaging, measurements made during previous reporting periods shall always be discarded.

During EGPRS downlink TBF transfer, the MS shall measure the received signal quality as defined in subclause 8.2. The quality parameters shall be, for the radio blocks intended for this MS only (of which the right TFI could be decoded: see 3GPP TS 04.60), individually averaged per channel (timeslot) and per modulation type as follows:

$$R_n = (1-e) \cdot R_{n-1} + e \cdot x_n, R_{-1} = 0$$

$$\text{MEAN_BEP_TN}_n = (1-e) \cdot \frac{x_n}{R_n} \cdot \text{MEAN_BEP_TN}_{n-1} + e \cdot \frac{x_n}{R_n} \cdot \text{MEAN_BEP}_{\text{block}n}$$

$$CV_BEP_TN_n = (1 - e \cdot \frac{x_n}{R_n}) \cdot CV_BEP_TN_{n-1} + e \cdot \frac{x_n}{R_n} \cdot CV_BEP_{blockn}$$

Where: n is the iteration index, incremented per each downlink radio block.

R_n denotes the reliability of the filtered quality parameters.

e is the forgetting factor defined below.

x_n denotes the existence of quality parameters for the n^{th} block, i.e. if the radio block is intended for this MS. x_n values 1 and 0 denote the existence and absence of quality parameters, respectively.

In case BEP_PERIOD2 is received and with a field value different than 15, e shall be defined as e_2 according to BEP_PERIOD2 as shown in the table below. This allows for individual filtering per MS.

In case BEP_PERIOD2 is received and with the field value 15 (norm), e shall be defined as e_1 according to BEP_PERIOD as shown in the table below. This allows for normal filtering (non-individual). This BEP_PERIOD2 shall be used by the considered MS in the serving cell, until a new BEP_PERIOD2 is received by this MS in the same cell, or the MS leaves the cell or the MS enters packet idle mode.

Field value	15	14	13	12	11	10	9	8	7	6	5	4	3	2	1	0
BEP_PERIOD	Reserved					25	20	15	12	10	7	5	4	3	2	1
e_1	-					0.08	0.1	0.15	0.2	0.25	0.3	0.4	0.5	0.65	0.8	1
BEP_PERIOD2	Norm	90	70	55	40	25	20	15	12	10	7	5	4	3	2	1
e_2	e_1	0.03	0.04	0.05	0.065	0.08	0.1	0.15	0.2	0.25	0.3	0.4	0.5	0.65	0.8	1

BEP_PERIOD2 is sent to individual MS on PACCH D/L. See 3GPP TS 04.60.

BEP_PERIOD is broadcast on PBCCH or, if PBCCH does not exist, on BCCH.

An MS shall report the overall MEAN_BEP, and CV_BEP per modulation type averaged over all allocated channels (timeslots) as follows:

$$MEAN_BEP_n = \frac{\sum_j R_n^{(j)} \cdot MEAN_BEP_TN_n^{(j)}}{\sum_j R_n^{(j)}}$$

$$CV_BEP_n = \frac{\sum_j R_n^{(j)} \cdot CV_BEP_TN_n^{(j)}}{\sum_j R_n^{(j)}}$$

where n = the iteration index at reporting time

j = the channel number.

When entering packet transfer mode and/or when selecting a new cell, the filters shall reset the values of n to 0.

When a new timeslot is allocated for a downlink TBF, the filters shall reset the values of $MEAN_BEP_{n-1}$, CV_BEP_{n-1} and R_{n-1} to 0 for this timeslot.

The MS shall transfer the $8\gamma_{CH}$ values and the RXQUAL, C and SIGN_VAR values (see subclause 10.2.3.1.2) to the network in the Channel Quality Report sent on PACCH. An MS using EGPRS shall instead of RXQUAL and SIGN_VAR send MEAN_BEP and CV_BEP. The MS shall report MEAN_BEP and CV_BEP for the modulations, GMSK and/or 8-PSK (i.e. GMSK_MEAN_BEP, GMSK_CV_BEP; and/or 8PSK_MEAN_BEP, 8PSK_CV_BEP respectively), for which it has received blocks since it last sent a measurement report to the network. Additionally, the MS shall report per slot measurements ($MEAN_BEP_TN_x$) according to what the network has ordered (see 3GPP TS 04.60). The reporting period ends no earlier than two blocks for a GPRS TBF mode and three blocks for an EGPRS TBF mode before the transmission of a quality report and no later than one block before the transmission of a quality report.

N_{AVG_I} is broadcast on PBCCH or, if PBCCH does not exist, on BCCH or CPBCCH.

10.2.3.2.2 Packet idle mode

In packet idle mode, the MS shall measure the interference signal level on the channels indicated by the parameter INT_MEAS_CHANNEL_LIST and, for an MS performing measurements according to subclause 10.1.4.1, on the monitored PCCCH or CPCCCH and, if indicated in the EXT_FREQUENCY_LIST, on one additional carrier (see subclause 10.1.5). INT_MEAS_CHANNEL_LIST is optionally broadcast on PBCCH or CPBCCH. The MS shall perform interference measurements on as many of the indicated basic physical channels (see 3GPP TS 05.02) as possible. For each frequency or mobile allocation independently, the minimum requirement is:

- for multislot class type 1 MS (see 3GPP TS 05.02), on the PDCH timeslot numbers TS_{min} to TS_{max} , where $TS_{max} = \text{MIN}(TS_{min} + Rx - 1, 7)$, and TS_{min} is selected so that as many as possible of the indicated timeslots are measured. Rx is the maximum number of receive timeslots that the MS can use per TDMA frame according to its multislot class (see 3GPP TS 05.02);
- for multislot class type 2 MS (see 3GPP TS 05.02), on the maximum number of receive timeslots (Rx) that the MS can use per TDMA frame according to its multislot class (see 3GPP TS 05.02). It is implementation dependent which timeslots are measured.

If the MS monitors PCCCH/CPCCCH or PBCCH/CPBCCH in the block preceding or succeeding the measurement frame, the MS may select the measurement timeslots such that the monitored timeslot is within the range from the lowest to the highest measured timeslot number. If INT_MEAS_CHANNEL_LIST does not exist and the MS is not performing measurements according to subclause 10.1.4., the MS is not required to perform any interference measurements. If PBCCH or CPBCCH do not exist, the MS is not required to perform interference measurements.

These measurements shall be made in the search frames and the PTCCH frames. During each paging period, if such frames are available and not required for BSIC decoding or PCCCH monitoring, the MS shall make the required measurements on at least one of the following carriers: carriers in the INT_MEAS_CHANNEL_LIST, monitored PCCCH and the carrier indicated in the EXT_FREQUENCY_LIST. The measurements ($SS_{CH,n}$) for each channel shall be made on contiguous search and PTCCH frames (one of each type) and averaged in the same way as described in subclause 10.2.3.2.1. The measurements shall, as far as possible, be uniformly distributed over the measurement period.

For COMPACT, these measurements shall be made during PDTCH/PACCH blocks and averaged in the same way as described in subclause 10.2.3.2.1. During each paging period, the MS shall make one measurement ($SS_{CH,n}$) on each indicated channel (timeslot) on at least one of the following carriers: carriers in the INT_MEAS_CHANNEL_LIST, monitored CPCCCH and the carrier indicated in the EXT_FREQUENCY_LIST. The measurements for each channel shall be made, as far as possible, uniformly distributed over the measurement period.

The filter shall be restarted with $n=1$ for the first sample every time a new cell is selected. If the measurements on a channel is interrupted due to a change of packet mode (transfer or idle), the last obtained n and $\gamma_{CH,n}$ values shall be saved. When entering packet idle mode, the filter shall continue from the values obtained during packet transfer mode for those channels that are measured in both modes for channel quality report. If frequency hopping is used, channels that only differ in MAIO shall be considered the same. For the other channels, if the measurements are resumed for the same channel within $KC \cdot N_{AVG,I}/4$ multiframes or $KC \cdot N_{AVG,I}/2$ paging periods, whichever is greater, the filter shall continue from the saved values. Otherwise the filter shall be restarted. KC is the number of carriers in the INT_MEAS_CHANNEL_LIST.

For each channel, the MS shall perform at least $N_{AVG,I}$ (rounded to the nearest integer) measurements of $SS_{CH,n}$ before valid γ_{CH} values can be determined.

$N_{AVG,I}$ is broadcast on PBCCH or, if PBCCH does not exist, on BCCH or CPBCCH.

10.2.3.2.3 Measurement reporting

The MS shall send a Channel Quality Report to the network in the PACKET DOWNLINK ACK/NACK and the PACKET RESOURCE REQUEST messages. The report contains the available γ_{CH} values for the carrier on which the message is sent as well as the RXQUAL, C and SIGN_VAR values (see subclause 10.2.3.1.2). The conditions for including the different values, which are not always mandatory, are specified in 3GPP TS 04.60. The mapping of γ_{ch} to the reported I_LEVEL value is defined in subclause 10.3.

10.2.4 Measurements at BSS side

A procedure shall be implemented in the BSS to monitor the uplink Rx signal level and quality on each uplink PDCH, active as well as inactive.

The BSS shall also measure the Rx signal level and the quality of a specific MS packet transfer.

10.3 Measurement requirements

The accuracy of the received signal level and interference measurements shall be as defined in subclause 8.1.2. For COMPACT, the accuracy of the interference estimate, which is based upon received signal level during a PDTCH/PACCH block (see Annex C), is ± 2 dB in addition to the accuracy of the received signal level defined in subclause 8.1.2 without downlink power control activated on the serving cell. The measured signal strength values shall be mapped to the reported C values as defined for RXLEV in subclause 8.1.4. If included in a PACKET MEASUREMENT REPORT message, the measured interference level, γ_{CH} , shall be mapped to a reported I_LEVEL as defined for RXLEV in subclause 8.1.4. If included in a PACKET DOWNLINK ACK/NACK or a PACKET RESOURCE REQUEST message, the measured interference level, γ_{CH} , shall be mapped to a reported I_LEVEL value between 0 and 15, relative to reported C value as follows:

- I_LEVEL 0 = interference level is greater than C
- I_LEVEL 1 = interference level is less than or equal to C and greater than C - 2 dB
- I_LEVEL 2 = interference level is less than or equal to C - 2 dB and greater than C - 4 dB
- :
- :
- I_LEVEL 14 = interference level is less than or equal to C - 26 dB and greater than C - 28 dB
- I_LEVEL 15 = interference level is less than or equal to C - 28 dB

For COMPACT, a mobile station shall not be required to meet the specified interference estimate accuracy requirements if the TSCs for PDTCH/PACCH blocks on primary and secondary carriers that are indicated in EXT_FREQUENCY_LIST by parameter INT_FREQUENCY and in INT_MEAS_CHAN_LIST (see subclauses 10.1.5 and 10.2.3.2.2 of this specification), are not equal to the BCC, as defined in 3GPP TS 03.03 and as described in 3GPP TS 05.02. For COMPACT, the supporting of interference measurements is optional except for allocated channels.

10.4 Control parameters

The parameters employed to control the radio links for GPRS are shown in table 3.

Table 3: Radio sub-system link control parameters for GPRS
((s) and (n) denote serving cell and non-serving cell respectively)

Parameter name	Description	Range	Bits	Channel
BA(GPRS)	BCCH Allocation for GPRS re-selection Note: If PBCCH does not exist, BA(GPRS) = BA(BCCH)	-	-	PBCCH D/L
BSIC(s+n)	Base station Identification Code for carriers in BA(GPRS) and the serving BCCH carrier	0-63	6	PBCCH D/L (**)
MS_TXPWR_MAX_CCH	See table 1.	0-31	5	BCCH D/L
POWER_OFFSET(s)	See table 1.	0-3	2	BCCH D/L
RXLEV_ACCESS_MIN	See table 1.	0-63	6	BCCH D/L
GPRS_MS_TXPWR_MAX_CCH(s+n)	The maximum TX power level an MS may use when accessing the system	0-31	5	PBCCH D/L
GPRS_RXLEV_ACCESS_MIN(s+n)	Minimum received signal level at the MS required for access to the system.	0-63	6	PBCCH D/L
GPRS_RESELECT_OFFSET (n)	Applies an offset and hysteresis to the C32 re- selection criterion. -52, -48, ..., -12, -10, ..., 12, 16, ..., 48 dB	0-31	5	PBCCH D/L
PRIORITY_CLASS (s+n)	The HCS priority for the cells	0-7	3	PBCCH D/L
LSA_ID (s+n)	The LSA identities for the cells			PBCCH D/L
HCS_THR(s+n)	HCS signal level threshold -110, -108, ..., -50, infinity dBm	0-31	5	PBCCH D/L
GPRS_TEMPORARY_OFFSET(n)	Applies a negative offset to C32 for the duration of PENALTY_TIME. 0, 10, ..., 60 dB, infinity	0-7	3	PBCCH D/L
GPRS_PENALTY_TIME(n)	Gives the duration for which the temporary offset is applied. 10, 20, ..., 320 seconds	0-31	5	PBCCH D/L
GPRS_CELL_RESELECT_ HYSTERESIS	Additional hysteresis applied in Ready state for cells in the same RA. 0, 2, ..., 14 dB	0-7	3	PBCCH D/L
RA_RESELECT_HYSTERESIS	Additional hysteresis applied for cells in different RAs. 0, 2, ..., 14 dB	0-7	3	PBCCH D/L
CELL_RESELECT_HYSTERESIS	Additional hysteresis applied for cells in different RAs if PCCCH does not exist. See table 1.	0-7	3	BCCH D/L
C32_QUAL	Flag indicating an exception rule for GPRS_RESELECT_OFFSET	1/0	1	BBCCH D/L
C31_HYST	Flag indicating if hysteresis shall be applied to C31.	1/0	1	PBCCH D/L
MULTIBAND_REPORTING	The number of carriers from each frequency band that shall be included in the list of 6 strongest cells or in the measurement report.	0-3	2	PBCCH D/L BCCH D/L
α	Power control parameter 0, 0.1, ..., 1	0-10	4	PBCCH D/L (**)
Pb	Power reduction used by BTS on PBCCH blocks, relatively to the output power used on BCCH 0, -2, ..., -30 dB	0-15	4	PBCCH D/L
PC_MEAS_CHAN	Flag that indicates whether the downlink measurements for power control shall be made on BCCH or PDCH.	0/1	1	PBCCH D/L (**)
T _{AVG_W}	Signal level filter period for power control in packet idle mode $2^{(k/2)} / 6$ multiframe, k = 0, 1, ..., 25	0-25	5	PBCCH D/L (**)
T _{AVG_T}	Signal level filter period for power control in packet transfer mode $2^{(k/2)} / 6$ multiframe, k = 0, 1, ..., 25	0-25	5	PBCCH D/L (**)
N _{AVG_I}	Interference signal level filter constant for power control $2^{(k/2)}$, k = 0, 1, ..., 15	0-15	4	PBCCH D/L (**)

(continued)

Table 3 (concluded): Radio sub-system link control parameters for GPRS

Parameter name	Description	Range	Bits	Channel
BEP_PERIOD	Filter constant for EGPRS Channel quality measurements. See subclause 10.2.3.2.1	0-15	4	PBCCH D/L (**)
BEP_PERIOD2	Filter constant for EGPRS Channel quality measurements. See subclause 10.2.3.2.1	0-15	4	PACCH D/L
INT_MEAS_CHANNEL_LIST	Channel list for interference measurements in packet idle mode	-	-	PBCCH D/L (**)
NETWORK_CONTROL_ORDER	Controls cell re-selection and measurement reporting	0-3	2	PBCCH D/L PCCCH D/L PACCH D/L (**)
NC_FREQUENCY_LIST	Frequency list for cell re-selection measurement reporting	-	-	PCCCH D/L PACCH D/L
NC_REPORTING_PERIOD_I NC_REPORTING_PERIOD_T	Time period for measurement reporting 0.48, 0.96, 1.92, ..., 61.44 seconds	0-7	3	PBCCH D/L PCCCH D/L PACCH D/L (**)
EXT_MEASUREMENT_ORDER	Controls extended measurement reporting	0-3	2	PBCCH D/L PCCCH D/L PACCH D/L
EXT_FREQUENCY_LIST	Frequency list for extended measurement reporting	-	-	PBCCH D/L PCCCH D/L PACCH D/L
EXT_REPORTING_PERIOD	Time period for measurement reporting 60, 120, 240, ..., 7680 seconds	0-7	3	PBCCH D/L PCCCH D/L PACCH D/L
EXT_REPORTING_TYPE	Defines the type of extended measurement report	1-3	2	PBCCH D/L PCCCH D/L PACCH D/L
INT_FREQUENCY	Frequency for which the MS shall include interference measurements in extended measurement report type 3	0-31	5	PBCCH D/L PCCCH D/L PACCH D/L
NCC_PERMITTED	Bit map of NCC part of BSIC for which the MS shall report extended measurements.	-	8	PBCCH D/L PCCCH D/L PACCH D/L
SCALE	Indication of the offset, which applies for the reported RXLEV values. 0 = 0 dB, 1 = +10 dB	0-1	1	PACCH U/L
SCALE_ORD	Indication of the offset, which shall be used for the reported RXLEV values. 0 = +0 dB, 1 = + 10 dB, 2 = automatic Default value = 0 dB.	0-2	2	PBCCH D/L PCCCH D/L PACCH D/L (**)
CELL_BAR_ACCESS_2 Qsearch_P	See table 3b Search for 3G cells if signal level below threshold (0-7): - 98, - 94, ... , - 74 dBm, ∞ (always) or above threshold (8-15): - 78, - 74, ... , - 54 dBm, ∞ (never). Default value = ∞ (never).	0/1 0-15	1 4	PBCCH D/L PCCCH D/L PACCH D/L (**)
XXX_GPRS_Qoffset	Applies an offset to RLA_P for cell re-selection to access technology/mode XXX (one or more), 0 = - ∞ (always select a cell if acceptable), 1 = -28 dB, 2 = -24 dB, ... , 15 = 28 dB. Default value = 0 dBm.	0-15	4	PBCCH D/L
FDD_Qmin	A minimum threshold for Ec/No for UTRAN FDD cell re-selection, 0= -20dB, 1= -6dB, 2= -18dB, 3= -8dB, 4= -16dB, 5= -10dB, 6= -14dB, 7= -12dB. Default value= -12dB.	0-7	3	PBCCH D/L
XXX_MULTIRAT_REPORTING	The number of cells from the access technology/mode XXX (one or more) that shall be included in the measurement report.	0-3	2	PBCCH D/L PCCCH D/L PACCH D/L (**)

SERVING_BAND_REPORTING	The number of cells from the GSM serving frequency band that shall be included in the measurement report.	0-3	2	PBCCH D/L PCCCH D/L PACCH D/L (**)
REPORT_TYPE	Indicates which report type the MS shall use, 0 = enhanced, 1 = normal. Default value = normal.	0/1	1	PBCCH D/L PCCCH D/L PACCH D/L (**)
REP_PRIORITY	Indicates the reporting priority per cell, 0 = normal, 1 = high	0/1	1	PBCCH D/L PCCCH D/L PACCH D/L (**)
REPORTING_RATE	Indicates the allowed reporting rate, 0 = normal, 1 = reduced	0/1	1	PBCCH D/L PCCCH D/L PACCH D/L (**)
INVALID_BSIC_REPORTING	Indicates if GSM cells with invalid BSIC and allowed NCC part may be reported, 0 = no, 1 = yes	0/1	1	PBCCH D/L PCCCH D/L PACCH D/L (**)
XXX_REPORTING_THRESHOLD	Apply priority reporting if the reported value is above threshold for GSM frequency band or access technology/mode XXX (one or more), 0, 6, ... , 36, ∞ (never). Default value = always.	0-7	3	PBCCH D/L PCCCH D/L PACCH D/L (**)
XXX_REPORTING_OFFSET	Apply an offset to the reported value when prioritising the cells for reporting for GSM frequency band or access technology/mode XXX (one or more), 0, 6, ... , 42 dB. Default value = 0 dB.	0-7	3	PBCCH D/L PCCCH D/L PACCH D/L (**)
FDD_REP_QUANT	Indicates the reporting quantity for UTRAN FDD cells, 0 = RSCP, 1 = Ec/No	0/1	1	PBCCH D/L PCCCH D/L PACCH D/L (**)
3G_SEARCH_PRIO	Indicates if 3G cells may be searched when BSIC decoding is required, 0 = no, 1 = yes. Default value = yes	0/1	1	PBCCH D/L PCCCH D/L PACCH D/L (**)
RTD	The real time difference to other GSM cells, modulo 51 TDMA frames, step: 1 or 1/64 TDMA frame	0-50 or 0-3263	6 or 12	PBCCH D/L (**)

NOTE: (**) These parameters occur also on BCCH if PBCCH does not exist.

Table 3a: Conversion from idle mode to GPRS cell re-selection parameters

GPRS Parameter name	Conversion from idle mode parameters
GPRS_RXLEV_ACCESS_MIN	RXLEV_ACCESS_MIN
GPRS_MS_TXPWR_MAX_CCH	MS_TXPWR_MAX_CCH
C31	0
GPRS_RESELECT_OFFSET(n)	CELL_RESELECT_OFFSET(n) - CELL_RESELECT_OFFSET(s)
GPRS_TEMPORARY_OFFSET	TEMPORARY_OFFSET
GPRS_PENALTY_TIME	PENALTY_TIME
PRIORITY_CLASS	0
C32_QUAL	0
GPRS_CELL_RESELECT_HYSTERESIS	CELL_RESELECT_HYSTERESIS
RA_RESELECT_HYSTERESIS	CELL_RESELECT_HYSTERESIS
XXX_GPRS_Qoffset	XXX_Qoffset

NOTE: If PENALTY_TIME = 11111 for a cell, the sign of CELL_RESELECT_OFFSET shall be changed and TEMPORARY_OFFSET set to 0 for that cell.

Table 3b: Parameters affecting cell priority for cell selection and re-selection

CELL_BAR ACCESS_2	Cell selection priority	Status for cell reselection
0	Normal	Normal
1	Barred	Barred

NOTE 1: A low priority cell is only selected if there are no suitable cells of normal priority (see 3GPP TS 03.22).

11 CTS mode tasks

11.1 CTS idle mode tasks

Whilst attempting to attach to a CTS-FP, a CTS-MS shall implement the CTS cell selection procedure described in 3GPP TS 03.22. This procedure makes use of measurements and sub-procedures described in this clause. The procedure ensures that the CTS-MS is CTS attached to a CTS cell from which it can reliably decode downlink data and where access to CTS service is allowed.

Whilst in CTS idle mode, the CTS-MS shall implement procedures reporting to the CTS-FP (AFA monitoring, BCCH detection and OFO measurement), described in 3GPP TS 03.22. These procedure makes use of measurements and sub-procedures described in this clause, and are used for the frequency control of the system, described in 3GPP TS 05.56 and 3GPP TS 05.10.

This clause makes use of terms defined in 3GPP TS 03.22.

For the purpose of CTS cell selection, the CTS-MS shall be capable of detecting and synchronizing to a CTSBCH carrier and read the CTSBCH-SB data at reference sensitivity level and reference interference levels as specified in 3GPP TS 05.05. A CTS-MS in CTS idle mode shall always fulfil the performance requirement specified in 3GPP TS 05.05 at levels down to reference sensitivity level or reference interference level.

For the purpose of CTS cell selection, the CTS-MS shall compute an average of received signal levels for the CTSBCH carrier. This quantity called 'received level average' shall be unweighted average of the received signal level measured in dBm. The accuracy of the signal level measurements for CTS cell selection and the other idle mode tasks shall be the same as for radio link measurements.

The tolerance on all the timing requirements in this subclause is $\pm 10\%$.

11.1.1 CTS cell selection

11.1.1.1 Synchronization and measurements for CTS cell selection

The CTS-MS shall store the CTSBCH ARFCN for each CTS-FP the CTS-MS is enrolled with.

In the modes where CTS cell selection is required (see 3GPP TS 03.22), for each CTS-FP the CTS-MS is enrolled with, the CTS-MS shall periodically attempt to synchronize to the stored CTSBCH carrier. When attempting to synchronize to the CTSBCH carrier, the CTS-MS shall attempt to detect the frequency correction burst of the CTSBCH-FB and when detected, to decode the synchronization burst of the CTSBCH-SB and read the CTSBCH-SB information. The CTS-MS shall calculate the received level average of the CTSBCH carrier, the averaging being based on at least five measurement samples taken on the CTSBCH bursts.

The maximum time allowed to synchronize to a CTSBCH carrier and read the CTSBCH-SB information shall be 5 seconds.

11.1.1.2 Initial synchronization of CTS-MS

In order to perform upper layer procedures, e.g. the enrolment of a CTS-MS (see 3GPP TS 04.56), a special procedure shall be implemented in the CTS-FP, by which the initial synchronization of a CTS-MS with the CTS-FP is eased. This procedure of initial synchronization of CTS-MS shall be triggered by the CTS upper layers.

The procedure consists in transmitting the CTSBCH in every TDMA frame with the following pattern :

if $FN \bmod 52 = 25$ then the CTSBCH-FB is transmitted

else

if $FN \bmod 2 = 0$ then the CTSBCH-FB is transmitted

if $FN \bmod 2 = 1$ then the CTSBCH-SB is transmitted

The first burst sent with this pattern shall be the next programmed CTSBCH-FB on the TDMA frame : $FN \bmod 52 = 25$. The above transmission pattern shall be repeated for a period of 120 52-multiframe. No CTSBCH shifting shall be allowed during the pattern: the CTSBCH timeslot number shall be the TNC, see 3GPP TS 05.02.

The CTS-MS shall attempt to synchronize to the CTSBCH transmitted with the above pattern. Once synchronized, the CTS-MS shall perform the non-hopping access procedure, e.g. for enrolment purpose (see 3GPP TS 04.56). Upon reception of the access request message by the CTS-FP, the pattern transmission shall be stopped.

11.1.2 Criterion for CTS cell selection

The path loss criterion parameter $C1_CTS$ used for CTS cell selection is defined by:

$$C1_CTS = \text{Received Level Average} - CTS_RXLEV_ACCESS_MIN$$

where: $CTS_RXLEV_ACCESS_MIN$ = Minimum received level at the CTS-MS required for access to the system; this parameter shall be given by the CTS-FP to CTS-MS during the enrolment procedure (see 3GPP TS 04.56) and shall be stored in the CTS-MS for each CTS-FP it is enrolled with. The parameter can be updated on request of the CTS-FP.

All values are expressed in dBm.

The path loss criterion (3GPP TS 03.22) is satisfied if $C1_CTS > 0$.

11.1.3 Monitoring of CTSBCH and CTSPCH

11.1.3.1 Monitoring of received signal level

Whilst in CTS idle mode, the CTS-MS shall measure the received signal level of the CTSBCH and shall calculate the received level average of the CTSBCH carrier, the averaging being a running average on at least five collected measurement samples and a maximum time of 11 seconds ($5 \cdot 9 \cdot 52$ frames). The criterion $C2_CTS$ defined below shall be calculated every time the CTS-MS decodes the CTSBCH in its CTS paging group :

$$C2_CTS = C1_CTS + CTS_CELL_RESELECT_OFFSET$$

If the criterion $C2_CTS$ falls below zero for a period of 15 seconds, the CTS-MS shall consider itself as de-attached with the CTS-FP and shall perform the CTS cell selection specified in subclause 11.1.1.

11.1.3.2 Downlink beacon failure

The downlink beacon failure criterion is based on the downlink beacon failure counter DBC. Whilst in CTS idle mode on a CTS cell, DBC shall be initialized to a value equal to the nearest integer to $90/N$ where N is the number of paging groups defined for the CTS-FP (see 3GPP TS 05.02 subclause 6.5.7). Thereafter, whenever the CTS-MS attempts to decode CTSBCH-SB information bits (see 3GPP TS 05.02): if the information bits are successfully decoded DBC is increased by 1, however never beyond the initial value, otherwise DBC is decreased by 4. When $DBC \leq 0$, a downlink beacon failure shall be declared.

If a downlink beacon failure occurs, the CTS-MS shall consider itself as de-attached with the CTS-FP and shall perform the CTS cell selection specified in subclause 11.1.1.

11.1.3.3 Downlink paging failure

The downlink paging failure criterion is based on the downlink paging failure counter DPC. Whilst in CTS idle mode on a CTS cell, DPC shall be initialized to a value equal to $CTSPCH_DECOD$ (this parameter shall be given by the CTS-FP to the CTS-MS during the attachment procedure, see 3GPP TS 04.56). Thereafter, each time the

CTS-MS is required to decode a paging message on the CTSPCH (see 3GPP TS 05.02 subclause 6.5.1 ix): if the paging message is not successfully decoded ($BFI = 1$) DPC is decreased by 1, otherwise DPC is re-initialized to CTSPCH_DECOD. When $DPC \leq 0$, a downlink paging failure shall be declared.

If a downlink paging failure occurs, the CTS-MS shall consider itself as de-attached with the CTS-FP and shall perform the CTS cell selection specified in subclause 11.1.1.

11.1.4 Procedures with reporting to the CTS-FP

Whilst in CTS idle mode, the CTS-FP may order to the CTS-MS to complete the procedures defined hereafter. The order for each procedure is sent to the CTS-MS during a dedicated connection (see 3GPP TS 04.56).

For each of the procedures, a maximum time of processing is allowed. When multiple procedures are ordered in a single dedicated connection, the results shall be ready to be reported to the CTS-FP when the time corresponding to the sum of the maximum time of each procedure has expired.

11.1.4.1 AFA monitoring

The reporting of the AFA monitoring procedure is used by the AFA algorithm for the frequency management of the CTS (see 3GPP TS 05.56).

The parameters sent by the CTS-FP to the CTS-MS in the AFA monitoring order message shall be a list of n carriers : AFA monitoring frequency list, AMFL(1,...,n), together with the number of AFA monitoring cycles NAMC to perform.

For each carrier of the AMFL, the CTS-MS shall perform NAMC basic measurements, where a basic measurement shall be the average received signal level on the 8 timeslots of the TDMA frame. The delay between two consecutive basic measurements shall be at least 5 seconds. The received interference level of the carrier shall be the maximum of the NAMC basic measurements.

The maximum processing time for this procedure shall be (NAMC x 10) seconds.

When ordered by the CTS-FP, the CTS-MS shall report in the next AFA monitoring report message a table of received interference level of the carrier of the AMFL, INTERF_LEV (1,...,n), together with the minimum of the numbers of performed AFA monitoring cycles, NAMC_REAL ; the procedure shall be stopped.

11.1.4.2 BCCH detection

The reporting of the BCCH detection procedure may be used by the CTS-FP by the AFA algorithm and for the OFO request.

The parameters sent by the CTS-FP to the CTS-MS in the BCCH detection message shall be a list of m carriers : BCCH detection frequency list, BDFL(1,...,m).

For each carrier of the list, the CTS-MS shall attempt to synchronize to it and decode the SCH. The BCCH detection shall be failed (BCCH not detected) if the CTS-MS fails to decode the SCH.

The procedure shall be completed in maximum ($m \times 10$) seconds

When ordered by the CTS-FP, the CTS-MS shall report in the next BCCH detection report message a table of BCCH detection status of the carriers of the list, BCCH_DETECT (1, ..., m) ; the procedure shall be stopped.

11.1.4.3 Observed Frequency Offset (OFO) measurement

The reported OFO measurements shall be used by the CTS-FP to correct its frequency source (see 3GPP TS 05.10).

The parameters sent by the CTS-FP to the CTS-MS in the OFO measurement message shall be a list of k BCCH carriers : OFO measurement BCCH list, OMBL(1,...,k).

For each BCCH carrier of the list, the CTS-MS shall attempt to assess the frequency offset between the BCCH carrier and the CTS-FP. The measurement status shall be "failed" if an offset measurement accuracy better than 0.2 ppm cannot be ensured.

The procedure shall be completed in maximum ($k \times 15$) seconds

When ordered by the CTS-FP, the CTS-MS shall report in the next OFO measurement report message the table of OFO measurements and measurement status of the BCCH carriers of the list : OFO_MEAS(1, ...,k), OFO_STATUS(1, ...,k) ; the procedure shall be stopped.

11.2 Intra-cell handover

11.2.1 Overall process

The overall intra-cell handover process is implemented in the CTS-MS and CTS-FP. Measurement of radio subsystem downlink performance is made in the CTS-MS. These measurements are signalled to the CTS-FP for assessment. The CTS-FP measures the uplink performance for the CTS-MS being served. Initial assessment of the measurements in conjunction with defined thresholds and intra-cell handover strategy shall be performed in the CTS-FP.

11.2.2 CTS-MS measurement procedure

A procedure shall be implemented in the CTS-MS by which it monitors the downlink RX signal level and quality from its serving CTS cell. The requirements for the CTS-MS measurements are given in subclause 11.5.

11.2.3 CTS-FP measurement procedure

A procedure shall be implemented in the CTS-FP by which it monitors the uplink RX signal level and quality from each CTS-MS being served by the CTS cell.

11.2.4 Strategy

The intra-cell handover strategy employed by the CTS-FP for radio link control determines the handover decision that will be made based on the CTS measurement results reported by the CTS-MS and made by the CTS-FP, and on various parameters set for each CTS-FP.

Due to the Total Frequency Hopping applied to the traffic channels in CTS, intra-cell handover can only occur to a different timeslot of the CTS cell.

Intra-cell handover from one timeslot in the CTS cell to another timeslot in the same CTS cell will normally be performed if the CTS measurement results show a low RXQUAL, but a high RXLEV on the serving CTS cell. This indicates a degradation of quality caused by interference even though the CTS-MS is situated within the coverage area of the serving CTS cell. The intra-cell handover should provide a timeslot with a lower level of interference.

11.3 RF power control

11.3.1 Overall process

RF power control is employed to minimize the transmit power required by CTS-MS or CTS-FP whilst maintaining the quality of the radio links. By minimizing the transmit power levels, interference to co-channel users is reduced.

11.3.2 CTS-MS implementation

RF power control shall be implemented in the CTS-MS.

The power control level to be employed by the CTS-MS on the uplink channel is indicated by means of the power control information sent either in the layer 1 header of each SACCH message block (see 3GPP TS 04.04) on the corresponding downlink channel, or in a dedicated signalling block (see 3GPP TS 04.56).

The CTS-MS shall employ the most recently commanded power control level (parameter CTS_MS_TXPWR_REQUEST) for all transmitted bursts on either a TCH, FACCH or SACCH.

The CTS-MS shall confirm the power control level that it is currently employing in the SACCH L1 header on the uplink (parameter CTS_MS_TXPWR_CONF). The indicated value shall be the power control level actually used by the CTS-MS for the last burst of the previous SACCH period.

When accessing a cell on the ARCH (CTS access request) and before receiving the first power command during a communication on a TCH (after a CTS immediate assignment message), the CTS-MS shall use the power control level defined by the CTS_MS_MAX_TXPWR parameters ; this parameters shall be given by the CTS-FP to the CTS-MS during the enrolment procedure, and can be updated on request of the CTS-FP.

If a power control level defined in 3GPP TS 05.05 is received but the level is not supported by the CTS-MS, the CTS-MS shall use the supported output power which is closest to the output power indicated by the received power control level.

11.3.3 CTS-MS power control range

The range over which a CTS-MS shall be capable of varying its RF output power shall be from its maximum authorized output power CTS_MS_MAX_TXPWR, down its lowest nominal output power (as defined in 3GPP TS 05.05), in steps of nominally 2 dB.

3GPP TS 05.05 gives a detailed definition of the RF power level step size and tolerances for a CTS-MS.

11.3.4 CTS-FP implementation

RF power control shall be implemented in the CTS-FP.

11.3.5 CTS-FP power control range

The range over which a CTS-FP shall be capable of varying its RF output power shall be from its maximum authorized output power CTS_FP_MAX_TXPWR down its lowest nominal output power (as defined in 3GPP TS 05.56), in steps of nominally 2 dB.

3GPP TS 05.56 gives a detailed definition of the RF power level step size and tolerances for a CTS-FP.

11.3.6 Strategy

The RF power control strategy employed by the CTS-FP determines the ordered power control level that is signalled to the CTS-MS, and the power control level that is employed by the CTS-FP.

The power control level to be employed in each case shall be based on the CTS measurement results reported by the CTS-MS and made by the CTS-FP, and on various parameters set for each CTS-FP.

If the CTS-MS reports in each CTS measurement results a RXQUAL_0 and a RXLEV greater or equal to 31, for a period of 30 seconds, the CTS-FP RF output power shall be at the end of this period the lowest nominal output power specified in 3GPP TS 05.56.

Under static interference free conditions, if the CTS-MS signal level received by the CTS-FP is greater or equal to -85 dBm for a period of 30 seconds, the CTS-FP shall command the CTS-MS to reduce its RF output power, so that the CTS-MS RF output power is at the end of this period the lowest nominal output power specified in 3GPP TS 05.05.

11.3.7 Timing

Upon receipt of a command from an SACCH to change its power level, the CTS-MS shall change to the new level at a rate of one nominal 2 dB power control step every 60 ms (13 TDMA frames), i.e. a range change of 15 steps should take about 900 ms. The change shall begin at the first TDMA frame belonging to the next reporting period (as specified in subclause 11.5.4). The CTS-MS shall change the power one nominal 2 dB step at a time, at a rate of one step every 60 ms following the initial change, irrespective of whether actual transmission takes place or not.

In case of intra-cell handover, the commanded power control level shall be applied on the new timeslot immediately.

11.4 Radio link failure

11.4.1 Criterion

The criterion for determining Radio Link Failure in the CTS-MS shall be based on the success rate of decoding messages on the downlink SACCH.

11.4.2 CTS-MS procedure

The aim of determining radio link failure in the CTS-MS is to ensure that calls with unacceptable voice/data quality, which cannot be improved either by RF power control or intra-cell handover, are either re-established or released in a defined manner.

The radio link failure criterion is based on the radio link counter S_CTS. If the CTS-MS is unable to decode a SACCH message (BFI = 1), S_CTS is decreased by 1. In the case of a successful reception of a SACCH message (BFI = 0) S_CTS is increased by 2. In any case S_CTS shall not exceed the value of CTS_RADIO_LINK_TIMEOUT. If S_CTS reaches 0 a CTS radio link failure shall be declared. The action to be taken is specified in 3GPP TS 04.56. The CTS_RADIO_LINK_TIMEOUT parameter is transmitted by the CTS-FP to the CTS-MS during the attachment procedure (see 3GPP TS 04.56). For the attachment or enrolment procedure, the CTS_RADIO_LINK_TIMEOUT shall be set to 64.

The CTS-MS shall continue transmitting as normal on the uplink until S_CTS reaches 0.

The algorithm shall start after the assignment of a dedicated channel and S_CTS shall be initialized to CTS_RADIO_LINK_TIMEOUT.

The detailed operation shall be as follows:

- the radio link time-out algorithm shall be stopped at the reception of a CTS intra-cell handover command;
- (re-)initialization and start of the algorithm shall be done whenever the CTS-MS switches to a new timeslot, at the latest when the main signalling link (see 3GPP TS 04.56) has been established;
- the CTS_RADIO_LINK_TIMEOUT value used at (re-)initialization shall be that used on the previous timeslot (in the CTS immediate assignment case the value stored by the CTS-MS during the attachment procedure), or the value received on SACCH if the CTS-MS has received a CTS_RADIO_LINK_TIMEOUT value on the new channel before the initialization;
- if the first CTS_RADIO_LINK_TIMEOUT value on the SACCH is received on the new channel after the initialization, the counter shall be re-initialized with the new value.

11.4.3 CTS-FP procedure

The criteria for determining radio link failure in the CTS-FP should be based upon either the error rate on the uplink SACCH or on RXLEV/RXQUAL measurements reported by the CTS-MS.

11.5 Radio link measurements

Radio link measurements are used in the intra-cell handover and RF power control processes.

The measurements are made over each SACCH multiframe, which is 104 TDMA frames (480 ms) for a TCH.

11.5.1 Signal strength

11.5.1.1 General

The received signal level may be employed as a criterion in the RF power control and intra-cell handover processes.

11.5.1.2 Physical parameter

As specified in subclause 8.1.2, measured by the CTS-MS and CTS-FP.

11.5.1.3 Statistical parameters

For each channel, the measured parameters (RXLEV) shall be the average of the received signal level measurement samples in dBm taken on that channel within the reporting period of length one SACCH multiframe defined in 11.5.4. In averaging, measurements made during previous reporting periods shall always be discarded.

When assigned a TCH, the CTS-MS shall make a received signal level measurement on all bursts of the associated physical channel (see 3GPP TS 05.02), including those of the SACCH.

For any TCH assigned to a CTS-MS, the CTS-FP shall make a received signal level measurement on all bursts of the associated physical channel including those of the SACCH.

11.5.1.4 Range of parameter

As specified subclause in subclause 8.1.4.

11.5.2 Signal quality

11.5.2.1 General

The received signal quality shall be employed as a criterion in the RF power control and intra-cell handover processes.

11.5.2.2 Physical parameter

As specified in subclause 8.2.2, measured by the CTS-MS and CTS-FP.

11.5.2.3 Statistical parameters

For each channel, the measured parameters (RXQUAL) shall be the received signal quality, averaged on that channel over the reporting period of length one SACCH multiframe defined in subclause 11.5.4. In averaging, measurements made during previous reporting periods shall always be discarded.

11.5.2.4 Range of parameter

As specified in subclause 8.2.4.

11.5.3 Aspects of discontinuous transmission (DTX)

The use of DTX is mandatory for the CTS-MS and the CTS-FP on a TCH. Not all TDMA frames may be transmitted, however, the subset specified in subclause 8.3 shall always be transmitted, and hence can be employed to assess quality and signal level during DTX.

11.5.4 Measurement reporting for the CTS-MS on a TCH

For a TCH, the reporting period of length 104 TDMA frames (480 ms) is defined in terms of TDMA frame numbers (FN) as follows:

Timeslot number (TN)	TDMA frame number (FN) modulo 104	
TCH/F	Reporting period	SACCH Message block
0 and 1	0 to 103	12, 38, 64, 90
2 and 3	26 to 25	38, 64, 90, 12
4 and 5	52 to 51	64, 90, 12, 38
6 and 7	78 to 77	90, 12, 38, 64

When on a TCH, the CTS-MS shall assess during the reporting period and transmit to the CTS-FP in the next SACCH message block the following:

- CTS_RXLEV_FULL_SERVING_CELL and CTS_RXQUAL_FULL_SERVING_CELL :
RXLEV_FULL and RXQUAL_FULL for the full set of TCH and SACCH TDMA frames. The full set of TDMA frames is 100 (i.e. 104 - 4 idle) frames for a full rate TCH;
- CTS_RXLEV_SUB_SERVING_CELL and CTS_RXQUAL_SUB_SERVING_CELL:
RXLEV_SUB and RXQUAL_SUB for the subset of 4 SACCH frames and the SID TDMA frames/L2 fill frames defined in 8.3. If no FACCH frames have been received at the corresponding frame positions, the RXQUAL_SUB report shall include measurements on the 4 SACCH frames only. The performance requirements of subclause 8.2.4 do not apply in this case for RXQUAL_SUB.

If the next SACCH message block is used for a different Layer 3 message, the averaged data which would otherwise be sent in that block is discarded and a new average started for the current block. i.e., any SACCH message will report the average data for the previous reporting period only.

The CTS-MS shall also transmit a bit (CTS_DTX_USED) in the next SACCH message block, which indicates whether or not it has employed DTX during the reporting period. This bit shall be set even if just one burst in a TDMA frame in the reporting period was not transmitted due to DTX.

NOTE: A speech frame subject to DTX may cross the "border" between two reporting periods, in which case both of the associated SACCH message blocks will have the CTS_DTX_USED flag set.

11.6 Control of CTS-FP service range

In order to restrict the CTS-FP service range, the CTS-FP shall monitor the delay of the signal sent by from the CTS-MS. For each CTS-MS the CTS-FP has allocated a TCH, a range measurement of the CTS-MS shall be computed by the CTS-FP every five reporting period by averaging over five reporting periods the assessed delay (as specified in 3GPP TS 05.10) for each received TCH burst of the subset always to be transmitted, specified in subclause 8.3, and for each received SACCH burst.

The TCH shall be released by the CTS-FP if two consecutive range measurements are greater than 1 bit period.

11.7 Control parameters

The parameters employed to control the radio link are shown in table 4, 5 and 6.

Table 4: Radio subsystem link control general parameters

Parameter name	Description	Range	Bits
CTS_FP_MAX_TXPWR	The maximum authorized output power control level the CTS-FP shall use (downlink)	0-31	5
CTS_MS_MAX_TXPWR	The maximum authorized output power control level a CTS-MS shall use with this CTS cell (uplink)	0-31	5
CTS_RXLEV_ACCESS_MIN	Minimum received level at the CTS-MS required for access to the system : coded as a RXLEV value (see subclause 8.1.4)	0-63	6
CTS_CELL_RESELECT_OFFSET	Applies an offset to the C2_CTS criterion : 0-63 dB in 63 steps of 1 dB	0-63	6
CTS_RADIO_LINK_TIMEOUT	The maximum value of the radio link counter : 4-64 SACCH blocks, in 15 steps of 4 SACCH blocks	0-15	4
CTSPCH_DECOD	Number of non-decoded paging messages before declaring a downlink paging failure	1-255	8

Table 5: AFA monitoring, BCCH detection and OFO measurement control parameters - dedicated connection

Parameter name	Description	Range	Bits	Message
AMFL (1-n)	AFA monitoring frequency list : contains n carriers represented by their ARFCN	0-1023	10	AFA monitoring order
NAMC	Number of AFA monitoring cycles	0-1023	10	AFA monitoring order
INTER_LEV (1-n)	Received interference level per carrier of the AMFL : coded as a RXLEV value (see subclause 8.1.4)	0-63	6	AFA monitoring report
NAMC_REAL	Minimum of the numbers of performed AFA monitoring cycles	0-1023	10	AFA monitoring report
BDFL (1-m)	BCCH detection frequency list : contains m carriers represented by their ARFCN	0-1023	10	BCCH detection order
BCCH_DETECT (1-m)	BCCH detection status : 00 : detected 01 : not detected 11 : not attempted	-	2	BCCH detection report
OMBL (1-k)	OFO measurement BCCH list : contains k BCCH carriers represented by their ARFCN	0-1023	10	OFO measurement order
OFO_MEAS (1-k)	OFO measurements list : 0.05 - 6.4 ppm in 127 steps of 0.05 ppm	0-127	7	OFO measurement report
OFO_STATUS (1-k)	OFO measurement status : 00 : measurement OK 01 : measurement failed 11 : measurement not attempted	-	2	OFO measurement report

Table 6: Intra-cell handover and power control parameters - SACCH

Parameter name	Description	Range	Bits	Message
CTS_MS_TXPWR_REQUEST (ordered MS power level)	The power level to be used by a CTS-MS	0-31	5	L1 header downlink
CTS_MS_TXPWR_CONF. (actual CTS-MS power level)	Indication of the power level in use by the CTS-MS.	0-31	5	L1 header uplink
CTS_POWER_LEVEL	The power level to be used by a CTS-MS on the indicated channel	0-31	5	CTS HO/assignment command
CTS_RXLEV_FULL_SERVING_CELL	The RXLEV in the current serving CTS cell accessed over all TDMA frames	0-63	6	CTS Measurement results
CTS_RXLEV_SUB_SERVING_CELL	The RXLEV in the current serving CTS cell accessed over a subset of TDMA frames	0-63	6	CTS Measurement results
CTS_RXQUAL_FULL_SERVING_CELL	The RXQUAL in the current serving CTS cell, assessed over all TDMA frames.	0-7	3	CTS Measurement results
CTS_RXQUAL_SUB_SERVING_CELL	The RXQUAL in the current serving CTS cell, assessed over subset of TDMA frames.	0-7	3	CTS Measurement results
CTS_DTX_USED	Indicates whether or not the CTS-MS used DTX during the previous measurement period.	-	1	CTS Measurement results

NOTE 1: RXLEV and RXQUAL fields are coded as described in subclause 11.6.

NOTE 2: For the details of the CTS Measurement Result message see 3GPP TS 04.56.

12 COMPACT Mode Tasks

12.1 Introduction

COMPACT is a radio interface mode for inter cell synchronized systems. The mapping of control channels for up to four cells is done on the same carrier and control channel separation is achieved by transmitting control in different cells on different timeslots. The mapping of the control channels is specified in 3GPP TS 05.02.

The COMPACT Mode Tasks defined in this clause applies for COMPACT capable MSs in cells employing a CPBCCCH carrier as defined in 3GPP TS 05.02. The COMPACT Mode Tasks also applies for MSs in any cell, where at least one CPBCCCH is defined in a BA list.

Note: A mobile stations designed prior to release 99 will not find CPBCCCH carriers when it is looking for a BCCH carrier due to the different structure of synchronization and frequency bursts.

12.2 Network Pre-requisites

12.2.1 CPBCCCH carriers

The CPBCCCH carrier shall be transmitted with constant RF output power on at least 4 radio blocks per multiframe on the serving time group (see 3GPP TS 05.02).

12.3 COMPACT Idle Mode Tasks

12.3.1 Introduction

Whilst in idle mode, a COMPACT capable MS shall implement cell selection and cell reselection procedures as described in 3GPP TS 03.22. These procedures make use of measurements and sub-procedures described in this clause.

The procedures ensure that the MS is camped on a cell from which it can reliably decode downlink data and with which it has a high probability of communications on the uplink. Once the MS is camped on a cell, access to the network is allowed.

The MS shall not use the discontinuous reception (DRX) mode of operation (i.e., powering itself down when it is not expecting paging messages from the network) while performing cell selection algorithms defined in 3GPP TS 03.22. However, use of powering down is permitted at all other times in idle mode.

12.3.2 Measurements for COMPACT Cell Selection

An MS shall in the COMPACT Cell selection procedure search for CPBCCCH carriers. The MS shall search all RF channels in the system within its band of operation, take readings of received RF signal level of each RF channel, and calculate the RLA_P for each. Each reading of received RF signal level shall be performed in such a way that it corresponds to the RF level at occurrences when the potential CPBCCCH carrier is transmitting CPBCCCH, CSCH, CFCCCH or CPBCCCH blocks. Since the CPBCCCH carrier is discontinuous, a single random measurement will not suffice. A single reading may instead consist of taking the maximum value out of multiple measurements. The succeeding averaging is based on at least five such measurement readings per RF carrier, where the readings are at least 1 s apart. This procedure is referred to as a CPBCCCH scan.

NOTE: It is allowed to only take readings of RF signal level of CPBCCCH carriers if identified.

CPBCCCH carriers may be identified, for example, by searching for frequency correction bursts and then synchronizing to and reading the synchronization bursts at the prescribed offset from the PFCCH bursts (see 3GPP TS 05.02). On finding a CPBCCCH carrier, the MS shall attempt to read the CPBCCCH data, taking into account that the actual timeslot allocation of the CPBCCCH will change from multiframe to multiframe.

The maximum time allowed for synchronization to a CPBCCCH carrier is 2.5 seconds. The maximum time allowed to read each system information message, when being synchronized to the CPBCCCH, is the time it takes to complete a broadcast cycle of that message.

12.3.3 Measurements for COMPACT Stored List Cell Selection

The MS may include storage of CPBCCCH carrier information when switched off as detailed in 3GPP TS 03.22. The CPBCCCH list may include CPBCCCH carriers from more than one band in a multi band operation PLMN. A MS may also store CPBCCCH carriers for more than one PLMN which it has selected previously (e.g. at national borders or when more than one PLMN serves a country), in which case the CPBCCCH carrier lists must be kept quite separate. The stored BCCH carrier information used by the MS may be derived by a variety of different methods. As a minimum, the MS shall store the last used HPLMN CPBCCCH carriers. A memory shall host at least the 24 last CPBCCCH carriers from the HPLMN that the MS has camped on.

For a stored CPBCCCH carrier list of the selected PLMN an MS shall perform the same measurements as in subclause 12.3.2 except that only the CPBCCCH carriers in the list need to be measured.

NOTE: If the selected PLMN is equal to one of the equivalent PLMNs, then stored list cell selection applies to all equivalent PLMNs.

If stored list cell selection is not successful, then as defined in 3GPP TS 03.22, normal cell selection shall take place. Since information concerning a number of channels is already known to the MS, it may assign high priority to measurements on the strongest carriers from which it has not previously made attempts to obtain CPBCCCH information, and omit repeated measurements on the known ones.

12.3.4 Criteria for COMPACT Cell Selection

The path loss criterion parameter C1 used for cell selection and reselection when in a COMPACT cell is defined by:

$$C1 = (A - \text{Max}(B, 0))$$

where

A = RLA_P - GPRS_RXLEV_ACCESS_MIN

B = GPRS_MS_TXPWR_MAX_CCH - P

GPRS_RXLEV_ACCESS_MIN= Minimum received signal level at the MS required for access to the system.

GPRS_MS_TXPWR_MAX_CCH= Maximum TX power level an MS may use when accessing the system until otherwise commanded.

P= Maximum RF output power of the MS.

All values are expressed in dBm.

The path loss criterion (3GPP TS 03.22) is satisfied if $C1 > 0$.

12.3.5 Downlink Signalling Failure

As defined for GPRS in subclause 6.5.

12.4 COMPACT Cell Reselection

In GPRS Standby and Ready states, cell reselection is performed by the MS. The cell reselection procedures defined in this subclause apply when an MS is attached in a cell with a CPBCCCH carrier or monitors a cell with a CPBCCCH (or both). Otherwise, the MS shall perform cell re-selection according to subclause 10.1, or if PBCCH does not exist according to subclause 6.6.

The cells to be monitored for cell re-selection, referred to as neighbour cells, are defined in the BA (GPRS) list, which is broadcast on PBCCH or CPBCCCH. If PBCCH or CPBCCCH does not exist, BA(GPRS) is equal to BA(BCCH).

12.4.1 Monitoring the received signal level and CPBCCCH data

The MS shall measure the received RF signal level on the CPBCCCH or BCCH carriers of the serving cell and the surrounding cells as indicated in the BA(GPRS) list and optionally the NC_FREQUENCY_LIST, and calculate the received level average (RLA_P) for each carrier.

In addition the MS shall verify the BSIC of the neighbour cells. Only cells with allowed BSIC shall be considered for re-selection. The allowed BSIC is either a valid BSIC or, for cells in BA(BCCH) where no BSIC is broadcast, a BSIC with allowed NCC part, (see subclause 7.2). A valid BSIC is a BSIC broadcast for that carrier in the BA(GPRS) list.

12.4.1.1 Packet idle mode

Whilst in packet idle mode an MS shall continuously monitor all BCCH and CPBCCCH carriers as indicated by the BA(GPRS) list in the system information of the serving cell. Note that both BCCH and CPBCCCH carriers may be defined in the BA(GPRS) list. At least one received signal level measurement sample on each neighbour cell shall be taken for each paging block monitored by the MS according to its current DRX mode and its paging group. As the minimum MS shall take one measurement for each BCCH or CPBCCCH carrier for every 4 second. As the maximum, the MS is however not required to take more than 1 samples per second for each neighbour cell. For CPBCCCH carriers, only the TDMA frames where common control or broadcast blocks are transmitted are used for monitoring signal levels, see subclause 12.3.2.

RLA_P shall be a running average determined using samples collected over a period of 5 s to Max {5s, five consecutive paging blocks of that MS}, and shall be maintained for each BCCH or CPBCCCH carrier. The same number of measurement samples shall be taken for all neighbour cells, and the samples allocated to each carrier shall as far as possible be uniformly distributed over the evaluation period. At least 5 received signal level measurement samples are required for a valid RLA_P value.

The list of the 6 strongest non-serving cells shall be updated at a rate of at least once per running average period.

The MS shall attempt to check the BSIC for each of the 6 strongest non-serving cells at least every 14 consecutive paging blocks of that MS or 10 seconds, whichever is greater. If a change of BSIC is detected then the cell shall be treated as a new cell.

When requested by the user, the MS shall determine which PLMNs are available as described in subclause 6.6.1. However, for MSs without DRX or with short DRX period (see 3GPP TS 05.02), considerable interruptions to the monitoring of PPCH can not be avoided.

12.4.1.2 Packet transfer mode

Whilst in packet transfer mode a MS shall continuously monitor all BCCH or CPBCCCH carriers as indicated by the BA(GPRS) list and the broadcast carrier of the serving cell. In every TDMA frame possible, a received signal level measurement sample shall be taken on at least one of the BCCH carriers or CPBCCCH time groups, one after another, as evenly distributed as possible among the neighbours. As an exception for CPBCCCH carriers on multislot allocations the MS shall take at least 4 received signal level measurement samples for CPBCCCH carriers from two different time groups (2 samples/time group) in every 52 multiframe, as evenly distributed as possible among the neighbours. For CPBCCCH carriers, only the TDMA frames where common control or broadcast blocks are transmitted are used for monitoring signal levels, see subclause 12.3.2.

RLA_P shall be a running average determined using samples collected over a period of 5 s, and shall be maintained for each BCCH and CPBCCCH carrier. The samples taken on each carrier shall as far as possible be uniformly distributed over the evaluation period. At least 5 received signal level measurement samples are required for a valid RLA_P value.

The MS shall attempt to check the BSIC for as many non-serving cells as possible and as often as possible, and at least every 10 seconds. The MS shall use TDMA frame 51 of the PDCH multiframe for checking BSICs of CPBCCCH carriers and TDMA frame 25 or 51 for checking BSIC of BCCH carriers. These frames are termed search frames. A list containing BSIC and timing information for these strongest carriers at the accuracy required for accessing a cell (see 3GPP TS 05.10) including the absolute times derived from the parameters T1, T2 T3 or R1, R2, TG shall be kept by the MS. This information may be used to schedule the decoding of BSIC and shall be used when re-selecting a new cell in order to keep the switching time at a minimum. When a BCCH or CPBCCCH carrier is found to be no longer among the reported, BSIC and timing information shall be retained for 10 seconds. (This is in case a cell re-selection command to this cell is received just after the MS has stopped reporting that cell, see subclause 10.1.4.2).

If, after averaging measurement results over 4 PDCH multiframes (1 sec), the MS detects one or more BCCH or CPBCCCH carrier, among the 6 strongest, whose BSICs are not currently being assessed, then the MS shall as a matter of priority decode their BSICs.

The MS shall be able to send the first packet random access (PRACH) at the latest $5+x$ seconds after a new strongest cell (which is part of the BA(GPRS)) has been activated under the following network conditions: Initial serving cell at $RXLEV = -70$ dBm, with 6 neighbours at $RXLEV = -75$ dBm. Then the new CPBCCCH or BCCH carrier is switched on at $RXLEV = -60$ dBm. x is the longest time it may take to receive the necessary system information on CPBCCCH or BCCH in the new cell.

NOTE: Because of test equipment limitations it is acceptable to activate the new carrier to replace one of the 6 neighbours.

In the case of a multiband MS, the MS shall attempt to decode the BSIC, if any BCCH or CPBCCCH carrier with unknown BSIC is detected among the number of strongest CPBCCCH carriers in each band as indicated by the Multiband Reporting parameter (see subclause 8.4.3).

Thus an MS shall, for a period of up to 5 seconds, devote all search frames to attempting to decode these BSICs. If this fails then the MS shall return to confirming existing BSICs. Having re-confirmed existing BSICs, if there are still BCCH or CPBCCCH carriers, among the six strongest, with unknown BSICs, then the decoding of these shall again be given priority for a further period of up to 5 seconds.

If either no BSIC can be decoded on a surrounding cells, or the BSIC is not allowed, then the received signal level measurements on that channel shall be discarded and the MS shall continue to monitor that channel.

If a change of BSIC is detected on a carrier, then any existing received signal level measurement shall be discarded and the carrier shall be treated as a new carrier.

If the BSIC cannot be decoded at the next available opportunities re-attempts shall be made to decode this BSIC. If the BSIC is not decoded for more than three successive attempts it will be considered lost and any existing received signal level measurement shall be discarded and the MS shall continue to monitor that carrier.

12.4.2 COMPACT cell reselection criteria

The COMPACT GPRS mode cell reselection criteria follows the GPRS cell reselection criteria described in subclause 10.1.2.

12.4.3 COMPACT cell reselection algorithm

The cell reselection algorithm for COMPACT follows the procedures described for GPRS in subclause 10.1.3.

12.4.4 Network controlled Cell reselection

The network controlled cell reselection for COMPACT follows the procedures described for GPRS in subclause 10.1.4.

12.4.5 COMPACT cell reselection measurement opportunities

COMPACT utilizes a timeslot mapping of control channel in a rotating fashion as described in 05.02. With this timeslot rotation, a mobile can make COMPACT neighbour cell measurements of all four time-groups. The timeslot that an MS can use for measurements is dependent on the timeslot number used for traffic. During one 52-multiframe, the MS is able to measure one time-group on up to 4 frequencies once per control block. During 1 s time period (4 multiframes), the MS is able to measure all 4 time-groups.

The CPBCCCH carrier shall be transmitted with constant RF output power as defined in subclause 12.2.1, during a minimum number of control blocks. The actual number of control blocks transmitted with constant RF output power in a neighbour cell is indicated in the neighbour cell parameter `GUAR_CONST_PWR_BLKS`, broadcast in with the neighbour cell description for an EGPRS neighbour cell.

Annex A (informative): Definition of a basic GSM or DCS 1 800 handover and RF power control algorithm

A.1 Scope

This annex specifies a basic overall handover algorithm and RF power control process that may be implemented in the GSM or DCS 1 800 system.

The specification includes a set of algorithms that are sufficient to allow the successful implementation of an initial GSM or DCS 1 800 system, and from which more complex algorithms may be developed.

The basic solution is not mandatory for network operators.

A.2 Functional requirement

The present algorithm is based on the following assumptions:

- single cell BSS;
- the necessity to make a handover according to radio criteria is recognized in the BSS. It can lead to either an (internal) intracell handover or an intercell handover;
- evaluation of a preferred list of target cells is performed in the BSS;
- cell allocation is done in the MSC;
- intracell handover for radio criteria (interference problems) may be performed directly by the BSS;
- the necessity to make a handover because of traffic reason (network directed handover) is recognized by the MSC and it is performed by sending a "handover candidate enquiry message" to BSS;
- the RF power control algorithm shall be implemented in order to optimize the RF power output from the MS (and BSS if power control is implemented) ensuring at the same time that the signal level received at the BSS (MS) is sufficient to keep adequate speech/data quality;
- all parameters controlling the handover and power control processes shall be administered on a cell by cell basis by means of O&M. The overall handover and power control process is split into the following stages:
 - i) BSS pre-processing and threshold comparisons;
 - ii) BSS decision algorithm;
 - iii) MSC cell allocation algorithm.

A BSS decision algorithm is specified such that the BSS can fulfil the mandatory requirement of being able to produce a preferred list of target cells for handover.

It should be noted that since measurement results can also be sent to the MSC in the "handover required" message, the handover decision algorithm may be implemented in either the MSC or the BSS.

A.3 BSS pre-processing and threshold comparisons

For the purpose of handover and RF power control processing, the BSS shall store the parameters and thresholds shown in table A.1. These shall be administered on a cell by cell basis and downloaded to the BSS by O&M procedures.

The parameters and thresholds related to the downlink power control process are stored and used only if BSS RF power control is implemented.

The following measurements shall be continuously processed in the BSS:

- i) Measurements reported by MS on SACCH:
 - Down link RXLEV;
 - Down link RXQUAL;
 - Down link surrounding cell RXLEV (RXLEV_NCELL (n) on BCCH as indicated in the BCCH Allocation).
- ii) Measurements performed in BTS:
 - Uplink RXLEV;
 - Uplink RXQUAL;
 - MS-BTS distance;
 - Interference level in unallocated time slots.

Every SACCH multiframe (480 ms) a new processed value for each of the measurements shall be calculated.

A.3.1 Measurement averaging process

The BSS shall be capable of pre-processing the measurements by any of the following processes:

- Unweighted average;
- Weighted average, with the weightings determined by O&M;
- Modified median calculation, with exceptionally high and low values (outliers) removed before the median calculation.

The timing of the processing shall be controlled by parameters, set by O&M, as follows:

- a) RXLEV_XX (XX = DL or UL):

For every connection and for both links at least the last 32 samples shall be stored (a sample is the value evaluated by the MS and BSS during a period of 480 ms). Every 480 ms, with these samples, the BSS shall evaluate the averaged value of the received power as defined by the parameters Hreqave and Hreqt, applicable to RXLEV.

- b) RXLEV_DL on BCCH carriers (RXLEV_NCELL (n)):

For every connection and for each of up to 16 defined cells the BSS shall store the values related to the last 32 samples. The BSS shall average these samples as defined by the parameters Hreqave, Hreqt, applicable to RXLEV.

- c) RXQUAL_XX (XX = DL or UL):

For every connection and for both links at least 32 samples shall be stored (a sample is the value calculated by the MS and BSS during period of 480 ms). Every 480 ms, with these samples, the BSS shall evaluate the received signal quality as defined by the parameters Hreqave and Hreqt, applicable to RXQUAL.

- d) MS-BTS distance:

For every connection the BSS shall average the adaptive frame alignment value as defined by the parameters Hreqave and Hreqt, to derive an estimate of the MS-BTS distance.

- e) Interference level in unallocated time slots:

The BSS shall average the interference level in unallocated timeslots as defined by the *Intave* parameter. The averaged results shall be mapped into five interference categories (see 3GPP TS 08.08) whose limit *O-X5* are adjusted by O&M.

f) Power Budget:

This assessment process may be employed by the network as a criterion in the handover process, by setting a flag in the BSS by O&M command. If the process is employed, every 480 ms, for every connection and for each of allowable 32 adjacent cells, the BSS shall evaluate the following expression:

$$\text{PBG T}(n) = (\text{Min}(\text{MS_TXPWR_MAX}, P) - \text{RXLEV_DL} - \text{PWR_C_D}) - (\text{Min}(\text{MS_TXPWR_MAX}(n), P) - \text{RXLEV_NCELL}(n))$$

Where the values of *RXLEV_NCELL*(*n*) and *RXLEV_DL* are obtained with the averaging processes defined above. *PWR_C_D* is the difference between the maximum downlink RF power permitted in the cell and the actual downlink power due to the BSS power control. *MS_TXPWR_MAX* is the maximum RF TX power an MS is permitted to use on a traffic channel in the serving cell. *MS_TXPWR_MAX*(*n*) is the maximum RF TX power an MS is permitted to use on a traffic channel in adjacent cell *n*. *P* is the maximum TX power capability of the MS.

g) *Hreqave* and *Hreqt*:

The values of *Hreqt* and *Hreqave* are defined by O&M for each cell for the averaging of reported measurements. The values of *Hreqave* and *Hreqt* can be different for each of the parameters being averaged.

Hreqave:

defines the period over which an average is produced, in terms of the number of SACCH blocks containing measurement results, i.e. the number of measurements contributing to each averaged measurement.

Hreqt:

is the number of averaged results that are maintained.

The BSS shall support values of *Hreqave* and *Hreqt* such that

$$0 < \text{Hreqav} < 32$$

$$\text{and } 0 < \text{Hreqt} < 32$$

$$\text{where } \text{Hreqave} * \text{Hreqt} < 32$$

A.3.2 Threshold comparison process

A.3.2.1 RF power control process

Every SACCH multiframe, the BSS shall compare each of the processed measurements with the relevant thresholds. The threshold comparison processes and the actions to be taken are as follows:

a) Comparison of *RXLEV_XX* with *L_RXLEV_XX_P* (*XX* = DL or UL)

The algorithm shall be applied to the averaged *RXLEV* values (defined in subclause A.3.1:a). The comparison process shall be defined by the parameters *P1* and *N1* as follows:

- Increase *XX_TXPWR* if at least *P1* averages out of *N1* averages are lower than *L_RXLEV_XX_P*. (e.g. *P1* = 10 and *N1* = 12)

b) Comparison of *RXLEV_XX* with *U_RXLEV_XX_P* (*XX* = DL or UL)

The algorithm shall be applied to the averaged *RXLEV* values (defined in subclause A.3.1:a). The comparison process shall be defined by the parameters *P2* and *N2* as follows:

- Decrease *XX_TXPWR* if at least *P2* averages out of *N2* averages are greater than *U_RXLEV_XX_P*. (e.g. *P2* = 19 and *N2* = 20)

- c) Comparison of $RXQUAL_XX$ with $L_RXQUAL_XX_P$ ($XX = DL$ or UL)

The algorithm shall be applied to the averaged $RXQUAL$ values (defined in subclause A.3.1:c) The comparison process shall be defined by the parameters $P3$ and $N3$ as follows:

- Increase XX_TXPWR if at least $P3$ averaged values out of $N3$ averaged values are greater (worse quality) than $L_RXQUAL_XX_P$. (e.g. $P3 = 5$ and $N3 = 7$)

- d) Comparison of $RXQUAL_XX$ with $U_RXQUAL_XX_P$ ($XX = DL$ or UL) The algorithm shall be applied to the averaged $RXQUAL$ values (defined in subclause A.3.1:c) The comparison process shall be defined by the parameters $P4$ and $N4$ as follows:

- Decrease XX_TXPWR if at least $P4$ averaged values out of $N4$ averaged values are lower (better quality) than $U_RXQUAL_XX_P$. (e.g. $P4 = 15$, $N4 = 18$)

A.3.2.2 Handover Process

Every SACCH multiframe, the BSS shall compare each of the processed measurements with the relevant thresholds. The threshold comparison processes and the actions to be taken are as follows:

- a) Comparison of $RXLEV_XX$ with $L_RXLEV_XX_H$ ($XX = DL$ or UL)

The algorithm shall be applied to the averaged $RXLEV$ values (defined in subclause A.3.1:a). The comparison process shall be defined by the parameters $P5$ and $N5$ as follows:

- If at least $P5$ averaged values out of $N5$ averaged values are lower than $L_RXLEV_XX_H$ a handover, cause XX_RXLEV , might be required. (e.g. $P5 = 10$ and $N5 = 12$).

- b) Comparison of $RXQUAL_XX$ with $L_RXQUAL_XX_H$ ($XX = DL$ or UL)

The algorithm shall be applied to the averaged $RXQUAL$ values (defined in subclause A.3.1:c) The comparison process shall be defined by the parameters $P6$ and $N6$ as follows:

- If at least $P6$ averaged values out of $N6$ averaged values are greater (worse quality) than $L_RXQUAL_XX_H$ a handover, cause XX_RXQUAL , might be required. (e.g. $P6 = 5$ and $N6 = 7$).

- c) Comparison of $RXLEV_XX$ with $RXLEV_XX_IH$ ($XX = DL$ or UL)

The algorithm shall be applied to the averaged $RXLEV$ values (defined in subclause A.3.1:a). The comparison process shall be defined by the parameters $P7$ and $N7$ as follows:

- If at least $P7$ averaged values out of $N7$ averaged values are greater than $RXLEV_XX_IH$ an internal handover might be required if $RXQUAL_XX$ is also greater (worse quality) than $L_RXQUAL_XX_H$ (e.g. $P7 = 10$ and $N7 = 12$).

- d) Comparison of MS-BTS distance with the MAX_MS_RANGE

This comparison process may be employed by the network as a criterion in the handover process by setting a flag in the BSS by O&M. If the process is employed, the algorithm shall be applied to the averaged values defined in subclause A.3.1:d. The comparison process shall be defined by the parameters $P8$ and $N8$ as follows:

- If at least $P8$ averaged values out of $N8$ values are greater than MS_RANGE_MAX a handover, cause $DISTANCE$, might be required. (e.g. $P8 = 8$ and $N8 = 10$).

- e) Comparison of $PBGT(n)$ with the $HO_MARGIN(n)$

If the process is employed, the action to be taken is as follows:

- If $PBGT(n) > 0$ and $PBGT(n) > HO_MARGIN(n)$ a handover, cause $PBGT(n)$, might be required.

This comparison enables handover to be performed to ensure that the MS is always linked to the cell with the minimum path loss, even though the quality and signal level thresholds may not have been exceeded.

A.4 BSS decision algorithm

Recognizing the necessity to request a handover the BSS shall send a "handover required message" to the MSC containing the preferred list of target cells.

The "handover required message" shall be also generated in answer to a "handover candidate enquiry message" sent by the MSC.

The BSS decision algorithm shall be based on the following strategy:

$$RXLEV_NCELL(n) > RXLEV_MIN(n) + \text{Max}(O, P_a) \quad (1)$$

where: $P_a = (MS_TXPWR_MAX(n) - P)$

$$(\text{Min}(MS_TXPWR_MAX, P) - RXLEV_DL - PWR_C_D) - (\text{Min}(MS_TXPWR_MAX(n), P) - RXLEV_NCELL(n) - HO_MARGIN(n)) > 0 \quad (2)$$

All these expressions shall be evaluated using the averaged values defined by the parameters $Hreq_t$ and $Hreq_{ave}$.

The BSS shall evaluate the equation (2) for each of the adjacent cells that satisfies the expression (1) and shall compile the list of the preferred adjacent cells ordinated depending on the value of equation (2) (i.e. in the first position is the cell for which the value is the maximum, in the second position is the cell with the second best value and so on).

If there are any adjacent cells for which the values of $RXLEV_MIN(n)$, $HO_MARGIN(n)$ and $MS_TXPWR_MAX(n)$ are not known, i.e. the MS has reported values from an undefined adjacent cell, then the default parameters shall be used to evaluate equations 1 and 2, i.e. $RXLEV_MIN_DEF$, HO_MARGIN_DEF , $MS_TXPWR_MAX_DEF$. This enables handover to occur in situations where a call is set up in unexpected coverage area of a cell, without defined adjacent cells.

If there are several cells that satisfy the equation (2) with the same results, the first cell in the list will be that one with the best "positive trend". The trend shall be evaluated by the BSS using the last $Hreq_t$ averaged values of $RXLEV_NCELL(n)$.

If the handover is considered imperative, that is one of the following events is verified as the cause:

- a) the power level (UL and/or DL) is below the thresholds despite power control (the MS or/and the BSS have reached the maximum allowed power);
- b) the quality of the link (UL and/or DL) is below the threshold while at the same time the $RXLEV$ approximates the threshold;
- c) the distance between MS and BTS exceeds the MAX_MS_RANGE .

The list of the preferred cells shall be compiled including any candidates for which the result of the equation (2) is lower than 0. Also in this case the list shall be compiled in a decreasing order of priority.

A.4.1 Internal intracell handover according to radio criteria: (Interference problems)

The two conditions $RXQUAL_XX > L_RXQUAL_XX_H$ (bad quality) and $RXLEV_XX > RXLEV_XX_IH$, if verified at the same time, indicate a high probability of the presence of co-channel interference.

This situation can be solved by changing the channel within the cell with an intracell handover.

If internal intracell handover is supported by the BSS it shall be performed as described in 3GPP TS 08.08.

If the BSS does not support internal intracell handover, then the handover shall be initiated by sending a "handover required message" to the MSC in which the serving cell is indicated as first priority.

A.4.2 Internal handover according to other criteria

Apart from radio criteria there are other criteria that may require internal handover:

- O&M criteria;
- Resource management criteria.

In these cases, internal handover shall be triggered by the OMC or by the resource management of the BSS.

A.4.3 General considerations

Since the RF power control process and the handover process are closely linked, particular care shall be taken in order to avoid undesired interactions between them.

In particular, the following interactions should be avoided, where possible:

- a "power increase command" or a "handover for RXLEV or for RXQUAL" subsequent to a "power reduction command" (e.g. by checking that the averaged power level reduced by the Pow_Red_Step_Size plus the tolerances is greater than the L_RXLEV_XX_P or L_RXLEV_XX_H);
- a "power reduction command" subsequent to a "power increase command".

After an action of power control the set of samples related to the previous power level, in the corresponding link, shall not be used in the processing.

If, during the decision process, the condition for the "handover required message" is satisfied at the same time by different reasons. The "cause field" in the "handover required message" sent to the MSC, shall contain the reasons taking account of the following order of priority:

- RXQUAL;
- RXLEV;
- DISTANCE;
- PBGT.

A.5 Channel allocation

As described in 3GPP TS 08.08 the available channels shall be divided into five interference categories whose limits O-X5 are adjusted by O&M command.

For handover, the channel allocated should be from the category with the lowest interference level, since determination of the expected value of C/I is not possible by the new BSS.

A.6 Handover decision algorithm in the MSC

The MSC shall select the cell to which an MS is to be handed over by the following criteria:

- Handover for radio criteria shall be handled taking into account the following order of priority:
 - RXQUAL;
 - RXLEV;
 - DISTANCE;
 - PBGT.

e.g. if there are more handover bids to a cell than there are free traffic channels, then the bids with cause "RXQUAL" shall take highest priority.

- In order to avoid overload in the network, for every cell and with reference to each of 16 adjacent cells, it shall be possible to define (by O&M) for each adjacent cell one of at least 8 priority levels. These shall be considered together with the list of candidates and the interference levels in the choice of the new cell. For example, if there are two cells which meet the criteria for handover, then the cell with the highest priority shall be used. This enables umbrella cells, for instance, to be given a lower priority, and only handle calls when no other cell is available.
- Channel congestion on the best cell shall cause the choice of the second best cell, if available, and so on. If no cell is found and call queuing is employed in the MSC, then the MSC shall queue the request on the best cell for a period equal to H_INTERVAL (H_INTERVAL < T_Hand_RQD shall be set by O&M). This handover shall have priority over the queue handling new calls.

Table A.1: Parameters and thresholds stored for handover purposes

L_RXLEV_UL_P	RXLEV threshold on the uplink for power increase. Typical range - 103 to - 73 dBm.
U_RXLEV_UL_P	RXLEV threshold on the uplink for power reduction.
L_RXQUAL_UL_P	RXQUAL threshold on the uplink for power increase.
U_RXQUAL_UL_P	RXQUAL threshold on the uplink for power reduction.
L_RXLEV_DL_P	RXLEV threshold on the downlink for power increase. Typical range - 103 to - 73 dBm.
U_RXLEV_DL_P	RXLEV threshold on the downlink for power reduction.
L_RXQUAL_DL_P	RXQUAL threshold on the downlink for power increase.
U_RXQUAL_DL_P	RXQUAL threshold on the downlink for power reduction.
L_RXLEV_UL_H	RXLEV threshold on the uplink for handover process to commence. Typical range - 103 to - 73 dBm.
L_RXQUAL_UL_H	RXQUAL threshold on the uplink for handover process to commence.
L_RXLEV_DL_H	RXLEV threshold on the downlink for handover process to commence. Typical range - 103 to - 73 dBm.
L_RXQUAL_DL_H	RXQUAL threshold on the downlink for handover process to commence.
MS_RANGE_MAX	Threshold for the maximum permitted distance between MS and current BTS. Range (2, 35 Km); step size 1.0 Km.
RXLEV_UL_IH	RXLEV threshold on uplink for intracell (interference) handover. Typical range - 85 to - 40 dBm.
RXLEV_DL_IH	RXLEV threshold on downlink for intracell (interference) handover; typical range - 85 to - 40 dBm.
RXLEV_MIN(n)	Minimum RXLEV required for an MS to be allowed to handover to cell "n".
RXLEV_MIN_DEF	Default value of RXLEV_MIN, used to evaluate handover to undefined adjacent cells.
HO_MARGIN(n)	A parameter used in order to prevent repetitive handover between adjacent cells. It may be also used as a threshold in the power budget process. Range (0, 24 dB); step size 1 dB.
HO_MARGIN_DEF	Default value of HO_MARGIN, used to evaluate handover to undefined adjacent cells.
N_CELL list	List of allowable adjacent cells for handover. Range (0, 32).
MS_TXPWR_MAX	Maximum TX power a MS may use in the serving cell. Range (5, 39 dBm) for GSM and (0,36 dBm) for DCS 1 800; step size 2 dB.
MS_TXPWR_MAX(n)	Maximum TX power a MS may use in the adjacent cell "n". Range (5, 39 dBm) for GSM and (0,36 dBm) for DCS 1 800; step size 2 dB.
MS_TXPWR_MAX_DEF	Default value of MS_TXPWR_MAX, used to evaluate handover to undefined adjacent cells.
BS_TXPWR_MAX	Maximum TX power used by the BTS.
O.X5	Boundary limits of five interference bands for the unallocated time slots. Typical range -115 to -85 dBm. (See 3GPP TS 08.08).
Hreqave	RXLEV, RXQUAL and MS_BTS Distance averaging periods defined in terms of number of SACCH multiframes. Range (1, 31); step size 1.
Hreqt	The number of averaged results that can be sent in a "handover required message" from BSS to MSC. Range (1, 31); step size 1.
Intave	Interference averaging period defined in terms of the number of SACCH multiframes. Range (1, 31); step size 1.
N1..N8,P1..P8	The number of samples used in the threshold comparison processes. Range (1, 31); step size 1.
P_Con_INTERVAL	Minimum interval between changes in the RF power level. Range (0, 30 s) step size 0.96 s.
T_Hand_RQD	Minimum interval between handover required messages related to the same connection. Range (0, 30 s); step size 0.96 s.
Pow_Incr_Step_Size	Range 2, 4 or 6 dB.
Pow_Red_Step_Size	Range 2 or 4 dB.
Number of Ranges (NR)	Number of ranges in BA_RANGE indicating the number of ranges of ARFCNs containing BCCH carriers for use as stored BCCH information.
RANGEi_LOWER	Lowest ARFCN in the ith range of carriers containing BCCH carriers for use as stored BCCH information.
RANGEi_HIGHER	Highest ARFCN in the ith range of carriers containing BCCH carriers for use as stored BCCH information.

All thresholds shall be able to take any value within the range of the parameter to which they apply. Typical operating ranges are given for some thresholds.

Annex B (informative): Power Control Procedures

Power control is important for spectrum efficiency as well as for power consumption in a cellular system. For good spectrum efficiency quality based power control is required. Power control for a packet oriented connection is more complicated than for a circuit switched connection, since there is no continuous two-way connection.

The power control formula for the MS is specified in subclause 10.2.1 (formula 1):

$$P = \Gamma_0 - \Gamma_{CH} - \alpha (C + 48) \quad (\text{all power calculations in dB})$$

This is a flexible tool that can be used for different power control algorithms. (Note that the constants Γ_0 and 48 are included only for optimising the coding of Γ_{CH}). For the BTS, there is no need to specify any algorithm, but a similar formula can be used. The following are examples of possible algorithms for uplink power control:

- Open loop control.
With this method the output power is based on the received signal level assuming the same path loss in uplink and downlink. This is useful in the beginning of a packet transmission.
- Closed loop control.
With this method the output power is commanded by the network based on received signal level measurements made in the BTS in a similar way as for a circuit switched connection.
- Quality based control.
This method can be used in combination with any of the two methods above.

B.1 Open loop control

A pure open loop is achieved by setting $\alpha = 1$ and keeping Γ_{CH} constant. The output power will then be:

$$P = \Gamma_0 - \Gamma_{CH} - C - 48$$

The value Γ_{CH} can be calculated as follows to give a target value for the received signal, SS_b , at the BTS.

The received signal level at the MS:

$$SS_m = P_{BTS} - P_b - L$$

where P_{BTS} = BTS maximum output power
 P_b = BTS power reduction due to power control
 L = path loss

The C value (normalised received signal level):

$$C = SS_m + P_b = P_{BTS} - L$$

The MS output power: $P = \Gamma_0 - \Gamma_{CH} - C - 48 = \Gamma_0 - \Gamma_{CH} - P_{BTS} + L - 48$

The received signal level at the BTS:

$$SS_b = P - L = \Gamma_0 - \Gamma_{CH} - P_{BTS} - 48$$

The constant value of Γ_{CH} :

$$\Gamma_{CH} = \Gamma_0 - P_{BTS} - SS_b - 48$$

B.2 Closed loop control

A pure closed loop is achieved by setting $\alpha = 0$. The output power will then be:

$$P = \Gamma_0 - \Gamma_{CH}$$

In this case, Γ_{CH} is the actual power level (relative to Γ_0) commanded by network. It can be based on the received signal level measured at the BTS. Power control commands can be sent when required in order to achieve the target received signal level.

B.3 Quality based control.

In order to achieve the best performance the power control should be quality based. The algorithm must also consider the path loss for stability. The algorithm is not specified, it is the responsibility of the manufacturer and/or the operator.

An example of a quality based power control algorithm is:

$$P_{n+1} = P_{\max} - \alpha ((C/I_n - C/I_{\min}) - (P_n - P_{\max})) = P_{\text{ref}} - \alpha (C/I_n - P_n)$$

where P is the output power from the MS.
 C/I is the received carrier to interference value at the BTS.
 P_{\max} , C/I_{\min} and P_{ref} are reference values.
 α is a weighting factor.
 n is the iteration index.

In the closed loop case, this formula determines Γ_{CH} :

$$\Gamma_{CH} = \Gamma_0 - P_{n+1}.$$

For the open loop case, we rewrite the formula. The carrier to interference can be written:

$$C/I = C_{BTS} - I_{BTS} = P - L - I_{BTS}$$

where C_{BTS} is the received signal level at the BTS.
 I_{BTS} is the received interference level at the BTS.

$$\text{thus } P_{n+1} = P_{\text{ref}} - \alpha (P_n - L_n - I_{BTS,n} - P_n) = P_{\text{ref}} + \alpha (L_n + I_{BTS,n})$$

As shown above, the path loss is:

$$L = P_{BTS} - C$$

The formula can therefore be written as (dropping the iteration index):

$$P = P_{\text{ref}} + \alpha (P_{BTS} - C + I_{BTS}) = \Gamma_0 - \Gamma_{CH} - \alpha (C - 48)$$

Thus, for the open loop case:

$$\Gamma_{CH} = \Gamma_0 - P_{\text{ref}} - \alpha (P_{BTS} + I_{BTS} - 48)$$

The interference level I_{BTS} is measured in the BTS. The parameter Γ_{CH} is estimated based on these measurements, considering the appropriate weighting factor α , and the known parameters P_{ref} and P_{BTS} . The Γ_{CH} values are transferred to the MS in the Power Control Parameters (see 3GPP TS 04.60).

B.4 BTS power control

The same algorithm as above can be used for downlink power control. The formula for quality based control in the MS

$$P_{n+1} = P_{\text{ref}} + \alpha (L_n + I_{BTS,n})$$

can be written for the BTS as:

$$P_{d,n+1} = P_{\text{ref}} + \alpha (L_n + \gamma_{CH,n})$$

where P_d is the BTS output power (equal to $P_{BTS} - P_b$).
 γ_{CH} is the received interference level at the MS.

Substituting the path loss and dropping the iteration index gives:

$$P_d = P_{\text{ref}} + \alpha (P_{BTS} - C + \gamma_{CH})$$

The received signal C and interference γ_{CH} is measured in the MS and transferred to the BTS, which can calculate the output power.

B.5 Example

Figure B.1 illustrates an example of the uplink power control function.

In packet idle mode, the MS measures the C value on each monitored PPCH block. Meanwhile, the BSS measures the interference of the candidate PDCHs in order to have Γ_{CH} values ready for the first transfer period. This is transferred to the MS in the Packet Uplink Assignment.

In packet transfer mode, the MS measures the C value on the BCCH carrier and updates its output power. The BSS updates the MS specific Γ_{CH} values and transfer them to the MS when needed, i.e. when the interference level has changed.

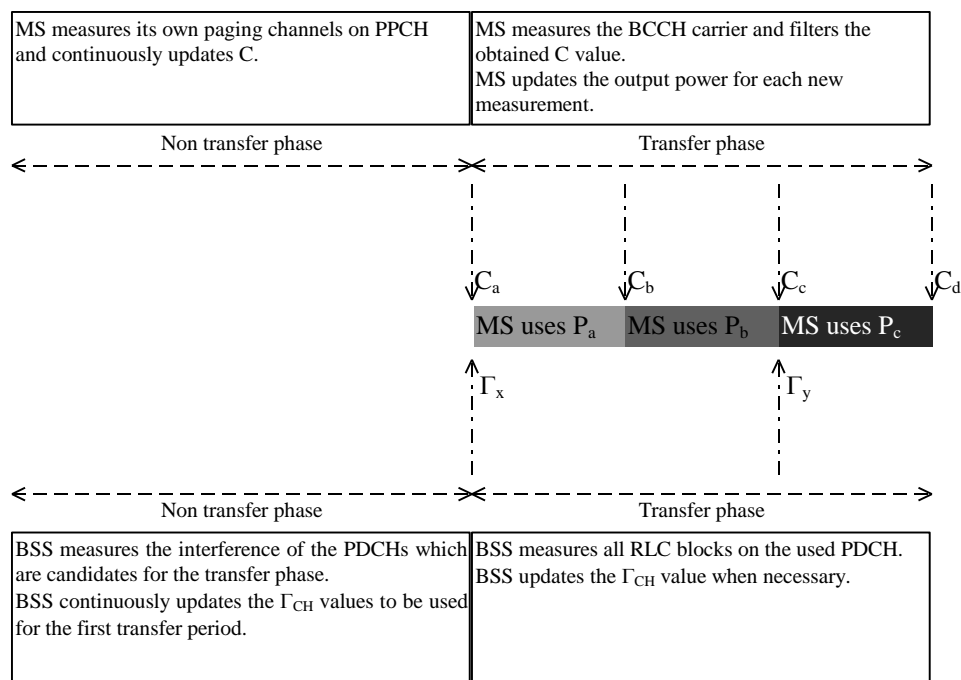

Figure B.1: Traffic example of uplink power control

Figure B.2 illustrates an example of the downlink power control function.

In packet idle mode, the MS measures the C value on each monitored PPCH block and the γ_{CH} values on some candidate PDCHs.

In packet transfer mode, the MS measures the C value on the BCCH carrier and the γ_{CH} values on all channels on the same carrier as the assigned PDCH. These values are transferred to the BTS in the Packet Downlink Ack/Nack messages. The BSS then updates the output power.

The BTS may use the maximum power for the first transfer period and set the polling for Ack/Nack as soon as possible to get the values measured in packet idle mode.

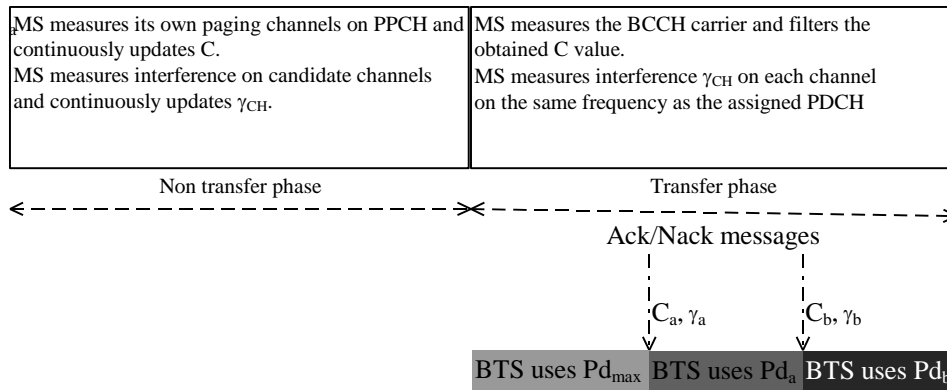

Figure B.2: Traffic example of downlink power control

B.6 Interworking between normal and fast power control for ECSD

Interworking between normal and fast power control in the ECSD mode is done so that the normal power control may be running even if fast power control is activated. This means that both the BSS and the MS shall, at all times when in dedicated ECSD mode, estimate the radio link quality plus send power level commands and link quality reports respectively based on the cycle of the reporting period of length 104 TDMA frames (as specified in subclause 8.4). When FPC is activated though, the power level commands sent via SACCH are ignored by the MS.

Through this, a switch back to normal power control can be done very easily since the MS always knows what power level to use immediately after a switch. Switching between normal and fast power control always takes place at the beginning of a reporting period.

The figure below illustrates the simultaneous operation of the two power control mechanisms and their respective functional blocks.

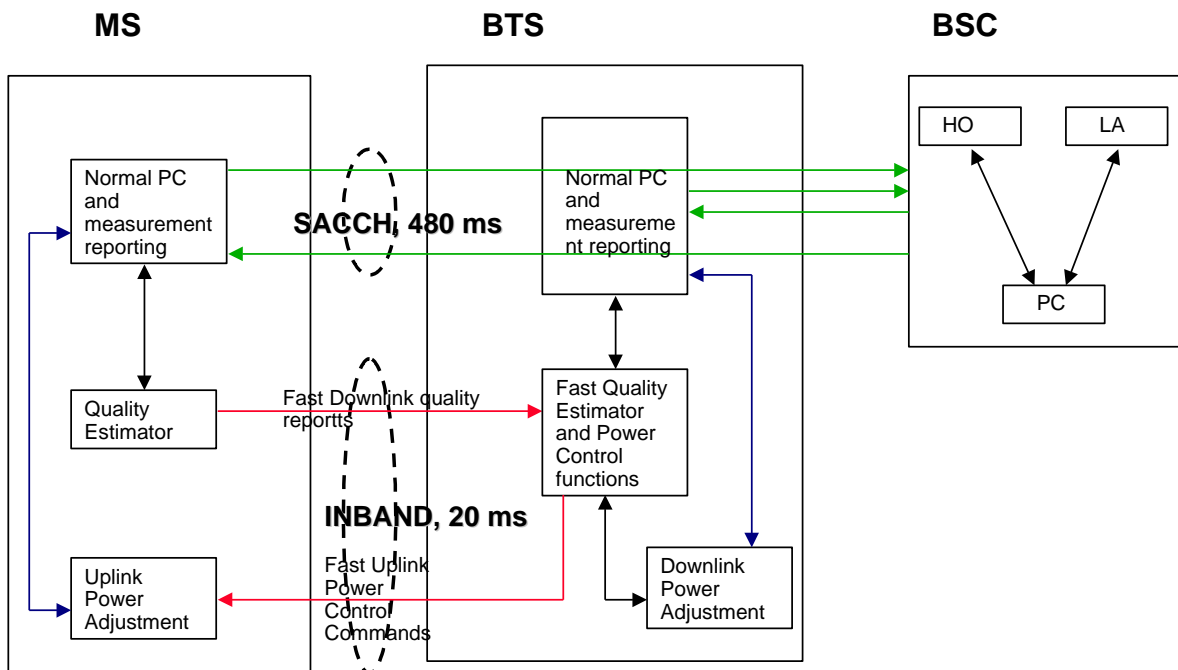

The BSC has the control over which power control loop is in use. This is signalled with one control bit on the Abis interface to the BTS, which in turn informs the MS, when the fast power control loop shall be used. When FPC is not activated, there is no requirement for either the BTS nor the MS to perform quality estimations or sending commands/reports via E-IACCH.

The specific power control algorithm to be used for fast power control is, as is the case for normal power control, implementation dependent and is thus not standardised.

Annex C (informative): Example Interference Measurement Algorithm

The following is an example algorithm for interference estimation at the MS during the Training Sequence of a normal burst (GMSK or 8PSK). The same technique may also be employed by the BTS.

The symbol spaced sampled complex envelope of the received signal $r(t)$, $\{r_n\}$, can be expressed as follows:

$$r_n = \sum_{i=-L1}^{L2} c_i u_{n-i} + z_n$$

Where $\{c_i\}$ represents the tap weights of the equivalent channel, $\{u_i\}$ represents the complex symbols of the Training Sequence, z_n represents the interference and noise contribution, and $L1$ and $L2$ are channel dispersion parameters.

STEP 1:

The channel is estimated using the first N symbols of the Training Sequence (where $N < 26$) as follows:

$$\bar{W} = \mathbf{R}^{-1} \bar{P}$$

where \bar{W} represents the estimated equivalent channel response.

$\mathbf{R} = E[\bar{u}_n \bar{u}_n^H]$ is the $K \times K$ correlation matrix of the complex symbols of Training Sequence $\{u_n\}$.

$\bar{P} = E[\bar{u}_n r_n^*]$ denotes the $K \times 1$ cross-correlation vector between the complex symbols of Training Sequence and the received signal sample $\{r_n\}$.

and $\bar{u}_n = [u_n, u_{n-1}, \dots, u_{n-K+1}]^T$.

K will be decided based on the expected maximum equivalent channel dispersion. Note that the equivalent channel corresponds to the combined channel response of the physical channel and transmit and receive filter responses. K represents the number of symbols over which the equivalent channel dispersion is spanning. $K = L1 + L2 + 1$.

STEP 2:

The interference and noise contribution (IN) is calculated for the last $M = 26 - N$ symbols of the Training Sequence as follows:

$$IN = \frac{1}{M} \sum_{k=1}^M |r_k - \bar{W}^* \bar{u}_k|^2$$

Note that the accuracy of the interference estimate will improve as M increases, on other hand the channel estimate may suffer because of a reduced N . Optionally, the symbols in the immediate vicinity on either side of the Training Sequence may also be used in estimating interference.

STEP 3:

The above procedure may be performed in both the directions scanning Training Sequence from left to right and right to left. By scanning in both the directions, IN can be obtained for the first M symbols, $IN1$, and for last M symbols, $IN2$. The interference measurement sample $SS_{CH,n}$ is calculated as follows.

$$SS_{CH,n} = (IN1 + IN2) / 2$$

Annex D (informative): Example Selection of Modulation and Coding Schemes based on Link Quality Reports

The table below gives examples of Modulation and Coding Scheme (MCS) selection based on the reported link quality estimates 8PSK_MEAN_BEP and 8PSK_CV_BEP. The selection is designed to maximise the link throughput. Further optimization e.g. for the IR mode is possible. In the same manner the MCS-1 to MCS-4 can be chosen based on GMSK_MEAN_BEP and GMSK_CV_BEP.

Table 3: 8PSK MCS selection based on BEP reports

		8PSK_CV_BEP							
		1	2	3	4	5	6	7	8
8 P S K M E A N B E P	1	MCS-5	MCS-5	MCS-5	MCS-5	MCS-5	MCS-5	MCS-5	MCS-5
	2	MCS-5	MCS-5	MCS-5	MCS-5	MCS-5	MCS-5	MCS-5	MCS-5
	3	MCS-5	MCS-5	MCS-5	MCS-5	MCS-5	MCS-5	MCS-5	MCS-5
	4	MCS-5	MCS-5	MCS-5	MCS-5	MCS-5	MCS-5	MCS-5	MCS-5
	5	MCS-5	MCS-5	MCS-5	MCS-5	MCS-5	MCS-5	MCS-5	MCS-5
	6	MCS-5	MCS-5	MCS-5	MCS-5	MCS-5	MCS-5	MCS-5	MCS-6
	7	MCS-5	MCS-5	MCS-5	MCS-5	MCS-5	MCS-5	MCS-6	MCS-6
	8	MCS-5	MCS-5	MCS-5	MCS-5	MCS-5	MCS-6	MCS-6	MCS-6
	9	MCS-5	MCS-5	MCS-5	MCS-5	MCS-6	MCS-6	MCS-6	MCS-6
	10	MCS-5	MCS-5	MCS-5	MCS-6	MCS-6	MCS-6	MCS-6	MCS-6
	11	MCS-5	MCS-5	MCS-6	MCS-6	MCS-6	MCS-6	MCS-6	MCS-7
	12	MCS-6	MCS-6	MCS-6	MCS-6	MCS-6	MCS-6	MCS-7	MCS-7
	13	MCS-6	MCS-6	MCS-6	MCS-6	MCS-6	MCS-7	MCS-7	MCS-7
	14	MCS-6	MCS-6	MCS-6	MCS-6	MCS-7	MCS-7	MCS-7	MCS-7
	15	MCS-6	MCS-6	MCS-7	MCS-7	MCS-7	MCS-7	MCS-7	MCS-7
	16	MCS-7	MCS-7	MCS-7	MCS-7	MCS-7	MCS-7	MCS-7	MCS-7
	17	MCS-7	MCS-7	MCS-7	MCS-7	MCS-7	MCS-7	MCS-7	MCS-7
	18	MCS-7	MCS-7	MCS-7	MCS-7	MCS-7	MCS-7	MCS-7	MCS-7
	19	MCS-7	MCS-7	MCS-7	MCS-7	MCS-7	MCS-7	MCS-7	MCS-7
	20	MCS-7	MCS-7	MCS-7	MCS-7	MCS-7	MCS-7	MCS-7	MCS-7
	21	MCS-7	MCS-7	MCS-7	MCS-7	MCS-7	MCS-7	MCS-7	MCS-7
	22	MCS-7	MCS-7	MCS-8	MCS-8	MCS-8	MCS-8	MCS-8	MCS-8
	23	MCS-8	MCS-8	MCS-8	MCS-8	MCS-8	MCS-8	MCS-8	MCS-8
	24	MCS-8	MCS-8	MCS-8	MCS-8	MCS-8	MCS-8	MCS-8	MCS-8
	25	MCS-8	MCS-8	MCS-8	MCS-8	MCS-8	MCS-8	MCS-8	MCS-8
	26	MCS-8	MCS-8	MCS-8	MCS-8	MCS-8	MCS-8	MCS-8	MCS-8
	27	MCS-8	MCS-8	MCS-8	MCS-8	MCS-8	MCS-8	MCS-8	MCS-8
	28	MCS-8	MCS-8	MCS-8	MCS-8	MCS-8	MCS-8	MCS-8	MCS-8
	29	MCS-9	MCS-9	MCS-9	MCS-9	MCS-9	MCS-9	MCS-9	MCS-9
	30	MCS-9	MCS-9	MCS-9	MCS-9	MCS-9	MCS-9	MCS-9	MCS-9
	31	MCS-9	MCS-9	MCS-9	MCS-9	MCS-9	MCS-9	MCS-9	MCS-9
	32	MCS-9	MCS-9	MCS-9	MCS-9	MCS-9	MCS-9	MCS-9	MCS-9

Annex E (informative): Change history

SPEC	SMG#	CR	Rev	PHS	VERS	NEW_V	SUBJECT
05.08	s24	A043		R97	5.5.0	6.0.0	Channel Quality Report in GPRS
05.08	s25	A046		R97	6.0.0	6.1.0	Improvements to GPRS power control
05.08	s25	A047		R97	6.0.0	6.1.0	Cell re-selection in GPRS
05.08	s25	A050		R97	6.0.0	6.1.0	Cell re-selection in GPRS
05.08	s25	A051		R97	6.0.0	6.1.0	GPRS Cell Re-selection
05.08	s25	A053		R97	6.0.0	6.1.0	Interference measurements for GPRS
05.08	s25	A054		R97	6.0.0	6.1.0	Renaming of GPRS RR states
05.08	s25	A055		R97	6.0.0	6.1.0	Transmission on downlink PDCH
05.08	s25	A056		R97	6.0.0	6.1.0	RF power level control during configuration change procedure
05.08					6.1.0	6.1.1	Correction of version number
05.08	s26	A057		R97	6.1.0	6.2.0	Corrections and clarifications to GPRS
05.08	s26	A058		R97	6.1.0	6.2.0	Cell re-selection in GPRS
05.08	s26	A059		R97	6.1.0	6.2.0	Mapping of PACCH
05.08	s26	A060		R97	6.1.0	6.2.0	Coding of parameter GCH
05.08	s26	A061		R97	6.1.0	6.2.0	RXQUAL measurement
05.08	s26	A063		R97	6.1.0	6.2.0	Clarification of non-DRX mode
05.08	s26	A064		R97	6.1.0	6.2.0	Release of dedicated channels
05.08	s26	A065		R97	6.1.0	6.2.0	Renaming of broadcast parameters
05.08	s26	A066		R97	6.1.0	6.2.0	Measurement reporting and network controlled cell selection
05.08	s27	A044		R97	6.2.0	6.3.0	MS delay time in reporting a new strongest neighbouring cell
05.08	s27	A068		R97	6.2.0	6.3.0	Clarification of Power Control
05.08	s27	A069		R97	6.2.0	6.3.0	Measurement reporting
05.08	s27	A072		R97	6.2.0	6.3.0	GPRS idle mode measurements
05.08	s27	A074		R97	6.2.0	6.3.0	Clarification of Complete BA (SACCH)
05.08	s27	A075		R97	6.2.0	6.3.0	Tolerances for power control
05.08	s27	A076		R97	6.2.0	6.3.0	GPRS downlink power control
05.08	s28	A080		R97	6.3.0	6.4.0	MS delay time in reporting a new strongest neighbouring cell in GPRS
05.08	s28	A081		R97	6.3.0	6.4.0	Cell re-selection
05.08	s28	A082		R97	6.3.0	6.4.0	Interference measurements on Network command
05.08	s28	A086		R97	6.3.0	6.4.0	Clarification of received signal level
05.08	s28	A087		R97	6.3.0	6.4.0	Interference measurements with frequency hopping
05.08	s28	A088		R97	6.3.0	6.4.0	Clarification of interference measurements
05.08	s28	A089		R97	6.3.0	6.4.0	Call reestablishment procedure for abnormal release with cell reselection in ready state
05.08	s28	A093		R97	6.3.0	6.4.0	Application time of Gamma and Alpha parameters for the computation on MS output power
05.08	s28	A094		R97	6.3.0	6.4.0	Clarification on MAFA measurement requirements
05.08	s28	A096		R97	6.3.0	6.4.0	Cell reselection delay time in packet transfer mode
05.08	s28	A097		R97	6.3.0	6.4.0	Clarification to a requirement to perform the interference measurements
05.08	s28	A098		R97	6.3.0	6.4.0	Neighbour measurements
05.08	s28	A099		R97	6.3.0	6.4.0	End of measurement period for the quality measurements
05.08	s28	A102		R97	6.3.0	6.4.0	Correction to I_LEVEL reporting
05.08	s28	A079		R98	6.4.0	7.0.0	Harmonization between GSM and PCS 1 900 standard
05.08	s28	A084		R98	6.4.0	7.0.0	Introduction of CTS in 05.08
05.08	s28	A100		R98	6.4.0	7.0.0	AMR DTX aspects in signal quality measurements
05.08	s29	A070		R98	7.0.0	7.1.0	Addition of SoLSA functionality
05.08	s29	A104		R98	7.0.0	7.1.0	Clarification of CTS-MS initial synchronization
05.08	s29	A105		R98	7.0.0	7.1.0	Performance of CTS power control algorithm
05.08	s29	A106		R98	7.0.0	7.1.0	Introduction of quality criteria in CTS idle mode
05.08	s29	A107		R98	7.0.0	7.1.0	Clarification of C2_CTS computation
05.08	s29	A108		R98	7.0.0	7.1.0	Clarification of range delay measurements
05.08	s29	A116		R98	7.0.0	7.1.0	Time to be ready to access a new cell
05.08	s29	A123		R98	7.0.0	7.1.0	Clarification of time of application of new alpha and gamma value in case of time slot reconfiguration
05.08	s29	A127		R98	7.0.0	7.1.0	Relation between NC_REPORTING_PERIOD and DRX period

SPEC	SMG#	CR	Rev	PHS	VERS	NEW_V	SUBJECT
05.08	s29	A131		R98	7.0.0	7.1.0	Interference measurement on packet idle mode
05.08	s29	A132		R98	7.0.0	7.1.0	Clarification of the interference measurements requirements in packet idle mode
05.08	s29	A133		R98	7.0.0	7.1.0	Cell selection parameters in Packet Measurement Order
05.08	s29	A134		R98	7.0.0	7.1.0	Calculation of SIGN_VAR
05.08	s29	A135		R98	7.0.0	7.1.0	Updating of PBCCH information
05.08	s29	A137		R98	7.0.0	7.1.0	Downlink Power Control for GPRS
05.08	s29	A141		R98	7.0.0	7.1.0	Periodic search for SoLSA cell in idle mode
05.08	s29	A145		R98	7.0.0	7.1.0	PC_MEAS_CHAN in case of downlink power control
05.08	s29	A146		R98	7.0.0	7.1.0	RXQUAL in CS4
05.08	s29	A150		R98	7.0.0	7.1.0	Corrections to cell selection for GPRS
05.08	s29	A151		R98	7.0.0	7.1.0	Clarifications to network controlled cell re-selection
05.08	s29	A153		R98	7.0.0	7.1.0	Clarification to network controlled cell re-selection
05.08	s29	A085		R99	7.1.0	8.0.0	EDGE on the BCCH carrier
05.08	s29	A144		R99	7.1.0	8.0.0	GSM 400 bands introduced in 05.08
05.08	s30	A158		R99	8.0.0	8.1.0	Clarification of idle mode support for SoLSA
05.08	s30	A162		R99	8.0.0	8.1.0	Cell re-selection when PBCCH does not exist
05.08	s30	A165		R99	8.0.0	8.1.0	Correction of C filtering
05.08	s30	A168		R99	8.0.0	8.1.0	Clarification of extended measurements
05.08	s30	A170		R99	8.0.0	8.1.0	Multiband cell selection and reporting
05.08	s30	A173		R99	8.0.0	8.1.0	Cell selection parameters in NC_FREQUENCY_LIST
05.08	s30	A176		R99	8.0.0	8.1.0	Power control measurements
05.08	s30	A179		R99	8.0.0	8.1.0	Clarification of RXQUAL for CS4
05.08	s30	A185		R99	8.0.0	8.1.0	Clarification to interference measurements in packet mode changes
05.08	s30	A188		R99	8.0.0	8.1.0	Correction of fixed allocation mode reference that should be "half duplex mode"
05.08	s30	A193		R99	8.0.0	8.1.0	Downlink Power Control for GPRS
05.08	s30b	A147		R99	8.1.0	8.2.0	Fast Power Control for ECSD
05.08	s30b	A180		R99	8.1.0	8.2.0	COMPACT Cell Selection and Reselection
05.08	s30b	A181		R99	8.1.0	8.2.0	Link Quality Control measurements for EGPRS
05.08	s30b	A199		R99	8.1.0	8.2.0	Interference measurements - Alignment 05.08 to 04.60
05.08	s30b	A202		R99	8.1.0	8.2.0	Clarification of channel quality reporting period
05.08	s30b	A206		R99	8.1.0	8.2.0	Downlink Power Control
05.08	s30b	A222		R99	8.1.0	8.2.0	Clarification of timeslots on which to make interference measurements
05.08	s30b	A228		R99	8.1.0	8.2.0	Interference measurements in packet idle mode
05.08	MCC			R99	8.2.0	8.2.1	Figures B1 and also B2 have been updated according to the agreed CR A057. The changes have been missed due to the lack of revision marks.
05.08	s31	A203		R99	8.2.1	8.3.0	COMPACT interference measurements
05.08	s31	A207		R99	8.2.1	8.3.0	Enhanced Measurement Reporting
05.08	s31	A231		R99	8.2.1	8.3.0	Clarification of Extended Measurement requirements
05.08	s31	A232		R99	8.2.1	8.3.0	Correction of measurement filtering for power control
05.08	s31	A233		R99	8.2.1	8.3.0	Enhanced Measurement Reporting for (E)GPRS
05.08	s31	A234		R99	8.2.1	8.3.0	COMPACT RF power control
05.08	s31	A240		R99	8.2.1	8.3.0	EGPRS Link Quality Control measurements
05.08	s31	A243		R99	8.2.1	8.3.0	Missing GSM 850 requirements for Classic BCCH
05.08	s31	A244		R99	8.2.1	8.3.0	Introduction of Example of EGPRS Link Adaptation Algorithm
05.08	s31b	A242		R99	8.3.1	8.4.0	Inter System Handover and Cell re-selection
05.08	s31b	A248		R99	8.3.1	8.4.0	Removal of parameter CELL_RESELECT_PARAM_IND
05.08	s31b	A270		R99	8.3.1	8.4.0	Procedures for inter-system handover (cdma2000)
05.08	s31b	A252		R99	8.3.1	8.4.0	Correction to mapping of interference levels
05.08	s31b	A253		R99	8.3.1	8.4.0	Clarification on Abnormal Cell Reselection
05.08	s31b	A269		R99	8.3.1	8.4.0	System Information refreshing in idle mode
05.08	s31b	A271		R99	8.3.1	8.4.0	MS behaviour under network controlled cell reselection
05.08	s31b	A272		R99	8.3.1	8.4.0	Cell selection parameter acquisition in Packet Transfer mode
05.08	s31b	A273		R99	8.3.1	8.4.0	BTS Output Power
05.08	s31b	A274		R99	8.3.1	8.4.0	Default value for GPRS_MS_TXPWR_MAX_CCH at cell re-selection
05.08	s31b	A249		R99	8.3.1	8.4.0	Clarification of Cell Bar Qualify 2 parameter
05.08	s31b	A266		R99	8.3.1	8.4.0	Fast inband signalling: E-IACCH
05.08	s31b	A268		R99	8.3.1	8.4.0	EGPRS Link Quality measurements
05.08	s32	A275		R99	8.4.0	8.5.0	COMPACT interference measurements
05.08	s32	A276		R99	8.4.0	8.5.0	Class A Dual Transfer Mode (DTM)

SPEC	SMG#	CR	Rev	PHS	VERS	NEW_V	SUBJECT
05.08	s32	A278		R99	8.4.0	8.5.0	Corrections to Inter system Handover and Cell re-selection
05.08	s32	A279		R99	8.4.0	8.5.0	Definition of the SCALE parameter for RXLEV reporting
05.08	s32	A280		R99	8.4.0	8.5.0	Clarification GPRS downlink transmission requirements
05.08	s32	A281		R99	8.4.0	8.5.0	Correction of inconsistency in the handling of BEP_PERIOD2
05.08	s32	A282		R99	8.4.0	8.5.0	Cell_Bar_Access_2 missing in 05.08
05.08	s32	A283		R99	8.4.0	8.5.0	Clarifications on EGPRS measurements

Change history							
Date	TSG GERAN#	TSG Doc.	CR	Rev	Subject/Comment	Old	New
2000-09	01	GP-000335	A287	1	Extended measurement report (MAFA)	8.5.0	8.6.0
2000-09	01	GP-000361	A288	1	Clarifications on EGPRS Quality parameters	8.5.0	8.6.0
2000-09	01	GP-000336	A289	1	Editorial corrections	8.5.0	8.6.0
2000-09	01	GP-000362	A290	1	Clarifications of interference measurements for COMPACT	8.5.0	8.6.0
2000-09	01	GP-000330	A291	1	Corrections to Inter System Handover and Cell re-selection	8.5.0	8.6.0
2000-09	01	GP-000325	A296	1	BTS RF power control	8.5.0	8.6.0
2000-09	01	GP-000328	A297		Correction to measurement reporting for DTM	8.5.0	8.6.0
2000-09	01	GP-000364	A298	1	Corrections to BSIC decoding	8.5.0	8.6.0
2000-11	02	GP-000843	A299	1	EGPRS Channel Quality Report reporting period	8.6.0	8.7.0
2000-11	02	GP-000577	A300		GPRS neighbour cell measurement exceptions	8.6.0	8.7.0
2000-11	02	GP-000904	A301	2	Corrections to Handover and Cell re-selection	8.6.0	8.7.0
2000-11	02	GP-000871	A302	1	Corrections to Enhanced Measurement Reporting	8.6.0	8.7.0
2000-11	02	GP-000873	A303	1	Maximum number of neighbour cell carriers to be monitored by the MS	8.6.0	8.7.0
2000-11	02	GP-000877	A305	1	Discontinuous transmission	8.6.0	8.7.0
2000-11	02	GP-000851	A306		Measurement requirements for COMPACT MS in the case of multislot allocations	8.6.0	8.7.0
2000-11	02	GP-000882	A307	1	GPRS cell reselection with Packet Measurement Order	8.6.0	8.7.0
2000-11	02				Front page layout correction	8.7.0	8.7.1
2001-01	03	GP-010057	A308		Handling of missing gamma values	8.7.1	8.8.0
2001-01	03	GP-010097	A309		Removal of Anonymous Access	8.7.1	8.8.0
2001-01	03	GP-010105	A310		Measurements during polling response transmission	8.7.1	8.8.0
2001-01	03	GP-010126	A311		Fine tuning of GPRS cell reselection	8.7.1	8.8.0
2001-01	03	GP-010203	A312		Multi-RAT measurements	8.7.1	8.8.0
2001-01	03	GP-010376	A313	1	3G Cell re-selection with only frequency information	8.7.1	8.8.0
2001-01	03	GP-010438	A314	1	Addition of GSM Blind handover requirement	8.7.1	8.8.0
2001-04	04	GP-010797	A315	1	Blind Cell re-selection synchronisation failure	8.8.0	8.9.0
2001-04	04	GP-010577	A316		Editorial correction to measurement reporting	8.8.0	8.9.0
2001-04	04	GP-010654	A317		Clarifications on System Information Type 2 quarter decoding	8.8.0	8.9.0
2001-04	04	GP-010657	A318		Correction on NBR_RCVD_BLOCKS counting	8.8.0	8.9.0
2001-04	04	GP-010914	A321		Introduction of UTRAN blind search from the PSI3 quarter	8.8.0	8.9.0
2001-06	05	GP-011415	A322	2	Clarifications due to equivalent PLMN	8.9.0	8.10.0
2001-06	05	GP-011043	A323		Missing default values for measurement parameters	8.9.0	8.10.0
2001-06	05	GP-011046	A324		Invalid BSIC: Terminology alignment	8.9.0	8.10.0
2001-08	06	GP-011861	A330	1	Correction to Predefined Configurations	8.10.0	8.11.0
2001-08	06	GP-011864	A332	1	3G reselection: suitable cell and amount to monitor	8.10.0	8.11.0
2001-08	06	GP-011524	A335		RXQUAL_SUB and RXLEV_SUB with AMR-NB	8.10.0	8.11.0
2001-11	07	GP-012221	A336		Clarification on Packet Enhanced Measurement Reporting	8.11.0	8.12.0
2001-11	07	GP-012395	A338		Number of cells/frequencies to be monitored by a dual mode terminal	8.11.0	8.12.0
2001-11	07	GP-012759	A339	1	Correction of parameters related to enhanced and 3G measurements	8.11.0	8.12.0
2001-11	07	GP-012488	A340		Clarification on UTRAN FDD RSSI reporting	8.11.0	8.12.0
2001-11	07	GP-012497	A343		Alignment of predefined configuration handling according to RAN 2 views	8.11.0	8.12.0
2002-02	08	GP-020509	A348	1	3G-GSM clarification on RSSI, FDD valid cell and MULTIRAT_REPORTING	8.12.0	8.13.0
2002-04	09	GP-020649	A349		NBR_RCVD_BLOCKS for 14.4 non-transparent data	8.13.0	8.14.0
2002-04	09	GP-021004	A356		Clarification to priorities between GPRS interference measurements and InterRAT measurements	8.13.0	8.14.0
2002-06	10	GP-021416	A357		Correction on the applicability of reporting priority	8.14.0	8.15.0
2002-06	10	GP-021420	A358		EMR in case of signalling only mode	8.14.0	8.15.0
2002-06	10	GP-021423	A359		Correction to cell reselection time requirement (GSM to UTRAN FDD)	8.14.0	8.15.0
2002-06	10	GP-022065	A362	2	Removal of CBQ2	8.14.0	8.15.0
2002-06	10	GP-021926	A364	1	Correction: validity period of NC_FREQUENCY_LIST	8.14.0	8.15.0
2003-04	14	GP-030976	A366	1	Use of unbiased variance in the computation of CV_BEP	8.15.0	8.16.0
2003-06	15	GP-031719	A369	2	Missing Test Measurement Parameters for UTRAN TDD Cell Access	8.16.0	8.17.0

2003-08	16	GP-032225	A370	2	Modification of accuracy requirements for MEAN_BEP for EGPRS	8.17.0	8.18.0
2003-08	16	GP-031780	A371	1	Correction on DTM power control	8.17.0	8.18.0
2003-08	16	GP-031984	A372		Correction for identification of TDD cells	8.17.0	8.18.0
2003-08	16	GP-032181	A374	1	Clarification to Extended Dynamic Allocation for high multislot classes	8.17.0	8.18.0
2003-08	16	GP-032221	A375	1	Correction of insufficient range of the FDD_Qmin parameter	8.17.0	8.18.0
2003-11	17	GP-032763	A376	1	Correction of applicability of NC measurement reporting parameters in context with dedicated mode connections	8.18.0	8.19.0
2004-06	20	GP-041261	A377		Applicability of individual NC parameters	8.19.0	8.20.0
2004-06	20	GP-041692	A378		Correction of DTM Output Power Control	8.19.0	8.20.0
2004-08	21	GP-041918	A379		CPICH RSCP based criterion for GERAN to UTRAN FDD cell reselection	8.20.0	8.21.0
2004-11	22	GP-042451	A380	2	Downlink power control for DTM	8.21.0	8.22.0
2005-11	27	GP-052746	A382	1	Accuracy requirements of MS MEAN_BEP estimation	8.22.0	8.23.0