

3GPP TS 04.05 V8.0.2 (2002-05)

Technical Specification

**3rd Generation Partnership Project;
Technical Specification Group GSM EDGE Radio Access Network;
Data Link (DL) layer;
General aspects
(Release 1999)**



The present document has been developed within the 3rd Generation Partnership Project (3GPP[™]) and may be further elaborated for the purposes of 3GPP.

The present document has not been subject to any approval process by the 3GPP Organizational Partners and shall not be implemented. This Specification is provided for future development work within 3GPP only. The Organizational Partners accept no liability for any use of this Specification. Specifications and reports for implementation of the 3GPP[™] system should be obtained via the 3GPP Organizational Partners' Publications Offices.

Keywords

<keyword[, keyword]>

3GPP

Postal address

3GPP support office address

650 Route des Lucioles - Sophia Antipolis
Valbonne - FRANCE
Tel.: +33 4 92 94 42 00 Fax: +33 4 93 65 47 16

Internet

<http://www.3gpp.org>

Copyright Notification

No part may be reproduced except as authorized by written permission.
The copyright and the foregoing restriction extend to reproduction in all media.

© 2002, 3GPP Organizational Partners (ARIB, CWTS, ETSI, T1, TTA, TTC).
All rights reserved.

Contents

Foreword	4
1 Scope	5
1.1 References	5
1.2 Abbreviations	6
2 Concepts and terminology	6
3 Overview description of LAPDm functions and procedures	9
3.1 General.....	9
3.2 Unacknowledged operation.....	10
3.3 Acknowledged operation.....	10
3.4 Information transfer mode	11
3.4.1 Information transfer on the BCCH	11
3.4.2 Information transfer on the PCH + AGCH	11
3.4.3 Information transfer on the DCCHs	11
3.5 Release of data links	11
4 Service characteristics	11
4.1 General.....	11
4.2 Services provided to layer 3	11
4.2.1 General	11
4.2.2 Priority	12
4.2.3 Segmentation	12
4.2.4 Unacknowledged information transfer service	12
4.2.5 Acknowledged information transfer services	12
4.2.6 Random access procedure.....	14
4.3 Services required from the physical layer	14
4.4 Administrative services.....	15
4.4.1 General description of administrative services.....	15
4.4.2 Definition of primitives for administrative services	15
5 Overview of data link layer structure	15
5.1 Functional composition	15
5.2 Identification of data link end points	16
5.3 Data link procedure	16
5.4 Data link distribution procedure.....	16
5.5 Random access procedures.....	17
6 Specific requirements	17
6.1 Mode of operation and allowed SAPIs	17
6.2 Acknowledged mode of operation	18
6.2.1 Window size	18
6.2.2 Processing capacity	18
Annex A (informative): Change History	19

Foreword

This Technical Specification has been produced by the 3rd Generation Partnership Project (3GPP).

The contents of the present document are subject to continuing work within the TSG and may change following formal TSG approval. Should the TSG modify the contents of the present document, it will be re-released by the TSG with an identifying change of release date and an increase in version number as follows:

Version x.y.z

where:

- x the first digit:
 - 1 presented to TSG for information;
 - 2 presented to TSG for approval;
 - 3 or greater indicates TSG approved document under change control.
- y the second digit is incremented for all changes of substance, i.e. technical enhancements, corrections, updates, etc.
- z the third digit is incremented when editorial only changes have been incorporated in the document.

1 Scope

The present document describes in general terms the Link Access Procedures on the Dm channel, LAPDm. The application of this protocol to other channel types is for further study. Details are provided in 3GPP TS 04.06.

The purpose of LAPDm is to convey information between layer 3 entities across the GSM PLMN radio interface (MS to network interface) using the Dm channel.

NOTE 1: The term Dm channel is used for convenience to designate the collection of all the various signalling channels required in the GSM system. See also 3GPP TS 04.03.

The definition of LAPDm is based on the principles and terminology of:

- CCITT Recommendations X.200 and X.210: the reference model for Open Systems Interconnection (OSI);
- CCITT Recommendations Q.920 and Q.921: the specification of LAPD for the user-network interface in ISDN;
- CCITT Recommendation X.25 LAPB: user-network interface for packet mode terminals; and
- ISO 3309 and ISO 4335: High-level Data Link Control (HDLC) standards for frame structure and elements of procedures.

LAPDm is a protocol that operates at the data link layer of the OSI architecture. The relationship between the data link layer and other protocol layers is defined below.

NOTE 2: The interface between the mobile station and external terminal equipment/terminal adapters is defined in the Technical Specifications of the 3GPP TS 07-series.

NOTE 3: The physical layer on the radio interface is defined in 3GPP TS 04.04 and layer 3 is defined in 3GPP TS 04.07, 04.08, 04.10 and 04.11. Reference should be made to these Technical Specifications for the complete definitions of the protocols and procedures across the GSM PLMN radio interface.

NOTE 4: The term "data link layer" is used in the main text of the present document. However, mainly in figures and tables, the terms "layer 2" and "L2" are used as abbreviations. Furthermore, in accordance with 3GPP TS 04.07 and 04.08 the term "layer 3" is used to indicate the layer above the data link layer.

LAPDm is independent of the transmission bit rate. It requires physical channels with characteristics as defined in 3GPP TS 04.03.

Section 2 below describes basic concepts used in the present document and 3GPP TS 04.06.

Section 3 gives an overview description of LAPDm functions and procedures.

Section 4 summarizes the services that the data link layer provides to layer 3 and the services that the data link layer requires from the physical layer.

Section 5 provides an overview of the data link layer structure.

1.1 References

The following documents contain provisions which, through reference in this text, constitute provisions of the present document.

- References are either specific (identified by date of publication, edition number, version number, etc.) or non-specific.
- For a specific reference, subsequent revisions do not apply.
- For a non-specific reference, the latest version applies. In the case of a reference to a 3GPP document (including a GSM document), a non-specific reference implicitly refers to the latest version of that document *in the same Release as the present document*.

[1] 3GPP TS 01.04: "Abbreviations and acronyms".

- [2] 3GPP TS 04.01: "Mobile Station - Base Station System (MS - BSS) interface: General aspects and principles".
- [3] 3GPP TS 04.03: "Mobile Station - Base Station System (MS - BSS) interface: Channel structures and access capabilities".
- [4] 3GPP TS 04.04: "Layer 1: General requirements".
- [5] 3GPP TS 04.06: "Mobile Station - Base Station System (MS - BSS) interface: Data Link (DL) layer specification".
- [6] 3GPP TS 04.07: "Mobile radio interface signalling layer 3; General aspects".
- [7] 3GPP TS 04.08: "Mobile radio interface layer 3: specification".
- [8] 3GPP TS 04.10: "Mobile radio interface layer 3: Supplementary services specification General aspects".
- [9] 3GPP TS 04.11: "Point-to-Point (PP) Short Message Service (SMS) support on mobile radio interface".
- [10] Void.
- [11] Void.
- [12] Void.
- [13] Void.
- [14] Void.
- [15] CCITT Recommendation X.25: "Interface between data terminal equipment (DTE) and data circuit - terminating equipment (DCE) for terminals operating in the packet mode and connected to public data networks by dedicated circuit".
- [16] CCITT Recommendation X.200: "Reference Model of Open Systems Interconnection for CCITT Applications".
- [17] CCITT Recommendation X.210: "Open Systems Interconnection layer service definition conventions".
- [18] CCITT Recommendation Q.920: "Integrated services digital network (ISDN) user-network interface - Data link layer General aspects".
- [19] CCITT Recommendation Q.921: "Integrated services digital network (ISDN) user-network interface - Data link layer specification".
- [20] ISO 3309: "Information technology - Telecommunications and information exchange between systems - High level data link control (HDLC) procedures - Frame structure".
- [21] ISO/IEC 4335: "Information technology - Telecommunications and information exchange between systems - High level data link control (HDLC) procedures - Elements of procedures".

1.2 Abbreviations

Abbreviations used in the present document are listed in 3GPP TS 01.04.

2 Concepts and terminology

The general layering principles used in the present document and other specifications in the 04 series are given in 3GPP TS 04.01.

The data link layer is the next to lowest layer of the OSI reference model. The data link layer receives services from the physical layer and provides services to layer 3.

The services provided by the data link layer are the combination of the services and functions provided by both the data link layer and the physical layer.

A data link layer Service Access Point (SAP) is the point at which the data link layer provides services to layer 3. The Service Access Point is identified by a Service Access Point Identifier (SAPI). One or more data link connection endpoints can be associated with each data link layer SAP. See figure 1. A data link connection endpoint is identified by a data link connection endpoint identifier (as seen from layer 3) and by a Data Link Connection Identifier DLCI (as seen from the data link layer).

SAPs and DLCIs used by LAPDm are defined in section 5.2.

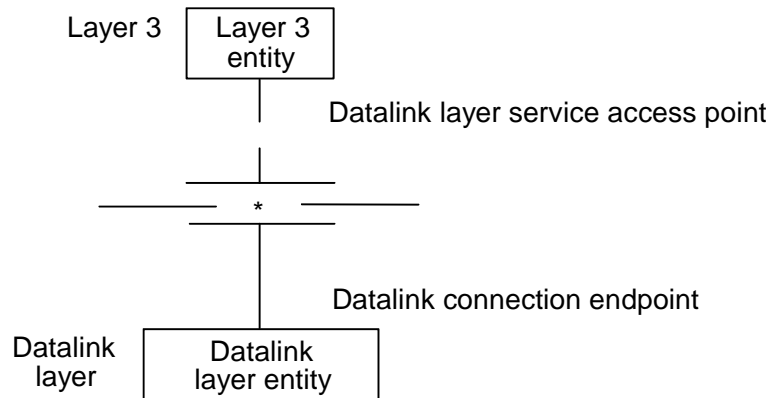

Figure 1: Entities, service access points and endpoints

Co-operation between data link layer entities is governed by a peer-to-peer protocol specific to the layer. For information exchange between two or more layer 3 entities, an association must be established between the layer 3 entities in the data link layer using a data link layer protocol. This association is called a data link connection. Data link connections are provided by the data link layer between two or more SAPs (see figure 2).

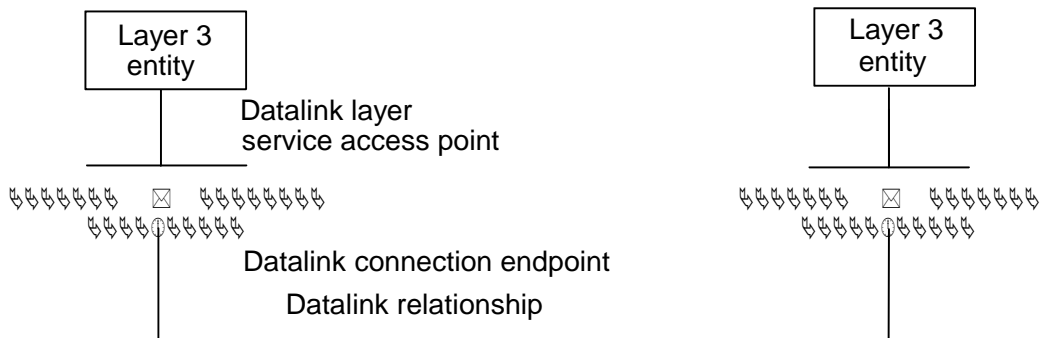
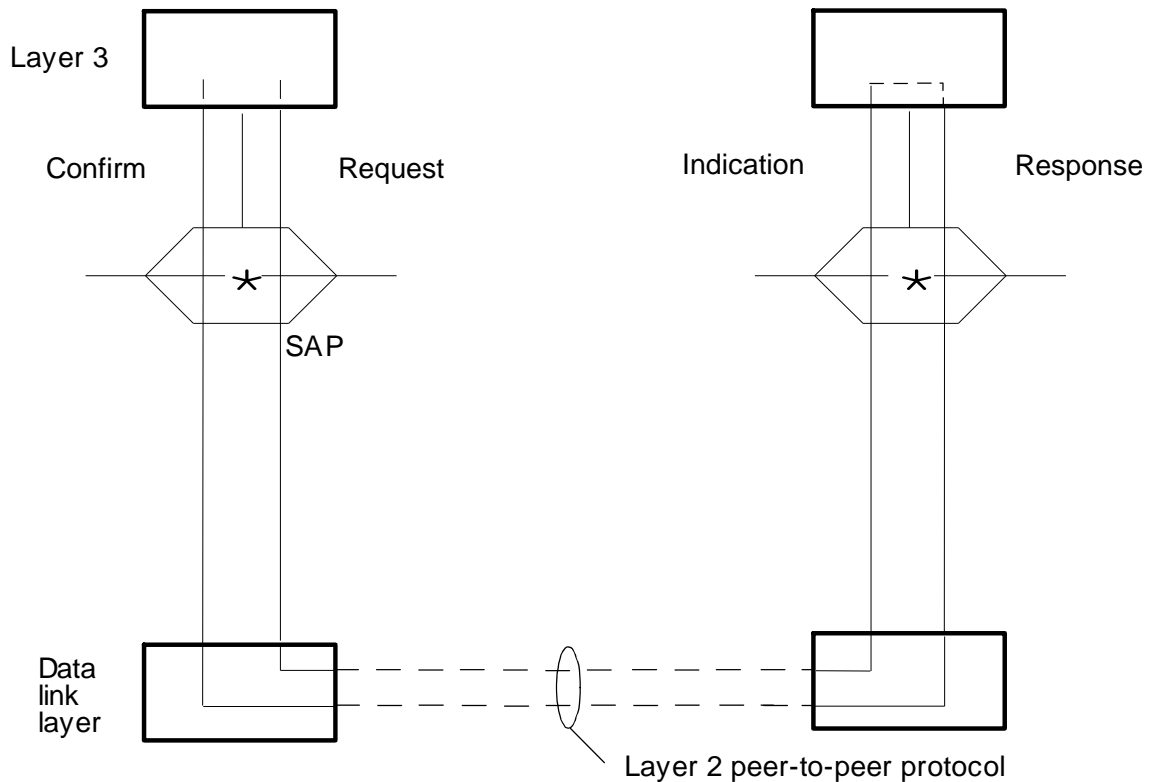

Figure 2: Peer-to-peer relationship

Data link layer message units are conveyed between data link layer entities by means of physical connection.

Layer 3 requests services from the data link layer via service primitives. The same applies for the interaction between the data link layer and the physical layer. The primitives represent, in an abstract way, the logical exchange of information and control between the data link layer and its adjacent layers. They do not specify or constrain implementations.

The primitives that are exchanged between the data link layer and adjacent layers are of the following four types (see also figure 3).



NOTE: The same principle applies for data link layer- physical layer interactions.

Figure 3: Primitive action sequence

The REQUEST primitive type is used when a higher layer is requesting a service from the next lower layer.

The INDICATION primitive type is used by a layer providing a service to notify the next higher layer of activities related to the primitive type REQUEST.

The RESPONSE primitive type is used by a layer to acknowledge receipt, from a lower layer, of the primitive type INDICATION.

The CONFIRM primitive type is used by the layer providing the requested service to confirm that the activity has been completed.

The precise specification of Layer-to-layer interactions is given in 3GPP TS 04.06.

Information between peer entities and between entities in adjacent layers attached to the same SAP is transferred in two different types of message units:

- message units of a peer-to-peer protocol; and
- message units that contain layer-to-layer information concerning status and specialized service requests.

The message units of the layer 3 peer-to-peer protocol are carried by the data link connection. The message units containing layer-to-layer information concerning status and specialized service requests are never conveyed over a data link connection or a physical connection.

The present document introduces (see also figure 4):

- a) the peer-to-peer protocol for the transfer of information and control between any pair of data link layer service access points;
- b) the interactions between the data link layer and layer 3, and between the data link layer and the physical layer.

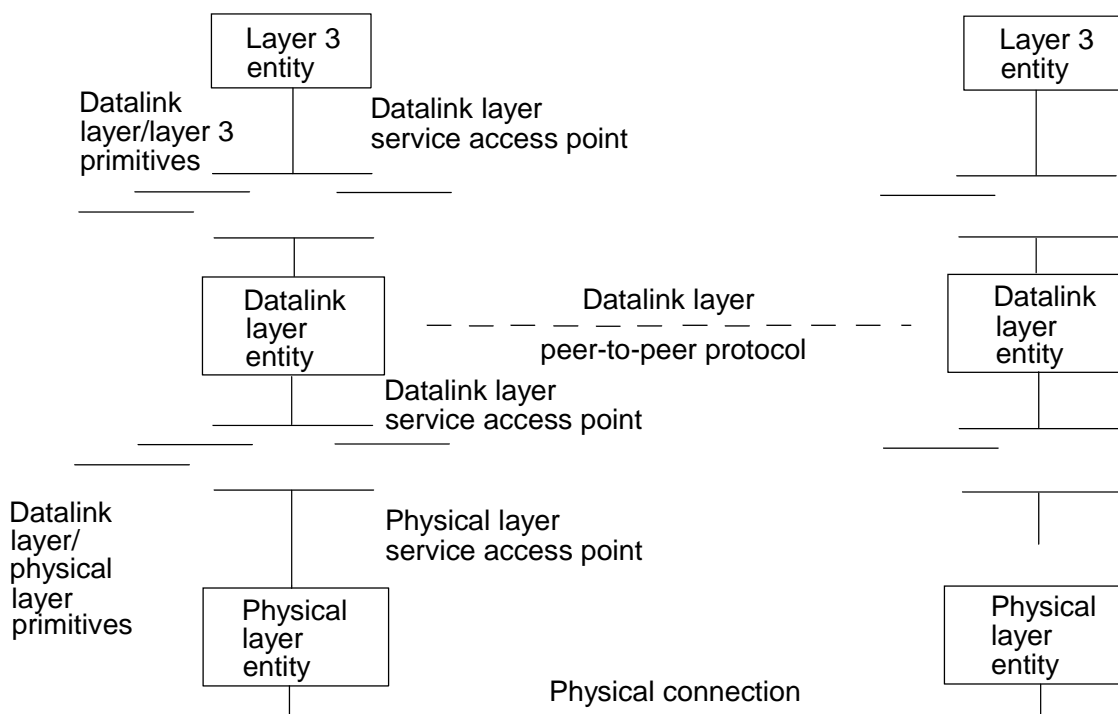

Figure 4: Data link layer reference model

3 Overview description of LAPDm functions and procedures

3.1 General

The purpose of LAPDm is to convey information between layer 3 entities across the GSM PLMN radio interface using the Dm channel. Specifically LAPDm will support:

- multiple layer 3 entities;
- multiple physical layer entities;
- broadcast control channel (BCCH) signalling;
- paging channel (PCH) signalling;
- access grant channel (AGCH) signalling;
- dedicated control channel (DCCH) signalling.

NOTE 1: The term "DCCH" designates a number of control channels (SDCCH, FACCH and SACCH) as defined in 3GPP TS 04.03.

NOTE 2: The random access channel (RACH) does not utilise LAPDm. However, for the purpose of specification, the data link layer acts as a protocol interface between layer 3 and the physical layer also for random access.

The frame structure of data link layer messages is defined in 3GPP TS 04.06.

The Dm channel between a network and a specific MS may be distorted on several control channels, e.g. PCH, SDCCH and FACCH during a connection (See also 3GPP TS 04.03). Selection and activation of these channels is performed by layer 3.

LAPDm includes functions for:

- a) the provision of one or more data link connections on a Dm channel. Discrimination between the data link connections is by means of a data link connection identifier (DLCI);
- b) allowing recognition of frame types;
- c) allowing layer 3 message units to be passed transparently between layer 3 entities;
- d) sequence control, to maintain the sequential order of frames across a data link connections;
- e) detection of format and operational errors on a data link;
- f) notification to the layer 3 entity of unrecoverable errors;

NOTE 3: It is in the responsibility of layer 3 entity to recover from these errors.

- g) flow control; and

- h) contention resolution when establishing a data link after an access request has been made on the RACH.

Two types of operation of the data link layer are defined for layer 3 information transfer: unacknowledged operation and acknowledged (multiple frame) operation. They may co-exist on a Dm channel.

The BCCH and the (PCH + AGCH) will only support unacknowledged operation. The SDCCH, SACCH and FACCH will support both types of operation.

3.2 Unacknowledged operation

In unacknowledged operation, layer 3 information is transmitted in Unnumbered Information (UI) frames.

At the data link layer, the UI frames are not acknowledged. Flow control mechanisms and error recovery mechanisms are not defined.

Applicability of unacknowledged operation to different types of control channels is specified in subclause 6.1.

3.3 Acknowledged operation

In acknowledged operation, layer 3 information is transmitted in frames that are acknowledged by the receiving data link layer.

Error recovery procedures based on retransmission of unacknowledged frames are specified. In case of errors which cannot be corrected by the data link layer, a report is issued to the layer 3 entity. Flow control procedures are also defined.

Applicability of acknowledged operation to different types of control channels is specified in subclause 6.1.

Only one form of acknowledged information transfer is defined, i.e. multiple frame operation.

For multiple frame operation, layer 3 information is sent in numbered Information (I) frames. In principle, a number of I frames may be outstanding at the same time. However, for many applications (e.g. signalling) a window size of 1 is required. Multiple frame operation is initiated by a multiple frame establishment procedure using a Set Asynchronous Balanced Mode (SABM) command.

If an access request has been made on the RACH, the establishment procedure also contains functions for resolving any ambiguity that may arise as a result of this access method.

3.4 Information transfer mode

3.4.1 Information transfer on the BCCH

The BCCH exists only in the network to MS direction and is used for broadcasting radio sub-system information to MSs. Only UI frames are sent on the BCCH.

3.4.2 Information transfer on the PCH + AGCH

These channels exist only in the network to MS direction. On the PCH + AGCH only unacknowledged operation is possible.

3.4.3 Information transfer on the DCCHs

On the DCCHs both unacknowledged operation and multiple frame operation are possible (see section 6.1). The type of operation required at any time is determined by layer 3.

3.5 Release of data links

Multiple frame operation may be released in the following ways:

- normal release by exchange of commands/responses. This type of release is initiated by layer 3;
- local end release, i.e. without exchange of commands/responses, initiated and controlled by layer 3;
- abnormal local end release, i.e. without exchange of commands/responses, commanded by layer 3.

The release mode is indicated by layer 3.

No release mechanism using exchange of commands/responses is defined for unacknowledged operation.

4 Service characteristics

4.1 General

The data link layer provides services to layer 3 and utilizes the services provided by the physical layer.

In the present document and 3GPP TS 04.06 the following general syntax is used for describing primitives.

XX - Generic Name - Type (Parameters).

where XX designates the layer providing the services. In the present document XX is DL and MDL for the data link layer and PH for the physical layer.

4.2 Services provided to layer 3

4.2.1 General

The specification of the interactions with layer 3 (primitives) provides a description of the services that the data link layer, plus the physical layer, offer to layer 3, as viewed from layer 3.

Two forms of information transfer services are associated with layer 3. The first is based on unacknowledged information transfer at the data link layer and the second service is based on acknowledged information transfer at the data link layer using multiple frame operation. Different information transfer services may co-exist on the same data link subject to restrictions imposed by the type of channel being used (see subclause 3.4).

In addition, the data link layer will pass primitives between the physical layer and layer 3 for random access operation on the RACH.

4.2.2 Priority

The priority between data links shall be as follows:

On SDCCH:

Highest priority : SAPI = 0;

Lowest priority : SAPI = 3.

On SACCH:

The priority arrangement on the SACCH must ensure that if a SAPI = 3 frame is awaiting transmission, two SAPI = 0 frames are not sent in consecutive SACCH frames. In addition, for the mobile to network direction it must also be ensured that any SAPI = 3 frame is followed by at least one SAPI = 0 frame.

4.2.3 Segmentation

For the acknowledged mode of information transfer the data link layer offers segmentation at the transmitter of layer 3 message units if the message unit is longer than the information field of the data layer frames. At the receiver the segmented layer 3 message units are concatenated such that the integrity of the layer 3 message unit is restored.

For unacknowledged operation the data link layer does not offer segmentation services.

4.2.4 Unacknowledged information transfer service

NOTE: In this case the information transfer is not acknowledged at the data link layer. Acknowledgement procedures may be provided at higher layers.

The characteristics of the unacknowledged information transfer service are summarized in the following:

- a) provision of a data link connection between layer 3 entities for unacknowledged information transfer of layer 3 message units;
- b) identification of data link connection endpoints to permit a layer 3 entity to identify another layer 3 entity;
- c) sending of frames in accordance with priority given to the message;
- d) no verification of message arrival within the data link layer.

The primitives associated with the unacknowledged information transfer service are:

DL-UNIT DATA-REQUEST/INDICATION

The DL-UNIT DATA-REQUEST primitive is used to request that a message unit be sent using the procedures for unacknowledged information transfer service; DL-UNIT DATA-INDICATION indicates the arrival of a message unit received by means of unacknowledged information transfer. Parameters associated with these primitives are the message unit, priority and the type of channel being used (BCCH, PCH + AGCH or specific type of DCCH).

4.2.5 Acknowledged information transfer services

One mode of acknowledged operation is defined, i.e. multiple frame operation.

The characteristics of this service are summarized in the following:

- a) provision of a data link connection between layer 3 entities for acknowledged information transfer of layer 3 message units;
- b) identification of data link connection endpoints to permit a layer 3 entity to identify another layer 3 entity;
- c) sequence integrity of data link layer message units in the absence of machine malfunctions;

- d) notification to the peer entity in the case of errors, for example, loss of sequence;
- e) notification to the layer 3 entity of unrecoverable errors detected by the data link layer;
- f) flow control;
- g) sending of frames in accordance with the indicated SAPI value (see also subclause 4.2.2);
- h) segmentation and concatenation control functions;
- i) suspension of the service during change of dedicated channels and resumption of service on the new channel without message loss (SAPI = 0 only); duplication of messages which may occur are treated on layer 3 (SAPI = 0 only).
- j) prioritization of messages by a layer 3 entity with preemption of low priority messages by high priority messages (SAPI = 0 only).

The following list gives an overview of the primitives associated with the multiple frame acknowledged information transfer services (for detailed specification, see 3GPP TS 04.06):

- a) Data transfer using I frames:

DL-DATA-REQUEST/INDICATION

The DL-DATA-REQUEST primitive is used to request that a message unit be sent using the procedures for multiframe acknowledged information transfer. The DL-DATA-INDICATION primitive indicates the arrival of a message unit received by means of acknowledged information transfer. The parameters associated with these primitives are the message unit, the type of channel being used and, for a DL-DATA-REQUEST primitive, the message priority.

- b) Establishment of multiple frame operation using the SABM command:

DL-ESTABLISH-REQUEST/INDICATION/CONFIRM

These primitives are used to request, indicate and confirm the establishment of multiple frame operation between two data link layer entities. Possible parameters are the message unit, the establish mode and the type of channel being used.

- c) Suspension of multiple frame operation:

DL-SUSPEND-REQUEST/CONFIRM

These primitives are used in a MS to request and confirm the suspension of multiple frame operation while changing a dedicated channel. A possible parameter is the type of channel to be affected.

- d) Resumption of multiple frame operation:

DL-RESUME-REQUEST/CONFIRM

These primitives are used in a MS to request and confirm the resumption of multiple frame operation after it has been suspended (see paragraph c) above). Possible parameters are the message unit and the type of channel to be affected.

- e) Restoration of multiple frame operation:

DL-RECONNECT-REQUEST/CONFIRM

These primitives are used in a MS to request and confirm the restoration of multiple frame operation on the old channel after failure of the channel change. Possible parameters are the message unit and the type of channel to be affected.

- f) Termination of multiple frame operation:

DL-RELEASE-REQUEST/INDICATION/CONFIRM

These primitives are used to request, indicate and confirm an attempt to terminate multiple frame operation between two data link layer entities or an attempt to perform local end release. The parameters associated with this primitive are the type of channel and the release mode.

4.2.6 Random access procedure

The primitives associated with random access are:

DL-RANDOM ACCESS-REQUEST/INDICATION/CONFIRM

The DL-RANDOM ACCESS-REQUEST primitive is used in the MS to request the transmission of a random access burst. The DL-RANDOM ACCESS-CONFIRM primitive is used to notify layer 3 that the random access burst has been sent. The DL-RANDOM ACCESS-INDICATION primitive is used in the network to indicate the arrival of a random access burst. The parameter associated with the REQUEST primitives is the random access message unit. The parameters associated with the INDICATION primitive are the random access message unit and the time slot in which the random access burst was received. The parameter associated with the CONFIRM primitive is a message unit containing the number of the time slot in which the random access burst was sent.

4.3 Services required from the physical layer

The services provided by the physical layer are described in detail in 3GPP TS 04.04. They are summarized in the following:

- a) physical layer connection for transparent transmission of frames. The bits of a frame are to be delivered to the peer data link entity in the same order in which they were submitted to the physical layer by the sender;
- b) indication of the physical status of the Dm channel;
- c) transmission of data link layer message units in the same order as they were issued by the data link layer;
- d) provision of frame synchronization;
- e) provision of error protection to ensure a low residual bit error rate at the data link layer;
- f) transmission (in the MS) and reception (in the network) of random access bursts.

The primitives between the data link layer and the physical layer are:

- a) Data transfer:

PH-DATA-REQUEST/INDICATION

These primitives are used to request that a message unit be sent and to indicate the arrival of message unit. Parameters associated with these primitives are the data link layer message unit, the priority and the type of channel being used.

- b) Random access:

PH-RANDOM ACCESS-REQUEST/INDICATION/CONFIRM

The REQUEST primitive is used to request (in the MS) that a random access frame be sent and the INDICATION primitive is used to indicate (in the network) the arrival of a random access frame. A parameter associated with these primitives is the random access message unit. The CONFIRM primitive is used (in the MS) to confirm in which time slot the random access burst was sent.

- c) Connection establishment:

PH-CONNECT-INDICATION

This primitive is used to indicate that a specific physical resource has been established on the physical layer. The parameter associated with this primitive is the type of channel.

NOTE: Activation of a physical resource is usually initiated by the layer 3 entity without involving data link layer entities.

- d) Transmission synchronization:

PH-READY-TO-SEND-INDICATION

This primitive is used to enable the data link layer to synchronize to the next instant of physical transmission. The parameter associated with this primitive is the type of channel.

PH-EMPTY-FRAME-REQUEST

This primitive is used by the data link layer instead of the PH-DATA-REQUEST primitive when no frame has to be sent after receiving the PH-READY-TO-SEND indication. The parameter associated with this primitive is the type of channel.

4.4 Administrative services

4.4.1 General description of administrative services

The data link layer entity supports several internal functions of the MS or the network not requiring layer 3 peer-to-peer information transfer. The functions provided by the data link layer are:

- error reporting between the data link layer and the layer 3 entity;
- abnormal release of the data link layer in case of protocol or other failures from which the data link layer cannot recover on its own.

The administrative functions and the interactions between the data link layer and the layer 3 entities are described in terms of service primitives.

4.4.2 Definition of primitives for administrative services

The primitives between the layer 3 entity and the data link layer for supporting administrative services are:

- a) Error handling:

MDL-ERROR-INDICATION

This primitive is used by the data link layer to indicate that there is an error in the data link layer procedures that cannot be resolved by normal exception handling procedures. Parameters associated with this primitive are the reason for error reporting and the type of channel.

- b) Release:

MDL-RELEASE-REQUEST

This primitive is used by the layer 3 entity to initiate abnormal local end release of a data link. Parameters associated with this primitive are indications of which data links are to be released and the reason for abnormal release.

5 Overview of data link layer structure

5.1 Functional composition

Figure 5 is an example of a functional block diagram of the data link layer in the MS. In the example the data link connection for all physical channels terminates at the SAP identified by SAPI = 0 but only the data link connection for a SACCH terminates at the SAP identified by SAPI = 3. Other arrangements are possible depending on the capabilities of the MS.

The network will contain a similar arrangement with one (PCH + AGCH), SDCCH, SACCH, as required, for each active MS.

Figure 5 illustrates three procedural types: the data link procedure, the data link distribution procedure and the random access procedure.

5.2 Identification of data link end points

The data link endpoints are identified by a Data Link Connection Identifier (DLCI).

The DLCI consists of two elements:

- the Service Access Point Identifier (SAPI) which is carried in the address field of each frame;
- the type of control channel on which the data link connection is or is to be established. This information is not carried in frames between data link layer peer entities but is managed locally in each end system and is carried in primitives between the layers.

When a layer 3 message unit is to be sent, layer 3 will select the appropriate SAP and data link connection end point. Layer 3 will indicate to the data link layer which data link connection end point has been chosen.

When receiving a frame containing a layer 3 message unit, the data link layer will receive from the physical layer an indication concerning the type of channel on which the frame was received. This information together with the SAPI contained in the frame enables the data link layer to deliver the layer 3 message unit to the required data link connection end point of the indicated SAP.

The SAP takes a specific value for each of the following functions carried on the Dm channel:

- call control signalling, mobility management signalling, supplementary services signalling and radio resource management signalling information as defined in 3GPP TS 04.08 and 04.10: SAPI = 0;
- short message services as defined in 3GPP TS 04.11: SAPI = 3.

Other functions requiring specific SAPI values may be defined in the future.

5.3 Data link procedure

There is at most one instance of the data link layer procedure for each SAPI on each type of channel supported on that SAPI.

For some combinations of SAPI and type of channel only a subset (e.g. unacknowledged operation) of the overall data link layer procedure is required.

The procedure analyses the control field and the length indicator field of the received frame (see 3GPP TS 04.06) and provides appropriate peer-to-peer responses and layer-to-layer indications. In addition, it analyses the data link layer service primitives and transmits the appropriate peer-to-peer commands and responses.

The procedure also performs segmentation and concatenation of layer 3 message units.

5.4 Data link distribution procedure

This procedure is only required if there are more than one SAPI supported on a channel associated with a specific MS.

The procedure analyses the address field of a received frame and the type of physical channel contained in the primitive received from the physical layer. It then distributes the frames to the appropriate data link procedure block.

On frame transmission, the procedure delivers the frames to the required channel after layer 3 has established the respective association between the channel and its physical parameters. The procedure also provides for resolution of conflicts between the various data link procedure blocks on the same physical channel. The conflict resolution is based on the SAPI and the priority requested by layer 3 (see also note to subclause 4.2.2).

5.5 Random access procedures

This procedure is used for data links on the random access channel (RACH). The procedure in the MS formats the random access frames and initiates transmission of them. The procedure in the network receives the random access frames and provides the appropriate indication to layer 3.

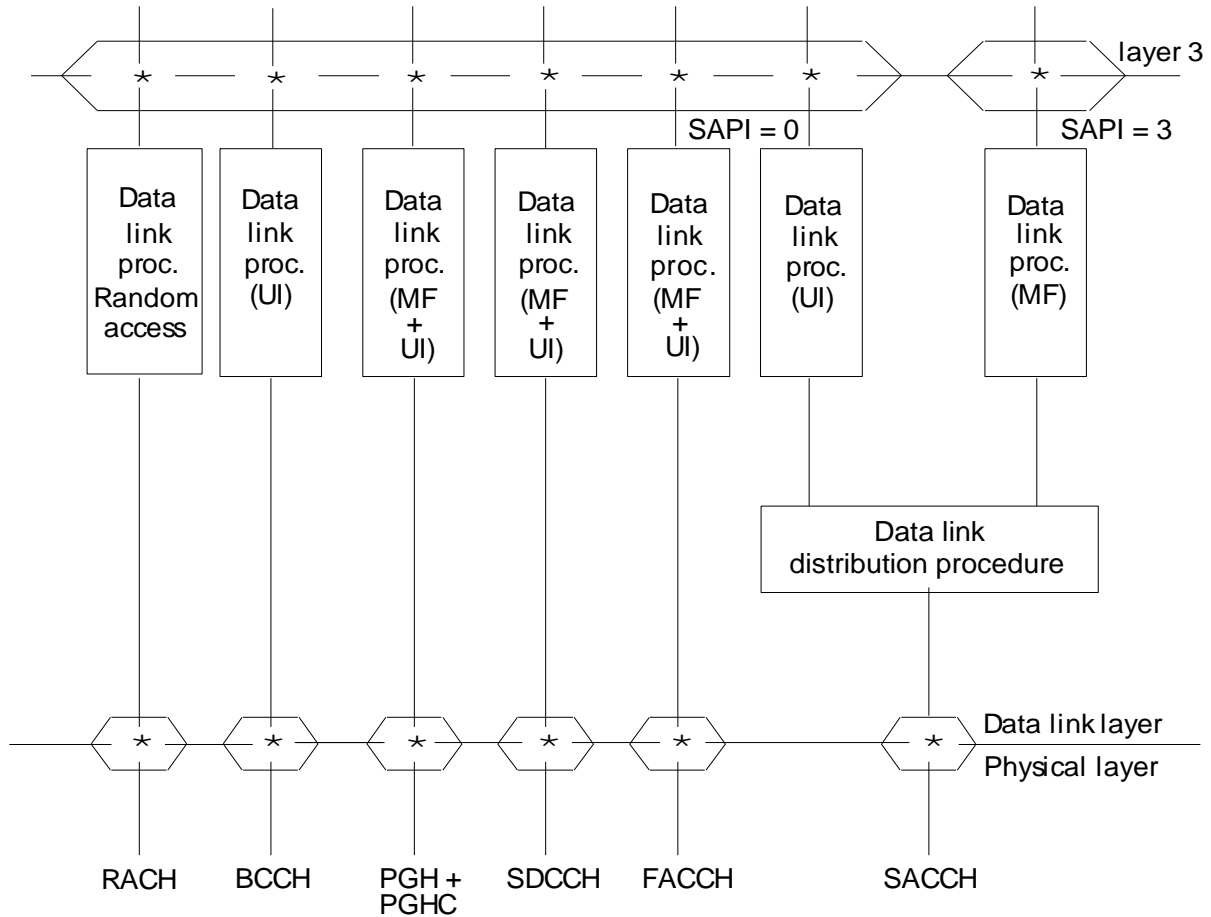

UI = unacknowledged
MF = multiple frame

Figure 5: Example of the data link layer configuration in the MS

6 Specific requirements

6.1 Mode of operation and allowed SAPs

The various types of channels shall support SAPs and modes of operation as follows:

Type of channel	SAPI = 0	SAPI = 3
BCCH	Unacknowledged	Not supported
CCCH	Unacknowledged	Not supported
SDCCH	Unacknowledged and acknowledged	Acknowledged
SACCH associated with SDCCH	Unacknowledged	Not Supported
SACCH associated with TCH	Unacknowledged	Acknowledged
FACCH	Unacknowledged and acknowledged	Not supported

6.2 Acknowledged mode of operation

6.2.1 Window size

The window size, k (see 3GPP TS 04.06), shall be:

- for SAPI = 0, $k = 1$;
- for SAPI = 3, $k = 1$.

Other SAPIs, for further study.

6.2.2 Processing capacity

The processing capacity of the MS and the network shall be big enough to avoid that the data link layer entities enter the receiver busy state for SAPI = 0.

Annex A (informative): Change History

Meeting/Date	CR	Change	New version
	-	-	V7.1.0
	A001	Addition of Preemption capability for SAPI 0 in LAPDm	-
	-	Version update to 8.0.1 for Publication	V8.0.1
May 2002	-	Format changed to 3GPP TS style	8.0.2