

ETSI TS 101 732 V8.0.0 (2000-03)

Technical Specification

**Digital cellular telecommunications system (Phase 2+);
Tandem Free Operation (TFO);
Service description;
Stage 2
(GSM 03.53 version 8.0.0 Release 1999)**



GSM®
GLOBAL SYSTEM FOR
MOBILE COMMUNICATIONS

ETSI 

Reference

DTS/SMG-110353Q7 (g1c03i0r.PDF)

Keywords

Digital cellular telecommunications system,
Global System for Mobile communications
(GSM), GSM, TFO

ETSI

Postal address

F-06921 Sophia Antipolis Cedex - FRANCE

Office address

650 Route des Lucioles - Sophia Antipolis
Valbonne - FRANCE
Tel.: +33 4 92 94 42 00 Fax: +33 4 93 65 47 16
Siret N° 348 623 562 00017 - NAF 742 C
Association à but non lucratif enregistrée à la
Sous-Préfecture de Grasse (06) N° 7803/88

Internet

secretariat@etsi.fr
Individual copies of this ETSI deliverable
can be downloaded from
<http://www.etsi.org>
If you find errors in the present document, send your
comment to: editor@etsi.fr

Copyright Notification

No part may be reproduced except as authorized by written permission.
The copyright and the foregoing restriction extend to reproduction in all media.

© European Telecommunications Standards Institute 2000.
All rights reserved.

Contents

| | |
|---|-----------|
| Intellectual Property Rights..... | 4 |
| Foreword..... | 4 |
| 1 Scope..... | 5 |
| 2 References..... | 5 |
| 3 Definitions and Abbreviations..... | 6 |
| 3.1 Definitions..... | 6 |
| 3.2 Abbreviations..... | 6 |
| 4 Main Concepts..... | 6 |
| 5 TFO Architecture and Transmission Mechanism..... | 6 |
| 5.1 TFO Access Interfaces and Reference Points..... | 6 |
| 5.2 General In-band Transmission Mechanism for TFO..... | 7 |
| 5.3 High-Level Functions Required for TFO..... | 7 |
| 6 Model of operation..... | 8 |
| 6.1 Overview..... | 8 |
| 6.2 TFO establishment phase..... | 8 |
| 6.2.1 Sending of TFO_REQ message by a BSS..... | 8 |
| 6.2.2 Monitoring of TFO_REQ by a BSS..... | 8 |
| 6.3 Transparency of transmission equipments..... | 8 |
| 6.3.1 Local disabling..... | 8 |
| 6.3.2 Transparency to TFO negotiation messages..... | 9 |
| 6.3.3 Transparency to TFO speech frames..... | 9 |
| 6.4 Modification of speech codec..... | 9 |
| 6.4.1 Introduction..... | 9 |
| 6.4.2 Exchanged parameters..... | 10 |
| 6.4.3 The exchanged parameters are the speech codec currently in use and the other possible codecs that can be used within the call Modification procedure..... | 10 |
| 6.4.4 Change of speech codec in the BSS..... | 10 |
| 6.5 TFO operation..... | 10 |
| 6.5.1 End to end delay..... | 10 |
| 6.5.2 Synchronisation between TRAU..... | 10 |
| 6.5.3 Monitoring in TFO operation..... | 11 |
| 6.5.4 DTX aspects..... | 11 |
| 6.5.5 Error concealment..... | 11 |
| 6.5.6 Management of UFE bit..... | 11 |
| 6.5.7 Handover management..... | 11 |
| 6.5.8 Other issues..... | 12 |
| 7 Compatibility Issues..... | 12 |
| 8 Interactions with Other Services..... | 12 |
| 8.1 General..... | 12 |
| 8.2 Support of DTMF..... | 12 |
| 9 Operational Aspects..... | 13 |
| Annex A (Informative): Change history..... | 14 |
| History..... | 15 |

Intellectual Property Rights

IPRs essential or potentially essential to the present document may have been declared to ETSI. The information pertaining to these essential IPRs, if any, is publicly available for **ETSI members and non-members**, and can be found in SR 000 314: "*Intellectual Property Rights (IPRs); Essential, or potentially Essential, IPRs notified to ETSI in respect of ETSI standards*", which is available **free of charge** from the ETSI Secretariat. Latest updates are available on the ETSI Web server (<http://www.etsi.org/ipr>).

Pursuant to the ETSI IPR Policy, no investigation, including IPR searches, has been carried out by ETSI. No guarantee can be given as to the existence of other IPRs not referenced in SR 000 314 (or the updates on the ETSI Web server) which are, or may be, or may become, essential to the present document.

Foreword

This Technical Specification (TS) has been produced by the Special Mobile Group (SMG).

The present document defines the stage 2 service description for Tandem Free Operation (TFO) in GSM. Tandem Free Operation applies only to speech calls.

The contents of the present document is subject to continuing work within SMG and may change following formal SMG approval. Should SMG modify the contents of the present document, it will be re-released by SMG with an identifying change of release date and an increase in version number as follows:

Version 7.x.y

where:

- 8 Indicates GSM Phase 2+ Release 1999;
- y the third digit is incremented when editorial only changes have been incorporated in the specification;
- x the second digit is incremented for all other types of changes, i.e. technical enhancements, corrections, updates, etc.

1 Scope

The present document defines the stage 2 service description for Tandem Free Operation (TFO) in GSM. Tandem Free Operation applies only to speech calls.

Note: the TFO principles are built so that they could be used as well by other systems other than GSM.

In analogy with CCITT Recommendations I.130 [2] and with reference to CCITT Recommendations VI.1 Q.65 (Stage 2 of the method for the characterisation of services supported by an ISDN), the second stage of the following three-level structure is derived from a stage 1 service description.

Stage 1 is an overall service description, from the service subscriber's and user's standpoints, that views the network as a single entity which provides services to the user.

Stage 2 identifies the functional capabilities and information flows needed to support the service described in stage 1. Furthermore, it identifies various possible physical locations for the functional capabilities. The output of Stage 2, which is signalling system independent, is used as an input to Stage 3, the design of signalling system and switching Recommendations.

Stage 3 defines the signalling system protocols and switching functions needed to implement the service described in stage 2.

2 References

The following documents contain provisions which, through reference in this text, constitute provisions of the present document.

- References are either specific (identified by date of publication, edition number, version number, etc.) or non-specific.
- For a specific reference, subsequent revisions do not apply.
- For a non-specific reference, the latest version applies.
- A non-specific reference to an ETS shall also be taken to refer to later versions published as an EN with the same number.
- For this Release 1998 document, references to GSM documents are for Release 1998 versions (version 7.x.y).

- [1] GSM 01.04 (ETR 350): "Digital cellular telecommunications system (Phase 2+); Abbreviations and acronyms".
- [2] CCITT Recommendations I.130 (1988): General modelling methods - Method for the characterisation of telecommunication services supported by an ISDN and network capabilities of an ISDN".
- [3] GSM 02.53: "Digital cellular telecommunications system (Phase 2+); Tandem Free Operation (TFO); Service description; Stage 1".
- [4] GSM 08.60 (ETS 300 737): "Digital cellular telecommunications system (Phase 2+); Inband control of remote transcoders and rate adaptors for Enhanced Full Rate (EFR) and full rate traffic channels".
- [5] GSM 08.61 (ETS 300 979): "Digital cellular telecommunications system (Phase 2+); In-band control of remote transcoders and rate adaptors for half rate traffic channels".

3 Definitions and Abbreviations

3.1 Definitions

Tandem Free Operation: corresponds to the Mobile-to-Mobile calls for which the speech is not transcoded two times but only one by the Mobile Stations.

3.2 Abbreviations

For the purposes of the present document, the following abbreviations apply:

| | |
|------|-----------------------|
| TFO: | Tandem Free Operation |
| IPE: | In Path Equipment |

Further abbreviations used may be found in GSM 01.04

4 Main Concepts

In-band TFO aims to remove the speech coding and decoding done in the BSS in MS-to-MS calls in order to improve the perceived speech quality. In-band TFO is established after call set-up using in-band signalling. This signalling is therefore controlled by the TRAU.

Using in-band signalling implies that the link between the TRAU is transparent in the sense that the digital content of what is emitted by a TRAU is not modified. The so-called In Path Equipments must therefore be disabled or configured in such a way that the information (signalling and coded speech) required for Tandem Free is not altered.

5 TFO Architecture and Transmission Mechanism

5.1 TFO Access Interfaces and Reference Points

The BSS reference points for TFO are described in Figure 1. GSM A interface reference point applies here with the exception (as compared with 08.02) that speech is not in the standard 64 kbit/s PCM format and between TFO TRAU in-band signalling is used. For speech and in-band signalling the MSC is transparent.

Additional transmission equipments are taken into account. These equipments are all those which can process the PCM signal between the two peer BSS, e.g. echo cancellers, DCME. The BSS to BSS transmission is then considered transparent provided no transmission equipment along the circuit do not modify the 2 LSB or these transmission equipments implement a TFO "transparency mode". A specific signalling allows to remotely control in-band these equipments.

BSS-MSC out-of-band signalling consists in this version of TFO of the normal BSSMAP signalling which carries the list of acceptable speech codec that may be used for the TFO negotiation mechanism.

Use of TFO specific out-of-band mechanism is not foreseen in that version of the specification.

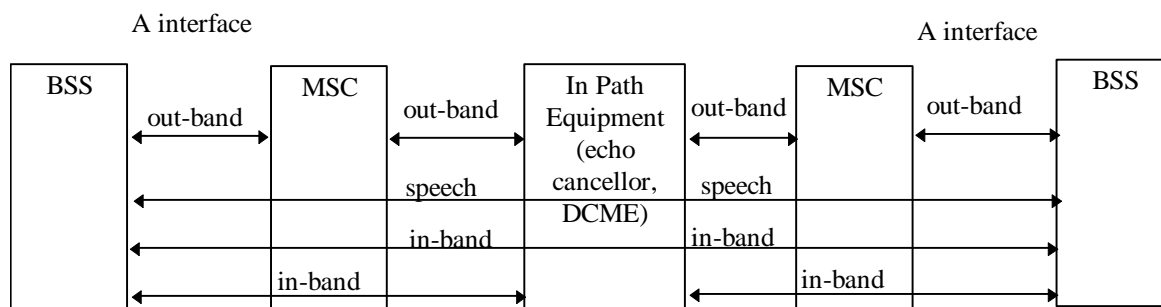

Figure 1

5.2 General In-band Transmission Mechanism for TFO

In TFO establishment mode, one bit out of 16 LSB bits is regularly stolen of the 64 kbits/s circuit. This provides for a 0.5kbits/s channel and has been selected so that the degradation on the speech quality is inaudible.

In TFO established mode and when the FR of EFR codec is used, bit stealing takes place on the 2 LSB bits (bits 7-8) on each PCM sample. This provides for a 16 kbits/s channel that allows to carry vocoded speech in TFO speech frames which are similar to the frames in 08.60. The contents of the 6 MSB (bits 1-6) is normal A/ μ -law information.

In TFO established mode and when the HR codec is used, bit stealing takes place on the LSB bit (bit 8) on each PCM sample. This provides for a 8 kbits/s channel that allows to carry vocoded speech in TFO frames which are similar to the 8 kbit/s frames in 08.61. The contents of bit 1-7 is normal A/ μ -law information.

5.3 High-Level Functions Required for TFO

The high level functions which apply to TFO are described hereafter. Not all these functions need necessarily to be covered by the first description of TFO since some issues may be too complex to solve in an initial stage or at all.

The list of functions which are applicable to the BSS follows:

- signalling a request message (TFO_REQ) on the A interface that the TRAU supports TFO;
- signalling an acknowledgement message (TFO_ACK) that the request message has been received from the peer entity;
- monitoring request and acknowledgement messages on the A interface that the peer entity supports TFO;
- remote control of echo cancellors, DCME, ...;
- signalling of current speech codec with acknowledgement message;
- signalling of speech codec capability with acknowledgement message;
- change of current speech codec within the BSS (optional);
- sending of TFO speech frames to the A interface;
- reception of TFO speech frames from the A interface;
- conversion of a flow of TRAU frames into TFO speech frames;
- conversion of a flow of TFO speech frames into TRAU frames.

The following function applies to IPEs that may be along the 64 kbits/s circuit, such as DCME or echo cancellers equipments:

- monitoring of TFO negotiation messages - repetition of LSB bit 8 one time out of 16 (TFO establishment mode, i.e reproduce at the output of the IPE the detected message);

- capability to go full or sub-64 kbit/s transparent mode and to resume normal operation based on TFO negotiation messages
- capability to monitor and alter TFO speech frame control information (optional);
- capability to insert TFO negotiation messages (optional).

No assumption is made currently on the interactions between call set-up as seen by the MSC and TFO. This means that the initial working assumption is that TFO works independently of the Call Control in the MSC, using only a mechanisms internal to the BSS to activate and de-activate TFO operation.

6 Model of operation

6.1 Overview

The TRAU must first identify each other as TRAU that are TFO capable. Next the TRAU must check that they're using the same speech codec. If they don't use the same speech codec they can inform the BSC in order to modify the speech codec used in the MS. If they're using the same speech codec the TRAU starts to insert TFO speech frames in the LSB(s) of the PCM octet present on the A interface. These frames contain the speech parameters as obtained from the uplink TRAU frames.

6.2 TFO establishment phase

6.2.1 Sending of TFO_REQ message by a BSS

The TFO_REQ message is sent using bit stealing on bit 8, by stealing one bit out of 16. This allows to have the least possible degradation of the PCM, since the TFO_REQ message is sent even in cases where TFO will not be possible e.g. MS to PSTN call.

6.2.2 Monitoring of TFO_REQ by a BSS

The monitoring of the TFO_REQ message can be performed by a BSS which is capable of TFO.

Upon reception of a TFO_REQ message, the BSS replies with an TFO_ACK message which can contain the following information:

- - system identification (GSM,...);
- - the current speech codec;
- - the list of supported speech codecs;
- - a random value that allows the detection of loop backs of a given BSS.

6.3 Transparency of transmission equipments

6.3.1 Local disabling

Not used.

6.3.2 Transparency to TFO negotiation messages

IPE which support TFO protocol need to first synchronise on "transparency patterns" contained in the in-band transmitted TFO messages (negotiation messages TFO_REQ, TFO_ACK) as discussed in subclause 6.2 and in addition track some specific TFO message (Go transparent command, Go to normal) needed to set the transparency mode required in TFO established mode or return to normal operation. Having synchronised to a transparency pattern, the IPE should reproduce at its output the TFO message in order to ensure transparency of the in-band signalling path. Some additional delay with respect to normal operation of the IPE may be introduced by the IPE as far as the in-band signalling information is concerned but such delay should be a multiple of 20ms. No delays should be introduced on other bits.

6.3.3 Transparency to TFO speech frames

As part of the TFO establishment, if TFO can be successfully established (same codec type) then each TRAU sends TFO negotiation messages (Go transparent commands) which indicate to the In Path Equipment (IPE) along the BSS to BSS circuit the type of IPE transparency mode. The TFO speech frame then contains a "keep open" pattern that maintains the operation of the IPE as commanded. That "keep open" pattern is part of the synchronisation pattern of each TRAU frame and does not require hence complete tracking of the TFO speech frames by the IPE (nevertheless the commands within the TFO negotiation messages should be checked continuously). IPE revert to normal operation in case the keep open pattern is absent for [1s] or a new command "Go to normal" is received.

IPE which support TFO protocol set the transparency mode as indicated in the received Gotransparent command after having reproduced the received Gotransparent command at its output. The IPE should simultaneously start to track the keep open pattern. Then the bits corresponding to the "transparent" path are copied in the 64 kbit/s output stream of the equipment. The delay introduced by the IPE on the TFO contained in the transparent part of the 64kbit/s should be less than or equal to the delay in normal operation.

These principles should be GSM independent, allowing other systems to use the same transparency principle.

The behaviour of the IPE regarding the remaining part of the circuit can be either of the following:

- the IPE is speech transparent, meaning that the upper bits in the 64 kbit/s output stream should contain PCM speech, that speech being obtained by running the IPE in its normal way, possibly reproducing the PCM at the input. IPE should keep the same alignment as present at the input between transparent LSB:s and upper bits containing the PCM speech;
- the IPE is non speech transparent, meaning that the IPE may strip the upper bits, if the IPE is the compressor part of an DCME. In such a case the peer IPE (the decompression part of the a DCME) should reproduce the speech from the received TFO frame). This implies that the DCME implements the decoding part of some GSM vocoders;
- half-duplex TFO capable IPE.

6.4 Modification of speech codec

6.4.1 Introduction

In the speech codec modification procedure BSS informs the peer BSS the GSM speech codec versions supported by the sending BSS (within the ongoing call) and tries to align the codecs using implicit rule and BSS internal means to make appropriate handover

The support of the informing and BSS internal modification procedures are optional for a BSS since it depends on the BSS internal capabilities. This means that TFO should be applicable even if the informing and modification are not supported by one of the two peer entities. In this case, TFO will be available if both BSS happen to use the same speech codec version.

6.4.2 Exchanged parameters

6.4.3 The exchanged parameters are the speech codec currently in use and the other possible codecs that can be used within the call Modification procedure

In the TFO request message (TFO_REQ), the BSS informs the fact that it supports TFO.

The possible modification procedure is started when the TFO request message from the peer BSS has been detected. It is not synchronised explicitly on Call Set-up states.

If both BSS receive a TFO_REQ indicating that the same speech codec is used, the modification is not necessary and the BSS can move to the TFO established mode.

If the speech codecs used on both sides are different, each BSS looks at the list of the acceptable speech codecs from the other BSS.

There is an implicit rule as to the speech codec that every BSS will try to use based on the current speech codec, the list of locally acceptable speech codecs, and the list of remotely acceptable speech codecs. Each BSS then tries if it supports it to perform a change of codec via a intra-BSS (normally intra-cell) handover.

When a handover has been performed, each BSS will reply to TFO_REQ by a new TFO_ACK message indicating the newly used speech codec. The process goes on until either the same codec is used, or no more change of codec is possible according to the fixed rule.

There is a timer that protects the TFO establishment phase. The BSS, after the timer has elapsed, stops sending TFO request messages, but continues the monitoring of the peer entity. This is in order not to degrade the communication if TFO cannot be established. To resume the TFO establishment phase, it will be up to the peer entity to send a new TFO_REQ message to initiate a new attempt of establishment/modification of TFO e.g. when a handover has occurred.

6.4.4 Change of speech codec in the BSS

This procedure is internal to the BSS. It can be based on the use of O&M frames on the Abis interface or on the use of a specific TRAU to BSC interface or on some other method.

6.5 TFO operation

6.5.1 End to end delay

The end to end delay is similar to normal MS-MS call in TFO operation within a 20 ms range.(

6.5.2 Synchronisation between TRAU

The synchronisation depends on the kind of bit stealing used:

- 0,5 kbits/s. There is a specific pattern one bit out of 16 on the LSB;
- 8 kbits/s. The synchronisation of GSM 08.61 is used;
- 16 kbits/s. The synchronisation of GSM 08.60 is used.

Some sub-part of the synchronisation patterns can be understood by transmission equipments as well.

There is no time alignment between TRAU.

6.5.3 Monitoring in TFO operation

A TRAU in TFO established mode monitors permanently the synchronisation with the peer TRAU entity

In case of loss of synchronisation, a timer is started. When the timer elapses, the TRAU sends normal PCM speech, reverts to non-TFO mode and starts re-establishment procedures.

6.5.4 DTX aspects

Each direction is independent from the DTX point of view. This leads to the following scenarios for the transfer of speech in one direction:

Table 1

| Uplink User A | Downlink User B |
|---------------|-----------------|
| DTX | DTX |
| DTX | no DTX |
| no DTX | DTX |
| no DTX | no DTX |

The sending BSS, when DTX is applied on the uplink direction, generates normal speech frames when no SID frame is received

When a SID frame is received in the uplink, the BSS sends a normal speech frame to the peer BSS. The fact that TRAU frame was a SID frame is indicated to the peer BSS.

When uplink DTX is applied and nothing is received from the MS by the BTS, i.e during comfort noise generation, normal speech frames are sent to the peer BSS. The fact that comfort noise generation was applied is indicated to the peer BSS.

Based on these information, the receiving BSS can perform the best action depending on its mode DTX/no-DTX. If DTX is applied, it is felt that the best is to re-use the SID frame that was received by the peer BSS, even if it means shifting in time the sending of the frame (because both radio physical layers are not synchronised).

6.5.5 Error concealment

The BSS which has received a bad frame in the uplink direction builds a normal speech frame which is sent to the peer BSS. the fact that it was a bad frame that has been rebuilt is indicated as well to the peer BSS (BFI indication).

6.5.6 Management of UFE bit

The UFE bit is managed as described in the GSM 08.60 for the GSM EFR and GSM 08.61 for the GSM HR.

6.5.7 Handover management

Different cases of handovers from the TRAU point of view will be encountered :

- 1) handover with modification of the TRAU on one side or, which is equivalent, no modification of TRAU but change of transcoder DSP;
- 2) intra-cell handover without modification of transcoder DSP;
- 3) inter-cell handover without modification of transcoder DSP.

In case 1, TFO will be interrupted and re-established if the newly allocated TRAU (TRAU B) is TFO capable. Indeed the newly allocated TRAU will start in normal mode and, if it is TFO capable, will immediately attempt to establish TFO. This will interrupt the reception of TFO frames at the TRAU in TFO mode (TRAU A). As defined in subclause 6.5.3, the synchronisation loss timer will elapse and TRAU A will revert to normal mode. TFO will then be re-established given TFO establishment attempts performed by the new TRAU.

The management of handover for cases 2 and 3 will depend on the time put to actually switch the communication from one traffic channel to another one in the intra-cell handover case or between base stations in the inter-cell handover case. If the handover is fast enough, i.e. the timers to detect the loss of synchronisation do not elapse, then the TFO will be maintained. In the opposite case there will be a fallback to regular tandem. Attempts to re-establish TFO shall be performed if both TRAU's are still TFO-capable.

6.5.8 Other issues

The bridging of the communication in the MSC can potentially interfere TFO. The conference bridge will prevent TFO operation as long as it is present. The TFO synchronisation pattern should be lost and both TRAU's should revert to non-TFO operation if the bridge is present. TFO operation will start again from the start when the bridge is removed (handover is performed).

7 Compatibility Issues

Since the radio interface is not modified, there is no compatibility issue with the MS. It is up to the second TRAU to make sure that what it sends to the BTS is compatible with the existing.

The compatibility issue is with end systems not supporting TFO.

The TFO negotiation message synchronisation patterns should be chosen such that no other system uses such a pattern for another purpose, and that this pattern cannot be generated by a peer entity which is not supporting TFO. This does not preclude other systems than GSM to use TFO since the type of system is part of the negotiation mechanism.

8 Interactions with Other Services

8.1 General

The identified interactions are with the supplementary and basic services that modify the configuration of a communication.

One example of Supplementary Service is Explicit Call Transfer, where a MS to MS communication can result in a MS to non-MS communication. Similarly, in a communication where user A is a Mobile user and User B is not a Mobile user become a communication between user A and user C where both are Mobile users. One example of Basic Service is Alternate speech and data, where TFO should not degrade the transitions between speech and data.

More generally, the identified interactions are all related to the transitions between a configuration where TFO is possible (and potentially used) and a configuration where TFO is not possible.

The consequence of a Multiparty Call is that TFO operation is not possible.

The interactions between TFO and Lawful Intercept are will depend on the capability of the devices used in such a case to not alter the in-band information (signalling and coded speech) required by the in-band TFO system. These devices can either use the 6- or 7- bit PCM available on the A-interface..

The SS that modifies the digital content of what is emitted by a TRAU will interrupt TFO. Nevertheless as soon as the transparency is re-established the TRAU's will attempt re-establishing TFO.

8.2 Support of DTMF

The existing DTMF could be applied independently of TFO. It should be noted that DTMF in TFO operation means Mobile Terminated DTMF which is currently excluded from the standard.

The DTMF when inserted by the MSC will interrupt the TFO since the TFO speech frames are modified when crossing the MSC.

The TFO must be reestablished as soon as possible when the DTMF insertion stops.

9 Operational Aspects

TFO feature shall be defined so that a TFO capable TRAU should be able to interact with a TFO non-capable TRAU without noticeable degradation of quality. It shall be possible to roll-out TFO on part of the network.

The TFO establishment protocol shall define timers to set e.g. the negotiation message transmission time or the time needed to declare the loss of synchronisation (see subclause 6.5.3). When setting the values of these timers it should be made sure that two sets of timers at both TRAU are consistent in order to allow TFO establishment. Given that both TRAU may be located in different PLMN and be manufactured by different companies, most of the timers will have to be initialised at pre-defined values.

Annex A (Informative): Change history

| SMG# | SPEC | CR | PHASE | VERS | NEW_VERS | SUBJECT |
|------|-------|--------------|-------|------|----------|--|
| | 03.53 | 30 Sept 1996 | | | 0.0.0 | Draft proposal |
| | 03.53 | 25 Nov 1996 | | | 0.0.0 | Draft proposal after comments |
| | 03.53 | 27 Jan 1997 | | | 0.0.1 | Version 0.0.0 has been presented to SMG3/WPA and joint SMG3/SMG11 in dec. 96. No comments were made. Only change is editorial on official TS GSM reference |
| | 03.53 | 29 June 1997 | | | 0.0.2 | Changes reflecting the last decisions in SMG11. |
| | 03.53 | 18 Aug 1997 | | | 0.1.0 | Changes reflecting the decisions in SMG11 TFO #6 - format of the messages - applicable to different systems - transparency principle for transmission equipments. |
| | 03.53 | 01 Aug 1997 | | | 0.1.1 | Changes reflecting the review in SMG11 TFO #8 in Bois D'Arcy - transparency of IPEs can be for 1 up to 8 bits - no fixed pattern is used for the 6 MSB - informative annex on IPE is added |
| | 03.53 | 08 Oct 1997 | | | 0.2.0 | Clarifications reflecting SMG11/TFO in Bois D'Arcy and SMG11 in Le Mans Incorporation of comments received by e-mail. Version for presentation to SMG3/SA |
| | 03.53 | 08 Nov 1997 | | | 0.3.0 | Addition of some text regarding the main concept, handover management, UFE bit management, interaction with Supplementary services. |
| | 03.53 | 08 Dec 1997 | | | 1.0.0 | Presented to SMG. The presented version was approved in SMG3/SA, but since it was not seen by SMG3, it was requested that it is presented again to SMG3, and was then only presented to SMG for information. |
| SMG# | SPEC | CR | PHASE | VERS | NEW_VERS | SUBJECT |
| S29 | 03.53 | | R98 | | 7.0.0 | Release 1998 version (new) |
| S31 | 03.53 | | R99 | | 8.0.0 | Release 1999 version (new) |
| | | | | | | |
| | | | | | | |

History

| Document history | | |
|-------------------------|------------|--------------------------|
| V7.0.1 | July 1999 | Publication |
| V8.0.0 | March 2000 | Version for Release 1999 |
| | | |
| | | |
| | | |