

## **GERAN Overall Description - Stage 2**

<Workitem> V<m.t.e> (2000-05>)

---

*Technical Specification*

**Digital cellular telecommunications system (Phase 2+);  
GSM/EDGE Radio Access Network (GERAN);  
Overall Description;  
Stage 2;  
(GSM 03.51 version 0.0.1 Release 2000)**

---



*European Telecommunications Standards Institute*

---

Reference

---

<Workitem>

Keywords

---

<keyword[, keyword]>

**ETSI Secretariat**

Postal address

---

F-06921 Sophia Antipolis Cedex - FRANCE

Office address

---

650 Route des Lucioles - Sophia Antipolis  
Valbonne - FRANCE  
Tel.: +33 4 92 94 42 00 Fax: +33 4 93 65 47 16  
Siret N° 348 623 562 00017 - NAF 742 C  
Association à but non lucratif enregistrée à la  
Sous-Préfecture de Grasse (06) N° 7803/88

X.400

---

c= fr; a=atlas; p=etsi; s=secretariat

Internet

---

secretariat@etsi.fr  
<http://www.etsi.fr>

---

**Copyright Notification**

Reproduction is only permitted for the purpose of standardization work undertaken within ETSI.  
The copyright and the foregoing restrictions extend to reproduction in all media.

© European Telecommunications Standards Institute yyyy.  
All rights reserved.

# Contents

Intellectual Property Rights.....	6
Foreword.....	6
Introduction.....	6
1 Scope.....	7
2 References.....	7
2.1 Normative references.....	7
2.2 Informative references.....	8
3 Definitions, symbols and abbreviations.....	8
3.1 Definitions.....	8
3.2 Symbols.....	8
3.3 Abbreviations.....	8
4 GERAN Architecture.....	8
4.1 Overall network architecture.....	8
4.2 GERAN Reference Architecture.....	9
4.3 User plane protocol architecture in PS domain.....	9
4.4 Control plane protocol architecture in PS domain.....	10
4.5 User plane protocol architecture in CS domain.....	10
4.6 Control plane protocol architecture in CS domain.....	10
4.7 Iur' protocol architecture.....	10
5 Radio Interface Protocol Architecture.....	10
6 User and Control Plane Protocols.....	11
6.1 Relay.....	11
6.2 Radio Resource Control (RRC).....	11
6.3 Packet Data Convergence Protocol (PDCP).....	11
6.3.1 Services provided to upper layers.....	11
6.3.2 Services expected from RLC layer.....	11
6.3.3 PDCP Functions.....	12
6.3.3.1 Transparent Mode.....	12
6.3.3.2 Non-Transparent Mode.....	12
6.4 Radio Link Control (RLC).....	12
6.4.1 Services provided to upper layer.....	13
6.4.2 RLC Functions.....	13
6.4.2.1 Transparent Mode.....	13
6.4.2.2 Non-Transparent Mode.....	13
6.4.2.2.1 Acknowledged Mode.....	13
6.4.2.2.2 Unacknowledged Mode.....	13
6.5 Medium Access Control (MAC).....	14
6.5.1 Services provided to upper layers.....	14
6.5.2 MAC Functions.....	14
6.5.2.1 Dedicated Mode.....	14
6.5.2.2 Shared Mode.....	14
6.6 Physical Layer (Phy).....	15
6.6.1 Definitions.....	15
6.6.2 Services provided to upper layer.....	15
6.6.2.1 Specific services of the physical layer in the MS.....	15
6.6.3 Logical Channels.....	16
6.6.3.1 Traffic channels.....	16
6.6.3.2 Control channels.....	16
6.6.3.2.1 Broadcast channels.....	16
6.6.3.2.2 Common control type channels.....	16
6.6.3.2.3 Dedicated control channels.....	16

6.6.3.2.4	Cell Broadcast Channel (CBCH).....	16
6.6.4	Physical Subchannels .....	17
6.6.4.1	DPSCH - Dedicated Physical SubChannel.....	17
6.6.4.2	SPSCH - Shared Physical SubChannel.....	17
6.6.5	Mapping of logical channels onto physical subchannels .....	17
6.6.5.1	DPSCH full rate .....	17
6.6.5.1.1	Multiframe mapping of logical channels onto DPSCH/F .....	17
6.6.5.2	DPSCH half rate .....	17
6.6.5.2.1	Multiframe mapping of logical channels onto DPSCH/H.....	17
6.6.5.3	DPSCH quarter rate .....	18
6.6.5.4	SPSCH full rate.....	18
6.6.5.4.1	Multiframe mapping of logical channels onto SPSCH/F .....	18
6.6.5.5	SPSCH half rate.....	18
6.6.5.5.1	Multiframe mapping of logical channels onto SPSCH/H .....	18
6.6.6	Physical Layer Functions .....	19
6.6.7	Channel Coding .....	20
7	Mobility Management and Session Management (MM and SM) .....	21
A.1	Conversational Radio Access Bearer.....	22
A.2	Streaming, Interactive, Background Radio Access Bearers .....	23
A.2.1	Streaming.....	23
A.2.2	Interactive .....	25
A.2.3	Background.....	26
Annex B (informative):	Bibliography .....	27
<b>Annex C (informative):</b>	<b>Document Change History .....</b>	<b>28</b>

# Intellectual Property Rights

Foreword

Introduction

# 1 Scope

This specification defines the stage-2 service description for a GSM/EDGE Radio Access Network (GERAN). CCITT I.130 describes a three-stage method for characterisation of telecommunication services, and CCITT Q.65 defines stage 2 of the method.

This document illustrates how the services requested by a GSM/UMTS Core Network are realized by the GERAN. There is no detailed description of the interfaces towards the core network and only references are given to the appropriate specifications.

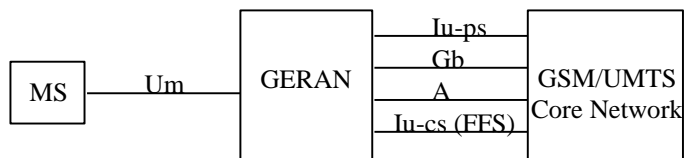

**Figure 1. GSM/EDGE Radio Access Network.**

---

## 2 References

References may be made to:

- a) specific versions of publications (identified by date of publication, edition number, version number, etc.), in which case, subsequent revisions to the referenced document do not apply; or
- b) all versions up to and including the identified version (identified by "up to and including" before the version identity); or
- c) all versions subsequent to and including the identified version (identified by "onwards" following the version identity); or
- d) publications without mention of a specific version, in which case the latest version applies.

A non-specific reference to an ETS shall also be taken to refer to later versions published as an EN with the same number.

### 2.1 Normative references

- [1] UMTS 25.410: "UTRAN Iu Interface: General Aspects and Principles".
- [2] UMTS 25.411: "UTRAN Iu interface Layer 1".
- [3] UMTS 25.412: "UTRAN Iu interface signalling transport".
- [4] UMTS 25.413: "UTRAN Iu interface RANAP signalling".
- [5] UMTS 25.414: "UTRAN Iu interface data transport & transport signalling".
- [6] UMTS 25.415 "UTRAN Iu interface user plane protocols".
- [7] GSM 08.14: "General Packet Radio Service (GPRS); Base Station System (BSS) - Serving GPRS Support Node (SGSN) interface; Gb interface Layer 1".
- [8] GSM 08.16: "General Packet Radio Service (GPRS); Base Station System (BSS) - Serving GPRS Support Node (SGSN) interface; Network Service".

- [9] GSM 08.18: “General Packet Radio Service (GPRS); Base Station System (BSS) - Serving GPRS Support Node (SGSN); BSS GPRS Protocol (BSSGP)”
- [10] GSM 05.01: “Digital cellular telecommunications system (Phase 2+); Physical layer on the radio path; General description”
- [11] GSM 05.02: “Digital cellular telecommunications system (Phase 2+); Multiplexing and multiple access on the radio path”

## 2.2 Informative references

- [12] UMTS 23.060: “General Packet Radio Service (GPRS); Service Description; Stage 2”
- [13] GSM 03.64: “General Packet Radio Service (GPRS); Overall description of the GPRS radio interface; Stage 2”
- [14] GSM 23.034: “High Speed Circuit Switched Data (HSCSD); Stage 2”

---

# 3 Definitions, symbols and abbreviations

## 3.1 Definitions

For the purposes of the present document, the following definitions apply:

**<defined term>**: <Definition>.

**example**: The text serving as an example.

## 3.2 Symbols

For the purposes of the present document, the following symbols apply:

<symbol>            <Explanation>  
<2<sup>nd</sup> symbol>      <2<sup>nd</sup> Explanation>

## 3.3 Abbreviations

For the purposes of the present document, the following abbreviations apply:

<ACRONYM1> <Explanation>  
<ACRONYM2> <Explanation>

---

# 4 GERAN Architecture

## 4.1 Overall network architecture

Editor's note: Insert text and figure on reference architecture from S2 report on all-IP.



## 4.2 GERAN Reference Architecture

The reference architecture of GERAN is illustrated in Figure 2. GERAN connects with an Iu-ps, Gb and A interface to the core network. It is for further study if an Iu-cs is needed. The Base Station Controllers (BSCs) may be connected to each other with an Iur' interface.

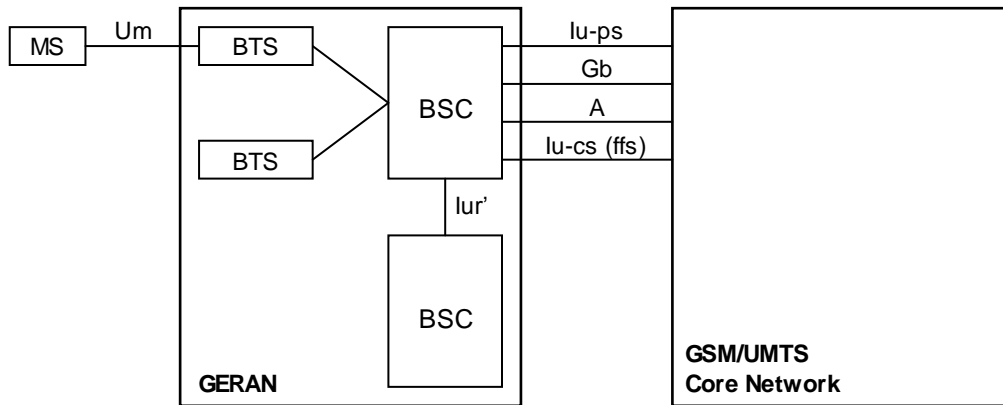

Figure 2. GERAN reference architecture.

## 4.3 User plane protocol architecture in PS domain

Figure 3 shows the user plane for GERAN connected to a packet switched core network domain. For reference, GPRS and UMTS protocol stacks when connected to the packet switched core network domain are depicted in Figures 4 of [12] and 6 of [12] respectively.

Specifications and more detailed descriptions of the Iu-ps interface protocols and architecture can be found in [1-6].

Specifications and more detailed descriptions of the Gb interface protocols and architecture can be found in [7-9].

The Um interface protocols are described in section 5 and 6.

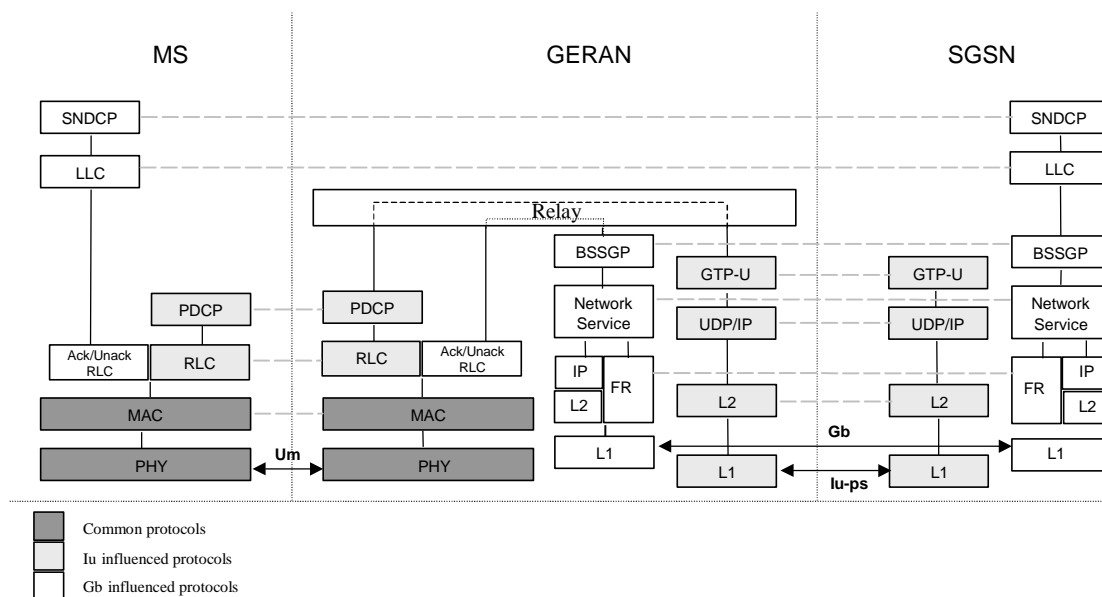

Figure 3. User Plane protocols towards Packet Switched Core Network domain.

#### 4.4 Control plane protocol architecture in PS domain

The control plane protocol architecture in the PS domain is FFS.

#### 4.5 User plane protocol architecture in CS domain

The user plane protocol architecture in the CS domain is FFS.

#### 4.6 Control plane protocol architecture in CS domain

The control plane protocol architecture in the CS domain is FFS.

#### 4.7 Iur' protocol architecture

The architecture and functionality of Iur' is FFS.

### 5 Radio Interface Protocol Architecture

The Radio Access Bearers offered by GERAN are aligned with those offered by UTRAN. Four different traffic classes, or types of radio access bearers, are defined: conversational, streaming, interactive and background. The approach used to create these radio access bearers in GERAN also resembles the UTRAN approach, in which combinations of different modes of protocols in one single stack provide a large set of radio bearers.

The Um user plane protocol stack of GERAN is shown in Figure 4. Different modes of PDCP, RLC and MAC, as well as different types of logical channels may be combined to create different types of radio bearers. The selection of protocol modes for a certain radio bearer is controlled by the GERAN Radio Resource Management (RR).

Informative examples of how radio access bearers may be created are given in Annex A. The MS capabilities for GERAN are given in [GSM 02.07].

The functionality provided by each protocol in each of its modes is described in the next Section.

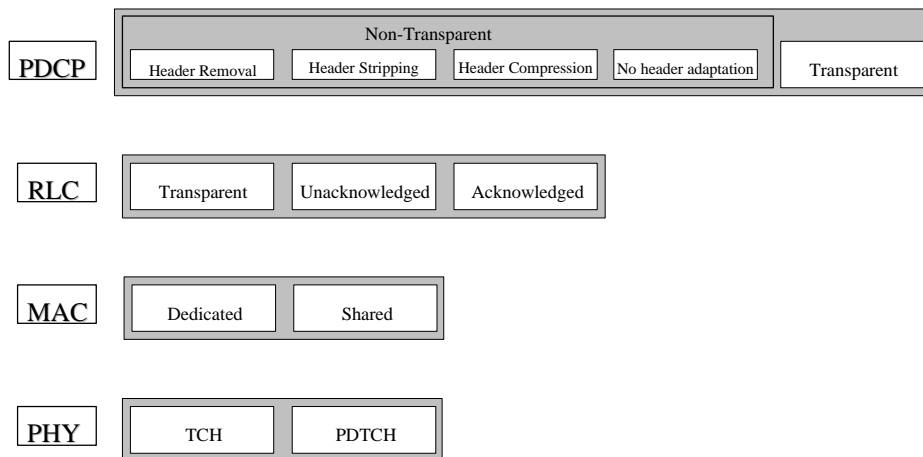

**Figure 4. GERAN user plane protocol stack over Um interface. Different protocol modes may be combined to create different radio bearer types.**

For a conversational class call, the GERAN offers the following multiplexing scenarios on the radio interface:

- **Operational Scenario 1.** Permanent allocation of a physical subchannel to a conversational class call, without any multiplexing capability.
- **Operational Scenario 2.** Permanent allocation of a physical subchannel to a conversational class call and multiplexing of best effort data from the same mobile station.

---

## 6 User and Control Plane Protocols

This section provides an overview on the user and control plane protocols of GERAN. For detailed description of each of the layer, please refer to the corresponding specification (see below).

### 6.1 Relay

The relay function of GERAN functionality and whether some functions need to be standardized are for FFS.

### 6.2 Radio Resource Control (RRC)

RRC is a control plane protocol for radio resource management. RRC design is FFS.

### 6.3 Packet Data Convergence Protocol (PDCP)

This section provides an overview on services and functions provided by the Packet Data Convergence Protocol (PDCP). A detailed description of the PDCP is given in [Ref: GERAN'00 PDCP – 25.323].

#### 6.3.1 Services provided to upper layers

The following services are provided by PDCP to upper layers:

- PDCP SDU delivery

#### 6.3.2 Services expected from RLC layer

- Data transfer in acknowledged mode.

- Data transfer in unacknowledged mode.
- Data transfer in transparent mode.
- Segmentation and reassembly.
- In-Sequence delivery.

### 6.3.3 PDCP Functions

For clarity reason, two PDCP modes are defined in this TS: transparent and non-transparent. The transparent and non-transparent modes relate respectively to the PDCP-no-header PDU and the PDCP-data PDU cases described in UMTS 25.323.

The functions performed by the PDCP are dependent on the PDCP mode used.

#### 6.3.3.1 Transparent Mode

The name "transparent" means that the PDCP layer does not change the incoming service data units (SDU), i.e. no header is added and possible TCP/IP or RTP/UDP/IP headers in the data are left untouched.

The functionalities of the transparent mode of PDCP are:

- **Transfer of user data**
- **Relocation of PDCP buffer**
- **PDCP SDU buffering**

#### 6.3.3.2 Non-Transparent Mode

The functionalities of the non-transparent mode of PDCP are:

- **Header adaptation** of the IP data streams
- **Transfer of user data**
- **PDCP SDU buffering**
- **Relocation support appropriate to applicable QoS requirements**
- **Multiplexing of radio bearers onto RLC entities**

Different header adaptation mechanisms may be used by the PDCP:

- **Header compression.** This method compresses the headers added by the transport and network layers.
- **Header stripping.** This method is a header compression mechanism dependent on how the data is transported in the lower layers (link and physical). Typically, all the transport and network layer headers are removed from the packets carrying voice samples.
- **Header removal.** This method is not a compression scheme. Transport and network layers are terminated at the network side and the payload only is transported to the mobile station. The IP headers are not regenerated at the mobile station side.

In case of header compression or header stripping, the network and higher layer protocols terminate at the mobile station.

## 6.4 Radio Link Control (RLC)

This section provides an overview on services and functions provided by the Radio Link Control (RLC). A detailed description of the RLC is given in [Ref: GERAN'00 RLC – 04.60 + ffs].

## 6.4.1 Services provided to upper layer

- **Transparent data transfer.** This service transmits higher layer PDUs without adding any protocol information.
- **Acknowledged data transfer.** This service transmits higher layer PDUs and guarantees delivery to the peer entity.
- **Unacknowledged data transfer.** This service transmits higher layer PDUs without guaranteeing delivery to the peer entity.
- **Notification of unrecoverable errors.** RLC notifies the upper layer of errors that cannot be resolved by RLC itself by normal exception handling procedures, e.g. by adjusting the maximum number of retransmissions according to delay requirements.

There is a single RLC connection per Radio Bearer.

## 6.4.2 RLC Functions

### 6.4.2.1 Transparent Mode

RLC has no functionality when operating in transparent mode. The incoming SDUs are transferred to the MAC layer without being altered. No upper layer protocol information is removed. No RLC protocol information is added. All necessary signalling is made out of band.

### 6.4.2.2 Non-Transparent Mode

#### 6.4.2.2.1 Acknowledged Mode

RLC has support for the following functions in acknowledged mode. For a detailed description, see GSM 04.60. In addition the RLC offers the possibility for adjusting the maximum number of retransmissions according to the delay requirements.

- **Segmentation** of upper layer PDUs into RLC data blocks.
- **Concatenation** of upper layer PDUs into RLC data blocks.
- **Padding** to fill out an RLC data block.
- **Backward Error Correction** (BEC) procedures enabling the selective retransmission of RLC data blocks. As for EGPRS R'99, either selective type I ARQ or selective type II hybrid ARQ (incremental redundancy) is used.
- **Reassembly** of RLC data blocks into upper layer PDUs.
- **In-sequence delivery** of upper layer PDUs.
- **Link Adaptation**

New services towards the Iu-ps interface using acknowledged RLC mode is based on the existing EGPRS R'99 modulation and coding schemes (MCS-1 to 9) if mapped on the PDTCH.

#### 6.4.2.2.2 Unacknowledged Mode

RLC has support for the following functions in unacknowledged mode. For a detailed description, see GSM 04.60. No backward error correction procedure is supported in this mode.

- **Segmentation** of upper layer PDUs into RLC data blocks.
- **Concatenation** of upper layer PDUs into RLC data blocks.
- **Padding** to fill out an RLC data block

- **Reassembly** of RLC data blocks into upper layer PDUs
- **Sequence number check** to detect lost RLC blocks.
- **Link Adaptation**

The unacknowledged RLC mode is based on MCS-1 to 9 if mapped onto a PDTCH. If the RAB is mapped onto a TCH or E-TCH new coding schemes could be considered. Examples of bitrates supported per timeslot for these coding schemes are 9.6, 14.4, 28.8, 43.2, and 32 kbps. Other timeslot bitrates are for FFS. Higher bitrates can be achieved by combining several timeslots.

For control signalling unacknowledged RLC is used as for (E)GPRS release 97/99 if the radio access bearer uses PDTCH. If a TCH or E-TCH is used control signalling is performed via the FACCH and SACCH.

## 6.5 Medium Access Control (MAC)

This section provides an overview on services and functions provided by the Medium Access Control (MAC). A detailed description of the MAC is given in [Ref: ffs].

### 6.5.1 Services provided to upper layers

The MAC layer allows the transmission over the physical layer of upper layer PDUs from one mobile station in dedicated mode, or one or more mobile stations in shared mode. A MAC mode is associated with a physical subchannel for use by one or more mobile stations (dedicated or shared mode respectively). The MAC layer handles the access to and multiplexing onto the physical subchannels.

- **Data transfer.** This service provides unacknowledged transfer of MAC SDUs between peer MAC entities. This service does not provide any data segmentation. Therefore, segmentation/reassembly function should be achieved by upper layer.

### 6.5.2 MAC Functions

The functions of MAC include:

- **Mapping between logical channels and physical subchannels.** The MAC is responsible for mapping of logical channel(s) onto the appropriate physical subchannel(s).

#### 6.5.2.1 Dedicated Mode

In dedicated mode, the MS is allocated a dedicated physical subchannel for exclusive use of the bearers it supports.

- **Priority handling between data flows of one mobile station.** Priorities are e.g. given by attributes of Radio Bearer services.
- **Multiplexing/demultiplexing of higher layer PDUs delivered to/from the physical layer on dedicated physical subchannels.** This function can be utilised when several upper layer services (e.g. RLC instances) can be mapped efficiently on the same physical subchannel (operational scenario 2).

#### 6.5.2.2 Shared Mode

In shared mode, traffic flows to/from one or more MSs may be multiplexed on the same physical subchannel.

- **Identification of different traffic flows of one or more MSs on the shared physical subchannels.** Inband identification is needed to address a flow to an MS in the downlink or identify a flow from an MS in the uplink.
- **Multiplexing/demultiplexing of higher layer PDUs delivered to/from the physical layer on shared physical subchannels.**

*[Editor's Note: The control plane is for FFS.]*

## 6.6 Physical Layer (Phy)

The physical layer (layer 1) is the lowest layer in the OSI Reference Model and it supports all functions required for the transmission of bit streams on the physical medium. This section provides an overview on services and functions provided by the Physical Layer. A detailed description of the physical layer is given in [Ref: 05 series].

### 6.6.1 Definitions

A **physical channel** is defined as one uplink and downlink timeslot/frequency repeated in each TDMA frame (see GSM 05.02).

A **logical channel** is defined by the type of data which is transferred and characterized by parameters such as channel coding and interleaving. It can be uni-directional or bi-directional [05.02]. Example: PDTCH/U, TCH/FS

A **channel combination** is defined as the combination of logical channels that is mapped on a certain physical channel [05.02]. Example: TCH/FS+FACCH/F+SACCH/TF

A **physical subchannel** is defined as a physical channel or a part of a physical channel and an associated multiframe structure. Example: PDCH.

### 6.6.2 Services provided to upper layer

The physical layer interfaces the Medium Access Control (MAC) sub-layer of Layer 2 and the Radio Resource Control (RRC) sub-layer of Layer 3. Through Service Access Points (SAP), the physical layer offers services described below:

– **Access capabilities:**

The physical layer offers logical channels and the transmission services associated to higher layers. Logical channels are multiplexed either in a fixed predefined manner (multiframe structure) or dynamically by the MAC on physical subchannels. Physical subchannels are the units scheduled on the radio medium. Some are reserved by the network for common use (e.g. a combination of CCCH and BCCH), others are assigned to dedicated connections with MSs (dedicated physical subchannels), or are assigned to a shared usage between MSs (shared physical subchannels). In time, the combination of logical channels used on an assigned physical subchannel may change.

– **Error detection:**

The physical layer offers an error protected transmission service, it includes error detection functions and to a lower level, error correction functions. Erroneous received frames are not offered to upper layers but may be notified to upper layer. The probability of one or more errors in a physical block transferred by the physical layer is defined in [Ref: GERAN'00 Phy - 05.05]. Due to not specified methods of quality detection, the probability of residual errors in transferred blocks may vary between implementations.

Editor's note: Encryption is ffs (location; function/service).

#### 6.6.2.1 Specific services of the physical layer in the MS

- **Measurement of the signal strength of neighbouring base stations.** Measurements are transferred to layer 3.
- **Measurement of the signal quality of the physical subchannel used.** Measurements are transferred to the MAC layer for reporting to the base station.
- **Cell/PLMN selection in idle mode or in packet mode.** In idle mode or in packet mode, the physical layer selects the best cell with its BCCH/CCCH (CPBCCH/CCCCH only for COMPACT and for packet mode only) in close co-operation with layer 3, meeting requirements for PLMN selection specified in [Ref: GERAN'00 Phy - 02.11].

## 6.6.3 Logical Channels

### 6.6.3.1 Traffic channels

Traffic channels (TCH's) are intended to carry either encoded speech or user data in dedicated MAC mode. TCH's can either be full rate (TCH/F) or half rate (TCH/H). Quarter rate TCH's (TCH/Q) are FFS.

Packet data traffic channels (PDTCH's) are intended to carry user data in either dedicated or shared MAC mode. PDTCH's can either be full rate (PDTCH/F) or half rate (PDTCH/H).

### 6.6.3.2 Control channels

Control channels are intended to carry signalling or synchronization data. Four categories of control channel are defined: broadcast, common, dedicated control channels and cell broadcast channel. Specific channels within these categories are defined in the subclauses following.

#### 6.6.3.2.1 Broadcast channels

GERAN shall reuse R99 broadcast channels. Any addition shall be made in a backwards compatible manner.

#### 6.6.3.2.2 Common control type channels

GERAN common control type channels shall be based on R99 common control type channels. Any addition shall be made in a backwards compatible manner.

#### 6.6.3.2.3 Dedicated control channels

##### **On a dedicated physical subchannel:**

- i) The Fast Associated Control channel (FACCH) associated to one TCH. FACCH can either be full rate (FACCH/F) or half rate (FACCH/H) depending whether it is associated to a full rate or half rate TCH. Quarter Rate FACCH (FACCH/Q) are FFS.
- ii) The Packet Associated Control channel (PACCH) associated to one PDTCH: The PACCH is bi-directional. PACCH/U is used for the uplink and PACCH/D for the downlink. PACCH can either be full rate (PACCH/F) or half rate (PACCH/H) depending whether it is associated to a full rate or half rate PDTCH.
- iii) The Slow Associated Control channel (SACCH) associated to one TCH and/or PDTCH. SACCH can either be full rate (SACCH/TF) or half rate (SACCH/TH) depending whether it is associated to a full rate or half rate traffic channel. Quarter Rate SACCH (SACCH/TQ) are FFS.
- iv) Inband signalling associated to one TCH is for FFS.

##### **On a shared physical subchannel:**

- i) The Packet Associated Control channel (PACCH): The PACCH is bi-directional. PACCH/U is used for the uplink and PACCH/D for the downlink. PACCH can either be full rate (PACCH) or half rate (PACCH/H) depending whether it is associated to a full rate or half rate PDTCH.
- ii) The Packet Timing advance Control CHannel uplink (PTCCH/U): Used to transmit random access bursts to allow estimation of the timing advance for one MS in packet transfer mode.
- iii) The Packet Timing advance Control CHannel downlink (PTCCH/D): Used to transmit timing advance updates for several MS. One PTCCH/D is paired with several PTCCH/U's.

#### 6.6.3.2.4 Cell Broadcast Channel (CBCH)

GERAN shall reuse R99 cell broadcast channel.



### 6.6.4 Physical Subchannels

Depending on the MAC mode, a physical subchannel can either be dedicated or shared.

All physical subchannels are bi-directional unless otherwise stated.

Unidirectional physical subchannels are ffs.

#### 6.6.4.1 DPSCCH - Dedicated Physical SubChannel

A dedicated physical subchannel shall be mapped on a 26-multiframe structure involving SACCH and idle bursts.

A DPSCCH can either be full rate or half rate. Quarter rate DPSCCH's are FFS.

#### 6.6.4.2 SPSCCH - Shared Physical SubChannel

A shared physical subchannel shall be mapped on a 52-multiframe structure involving PTCCCH and idle bursts.

A SPSCCH can either be full rate or half rate.

### 6.6.5 Mapping of logical channels onto physical subchannels

#### 6.6.5.1 DPSCCH full rate

Excluding CBCH, broadcast channels and common control type channels, the following are the possible ways in which channels can be combined onto a DPSCCH full rate:

- i) TCH/F + FACCH/F + SACCH/TF
- ii) TCH/F + FACCH/F + SACCH/TF + PDTCH/F + PACCH/F  
PDTCH and PACCH can occur only within the silent periods of a TCH
- iii) PDTCH/F + PACCH/F + SACCH/TF

##### 6.6.5.1.1 Multiframe mapping of logical channels onto DPSCCH/F

Figure 5 shows the multiframe mapping of the logical channels for DPSCCH/F.

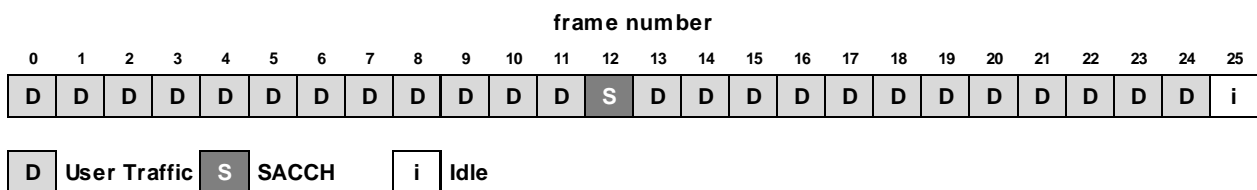

Figure 5. DPSCCH/F – Multiframe mapping of logical channels

#### 6.6.5.2 DPSCCH half rate

The following are the possible ways in which channels can be combined onto a DPSCCH half rate:

- i) TCH/H + FACCH/H + SACCH/TH
- ii) TCH/H + FACCH/H + SACCH/TH + PDTCH/H + PACCH/H  
PDTCH and PACCH can occur only within the silent periods of a TCH
- iii) PDTCH/H + PACCH/H + SACCH/TH

##### 6.6.5.2.1 Multiframe mapping of logical channels onto DPSCCH/H

Figure 6 shows the multiframe mapping of the logical channels for DPSCCH/H.



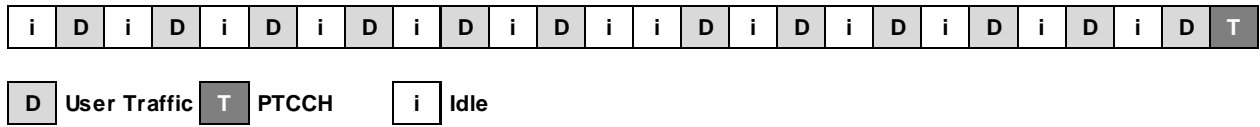

Figure 8. SPSCH/H – Multiframe mapping of logical channels

### 6.6.6 Physical Layer Functions

An overview of the functions which create the services of the physical layer can be found in [Ref: GERAN'00 Phy - 05.01].

### 6.6.7 Channel Coding

**Table 2: Channel Coding**

Logical Channel	Mod.	Radio Block / Frame Size (Bits)	SB (1)	Channel Coding		Interleaving			Physical Subchannel
				Type	Rate	Type	Depth (bursts)		
TCH/AFS	GMSK	464	8			diag	8		DPSCH/F
	8PSK	1392	24						
TCH/AHS	GMSK	232	4				4		DPSCH/H
	8PSK	696	12						
TCH/F	GMSK	See GSM 05.03							DPSCH/F (2)
	8PSK	See GSM 05.03		RS+CC	See [?]		19		
TCH/H	GMSK								DPSCH/H (2)
	8PSK			RS+CC	See [?]		19		
PDTCH/F	GMSK	464	12	CC	See [13]	rect	4		SPSCH/F
						ffs	ffs		DPSCH/F
									DPSCH/F (2)
	8PSK	1392	8			rect	4		SPSCH/F
									DPSCH/F
			8			ffs	ffs		DPSCH/F (2)
PDTCH/H	GMSK	464	12	CC	See [13]	rect	4		SPSCH/H
						ffs	ffs		DPSCH/H
									DPSCH/H (2)
	8PSK	1392	8			rect	4		SPSCH/H
									DPSCH/H
			8			ffs	ffs		DPSCH/H (2)

(1) The number of Stealing Bits (SB) is ffs

(2) For DPSCH, w hether TCH or PDTCH or both may be used is ffs.

Editor's Note: the table above remains to be completed.

---

## 7 Mobility Management and Session Management (MM and SM)

This section is ffs.

# Annex A (informative): Radio Access Bearer Realization

This annex describes how the different protocols of the GERAN User Plane protocol stack are configured to provide the desired radio access bearer classes (conversational, streaming, interactive and background). Only the traffic over Iu-ps interface is considered.

## A.1 Conversational Radio Access Bearer

In the table below, case A represents optimized conversational RAB further described in section A.1.2. Case B represents the generic conversational RAB.

**Table 2: Conversational RAB**

PDCP	RLC	MAC	Physical Layer							OS	
			Physical SubChannel	Traffic Channel			Dedicated Control Channel				
				Type	Interleav .	Mod.		Coding			
Non Transparent <i>Header Stripping</i>	Transp.	Dedicated	DPSCH/F	TCH/F	8 diag	GMSK	UEP	TCH/AFS	FACCH/F SACCH/TF	1 - 2	A
						8PSK (1)	UEP	TCH/AFS	FACCH/F SACCH/TF	1 - 2	
			DPSCH/H	TCH/H	4 diag	GMSK	UEP	TCH/AHS	FACCH/H SACCH/TH	1 - 2	
						8PSK	UEP	TCH/AHS	FACCH/H SACCH/TH]	1 - 2	
Non Transparent <i>Header Compression or No Adaptation</i> Transparent	Unack	Dedicated	DPSCH/F	PDTCH/F TCH/F (2)	ffs	GMSK	EEP	FACCH/F SACCH/TF PACCH/F	1 - 2	B	
						8PSK	EEP	FACCH/F SACCH/TF PACCH/F	1 - 2		
			DPSCH/H	PDTCH/H TCH/H (2)	ffs	GMSK	EEP	FACCH/H SACCH/TH PACCH/H	1 - 2		
						8PSK	EEP	FACCH/H SACCH/TH PACCH/H	1 - 2		

UEP Unequal Error Protection - EEP Equal Error Protection - OS Operational Scenario Supported

- (1) This row is intended for the realization of wide-band speech codec and is ffs
- (2) Whether TCH or PDTCH or both are used is ffs

## A.2 Streaming, Interactive, Background Radio Access Bearers

### A.2.1 Streaming

**Table 3: Streaming RAB**

PDCP	RLC	MAC	Physical Layer						OS
			Physical SubChannel	Traffic Channel			Dedicated Control Channel		
				Type	Interleav .	Mod.		Coding	
Non Transparent <i>Header Compression or No Adaptation</i> Transparent	Unack	Dedicated	DPSCH/F	PDTCH/F TCH/F (1)	ffs	GMSK	EEP	FACCH/F SACCH/TF PACCH/F	NA
						8PSK	EEP	FACCH/F SACCH/TF PACCH/F	NA
			DPSCH/H	PDTCH/H TCH/H (1)	ffs	GMSK	EEP	FACCH/H SACCH/TH PACCH/H	NA
						8PSK	EEP	FACCH/H SACCH/TH PACCH/H	NA
Non Transparent <i>Header Compression or No Adaptation</i> Transparent	Ack	Dedicated	DPSCH/F	PDTCH/F TCH/F (1)	ffs	GMSK	EEP	FACCH/F SACCH/TF PACCH/F	NA
						8PSK	EEP	FACCH/F SACCH/TF PACCH/F	NA
			DPSCH/H	PDTCH/H TCH/H (1)	ffs	GMSK	EEP	FACCH/H SACCH/TH PACCH/H	NA
						8PSK	EEP	FACCH/H SACCH/TH PACCH/H	NA
Non Transparent <i>Header Compression or No Adaptation</i> Transparent	Unack	Shared	SPSCH/F	PDTCH/F	ffs	GMSK	EEP	PACCH/F PTCCH/F	NA
						8PSK	EEP	PACCH/F PTCCH/F	NA
			SPSCH/H	PDTCH/H	ffs	GMSK	EEP	PACCH/H PTCCH/H	NA
						8PSK	EEP	PACCH/H PTCCH/H	NA
Non Transparent <i>Header Compression or No Adaptation</i> Transparent	Ack	Shared	SPSCH/F	PDTCH/F	ffs	GMSK	EEP	PACCH/F PTCCH/F	NA
						8PSK	EEP	PACCH/F PTCCH/F	NA
			SPSCH/H	PDTCH/H	ffs	GMSK	EEP	PACCH/H PTCCH/H	NA
						8PSK	EEP	PACCH/H PTCCH/H	NA

A

B

C

D

UEP Unequal Error Protection - EEP Equal Error Protection - OS Operational Scenario Supported

(1) Whether TCH or PDCTH or both are used is FFS



## A.2.2 Interactive

**Table 4: Interactive RAB**

PDCP	RLC	MAC	Physical Layer						OS
			Physical SubChannel	Traffic Channel				Dedicated Control Channel	
				Type	Interleav .	Mod.	Coding		
Non Transparent <i>Header Compression</i> <i>No Adaptation</i> Transparent	Ack	Dedicated	DPSCH/F	PDTCH/F	4 rect.	GMSK	EEP	PACCH/F SACCH/TF	FFS
						8PSK	EEP	PACCH/F SACCH/TF	FFS
			DPSCH/H	PDTCH/H	4 rect.	GMSK	EEP	PACCH/FH SACCH/TH	FFS
						8PSK	EEP	PACCH/H SACCH/TH	FFS
Non Transparent <i>Header Compression</i> <i>No Adaptation</i> Transparent	Ack	Shared	SPSCH/F	PDTCH/F	4 rect.	GMSK	EEP	PACCH/F PTCCH/F	NA
						8PSK	EEP	PACCH/F PTCCH/F	NA
			SPSCH/H	PDTCH/H	4 rect.	GMSK	EEP	PACCH/H PTCCH/H	NA
						8PSK	EEP	PACCH/H PTCCH/H	NA

A

B

UEP Unequal Error Protection - EEP Equal Error Protection - OS Operational Scenario Supported

## A.2.3 Background

**Table 5: Background RAB**

PDCP	RLC	MAC	Physical Layer						OS
			Physical SubChannel	Traffic Channel				Dedicated Control Channel	
				Type	Interleav.	Mod.	Coding		
Non Transparent <i>Header Compression</i> <i>No Adaptation</i> Transparent	Ack	Dedicated	DPSCH/F	PDTCH/F	4 rect.	GMSK	EEP	PACCH/F SACCH/TF	2
						8PSK	EEP	PACCH/F SACCH/TF	2
			DPSCH/H	PDTCH/H	4 rect.	GMSK	EEP	PACCH/FH SACCH/TH	2
						8PSK	EEP	PACCH/H SACCH/TH	2
Non Transparent <i>Header Compression</i> <i>No Adaptation</i> Transparent	Ack	Shared	SPSCH/F	PDTCH/F	4 rect.	GMSK	EEP	PACCH/F PTCCH/F	NA
						8PSK	EEP	PACCH/F PTCCH/F	NA
			SPSCH/H	PDTCH/H	4 rect.	GMSK	EEP	PACCH/H PTCCH/H	NA
						8PSK	EEP	PACCH/H PTCCH/H	NA

A

B

UEP Unequal Error Protection - EEP Equal Error Protection - OS Operational Scenario Supported

## Annex B (informative): Bibliography

The following material, though not specifically referenced in the body of the present document, gives supporting information.

- <Publication>: "<Title>".

---

## Annex C (informative): Document Change History

<b>Document history</b>		
0.0.1	2000-05-05	First version