

ETSI EN 300 903 V8.1.1 (2000-11)

European Standard (Telecommunications series)

**Digital cellular telecommunications system (Phase 2+);
Transmission planning aspects
of the speech service in the GSM
Public Land Mobile Network (PLMN) system
(GSM 03.50 version 8.1.1 Release 1999)**



GSM®
GLOBAL SYSTEM FOR
MOBILE COMMUNICATIONS

ETSI 

Reference

REN/SMG-110350Q8R1

Keywords

Digital cellular telecommunications system,
Global System for Mobile communications (GSM)

ETSI

650 Route des Lucioles
F-06921 Sophia Antipolis Cedex - FRANCE

Tel.: +33 4 92 94 42 00 Fax: +33 4 93 65 47 16

Siret N° 348 623 562 00017 - NAF 742 C
Association à but non lucratif enregistrée à la
Sous-Préfecture de Grasse (06) N° 7803/88

Important notice

Individual copies of the present document can be downloaded from:

<http://www.etsi.org>

The present document may be made available in more than one electronic version or in print. In any case of existing or perceived difference in contents between such versions, the reference version is the Portable Document Format (PDF). In case of dispute, the reference shall be the printing on ETSI printers of the PDF version kept on a specific network drive within ETSI Secretariat.

Users of the present document should be aware that the document may be subject to revision or change of status. Information on the current status of this and other ETSI documents is available at <http://www.etsi.org/tb/status/>

If you find errors in the present document, send your comment to:
editor@etsi.fr

Copyright Notification

No part may be reproduced except as authorized by written permission.
The copyright and the foregoing restriction extend to reproduction in all media.

© European Telecommunications Standards Institute 2000.
All rights reserved.

Contents

Intellectual Property Rights	7
Foreword	7
1 Scope	8
1.1 References.....	8
1.2 Abbreviations.....	10
1.3 Introduction	10
2 Network configurations	11
2.1 General	11
2.2 Model of the PLMN	11
2.3 Interfaces.....	11
2.4 Configurations of connections	12
2.4.1 General configurations of connections	12
2.4.2 Reference configurations to illustrate delay and echo control issues.....	12
2.5 4-wire circuits in the PLMN	12
3 Transmission performance	13
3.1 Overall Loss/Loudness ratings.....	13
3.1.1 Connections with handset MSs.....	14
3.1.2 Connections with handsfree MSs	14
3.1.3 Connections with headset MSs	14
3.2 Stability Loss.....	15
3.3 Delay	15
3.3.1 General	15
3.3.2 Sources of delay	15
3.3.2.1 Elements of the PLMN that cause delay	15
3.3.2.2 Elements of the PSTN that cause delay	16
3.3.3 Effects of delay	16
3.3.4 Allocation of delay to the PLMN	16
3.3.4.1 Allocation of delay to the PLMN when using a full rate system.....	16
3.3.4.2 Allocation of delay to the PLMN when using a half rate system.....	16
3.3.5 Delay of various network configurations.....	17
3.3.5.1 National and international connections with no echo control in the PSTN (reference configurations A).....	17
3.3.5.2 National and international connections with echo control in the PSTN (reference configurations B)	17
3.3.5.3 Connections where re-routeing leads to a significant increase in transmission path length (reference configurations C)	17
3.3.6 Delay related requirements on the MS.....	17
3.3.6.1 Full rate MS	17
3.3.6.2 Half rate MS	17
3.3.6.3 Handsfree MS	17
3.4 Echo	18
3.4.1 General	18
3.4.2 Electrical echo control in the PLMN (Reference configurations A).....	18
3.4.3 Acoustic echo control in the PLMN	18
3.4.3.1 Acoustic echo control in a handsfree MS	19
3.4.3.2 Acoustic echo control in a handset MS.....	19
3.4.3.3 Acoustic echo control in a headset MS.....	19
3.4.4 Interaction between tandem echo control devices (reference configurations B & C).....	19
3.5 Clipping	19
3.5.1 General	19
3.5.2 Properties of voice switches in the PLMN	19
3.5.3 Problems of tandem voice switching	20
3.6 Idle channel noise (handset and headset MS).....	20
3.6.1 Sending	20
3.6.2 Receiving	20

3.7	Noise contrast.....	20
3.7.1	General	20
3.7.2	Elements of a PLMN which can cause noise contrast impairment.....	21
3.7.3	Reduction of noise contrast	21
3.7.3.1	Reduction of noise contrast by limiting the noise received by the microphone	21
3.7.3.1.1	Headset MS.....	21
3.7.3.1.2	Handset MS.....	22
3.7.3.1.3	Handsfree MS.....	22
3.7.3.2	Reduction of noise contrast by insertion of comfort noise	22
3.7.4	Consequence of the introduction of high comfort noise levels on other voice-operated devices	22
3.8	Sensitivity/frequency characteristics.....	22
3.8.1	Headset and Handset MSs	22
3.8.1.1	Sending	22
3.8.1.2	Receiving.....	23
3.8.2	Handsfree MS	23
3.8.2.1	Sending	23
3.8.2.2	Receiving.....	24
3.9	Distortion (handset and headset MS).....	24
3.9.1	Sending	24
3.9.2	Receiving	25
3.10	Sidetone (handset and headset MS).....	26
3.10.1	Sidetone loss	26
3.10.2	Sidetone distortion	26
3.11	Out-of-band signals.....	26
3.11.1	Discrimination against out-of-band input signals.....	26
3.11.1.1	Handset and headset MS.....	26
3.11.1.2	Handsfree MS.....	26
3.11.2	Spurious out-of-band signals.....	27
3.11.2.1	Handset and headset MS.....	27
3.11.2.2	Handsfree MS.....	27
3.12	Requirements for information tones.....	27
3.13	Crosstalk.....	27
3.13.1	Near and far end crosstalk	27
3.13.2	Go/return crosstalk.....	27
3.14	MS Ambient Noise Rejection.....	28
3.14.1	Full-Rate, (TCH-FS) MS Ambient Noise Rejection (handset MS).....	28
3.14.2	Full-Rate, (TCH-FS) MS Ambient Noise Rejection (handsfree MS)	28
3.14.3	Half-Rate, (TCH-HS) MS and Dual-Rate (TCH-FS and TCH-HS) MS Ambient Noise Rejection	28
Annex A (informative): Considerations on the Acoustic Interface of the Mobile Station.....		37
A.1	Handsfree MS.....	37
A.2	Handset MS.....	37
A.3	Headset MS.....	37
A.4	Inter-reaction with DTX	37
Annex B (normative): Test considerations		38
B.1	Test signals.....	38
B.1.1	Sinusoidal signals	38
B.1.2	Artificial voice	38
B.2	Test signal levels.....	38
B.2.1	Sending.....	38
B.2.1.1	Handset and headset MSs	38
B.2.1.2	Office type Handsfree MS	38
B.2.1.3	Car type Handsfree MS.....	39
B.2.2	Receiving	39
B.3	Test rooms.....	39
B.3.1	Anechoic room.....	39

B.4	Test arrangement.....	40
B.4.1	Electro-acoustic equipment.....	40
B.4.2	Test arrangement for handsfree MS	41
B.4.2.1	Office type handsfree MS.....	41
B.4.2.2	Car type handsfree MS.....	41
B.4.2.3	Use of HATS for testing the receive characteristics of the car type handsfree MS.....	42
B.4.2.3.1	Equalization of HATS.....	42
B.4.2.3.2	Combination of ear signals.....	43
Annex C (normative):	Transmission requirements testing.....	44
C.1	Loudness ratings	44
C.1.1	Sending Loudness Rating (SLR) – Handset MS.....	44
C.1.2	Sending Loudness Rating (SLR) – Handsfree MS	44
C.1.3	Receiving Loudness Rating (RLR) – Handset MS.....	44
C.1.4	Receiving Loudness Rating (RLR) - Handsfree MS	45
C.2	Idle Channel Noise	45
C.2.1	Sending.....	45
C.2.2	Receiving	45
C.3	Sensitivity/frequency characteristics	45
C.3.1	Sending - Handset MS.....	45
C.3.2	Sending – Handsfree MS.....	46
C.3.3	Receiving - Handset.....	46
C.3.4	Receiving - Handsfree	47
C.4	Distortion	47
C.4.1	Sending.....	47
C.4.2	Receiving	47
C.5	Variation of gain with input level	48
C.5.1	Sending.....	48
C.5.2	Receiving	48
C.6	Sidetone	48
C.6.1	Talker sidetone (STMR).....	48
C.6.2	Listener sidetone (LSTR)	48
C.7	Sidetone distortion	49
C.8	Out-of-band signals	49
C.8.1	Discrimination against out-of-band input signal for handset and headset MS	49
C.8.2	Spurious out-of-band signals for handset and headset MS	49
C.8.3	Discrimination against out-of-band signals for handsfree MS	49
C.8.4	Spurious out-of-band emissions for handsfree MS.....	49
C.9	Acoustic echo loss.....	50
C.9.1	Acoustic echo loss – Handset MS	50
C.9.2	Acoustic echo loss – Handsfree MS.....	50
C.10	Delay for handsfree MS.....	51
C.10.1	Uplink	51
C.10.2	Downlink.....	51
C.10.3	Result.....	51
C.11	Ambient noise rejection	52
C.11.1	Full-Rate, (TCH-FS) MS Ambient Noise Rejection (handset MS).....	53
C.11.2	Full-Rate, (TCH-FS) MS Ambient Noise Rejection (handsfree MS)	53
C.11.3	Half-Rate, (TCH-HS) MS and Dual-Rate (TCH-FS and TCH-HS) MS Ambient Noise Rejection	53

Annex D (normative): MS delay requirement definition54
D.1 Full rate MS delay requirement definition54
D.2 Half rate MS delay requirement definition55

Annex E (informative): Adaptive gain control.....56

Annex F (informative): Change Request History57
History.....58

Intellectual Property Rights

IPRs essential or potentially essential to the present document may have been declared to ETSI. The information pertaining to these essential IPRs, if any, is publicly available for **ETSI members and non-members**, and can be found in ETSI SR 000 314: "*Intellectual Property Rights (IPRs); Essential, or potentially Essential, IPRs notified to ETSI in respect of ETSI standards*", which is available from the ETSI Secretariat. Latest updates are available on the ETSI Web server (<http://www.etsi.org/ipr>).

Pursuant to the ETSI IPR Policy, no investigation, including IPR searches, has been carried out by ETSI. No guarantee can be given as to the existence of other IPRs not referenced in ETSI SR 000 314 (or the updates on the ETSI Web server) which are, or may be, or may become, essential to the present document.

Foreword

This European Standard (Telecommunications series) has been produced by ETSI Technical Committee Special Mobile Group (SMG).

The present document describes the transmission planning aspects pertaining to the speech service within the digital cellular telecommunications system (Phase 2+).

The contents of the present document is subject to continuing work within SMG and may change following formal SMG approval. Should SMG modify the contents of the present document it will be re-released with an identifying change of release date and an increase in version number as follows:

Version 8.x.y

where:

- 8 indicates Release 1999 of GSM Phase 2+.
- x the second digit is incremented for all changes of substance, i.e. technical enhancements, corrections, updates, etc.
- y the third digit is incremented when editorial only changes have been incorporated in the specification.

National transposition dates	
Date of adoption of this EN:	24 November 2000
Date of latest announcement of this EN (doa):	28 February 2001
Date of latest publication of new National Standard or endorsement of this EN (dop/e):	31 August 2001
Date of withdrawal of any conflicting National Standard (dow):	31 August 2001

1 Scope

The present document describes the transmission planning aspects pertaining to the speech service in the GSM PLMN system. Due to technical and economic factors, there cannot be full compliance with the general characteristics of international telephone connections and circuits recommended by the ITU-T.

The present document gives guidance as to the precautions, measures and minimum requirements needed for successful interworking of the PLMN with the national and international PSTN. The present document identifies a number of routing and network configurations. The objective is to reach a quality as close as possible to ITU-T standards in order to safeguard the performance seen by PSTN customers.

1.1 References

The following documents contain provisions which, through reference in this text, constitute provisions of the present document.

- References are either specific (identified by date of publication, edition number, version number, etc.) or non-specific.
- For a specific reference, subsequent revisions do not apply.
- For a non-specific reference, the latest version applies.
- A non-specific reference to an ETS shall also be taken to refer to later versions published as an EN with the same number.
- For this Release 1999 document, references to GSM documents are for Release 1999 versions (version 8.x.y).

- [1] GSM 01.04: "Digital cellular telecommunications system (Phase 2+); Abbreviations and acronyms".
- [2] GSM 03.04: "Digital cellular telecommunications system (Phase 2+); Signalling requirements relating to routing of calls to mobile subscribers".
- [3] GSM 06.01: "Digital cellular telecommunications system (Phase 2+); Full rate speech processing functions".
- [4] GSM 06.10: "Digital cellular telecommunications system (Phase 2+); Full rate speech; Transcoding".
- [5] GSM 06.11: "Digital cellular telecommunications system (Phase 2+); Full rate speech; Substitution and muting of lost frames for full rate speech channels".
- [6] GSM 06.12: "Digital cellular telecommunications system (Phase 2+); Full rate speech; Comfort noise aspect for full rate speech traffic channels".
- [7] GSM 06.31: "Digital cellular telecommunications system (Phase 2+); Full rate speech; Discontinuous Transmission (DTX) for full rate speech traffic channels".
- [8] GSM 06.32: "Digital cellular telecommunications system (Phase 2+); Voice Activity Detection (VAD)".
- [9] GSM 06.02: "Digital cellular telecommunications system (Phase 2+); Half rate speech; Half rate speech processing functions".
- [10] GSM 06.20: "Digital cellular telecommunications system (Phase 2+); Half rate speech; Half rate speech transcoding".
- [11] GSM 06.21: "Digital cellular telecommunications system (Phase 2+); Half rate speech; Substitution and muting of lost frames for half rate speech traffic channels".

- [12] GSM 06.22: "Digital cellular telecommunications system (Phase 2+); Half rate speech; Comfort noise aspects for half rate speech traffic channels".
- [13] GSM 06.41: "Digital cellular telecommunications system (Phase 2+); Half rate speech; Discontinuous Transmission (DTX) for half rate speech traffic channels".
- [14] GSM 06.42: "Digital cellular telecommunications system (Phase 2+); Half rate speech; Voice Activity Detection (VAD) for half rate speech traffic channels".
- [15] I-ETS 300 245-2: "Integrated Services Digital Network (ISDN): Technical characteristics of telephony terminals: Part 2: PCM A-Law handset telephony".
- [16] ITU-T Recommendation G.103 (1998): "Hypothetical reference connections".
- [17] ITU-T Recommendation G.111 (1993): "Loudness ratings (LRs) in an international connection".
- [18] ITU-T Recommendation G.113 (1993): "Transmission impairments".
- [19] ITU-T Recommendation G.114 (1993): "Mean one-way propagation time".
- [20] ITU-T Recommendation G.121 (1993): "Loudness ratings (LRs) of national systems".
- [21] ITU-T Recommendation G.122 (1993): "Influence of national systems on stability, talker echo, and listener echo in international connections".
- [22] ITU-T Recommendation G.131 (1988): "Stability and echo".
- [23] ITU-T Recommendation G.165 (1993): "Echo cancellers".
- [24] ITU-T Recommendation G.223 (1988): "Assumptions for the calculation of noise on hypothetical reference circuits for telephony".
- [25] ITU-T Recommendation G.703 (1991): "Physical/electrical characteristics of hierarchical digital interfaces".
- [26] ITU-T Recommendation G.711 (1988): "Pulse code modulation (PCM) of voice frequencies".
- [27] ITU-T Recommendation G.712 (1992): "Transmission performance characteristics of pulse code modulation".
- [28] ITU-T Recommendation G.167 (1993): "Acoustic Echo Controllers".
- [29] ITU-T Recommendation M.1020 (1993): "Characteristics of special quality international leased circuits with special bandwidth conditions".
- [30] ITU-T Recommendation M.1025 (1993): "Characteristics of special quality international leased circuits with basic bandwidth conditioning".
- [31] ITU-T Recommendation M.1030 (1988): "Characteristics of ordinary quality international leased circuits forming part of private switched telephone networks".
- [32] ITU-T Recommendations M.1040 (1988): "Characteristics of ordinary quality international leased circuits".
- [33] ITU-T Recommendation O.132 (1988): "Specification for a quantizing distortion measuring apparatus using a sinusoidal test signal".
- [34] ITU-T Recommendation P.11 (1993): "Effect of transmission impairments".
- [35] ITU-T Recommendation P.34 (1993): "Transmission characteristics of hands-free telephones".
- [36] ITU-T Recommendation P.38 (1993): "Transmission characteristics of operator telephone systems (OTS)".
- [37] ITU-T Recommendation P.50 (1993): "Artificial voices".
- [38] ITU-T Recommendation P.51 (1993): "Artificial mouths".

- [39] ITU-T Recommendation P.64 (1993): "Determination of sensitivity/frequency characteristics of local telephone".
- [40] ITU-T Recommendation P.76 (1988): "Determination of loudness ratings; fundamental principles".
- [41] ITU-T Recommendation P.79 (1993): "Calculation of loudness ratings".
- [42] ITU-T Recommendation Q.35 (1988): "Technical characteristics of tones for the telephone service".
- [43] ITU-T Recommendation Q.551 (1994): "Transmission characteristics of digital exchanges".
- [44] ITU-T Blue Book (1988): "Volume V, Supplement 13: Noise spectra".
- [45] ISO 3 (1973): "Preferred numbers – series of preferred numbers".
- [46] ITU-T Recommendation P.57 (1996): "Artificial Ears".
- [47] ITU-T Recommendation P.58 (1993): "Head and Torso Simulator for Telephony".
- [48] I-ETS 300 245-3: "Integrated Services Digital Network (ISDN): Technical characteristics of telephony terminal: Part 3: PCM A-law loudspeaking and handsfree telephony".

1.2 Abbreviations

For the purposes of the present document, the abbreviations given in GSM 01.04 and the following apply.

ADC	Analogue to Digital Converter
ADPCM	Adaptive Differential Pulse Code Modulation
AEC	Acoustic Echo Control
BSC	Base Station Controller (excluding transmission systems)
BTS	Base Transceiver Station (excluding transmission systems)
DAC	Digital to Analogue Converter
DMR	Digital Mobile Radio
DSI	Digital Speech Interpolation
EEC	Electric Echo Control
EL	Echo Loss
ERP	Ear Reference Point
FDM	Frequency Division Multiplex
ISC	International Switching
LE	Local Exchange
LSTR	Listener Sidetone Rating
MRP	Mouth Reference Point
OLR	Overall Loudness Rating
PCM	Pulse Code Modulation
POI	Point of Interconnection (with PSTN)
RLR	Receiver Loudness Rating
SLR	Send Loudness Rating
STM	Sidetone Masking Rating
UPCMI	13-bit Uniform PCM Interface

1.3 Introduction

Since the transmission quality and the conversational quality of the PLMN will in general be lower than the quality of the PSTN connection due to coding distortion, delay, etc., only some transmission aspects can be brought in line with ITU-T Recommendations. It is therefore necessary to improve the overall quality as much as possible by implementing proper routing and network configurations.

It should be recognized that the transmission plan for the GSM PLMN cannot lead to major changes in the PSTN. However, it is important to use the improvements in the evolving PSTN (e.g. digitalization, introduction of echo cancellers) in an effective way.

The transmission requirements are in the first place based on international connections. When the quality is sufficient for international connections, it can be assumed that the national connections will have the same or better quality.

In order to obtain a sufficient quality in the connection, it is preferable to have digital connectivity between the Base Station System (BSS) and the international exchange. The PLMN requirements are based on this assumption. When this situation cannot be provided, a lower quality must temporarily be accepted.

The present document consists of two parts: one will deal with network configurations, the other with transmission performance.

The part about network configurations gives information about the reference connections, on which the transmission plan is based. Furthermore, some guidelines are presented for improvement of the transmission quality in the evolving (digital) PSTN.

The part about transmission performance gives mainly characteristics of the transmission between MS acoustic interface (MRP/ERP) and the interface between the PLMN and the PSTN (POI). For transmission aspects where it is impossible to give overall characteristics, it is in some cases necessary to make recommendations for individual parts of the equipment.

Annex A considers the effects of the type of acoustic interfaces of the MS.

2 Network configurations

2.1 General

The basic configuration for the interworking with the PSTN is shown in figure 1.

2.2 Model of the PLMN

A more detailed model of the PLMN used for the consideration of transmission planning issues for speech is shown in figure 2. This model represents the main functions required and does not necessarily imply any particular physical realization. Routing of calls is given in GSM 03.04.

Any acoustic echo control is not specifically shown as it will be provided by analogue processing of digital processing or a combination of both techniques.

2.3 Interfaces

The main interfaces identified within the GSM specifications are shown in figure 1. For the purposes of the present document, the Air Interface and the Point of Interconnect (POI) are identified along with two other interfaces, Interface Z and a 13-bit Uniform PCM Interface (UPCMI). These interfaces are needed to define the PLMN transmission characteristics and the overall system requirements.

The Air Interface is specified by GSM 05 series specifications and is required to achieve MS transportability. Analogue measurements can be made at this point by using the appropriate radio terminal equipment and speech transcoder. The losses and gains introduced by the test speech transcoder will need to be specified.

The POI with the PSTN will generally be at the 2 048 kbits/s level at an interface, in accordance with ITU-T Recommendation G.703. At the point, which is considered to have a relative level of 0 dB, the analogue signals will be represented by 8-bit A-law, according to ITU-T Recommendation G.711. Analogue measurements may be made at this point using a standard send and receive side, as defined in ITU-T Recommendations.

Interface Z might be used in the case of direct MSC to MSC connections. Interface Z is of the same nature as the POI.

The UPCMI is introduced for design purposes in order to separate the speech transcoder impairments from the basic audio impairments of the MS.

2.4 Configurations of connections

2.4.1 General configurations of connections

Figure 3 shows a variety of configurations of connections. There are a number of PSTN features which should be avoided from such connections. These include:

- 1) echo control devices in the international network. If present, and not disabled, these devices will be in tandem with PLMN echo cancellers and may introduce degradation;
- 2) satellite routings. The delay inherent in the connections when added to the PLMN delay, may result in conversational difficulties. Double satellite links are likely to cause severe difficulties and special precautions should be taken to avoid this situation under call forwarding arrangements;
- 3) Digital Speech Interpolation systems (DSI). There is likely to be an adverse interaction between DSI and DTX;
- 4) ADPCM. The distortion introduced by ADPCM on routes where PSTN echo control is not provided is likely to reduce the echo cancellation provided by the PLMN electric echo canceller;
- 5) significant differences in clock rates on non-synchronized digital network components. The resulting phase roll and slips are likely to degrade the performance of the PLMN echo canceller;
- 6) those analogue FDM routings which exhibit phase roll. Any phase roll due to the absence of synchronization between the carrier frequencies on the two directions of transmission is likely to degrade the performance of the PLMN echo canceller;
- 7) tandem connections of sources of quantization distortion. The PLMN speech transcoder is estimated to be equivalent to 7 QDUs between uniform PCM interfaces (see ITU-T Recommendation G.113).

It is recognized that on some connections it may not be feasible to avoid these features, but in many cases, especially if taken into account at the planning stage, this should be possible.

2.4.2 Reference configurations to illustrate delay and echo control issues

Three basic reference configuration types shown in figures 4 to 6 are defined to illustrate delay and echo control issues. Intermediate echo control devices as shown in the figures are disabled by appropriate signalling between the MSC and ISC or MSC and MSC.

Reference configurations A (see figure 4) represent national or international connections where there is no echo control device in the PSTN. These reference configurations include re-routings configurations where the overall delay of the transmission path has not been extended.

Reference configurations B (see figure 5) represent national or international connections where echo control is provided in the PSTN. These reference configurations include re-routings configurations where the overall delay of the transmission path has not been extended.

Reference configurations C (see figure 6) represent national or international connections where re-routings has led to an increase in the overall delay of the transmission path beyond recommended limits.

2.5 4-wire circuits in the PLMN

As shown in figure 2, the PLMN will usually contain transmission systems. Where present, they should provide 4-wire circuits.

In the case of digital circuits which do not include any speech processing devices, the overall system requirements of the PLMN will not be affected by the presence of the link.

In the case of analogue links, the transmission characteristics (e.g. attenuation, attenuation distortion, noise) will affect the overall system requirements of the PLMN. ITU-T Recommendations M.1020, M.1025, M.1030 and M.1040 describe several transmission characteristics for leased circuits. In cases where the analogue link introduces loss, provision will have to be made at the interface to restore the loss.

3 Transmission performance

The overall transmission performance of connections in alternate conversation mode can be considered as a summation of the effects of:

- 1) the audio part between the MRP/ERP and the UPCMI interface;
- 2) the speech transcoder part including the effects of radio transmission, and speech processing between the UPCMI and the POI;
- 3) the overall characteristics of the connection between POI and the other user.

There is not only a linear addition of these effects but there is also an influence from different parts of the connection on the performance of the speech transcoder and other speech processing devices.

Where possible, the transmission performance is specified between the MRP/ERP and the POI. Where this is not possible, the transmission aspects of the audio part mentioned above have been specified. The transmission aspects of the speech transcoder are specified in GSM 06 series specifications. In the following paragraphs, requirements are specified for the UPCMI, the Air Interface or the POI as appropriate.

The transmission requirements of the MS have been derived from the requirements of digital telephones stated in I-ETS 300 245-2 and 3.

MSs will have to work in a variety of environments ranging from quiet office locations to very noisy environments as found in moving cars. In noisy conditions, different values for the sending and receiving sensitivities relative to the nominal values can increase the performance of the terminal. Some guidance is given in annex E.

The overall transmission performance in full duplex conversation mode will also greatly depend on the performance of the echo control devices which may be included in the connection.

The handsfree requirements in the present document are designed to provide a basic level of performance and to avoid adverse interactions with other networks. Testing is carried out in one configuration in a vehicle, whilst this gives some confidence that the system can work in a typical environment, the testing is by no means complete. It is assumed that the manufacturer submits the handsfree system with the transducers fitted in reasonable locations within the vehicle (the transducers should not impede the normal operation of the vehicle or its fittings). Unusual installations should be agreed for suitability with the relevant Type Approval Authority before testing.

In a real vehicle installation, care should be taken to allow for the acoustic properties of that vehicle and the likely acoustic environment. It is important that the best possible coupling between the microphone and the MS user is achieved. Hence the microphone should be directional and mounted as close to the user's mouth as practical. The loudspeakers should be mounted in such a way that the maximum receive signal is directed at the user, rather than dissipated by the various obstacles in that vehicle, such as the seats.

Proper consideration for the noise environment and the direct coupling between the microphone and loudspeakers is necessary. Excessive noise coupled into the microphone can mask the MS user's send speech and potentially affect the operation of DTX. The vehicle noise environment can potentially mask the received speech, unless sufficient volume is provided. However, direct coupling between the transducers can cause annoying echo to be heard by the far end user.

Primary factors affecting the coupling between the loudspeaker(s) and microphone(s) include:

- 1) directionality of the microphone(s);
- 2) directionality of the loudspeaker(s);
- 3) location of the transducers in relation to each other and reflecting surfaces such as the windows and windscreen.

3.1 Overall Loss/Loudness ratings

The overall international connection involving PLMNs and the PSTN should meet the overall loudness rating (OLR) limits in ITU-T Recommendation G.111. The national parts of the connection should therefore meet the send and receive loudness rating (SLR, RLR) limits in ITU-T Recommendation G.121.

For the case where digital routeings are used to connect the PLMN to the international chain of circuits, the SLR and RLR of the national extension will be largely determined by the SLR and RLR of the PLMN. The limits given below are consistent with the national extension limits and long term objectives in CCITT Recommendation G.121.

The SLR and RLR values for the PLMN apply up to the POI. However, the main determining factors are the characteristics of the MS, including the analogue to digital conversion (ADC) and digital to analogue conversion (DAC). Hence, in practice, it will be convenient to specify loudness ratings to the Air Interface. For the normal case, where the PLMN introduces no additional loss between the Air Interface and the POI, the loudness ratings to the PSTN boundary (POI) will be the same as the loudness ratings measured at the Air Interface. However, in some cases loss adjustment may be needed for interworking situations in individual countries.

These values are directly applicable to the case of an MS operating in a conventional non-mobile noise environment. Studies have shown that under the PLMN noise environment, speech levels are likely to be higher. Hence, in order to avoid clipping in the speech transcoder, the value of SLR may need to be increased.

NOTE: In annex C, measurement of SLR and RLR for handset MS is specified using sinusoidal test frequencies. This may not be the optimum method of measuring the loudness ratings because of the adaptive characteristics of the GSM speech transcoders. However the actual measurement is only performed over the linear portion of the MS. When developing the subsequent test methods for handsfree MS, in annex B and annex C, it was decided to use the artificial voice described in ITU-T Recommendation P.50, to measure send and receive sensitivities.

3.1.1 Connections with handset MSs

The nominal values of SLR/RLR to the POI shall be:

- SLR = 8 +/- 3 dB;
- RLR = 2 +/- 3 dB.

Where a user-controlled receiving volume control is provided, the RLR shall meet the selected nominal value for at least one setting of the control. When the control is set to maximum, the RLR shall not be less than (louder than) – 13 dB.

With the volume control set to the minimum position the RLR shall not be greater than (quieter than) 18 dB.

Compliance shall be checked by the tests described in annex C, clauses C.1.1 and C.1.3.

NOTE: The mechanical design of some MSs may make it impossible to seal the earpiece to the knife edge of the ITU-T artificial ear. Minimal additional methods may be used to provide the seal provided that they do not affect the mounting position of the MS with respect to the Mouth Reference Point and the Ear Reference Point.

3.1.2 Connections with handsfree MSs

The nominal values of SLR/RLR to/from the POI should be:

- SLR = 13 +/- 4 dB;
- RLR = 2 +/- 4 dB.

Compliance shall be checked by the tests described in annex C, clause C.1.2 and C.1.4.

Where a user controlled volume control is provided, the RLR shall meet the nominal value at one setting of the control. It is recommended that a volume control giving at least 15 dB increase from the nominal RLR (louder) is provided for handsfree units intended to work in the vehicle environment. This is to allow for the increased noise volume in a vehicle.

3.1.3 Connections with headset MSs

The SLR and RLR should be measured and computed using methods given in ITU-T Recommendation P.38. This Recommendation currently gives a measuring technique for supra-aural earphone and insert-type receivers. Study is continuing on other types of earpieces in ITU-T SGXII.

The nominal values of SLR/RLR to/from the POI should be:

- SLR = 8 +/- 3 dB;
- RLR = 2 +/- 3 dB with any volume control set to mid position.

Where a user-controlled receiving volume control is provided, the RLR shall meet the selected nominal value for at least one setting of the control. When the control is set to maximum, the RLR shall not be less than (louder than) -13 dB.

With the volume control set to the minimum position the RLR shall not be greater than (quieter than) 18 dB.

3.2 Stability Loss

The stability loss presented to the PSTN by the PLMN at the POI should meet the principles of the requirements in clauses 2 and 3 of ITU-T Recommendation G.122. These requirements will be met if the attenuation between the digital input and digital output at the POI is at least 6 dB at all frequencies in the range 200 Hz to 4 kHz under the worst-case acoustic conditions at the MS (any acoustic echo control should be enabled).

For the normal case of digital connection between the Air Interface and the POI, the stability requirement can be applied at the Air Interface. The worst-case acoustic conditions will be as follows (with any volume control set to maximum):

- Handset MS:** the handset lying on, and the transducers facing, a hard surface with the earpiece uncapped;
- Hands free MS:** no requirement other than echo loss;
- Headset MS:** for further study.

NOTE: The test procedure will need to take into account the switching effects of echo control and DTX.

3.3 Delay

3.3.1 General

A significant propagation time between the two ends of a connection causes difficulties in conversation over the connection. This arises from two causes. Firstly, the signal is reflected back from the distant end causing an echo to the talker (this is considered in clause 3.4). Secondly, even if ideal echo control were achieved, the delay between a user talking and receiving a reply from the user at the distant end of the connection could cause conversational difficulty.

PLMNs will be connected to the PSTN at a point where present planning rules allow for a delay of less than 12 ms (see ITU-T Recommendation G.114 clause 2.2 a). The delay within the PLMN will greatly exceed this. If unacceptable circuit delays are not to be experienced by users, action will have to be taken when planning routes or during call set-up.

3.3.2 Sources of delay

3.3.2.1 Elements of the PLMN that cause delay

The delay of the PLMN is made up of the following elements:

- 1) speech transcoding delay;
- 2) radio channel coding delay;
- 3) PLMN network delay (i.e. fixed elements such as multiplexing, propagation, switching, echo control);
- 4) speech processing for echo cancelling and noise reduction in Handsfree Mode.

3.3.2.2 Elements of the PSTN that cause delay

ITU-T recommendation G.114 identifies various elements present in some PSTN connections which cause delay. These include:

- 1) coaxial, radio and optical fibre terrestrial transmission systems;
- 2) geostationary satellites;
- 3) digital speech interpolators;
- 4) digital exchanges (see also ITU-T recommendation Q.551);
- 5) echo cancellers.

3.3.3 Effects of delay

Some recent studies have suggested that under ideal conditions, i.e.:

- 1) effective control of all echoes without clipping by the use of good echo cancellers;
- 2) low background noise leading to an absence of perceptible noise contrast;
- 3) low distortion of transmitted signals;
- 4) ideal loudness ratings.

Users can tolerate a circuit delay well in excess of 400 ms (currently the maximum delay recommended in ITU-T Recommendation G.114). Other studies indicate that the difficulty caused by circuit delay increases when impairments, such as imperfect echo control caused by echo suppressers, clipping and noise contrast, are present.

However, the mobile environment is very harsh, with high background noise levels and distortion from the speech transcoder. In particular, the use of acoustic echo suppression could give rise to severe speech clipping and noise contrast. Also the operation of the voice switching used with DTX will give impairments similar to those caused by echo suppression. All subjective tests performed with echo suppressers indicate that, because of the increased effect of clipping with increased delay, the difficulty experienced by users increases rapidly with delay. According to curve 2 of figure A.1 of ITU-T Recommendation G.114, the percentage of users experiencing difficulties with echo suppressers reaches 20% with a delay of 150 ms rising to 40% with a delay of 300 ms. ITU-T Recommendation G.114 annex A details the test conditions under which this curve was derived and it concludes that connections with more than 300 ms can only be used by very disciplined users who are aware of the problems involved in such a connection. However, recent work has indicated that delays of up to 500 ms can be used satisfactorily, provided that effective echo cancellation is incorporated in the link.

3.3.4 Allocation of delay to the PLMN

3.3.4.1 Allocation of delay to the PLMN when using a full rate system

Taking account of Recommendations on the separate factors described in clause 3.3.2.1, the maximum both-way in the PLMN between the MRP/ERP and the Point of Interconnection (see figure 1) will be 180 ms. In the case that the transcoder is positioned outside the BTS, the maximum distance between the POI and the furthest border of the cell controlled by the BTS is limited by a one-way propagation delay of 1,5 ms (approximately 300 km). If the transcoder is positioned at the BTS, the limit is 6,5 ms (approximately 1 300 km). These limits may be subject to increase resulting from savings made in the overall network.

3.3.4.2 Allocation of delay to the PLMN when using a half rate system

If it is assumed that the speech quality associated with the half rate system is the same as the full rate system (considering both the speech transcoder and the radio sub-system), then in order to achieve the same overall transmission quality, the maximum delay within the PLMN should be maintained at 180 ms.

3.3.5 Delay of various network configurations

3.3.5.1 National and international connections with no echo control in the PSTN (reference configurations A)

Reference configurations A (see figure 4) contain no echo control in the PSTN because present planning rules require the use of echo control devices only when the PSTN delay between two fixed PSTN users exceeds 25 ms. This leads to a maximum PSTN delay of 22 ms from the point of interconnection to the PLMN (see clause 3.4.2).

3.3.5.2 National and international connections with echo control in the PSTN (reference configurations B)

Reference configurations B (see figure 5) contain echo control in the PSTN because present planning rules require their use when the PSTN delay between PSTN users exceeds 25 ms. However, action may have to be taken by administrations when planning routes or at call set-up to limit the maximum delay.

Subclause 3.3.3 describes how the impairments from the harsh mobile environment when coupled with delay can give rise to difficulty. If very good cancellation of both electrical and acoustic echo can be achieved and there are no sources of speech clipping or noise contrast either in the PLMN or the PSTN part of the connection, the circuit delay should be kept below 400 ms. This means that every attempt should be made to avoid mobile to mobile calls via satellite (expected delay > 440 ms).

If acoustic echo suppression is used or DTX is enabled, or there is any other source of clipping or noise contrast present in the PSTN, the additional distortion introduced makes it desirable to avoid any satellite routing whenever possible in order to keep the delay below 300 ms.

3.3.5.3 Connections where re-routing leads to a significant increase in transmission path length (reference configurations C)

A number of possible combinations of re-routing are described by reference configurations C (see figure 6), all of which increase the path length and hence the delay and some of which increase the number of impairments in the network.

These routings are likely to cause severe degradation to the quality of the connection and may result in significant difficulty, particularly when the connection contains one or maybe more satellite links.

These connections should be avoided in network planning and, if this is not possible, then the facilities of Signalling System No. 7 should be used to control the routing of the call at call set-up to minimize the effects.

3.3.6 Delay related requirements on the MS

3.3.6.1 Full rate MS

In accordance with the outline of transmission delays in various GSM system elements contained in GSM 03.05, the round trip delay in the MS shall not exceed 143,9 ms as defined in annex D.

3.3.6.2 Half rate MS

The round trip delay in the MS shall not exceed 143,9 ms as defined in annex D.

3.3.6.3 Handsfree MS

The round trip delay in the MS, including the handsfree processing stages, shall not exceed 143,9 ms + 39 ms. The 143,9 ms is as defined in annex D, the 39 ms is to allow for additional processing for handsfree.

The method of measurement is defined in annex C, clause C.10.

3.4 Echo

3.4.1 General

There are two main sources of echo:

- 1) acoustic echo caused by the acoustic path between receive and transmit transducers;
- 2) electrical echo caused by coupling between the transmit and receive directions of transmission. The primary source of this form of echo is a two-to-four wire converter.

Electrical echo can be eliminated by the use of end-to-end four-wire transmission. Acoustic echo will be generated in all telephone instruments with the exception of carefully designed headsets.

In general, electrical echo is characterized by a short reverberation time and low dispersion while acoustic echo is likely to have a longer reverberation time and greater dispersion. The case of the acoustic echo may be further complicated by the time variant nature of acoustic echo which may be more severe in the mobile environment.

Curves showing the tolerance to echo, taking account of the relationship between the delay and the level of the echo, are given in ITU-T Recommendation G.131 figure 2/G.131. In practice, it has been found that for any connection with a delay of greater than 25 ms, some form of echo control will be required to reduce the level of the echo (ITU-T Recommendation G.131 Rule M).

With the expected maximum one-way delay in the PLMN of 90 ms, acoustic echo control will be required in the MS to reduce the echo returned to the distant end and electrical echo control will be required at the POI to reduce the echo returned to the PLMN user from the PSTN. The design of these echo control devices should be such as to provide operation in full duplex mode (as opposed to alternate mode).

The echo loss (EL) presented by the PLMN at the POI should be at least 46 dB during single talk. This value takes into account the fact that a MS is likely to be used in a wide range of noise environments. This requirement should be met for handset and handsfree MSs. Compliance shall be checked by the test described in annex C, clause C.9.

3.4.2 Electrical echo control in the PLMN (Reference configurations A)

The electrical echo control device at the interface with the PSTN should meet the requirements given in ITU-T Recommendation G.165, but with an end delay of 60 ms. This refers to t_d in clause 3.2 of

ITU-T Recommendation G.165. The 60 ms is calculated as follows. ITU-T Recommendation G.131 states that the maximum length of connection which need not have echo control has a mean one-way propagation time of 25 ms. However, this figure is the sum of the delays of the international connection and the maximum national delays at each end of the connection. Since the interconnection of the PLMN to the PSTN is unlikely to be at a point where the PSTN delay is > 22 ms, and the dispersion may be up to 8 ms, the maximum expected end delay which the echo canceller in the MSC should expect is:

$$(22 + 8) \times 2 = 60 \text{ ms} \quad (\text{see figure 7}).$$

Certain countries on the geographical limits of a continent may need to increase this limit as there may be a proportion of connections which do not comply with ITU-T Recommendation G.131 having a mean one-way delay of greater than 25 ms and yet are not provided with echo control.

3.4.3 Acoustic echo control in the PLMN

Acoustic echo control provided in the MS should provide a TCLw of 46 dB at the POI (see clause 3.4.1) over the likely range of acoustic end delays. If acoustic echo control is provided by voice switching, comfort noise should be injected. This comfort noise shall operate in the same way to that used in Discontinuous Transmission system (DTX). Effectively, the acoustic echo loss is provided by MS as the GSM network is zero loss from the air interface to the POI and hence the 46 dB requirement should be applied to the MS.

3.4.3.1 Acoustic echo control in a handsfree MS

The TCLw for the handsfree MS shall be 40 dB at the nominal setting of the volume control in quiet background conditions and 33 dB at the maximum user selectable volume control setting. If acoustic echo control is provided using some form of echo cancellation technique, the cancellation algorithm should be designed to cope with the expected reverberation and dispersion. In the case of the handsfree MS, this reverberation and dispersion may be time variant.

3.4.3.2 Acoustic echo control in a handset MS

The TCLw for the handset MS shall be 46 dB. Careful acoustic design of the handset body and selection of the mouth and ear piece transducers may facilitate the required acoustic echo loss without the need for active echo control techniques. However, should echo cancellation be employed the echo canceller should be capable of dealing with the variations in handset positions when in normal use. The implications of this are under study.

3.4.3.3 Acoustic echo control in a headset MS

The TCLw for a headset MS shall be 46 dB. Due to the obstacle effect of the head in this type of terminal, careful design might mean that no active echo control is necessary.

3.4.4 Interaction between tandem echo control devices (reference configurations B & C)

On long international routes or routes containing a satellite path, network echo control devices will be present in accordance with ITU-T Recommendation G.131 Rule M. These devices will be echo suppressers or echo cancellers generally with centre clippers. The tandem connection of such devices can lead to increased clipping and, if echo suppressers are used, additional loss. It is recommended that signalling or routing means be used to avoid the tandem connections of echo control devices whenever possible (see figure 7).

3.5 Clipping

3.5.1 General

The loss of the start or the end of a speech burst is known as clipping, the main cause of which is voice switching controlled by voice activity detection. Voice switching occurs in devices within the network or within terminal devices. The following devices employ voice switching:

- 1) echo suppressers. These are generally located at an ISC at either end of a long international connection or connections using satellites;
- 2) echo cancellers with centre clippers. These are located as for the echo suppressers above. In addition, it is recommended that they be used in the MSC at the interface with the PSTN. Clipping in these devices arises from the action of the centre clipper only;
- 3) digital speech interpolators (DSI). These devices are used in circuit multiplication equipment's which are often employed on international connections;
- 4) discontinuous transmission (DTX) devices. These are located in the PLMN;
- 5) loudspeaking telephones. These are used in the PSTN and in the PLMN. It should be noted that regulations in certain countries prohibit the use of handheld MSs by drivers of moving vehicles.

3.5.2 Properties of voice switches in the PLMN

GSM 06.32 specifies the requirements for the voice activity detector used for DTX and the total clipping allowed in the MS. Any voice switching used for acoustic echo control should not exceed these limits. Information on recommended characteristics of handsfree telephones is given in clause 5 of ITU-T Recommendation P.34.

3.5.3 Problems of tandem voice switching

The effect of tandem voice switches which are not under one common control will be an increase in clipping. Moreover, under conditions of high or rapidly changing ambient noise, false detection of speech is likely to occur in the voice activity detectors in DSI equipment or network echo control devices. These devices are generally designed for constant and low levels of noise.

In order to minimize clipping, the following action should be taken:

- 1) intermediate tandem voice switching devices in the network should be either disabled by signalling means or avoided by routing means;
- 2) the voice switching for the MS for acoustic control and for DTX should be under one common control.

However, it should be noted that, in many cases, it will not be possible to exclude DSI equipment or loudspeaking telephones from the connection.

3.6 Idle channel noise (handset and headset MS)

3.6.1 Sending

The maximum noise level produced by the apparatus at the UPCMI under silent conditions in the sending direction shall not exceed -64 dBm_{0p}.

NOTE 1: This level includes the eventual noise contribution of an acoustic echo canceller under the condition that no signal is received.

NOTE 2: This figure applies to the wideband noise signal. It is recommended that the level of single frequency disturbances should be 10 dB lower (ITU-T Recommendation P.11).

Compliance shall be checked by the test described in annex C, clause C.2.1.

3.6.2 Receiving

The maximum (acoustic) noise level at the handset and headset MS when no signal (O-level) is received from the speech transcoder shall be as follows:

- if no user-controlled receiving volume control is provided, or, if it is provided, at the setting of the user-controlled receiving volume control at which the RLR is equal to the nominal value, the noise measured at the ERP contributed by the receiving equipment alone shall not exceed -57 dBPa(A) when driven by a PCM signal corresponding to the decoder output value number 1;
- where a volume control is provided, the measured noise shall also not exceed -54 dBPa(A) at the maximum setting of the volume control.

NOTE: In a connection with the PSTN, noise conditions as described in ITU-T Recommendation G.103 can be expected at the input (POI) of the PLMN. The characteristics of this noise may be influenced by the speech transcoding process (for further study).

Compliance shall be checked by the test described in annex C, clause C.2.2.

3.7 Noise contrast

3.7.1 General

On any PLMN call there is likely to be continuous background noise which is present regardless of whether the users are talking or not. There may also be one or more voice-operated devices; these effectively break the circuit when there is no speech on it.

Noise contrast problems are caused by the background noise being interrupted when the circuit is broken so that the user listening on the circuit hears the background noise being continually switched on and off. This is particularly disturbing for a user talking to a PLMN user in a moving vehicle because the background noise being modulated in this way is at a very high level. In this situation, it has been found that speech intelligibility can be impaired.

The main sources of background noise are:

- 1) background acoustic noise picked up by the microphone. For a loudspeaking telephone in a moving vehicle the speech/noise ratio can be as low as 0 dB;
- 2) idle channel noise. This includes noise generated in the transmission system (thermal noise and crosstalk) the switching system and in speech transcoders.

3.7.2 Elements of a PLMN which can cause noise contrast impairment

The following elements can cause noise contrast impairments:

- 1) the acoustic echo control device in the MS. A moving vehicle presents a very difficult environment for an echo canceller, so an echo suppresser is likely to be used (possibly in conjunction with an echo canceller). Echo suppressers contain voice-operated switches;
- 2) DTX. The transmitter switching will cause a PSTN user talking to a PLMN user to hear modulation of the mobile background noise. It will also cause the PLMN user to hear modulation of the PSTN noise. The PSTN noise will vary from connection to connection and should decrease in the future with increasing network digitalization;
- 3) the electric echo control devices protecting the PLMN user against echo returned from the PSTN. The centre clipper in this echo canceller will cause some noise modulation.

3.7.3 Reduction of noise contrast

A reduction in noise contrast:

- 1) reduces conversational difficulty, particularly for long conversations;
- 2) allows a greater tolerance on the matching of the level and spectrum of the comfort noise to the ambient noise.

NOTE: Preliminary tests in vehicles indicate that, in a constant noise environment with a handsfree MS and a signal-to-noise ratio of approximately 10 dB, a maximum level mismatch of 2 dB can be tolerated. The comfort noise spectrum was a reconstruction of the averaged medium term ambient noise spectrum.

3.7.3.1 Reduction of noise contrast by limiting the noise received by the microphone

The characteristics of the ambient noise (spectrum and level) depend on the environment in which the MS is used. As a microphone is characterized by its sensitivity and directivity, only part of this noise will enter the microphone.

A general principle for reducing noise contrast is to maximize the signal-to-noise ratio at the microphone input. This can be achieved by simultaneously increasing directivity, reducing sensitivity, and placing the microphone close to the mouth of the talker. Consequently, the implementation of the acoustic terminal will significantly affect the dynamic range of the noise contrast.

3.7.3.1.1 Headset MS

In the case of a headset and if DTX is disabled, then noise contrast will not be present since acoustic echo control (with centre clipping) is not required. If DTX is enabled, then only a small amount of noise contrast might result since the microphone would be close to the talker's mouth and would follow the movement of the talker's head, thus fulfilling the general principle described above. In the worst case, the headset is likely to give a minimum of 15 dB signal-to-noise ratio (this value is for further study).

3.7.3.1.2 Handset MS

In the case of a handset, and if DTX is disabled, then noise contrast will not be present if optimized echo cancelling techniques (without residual echo clipping) are used to control the acoustic echo (providing 46 dB EL). If DTX is enabled or acoustic echo control with centre clipping is used, then only a small amount of noise contrast might result since the microphone would be close to the talker's mouth and would follow the movement of the talker's head, thus fulfilling the general principle described above. In the worst case, the handset is likely to give a minimum of 15 dB signal-to-noise ratio (this value is for further study).

3.7.3.1.3 Handsfree MS

In the case of a handsfree telephone and even if DTX is disabled, noise contrast will be introduced unless 46 dB EL can be provided without the use of centre clipping. This is unlikely to be achievable. As the microphone is distant from the talker's mouth, and as the talker may be moving during the conversation, the sensitivity of the microphone has to be high and directivity low. This could result in a worse case signal-to-noise ratio of 0 dB. (This value is for further study.)

The following is given as interim guidelines. In the case of a vehicle mounted handsfree MS, the characteristics of the microphone should be such as to limit the change in speech level to 5 dB for all positions of the talker while sitting.

3.7.3.2 Reduction of noise contrast by insertion of comfort noise

GSM 06.12 specifies comfort noise to be used both for acoustic echo control with centre clipping and DTX.

3.7.4 Consequence of the introduction of high comfort noise levels on other voice-operated devices

Two problems associated with other voice switching devices (e.g. DSI) may result from the introduction of high levels of comfort noise:

- 1) the high comfort noise level may be interpreted as a voice signal;
- 2) if the high level of comfort noise is detected as noise, then another source of comfort noise at a different level may be introduced downstream, thus increasing the noise contrast.

3.8 Sensitivity/frequency characteristics

3.8.1 Headset and Handset MSs

3.8.1.1 Sending

The sensitivity/frequency characteristics shall be as follows.

The sending sensitivity – frequency response, measured either from MRP to digital interface or from MRP to the SS audio output (digital output of the reference speech decoder of the SS), shall be within a mask which can be drawn between the points given in table 1. The mask is drawn with straight lines between the breaking points in table 1 on a logarithmic (frequency) – linear (dB sensitivity) scale.

Table 1: Sending sensitivity/frequency mask

Frequency (Hz)	Upper limit	Lower limit
100	-12	-
200	0	-
300	0	-12
1 000	0	-6
2 000	4	-6
3 000	4	-6
3 400	4	-9
4 000	0	-

All sensitivity values are dB on an arbitrary scale.

Compliance shall be checked by the test described in annex C, clause C.3.1.

3.8.1.2 Receiving

The sensitivity/frequency characteristics shall be as follows.

The receiving sensitivity – frequency response, measured either from the digital interface to the ERP or from the SS audio input (analogue or digital input of the reference speech encoder of the SS) to the ERP, shall be within the mask which can be drawn with straight lines between the breaking points in table 2 on a logarithmic (frequency) – linear (dB sensitivity) scale.

Table 2: Receiving sensitivity/frequency mask

Frequency (Hz)	Upper limit	Lower limit
100	-12	-
200	0	-
300	2	-7
500	*	-5
1 000	0	-5
3 000	2	-5
3 400	2	-10
4 000	2	-

All sensitivities are dB on an arbitrary scale.

* = The limit at intermediate frequencies lies on a straight line drawn between the given values on a log (frequency) – linear (dB) scale.

Compliance shall be checked by the test described in annex C, clause C.3.3.

3.8.2 Handsfree MS

3.8.2.1 Sending

The sending sensitivity frequency response from the MRP to the SS audio output (digital output of the reference speech decoder of the SS) shall be as follows.

The sending sensitivity frequency response shall be within the mask which can be drawn with straight lines between the breaking points in table 3 on a logarithmic (frequency) – linear (dB sensitivity) scale.

Table 3: Handsfree sending sensitivity/frequency response

Frequency (Hz)	Upper limit	Lower limit
200	0	
250	0	
315	0	-14
400	0	-13
500	0	-12
630	0	-11
800	0	-10
1 000	0	-8
1 300	2	-8
1 600	3	-8
2 000	4	-8
2 500	4	-8
3 100	4	-8
4 000	0	

All sensitivity values are dB on an arbitrary scale.

Compliance shall be checked by the test described in annex C, clause C.3.2.

3.8.2.2 Receiving

The receiving sensitivity frequency response from the SS audio input (analogue or digital input of the reference speech encoder of the SS) to the ERP shall be as follows.

The receiving sensitivity frequency response shall be within the mask which can be drawn with straight lines between the breaking points in table 4 on a logarithmic (frequency) – linear (dB sensitivity) scale.

Table 4: Handsfree receiving sensitivity/frequency response

Frequency (Hz)	Upper limit	Lower limit
200	0	
250	0	
315	0	-15
400	0	-12
500	0	-12
630	0	-12
800	0	-12
1 000	0	-12
1 300	0	-12
1 600	0	-12
2 000	0	-12
2 500	0	-12
3 100	0	-12
4 000	0	

All sensitivity values are dB on an arbitrary scale.

Compliance shall be checked by the test described in annex C, clause C.3.4.

3.9 Distortion (handset and headset MS)

3.9.1 Sending

The sending part shall meet the following distortion requirements.

NOTE: Digital signal processing other than the transcoder itself is included in this requirement (e.g. echo cancelling).

Distortion shall be measured either between MRP and the UPCMI or between MRP and the SS audio output (digital output of the reference speech decoder of the SS). The ratio of signal-to-total distortion power measured with the proper noise weighting (see table 3 of ITU-T Recommendation G.223) shall be above the limits given in table 5 unless the sound pressure at MRP exceeds +10 dBPa.

Table 5: Limits for signal-to-total distortion ratio

Sending level dB relative to ARL	Sending Ratio (dB)
-35	17,5
-30	22,5
-20	30,7
-10	33,3
0	33,7
+7	31,7
+10	25,5

Limits for intermediate levels are found by drawing straight lines between the breaking points in the table on a linear (dB signal level) – linear (dB ratio) scale.

Compliance of the sending distortion shall be checked by the test described in annex C, clause C.4.1.

The gain variation relative to the gain for ARL shall remain within the limits given in table 6. For intermediate levels, the same limits for gain variation apply.

Table 6: Variation of gain with input level, sending

Sending level dB relative to ARL	Upper limit (dB)	Lower limit (dB)
13	0,5	-0,5
0	0,5	-0,5
-20	0,5	-0,5
-20	0,5	-2
-30	0,5	-2
-30	1	-
-40	1	-
-40	2	-
-45	2	-

Compliance of the gain variation in the sending direction shall be checked by the test described in annex C, clause C.5.1.

3.9.2 Receiving

The receiving part between the UPCMI and ERP shall meet the requirements in this clause at the nominal setting of the volume control.

The ratio of signal-to-total distortion power measured with the proper noise weighting (see table 4 of CCITT Recommendation G.223) shall be above the limits given in table 7 when the sound pressure at ERP is up to +10 dBPa. For sound pressures exceeding +10 dBPa at the ERP there is no distortion requirement.

Table 7: Limits for signal-to-total distortion ratio

Receiving level at the digital interface (dBm0)	Receiving Ratio (dB)
-45	17,5
-40	22,5
-30	30,5
-20	33,0
-10	33,5
-3	31,2
0	25,5

Limits for intermediate levels are found by drawing straight lines between the breaking points in the table on a linear (dB signal level) – linear (dB ratio) scale.

Compliance of the receiving distortion shall be checked by the test described in annex C, clause C.4.2.

The gain variation relative to the gain at an input level of –10 dBm0, shall be within the limits given in table 8. For intermediate levels, the same limits for gain variation apply. The requirement is valid for sound pressures up to +10 dBPa. For sound pressures exceeding +10 dBPa at the ERP there is no lower limit requirement.

Table 8: Variation of gain with input level, receiving

Receiving level at the digital interface (dBm0)	Upper limit (dB)	Lower limit (dB)
+3	0,5	-0,5
-10	0,5	-0,5
-40	0,5	-0,5
-40	1	-1
-50	1	-1
-50	2	-2

Compliance of the gain variation in the receiving direction shall be checked by the test described in annex C, clause C.5.2.

3.10 Sidetone (handset and headset MS)

3.10.1 Sidetone loss

A sidetone requirement is appropriate for MSs using handsets and headsets. There are separate requirements for listener sidetone (LSTR) and talker sidetone (STMR). The listener sidetone performance is considered as the major parameter affecting the user perception of the system. Though talker sidetone is important to give the user some comfort in using the equipment.

The value of the Listener Sidetone Rating (LSTR) shall not be less than 15 dB. Where a user-controlled receiving volume control is provided, the LSTR shall meet the requirement given above at the setting where the RLR is equal to the nominal value.

Compliance of the LSTR requirement shall be checked by the test described in annex C, clause C.6.2.

The nominal value of the Sidetone Masking Rating (STMR) shall be $13 \text{ dB} \pm 5 \text{ dB}$. Where a user-controlled receiving volume control is provided, the STMR shall meet the requirement given above at the setting where the RLR is equal to the nominal value.

Compliance of STMR requirement shall be checked by the test described in annex C, clause C.6.1.

It is recommended that the STMR is independent of the volume control.

3.10.2 Sidetone distortion

The third harmonic distortion generated by the terminal equipment shall not be greater than 10 %.

Compliance shall be checked by the test described in annex C, clause C.7.

3.11 Out-of-band signals

3.11.1 Discrimination against out-of-band input signals

3.11.1.1 Handset and headset MS

When out-of-band signals are applied at the MRP, a range of frequencies will be transmitted to the UPCMI. For these signals, the following requirements shall apply.

With any sine-wave signal above 4.6 kHz and up to 8 kHz applied at the MRP at a level of $-4,7 \text{ dBPa}$, the level of any image frequency produced at the digital interface shall be below a reference level obtained at 1 kHz ($-4,7 \text{ dBPa}$ at MRP) by at least the amount (in dB) specified in table 9.

Table 9: Discrimination levels

Applied sine-wave frequency	Limit (minimum) *
4,6 kHz	30 dB
8 kHz	40 dB
NOTE: *: The limit at intermediate frequencies lies on a straight line drawn between the given values on a log (frequency) – linear (dB) scale.	

Compliance shall be checked by the test described in annex C, clause C.8.1.

3.11.1.2 Handsfree MS

When out-of-band signals are applied at the MRP, a range of frequencies will be transmitted to the SS and input to the speech encoder. For the signals at the output of the speech encoder, the following requirements shall apply.

With a white Gaussian noise signal bandlimited to 4,6 kHz up to 8 kHz applied at the MRP at a level of -4,7 dBPa, the total power in the frequency band 300 Hz to 3,4 kHz measured after decoding the output of the speech encoder shall be below the reference level by at least 40 dB. This reference level is obtained by applying an ITU-T P.50 artificial speech signal bandlimited to 300 Hz and 3,4 kHz at a level of -4,7 dBPa at the MRP and measuring the average level of the signal at the speech encoder output after decoding it.

Compliance shall be checked by the test described in annex C, clause C.8.3.

3.11.2 Spurious out-of-band signals

3.11.2.1 Handset and headset MS

The level of out-of-band signals at the ERP shall meet the following requirements when the relevant input signals are simulated at the UPCMI.

With a digitally-simulated sine-wave signal in the frequency range of 300 Hz to 3,4 Hz and at a level of 0 dBm applied at the digital interface, the level of spurious out-of-band image signals in the frequency range of 4,6 to 8 kHz measured selectively at the ERP shall be lower than the in-band acoustic level produced by a digital signal at 1 kHz set at the level specified in table 10.

Table 10: Discrimination levels

Image Signal frequency	Equivalent Input Signal Level *
4,6 kHz	-35 dBm0
8 kHz	-45 dBm0
NOTE: *: The limit at intermediate frequencies lies on a straight line drawn between the given values on a log (frequency) – linear (dB) scale.	

Compliance shall be checked by the test described in annex C, clause C.8.2.

3.11.2.2 Handsfree MS

The level of out-of-band signals at the output of the HATS shall meet the following requirements when the relevant input signals are applied in the receive direction.

With an ITU-T P.50 artificial speech signal in the frequency range of 300 Hz to 3,4 Hz and at a level of -12 dBm0 applied in the receive direction, the level of spurious out-of-band image signals in the frequency range of 4,6 to 8 kHz measured at the ERP shall be below the reference level by at least 45 dB. This reference level is obtained by measuring the in-band acoustic reference level produced by the same input signal.

Compliance shall be checked by the test described in annex C, clause C.8.4.

3.12 Requirements for information tones

The PLMN should be capable of transmitting information tones generated by the PSTN conforming to I-ETS 300 245-7.

3.13 Crosstalk

3.13.1 Near and far end crosstalk

The near end or far end crosstalk ratio between two complete PLMN connections should not be less than 65 dB.

3.13.2 Go/return crosstalk

The crosstalk ratio between the go and return channels of a single PLMN connection should not be less than 55 dB. This is to avoid nullifying the effect of the electrical echo canceller at the MSC. The requirement applies for an acoustic input signal at the MRP with a measurement being made at the UPCMI in the opposite direction of transmission.

3.14 MS Ambient Noise Rejection

The nature of mobile telephony is such that the MS will typically be operated in high ambient acoustic noise. Due to the adverse interaction of noise signals with the TCH-FS and TCH-HS speech codecs, a minimum noise rejection specification is required.

3.14.1 Full-Rate, (TCH-FS) MS Ambient Noise Rejection (handset MS)

The MS ambient noise rejection, calculated as a Single Figure DELSM (SFDELSM) shall be greater than or equal to 0 dB. For good performance, it is recommended that a figure of +3 dB should be achieved.

Compliance shall be checked by the test described in annex C, clause C.11.

3.14.2 Full-Rate, (TCH-FS) MS Ambient Noise Rejection (handsfree MS)

[TBD]

3.14.3 Half-Rate, (TCH-HS) MS and Dual-Rate (TCH-FS and TCH-HS) MS Ambient Noise Rejection

[TBD]

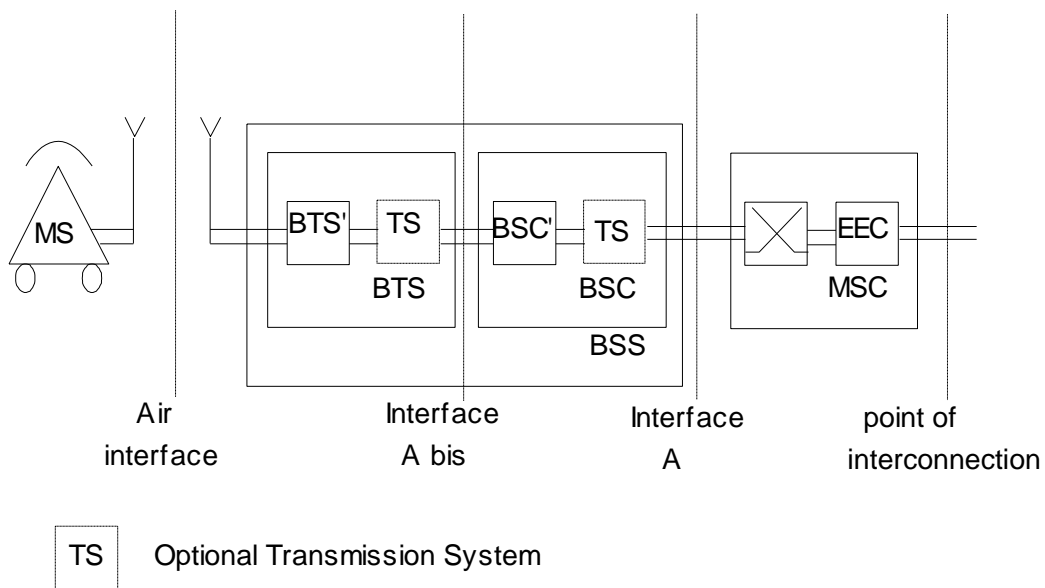

NOTE 1: For transmission planning purposes. Interfaces A and A bis are not required.

NOTE 2: The speech transcoder may be at either the BTS or the BSC.

Figure 1: Basic Configuration for Interworking with the PSTN

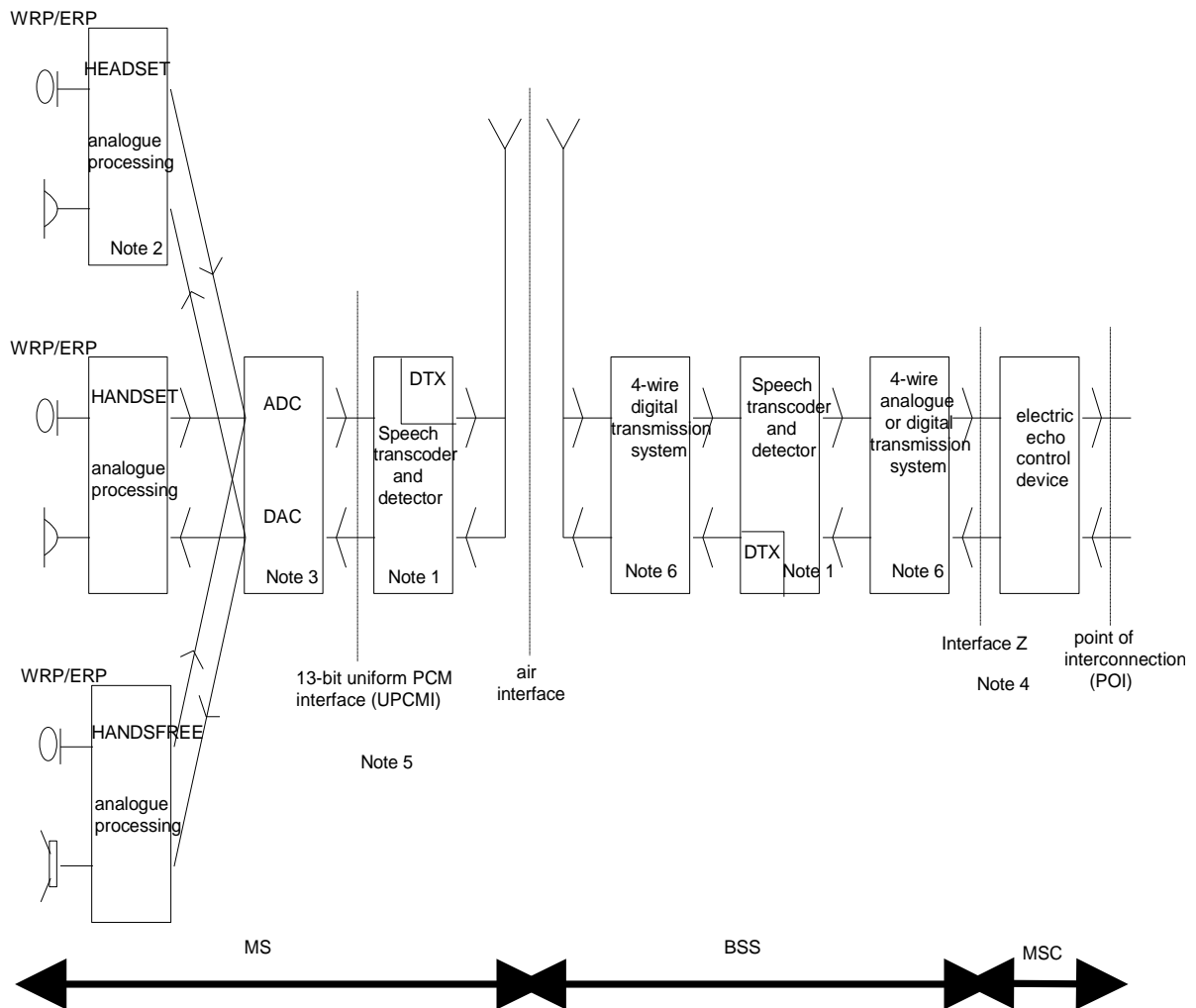

- NOTE 1: Speech detection is incorporated in the speech transcoder. Speech detection is needed to provide the function of DTX and, if required, acoustic echo control (see note 2).
- NOTE 2: Acoustic echo control may not be provided in the case of the headset.
- NOTE 3: Includes filtering.
- NOTE 4: In the case of direct MSC to MSC connections, the EEC function should not be active. The EEC device should be either disabled or not inserted in the circuit.
- NOTE 5: In single talk and in double talk, when no centre clipper is used, and in double talk only if a centre clipper is used, the level of quantizing noise introduced by the speech transcoding will effect the level of residual acoustic echo when echo cancellation techniques are used for AEC.
- NOTE 6: The transmission system need not be present.

Figure 2: PLMN System Model Used for Consideration of Transmission Planning Issues

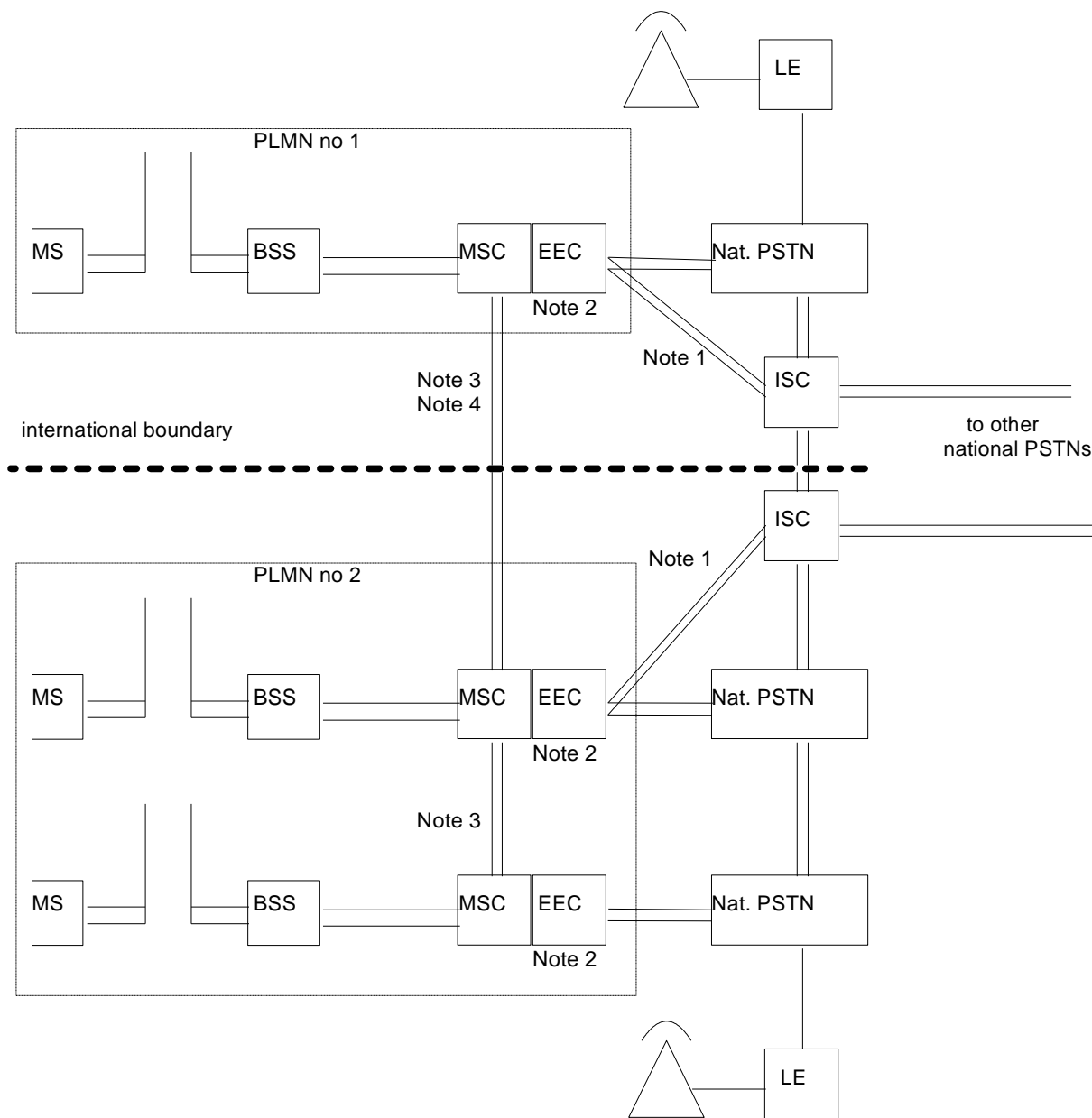

- NOTE 1: A direct link between MSC and ISC may be used in cases where Signalling System No. 7 is not provided in the PSTN or where a link via the PSTN would have excessive delay.
- NOTE 2: An echo canceller should be provided at every POI to cancel any echo returning to the PLMN from the PSTN. This is necessary because the one-way echo path back to the MS greatly exceeds 25 ms (see ITU-T Recommendation G.131).
- NOTE 3: A direct link between MSCs reduces the number of echo control devices that need to be provided and avoids the tandem connection of such devices. These direct links may be expected to have less delay than PSTN connections.
- NOTE 4: This arrangement may be provided.

Figure 3: PLMN to PSTN Interconnection Configurations

Direct routing and re-routing where the overall delay of the transmission path has not been extended and no echo control in the PSTN.

Normal configurations.

Call from PSTN to PLMN

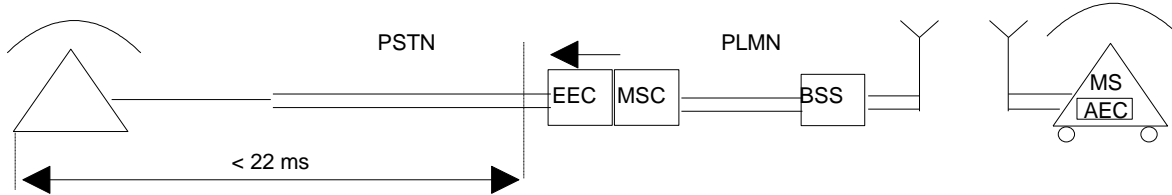

Call from PLMN to PSTN

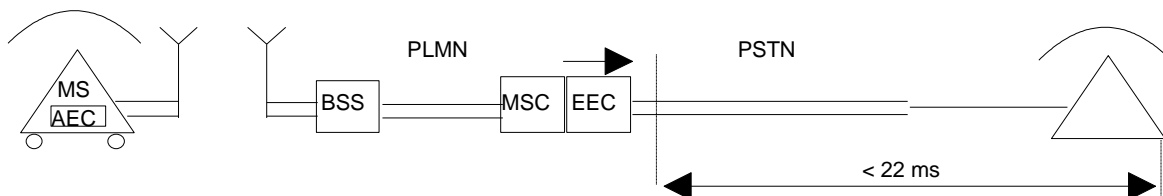

Call from PLMN to PLMN

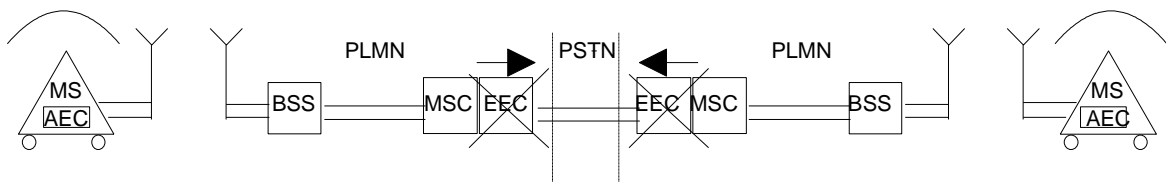

Call from PSTN to PLMN with re-route at MSC and via PSTN

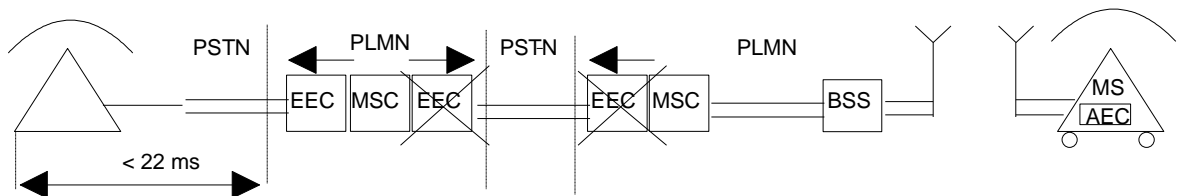

Direction of signalling is left to right

 echo control disabled

 direction of arrow indicates the echo loop

Other configurations may exist if a call from PLMN to PLMN is re-routed at an MSC via the PSTN

Figure 4: (continued) Reference Configurations A

Where direct MSC-MSC connections exist, these configurations may apply.

Call from PSTN to PLMN with re-route via PLMN

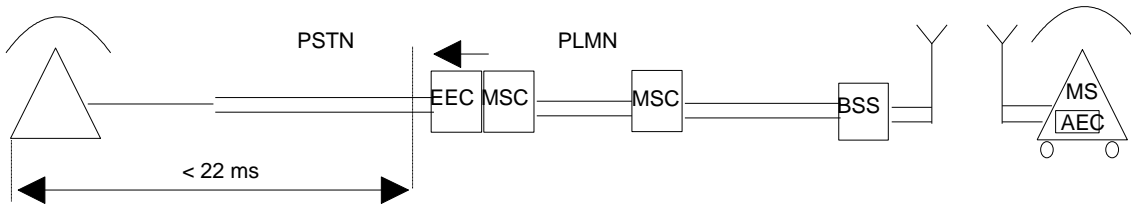

Call from PLMN to PSTN with long routeing in PLMN

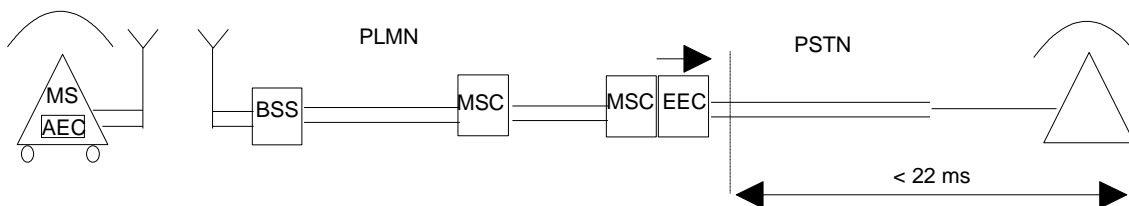

Call from PLMN to PLMN not involving PSTN

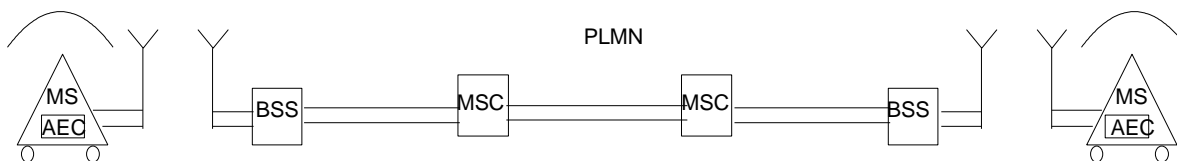

Direction of signalling is left to right

➔ direction of arrow indicates the echo loop

Figure 4: (concluded)

Direct routeing and re-routeings where the overall delay of the transmission path has not been extended and with echo control in the PSTN.

Normal configurations.

Call from PSTN to PLMN

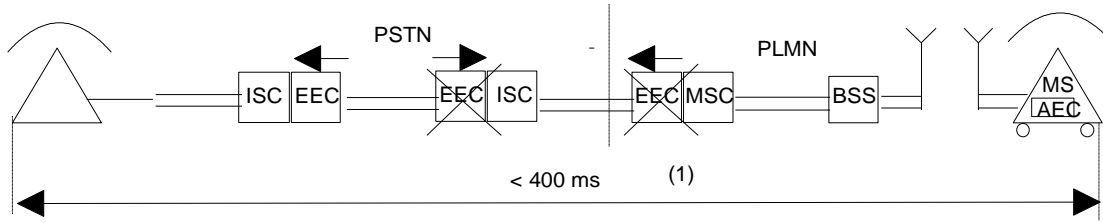

Call from PLMN to PSTN

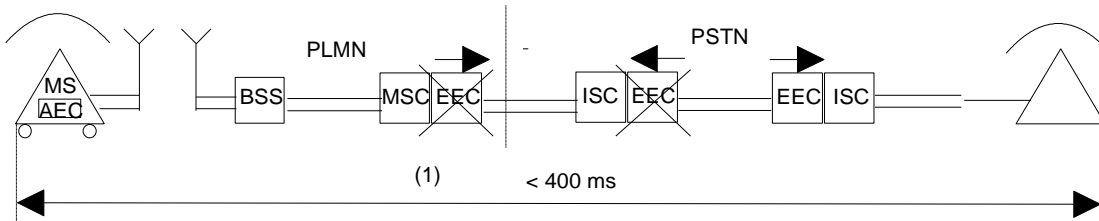

Call from PLMN to PLMN

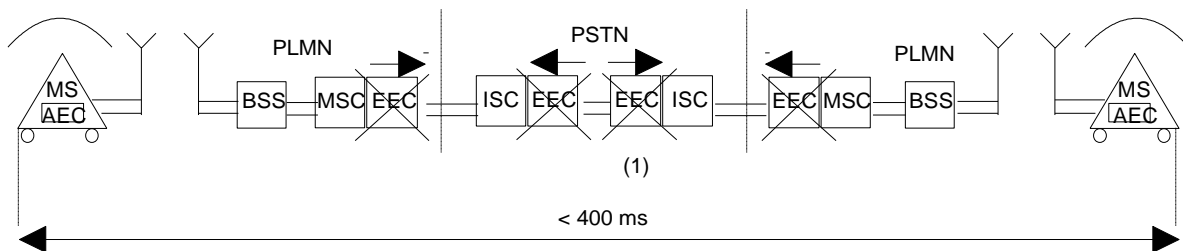

(1) see subclause 3.3.5.2

Direction of signalling is left to right

- echo control disabled
- direction of arrow indicates the echo loop

Other configurations may exist if a call from PLMN to PLMN is re-routed at an MSC via the PSTN

Figure 5: (continued) Reference Configurations B

Where direct MSC – MSC connections exist, these configurations may apply.

Call from PSTN to PLMN with re-route via PLMN

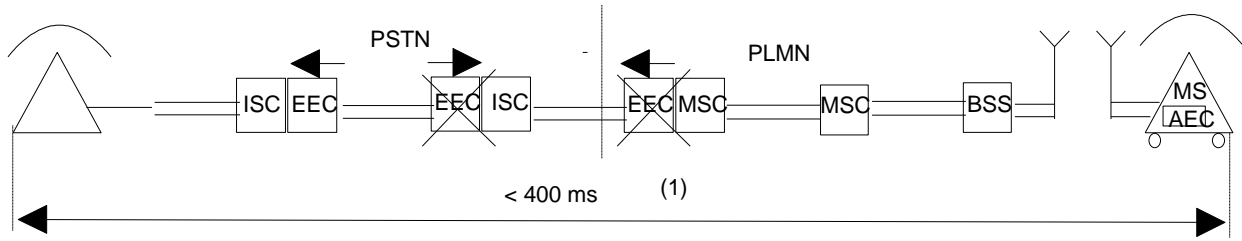

Call from PLMN to PSTN with long routing in PLMN

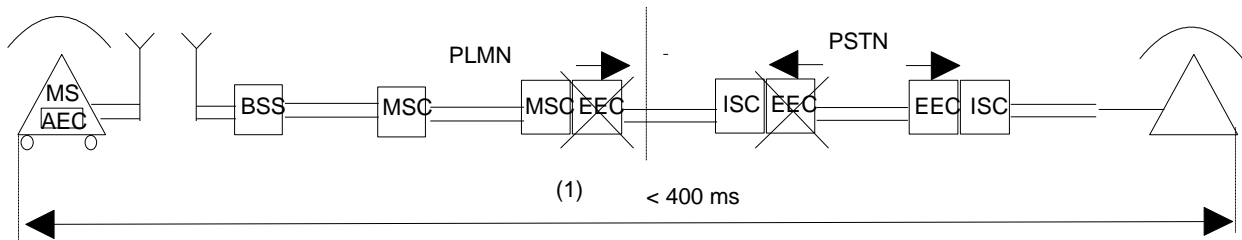

(1) see subclause 3.3.5.2

Direction of signalling is left to right



-  echo control disabled
-  direction of arrow indicates the echo loop

Figure 5: (concluded)

Re-routings where the overall delay of the transmission path has been extended beyond transmission planning limits.

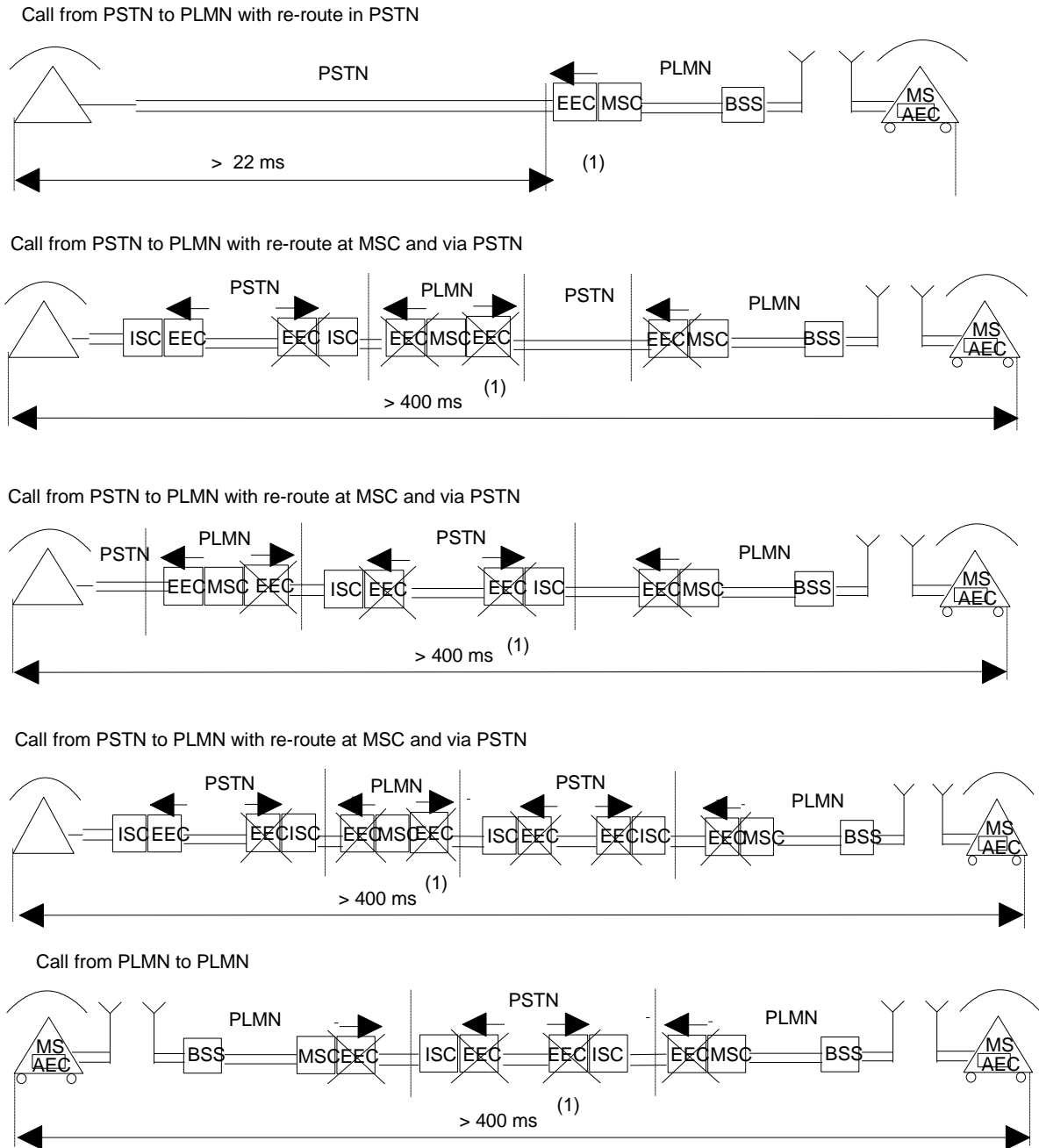

(1) see subclause 3.3.5.2

Direction of signalling is left to right

echo control disabled

direction of arrow indicates the echo loop

Other configurations may exist if a call from PLMN to PLMN is re-routed at an MSC via the PSTN

Figure 6: Reference Configuration C

No echo control in PSTN.

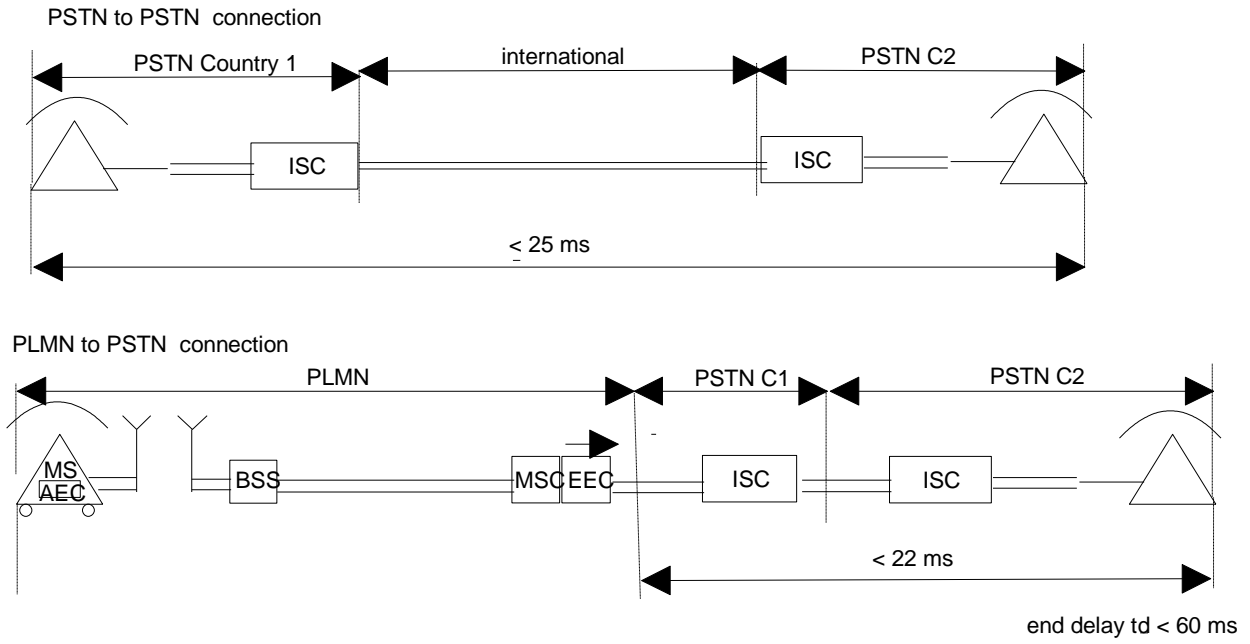

Echo control in PSTN.

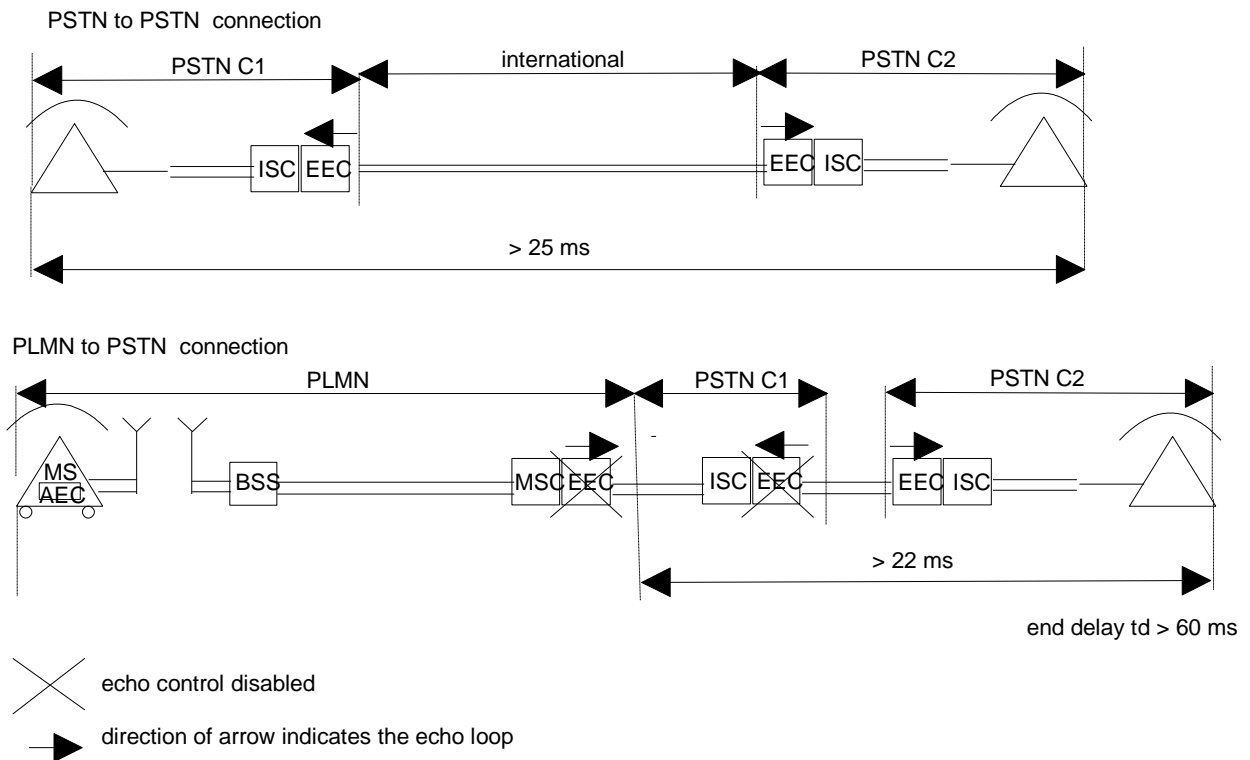

Figure 7: End Delay Requirements for PLMN EEC

Annex A (informative): Considerations on the Acoustic Interface of the Mobile Station

A.1 Handsfree MS

The handsfree MS will almost certainly require the use of non-linear processing for the acoustic echo control, the extraction of the speech from high levels of ambient noise. The implementation of these functions may well cause degradation to the overall transmission quality and cause difficulty to the distant end user especially during duplex conversation.

A.2 Handset MS

The handset MS, depending on the detailed implementation, might not require the use of non-linear processing for the acoustic echo control. Also, the position of the microphone should give a significantly improved signal-to-noise ratio, compared with a handsfree MS especially in noisy environments. This is likely to result in significantly improved transmission quality compared with the handsfree MS and easier duplex conversation.

A.3 Headset MS

The headset MS is likely to be the simplest, since with careful design, it might not require acoustic echo control. As with the handset case, the signal-to-noise ratio should be significantly improved compared with the handsfree MS especially in noisy environments. Consequently, the headset MS is likely to give the best transmission quality and easiest duplex conversation.

A.4 Inter-reaction with DTX

Because of the improved signal-to-noise ratio, both the headset MS and the handset MS are likely to give better transmission quality when DTX is enabled than that of handsfree MS.

Annex B (normative): Test considerations

B.1 Test signals

B.1.1 Sinusoidal signals

Unless specified otherwise, sinusoidal signals shall be used for testing the characteristics of the handset and headset MS.

B.1.2 Artificial voice

Unless specified otherwise, artificial voice shall be used for testing all the characteristics of the handsfree MS, and acoustic echo loss and stability loss of handset and headset MSs.

The artificial voice shall be in conformance with ITU-T Recommendation P.50, and shall cover the fourteen 1/3 octave bands with a centre frequency between 200 Hz and 4 kHz or the 1/12 octave bands with a centre frequency between 200 Hz and 4 kHz. Outside these bandwidths the signal shall be filtered with a minimum slope of 24 dB/octave.

A "male" and a "female" artificial voice shall be used.

The artificial voice signal level shall be averaged over a period of 10 seconds. Unless specified otherwise, the averaging time for all the tests shall be 10 seconds.

B.2 Test signal levels

B.2.1 Sending

B.2.1.1 Handset and headset MSs

For the tests of Handset and headset MS, unless specified otherwise, the test signal level shall be $-4,7$ dBPa at the MRP.

B.2.1.2 Office type Handsfree MS

For the office type handsfree the test signal level shall be $-28,7$ dBPa at the HFRP. The characteristics of the artificial mouth shall be in conformance with ITU-T Recommendation P.51.

Calibration of the artificial mouth

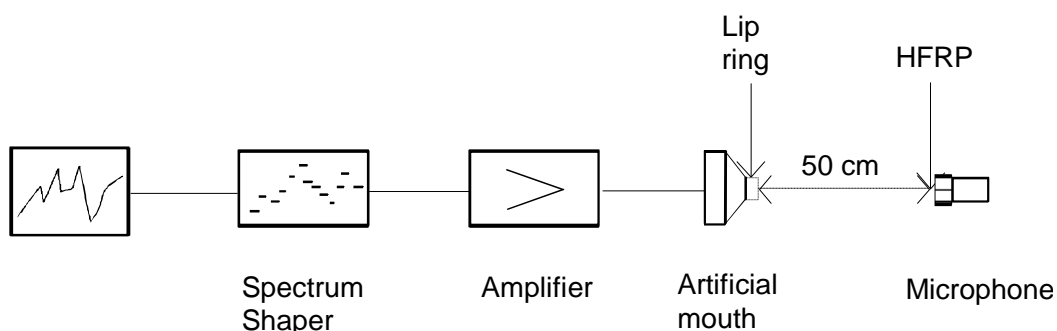

Figure 8

To perform the calibration of the artificial mouth, the following procedure shall be used:

- the input signal from the artificial mouth is first calibrated under free field conditions at the MRP (the total level in the frequency range corresponding to the third octave bands from 200 Hz to 4000 Hz is set to $-4,7$ dBPa);
- then the level is adjusted to $-28,7$ dBPa at the HFRP. The spectrum is not altered. The actual level at the MRP (measured in third octaves) is used as reference for calculating SLR.

NOTE: The HFRP corresponds to the measurement point 11 of ITU-T Recommendation P.51 [13]. The transfer function between HFRP and MRP amounts to $24,0$ dB + $3/-4$ dB.

B.2.1.3 Car type Handsfree MS

For the car type handsfree MS the test signal level shall be $-28,7$ dBPa at the HFRP. The characteristics of the artificial mouth of the HATS shall be in conformance with ITU-T Recommendation P.58.

Calibration of the artificial mouth of the HATS

To perform the calibration of the artificial mouth of the HATS, the following procedure shall be used:

- the input signal from the artificial mouth is first calibrated under free field conditions at the MRP (the total level in the frequency range corresponding to the third octave bands from 200 Hz to 4 000 Hz is set to $-4,7$ dBPa). The spectrum at MRP is recorded;
- then the level is adjusted to $-28,7$ dBPa at the HATSHFRP. The actual level at the MRP (measured in third octaves) is used as the reference for sending characteristics;
- The test set up shall be in conformance with the figure 8, but the HFRP replaced by the appropriate HATSHFRP defined as follows:
 - the HATSHFRP corresponds to a reference point "n" from ITU-T Recommendation P.58: "n" shall be one of the points numbered from 11 to 17 and defined in table 6a/P.58 (co-ordinates of far field front point). The HATSHFRP depends on the location(s) of the microphones in the car: the appropriate axis lip-ring/HATSHFRP shall be as close as possible to the axis lip-ring/HFT microphone.

NOTE: As an example, if the manufacturer indicates that the handsfree microphone should be located in front of the HATS, but with an elevation angle of 40° from the horizontal plane, the HATSHFRP shall be chosen as point 13 (table 6a/P58). In such a case the transfer function between HATSHFRP and MRP amounts to $25,0$ dB + $3/-4$ dB in the third octave bands centred on 200 Hz;
 24 dB + 3 dB in the octave bands centred on 250 Hz, 315 Hz, 400 Hz, 500 Hz and 2 kHz;
 24 dB + $3/-4$ dB in the octave bands centred on 1 250 Hz and 1 600 Hz;
 $25,5$ dB + $3/-4$ dB in the octave bands centred on 630 Hz and 1 kHz; and
 27 dB + $3/-4$ in the octave band centred on 800 Hz.

B.2.2 Receiving

Unless specified otherwise, the applied test signal level at the digital input shall be -16 dBm₀, and the user-controlled receiving volume control set to the position at which RLR is met.

B.3 Test rooms

B.3.1 Anechoic room

For the repeatability of the tests, the environment for the measurement of the office type handsfree shall be free field (anechoic) down to the lowest frequency of the 1/3 octave band centred on 200 Hz.

Satisfactory free field conditions exist where errors, due to the departure from ideal conditions, do not exceed ± 1 dB, inside a sphere centred on point B (see figure 3 of ITU-T Recommendation P.34 [11]), with a 1 m radius, in the absence of the table (see note 3 as a provisional method for controlling these conditions).

The broadband noise level shall not exceed -70 dBPa(A). The octave band noise level shall not exceed the values specified in table A.1.

Table A.1: Noise level

Centre frequency (Hz)	Octave band pressure level (dBPa)
63	-45
125	-60
250	-65
500	-65
1 k	-65
2 k	-65
4 k	-65
8 k	-65

NOTE 1: For TCL tests and echo cancelling characteristics, it could be useful to define a standardized test room. For further study.

NOTE 2: The ambient noise in the test room for the adaptive gain control testing is under study.

NOTE 3: A room including the test arrangement fulfilling the following requirements probably meets the satisfactory conditions.

Dimensions of the room: height $\geq 2,2$ m ; volume $V \geq 30$ m³.

The table should be placed horizontally in the centre of the test room and there should be an inclination of $\sim 30^\circ$ between the table and the ceiling.

The reverberation time T, measured at points B and C, should satisfy the following inequality: $T(s) \leq 0,0033 V$ (m³); which is based on a calculation with the radius of 50 centimetres.

B.4 Test arrangement

B.4.1 Electro-acoustic equipment

Artificial mouth: unless specified otherwise, the artificial mouth shall conform to ITU-T Recommendation P.51 [38].

Artificial ear: the ITU-T Recommendation P.57 [46] Type 1 shall be used.

If requested by the terminal supplier, the ITU-T Recommendation P.57 [46] Type 3.2 artificial ear shall be used for all tests. In this case the following apply:

- the low leakage option of Type 3.2 artificial ear shall be adopted;
- the force against the ear shall be as specified in ITU-T Recommendation P.57 [46];
- sound pressure measurements shall be referred to the ERP as specified in ITU-T Recommendation P.57 [46];
- no leakage correction shall be made in the calculation of RLR (i.e. $L_E=0$).

If requested by the terminal supplier, the ITU-T Recommendation P.57 [46] Type 3.4 artificial ear may be used. The positioning is defined in ITU-T Recommendation P.64.

The test report shall indicate the type of artificial ear used for the receive tests.

HATS: when a HATS is used, it shall conform to ITU-T Recommendation P.58. In such a case, all the sending and receiving characteristics shall be tested with the HATS and it shall be indicated in the test report that the HATS was used.

B.4.2 Test arrangement for handsfree MS

B.4.2.1 Office type handsfree MS

The handsfree terminal is placed on a table according to ITU-T Recommendation P.34 (clause 6.1: test table; clause 6.2: test arrangements and figure 3 of ITU-T Recommendation P.34).

The artificial mouth axis and the microphone axis are coincident with the straight line drawn between point C and point B (see figure 9).

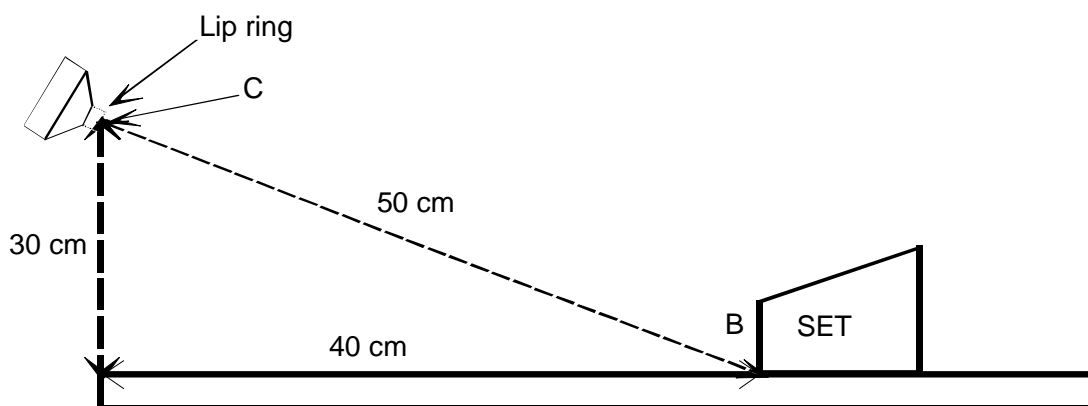

Figure 9: Measurement configuration

In case of two or more piece hands-free MS, care shall be taken to ensure that the test arrangement does not modify the normal use of the hands-free MS.

B.4.2.2 Car type handsfree MS

The hands-free set is positioned in the car as specified by the manufacturer.

The HATS is placed inside the car as shown in figure 10. The lipring of the HATS is adjusted parallel to a plane defined by two parallel points defining a line 90 degrees to the driving direction inside the car (e.g. A-pillar) and perpendicular.

The manufacturer needs to define unambiguously the exact position of the Ear Canal Entrance point (EEP) relative to fixed positions inside the car, e.g. distance to the roof and distance to the upper edge of the windscreen.

Unless specified otherwise by the manufacturer, the distance between hands-free MS-microphone and lipring shall be as specified in figure 10.

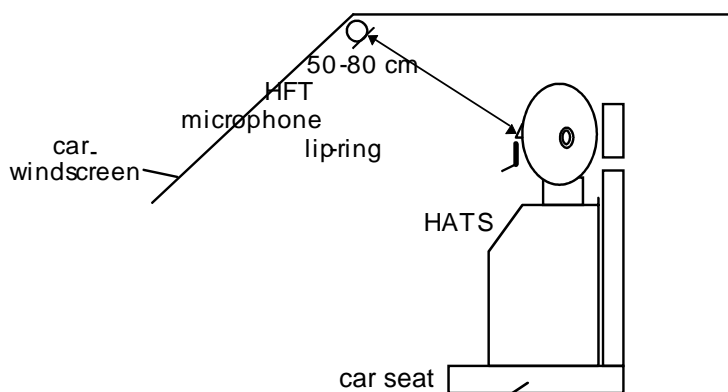

Figure 10: Measurement configuration for car type applications

B.4.2.3 Use of HATS for testing the receive characteristics of the car type handsfree MS

B.4.2.3.1 Equalization of HATS

Due to the diffractions and reflections of torso, shoulder, head and pinna the HATS behaves differently from an ordinary measurement microphone. The transfer functions are directional and not flat. The typical head transfer function for different directions can be found in ITU-T Recommendation P.58 [1]. Since the characteristics of the artificial head are directional, a reference position must be found which gives comparable results to those obtained with an ordinary measurement microphone. For this reference position the HATS is equalized in such a way, that the measured frequency response is flat (like a standard measurement microphone). A suitable reference position is 0 degrees. In front of the HATS, anechoic condition. The equalization for this reference condition is known as "free field equalization".

For the measurement a HATS complying with the free-field and diffuse field reception characteristic as described in ITU-T Recommendation P.58 is used. This head is either a free-field equalized HATS or the test set-up as described in the following needs to be used.

The equalization is made for this reference position in an anechoic chamber (see figure 11). The minimum distance of the reference sound source is 1,5 m.

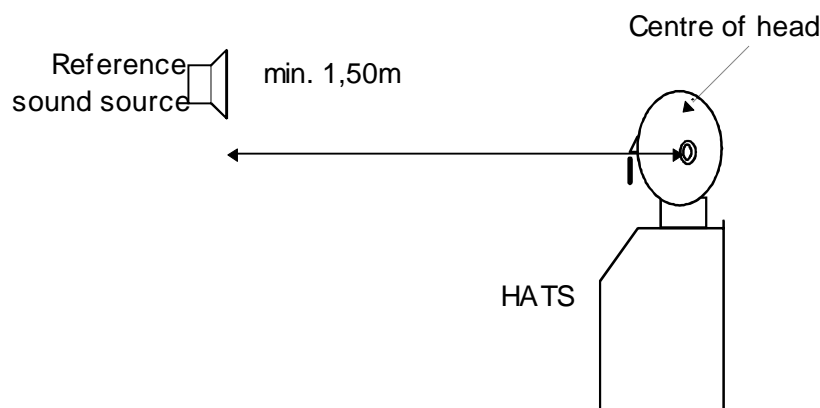

Figure 11: Set-up for HATS free field calibration in an anechoic chamber

The measured free-field response of the HATS is:

$$H_{ff}(0^\circ, 0^\circ, f)$$

From this the free-field equalization is calculated:

$$H_{EQ}(0^\circ, 0^\circ, f) = 1 / H_{ff}(0^\circ, 0^\circ, f)$$

The equalization must be correct within $\pm 0,5$ dB within the frequency range from 100 Hz to 8 kHz measured in 1/3rd octaves.

NOTE: The free-field equalization of a HATS requires a very careful set-up of the measurement. Due to the strong directivity of the HATS small deviations from the reference position ($0^\circ, 0^\circ$) may cause wrong equalizer transfer functions.

The HATS set-up for the measurements then is as follows.

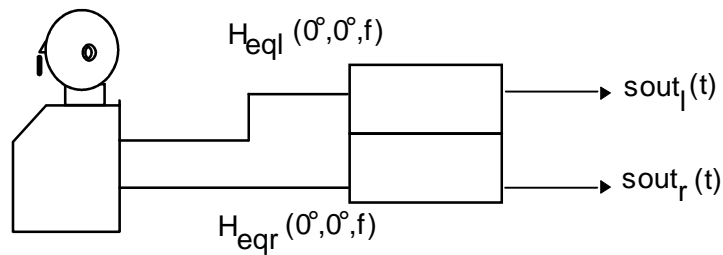

Figure 12: Measurement set-up for HATS ($H_{eq_l}(0^\circ, 0^\circ, f)$ = free-field equalizer left ear, $H_{eq_r}(0^\circ, 0^\circ, f)$ = free-field equalizer right ear)

B.4.2.3.2 Combination of ear signals

The signals from the two ear microphones of HATS are combined as follows:

- the output signal of each channel is averaged in power for the complete time of the analysis;
- the power density spectra received by this averaging are added for each frequency;
- the sum of signals achieved by this procedure will be treated as the input signal for all further calculations such as frequency response measurements, loudness rating calculation etc. as defined in ITU-T Recommendation P.34.

For receiving loudness rating calculations the hands-free factor HFL_E replaces the L_E factor used in the algorithm P.79:

- $HFL_E = 6$ dB.

NOTE 1: The summing of the two ear signals of the HATS as described above leads to a level increase of about 6 dB under ideal conditions. This reflects the difference of loudness perceived subjectively when listening monaural (one ear listening) compared to binaural listening.

NOTE 2: The additional correction of 6 dB takes into account the different preferred listening levels for hands-free MS's in comparison to handset listening. The diffraction effect of the HATS is produced by the HATS itself. So this effect, described in ITU-T Recommendation P.34 is not taken into account for HATS measurements.

Annex C (normative): Transmission requirements testing

C.1 Loudness ratings

C.1.1 Sending Loudness Rating (SLR) – Handset MS

When measured at the DAI:

- the sending sensitivity shall be measured at each of the 14 frequencies given in table 1 of ITU-T Recommendation P.79, bands 4 – 17;
- the sensitivity is expressed in terms of dBV/Pa and the SLR shall be calculated according to ITU-T Recommendation P.79 formula 2.1, over bands 4 to 17, and using $m = 0,175$ and the sending weighting factors from ITU-T Recommendation P.79 table 1.

Measured at the output of the reference speech decoder of the SS:

- the sending sensitivity from the MRP to the digital output of the reference speech decoder of the SS is determined according to C.3.1;
- the sensitivity is expressed in terms of dBV/Pa and the SLR shall be calculated according to ITU-T Recommendation P.79 formula 2.1, over bands 4 to 17, and using $m = 0,175$ and the sending weighting factors from ITU-T Recommendation P.79 table 1.

C.1.2 Sending Loudness Rating (SLR) – Handsfree MS

- The sending sensitivity from the MRP to the digital output of the reference speech decoder of the SS is determined according to C.3.2.
- The sensitivity is expressed in terms of dBV/Pa and the SLR shall be calculated according to ITU-T Recommendation P.79 formula 2.1 over bands 4 to 17. The sending weighting factors are given in table 1 of ITU-T Recommendation P.79 and adjusted according to clause 3 of the same recommendation.

C.1.3 Receiving Loudness Rating (RLR) – Handset MS

When measured from the DAI:

- the receiving sensitivity shall be measured at each of the 14 frequencies listed in table 1 of ITU-T Recommendation P.79, bands 4 – 17;
- the sensitivity is expressed in terms of dBPa/V and the RLR shall be calculated according to ITU-T Recommendation P.79 formula 2.1, over bands 4 to 17, using $m = 0,175$ and the receiving weighting factors from table 1 of ITU-T Recommendation P.79;
- the artificial ear sensitivity shall be corrected by the L_E factor given in table 2 of ITU-T Recommendation P.79.

Measured from the input of the reference speech encoder of the SS:

- the receiving sensitivity from the analogue or digital input of the reference speech encoder of the SS to the output of the artificial ear is determined according to C.3.3;
- the sensitivity is expressed in terms of dBPa/V and the RLR shall be calculated according to ITU-T Recommendation P.79 formula 2.1, over bands 4 to 17, using $m = 0,175$ and the receiving weighting factors from table 1 of ITU-T Recommendation P.79.

C.1.4 Receiving Loudness Rating (RLR) - Handsfree MS

- The receiving sensitivity from the analogue or digital input of the reference speech encoder of the SS to the output of the measuring microphone (ITU-T Recommendation P.34; 6.2) or the output of the HATS is determined according to annex C, clause C.3.4. The signals from the two ears of the HATS are combined according to annex B, clause B.4.2.3.2.
- The sensitivity is expressed in terms of dBPa/V and the RLR shall be calculated according to ITU-T Recommendation P.79 formula 4.19c over bands 4 to 17. The final result is adjusted according to table 3 of the same recommendation to allow for the reduced bandwidth.
- The receiving sensitivity when using the HATS is corrected by 6 dB according to annex B, clause B.4.2.3.2 or when using the measuring microphone it is corrected according to ITU-T Recommendation P.34.

C.2 Idle Channel Noise

C.2.1 Sending

With the handset mounted at LRGP and the earpiece sealed to the knife-edge of the artificial ear in a quiet environment (ambient noise less than 30 dBA), the noise level at the digital output is measured with apparatus including psophometric weighting according to ITU-T Recommendation G.223, table 4.

NOTE: The ambient noise criterion should be met if the ambient noise does not exceed NR20.

C.2.2 Receiving

The handset is mounted at LRGP and the earpiece is sealed to the knife-edge of the artificial ear. A signal corresponding to decoder output value number 1 shall be applied at the digital interface. The level of the noise shall be measured at the ERP.

The ambient noise for this measurement shall not exceed 30 dBA.

C.3 Sensitivity/frequency characteristics

C.3.1 Sending - Handset MS

When measured at the DAI:

- the handset is mounted in the LRGP (see annex A of ITU-T Recommendation P.76). The earpiece is sealed to the knife-edge at the ERP;
- a pure tone signal with a sound level of $-4,7$ dBPa (in accordance with ITU-T Recommendation P.64 shall be applied at the MRP as described in ITU-T Recommendation P.64, using an artificial mouth conforming to ITU-T Recommendation P.51;
- a digital measuring instrument, or high quality digital decoder followed by an analogue level measuring set, shall be connected at the interface;
- measurements shall be made at one twelfth-octave intervals as given by the R.40 series of preferred numbers in ISO 3 for frequencies from 100 Hz to 4 kHz inclusive.

At each frequency, the output level for a sound pressure of $-4,7$ dBPa shall be measured.

Measured at the output of the reference speech decoder of the SS:

- the handset is mounted in the LRGP and the earpiece is sealed to the knife-edge of an artificial ear;

- a speech call is set up between the MS and the SS;
- artificial speech conforming to ITU-T Recommendation P.50, shall be applied to the MRP, at a wideband sound pressure level of $-4,7$ dBPa. This implementation could be a real time algorithm producing the artificial speech or a pre-recorded tape of the artificial speech;
- the artificial speech shall comprise of a concatenation of three 10 s intervals of "male" and "female" voice. The first 10 s interval is not used for measurement purposes but allows any noise/echo cancelling devices in the MS to adapt. The second and third 10 s intervals consist of separately "male" and "female" artificial voice;
- the 1/3 octave filtered long-term average spectrum of the signal is measured at the digital output of the reference speech decoder of the SS and an average for the "male" and "female" voices obtained;
- the difference between the 1/3 octave input power and the 1/3 octave output power shall conform to the mask specified in clause 3.8.1.1.

C.3.2 Sending – Handsfree MS

- The handsfree MS is mounted as specified by the manufacturer and tested according to annex B clauses B.4.2.1 or B.4.2.2.
- A speech call is set up between the MS and the SS.
- Artificial speech conforming to ITU-T Recommendation P.50, bandlimited to 200 Hz and 4 kHz shall be applied to the MRP of the test fixture, at a wideband sound pressure level of $-4,7$ dBPa. This implementation could be a real time algorithm producing the artificial speech or a pre-recorded tape of the artificial speech.
- The artificial speech shall comprise of a concatenation of three 10 s intervals of "male" and "female" voice. The first 10 s interval is not used for measurement purposes but allows any noise/echo cancelling devices in the MS to adapt. The second and third 10 s intervals consist of separately "male" and "female" artificial voice.
- The 1/3 octave filtered long-term average spectrum of the signal is measured at the digital output of the reference speech decoder of the SS and an average for the "male" and "female" voices obtained.
- The difference between the 1/3 octave input power and the 1/3 octave output power shall conform to the mask specified in clause 3.8.2.1.

C.3.3 Receiving - Handset

When measured from the DAI:

- the handset is mounted in the LRGP and the earpiece is sealed to the knife -edge of the artificial ear;
- a digital signal generator shall be connected at the digital interface delivering a signal equivalent to a pure tone level of -16 dBm0, see ITU-T Recommendation P.64;
- measurements shall be made at one twelfth-octave intervals as given by the R.40 series of preferred numbers in ISO 3 for frequencies from 100 Hz to 4 kHz inclusive.

At each frequency, the sound pressure at the ERP shall be measured by connecting a suitable measuring set to the artificial ear.

Measured from the input of the reference speech encoder of the SS:

- the handset is mounted in the LRGP and the earpiece is sealed to the knife -edge of the artificial ear;
- a speech call is set up between the MS and the SS;
- artificial speech conforming to ITU-T Recommendation P.50, shall be applied to the analogue or digital input of the reference speech encoder of the SS, at a wideband level of -16 dBm0. This implementation could be a real time algorithm producing the artificial speech or a pre-recorded tape of the artificial speech;

- the artificial speech shall comprise of a concatenation of three 10 s intervals of "male" and "female" voice. The first 10 s interval is not used for measurement purposes but allows any echo cancellation devices in the MS to adapt. The second and third 10 s intervals consist of separately "male" and "female" artificial voice;
- the 1/3 octave filtered long-term average spectrum of the signal is measured and an average for the "male" and "female" voices obtained;
- the difference between the 1/3 octave input power and the 1/3 octave output power shall conform to the mask specified in clause 3.8.1.2.

C.3.4 Receiving - Handsfree

- The handsfree MS is mounted as specified by the manufacturer and tested according to clauses B.4.2.1 or B.4.2.2, annex B.
- A speech call is set up between the MS and the SS.
- Artificial speech conforming to ITU-T Recommendation P.50, bandlimited to 200 Hz and 4 kHz shall be applied to the analogue or digital input of the reference speech encoder of the SS, at a wideband level of -16 dBm0. This implementation could be a real time algorithm producing the artificial speech or a pre-recorded tape of the artificial speech.
- The artificial speech shall comprise of a concatenation of three 10 s intervals of "male" and "female" voice. The first 10 s interval is not used for measurement purposes but allows any echo cancellation devices in the MS to adapt. The second and third 10 s intervals consist of separately "male" and "female" artificial voice.
- The 1/3 octave filtered long-term average spectrum of the signal is measured at the ERP and an average for the "male" and "female" voices obtained.
- The difference between the 1/3 octave input power and the 1/3 octave output power shall conform to the mask specified in clause 3.8.2.2.

C.4 Distortion

C.4.1 Sending

The handset is mounted at LRGP and the earpiece is sealed to the knife-edge of the artificial ear.

A sine-wave signal with a frequency in the range 1 004 Hz to 1 025 Hz is applied at the MRP.

The level of this signal is adjusted until the output of the terminal is -10 dBm0. The level of the signal at the MRP is then the ARL.

The test signal shall be applied at the following levels: -35, -30, -25, -20, -15, -10, -5, 0, 5, 10 dB relative to ARL.

The ratio of the signal to total distortion power of the digital signal output shall be measured with the psophometric noise weighting (see ITU-T Recommendations G.712 and 0.132).

C.4.2 Receiving

The handset is mounted at LRGP and the earpiece is sealed to the knife-edge of the artificial ear.

A digitally simulated sine-wave signal with a frequency in the range 1 004 Hz to 1 025 Hz shall be applied at the digital interface at the following levels: -45, -40, -35, -30, -25, -20, -15, -10, -5, 0 dBm0.

The ratio of the signal-to-total distortion power shall be measured with the psophometric noise weighting at the ERP (see ITU-T Recommendations G.712 and 0.132).

C.5 Variation of gain with input level

C.5.1 Sending

The handset is mounted at LRGP and the earpiece is sealed to the knife-edge of the artificial ear.

A sine-wave signal with a frequency in the range 1 004 Hz to 1 025 Hz is applied at the MRP. The level of this signal is adjusted until the output of the terminal is -10 dBm0. The level of the signal at the MRP is then the ARL.

The test signal shall be applied at the following levels: -45 , -40 , -35 , -30 , -25 , -20 , -15 , -10 , -5 , 0 , 5 , 10 , 13 dB relative to ARL.

The variation of gain relative to the gain for ARL is measured.

NOTE: Selective measurement may be used to avoid the effects of ambient noise.

C.5.2 Receiving

The handset is mounted at LRGP and the earpiece is sealed to the knife-edge of the artificial ear.

A digitally simulated sine-wave signal with a frequency in the range 1 004 Hz to 1 025 Hz shall be applied at the digital interface at the following levels: -50 , -45 , -40 , -35 , -30 , -25 , -20 , -15 , -10 , -5 , 0 , 3 dBm0.

The variation of gain relative to the gain at an input level of -10 dBm0 shall be measured at the ERP.

NOTE: Selective measurement may be used to avoid the effects of ambient noise.

C.6 Sidetone

For the tests described in clauses C.6.1 and C.6.2, annex C, the digital input of the terminal shall be driven by a PCM signal corresponding to decoder value number 1.

C.6.1 Talker sidetone (STMR)

- The handset is mounted in the LRGP and the earpiece is sealed to the knife-edge of the artificial ear. A pure tone signal of $-4,7$ dBPa shall be applied at the mouth reference point. For each frequency given in ITU-T Recommendation P.79 table 3, bands 1 to 20, the sound pressure (ERP) shall be measured.
- The sidetone path loss L_{meST} as expressed in dB and the STMR (in dB) shall be calculated from the formula 2.1 of ITU-T Recommendation P.79, using $m = 0,225$ and the weighting factors in table 3 of ITU-T Recommendation P.79.

C.6.2 Listener sidetone (LSTR)

- The sound field is calibrated in the absence of any local obstacles. The averaged field shall be uniform to within $+4$ dB/ -2 dB within a radius of $0,15$ m of the MRP, when measured in one-third octave bands from 100 Hz to 8 kHz (bands 1 to 20).
- A calibrated half-inch microphone is mounted at MRP. The sound field is measured in one-third octave bands. The spectrum shall be "Pink noise" as described in ITU-T recommendation P.64 annex C to within ± 1 dB and the level shall be adjusted to 70 dBA (-24 dBPa(A)). The tolerance on this level is ± 1 dB.
- The artificial mouth and ear are placed in the correct position relative to MRP, the handset is mounted at LRGP and the earpiece is sealed to the knife-edge of the artificial ear.

- Measurements are made in one-third octave bands for the 20 bands centred at 100 Hz to 8 kHz (bands 1 to 20). For each band the sound pressure at the ERP shall be measured by connecting a suitable measuring set to the artificial ear.
- The listener sidetone path loss is expressed in dB and the LSTR shall be calculated from the ITU-T Recommendation P.79 formula 2.1, using $m = 0,225$ and the weighting factors in table 3 of the Recommendation.

C.7 Sidetone distortion

The handset is mounted at LRGP and the earpiece is sealed to the knife-edge of the artificial ear. An instrument capable of measuring the third harmonic distortion of signals with fundamental frequencies in the range of 315 Hz to 1 kHz is connected to the artificial ear.

A pure-tone signal of $-4,7$ dBPa is applied at the mouth reference point at frequencies of 315 Hz, 500 Hz, and 1 kHz. For each frequency, the third harmonic distortion shall be measured at the ERP.

C.8 Out-of-band signals

C.8.1 Discrimination against out-of-band input signal for handset and headset MS

The handset is mounted at LRGP and the earpiece is sealed to the knife-edge of the artificial ear.

For input signals at frequencies of 4,65 kHz, 5 kHz, 6 kHz, 6,5 kHz, 7 kHz and 7,5 kHz at the level specified in clause 3.11.1, the level of any image frequencies at the digital interface shall be measured.

C.8.2 Spurious out-of-band signals for handset and headset MS

The handset is mounted at LRGP and the earpiece is sealed to the knife-edge of the artificial ear.

For input signals at the frequencies 500, 1 000, 2 000, and 3 150 Hz applied at the level specified in clause 3.11.2, the level of spurious out-of-band image signals at frequencies of up to 8 kHz shall be measured selectively at the ERP.

C.8.3 Discrimination against out-of-band signals for handsfree MS

The MS is mounted as described in clauses B.4.2.1 or B.4.2.2, annex B. Uplink DTX is deactivated.

A white Gaussian noise signal, bandlimited to 4,6 kHz to 8 kHz is applied at the MRP at a level of $-4,7$ dBPa. The RF output of the MS is first channel and then speech decoded. The total level of the image in the frequency range 300 Hz to 3,4 kHz in this decoded signal shall be below a reference level by the amount specified in clause 3.11.1.2.

C.8.4 Spurious out-of-band emissions for handsfree MS

The MS is mounted as described in clauses B.4.2.1 or B.4.2.2, annex B. Any user controlled receiving volume control is set to maximum. An ITU-T P.50 artificial speech signal in the frequency range 300 Hz to 3,4 kHz and at a level of -12 dBm0 is first speech and then channel encoded and is sent to the MS under test via the air interface. The total level of the spurious out-of-band image signals in the frequency range of 4,6 kHz to 8 kHz is measured in the measuring microphone or as combined at the output of the HATS. The level shall be lower than the in-band acoustic reference level by the amount specified in clause 3.11.2.2.

To obtain the in-band acoustic reference level an ITU-T P.50 artificial speech signal in the frequency range of 300 Hz to 3,4 kHz at a level of -12 dBm0 is first speech and then channel encoded and sent to the MS under test via the air interface. The level of the signal in the frequency range of 300 Hz to 3,4 kHz measured in the measuring microphone or as combined at the output of the HATS is the in-band acoustic reference level.

C.9 Acoustic echo loss

C.9.1 Acoustic echo loss – Handset MS

The MS is mounted at the Loudness Rating Guardring Position (LRGP), (see annex 1 of ITU-T recommendation P.76), with the earpiece sealed to the knife edge of the artificial ear, conforming to ITU-T recommendation P.51.

A call is set up between the MS and the SS.

Where a user controlled volume control is provided it shall be set to maximum.

An implementation of the ITU-T P.50 artificial speech shall be connected to the analogue or digital input of the reference speech encoder of the SS. This implementation could be a real time algorithm producing the artificial speech or a pre-recorded tape of the artificial speech. Both "male" and "female" artificial speech is required.

A ten second segment of the "male" artificial speech is applied to the analogue or digital input of the reference speech encoder of the SS. The third octave power of the input signal shall be measured. The echo loss signal is not measured at this stage as the first ten second segment is used to allow any acoustic echo cancellation devices within the MS to adapt to the echo path.

Immediately afterwards a second ten second segment of the "male" artificial speech is applied to the analogue or digital input of the reference speech encoder of the SS. The third octave power of the echo signal is measured at the digital output of the reference speech decoder of the SS.

The difference between the third octave input power and the third octave output power is entered into the ITU-T Recommendation G.122 TCL algorithm and the acoustic echo loss calculated.

The test shall be repeated with the "female" artificial speech and the results of both "male" and "female" averaged to give the final result.

C.9.2 Acoustic echo loss – Handsfree MS

- The handsfree MS is mounted as specified by the manufacturer and tested according to clauses B.4.2.1 or B.4.2.2, annex B.
- A speech call is set up between the MS and the SS.
- Where a user controlled volume control is provided it shall be set to nominal.
- Artificial speech conforming to ITU-T Recommendation P.50, bandlimited to 200 Hz and 4 kHz shall be applied to the analogue or digital input of the reference speech encoder of the SS, at a level of -10 dBm0. This implementation could be a real time algorithm producing the artificial speech or a pre-recorded tape of the artificial speech.
- The artificial speech shall comprise of a concatenation of three 10 s intervals of "male" and "female" voice. The first 10 s interval is not used for measurement purposes but allows any noise/echo cancelling devices in the MS to adapt. The second and third 10 s intervals consist of separately "male" and "female" artificial voice.
- The 1/3 octave filtered long-term average spectrum of the signal power of the echo signal is measured at the digital output of the reference speech decoder of the SS and an average for the "male" and "female" voices obtained.
- The difference between the 1/3 octave input power and the 1/3 octave output power is entered into the ITU-T G.122 TCL algorithm and the acoustic echo loss calculated.
- Steps b) to g) are repeated with the volume control set to the maximum user-selectable position.

C.10 Delay for handsfree MS

C.10.1 Uplink

Configuration

The handsfree microphone is mounted physically close to the loudspeaker producing the test signal. The RF of the MS is connected to the System Simulator.

NOTE 1: For handsfree equipment fitted with multiple microphones, there must be sufficient sensitivity for one of the microphones for this test to be performed.

Procedure

The SS sets up a handsfree speech call to the MS. The SS sends a known speech like test signal (delytest.pcm) to the loudspeaker of the test system and monitors the received RF bursts.

The SS performs a correlation of the stimulus file with the received, decoded information and calculates the delay.

NOTE 2: The timing of the stimulus signal has to be related to the frame timing and the timing of the received signal has to be related to the frame in which it is received to be able to calculate the delay in the MS.

C.10.2 Downlink

Configuration

The handsfree loudspeaker is mounted physically close to the measuring microphone of the SS. The RF of the MS is connected to the System Simulator.

Procedure

The SS sets up a handsfree speech call to the MS. The SS sends a known speech like test signal (delytest.cod which is the speech coder processed version of delytest.pcm) to the MS and monitors the audio received at the loudspeaker.

The SS performs a correlation of the stimulus file with the received audio and calculates the delay.

NOTE: The timing of the received audio signal has to be related to the frame timing and the timing of the transmitted speech test signal has to be related to the frame in which it is sent to be able to calculate the delay in the MS.

C.10.3 Result

The round trip delay attributable to the MS is the sum of the delay values measured in C.10.1 and C.10.2 less the calibrated delay in the test system.

As the timing of all signals is related to air interface frame timing, the delay in the test system will only be due to operations between the timing system and the acoustic interface. This can be calibrated by running a correlation test, similar to the above, but sending the pcm file to the SS loudspeaker and measuring with the SS microphone. The delay measured by this correlation will be the sum of all the SS delays. Care should be taken in the SS to ensure that this delay is not subject to unnecessary variation.

C.11 Ambient noise rejection

- A 1/2 inch pressure microphone is calibrated using a known sound source and mounted at the MRP, without the LRGP head present. A frequency analyser is calibrated to enable the sound pressure levels at the microphone to be determined in 1/3rd Octave bands.
- Flood the room in which the measurement is to be made with the selected noise file, and adjust the level such that the noise level at the MRP is 70 dBA. A single noise file of real noise, covering the various noise environments that the MS could be subjected to is used ([Filename TBD]). This file is three minutes long and also commences with a three minute calibration signal. Once this tone has been adjusted to a level of 70 dBA, the average level of the noise will be 70 dBA. The resulting sound spectrum is P_{rn} dBPa, measured in 1/3rd Octave bands.
- To ensure that the sound field is diffuse enough, the following apply:
 - The diffuse sound field is calibrated in the absence of any local obstacles. The averaged field shall be uniform to within ± 3 dB within a radius of 0,15 m of the MRP, when measured in one-third octave bands from 100 Hz to 3,15 kHz.

NOTE 1: The pressure intensity index, as defined in ISO 9614, may prove to be a suitable method for assessing the diffuse field.

NOTE 2: Where more than one loudspeaker is used to produce the desired sound field, the loudspeakers may require to be fed with non-coherent electrical signals to eliminate standing waves and other interference effects.

- Position an LRGP in the correct relative position to the MRP and mount the MS underneath. Recalibrate the 1/3rd Octave frequency analyser using a known voltage source to facilitate the analysis of the voltage V_{rn} , where V_{rn} is the voltage at the audio output of the SS due to the noise spectrum input.
- Set up a speech path between the MS and the System Simulator (SS).
- Determine, as a function of frequency, using the frequency analyser, in 1/3rd Octave bands, the electrical output V_{rn} , (expressed as dB rel. 1V) at the audio output of the SS for the applied acoustic pressure P_{rn} (expressed as dB rel 1Pa) at the MRP. Since, the MS sending sensitivity is not defined above 3,4 kHz and below 300 Hz the measurement shall be cut off at 3,4 kHz and for the bands below 300 Hz, the noise level shall be referenced to the speech level at 300 Hz to yield the DELSM.

The room noise sensitivity is expressed as:- $S_{mj_{rn}} = V_{rn} \text{ (dBV)} - P_{rn} \text{ (dBPa)}$.

The MS ambient noise send sensitivity has now been determined.

- The MS speech send sensitivity is now required. The required sensitivity is defined as the electrical output from the MS, measured at the audio output of the SS, as a function of the free field sound pressure at the MRP of the artificial mouth.

The measurement is made using an artificial speech source at the MRP of the artificial mouth. The 1/2 inch pressure microphone is calibrated using a known sound source. The frequency analyser is calibrated to measure in 1/3rd Octave bands. The artificial mouth output shall be in accordance with the CCITT P.50 male artificial voice. Whilst maintaining the CCITT P.50 "male" spectrum, adjust the total signal level to $-4,7$ dBPa. The resulting sound spectrum is P_o dBPa, measured in 1/3rd Octave bands. The 1/3rd Octave frequency analyser should be re-calibrated, using a known voltage source, to facilitate the analysis of the voltage V_j . Where V_j is the voltage at the audio output of the SS due to the speech spectrum input. Set up a speech path between the MS and the SS. Determine the function of frequency, using the frequency analyser, and in 1/3rd Octave bands, the electrical output, V_j , (expressed as dB rel. 1V), at the audio output of the SS for the applied acoustic pressure, P_o , (expressed as dB rel. 1Pa/V), at the MRP.

The sending sensitivity is expressed as:

- $S_{mjs} \text{ (dB)} = V_j \text{ (dBV)} - P_o \text{ (dBPa)} \text{ dB rel. 1V/Pa}$.

The D_{SM} for the MS is determined as:

$$- D_{SM} = S_{mj_{rn}} - S_{mjs} \text{ (dB)}.$$

C.11.1 Full-Rate, (TCH-FS) MS Ambient Noise Rejection (handset MS)

Compliance shall be checked by calculating the Single Figure DELSM (SFDELSM) according to the following formula, the SFDELSM shall be ≥ 0 dB.

Where:- n = The of third octave band centre frequencies from 160 Hz to 3 150 Hz inclusive.

De_{ln} = is the $1/3^{\text{rd}}$ Octave band pressure level centred on the n_{th} frequency.

W_m = is the SLR weighting for the n^{th} $1/3^{\text{rd}}$ Octave band centre frequency.

14

$$SFDELSM = -4/5 \times \sum_{n=1} De_{ln} \times 10^{(-0.0175 \times W_m)}$$

C.11.2 Full-Rate, (TCH-FS) MS Ambient Noise Rejection (handsfree MS)

[TBD]

C.11.3 Half-Rate, (TCH-HS) MS and Dual-Rate (TCH-FS and TCH-HS) MS Ambient Noise Rejection

[TBD]

Annex D (normative): MS delay requirement definition

D.1 Full rate MS delay requirement definition

The symbol definitions for the calculations in this clause are:

Trftx:	The time required for transmission of a TCH radio interface frame over the air interface due to the interleaving and de-interleaving (system dependent).
Ttransc:	The speech encoder processing time, from input of the last PCM sample to output of the final encoded bit (implementation dependent).
Tsample:	The duration of the segment of PCM speech operated on by the speech transcoder.
Tencode:	The time required for the channel encoder to perform channel encoding (implementation dependent).
Trxproc:	The time required after reception over the air interface to perform equalization, channel decoding and SID frame detection (implementation dependent).
Tproc:	The time required after reception of the first RPE-sample to process the speech encoded data for the full rate speech decoder and to produce the first PCM output sample (implementation dependent).
Ta/d:	Delay in the analogue to digital converter in the downlink.
Tmargin:	An allowance for system entities that are implementation dependent.
Td/a:	Delay in the digital to analogue converter in the uplink.
Tpcm:	The duration of a segment of PCM speech for the downlink processing delay.

The full rate MS speech delay in the uplink direction is the delay between an acoustic event at the MRP to the last bit of the corresponding speech frame at the antenna connector and shall not exceed:

$$\begin{aligned}
 \text{MS uplink delay} &= T_{a/d} + T_{\text{margin}} + T_{\text{sample}} + T_{\text{transc}} + T_{\text{encode}} + T_{\text{rftx}} \\
 &= 2,0 + 3,0 + 20,0 + 8,0 + 1,6 + 37,5 \text{ ms} \\
 &= 72,1 \text{ ms}
 \end{aligned}$$

The full rate MS speech delay in the downlink direction is the delay between the first bit of a speech frame at the antenna connector and the last acoustic event at the ERP corresponding to that speech frame and shall not exceed:

$$\begin{aligned}
 \text{MS downlink delay} &= T_{\text{pcm}} + T_{\text{rftx}} + T_{\text{rxproc}} + T_{\text{proc}} + T_{\text{margin}} + T_{d/a} \\
 &= 20,0 + 37,5 + 8,8 + 1,5 + 3,0 + 1,0 \text{ ms} \\
 &= 71,8 \text{ ms}
 \end{aligned}$$

The round trip delay shall therefore not exceed:

$$72,1 \text{ ms} + 71,8 \text{ ms} = 143,9 \text{ ms}.$$

D.2 Half rate MS delay requirement definition

The symbol definitions for the calculations in this clause are:

Trftx:	The time required for transmission of a TCH radio interface frame over the air interface due to the interleaving and de-interleaving (system dependent).
Ttransc:	The speech encoder processing time, from input of the last PCM sample to output of the final encoded bit (implementation dependent).
Tsample:	The duration of the segment of PCM speech operated on by the speech transcoder.
Tencode:	The time required for the channel encoder to perform channel encoding (implementation dependent).
Trxproc:	The time required after reception over the air interface to perform equalization, channel decoding and SID frame detection (implementation dependent).
Tproc:	The time required after reception of the first gain vector (GSPO) to process the speech encoded data for the half rate speech decoder and to produce the first PCM output sample (implementation dependent).
Ta/d:	Delay in the analogue to digital converter in the downlink.
Tmargin:	An allowance for system entities that are implementation dependent.
Td/a:	Delay in the digital to analogue converter in the uplink.
Tpcm:	The duration of a segment of PCM speech for the downlink processing delay.

The half rate MS speech delay in the uplink direction is the delay between an acoustic event at the MRP to the last bit of the corresponding speech frame at the antenna connector and shall not exceed:

$$\begin{aligned}
 \text{MS uplink delay} &= T_{a/d} + T_{\text{margin}} + T_{\text{sample}} + T_{\text{transc}} + T_{\text{encode}} + T_{\text{rftx}} \\
 &= 1,0 + 1,9 + 24,4 + 12,1 + 1,2 + 32,9 \text{ ms} \\
 &= 73,5 \text{ ms}
 \end{aligned}$$

The half rate MS speech delay in the downlink direction is the delay between the first bit of a speech frame at the antenna connector and the last acoustic event at the ERP corresponding to that speech frame and shall not exceed:

$$\begin{aligned}
 \text{MS downlink delay} &= T_{\text{pcm}} + T_{\text{rftx}} + T_{\text{rxproc}} + T_{\text{proc}} + T_{\text{margin}} + T_{d/a} \\
 &= 24,4 + 32,9 + 8,8 + 1,9 + 1,9 + 0,5 \text{ ms} \\
 &= 70,4 \text{ ms}
 \end{aligned}$$

The round trip delay shall therefore not exceed:

143,9 ms (see clause 3.3.6.2).

Annex E (informative): Adaptive gain control

In noisy surroundings the speaker automatically raises his voice to compensate for the noise. The sending sensitivity can therefore be reduced, giving the same voice output to the line as under quiet conditions and at the same time reducing the output line noise level.

On the other hand the receiving sensitivity has to be increased under noisy conditions to give a better perceived sound quality.

The Sending and receiving sensitivities may be modified automatically by implementing an Adaptive gain control. The gain variation in the set corresponds to a gain in the receiving path and to a symmetrical attenuation in the sending path for increased ambient noise level.

The following table presents, for guidance and illustration only, three examples of gain variation characteristics.

Table E.1: Gain variation characteristics

	Ambient noise level	Relative Gain variation
Single threshold	between -44 and -39 dBP _a (A)	8 dB
Double threshold	-44 dBP _a (A)	5 dB
	-34 dBP _a (A)	10 dB
Continuous variation	from -64 to -44 dBP _a (A)	3 dB
	from -44 to -24 dBP _a (A)	8 dB

Annex F (informative): Change Request History

SMG#	SPEC	CR	PHASE	VERS	NEW_VERS	SUBJECT
S17	03.50	A005	2+		5.0.0	New specification for handsfree performance
S17	03.50	A006	2+		5.0.0	Noise reduction Specification for the GSM MS.
S17	03.50	A007	2+		5.0.0	Inclusion of the possibility to use a type 3.2 leaky ear for handset tests.
S17	03.50	A008	2+		5.0.0	Update of references
s24	03.50	A011	R96	5.0.2	5.0.3	CR to 03.50 Correction of wrong reference to ITU-T Recommendation
s25	03.50	A013	R96	5.0.3	5.1.0	Removal of inconsistency in RLR for Handset and Headset MS
s27	03.50	A014	R96	5.1.0	5.2.0	Correction of reference in Section 1.1
s27	03.50				6.0.0	Release 1997 version
s28	03.50	A018	R97	6.0.0	6.1.0	Acoustic testing of MS over the air interface
s29	03.50				7.0.0	Upgrade to Release 1998 version 7.0.0
	03.50			7.0.0	7.0.1	Update to version 7.0.1 for Publication
s31	03.50			7.0.1	8.0.0	Release 1999 version 8.0.0
s32	03.50	A022	R99	8.0.0	8.1.0	Addition of a new optional artificial ear Type for acoustic tests
	03.50			8.1.0	8.1.1	Update to Version 8.1.1 for Publication

History

Document history			
V8.0.0	April 2000	One-step Approval Procedure	OAP 20000818: 2000-04-19 to 2000-08-18
V8.1.0	July 2000	One-step Approval Procedure	OAP 20001124: 2000-07-26 to 2000-11-24
V8.0.1	September 2000	Publication	
V8.1.1	November 2000	Publication	