

3GPP TS 03.41 V7.4.0 (2000-09)

Technical Specification

3rd Generation Partnership Project; Technical Specification Group Terminals; Technical realization of Cell Broadcast Service (CBS) (Release 1998)



The present document has been developed within the 3rd Generation Partnership Project (3GPP™) and may be further elaborated for the purposes of 3GPP.

The present document has not been subject to any approval process by the 3GPP Organisational Partners and shall not be implemented.

This Specification is provided for future development work within 3GPP only. The Organisational Partners accept no liability for any use of this Specification.

~~Specifications and reports for implementation of the 3GPP™ system should be obtained via the 3GPP Organisational Partners' Publications Offices.~~

Keywords

GSM, terminal, broadcast

3GPP

Postal address

3GPP support office address

650 Route des Lucioles - Sophia Antipolis
Valbonne - FRANCE
Tel.: +33 4 92 94 42 00 Fax: +33 4 93 65 47 16

Internet

<http://www.3gpp.org>

Copyright Notification

No part may be reproduced except as authorized by written permission.
The copyright and the foregoing restriction extend to reproduction in all media.

© 2000, 3GPP Organizational Partners (ARIB, CWTS, ETSI, T1, TTA, TTC).
All rights reserved.

Contents

Foreword	5
1 Scope	6
1.1 References	6
1.2 Abbreviations	7
2 General description	7
3 Network Architecture	7
4 CBE Functionality	8
5 CBC Functionality	8
6 BSC Functionality	9
7 BTS Functionality	9
8 MS Functionality	9
9 Protocols and Protocol Architecture	10
9.1 CBC-BSC Primitives	12
9.1.1 Identification of a message	12
9.1.2 WRITE-REPLACE Request/Indication	13
9.1.3 KILL Request/Indication	14
9.1.4 REPORT Response/Confirm	15
9.1.5 STATUS-CBCH-QUERY Request/Indication	15
9.1.6 STATUS-CBCH-QUERY Response/Confirm	15
9.1.7 STATUS-MESSAGE-QUERY Request/Indication	16
9.1.8 STATUS-MESSAGE-QUERY Response/Confirm	16
9.1.9 REJECT Response/Confirm	16
9.1.10 RESTART-INDICATION Request/Indication	16
9.1.11 RESET Request/Indication	17
9.1.12 FAILURE-INDICATION Request/Indication	17
9.1.13 SET-DRX Request/Indication	17
9.1.14 SET-DRX- REPORT Response/Confirm	18
9.2 Parameters	18
9.2.1 Message-Identifier	18
9.2.2 Old-Serial-Number	18
9.2.3 New-Serial-Number	18
9.2.4 Number-of-Pages	18
9.2.5 Cell-List	18
9.2.5.1 Cell-List sent from CBC to BSC	19
9.2.5.2 Cell-List sent from BSC to CBC	19
9.2.6 Channel Indicator	19
9.2.7 Category	19
9.2.8 Repetition-Period	20
9.2.9 No-of-Broadcasts-Requested	20
9.2.10 No-of-Broadcasts-Completed-List	20
9.2.11 Cell-Identifier	21
9.2.12 Schedule-Period	21
9.2.13 Reserved-Slots	21
9.2.14 Failure-List	21
9.2.15 CBCH-Loading-List	22
9.2.16 Cause	23
9.2.17 Diagnostic	23
9.2.18 Data Coding Scheme	23
9.2.19 CBS-Message-Information-Page n	23
9.2.20 CBS-Message-Information-Length n	24

9.2.21 Recovery-Indication..... 24

9.3 Message Format on BTS-MS Interface..... 24

9.3.1 General Description 24

9.3.2 Message Parameter 24

9.3.2.1 Serial Number..... 25

9.3.2.2 Message Identifier 26

9.3.2.3 Data Coding Scheme..... 27

9.3.2.4 Page Parameter..... 27

9.3.2.5 Content of Message 27

9.4 CBS Compression 27

10 CBS Index..... 28

Annex A (informative): Protocols for interconnecting CBC and BSC..... 31

Annex B (informative): Change History..... 32

Foreword

This Technical Specification (TS) has been produced by the Special Mobile Group (SMG).

The present document defines the Cell Broadcast short message service (CBS). It defines the primitives over the Cell Broadcast Centre - Base Station System (CBC-BSS) interface and the message formats over the Base Station System - Mobile Station (BSS-MS) interface for Teleservice 23 within the digital cellular telecommunications system (Phase 2+).

The contents of the present document are subject to continuing work within 3GPP TSG T and may change following formal 3GPP TSG T approval. Should 3GPP TSG T modify the contents of the present document it will then be republished by ETSI with an identifying change of release date and an increase in version number as follows:

Version 7.x.y

where:

- 7 indicates Release 1998 of GSM Phase 2+
- x the second digit is incremented for changes of substance, i.e. technical enhancements, corrections, updates, etc.
- y the third digit is incremented when editorial only changes have been incorporated in the specification.

1 Scope

The present document describes the Cell Broadcast short message service (CBS). It defines the primitives over the Cell Broadcast Centre - Base Station System (CBC-BSS) interface and the message formats over the Base Station System - Mobile Station (BSS-MS) interface for Teleservice 23 as specified in GSM 02.03 [2].

1.1 References

The following documents contain provisions which, through reference in this text, constitute provisions of the present document.

- References are either specific (identified by date of publication, edition number, version number, etc.) or non-specific.
- For a specific reference, subsequent revisions do not apply.
- For a non-specific reference, the latest version applies.
- A non-specific reference to an ETS shall also be taken to refer to later versions published as an EN with the same number.
- For this Release 1998 document, references to GSM documents are for Release 1998 versions (version 7.x.y).

- [1] GSM 01.04: "Digital cellular telecommunication system (Phase 2+); Abbreviations and acronyms".
- [2] GSM 02.03: "Digital cellular telecommunication system (Phase 2+); Teleservices supported by a GSM Public Land Mobile Network (PLMN)".
- [3] GSM 03.38: "Digital cellular telecommunication system (Phase 2+); Alphabets and language-specific information".
- [4] GSM 03.40: "Digital cellular telecommunication system (Phase 2+); Technical realization of the Short Message Service (SMS) Point to Point (PP)".
- [5] GSM 03.47: "Digital cellular telecommunication system (Phase 2+); Example protocol stacks for interconnecting Service Centre(s) (SC) and Mobile-services Switching Centre(s) (MSC)".
- [6] GSM 03.49: "Digital cellular telecommunication system (Phase 2+); Example protocol stacks for interconnecting Cell Broadcast Centre (CBC) and Mobile-services Switching Centre (MSC)".
- [7] GSM 04.12: "Digital cellular telecommunication system (Phase 2+); Short Message Service Cell Broadcast (SMS-CB) support on the mobile radio interface".
- [8] GSM 05.02: "Digital cellular telecommunication system (Phase 2+); Multiplexing and multiple access on the radio path".
- [9] GSM 07.05: "Digital cellular telecommunication system (Phase 2+); Use of Data Terminal Equipment - Data Circuit terminating Equipment (DTE - DCE) interface for Short Message Service (SMS) and Cell Broadcast Service (CBS)".
- [10] GSM 08.52: "Digital cellular telecommunication system (Phase 2+); Base Station Controller - Base Transceiver Station (BSC - BTS) interface Interface principles".
- [11] GSM 08.58: "Digital cellular telecommunication system (Phase 2+); Base Station Controller - Base Transceiver Station (BSC - BTS) interface Layer 3 specification".
- [12] CCITT Recommendation X.210: "Open systems interconnection layer service definition conventions".
- [13] GSM 08.08: "MSC-BSS Interface Layer 3 specification".
- [14] GSM 03.42: "Compression algorithm for text messaging services".

- [15] GSM 03.48: "Digital cellular telecommunications system (Phase 2+); Security Mechanisms for the SIM application toolkit; Stage 2".

1.2 Abbreviations

Abbreviations used in the present document are listed in GSM 01.04 [1].

2 General description

The CBS service is analogous to the Teletex service offered on television, in that like Teletex, it permits a number of unacknowledged general messages to be broadcast to all receivers within a particular region. CBS messages are broadcast to defined geographical areas known as cell broadcast areas. These areas may comprise of one or more cells, or may comprise the entire PLMN. Individual CBS messages will be assigned their own geographical coverage areas by mutual agreement between the information provider and the PLMN operator. CBS messages may originate from a number of Cell Broadcast Entities (CBEs), which are connected to the Cell Broadcast Centre. CBS messages are then sent from the CBC to the BTSs, in accordance with the CBS's coverage requirements.

The CBS message comprises of 82 octets, which, using the default character set, equates to 93 characters. Up to 15 of these messages (pages) may be concatenated to form a macromessage. Each page of such macromessages will have the same message identifier (indicating the source of the message), and the same serial number. Using this information, the MS is able to identify and ignore re-broadcasts of already received messages.

CBS messages are broadcast cyclically by the BTS at a frequency and for a duration agreed with the information provider. The frequency at which messages are repeatedly transmitted will be dependent on the information that they contain; for example, it is likely that dynamic information such as road traffic information, will require more frequent transmission than weather information. The repetition period will also be affected by the desire for messages to be received by high speed mobiles which rapidly traverse cells. All suitably equipped mobiles within the catchment area of the transmitting BTS will be able to receive the broadcast messages, provided that they are switched on and in the idle state.

CBS messages may be broadcast on two different cell broadcast channels, which are characterized by different QoS. A MS is always able to read the basic channel (see [8]). The reading of the extended channel may collide with other tasks of the MS. Therefore the probability of receiving a CBS message on the extended channel is smaller than on the basic channel. The reading of the extended channel for MSs is optional. The scheduling on the channels will be done independently.

To permit mobiles to selectively display only those messages required by the MS user, CBS messages are assigned a message class which categorises the type of information that they contain and the language in which the message has been compiled. Through the use of appropriate MMI, the user is then able to ignore message types that he does not wish to receive, e.g. advertising information or messages in an unfamiliar language.

3 Network Architecture

The basic network structure of CBS is depicted by figure 1.

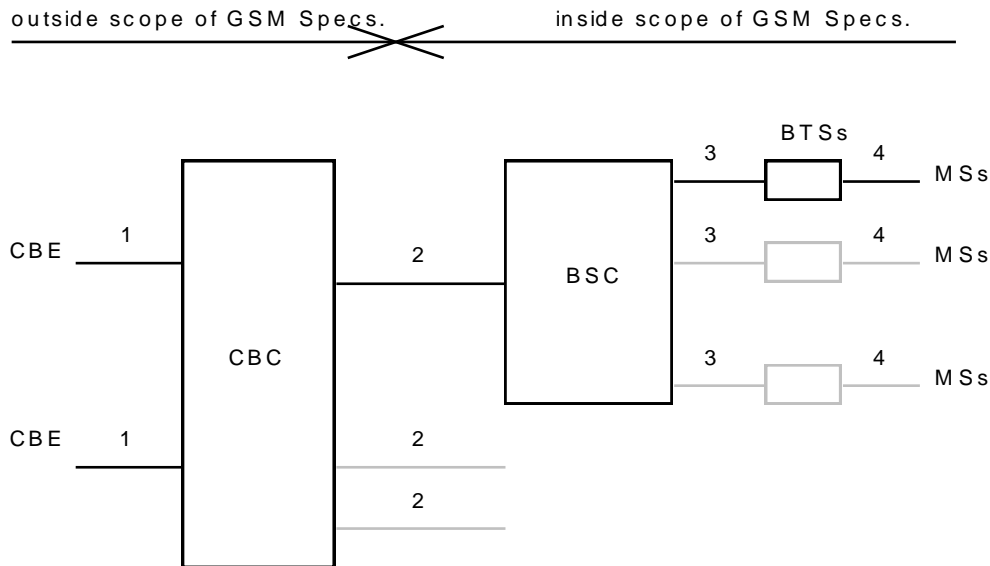

Figure 1

- message transfer on link 1 is outside the scope of GSM Specifications;
- message transfer on link 2 is described in subclause 9.1;
- message transfer on link 3 is described in GSM 08.58;
- message transfer on link 4 is described in GSM 04.12 and the timing of messages transferred on link 4 is described in GSM 05.02.

4 CBE Functionality

The functionality of the CBE is outside of the scope of GSM Specifications; however it is assumed that the CBE is responsible for all aspects of formatting CBS, including the splitting of a CBS message into a number of pages.

5 CBC Functionality

As the CBC (and any originating point for cell broadcast short messages) is regarded as a node outside the PLMN, only the requirements placed upon the CBC by CBS functionality are specified by this specification.

The CBC may be connected to several BSCs. The CBC may be connected to several CBEs. The CBC shall be responsible for the management of cell broadcast short messages including:

- allocation of serial numbers;
- modifying or deleting messages held by the BSC;
- initiating broadcast by sending fixed length cell broadcast short messages to a BSC for each language provided by the cell, and where necessary padding the message to a length of 82 octets [see GSM 03.38];
- determining the set of cells/BTSs to which a message should be broadcast, and indicating within the Serial Number the geographical scope of each message;
- determining the time at which a message should commence being broadcast;
- determining the time at which a message should cease being broadcast and subsequently instructing each BSC to cease broadcast of the message;
- determining the period at which broadcast of the message should be repeated;

- determining the cell broadcast channel, on which the message should be broadcast.

To work efficiently on the interfaces, the BSC - which is normally controlling more than one cell of a broadcast area - should be used as a concentrator as far as CB message handling is concerned. Hence, the CBC should work on lists of cells when issuing CB related requests towards the BSC.

6 BSC Functionality

The BSC shall interface to only one CBC. A BSC may interface to several BTSs as indicated by GSM 08.52. The BSC shall be responsible for:

- interpretation of commands from the CBC;
- storage of cell broadcast messages;
- scheduling of cell broadcast messages on the CBCH;
- providing an indication to the CBC when the desired repetition period cannot be achieved;
- providing to the CBC acknowledgement of successful execution of commands received from the CBC;
- reporting to the CBC failure when a command received from the CBC is not understood or cannot be executed;
- routing cell broadcast messages to the appropriate BTSs;
- transferring CBS information to each appropriate BTS via a sequence of 4 SMS BROADCAST REQUEST messages or 1 SMS BROADCAST COMMAND message (see GSM 08.58), indicating the channel which shall be used.
- optionally generating Schedule Messages, indicating the intended schedule of transmissions (see GSM 04.12);
- optionally receiving CBCH Load Indication messages and reacting by broadcasting a burst of scheduled CBS messages or by suspending the broadcast for a period indicated by BTS (see GSM 08.58);

To work efficiently on the interfaces, the BSC should forward CB related messages to the CBC using cell lists as far as applicable.

7 BTS Functionality

The BTS is responsible for conveying CBS information received via SMS BROADCAST REQUEST or SMS BROADCAST COMMAND messages over the radio path to the MS.

- optionally generating CBCH Load Indication messages, indicating an underflow or overflow situation on the CBCH (see GSM 08.58).

8 MS Functionality

The MS is responsible for recombination of the blocks received via the radio path to reconstitute the cell broadcast short message. The precise method of display of cell broadcast short messages is outside the scope of GSM Specifications, however it is assumed that an MS will:

- discard sequences transferred via the radio path (see GSM 04.12) which do not consist of consecutive blocks;
- have the ability to discard CBS information which is not in a suitable data coding scheme;
- have the ability to discard a message which has a message identifier indicating that it is of subject matter which is not of interest to the MS;

- have the ability to ignore repeat broadcasts of messages already received (message has not changed since it was last broadcast i.e. sequence number has not changed within the message's indicated geographical area);
- have the ability to transfer a message to an external device, when supported ;
- optionally enter CBS DRX mode based upon received Schedule Messages (see GSM 04.12);
- optionally skip reception of the remaining block(s) of a cell broadcast message which do(es) not contain cell broadcast information (see GSM 04.12);
- optionally read the extended channel.

9 Protocols and Protocol Architecture

Commands interpreted by the BSC will result in a sequence of 4 SMS BROADCAST REQUEST messages or 1 SMS BROADCAST COMMAND message being sent to a BTS, which in turn result in a sequence of 4 messages being transferred via the BTS-MS interface (see GSM 04.12).

With the SMS BROADCAST REQUEST mode of operation, the 88 octet fixed length CBS page which is specified in Section 9.3 is split into four 22 octet blocks which are carried in SMS BROADCAST REQUEST messages as follows:

- octets 1-22 are transferred in the 1st SMS BROADCAST REQUEST
with a sequence number (see GSM 04.12) indicating first block
- octets 23-44 are transferred in the 2nd SMS BROADCAST REQUEST
with a sequence number (see GSM 04.12) indicating second block
- octets 45-66 are transferred in the 3rd SMS BROADCAST REQUEST
with a sequence number (see GSM 04.12) indicating third block
- octets 67-88 are transferred in the 4th SMS BROADCAST REQUEST
with a sequence number (see GSM 04.12) indicating fourth block.

Figure 2 illustrates the protocol architecture and the scope of the various GSM Specifications for the SMS BROADCAST REQUEST mode of operation.

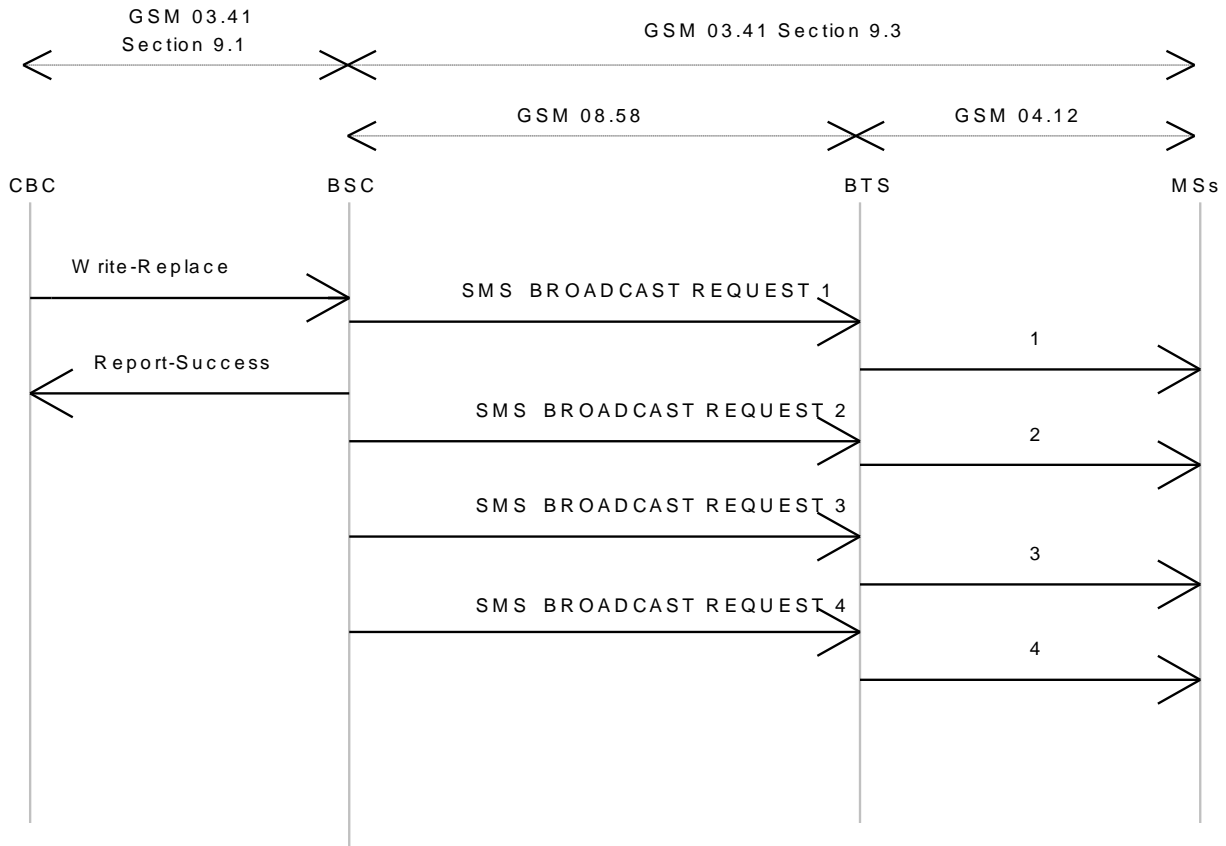

Figure 2

With the SMS BROADCAST COMMAND mode of operation, the BSC sends to the BTS in one single message the 88 octet fixed length CBS page. The BTS then splits the page into four 22 octet blocks, adds the sequence number (see GSM 04.12) and transmits the four resulting blocks on the air.

Figure 3 illustrates the protocol architecture and the scope of the various GSM Specifications for the SMS BROADCAST COMMAND mode of operation.

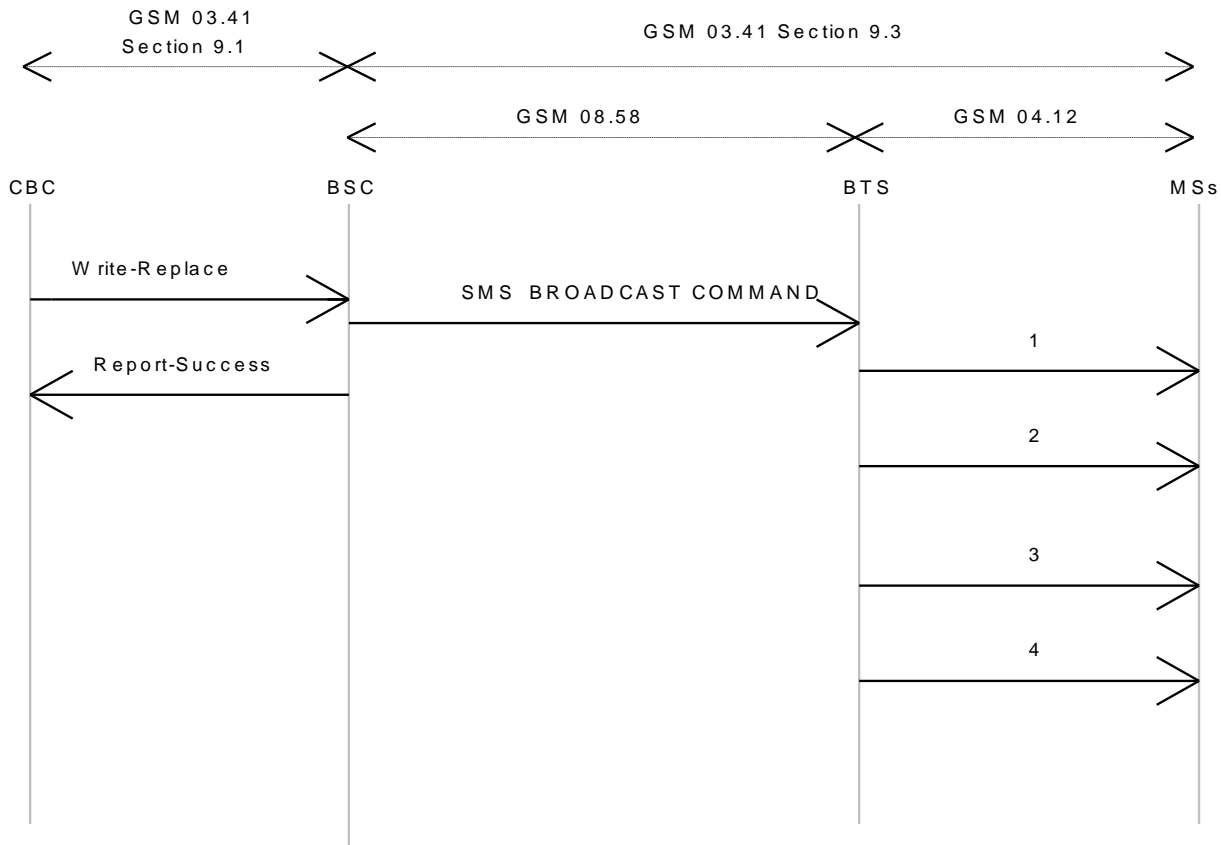

Figure 3

9.1 CBC-BSC Primitives

The term primitive is used to indicate "an abstract, implementation independent interaction between a service user and a service provider" (see CCITT X.210). For the CBC-BSC interface, the service provider would be the protocol interconnecting CBC and BSC. A Primitive may therefore be viewed as an abstract, implementation independent request/indication or response/confirm interaction between the service user (CBC or BSC) and the service provider (protocol). A set of primitives for use between the CBC and BSC is specified appropriate to the functionality assigned to the CBC and BSC in Sections 5 and 6. In order to allow future extensions to the primitives, where possible a primitive shall not be rejected because a parameter is not recognised; the recipient shall ignore the parameter in question and process the remainder of the primitive's parameters as usual. No mandatory protocol between the CBC and the BSC is specified by GSM, this is a matter of agreement between CBC and PLMN operators. GSM 03.49 (see also annex A of the present document) provides example protocol stacks using the primitives defined as follows.

NOTE: In the following definitions, M indicates "mandatory parameter" and O indicates "optional parameter".

9.1.1 Identification of a message

Within a CBC-BSC interface, a message is uniquely identified by the quartet (Message Identifier, Serial Number, Cell Identifier, Channel Indicator). This means that even when two messages have the same semantic contents (for example the same weather forecast) but in different languages or coding schemes, they are considered as different and must therefore be identified by a different quartet.

The Serial Number (Old-Serial-Number or New-Serial-Number) is managed cyclically and therefore this does not prevent the re-use of the same quartet for a different message when the serial number have been incremented a sufficient number of times. How to manage the ambiguity is described subsequently.

This unique identification of a message across the CBC-BSC interface is used in all the primitives defined hereafter. This means that the quartet will be implicitly or explicitly present in every interface primitive which applies to a given message.

This unique quartet will be referred in the rest of the document as the « message reference ».

9.1.2 WRITE-REPLACE Request/Indication

PARAMETER	REFERENCE	PRESENCE
Message-Identifier	9.2.1	M
Old-Serial-Number	9.2.2	O
New-Serial-Number	9.2.3	M
Cell-List	9.2.5.1	M
Channel Indicator	9.2.6	O
Category	9.2.7	O
Repetition-Period	9.2.8	M
No-of-Broadcasts-Requested	9.2.9	M
Number-of-Pages	9.2.4	M
Data Coding Scheme	9.2.18	M
CBS-Message-Information-Page 1	9.2.19	M
CBS-Message-Information-Length 1	9.2.20	M
CBS-Message-Information-Page 2	9.2.19	O
CBS-Message-Information-Length 2	9.2.20	O
:		:
CBS-Message-Information-Page n	9.2.19	O
CBS-Message-Information-Length n	9.2.20	O

This primitive is sent by the CBC to the BSC. As this primitive can be used either to broadcast a new message or replace a message already broadcast, the CBC will use the presence and content of the Old-Serial-Number and New-Serial-Number fields in this primitive to instruct the BSC as follows:-

- Old-Serial-Number not present/New-Serial-Number present

This is a write request which will be interpreted by the BSC as an instruction to broadcast a new message in all the cells of the Cell list and on the channel derived by the Channel Indicator (see the section on parameters that describes the implicit value of the Channel Indicator when not present in the message). The following table identifies the BSC's behaviour:

Success/Failure of write request	BSC behaviour
Success	<p>The BSC completes the following parameters to be returned in the Report PDU:</p> <ul style="list-style-type: none"> • a '0' value is entered in the number of broadcasts completed list for the cell • no entry is made in the failure list for the cell
Failure	<p>The BSC completes the following parameters to be returned in the Report PDU:</p> <ul style="list-style-type: none"> • no entry is made in the number of broadcasts completed list for the cell • an entry is made in the failure list for the new message identifying the failure cause for the cell

The BSC will build as many message references as the number of cells in the list. These message references will be used in particular in the subsequent primitives.

When a message reference is already known by the BSC for certain cells in the list (even if the Update field of the Serial-Number is different), the primitive will be rejected with the cause « message reference already used ». The list of cells where the message reference is not valid will be provided in the REPORT message. No entry will be made in the number of broadcasts completed parameter.

- Old-Serial-Number present/New-Serial-Number present.

This is a replace request which will be interpreted by the BSC as a kill request for the message with the old serial number, followed by a write request for the message with the new serial number. The handling of the new serial number in the write part of this request, is as described above in the write request where no Old-Serial-Number is supplied. These two kill and write requests are executed sequentially. If the kill request is unsuccessful, the BSC does not proceed to execute the write request. The kill request will stop broadcast of, and cause all information currently associated with the combination of message identifier, old serial number, Channel Indicator and the list of cells in the Cell list to be deleted from the cells in the BSC (i.e. for all cells provided in the Cell-List parameter). If the kill request is successful, the subsequent write request information conveyed in the primitive replaces the killed message. The following table identifies the BSC's behaviour:

Success/Failure of kill request	BSC behaviour
Success	<p>The BSC proceeds to execute the write request:</p> <ul style="list-style-type: none"> • Write successful: the BSC completes the following parameters to be returned in the Report PDU: <ul style="list-style-type: none"> • an entry is made in the number of broadcasts completed list for the cell • no entry is made in the failure list for the cell • Write unsuccessful: the BSC completes the following parameters to be returned in the Report PDU: <ul style="list-style-type: none"> • an entry is made in the number of broadcasts completed list for the cell • an entry is made in the failure list for the new message identifying the failure cause for the cell
Failure	<p>The BSC does not proceed to execute the write request, and completes the following parameters to be returned in the Report PDU:</p> <ul style="list-style-type: none"> • no entry is made in the number of completed broadcasts list • an entry is made for the old message in the failure list identifying the failure cause for the cell

All cells which should perform the broadcasting are mentioned in the Cell-List parameter.

The broadcast of the referenced message in the cells which are not mentioned in the Cell-List remains unaffected.

If no category is present, the default category is interpreted by the BSC, see the parameter section.

This primitive is responded by a REPORT or REJECT primitive.

NOTE: in the case of multipage messages, the individual pages are considered as independent by the BSC scheduling algorithm.

9.1.3 KILL Request/Indication

PARAMETER	REFERENCE	PRESENCE
Message-Identifier	9.2.1	M
Old-Serial-Number	9.2.2	M
Cell-List	9.2.5.1	M
Channel Indicator	9.2.6	O

This primitive is sent by the CBC to the BSC. The CBC will use this primitive to kill the message indicated by the combination of message identifier, serial number, Channel Indicator and the cells indicated in the Cell-List of this KILL request, i.e. the primitive will halt broadcast of the message in the indicated cells and remove any knowledge of the message from the BSC for these cells. The broadcast of the referenced message in the cells which are not mentioned in the Cell-List remains unaffected. This primitive is responded with a REPORT or REJECT primitive.

9.1.4 REPORT Response/Confirm

PARAMETER	REFERENCE	PRESENCE
Message-Identifier	9.2.1	M
Serial-Number	9.2.2/9.2.3	M
Channel Indicator	9.2.6	O
No-of-Broadcasts-Completed-List	9.2.10	O
Failure-List	9.2.14	O

This primitive will be sent by the BSC to the CBC in response to WRITE-REPLACE and KILL primitives. The Serial-Number field will contain the old serial number if this primitive is sent in response to a KILL primitive, and the new serial number if the primitive is sent in response to a WRITE-REPLACE primitive.

The No-of-Broadcasts-Completed-List if present, may contain for each cell the number of broadcasts of the (replaced or killed) CB message with the old message reference sent to this particular cell for broadcast. The serial number information element in the case of a WRITE-REPLACE does not refer to the message for which the number of broadcasts completed information is supplied. The Failure-List if present, may contain those cells which were present in the related WRITE-REPLACE or KILL primitive and failed the requested operation.

9.1.5 STATUS-CBCH-QUERY Request/Indication

PARAMETER	REFERENCE	PRESENCE
Cell-List	9.2.5.1	M
Channel Indicator	9.2.6	O

This primitive is sent by the CBC to the BSC in order to obtain the current loading of the CBCH of particular cells referenced in the Cell-List parameter. This primitive is responded by a STATUS-CBCH-QUERY Response/Confirm or a REJECT primitive.

9.1.6 STATUS-CBCH-QUERY Response/Confirm

PARAMETER	REFERENCE	PRESENCE
CBCH-Loading-List	9.2.15	O
Failure-List	9.2.14	O
Channel Indicator	9.2.6	O

This primitive will be sent by the BSC in response to the STATUS-CBCH-QUERY Request/Indication primitive.

The CBCH-Loading-List, if present, may contain each cell which successfully performed the requested operation and for each of these cells the CBCH loading of this particular cell. (Note that for cells with DRX the load caused by the schedule messages will be included in the CBCH load). The CBCH-Loading-List will not be present if all cells indicated in the related STATUS-CBCH-QUERY Request/Indication failed the requested operation.

The Failure-List, if present, may contain all cells for which the requested operation failed (e.g. because the cells CBCH is not available). The STATUS-CBCH-QUERY Response/Confirm will not contain the Failure-List parameter if none of the cells in the Cell-List of the related STATUS-CBCH-QUERY Request failed the requested operation.

9.1.7 STATUS-MESSAGE-QUERY Request/Indication

PARAMETER	REFERENCE	PRESENCE
Message-Identifier	9.2.1	M
Old-Serial-Number	9.2.2	M
Cell-List	9.2.5.1	M
Channel Indicator	9.2.6	O

This primitive is sent by the CBC to the BSC in order to obtain the current status of a CB-message for the cells referenced in the Cell-List parameter. This primitive is responded by the STATUS-MESSAGE-QUERY Response/Confirm or by a REJECT Response/Confirm.

9.1.8 STATUS-MESSAGE-QUERY Response/Confirm

PARAMETER	REFERENCE	PRESENCE
Message-Identifier	9.2.1	M
Old-Serial-Number	9.2.2	M
No-of-Broadcasts-Completed-List	9.2.10	O
Failure-List	9.2.14	O
Channel Indicator	9.2.6	O

This primitive will be sent by the BSC to the CBC in response to a STATUS-MESSAGE-QUERY Request/Indication primitive.

The No-of-Broadcasts-Completed-List, if present, may contain each cell which successfully performed the requested operation and for each of these cells the number of times this CB message has been sent to this particular cell for broadcast (parameter Number-of-Broadcasts-Completed; this parameter is not included for the cell if the old message reference is not known to the BSC, and an entry is made in the failure list). The No-of-Broadcasts-Completed-List will not be present if all cells indicated in the related STATUS-MESSAGE-QUERY Request failed the requested operation.

The Failure-List may contain all cells for which the requested operation failed (e.g. because the broadcast of the requested message was never requested before or because the cells CBCH is not available). The STATUS-MESSAGE-QUERY Response/Confirm will not contain the Failure-List parameter if none of the cells in the Cell-List of the related STATUS-MESSAGE-QUERY Request failed the requested operation.

9.1.9 REJECT Response/Confirm

PARAMETER	REFERENCE	PRESENCE
Cause	9.2.16	M
Diagnostic	9.2.17	O
Message-Identifier	9.2.1	O
Serial Number	9.2.2	O

This primitive is sent by the BSC to the CBC in response to any primitive which is not understood (e.g. invalid parameter or parameter value).

9.1.10 RESTART-INDICATION Request/Indication

PARAMETER	REFERENCE	PRESENCE
Cell-List	9.2.5.2	M
Recovery Indication	9.2.20	O

The RESTART-INDICATION Request is used by the BSC to indicate to the CBC a CB related restart situation in one or more of its cells (e.g. when an existing or a new cell becomes operational during normal BSC operation or when the BSC initialises).

Any referenced cell are again in CB-operational state (have resumed CB operation). The parameter Recovery Indication, if present, indicates whether CB related data are lost for the cells referenced in the Cell-List and have to be re-loaded. If the Recovery Indication parameter is absent, the CBC shall interpret it as the Recovery Indication with the value data lost.

The CBC upon receiving a RESTART INDICATION indication, marks the cell as operational again. It will usually generate WRITE-REPLACE requests for this cell, according to the actual CB message loading at the moment of the restart.

Note that a RESTART INDICATION indication may be triggered from the CBC by a RESET Request. This allows to recover from situations, where a PDU occasionally may be lost.

9.1.11 RESET Request/Indication

PARAMETER	REFERENCE	PRESENCE
Cell-List	9.2.5.1	M

The RESET Request is used by the CBC to force one or more cells (BTSs) of one BSC into CB-idle state.

The RESET Request may also be used by the CBC to ask for the CB operational state of cells earlier indicated to have failed (polling CB operational state).

If a base station controller (BSC) receives a RESET Indication, the indicated cells enter idle state (same state as after "power on"). All CB related information concerning earlier CB messages in a referenced cell is lost.

The BSC acknowledges the RESET Indication for each cell by an RESTART- or, if not adequate, by a FAILURE-INDICATION request.

Of course, several responses may be combined using a cell list in the RESTART or FAILURE INDICATION.

9.1.12 FAILURE-INDICATION Request/Indication

PARAMETER	REFERENCE	PRESENCE
Cell-List	9.2.5.2	M

The FAILURE-INDICATION Request is used by the BSC to indicate to the CBC a CB related problem situation in one or more of its cells.

Any referenced cell enters CB-not-operational state. The status of the CB messages is undefined until the Restart-Indication is sent. It remains in not-operational state until a RESTART-INDICATION request (see 9.1.10) indicates normal CB operation (again).

The CBC upon receiving a FAILURE indication, marks this cell as failed. It will generally not generate further WRITE-REPLACE requests for this cell, up to the point, when the CBC is informed by a RESTART indication, that the cell has resumed CB operation.

The BSC refuses further WRITE-REPLACE requests from the CBC with the cause "cell-broadcast-not-operational" when any referenced cell is in the CB-not-operational state.

Note, that a Failure-Indication may be triggered by a RESET Request. This allows to recover from situations, where a PDU occasionally may be lost.

9.1.13 SET-DRX Request/Indication

PARAMETER	REFERENCE	PRESENCE
Cell-List	9.2.5.1	M
Schedule-Period	9.2.12	O
Reserved-Slots	9.2.13	O
Channel Indicator	9.2.6	O

The SET-DRX Request is used by the CBC to set DRX specific parameters i.e. the schedule period and the number of slots reserved for high priority messages, see GSM 04.12. At least one of the Schedule-Period or Reserved-Slots parameters must be present in the primitive. If this primitive is not supported, the BSC may use default values.

If a base station controller (BSC) receives a SET-DRX Indication, the new DRX parameters will be taken into account starting from the next schedule period in each cell, see GSM 04.12.

If a BSC receives a SET-DRX Indication, the new DRX parameters will be applied for all cells that do not handle any broadcast message (null loading).

9.1.14 SET-DRX- REPORT Response/Confirm

PARAMETER	REFERENCE	PRESENCE
Cell-List	9.2.5.2	O
Failure-List	9.2.14	O
Channel Indicator	9.2.6	O

This primitive will be sent by the BSC to the CBC in response to a SET-DRX Request/Indication primitive.

The Failure-List will contain those cells which were present in the Request message and which failed the requested operation.

If the new schedule period parameters are not acceptable on a cell due to the load of the cell, the cause "bss-capacity-exceeded" is used in the Failure-list.

9.2 Parameters

9.2.1 Message-Identifier

This parameter identifies source/type of message and is passed transparently from the CBC to the MS. Its format is defined in 9.3.2.2.

9.2.2 Old-Serial-Number

This parameter equates to the parameter - Serial Number sent between the BSC and the MS. Its format is defined in 9.3.2.1.

This parameter enables a particular existing message, from the source/type indicated by the message identifier, to be identified.

9.2.3 New-Serial-Number

This parameter equates to the parameter - Serial Number sent between the BSC and the MS. Its format is defined in 9.3.2.1.

This parameter enables message change to be indicated since it is altered every time the message is changed. The serial number identifies a particular message, which may be several pages in length, from the source indicated by the message identifier.

9.2.4 Number-of-Pages

This parameter enables the number of pages in the message to be indicated.

9.2.5 Cell-List

The cell-list identifies a sequence of one or more cells to which the primitives apply.

The cells in the list are described in GSM 08.08 and can be identified by the CBC or BSC in LAC and CI format or CI format only.

In addition (see GSM 08.08) it is possible for the CBC to refer to all cells in a LAC or in a complete BSC. If supplied, the Cell-List parameter must refer to at least one cell.

Given the above differences between cell identification in the two directions, a cell list sent from the CBC to the BSC has a different structure compared to a cell list sent from the BSC to the CBC. The different cell lists are described in sections 9.2.5.1 and 9.2.5.2.

9.2.5.1 Cell-List sent from CBC to BSC

The CBC to BSC Cell-List contains a length parameter identifying the number of cell-identifications present in the list, a Cell-Id-Discriminator, which is common for all cell-identifications in the list, and a sequence of cell-identifications.

Description of list elements:

PARAMETER	PRESENCE
Length	M
Cell-Id-Discriminator	M
Cell-Identification	M

The Cell-Id-Discriminator is described in GSM 08.08 and has one of the following formats:

- LAC and CI;
- CI only;
- all cells in the BSC belonging to a certain Location Area;
- all cells in the BSC.

The Cell-identification is repeated for each cell included in the list. The Cell-List must refer to at least one cell.

9.2.5.2 Cell-List sent from BSC to CBC

The BSC to CBC Cell-List contains a sequence of cell-identifiers as defined in 9.2.11. The Cell-List must contain at least one cell-identifier as defined in 9.2.11.

9.2.6 Channel Indicator

This parameter indicates the CB channel, which shall be used for broadcasting the data.

basic channel;

extended channel (supporting such a channel by the network or MSs is optional);

If no channel indicator is present, it shall be interpreted as an indication to the basic channel.

9.2.7 Category

This indicates the category of the message:

High Priority: to be broadcast at the earliest opportunity in the reserved slots of the current schedule period (i.e. until the emission of the next schedule message), then according to the associated repetition period in the next schedule periods, in non reserved slots.

Background: to be broadcast in the slots left free by messages of category "High Priority" and "Normal", possibly shared with unscheduled schedule messages, see GSM 04.12. The repetition period defines the minimum broadcast requirement.

Normal: to be broadcast according to the associated repetition period.

If the category is omitted, the default category implied is "Normal" message.

9.2.8 Repetition-Period

This indicates the period of time after which broadcast of the message should be repeated. The minimum period with which a message may be broadcast over the air interface is one 8 x 51 multiframe sequence which corresponds to a period of approximately 1.883 seconds.

The value of "Repetition-Period" shall be in the range 1 to 1024 where each unit will represent one 8 x 51 multiframe sequence.

In the event of a conflict where the BSS has more than one message to send at the same time, the BSC shall decide the order of such messages as an implementation matter.

9.2.9 No-of-Broadcasts-Requested

This specifies the number of times the message is to be broadcast. The parameter may take any value up to 65535 (this maximum allows the message to be broadcast approximately every 1.883 seconds for more than 24 hours). If the parameter is set to 0 then the message will be broadcast indefinitely (i.e. until the BSC receives an appropriate Kill-Message Request/Indication primitive).

9.2.10 No-of-Broadcasts-Completed-List

This parameter is a list indicating the number of times that the message (i.e. all pages of the message) has been sent to each Cell in the Cell-List for broadcast over the air interface.

The cells in the list are described as per section 3.2.2.17 of GSM 08.08 and can be identified by LAC and CI or CI only.

Description of list elements:

PARAMETER	PRESENCE
Cell Identifier	M
No-of-Broadcasts-completed	M
No-of-Broadcasts-Compl-Info	O

The information above is repeated for the number of cells in the list.

To each cell in the list the information element No-of-Broadcasts-completed is associated. This information element is related to the particular referenced cell in the list and contains the number of times a CB message (i.e. all pages of a CB message) has been sent to this cell for broadcast. The No-of-Broadcasts-completed information element represents the number of full broadcasts made of a message, and that the message is being (or had been) broadcast.

The optional No-of-Broadcasts-Compl-Info information element may be supplied to indicate to the CBC one of the following cases:

- overflow

the count of the number of full broadcasts made of a message has overflowed, and that the message is being (or had been) broadcast. The actual number of broadcasts completed is greater than the value indicated in the No-of-Broadcasts-completed information element.

- unknown

indicates that there is no information regarding the number of broadcasts completed in the BSC for the message with the old serial number. The value indicated in the No-of-Broadcasts-completed information element is undefined in this case.

The No-of-Broadcasts-Completed-List must contain at least one cell.

9.2.11 Cell-Identifier

The cell-identifier consists of a cell-id-discriminator and cell-identification pair.

Description of list elements:

PARAMETER	PRESENCE
Cell-Id-Discriminator	M
Cell-Identification	M

The Cell-Id-Discriminator is described in GSM 08.08 and has one of the following formats:

- LAC and CI,
- CI only.

The BSC can use the 'LAC and CI' format for a cell identifier in any response to the CBC. The BSC may also use the 'CI only' format for a cell identifier when responding to a CBC primitive that had contained a cell with 'CI only' format for a cell identifier.

9.2.12 Schedule-Period

Indicates the DRX schedule period length, see GSM 04.12.

The following values should be coded:

- no DRX;
- length of the schedule period.

If a schedule period length greater than 40 is used, the schedule message cannot be built entirely if more than 40 messages have to be described in the period. Therefore, schedule period length shall be reduced to 40.

9.2.13 Reserved-Slots

Indicates the number of slots marked as "free slots reading advised" in the schedule message and considered as reserved in a DRX schedule period for incoming high priority messages, not scheduled in the current schedule period, see GSM 04.12.

The spacing of the reserved slots is implementation dependent.

Reserved slots shall receive a 40 value at maximum, taking into account the constraint for schedule period length.

9.2.14 Failure-List

This identifies the list of cells for which the BSC could not complete the request. The failure cause for each cell is indicated. The cells in the list are described as per section 3.2.2.17 of GSM 08.08 and can be identified by LAC and CI or CI only.

Description of list elements:

PARAMETER	PRESENCE
Cell Identifier	M
Cause	M
Diagnostic	O

The information above is repeated for the number of cells that failed.

To each cell in the list the information elements Cause and, as an implementation option, Diagnostic are associated. These are related to the particular referenced cell in the list.

The Failure-List must contain at least one cell.

9.2.15 CBCH-Loading-List

A list of the predicted short term load of each cell in the list expressed as a percentage. The calculation of this percentage is an implementation matter. The load should reflect the number of used slots, and schedule messages and reserved slots must be taken into account. The cells in the list are described in GSM 08.08 and can be identified by LAC and CI or CI only.

Description of list elements:

PARAMETER	PRESENCE
Cell Identifier	M
CBCH-Loading	M

The information above is repeated for the number of cells in the list.

To each cell in the list the information element CBCH-Loading is associated. This information element is related to the particular referenced cell in the list and contains the cells load.

Note that for cells with DRX the load caused by the schedule messages will be included in the CBCH load.

The CBCH-Loading-List must contain at least one cell.

9.2.16 Cause

Indicates reason why the BSC was not able to interpret or execute the received primitive. The causes are given in table 1.

Table 1

Cause	Reason
Parameter-not-recognized	Sent when the recipient (CBC or BSC) was unable to act upon the primitive received due to an unrecognized parameter. A primitive should not be rejected only because a parameter is not recognized as this would prevent extensions to the service
parameter-value-invalid	Sent when a failure occurred due to the value of a parameter being invalid, e.g. out of range, or in Write-Replace, the parameter "no of pages" does not equal the number of pages received
valid-CBS-message-not-identified	Sent when the BSC does not recognize the CBS message reference
cell-identity-not-valid	Sent when the BSC does not recognize a cell Identity
unrecognized-primitive	Sent when the BSC did not recognize the primitive at all
missing-mandatory-element	Sent when a mandatory element is missing from the primitive
bss-capacity-exceeded	Sent when a write-replace fails because the BSC cannot meet the requested repetition period or when the set-drx parameters cannot be applied because of the cell loading
cell-memory-exceeded	Sent when the local cell memory has been exceeded
bss-memory-exceeded	Sent when the BSS is unable to store a message as the BSS memory has been exceeded
cell-broadcast-not-supported	Sent when the CBCH is not configured for a cell
cell-broadcast-not-operational	Sent when the CBCH is not available because of error conditions or due to maintenance activities
incompatible-DRX-parameter	Sent when the DRX parameter(s) cannot be applied.
Extended-channel-not-supported	Sent when a write-replace fails because the extended channel is not configured for a cell
message-reference-already-used	Sent when the recipient (BSC) was unable to act upon the write_replace received due to a previous write_replace received with the same message_reference.
unspecified-error	Sent when none of the above cause values apply

9.2.17 Diagnostic

Provides additional information associated with Cause parameter and may contain parameter which could not be interpreted/executed.

9.2.18 Data Coding Scheme

This parameter identifies the alphabet or coding employed for the message characters and message handling at the MS and is passed transparently from the CBC to the MS. This parameter is defined in GSM 03.38 [3].

9.2.19 CBS-Message-Information-Page n

This parameter is of a fixed length of 82 octets and carries up to and including 82 octets of user information. Where the user information is less than 82 octets, the remaining octets must be filled with padding (see GSM 03.38).

The content of a CBS-Message-Information-Page is passed transparently from the CBC to the MS and becomes the 'Content of Message' parameter at the MS.

In the case where the user information is GSM 7 bit default alphabet encoded, the appropriate padding characters and bit-fill are added to the end of the user information to complete the CBC-Message-Information-Page (see GSM 03.38).

In the case where the user information is 8 bit encoded, the appropriate padding octets are added to the end of the user information to complete the CBS-Message-Information-Page (see GSM 03.38).

9.2.20 CBS-Message-Information-Length n

This parameter gives the number of octets of the CBS-Message-Information-Page n containing user information. The remaining octets of the CBS-Message-Information-Page n contain only padding information and are not included in this parameter.

In the case where the user information is encoded using the GSM 7 bit default alphabet and the last character terminates at an octet boundary, this parameter indicates the number of octets of user information. In the case where the last character does not terminate at an octet boundary, this parameter indicates the number of octets up to the octet boundary immediately following the last GSM 7 bit default alphabet character of user information.

9.2.21 Recovery-Indication

Indicates whether the CBS related data was lost or is still available.

The following values should be coded:

- Data-available;
- Data-lost.

9.3 Message Format on BTS-MS Interface

The messages which are transmitted by the BTS for the MS include the CBS Message (information for the user) and Schedule Message (schedule of CBS messages).

The use and the formatting of the CBS messages, which contain information for the MS user, is described in this section.

The Schedule Message is broadcast to support CBS DRX mode for Mobile Stations. The Schedule Message is helpful in minimizing battery usage for Cell Broadcast in the Mobile Station, because it allows the MS to ignore transmissions of messages the customer is not interested in. The use and formatting of the Schedule Message is described in GSM 04.12.

9.3.1 General Description

Each page of a CBS Message sent to the MS by the BTS is a fixed block of 88 octets as coded in GSM 04.12. This is sent on the channel allocated as CBCH by GSM 05.02. The 88 octets of the CBS Message are formatted as described in 9.3.2.

9.3.2 Message Parameter

Octet Number(s)	Field
1-2	Serial Number
3-4	Message Identifier
5	Data Coding Scheme
6	Page Parameter
7-88	Content of Message

The octets in the above table are transmitted in order, starting with octet 1. The bits within these octets are numbered 0 to 7; bit 0 is the low order bit and is transmitted first.

9.3.2.1 Serial Number

This parameter is a 16-bit integer which identifies a particular message (which may be one to fifteen pages in length) from the source and type indicated by the Message Identifier and is altered every time the message with a given Message Identifier is changed.

The two octets of the Serial Number field are divided into a 2-bit Geographical Scope (GS) indicator, a 10-bit Message Code and a 4-bit Update Number as shown below:

Octet 1								Octet 2							
7	6	5	4	3	2	1	0	7	6	5	4	3	2	1	0
GS		Message Code										Update Number			

The most significant bit of the update number is octet 2 bit 3. The most significant bit of the Message Code is octet 1 bit 5 and the least significant bit of the Message Code is octet 2 bit 4. The most significant bit of the Geographical Scope is octet 1 bit 7.

- Message Code

The Message Code differentiates between messages from the same source and type (i.e. with the same Message Identifier). Message Codes are for allocation by PLMN operators.

The Message Code identifies different message themes. For example, let the value for the Message Identifier be "Automotive Association" (= source), "Traffic Reports" (= type). Then "Crash on A1 J5" could be one value for the message code, "Cow on A32 J4" could be another, and "Slow vehicle on M3 J3" yet another.

- Geographical Scope

The Geographical Scope (GS) indicates the geographical area over which the Message Code is unique, and the display mode. The message is not necessarily broadcast by all cells within the geographical area. When two messages are received with identical Serial Numbers/Message Identifiers in two different cells, the Geographical Scope may be used to determine if the messages are indeed identical.

In particular, the Geographical Scope tells the mobile if the message is only cell wide (which means that any message if received in the next cell is regarded as "new"), or PLMN wide (which means that the Message Code and/or Update Number must change in the next cell for the message to be "new"), or Location Area wide (which means that a message with the same Message Code and Update Number may or may not be "new" in the next cell according to whether the next cell is in the same Location Area as the current cell).

The display mode indicates whether the message is supposed to be on the display all the time ("immediate") or only when the user wants to see it ("normal"). In either case, the message will be displayed only if its Message Identifier is contained within the "search list" of the mobile (see 9.3.2). These display modes are indicative of intended use, without indicating a mandatory requirement or constraining the detailed implementation by mobile manufacturers. The user may be able to select activation of these different modes.

The coding of the Geographical Scope field is shown below:

GS Code	Display Mode	Geographical Scope
00	Immediate	Cell wide
01	Normal	PLMN wide
10	Normal	Location Area wide
11	Normal	Cell wide

Immediate = default direct display

Normal = default display under user interaction

NOTE: Code 00 is intended for use by the network operators for base station IDs.

- Update Number

The Update Number indicates a change of the message content of the same message, i.e. the message with the same Message Identifier, Geographical Scope, and Message Code.

In other words, the Update Number will differentiate between older and newer versions of the same message, within the indicated geographical area. A new message may have Update Number 0000; however this number will increment by 1 for each update. Any Update Number eight or less higher (modulo 16) than the last received Update Number will be considered more recent, and shall be treated as a new message, provided the mobile has not been switched off.

9.3.2.2 Message Identifier

This parameter identifies the source and type of the message. For example, "Automotive Association" (= source), "Traffic Reports" (= type) could correspond to one value. A number of messages may originate from the same source and/or be of the same type. These will be distinguished by the Serial Number. The Message Identifier is coded in binary.

The ME shall attempt to receive the CBS messages whose Message Identifiers are in the "search list". This "search list" shall contain the Message Identifiers stored in the EF_{CBMI}, EF_{CBMID} and EF_{CBMIR} files on the SIM (see GSM 11.11) and any Message Identifiers stored in the ME in a "list of CBS messages to be received". If the ME has restricted capabilities with respect to the number of Message Identifiers it can search for, the Message Identifiers stored in the SIM shall take priority over any stored in the ME.

The use/application of the Message Identifier is shown in the following list, with octet 3 of the Message Identifier shown first, followed by octet 4. Thus "1234" (hex) represents octet 3 = 0001 0010 and octet 4 = 0011 0100.

0000 - 03E7 (hex): To be allocated by PLMN operator associations. If a Message Identifier from this range is in the "search list", the ME shall attempt to receive such message.

This version of GSM 03.41 does not prohibit networks from using Message Identifiers in the range 0000 - 03E7 (hex) for Cell Broadcast Data Download to the SIM.

03E8 (hex) LCS CBS Message Identifier for E-OTD Assistance Data message

03E9 (hex) LCS CBS Message Identifier for DGPS Correction Data message

03EA (hex) LCS CBS Message Identifier for GPS Ephemeris and Clock Correction Data message

03EB (hex): LCS CBS Message Identifier for GPS Almanac and Other Data message

03EC - 0FFF (hex): Intended for standardization in future versions of GSM 03.41. These values shall not be transmitted by networks that are compliant to this version of GSM 03.41. If a Message Identifier from this range is in the "search list", the ME shall attempt to receive this message.

1000 - 107F (hex): Networks shall only use Message Identifiers from this range for Cell Broadcast Data Download in "clear" (i.e. unsecured) to the SIM (see GSM 11.14). If a message Identifier from this range is in the "search list", the ME shall attempt to receive this message.

1080 - 10FF (hex): Networks shall only use Message Identifiers from this range for Cell Broadcast Data Download secured according to GSM 03.48 [15] to the SIM (see GSM 11.14). If a message Identifier from this range is in the "search list", the ME shall attempt to receive this message.

1100 - 9FFF (hex): intended for standardization in future versions of GSM 03.41. These values shall not be transmitted by networks that are compliant to this version of GSM 03.41. If a Message Identifier from this range is in the "search list", the ME shall attempt to receive this message.

A000 - AFFF (hex): PLMN operator specific range. The type of information provided by PLMN operators using these Message Identifiers is not guaranteed to be the same across different PLMNs. If a

Message Identifier from this range is in the "search list", the ME shall attempt to receive this message.

B000 - FFFE (hex): intended as PLMN operator specific range in future versions of GSM 03.41. These values shall not be transmitted by networks that are compliant to this version of GSM 03.41. If a Message Identifier from this range is in the "search list", then the ME shall attempt to receive this message.

FFFF (hex): Reserved, and should not be used for new services, as this value is used on the SIM to indicate that no Message Identifier is stored in those two octets of the SIM. If this Message Identifier is in the "search list", the ME shall attempt to receive this message.

Generally, the MMI for entering these codes in the ME is left to the manufacturers' discretion. However, the 1000 lowest codes shall be capable of being specified via their decimal representation i.e.:

Octet 3	Octet 4	
0000 0000	0000 0000	(decimal '000')
0000 0000	0000 0001	(decimal '001')
0000 0000	0000 0010	(decimal '002')
0000 0000	0000 0011	(decimal '003')
:	:	:
:	:	:
0000 0011	1110 0111	(decimal '999')

9.3.2.3 Data Coding Scheme

This parameter indicates the intended handling of the message at the MS, the alphabet/coding, and the language (when applicable). This is defined in GSM 03.38 [3].

When the SIM indicates one or more language preferences, the ME shall, by default, use the language(s) stored in the SIM (in the EF_{LP} file) to set any language filter mechanisms provided by the ME.

Optionally, the user can select the language(s) required by using an MMI, to determine whether a particular message should be read and displayed.

9.3.2.4 Page Parameter

This parameter is coded as two 4-bit fields. The first field (bits 0-3) indicates the binary value of the total number of pages in the message and the second field (bits 4-7) indicates binary the page number within that sequence. The coding starts at 0001, with 0000 reserved. If a mobile receives the code 0000 in either the first field or the second field then it shall treat the message exactly the same as a message with page parameter 0001 0001 (i.e. a single page message).

9.3.2.5 Content of Message

This parameter is a copy of the 'CBS-Message-Information-Page' as sent from the CBC to the BSC.

9.4 CBS Compression

Cell Broadcast messages may be compressed in accordance with the compression algorithm described in GSM 03.42 [14].

The Data Coding Scheme parameter (see 9.3.2.3) indicates whether or not a CBS Message is compressed.

Compression and decompression may take place between a CBE and an MS or between a CBC and an MS.

The compression applies only to user information sent between the CBC and the MS i.e. excludes any padding octets.

Padding in the case of CBS compression is defined as an integral number of octets where each padding octet has a value FF hexadecimal. The insertion of padding for different scenarios is described in the paragraphs below.

The compression footer (see GSM 03.42) delimits the compressed user information bit stream at an octet boundary. The remainder of the 'CBS-Message-Information-Page' sent between the CBC and the BSC contains padding octets. The parameter 'CBS-Message-Information-Length' identifies the sum of the compressed octets, the compression header, and the compression footer (see GSM 03.42), but not any padding.

Compression may apply to a single 'CBS-Message-Information-Page' or across multiple 'CBS-Message-Information-Page's.

In the case where Compression applies only to a single 'CBS-Message-Information-Page', the compression header shall be the first octet in that 'CBS-Message-Information-Page' and the compression footer shall immediately follow the compressed data stream. Any remaining octets after the compression footer shall contain padding up to and including the 82nd octet position. However, if the 82nd octet position contains the compression footer then there is no padding.

In the case where compression applies across multiple 'CBS-Message-Information-Page's, the compression header shall be present only in the first octet position of the first 'CBS-Message-Information-Page'. The compression footer shall immediately follow the compressed data stream which will terminate within the last 'CBS-Message-Information-Page'. Any remaining octets after the compression footer in the last 'CBS-Message-Information-Page' shall contain padding up to and including the 82nd octet position in the last 'CBS-Message-Information-Page'. However, if the 82nd octet position of the last 'CBS-Message-Information-Page' contains the compression footer then there is no padding.

If it is required to convey different blocks of information which are to be treated by the MS as though they were physically independent pages rather than concatenated information then page break characters (see GSM 03.38) may be inserted in the character stream prior to compression. The boundaries created by the page breaks will not normally align with the boundaries set by the page number parameters and so the page number parameters cannot be used to identify physically separate blocks of meaningful information.

The decoding at the MS may be achieved by first locating the compression footer octet by working back from the 82nd octet in the last 'CBS-Message-Information-Page'. If padding is present, the MS must skip backwards over the padding until a non padding octet is found. By definition this octet must be the compression footer. The compression footer has a pre-defined bit combination which can never replicate a padding octet. If padding is not present in the 82nd octet position of the last 'CBS-Message-Information-Page', by definition the 82nd octet must be the compression footer.

The compression footer defined in GSM 03.42 indicates whether there are any compressed data bits contained within the compression footer octet and, if not, how many compressed data bits are contained within the octet immediately preceding the compression footer. In order to prevent possible replication of the padding octet value in the compression footer octet value, the compression mechanism must ensure that when bits 0,1,2 in the compression footer are all ones all other bits in the compression footer octet are set to 0.

10 CBS Index

An index structure is defined in this section. Index can be used by the operator to inform the end user about the type of CBS services available. Index has the structure of a tree. It can thus have sub parts which are called subindexes. A subindex can be embedded in the same index message as its parent ("embedded subindex") or it can physically be in a separate index message ("child subindex"). Every index message has a unique message identifier. They are always of the same type. Message Code 10101010b shall be used to indicate this type. The root of the index structure shall be the index message with message identifier 0. Other index messages are linked to the root index with links. Definition of their message identifiers is left to the operator.

A format ("enhanced format") for the index messages is described in this section. If this enhanced format is used in the index message the ms can present the index messages in its preferred format.

Available CBS services are introduced in the index. This means that their message identifier and name are stated. Enhanced format includes a mechanism for separating a normal service introduction from embedded subindex introduction and child subindex introduction. The introduction of an embedded subindex specifies the "subindex-id" used for identifying services that belong to this subindex. Embedded subindexes can have subindexes embedded in them etc. If these "second level embedded subindexes" are introduced their subindex-id shall begin with the subindex-id of their parent. Same principle applies for subindexes in third, fourth etc. level. An example of an index structure is given in figure 4.

Enhanced format includes a mechanism which allows the terminals to identify that the format of the index message is enhanced. The index-id -field and the above mentioned Message Code (10101010b) constitute this mechanism:

```

message-format      = index-id index-element-intro+
index-id            = "EI" version crlf
version             = number+
number              = "1" | "2" | "3" | "4" | "5" | "6" | "7" | "8" | "9" | "0"
index-element-intro = subindex-intro | service-intro
subindex-intro     = subindex-id " " subindex-name crlf
subindex-id        = subindex-character+
subindex-character = "a" | "b" | ... | "z" | "A" | "B" | ... | "Z"
subindex-name      = name-character+
name-character     = <gsm03.38character excluding <CR> and <LF> >
crlf                = <CR> <LF>
service-intro      = subindex-id message-id delimiter service-name crlf.
message-id         = number+
delimiter          = "." | " "
service-name       = name-character+

```

Current version used is 1.

The use of "." as delimiter means that this service is a child subindex of the index structure.

Delimiter " " is used in all other cases.

Subindex-id shall not be used if the service introduced is in the first level of the index. Subindex-id:s are used in alphabetical order within an index message. They can be re-used in a child subindex.

0 Index:
(MsgId=0, Message Code = 1010101010b)

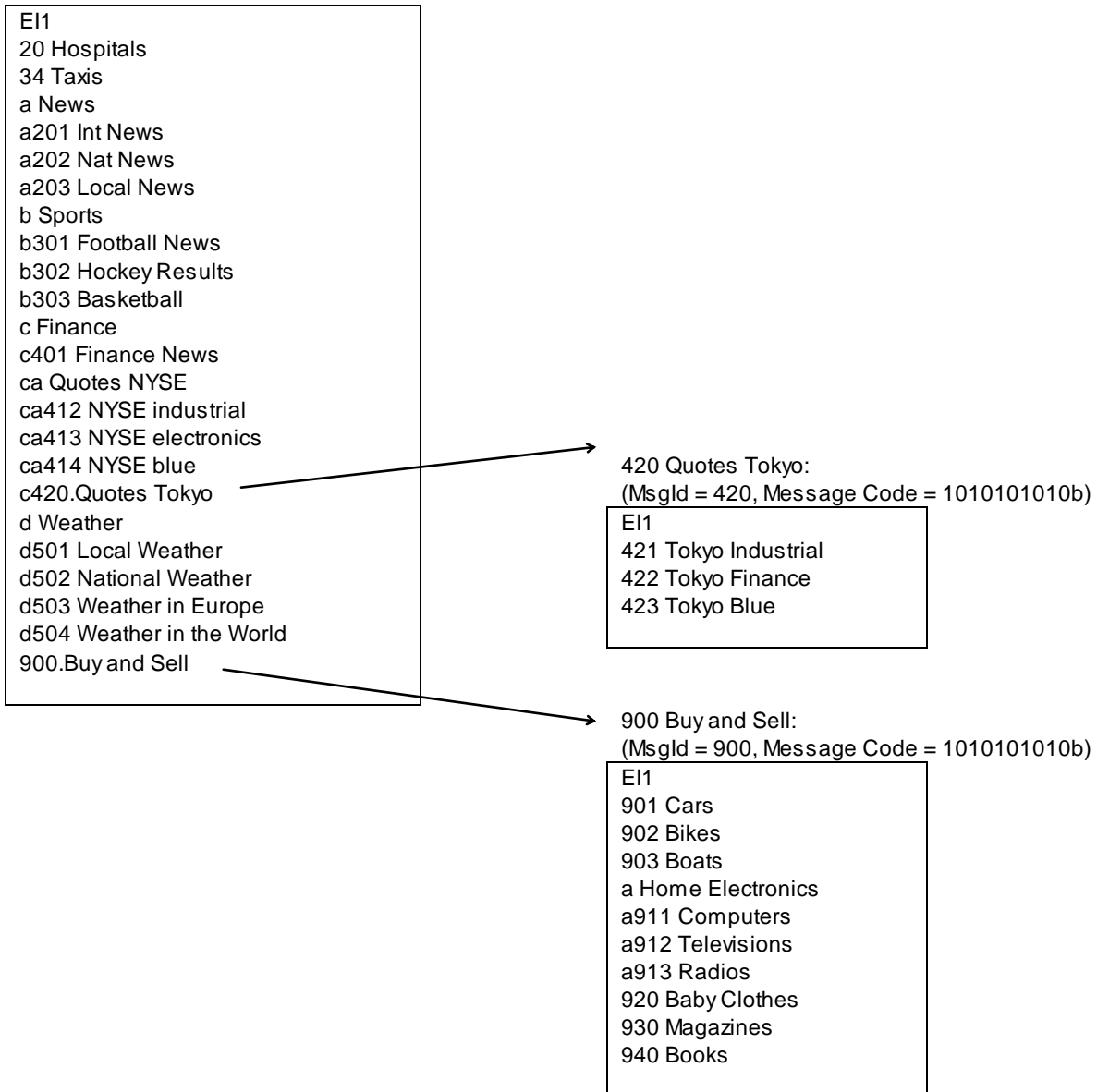

Figure 4

Annex A (informative): Protocols for interconnecting CBC and BSC

No mandatory protocol between the Cell Broadcast Centre (CBC) and the Base Station Controller (BSC) is specified by GSM; this is a matter of agreement between CBC and PLMN operators.

Some example protocols are provided in GSM 03.49 to assist CBC and PLMN operators. These are based on the following principles, which CBC and PLMN operators are recommended to follow even if they choose not to use one of the examples given in GSM 03.49.

The protocol(s) between CBC and BSC should:

- a) provide the service defined for the CBC-BSC interface (see section 9);
- b) be based on protocols normally used for communication between switching and/or computer equipment;
- c) permit open interconnection - preferably using the OSI stack or equivalent (e.g. CCITT Number 7 Stack).

Annex B (informative): Change History

SMG#/ TSG#	CR	PH	VERS	NEW_VERS	SUBJECT
s25	A053	R97	5.8.0	6.0.0	SMSCB Message serial number update
s26	A055	R97	6.0.0	6.1.0	Alignment of 03.41 with 11.11
s28	A056	R98	6.1.0	7.0.0	Editorial clarifications and addition of CBS compression
s28	A057	R98	6.1.0	7.0.0	Reservation and allocation of operator specific message identifiers
s29	A058	R98	7.0.0	7.1.0	Allowing SMS-CB secure Data Download
T#6	A059	R98	7.1.0	7.2.0	LCS Utilization of CBS
T#7	A060	R98	7.2.0	7.3.0	Addition of LCS message identifier to support GPS Navigation message
T#8	A061	R98	7.3.0	7.4.0	Defining Assisted GPS Broadcast Identifiers.