

3GPP TS 02.19 V8.1.0 (2005-06)

Technical Specification

**3rd Generation Partnership Project;
Technical Specification Group Terminals;
Subscriber Identity Module Application Programming
Interface (SIM API);
Stage 1
(Release 1999)**



The present document has been developed within the 3rd Generation Partnership Project (3GPP™) and may be further elaborated for the purposes of 3GPP.

The present document has not been subject to any approval process by the 3GPP Organizational Partners and shall not be implemented.

This Specification is provided for future development work within 3GPP only. The Organizational Partners accept no liability for any use of this Specification.

Specifications and reports for implementation of the 3GPP™ system should be obtained via the 3GPP Organizational Partners' Publications Offices.

Keywords

GSM, SIM, API

3GPP

Postal address

3GPP support office address

650 Route des Lucioles - Sophia Antipolis
Valbonne - FRANCE
Tel.: +33 4 92 94 42 00 Fax: +33 4 93 65 47 16

Internet

<http://www.3gpp.org>

Copyright Notification

No part may be reproduced except as authorized by written permission.
The copyright and the foregoing restriction extend to reproduction in all media.

© 2005, 3GPP Organizational Partners (ARIB, ATIS, CCSA, ETSI, TTA, TTC).
All rights reserved.

ETSI

Contents

Foreword	5
1 Scope	6
2 References	6
2.1 Normative references	6
3 Definitions and abbreviations	6
3.1 Definitions	6
3.2 Abbreviations	7
4 Description	8
4.1 Design of SIM based applications using the SIM API	8
4.2 SIM API Architecture	10
4.3 GSM file data access	11
5 Card Interoperability	11
5.1 Loader Requirements	11
5.2 Application Transport	11
6 Applet triggering	12
7 Applet Life cycle management	12
7.1 Applet Preparation	13
7.2 Loading	13
7.2.1 Arbitration	13
7.2.2 Transport	13
7.2.3 Verification	13
7.2.4 Linking	13
7.3 Installation/Registration/Reactivation	13
7.4 Configuration	14
7.5 Execution	14
7.6 Deactivation	14
7.7 Removal	14
8 Security management	14
8.1 Management of Applets	14
8.2 Applet Certification	14
9 API Compatibility	14
9.1 Level of Compatibility	14
9.2 Compatibility at the Interface	15
9.3 Compatibility at the programming interface	15
9.4 Compatibility with other specifications	15
10 API Extensibility	15
10.1 Evolution of SIM / ME Interface (3GPP TS 11.11)	15
10.2 Evolution of SIM Application Toolkit (3GPP TS 11.14)	15
10.3 Interworking with other systems	15
11 Data and Function Sharing and Access Control	16
11.1 Sharing resources between applets	16
11.2 Access to data	16
12 Technology Considerations	16
12.1 SIM hardware requirements	16
12.2 Technology limitations	16
12.2.1 Memory Recovery	16
12.3 Evolution	17

12.3.1 Remote Procedure Call..... 17

Annex A (Informative): Change History..... 18

Foreword

This Technical Specification has been produced by the 3rd Generation Partnership Project (3GPP).

The contents of the present document are subject to continuing work within the TSG and may change following formal TSG approval. Should the TSG modify the contents of the present document, it will be re-released by the TSG with an identifying change of release date and an increase in version number as follows:

Version x.y.z

where:

- x the first digit:
 - 1 presented to TSG for information;
 - 2 presented to TSG for approval;
 - 3 or greater indicates TSG approved document under change control.
- y the second digit is incremented for all changes of substance, i.e. technical enhancements, corrections, updates, etc.
- z the third digit is incremented when editorial only changes have been incorporated in the document.

1 Scope

This Technical Specification defines the stage one description of the Subscriber Identity Module Application Programming Interface (SIM API) internal to the SIM. Stage one is an overall service description, and does not deal with the implementation details of the API.

This TS includes information applicable to network operators, service providers and terminal, SIM, switch and database manufacturers.

This TS contains the core requirements which are sufficient to provide a complete service.

It is highly desirable however, that technical solutions for a SIM API should be sufficiently flexible to allow for possible enhancements. Additional functionalities not documented in this TS may implement requirements which are considered outside the scope of this TS. This additional functionality may be on a network-wide basis, nation-wide basis or particular to a group of users. Such additional functionality shall not compromise conformance to the core requirements of the service.

2 References

The following documents contain provisions which, through reference in this text, constitute provisions of the present document.

- References are either specific (identified by date of publication, edition number, version number, etc.) or non-specific.
- For a specific reference, subsequent revisions do not apply.
- For a non-specific reference, the latest version applies. In the case of a reference to a 3GPP document (including a GSM document), a non-specific reference implicitly refers to the latest version of that document *in the same Release as the present document*.

2.1 Normative references

- [1] 3GPP TR 21.905: "Vocabulary for 3GPP Specifications".
- [2] 3GPP TS 11.11: "Specification of the Subscriber Identity Module - Mobile Equipment (SIM - ME) interface".
- [3] 3GPP TS 11.14: "Specification of the SIM Application Toolkit for the Subscriber Identity Module - Mobile Equipment (SIM - ME) interface".
- [4] 3GPP TS 03.48: "Security Mechanisms for the SIM application toolkit; Stage 2".
- [5] ISO/IEC 7816-3:1997 "Identification cards - Integrated circuit(s) cards with contacts, Part 3: Electronic signals and transmission protocols".
- [6] ISO/IEC 7816-4 "Identification cards - Integrated circuit, Part 4: Organization, security and commands for interchange".

3 Definitions and abbreviations

3.1 Definitions

For the purposes of this TS the following definitions apply:

Applet: An Applet is an application built up using a number of modules which will run under the control of a virtual machine.

Bytecode: Machine independent code generated by a bytecode compiler and executed by a bytecode interpreter.

Data Structure: A collection of related data values such as the age, birth date and height of an individual.

Framework: A framework defines a set of Application Programming Interface (API) functions and data structures for developing applications and for providing system services to those applications.

Function: A callable and executable body of computer instructions which perform a specific computation or data processing task.

GSM applet: The GSM application conforming to 3GPP TS 11.11.

Module: A collection of functions and data structures which implement an entire application or a particular application feature or capability.

SIM API Framework: Part of the SIM responsible for the handling of applications (including triggering and loading). It also contains the library for the proactive API.

Toolkit applet: Applet loaded onto the SIM seen by the mobile as being part of the SIM Toolkit application and containing only the code necessary to run the application. These applets might be downloaded over the radio interface.

Trusted Party: A trusted party can be described as an entity trusted by the card issuer with respect to security-related services and activities.

Virtual Machine: The part of the Run-time environment responsible for interpreting the bytecode.

3.2 Abbreviations

For the purposes of this TS the following abbreviations apply:

AC	Application Code
AID	Applet IDentifier
APDU	Application Protocol Data Unit
API	Application Programming Interface
AVN	Applet Version Number
CA	Certification Authority
CAD	Card Acceptance Device
CHV1/2	Card Holder Verification information 1 and 2
EEPROM	Electrically Erasable and Programmable Read Only Memory
EPOS	Electronic Point of Sale
FFS	For Further Study
GPRS	General Packet Radio Service
IFD	Interface Device
IN	Intelligent Network
ME	Mobile Equipment
MExE	Mobile Station Execution Environment
MS	Mobile Station
RAM	Random Access Memory
ROM	Read Only Memory
RPC	Remote Procedure Call
SIM	Subscriber Identity Module
SE	Sending Entity
SMS-CB	Short Message Service – Cell Broadcast
SMS P-P	Short Message Service, Point to Point
TAR	Toolkit Application Reference
TLV	Tag, Length, Value
USSD	Unstructured Supplementary Services Data
WAP	Wireless Application Protocol

Further abbreviations are given in TR 21.905 [1].

4 Description

This document describes the high level requirements for an API for the GSM SIM. This API shall allow application programmers easy access to the functions and data described in 3GPP TS 11.11 [2] and 3GPP TS 11.14 [3], such that SIM based services can be developed and loaded onto SIMs, quickly and, if necessarily, remotely, after the card has been issued.

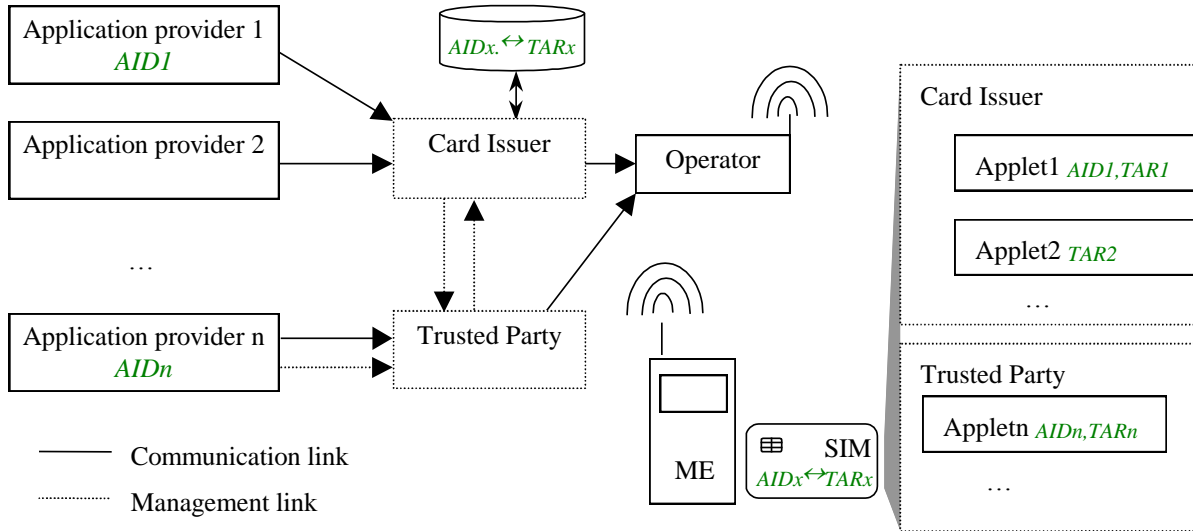

Figure 1: Toolkit applet management and communication

4.1 Design of SIM based applications using the SIM API

Figure 2 shows how SIM applications can be developed in a standard development environment and converted into an interpreted format, then loaded into the card.

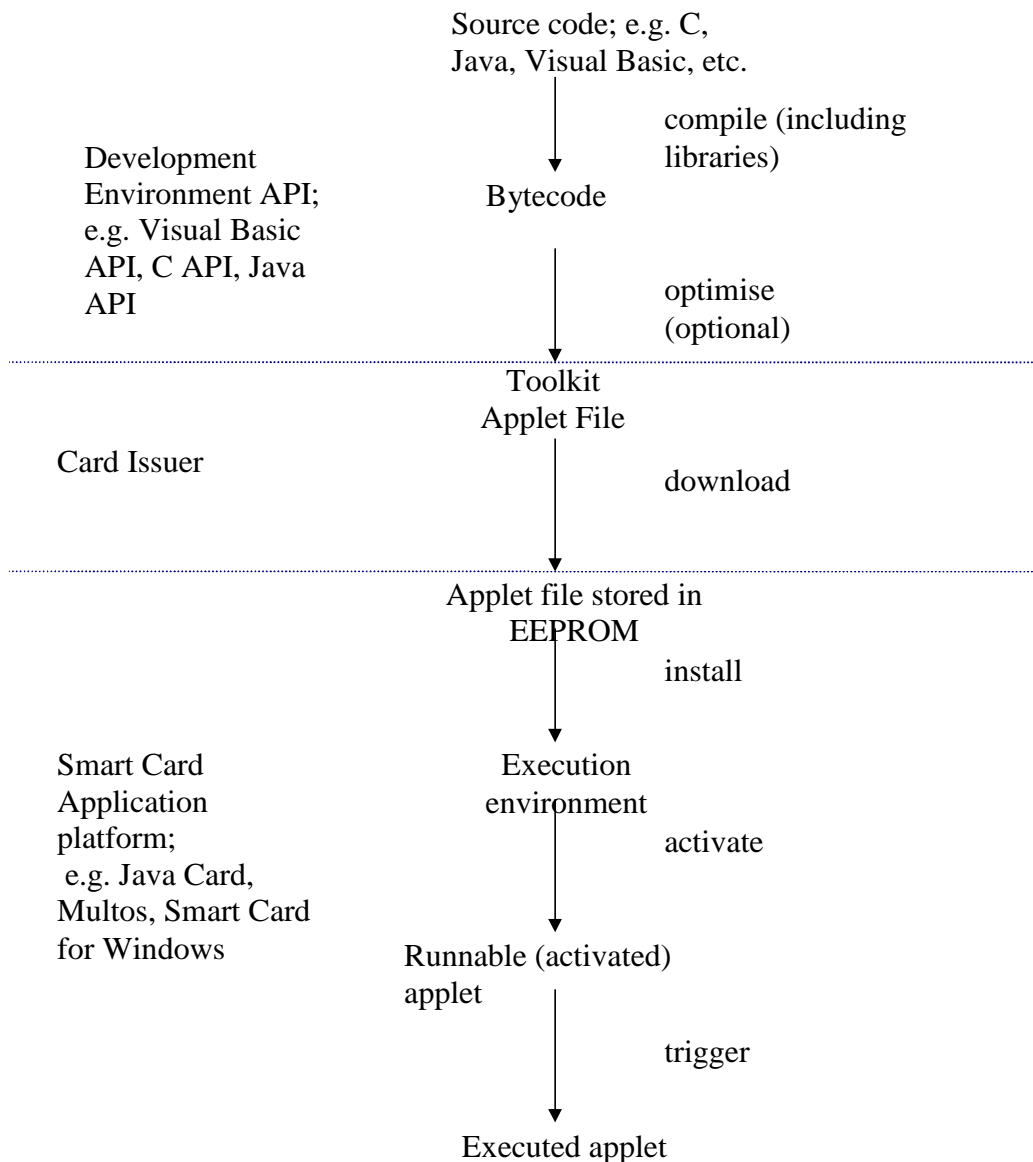

Figure 2: Flow diagram of the development of a SIM application

4.2 SIM API Architecture

The SIM API shall consist of APIs for 3GPP TS 11.14 [3] (pro-active functions) and 3GPP TS 11.11 [2] (transport functions). Figure 3 illustrates the interactions between these APIs.

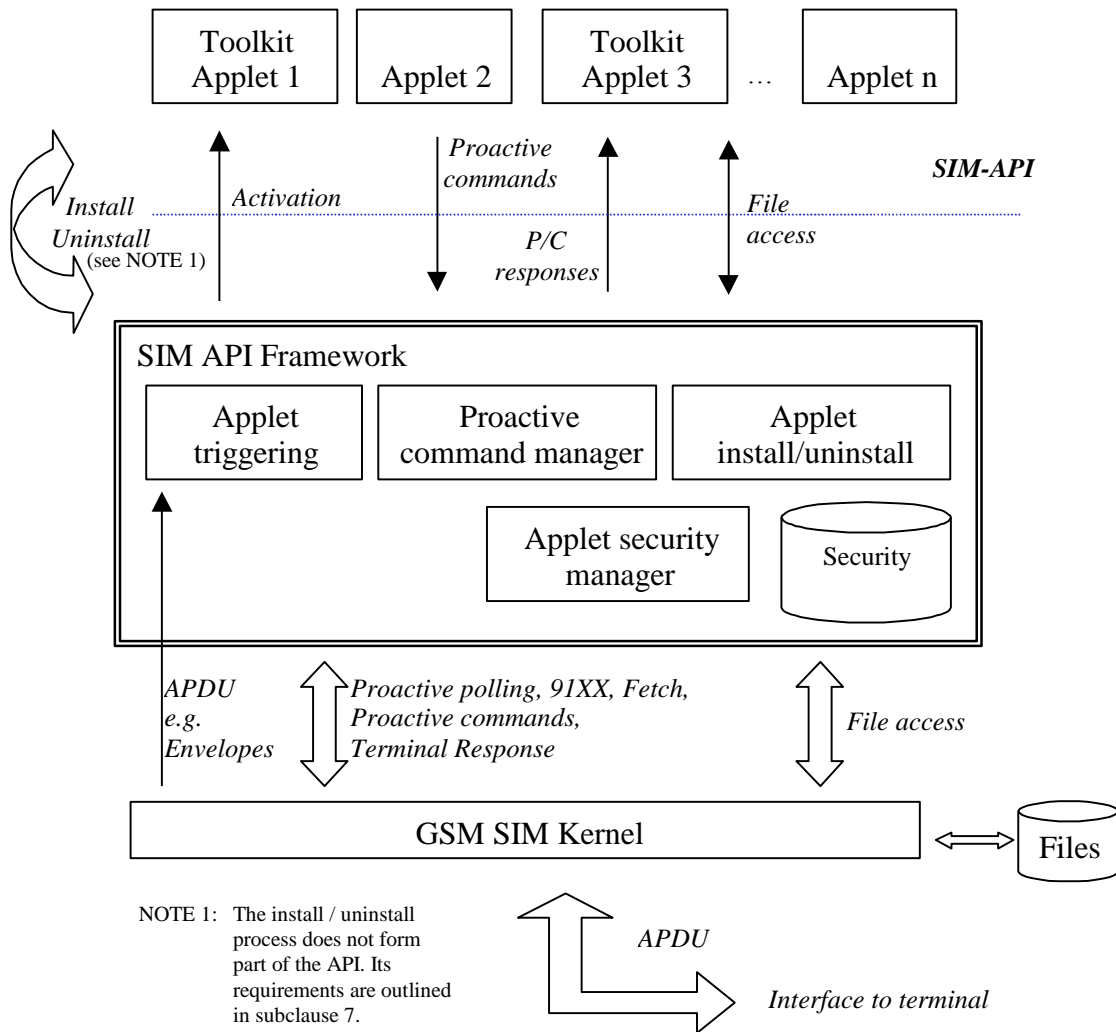

Figure 3: SIM API Architecture

In this model, the GSM data field structure is viewed as a series of data structures and data access functions to the API. In the physical model of course, they may still be stored in elementary files, but the functions will access these data as values within those data structures.

The following figure mirrors the SIM API architecture, relating each part to the appropriate ETSI/GSM or ISO/IEC specification.

Toolkit Applet	Process (A series of instructions requiring Toolkit commands and variables)
SIM API	
3GPP TS 03.48 [4]	Transport Security Mechanisms (e.g. applied to SMS Data download)
3GPP TS 11.14 [3]	TLVs (Built from commands and variables)
3GPP TS 11.11 [2]	Transport of TLVs (Envelope, Fetch, Terminal Response)
	Interaction with data (Other 3GPP TS 11.11 [2] commands)
ISO/IEC 7816-3 [5]	Physical interface (e.g. T=0)

Figure 4: SIM API layers

A general requirement of the SIM API is that applets should not interfere with the basic GSM services.

4.3 GSM file data access

The following methods shall be offered by the SIM Toolkit API:

Select File:	Select a file without changing the current file of any other applet or of the subscriber session. At the beginning of an entry point of an applet, the current file is the MF. This function may return the selected file information;
Status:	Read the file status information of the current DF;
Read Binary:	Read data bytes of a transparent EF;
Read Record:	Read data bytes of a linear fixed or cyclic EF without changing the current record pointer of any other applet / subscriber. This function may allow reading part of a record;
Update Binary:	Modify data bytes to a transparent EF;
Update Record:	Modify data bytes to a linear fixed or cyclic EF. The current record pointer of other applets / subscriber shall not be changed in case of linear fixed EF but the current record of a cyclic EF shall be changed for all other applets / subscriber. This function may allow updating part of a record;
Seek:	Search a record of a linear fixed file starting with a given pattern. The current record pointer of any other applet or of the subscriber session shall not be changed;
Increase:	Increase the value of the current record of a cyclic EF. The current record will be changed for every other applet and subscriber session. This function may not return the increased value;
Rehabilitate:	Rehabilitate the current EF with effect for all other applets / subscriber;
Invalidate:	Invalidate the current EF with effect for all other applets / subscriber.

5 Card Interoperability

5.1 Loader Requirements

There are a number of requirements for the loader which are seen as being vital to the successful deployment of SIM API based SIMs:

- The Applet format shall be common to all compliant SIMs, such that a card issuer can deploy SIM API based service applets to any SIM API compliant SIM.
- The loader environment that allows the loading of applets to the SIM shall be common to all SIM API compliant SIMs. This loader shall be able to send applets to SIMs in three distinct ways:
 - During the personalization of the SIM, prior to the issue of the SIM to the user.
 - During the life of the SIM using the SIM Data Download mechanism defined in 3GPP TS 11.11 [2] and 3GPP TS 03.48 [4] or using other standardized mechanisms in the future.
 - During the life of the SIM using an IFD (Interface Device) or CAD (Card Accepting Device, e.g. an EPOS terminal).

5.2 Application Transport

The transport of applications shall be transparent to the ME. Applications may be transported via several different bearers, e.g. SMS P-P, SMS-CB, USSD, GPRS etc. Transportation of applications to the SIM in a Phase 2+ SIM Application ME shall use the ENVELOPE command as specified in 3GPP TS 11.11 [2].

Other standardized transport commands to the SIM may be developed in the future. Transport commands other than ENVELOPE may be used to transport applets to the SIM if the SIM is not in an ME.

6 Applet triggering.

The application triggering portion of the SIM API Framework is responsible for the activation of applets, based on the APDU received by the GSM application. The inputs and outputs could be represented in the figure below :



Figure 5: Applet Triggering module

Entry points to the applet shall be provided in two ways:

- High level entry points, in order to have a simple programming of the SIM card
- Low level entry points to support the evolution of the 3GPP TS 11.14 [3] specification (see Section 10.2)

Some of the high level entry points are listed below:

- Application Loading
- Application Removal
- Terminal Profile
- Menu Selection
- Short Message Reception
- Cell Broadcast Short Message Reception
- Call Control

7 Applet Life cycle management.

The applet life cycle management concerns the applet preparation, loading, installation, registration, configuration, execution and removal/deactivation.

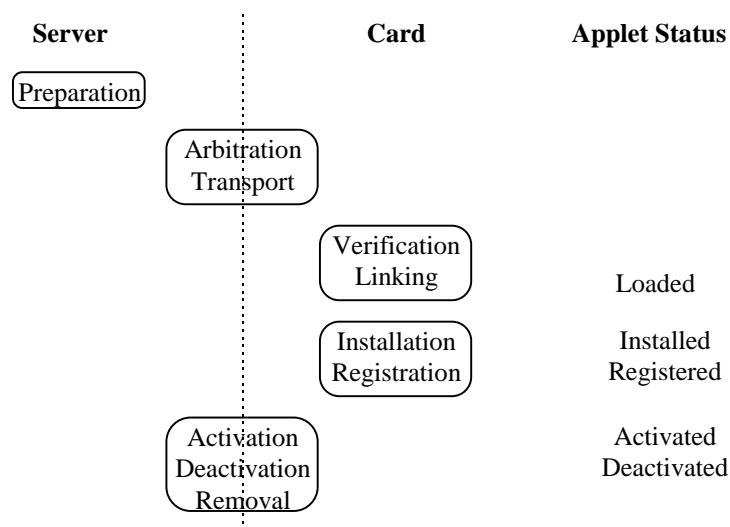

Figure 6: Applet Life Cycle

7.1 Applet Preparation

"Applet Preparation" refers to the optional phase of verifying the compliance of the applet code with card issuer standards.

The applet is to be identified through an Applet Identification Number (AID) which is assigned through the procedure detailed in ISO/IEC 7816-5 [6] and an Applet Version Number (AVN). Both AID and AVN are assigned during the applet preparation phase.

The minimum requirements for the applet (such as API versions, SIM capabilities, resource requirements) shall be specified.

7.2 Loading

"Loading" refers to the process of transporting the applet code from a load server to the SIM and generating the loaded code on the SIM.

The process shall be under the principle control of the card issuer, who may choose to delegate this responsibility to one or more trusted parties, possibly while imposing resource restrictions (e.g. maximum memory allowance) or access restrictions (e.g. limited or reduced functionality).

The loading process involves four distinct phases: Arbitration, Transport, Verification and Linking. The card shall provide acknowledgement of success or failure (including error identification code) to the load server if the load server requires this.

7.2.1 Arbitration

This phase is accomplished by mutual authentication between the SIM and the load server, and by establishing appropriate session keys for ensuring security during the data transfer, which is to follow.

The minimum applet requirements are verified with regard to the environment present on the SIM (e.g. API version, SIM capabilities and available memory). If this fails, the loading process shall be aborted.

The applet identifiers (AIDs) and version numbers (AVNs) of any applets already installed on the SIM are compared to the AID and AVN of the applet, which is to be downloaded. If an identical applet is already installed on the SIM (i.e. both applet identifier and version number match), the phases Transport, Verification and Linking are skipped. If an applet with an identical applet identifier (AID) but different version number (AVN) is available on the SIM, that applet is removed (see subclause 7.7, Removal).

7.2.2 Transport

This stage shall encompass the transport of the data packets from the load server to the SIM, and may be done in accordance with 3GPP TS 03.48 [4] and optionally additional encryption using session keys generated/exchanged during the Arbitration phase.

7.2.3 Verification

This stage shall encompass the verification of the received data and may involve byte-code level or applet-specific verification. Should the verification stage fail, the applet shall be discarded.

7.2.4 Linking

This stage shall encompass the linking of the received code against the runtime environment present on the card.

7.3 Installation/Registration/Reactivation

This stage refers to the execution of applet-code regarding to the installation and registration of the applet with respect to the SIM/ME runtime environment. For example, this may involve the generation of an applet-specific menu entry in the ME's user interface through the appropriate SIM toolkit command, and the generation of applet-specific data structures in SIM memory.

If the applet already exists on the SIM and is deactivated (see subclause 7.6), the installation request shall reactivate the applet. Other methods of reactivation are possible via a separate command.

7.4 Configuration

This stage may involve any necessary configuration of the applet code with regard to a particular user/set-up/environment. This stage is driven through code provided with the applet itself and may be executed repeatedly.

7.5 Execution

At this stage, providing the applet is activated, the applet is in a state where its execution may be triggered by any event as specified in clause 6.

7.6 Deactivation

This stage involves disabling the ability to execute applet code in the SIM and may be triggered by the user, the network operator or any third party, providing sufficient access rights are granted to them. Deactivation may include the release of any applet reserved resources (e.g. memory resources etc.).

7.7 Removal

This stage follows the deactivation of the applet and prevents the applet's reactivation. This may be followed by the release of the applet's memory. For security reasons, the memory may be overwritten by null data.

8 Security management.

8.1 Management of Applets

Security might be required during the loading of the applet from a load server onto the SIM, and the communications between the applet and any remote server during the execution of the applet code. In both cases security may involve the authentication of the communicating entities and the encryption of the data traffic between those entities.

A hierarchy of keys may be bootstrapped by initializing a set of keys by the card issuer during card personalization. Additional keys may be generated, distributed using existing keys, and equipped with limited authority. Such keys may be passed on to trusted parties and subsequently used for authentication and encryption.

8.2 Applet Certification

The role of certification is to ensure that only the authorized entities are able to download an application on to the SIM. Based on this certificate, the card shall decide whether or not to accept the downloaded application.

9 API Compatibility.

9.1 Level of Compatibility

The commands and features supported by the API shall be as specified in the same Release year of 3GPP TS 11.11 [2] and 3GPP TS 11.14 [3].

9.2 Compatibility at the Interface

In order to provide compatibility with the SIM/ME interface, a GSM application SIM implemented using the SIM API shall provide full functional compatibility with the structure and content of 3GPP TS 11.11 [2], 3GPP TS 11.14 [3] commands as specified in those documents. SIM implementing the API shall be compatible with all phases of MEs.

9.3 Compatibility at the programming interface

All commands (at the functional level) shall be presented in a manner consistent with the customary or recommended use of the programming language at the programming level.

The SIM API shall be provided in two ways:

- an easy to use high level interface (proactive commands level), and
- a low level interface (i.e. the TLV parameters) to maximise scope without the need to extend the SIM API.

9.4 Compatibility with other specifications

[TBD e.g. MExE and WAP]

10 API Extensibility

The SIM API shall support applications written for previous versions of the SIM API.

There shall be means to manage versions of the SIM API.

At installation of an applet the required SIM API version shall be checked as described in clause 7.

The ability to extend the SIM API to add functionality may be possible without reissuing the card.

10.1 Evolution of SIM / ME Interface (3GPP TS 11.11)

As the SIM/ME interface is handled by the GSM SIM kernel any evolution of the interface may require the introduction of a new SIM API version.

Older version of the SIM API would still be allowable, but would not have access to the interface enhancement.

10.2 Evolution of SIM Application Toolkit (3GPP TS 11.14)

The SIM API shall provide a low-level interface to support any further releases of 3GPP TS 11.14 [3].

A new version of the SIM API shall provide support for the new features at a high level interface.

10.3 Interworking with other systems

If interworking at APDU and SIM API level with other systems (e.g. MExE, WAP) require some specific functionality, it will first need to be defined either in the 3GPP TS 11.11 [2] or 3GPP TS 11.14 [3], and as a result it will be taken into account in the API specification.

[Administrative command support is currently under discussion within ETSI SMG9]

11 Data and Function Sharing and Access Control.

11.1 Sharing resources between applets

The API shall provide a secure data structure and function sharing mechanism between applets and with the GSM SIM kernel.

The GSM SIM kernel should be able to share with applets:

GSM files : to get file status, read and update data field

CHV1,CHV2 : to get status.

A toolkit applet shall be able to share any kind of data with any other applet even a non-toolkit applet.

The data and function sharing mechanism and the access control management shall be common to all card issuers.

To ease the deployment, these requirements have the following priorities:

high: GSM SIM kernel data sharing (e.g. access to the Telecom directory),

medium: inter industry sharing mechanism between applets.

11.2 Access to data

The SIM API shall provide a way to let each applet indicate:

- the shared data and functions,
- the associated access functions to these data and functions,
- the security or trust level required,
- the accepted certification authorities, and,
- the identity of the applet provider.

The SIM API framework shall check all these parameters before granting an access to data.

12 Technology Considerations.

12.1 SIM hardware requirements

The SIM API requires a smart card device that is capable of implementing a virtual machine and the SIM API framework. It is seen as necessary that there is sufficient EEPROM to contain SIM Applets (either SIM toolkit applications or other SIM applications) along side the mandatory GSM files and potentially many (if not all) of the optional GSM files. The hardware requirements are likely to be:

ROM: minimum 24K Bytes

RAM: minimum 1K Byte

EEPROM: minimum 16K Bytes

12.2 Technology limitations

12.2.1 Memory Recovery

Although there is a requirement for SIM API compliant devices to allow reconfiguration, termination and removal of Applets, it is recognised that SIM API devices may not be fully capable of reclaiming the memory freed up.

12.3 Evolution

12.3.1 Remote Procedure Call

Some current technologies that meet the needs of the SIM API are not designed to allow RPC. Future alternative technologies may be able to support this. It is seen as a future requirement of SIM API when interacting with mobile equipment technologies such as MExE and WAP that RPC is supported.

Annex A (Informative): Change History

This annex lists all change requests approved for the present document.

Change history							
Date	Plenary number	Plenary Doc.	CR	Rev	Subject/Comment	Old	New
1998-10	s27	98-0674			Approved at SMG #27	2.0.0	7.0.0
1999-06	s29	P-99-410	A001		Technology neutrality and implementation independence of specification	7.0.0	7.1.0
2001-06	TP-12				Release 99 version was created automatically after TSG-T #12 to ensure a complete set of specifications for Release 99. There are no technical changes compared to version 7.1.0	7.1.0	8.0.0
2005-06	CP-28	CP-050136	A003		ISO/IEC 7816-series revision	8.0.0	8.1.0