Source: ETSI TC-SMG

Reference: TS/SMG-0010102Q

Key words: Digital cellular telecommunications system, Global System for Mobile communications (GSM)



**Digital cellular telecommunications system (Phase 2+);
General description of a
GSM Public Land Mobile Network (PLMN)
(GSM 01.02)**

ETSI

European Telecommunications Standards Institute

ETSI Secretariat

Postal address: F-06921 Sophia Antipolis CEDEX - FRANCE

Office address: 650 Route des Lucioles - Sophia Antipolis - Valbonne - FRANCE

X.400: c=fr, a=atlas, p=etsi, s=secretariat - **Internet:** secretariat@etsi.fr

Tel.: +33 92 94 42 00 - Fax: +33 93 65 47 16

Copyright Notification: No part may be reproduced except as authorized by written permission. The copyright and the foregoing restriction extend to reproduction in all media.

© European Telecommunications Standards Institute 1996. All rights reserved.

Contents

Foreword.....		5
1	Scope.....	7
	1.1 Normative references	7
	1.2 Abbreviations	16
2	General.....	17
3	Services.....	17
4	System Architecture, Entities And Functions	18
	4.1 The Mobile Station (MS).....	18
	4.2 The Base Station System (BSS).....	19
	4.3 The Mobile-services Switching Centre (MSC)	19
	4.4 The Home Location Register (HLR)	19
	4.5. The Visitor Location Register (VLR).....	19
	4.6. Group Call Register (GCR)	21
	4.7. Operation and Maintenance Centre (OMC).....	21
	4.8. System architecture, interworking and interfaces	21
5	Subsystems of a GSM PLMN.....	22
	5.1 The Base Station System (BSS).....	22
	5.2 The Switching and Management Subsystems (SMSS).....	24
	5.3 Operation and maintenance subsystem	26
6	Other aspects	26
	6.1 Signalling.....	27
	6.2 Transmission plan	27
	6.3 Technical description of services and facilities	27
	6.4 Coding aspects and information processing	27
	6.5 Interworking	27
	History	30

Blank page

Foreword

This Global System for Mobile communications Technical Specification (GTS) has been produced by the Special Mobile Group (SMG) Technical Committee (TC) of the European Telecommunications Standards Institute (ETSI).

This GTS specifies GSM Public Land Mobile Network (PLMN). It contains a definition and a summarised description of the elements comprised in the network, and their functions and the associated performance objectives within the digital cellular telecommunications system (Phase 2/Phase 2+).

This GTS is a TC-SMG approved GSM technical specification version 5, which contains GSM Phase 2+ enhancements/features to the version 4 GSM technical specification. The ETS from which this Phase 2+ GTS has evolved is Phase 2 GSM ETR 99 (GSM 01.02 version 4.0.1).

GTS are produced by TC-SMG to enable the GSM Phase 2+ specifications to become publicly available, prior to submission for the formal ETSI standards approval procedure to become European Telecommunications Standards (ETS). This ensures the earliest possible access to GSM Phase 2+ specifications for all Manufacturers, Network operators and implementors of the Global System for Mobile communications.

The contents of this GTS are subject to continuing work within TC-SMG and may change following formal TC-SMG approval. Should TC-SMG modify the contents of this GTS it will then be republished by ETSI with an identifying change of release date and an increase in version number as follows:

Version 6.x.y

where:

- 6 indicates Release 1997 of GSM Phase 2+
- y the third digit is incremented when editorial only changes have been incorporated in the specification;
- x the second digit is incremented for all other types of changes, i.e. technical enhancements, corrections, updates, etc.

The specification from which this GTS has been derived was originally based on CEPT documentation, hence the presentation of this GTS may not be entirely in accordance with the ETSI rules.

Reference is made within this GTS to GSM-TSs (note).

NOTE: TC-SMG has produced documents which give the technical specifications for the implementation of the digital cellular telecommunications system. Historically, these documents have been identified as GSM Technical Specifications (GSM-TSs). These TSs may have subsequently become I-ETSS (Phase 1), or ETSs/ETSI Technical Reports (ETRs) (Phase 2). TC-SMG has also produced ETSI GSM TSs which give the technical specifications for the implementation of Phase 2+ enhancements of the digital cellular telecommunications system. These version 6.x.x GSM Technical Specifications may be referred to as GTSSs.

Blank page

1 Scope

The present document gives a general description of a GSM Public Land Mobile Network (PLMN). It contains a definition and a summarised description of the elements comprised in the network, and their functions and the associated performance objectives. The services and facilities that the network can offer to its users, are also described as well as the general lines of signalling procedures, operation and maintenance.

Since the present document includes information spread throughout all GSM specifications this document can serve as guide.

The terms "GSM MoU" and "PCN MoU" (or sometimes "MoU" only) used in this document refers to Operators' organisations implementing GSM and to which some responsibility of referred-to documents belong.

1.1 Normative references

This GTS incorporates by dated and undated reference, provisions from other publications. These normative references are cited at the appropriate places in the text and the publications are listed hereafter. For dated references, subsequent amendments to or revisions of any of these publications apply to this GTS only when incorporated in it by amendment or revision. For undated references, the latest edition of the publication referred to applies.

- [1] GSM 01.04 (ETR 100): "Digital cellular telecommunication system (Phase 2); Abbreviations and acronyms".
- [2] GSM 02.01 (ETS 300 500): "Digital cellular telecommunication system (Phase 2); Principles of telecommunication services supported by a GSM Public Land Mobile Network (PLMN)".
- [3] GSM 02.02 (ETS 300 501): "Digital cellular telecommunication system (Phase 2); Bearer Services (BS) supported by a GSM Public Land Mobile Network (PLMN)".
- [4] GSM 02.03 (ETS 300 502): "Digital cellular telecommunication system (Phase 2); Teleservices supported by a GSM Public Land Mobile Network (PLMN)".
- [5] GSM 02.04 (ETS 300 503): "Digital cellular telecommunication system (Phase 2); General on supplementary services".
- [6] GSM 02.06 (ETS 300 504): "Digital cellular telecommunication system (Phase 2); Types of Mobile Stations (MS)".
- [7] GSM 02.07 (ETS 300 505): "Digital cellular telecommunication system (Phase 2); Mobile Station (MS) features".
- [8] GSM 02.09 (ETS 300 506): "Digital cellular telecommunication system (Phase 2); Security aspects".
- [9] GSM 02.11 (ETS 300 507): "Digital cellular telecommunication system (Phase 2); Service accessibility".
- [10] GSM 02.16 (ETS 300 508): "Digital cellular telecommunication system (Phase 2); International Mobile station Equipment Identities (IMEI)".
- [11] GSM 02.17 (ETS 300 509): "Digital cellular telecommunication system (Phase 2); Subscriber identity modules Functional characteristics".
- [12] GSM 02.24 (ETS 300 510): "Digital cellular telecommunication system (Phase 2); Description of Charge Advice Information (CAI)".

- [13] GSM 02.30 (ETS 300 511): "Digital cellular telecommunication system (Phase 2); Man-Machine Interface (MMI) of the Mobile Station (MS)".
- [14] GSM 02.40 (ETS 300 512): "Digital cellular telecommunication system (Phase 2); Procedures for call progress indications".
- [15] GSM 02.41 (ETS 300 513): "Digital cellular telecommunication system (Phase 2); Operator determined barring".
- [16] GSM 02.67: "Digital cellular telecommunication system (Phase 2+); enhance Multi-Level Precedence and Pre-emption service (eMLPP) - Stage 1".
- [17] GSM 02.68: "Digital cellular telecommunication system (Phase 2+); Voice Group Call service (VGCS) - Stage 1".
- [18] GSM 02.69: "Digital cellular telecommunication system (Phase 2+); Voice Broadcast Service (VBS) - Stage 1".
- [19] GSM 02.81 (ETS 300 514): "Digital cellular telecommunication system (Phase 2); Line identification supplementary services - Stage 1".
- [20] GSM 02.82 (ETS 300 515): "Digital cellular telecommunication system (Phase 2); Call Forwarding (CF) supplementary services - Stage 1".
- [21] GSM 02.83 (ETS 300 516): "Digital cellular telecommunication system (Phase 2); Call Waiting (CW) and Call Hold (HOLD) supplementary services - Stage 1".
- [22] GSM 02.84 (ETS 300 517): "Digital cellular telecommunication system (Phase 2); MultiParty (MPTY) supplementary services - Stage 1".
- [23] GSM 02.85 (ETS 300 518): "Digital cellular telecommunication system (Phase 2); Closed User Group (CUG) supplementary services - Stage 1".
- [24] GSM 02.86 (ETS 300 519): "Digital cellular telecommunication system (Phase 2); Advice of charge (AoC) supplementary services - Stage 1".
- [25] GSM 02.88 (ETS 300 520): "Digital cellular telecommunication system (Phase 2); Call Barring (CB) supplementary services - Stage 1".
- [26] GSM 03.01 (ETS 300 521): "Digital cellular telecommunication system (Phase 2); Network functions".
- [27] GSM 03.02 (ETS 300 522): "Digital cellular telecommunication system (Phase 2); Network architecture".
- [28] GSM 03.03 (ETS 300 523): "Digital cellular telecommunication system (Phase 2); Numbering, addressing and identification".
- [29] GSM 03.04 (ETS 300 524): "Digital cellular telecommunication system (Phase 2); Signalling requirements relating to routing of calls to mobile subscribers".
- [30] GSM 03.05 (ETR 102): "Digital cellular telecommunication system (Phase 2); Technical performance objectives".
- [31] GSM 03.07 (ETS 300 525): "Digital cellular telecommunication system (Phase 2); Restoration procedures".
- [32] GSM 03.08 (ETS 300 526): "Digital cellular telecommunication system (Phase 2); Organisation of subscriber data".

- [33] GSM 03.09 (ETS 300 527): "Digital cellular telecommunication system (Phase 2); Handover procedures".
- [34] GSM 03.10 (ETS 300 528): "Digital cellular telecommunication system (Phase 2); GSM Public Land Mobile Network (PLMN) connection types".
- [35] GSM 03.11 (ETS 300 529): "Digital cellular telecommunication system (Phase 2); Technical realization of supplementary services".
- [36] GSM 03.12 (ETS 300 530): "Digital cellular telecommunication system (Phase 2); Location registration procedures".
- [37] GSM 03.13 (ETS 300 531): "Digital cellular telecommunication system (Phase 2); Discontinuous Reception (DRX) in the GSM system".
- [38] GSM 03.14 (ETS 300 532): "Digital cellular telecommunication system (Phase 2); Support of Dual Tone Multi-Frequency signalling (DTMF) via the GSM system".
- [39] GSM 03.15 (ETS 300 533): "Digital cellular telecommunication system (Phase 2); Technical realization of operator determined barring".
- [40] GSM 03.20 (ETS 300 534): "Digital cellular telecommunication system (Phase 2); Security related network functions".
- [41] GSM 03.22 (ETS 300 535): "Digital cellular telecommunication system (Phase 2); Functions related to Mobile Station (MS) in idle mode".
- [42] GSM 03.30 (ETR 103): "Digital cellular telecommunication system (Phase 2); Radio network planning aspects".
- [43] GSM 03.40 (ETS 300 536): "Digital cellular telecommunication system (Phase 2); Technical realization of the Short Message Service (SMS) Point to Point (PP)".
- [44] GSM 03.41 (ETS 300 536): "Digital cellular telecommunication system (Phase 2); Technical realization of Short Message Service Cell Broadcast (SMSCB)".
- [45] GSM 03.43 (ETR 104): "Digital cellular telecommunication system (Phase 2); Support of Videotex".
- [46] GSM 03.44 (ETR 105): "Digital cellular telecommunication system (Phase 2); Support of teletex in a GSM Public Land Mobile Network (PLMN)".
- [47] GSM 03.45 (ETS 300 538): "Digital cellular telecommunication system (Phase 2); Technical realization of facsimile group 3 transparent".
- [48] GSM 03.46 (ETS 300 539): "Digital cellular telecommunication system (Phase 2); Technical realization of facsimile group 3 non-transparent".
- [49] GSM 03.46] (ETR 106): "Digital cellular telecommunication system (Phase 2); Example protocol stacks for interconnecting Service Centre(s) (SC) and Mobile-services Switching Centre(s) (MSC)".
- [50] GSM 03.49 (ETR 106): "Digital cellular telecommunication system (Phase 2); Example protocol stacks for interconnecting Cell Broadcast Centre (CBC) and Mobile-services Switching Centre (MSC)".
- [51] GSM 03.50 (ETS 300 540): "Digital cellular telecommunication system (Phase 2); Transmission planning aspects of the speech service in the GSM Public Land Mobile Network (PLMN) system".

- [52] GSM 03.67: "Digital cellular telecommunication system (Phase 2+); enhance Multi-Level Precedence and Pre-emption service (eMLPP) - Stage 2".
- [53] GSM 03.68: "Digital cellular telecommunication system (Phase 2+); Voice Group Call service (VGCS) - Stage 2".
- [54] GSM 03.69: "Digital cellular telecommunication system (Phase 2+); Voice Broadcast Service (VBS) - Stage 2".
- [55] GSM 03.6]0 (ETS 300 541): "Digital cellular telecommunication system (Phase 2); Routing of calls to/from Public Data Networks (PDN)".
- [56] GSM 03.81 (ETS 300 542): "Digital cellular telecommunication system (Phase 2); Line identification supplementary services - Stage 2".
- [57] GSM 03.82 (ETS 300 543): "Digital cellular telecommunication system (Phase 2); Call Forwarding (CF) supplementary services - Stage 2".
- [58] GSM 03.83 (ETS 300 544): "Digital cellular telecommunication system (Phase 2); Call Waiting (CW) and Call Hold (HOLD) supplementary services - Stage 2".
- [59] GSM 03.84 (ETS 300 545): "Digital cellular telecommunication system (Phase 2); MultiParty (MPTY) supplementary services - Stage 2".
- [60] GSM 03.85 (ETS 300 546): "Digital cellular telecommunication system (Phase 2); Closed User Group (CUG) supplementary services - Stage 2".
- [61] GSM 03.86 (ETS 300 546): "Digital cellular telecommunication system (Phase 2); Advice of Charge (AoC) supplementary services - Stage 2".
- [62] GSM 03.88 (ETS 300 548): "Digital cellular telecommunication system (Phase 2); Call Barring (CB) supplementary services - Stage 2".
- [63] GSM 03.90 (ETS 300 549): "Digital cellular telecommunication system (Phase 2); Unstructured supplementary services operation - Stage 2".
- [64] GSM 04.01 (ETS 300 550): "Digital cellular telecommunication system (Phase 2); Mobile Station - Base Station System (MS - BSS) interface General aspects and principles".
- [65] GSM 04.02 (ETS 300 551): "Digital cellular telecommunication system (Phase 2); GSM Public Land Mobile Network (PLMN) access reference configuration".
- [66] GSM 04.03 (ETS 300 552): "Digital cellular telecommunication system (Phase 2); Mobile Station - Base Station System (MS - BSS) interface Channel structures and access capabilities".
- [67] GSM 04.04 (ETS 300 553): "Digital cellular telecommunication system (Phase 2); layer 1 General requirements".
- [68] GSM 04.05 (ETS 300 554): "Digital cellular telecommunication system (Phase 2); Data Link (DL) layer General aspects".
- [69] GSM 04.06 (ETS 300 555): "Digital cellular telecommunication system (Phase 2); Mobile Station - Base Station System (MS - BSS) interface Data Link (DL) layer specification".
- [70] GSM 04.06] (ETS 300 556): "Digital cellular telecommunication system (Phase 2); Mobile radio interface signalling layer 3 General aspects".

- [71] GSM 04.08 (ETS 300 556): "Digital cellular telecommunication system (Phase 2); Mobile radio interface layer 3 specification".
- [72] GSM 04.10 (ETS 300 558): "Digital cellular telecommunication system (Phase 2); Mobile radio interface layer 3 Supplementary services specification General aspects".
- [73] GSM 04.11 (ETS 300 559): "Digital cellular telecommunication system (Phase 2); Point-to-Point (PP) Short Message Service (SMS) support on mobile radio interface".
- [74] GSM 04.12 (ETS 300 560): "Digital cellular telecommunication system (Phase 2); Short Message Service Cell Broadcast (SMSCB) support on the mobile radio interface".
- [75] GSM 04.13 (ETS 300 561): "Digital cellular telecommunication system (Phase 2); Performance requirements on mobile radio interface".
- [76] GSM 04.21 (ETS 300 562): "Digital cellular telecommunication system (Phase 2); Rate adaption on the Mobile Station - Base Station System (MS - BSS) interface".
- [77] GSM 04.22 (ETS 300 563): "Digital cellular telecommunication system (Phase 2); Radio Link Protocol (RLP) for data and telematic services on the Mobile Station - Base Station System (MS - BSS) interface and the Base Station System - Mobile-services Switching Centre (BSS - MSC) interface".
- [78] GSM 04.80 (ETS 300 564): "Digital cellular telecommunication system (Phase 2); Mobile radio interface layer 3 supplementary services specification Formats and coding".
- [79] GSM 04.81 (ETS 300 565): "Digital cellular telecommunication system (Phase 2); Line identification supplementary services - Stage 3".
- [80] GSM 04.82 (ETS 300 566): "Digital cellular telecommunication system (Phase 2); Call Forwarding (CF) supplementary services - Stage 3".
- [81] GSM 04.83 (ETS 300 566): "Digital cellular telecommunication system (Phase 2); Call Waiting (CW) and Call Hold (HOLD) supplementary services - Stage 3".
- [82] GSM 04.84 (ETS 300 568): "Digital cellular telecommunication system (Phase 2); MultiParty (MPTY) supplementary services - Stage 3".
- [83] GSM 04.85 (ETS 300 569): "Digital cellular telecommunication system (Phase 2); Closed User Group (CUG) supplementary services - Stage 3".
- [84] GSM 04.86 (ETS 300 56]0): "Digital cellular telecommunication system (Phase 2); Advice of Charge (AoC) supplementary services - Stage 3".
- [85] GSM 04.88 (ETS 300 56]1): "Digital cellular telecommunication system (Phase 2); Call Barring (CB) supplementary services - Stage 3".
- [86] GSM 04.90 (ETS 300 56]2): "Digital cellular telecommunication system (Phase 2); Unstructured supplementary services operation - Stage 3".
- [87] GSM 05.01 (ETS 300 56]3): "Digital cellular telecommunication system (Phase 2); Physical layer on the radio path General description".

- [88] GSM 05.02 (ETS 300 56]4): "Digital cellular telecommunication system (Phase 2); Multiplexing and multiple access on the radio path".
- [89] GSM 05.03 (ETS 300 56]5): "Digital cellular telecommunication system (Phase 2); Channel coding".
- [90] GSM 05.04 (ETS 300 56]6): "Digital cellular telecommunication system (Phase 2); Modulation".
- [91] GSM 05.05 (ETS 300 56]6): "Digital cellular telecommunication system (Phase 2); Radio transmission and reception".
- [92] GSM 05.08 (ETS 300 56]8): "Digital cellular telecommunication system (Phase 2); Radio subsystem link control".
- [93] GSM 05.10 (ETS 300 56]9): "Digital cellular telecommunication system (Phase 2); Radio subsystem synchronisation".
- [94] GSM 05.90 (ETR 108): "Digital cellular telecommunication system (Phase 2); GSM Electro Magnetic Compatibility (EMC) considerations".
- [95] GSM 06.01 (ETS 300 580-1): "Digital cellular telecommunication system (Phase 2); Full rate speech processing functions".
- [96] GSM 06.10 (ETS 300 580-2): "Digital cellular telecommunication system (Phase 2); Full rate speech transcoding".
- [97] GSM 06.11 (ETS 300 580-3): "Digital cellular telecommunication system (Phase 2); Substitution and muting of lost frames for full rate speech channels".
- [98] GSM 06.12 (ETS 300 580-4): "Digital cellular telecommunication system (Phase 2); Comfort noise aspect for full rate speech traffic channels".
- [99] GSM 06.31 (ETS 300 580-5): "Digital cellular telecommunication system (Phase 2); Discontinuous Transmission (DTX) for full rate speech traffic channel".
- [100] GSM 06.32 (ETS 300 580-6): "Digital cellular telecommunication system (Phase 2); Voice Activity Detection (VAD)".
- [101] GSM 06.02 (ETS 300 581-1): "Digital cellular telecommunication system (Phase 2); Half rate speech processing functions".
- [102] GSM 06.20 (ETS 300 581-2): "Digital cellular telecommunication system (Phase 2); Half rate speech transcoding".
- [103] GSM 06.21 (ETS 300 581-3): "Digital cellular telecommunication system (Phase 2); Substitution and muting of lost frames for half rate speech traffic channels".
- [104] GSM 06.22 (ETS 300 581-4): "Digital cellular telecommunication system (Phase 2); Comfort noise aspects for half rate speech traffic channels".
- [105] GSM 06.41 (ETS 300 581-5): "Digital cellular telecommunication system (Phase 2); Discontinuous Transmission (DTX) for half rate speech traffic channels".
- [106] GSM 06.42 (ETS 300 581-6): "Digital cellular telecommunication system (Phase 2); Voice Activity Detection (VAD) for half rate speech traffic channels".

- [107] GSM 06].01 (ETS 300 582): "Digital cellular telecommunication system (Phase 2); General on Terminal Adaptation Functions (TAF) for Mobile Stations (MS)".
- [108] GSM 06].02 (ETS 300 583): "Digital cellular telecommunication system (Phase 2); Terminal Adaptation Functions (TAF) for services using asynchronous bearer capabilities".
- [109] GSM 06].03 (ETS 300 584): "Digital cellular telecommunication system (Phase 2); Terminal Adaptation Functions (TAF) for services using synchronous bearer capabilities".
- [110] GSM 06].06 (ETS 300 586): "Digital cellular telecommunication system (Phase 2); Use of the V series Data Terminal Equipment - Data Circuit terminating Equipment (DTE - DCE) interface at the Mobile Station (MS) for Mobile Termination (MT) configuration".
- [111] GSM 06].06] (ETS 300 642): "Digital cellular telecommunication system (Phase 2); AT Command set for GSM Mobile Equipment (ME)".
- [112] GSM 08.01 (ETS 300 586]-1): "Digital cellular telecommunication system (Phase 2); Base Station System - Mobile services Switching Centre (BSS - MSC) interface General aspects".
- [113] GSM 08.02 (ETS 300 586]-2): "Digital cellular telecommunication system (Phase 2); Base Station System - Mobile-services Switching Centre (BSS - MSC) interface Interface principles".
- [114] GSM 08.04 (ETS 300 588): "Digital cellular telecommunication system (Phase 1); Base Station System - Mobile-services Switching Centre (BSS - MSC) interface Layer 1 specification".
- [115] GSM 08.06 (ETS 300 589): "Digital cellular telecommunication system (Phase 2); Signalling transport mechanism specification for the Base Station System - Mobile-services Switching Centre (BSS - MSC) interface".
- [116] GSM 08.08 (ETS 300 590): "Digital cellular telecommunication system (Phase 2); Mobile Switching Centre - Base Station System (MSC - BSS) interface Layer 3 specification".
- [117] GSM 08.20 (ETS 300 591): "Digital cellular telecommunication system (Phase 2); Rate adaption on the Base Station System - Mobile-services Switching Centre (BSS - MSC) interface".
- [118] GSM 08.51 (ETS 300 592): "Digital cellular telecommunication system (Phase 2); Base Station Controller - Base Transceiver Station (BSC - BTS) interface General aspects".
- [119] GSM 08.52 (ETS 300 593): "Digital cellular telecommunication system (Phase 2); Base Station Controller - Base Transceiver Station (BSC - BTS) interface Interface principles".
- [120] GSM 08.54 (ETS 300 594): "Digital cellular telecommunication system (Phase 2); Base Station Controller - Base Transceiver Station (BSC - BTS) interface Layer 1 structure of physical circuits".
- [121] GSM 08.56 (ETS 300 595): "Digital cellular telecommunication system (Phase 2); Base Station Controller - Base Transceiver Station (BSC - BTS) interface Layer 2 specification".

- [122] GSM 08.58 (ETS 300 596): "Digital cellular telecommunication system (Phase 2); Base Station Controller - Base Transceiver Station (BSC - BTS) interface Layer 3 specification".
- [123] GSM 08.60 (ETS 300 596): "Digital cellular telecommunication system (Phase 2); Inband control of remote transcoders and rate adaptors".
- [124] GSM 08.61 (ETS 300 598): "Digital cellular telecommunication system (Phase 2); Inband control of remote transcoders and rate adaptors (half rate)".
- [125] GSM 09.01 (ETR 109): "Digital cellular telecommunication system (Phase 2); General network interworking scenarios".
- [126] GSM 09.02 (ETS 300 599): "Digital cellular telecommunication system (Phase 2); Mobile Application Part (MAP) specification".
- [127] GSM 09.03 (ETS 300 600): "Digital cellular telecommunication system (Phase 2); Signalling requirements on interworking between the Integrated Services Digital Network (ISDN) or Public Switched Telephone Network (PSTN) and the Public Land Mobile Network (PLMN)".
- [128] GSM 09.04 (ETS 300 601): "Digital cellular telecommunication system (Phase 2); Interworking between the Public Land Mobile Network (PLMN) and the Circuit Switched Public Data Network (CSPDN)".
- [129] GSM 09.05 (ETS 300 602): "Digital cellular telecommunication system (Phase 2); Interworking between the Public Land Mobile Network (PLMN) and the Packet Switched Public Data Network (PSPDN) for Packet Assembly/Disassembly facility (PAD) access".
- [130] GSM 09.06 (ETS 300 603): "Digital cellular telecommunication system (Phase 2); Interworking between a Public Land Mobile Network (PLMN) and a Packet Switched Public Data Network/Integrated Services Digital Network (PSPDN/ISDN) for the support of packet switched data transmission services".
- [131] GSM 09.06] (ETS 300 604): "Digital cellular telecommunication system (Phase 2); General requirements on interworking between the Public Land Mobile Network (PLMN) and the Integrated Services Digital Network (ISDN) or Public Switched Telephone Network (PSTN)".
- [132] GSM 09.09 (ETR 110): "Digital cellular telecommunication system (Phase 2); Detailed signalling interworking within the Public Land Mobile Network (PLMN) and with the Public Switched Telephone Network/Integrated Services Digital Network (PSTN/ISDN)".
- [133] GSM 09.10 (ETS 300 605): "Digital cellular telecommunication system (Phase 2); Information element mapping between Mobile Station - Base Station System and BSS - Mobile-services Switching Centre (MS - BSS - MSC) Signalling procedures and the Mobile Application Part (MAP)".
- [134] GSM 09.11 (ETS 300 606): "Digital cellular telecommunication system (Phase 2); Signalling interworking for supplementary services".
- [135] GSM 09.90 (ETR 111): "Digital cellular telecommunication system (Phase 2); Interworking between Phase 1 infrastructure and Phase 2 Mobile Stations (MS)".
- [136] GSM 11.10 (ETS 300 606): "Digital cellular telecommunication system (Phase 2); Mobile Station (MS) conformity specification".

- [137] GSM 11.11 (ETS 300 608): "Digital cellular telecommunication system (Phase 2); Specification of the Subscriber Identity Module - Mobile Equipment (SIM - ME) interface".
- [138] GSM 11.20 (ETS 300 609): "Digital cellular telecommunication system (Phase 2); The GSM Base Station System (BSS) equipment specification".
- [139] GSM 11.40 (ETS 300 610): "Digital cellular telecommunication system (Phase 2); System Simulator (SS) specification".
- [140] GSM 11.50 (ETS 300 611): "Digital cellular telecommunication system (Phase 2); Test equipment for type approval of Mobile Stations (MS) operating in the 1800 MHz band (DCS 1800)".
- [141] GSM 12.00 (ETS 300 612-1): "Digital cellular telecommunication system (Phase 2); Objectives and structure of Network Management (NM)".
- [142] GSM 12.01 (ETS 300 612-2): "Digital cellular telecommunication system (Phase 2); Common aspects of GSM Network Management (NM)".
- [143] GSM 12.06] (ETS 300 612-3): "Digital cellular telecommunication system (Phase 2); Operations and performance management".
- [144] GSM 12.02 (ETS 300 613): "Digital cellular telecommunication system (Phase 2); Subscriber, Mobile Equipment (ME) and services data administration".
- [145] GSM 12.03 (ETS 300 614): "Digital cellular telecommunication system (Phase 2); Security management".
- [146] GSM 12.04 (ETS 300 615): "Digital cellular telecommunication system (Phase 2); Performance data measurements".
- [147] GSM 12.05 (ETS 300 616): "Digital cellular telecommunication system (Phase 2); Subscriber related event and call data".
- [148] GSM 12.06 (ETS 300 616): "Digital cellular telecommunication system (Phase 2); GSM Network change control".
- [149] GSM 12.10 (ETS 300 618): "Digital cellular telecommunication system (Phase 2); Maintenance provisions for operational integrity of Mobile Stations (MS)".
- [150] GSM 12.11 (ETS 300 619): "Digital cellular telecommunication system (Phase 2); Maintenance of the Base Station System (BSS)".
- [151] GSM 12.13 (ETS 300 620): "Digital cellular telecommunication system (Phase 2); Maintenance of the Mobile-services Switching Centre (MSC)".
- [152] GSM 12.14 (ETS 300 621): "Digital cellular telecommunication system (Phase 2); Maintenance of location registers".
- [153] GSM 12.20 (ETS 300 622): "Digital cellular telecommunication system (Phase 2); Network Management (NM) procedures and messages".
- [154] GSM 12.21 (ETS 300 623): "Digital cellular telecommunication system (Phase 2); Network Management (NM) procedures and message on the A-bis interface".
- [155] GSM 12.22 (ETS 300 624): "Digital cellular telecommunication system (Phase 2); Interworking of GSM Network Management (NM) procedures and messages at the Base Station Controller (BSC)".

[156] CCITT Recommendation M.30: "Principles for a telecommunications management network".

1.2 Abbreviations

Abbreviations used in the ETS are listed in GSM 01.04.

2 General

The general objectives of a GSM PLMN network are:

- regarding aspects of service to users:
 - * to give users a wide range of services and facilities, both voice and non voice, that are compatible with those offered by fixed networks (PSTN, ISDN and PDNs) through standardized access to these networks.
 - * give certain services and facilities exclusive to mobile situations.
 - * give compatibility of access to the GSM network to any mobile subscriber in any country of the CEPT who operates the GSM system.
 - * give facilities for automatic roaming, locating and updating mobile subscribers.
 - * give subscribers a service with a good quality level.
 - * give service to a wide range of mobile stations, including vehicle mounted stations, portable stations and handheld stations.

- regarding performance aspects:
 - * give high efficiency from the radioelectrical spectrum.
 - * allow an attractive economic cost in terms of both infrastructure and mobile equipment.

The vocabulary used in the GSM Specifications is detailed in GSM 01.04.

3 Services

A GSM PLMN provides the user with a wide range of services and facilities that, aside from some that are specific to mobile situations, make use of access to other existing networks (fixed telephone networks, data networks and Integrated Services Digital Network).

The characteristics of the telecommunications services offered (that are characterised by a series of attributes and values), the network capacities required for them, and the modelling method used, are described in GSM 02.01.

A telecommunication service supported by the GSM PLMN is defined as a group of communication capabilities that the Operator of the network places at the disposal of its users.

The introduction phases of the various services are under control of GSM/PCN MoU.

The Telecommunication Services provided by the GSM PLMN are divided into two main groups, called Basic Services:

- Bearer Services, which are Telecommunication Services that give the user the capacity needed to transmit appropriate signals between certain access points (user-network interfaces).
- Teleservices, which are Telecommunication Services that provide the user with necessary capacities including terminal equipment functions, to communicate with any other users.

Supplementing and/or modifying the Basic Services (Bearer Services and Teleservices), the Supplementary Services complete the offer to the user.

Bearer Services are described in GSM 02.02, Teleservices in GSM 02.03, and Supplementary Services in GSM 02.04 and the GSM 02.80 series. An overview of the Basic services is given in Tables 1 and 2.

Possibilities for alternate and/or simultaneous use of telecommunications services exist and may be offered by GSM operators.

Those aspects related to security required due to the use of the radio channel used for the system, are described in GSM 02.09. The implementation of these elements in the system, and their implications for the network, are found in GSM 03.20.

Since this is a network which uses a radio interface, the procedures through which the subscribers have access to the services offered are standardised. GSM 02.11 covers these aspects from the point of view of the subscriber. Technical aspects related to access to services (register, handover, roaming, etc.) appear in the GSM 03-Series of specifications.

The Pan-European concept of the system makes standardization of accounting mechanisms absolutely essential. Aspects related to billing information, transferred account and international accounting are covered by the GSM/PCN MoU.

Aspects related to the supplementary service, Advice of Charge are covered in GSM 02.24.

All the services and facilities offered by the GSM system require the support of certain network capabilities. The network features related to call progress information are described in GSM 02.40.

To facilitate simplicity of use by the subscriber, it is vitally important to have appropriate man-machine interfaces. GSM 02.30 specifies requirements and gives guidelines for the man-machine interface for calls.

The nature of the system offers the subscriber the possibility of moving freely through countries where a GSM PLMN is operated. To guarantee access to services offered to subscribers, agreements are needed between the various Network Operators.

The capabilities for Operator Determined Barring of Calls is defined in GSM 02.41.

4 System Architecture, Entities And Functions

In order for the system to support the services and facilities described in the previous section, a series of functions are required. The description of the network functions, procedures and the interworking between PLMN's, are covered in GSM 03.01. Those network functions that specifically cover aspects of network security are found in GSM 03.20.

Various generic aspects found in any telecommunication network, especially a GSM PLMN, such as: numbering, identification and routing; signalling required to route calls from a fixed network to a mobile subscriber; technical performance objectives that the fixed part of the GSM network must comply with, are found respectively in GSM 03.03, GSM 03.04, GSM 03.05 and GSM 03.70.

The functions referred to in previous paragraphs of this section, are grouped into functional entities. The complete system, in turn, is formed by a number of these functional entities. Figure 1 shows the functional entities of the system and their logical interconnections. 03.02 covers formal definitions of these entities and aspects related to the same.

4.1 The Mobile Station (MS)

The mobile station (MS) consists of the physical equipment used by the subscriber to a GSM PLMN to gain access to the telecommunications services offered. Functionally it includes a Mobile Termination (MT) and, depending on the services it can support, various Terminal Equipment (TE), and combinations of Terminal Equipment (TE) and Terminal Adaptor (TA) functions (see TSs GSM 03.45, 03.46, 07.01, 07.02 and 07.03). The configurations are described in GSM 04.02.

There are various types of MS, described in GSM 02.06, such as: vehicle mounted stations, portable stations or handheld stations. The specific aspect of the man-machine interface are covered in GSM 02.30.

The features that the MS may contain are described in GSM 02.07.

A mobile station has a number of identities. First as all equipment, it has an International Mobile Equipment Identity (IMEI) which is described in GSM 02.16 and GSM 03.03. When used by a subscriber, it carries the International Mobile Subscriber Identity (IMSI) - described in GSM 03.03 - which is embodied in the Subscriber Identity Module (SIM) described in GSM 02.17.

4.2 The Base Station System (BSS)

The Base Station System (BSS) is the physical equipment used to give radio coverage to a determined geographical zone called a cell, and to contain the equipment needed to communicate with MS. Functionally, a BSS is subdivided in turn into a control function carried out by the base station controller (BSC) and a radio transmitting function carried out by the base transmitter station (BTS). The specification for the equipment forming the BSS is found in GSM 11.20. In GSM 08 series of specifications are found the definitions and specifications for the interfaces between the various components of the BSS.

4.3 The Mobile-services Switching Centre (MSC)

The Mobile Service Switching Centre (MSC) is a switching centre that holds all the switching functions needed for mobiles located in an associated geographical area, called an MSC area.

A Mobile Service Switching Centre takes into account the mobile nature of its subscribers and manages the necessary radio resources, especially those procedures required to handle and update the location registration procedure described in GSM 03.12 and procedures required to carry out the handover described in GSM 03.09.

Interworking with other networks (PSTN for example) needs the presence of specific functions associated with the MSC; known as interworking functions (IWF). The IWF's depend on the type of network with which it is desired to interconnect and the type of service desired. Interworking functions are described in GSM 09.04, GSM 09.05 GSM 09.06 and GSM 09.07, with the corresponding interworking signalling with PSTN-ISDN found in GSM 09.09.

4.4 The Home Location Register (HLR)

The Home Location Register (HLR) is a data base used for the management of mobile subscribers. The number of them in a PLMN varies according to the characteristics of the PLMN itself.

Two types of basic information are stored in the HLR:

- Subscriber information
- part of the mobile location information allowing incoming calls to be routed to the MSC for the said mobile.

The organisation of subscriber data appears in GSM 03.08.

Any administrative action by the Network Operator on subscriber data is carried out in the HLR.

The Home Location Register stores three identities essential to the system:

- The International Mobile subscriber Identity (IMSI) (described in GSM 03.03).
- The Mobile station ISDN Number
- The VLR address (see following section: VLR).

4.5 The Visitor Location Register (VLR)

The VLR is the functional unit that dynamically stores subscriber information, such as location area, when the subscriber is located in the area this VLR is in charge of. When a roaming mobile enters an MSC area, this MSC warns the associated VLR of this situation; the mobile enters a registration procedure through

which it is assigned a mobile subscriber roaming number (MSRN) or visited network address that serves to route incoming calls to that mobile.

The VLR also contains other information needed to handle incoming/outgoing calls. This information is gathered by the VLR via a dialogue with the HLR associated with the mobile subscriber.

- Mobile Station Roaming Number.
- Temporary Mobile Subscriber Identity, if applicable
- The location area in which the mobile has been registered.
- Data related to supplementary service parameters.

The description of the procedure for the exchange of information between VLR and HLR appears in GSM 03.12.

4.6. Group Call Register (GCR)

The GCR is a functional unit in the network containing all attributes needed for set-up and handling of voice group and broadcast calls. These include the group call membership list, priority entitlements, network information etc.. The attributes are assigned at registration time and stored in the GCR.

When a voice group or broadcast call initiated, the originating MSC will interrogate the GCR for the parameters needed to set-up the call. The description of voice group and broadcast call set-up procedures can be found in detail in GSM 03.68 [53] and GSM 03.69 [54] respectively.

4.7. Operation and Maintenance Centre (OMC)

The Operation and Maintenance Centre is the functional entity through which the Network Operator can monitor and control the system. A general description of the structure and objectives of the maintenance network associated with a PLMN are found in GSM 12.00 and 12.01. The rest of the operation and maintenance functions for the various interfaces and entities making up the system are described in the rest of the GSM 12 series.

4.8. System architecture, interworking and interfaces

Some of the network architectures that can be obtained with the functional elements described above are shown in GSM 03.02.

The figure 1 show these entities and their interconnection.

To achieve optimum working between different units forming the system, the corresponding interfaces are required. The use of the signalling system No7 (SS7) in particular between MSC-VLR and MSC-HLR, allows the possibility of transmitting both call control signals and other information. The corresponding transmission capabilities must be supported by the Mobile Application Part (MAP) defined in GSM 09.02.

A general description of the different interfaces needed in a GSM PLMN appears in GSM 03.02. The interface is defined in the GSM 04 series of specifications, relative to layers 1, 2 and 3, while the 05 series of specifications cover jointly the specific transmission aspects of the radio path.

A GSM PLMN should be able to interwork with other networks. A description of the various interworking cases that arise are covered in GSM 09.01. The remaining specifications in the 09 series cover interworking conditions between a PLMN and other networks in general, detailing in GSM 09.11 the signalling interworking needed to guarantee enjoyment of supplementary services by users.

5 Subsystems of a GSM PLMN

The description of the system based on its functional elements, describing both its function and the interrelation between the elements, give a broad overall view of the system itself. A higher level of understanding can be achieved if a study is undertaken dividing it into subsystems. A subsystem is an entity composed of one or more physical equipment to carry out a specific task. The union of these specific activities achieves the intended operation of the GSM PLMN.

The subsystems mentioned above are:

- The Base Station System (BSS)
- The Switching and Management Subsystem (SMSS)
- The Operation and Maintenance Subsystem (OMSS).

5.1 The Base Station System (BSS)

The base station system includes the functions of the physical layer according to the Reference Model for the Open Systems Interconnection of ISO/CCITT, both in the mobile station (MS) and the base station System (BSS).

The base station system is composed of a number of logical channels. The structuring criteria for the logical channels and their access capabilities are covered in GSM 04.03.

The base station system has two types of channels:

- * Traffic channels (TCH)
- * Signalling channels

The traffic channels are used to transmit user data or coded speech and are in turn divided into two channel types, Bm or full rate (TCH/F) and Lm or half-rate channels (TCH/H). Together the base station system may support traffic channels as described in GSM 05.03

The signalling channels are divided in turn in broadcast control channels (BCCH); common control channel (CCCH); stand-alone dedicated control channel (SDCCH) and associated control channel (ACCH). (An associated control channel is always associated with each TCH or SDCCH).

As a group, the base station system has the following signalling channels:

- Stand-alone dedicated control channel, four of them mapped on the same basic physical channel as the CCCH (SDCCH/4).
- Stand-alone dedicated control channel, eight of them mapped on the separate basic physical channel (SDCCH/8).
- Full-rate fast associated control channel (FACCH/F)
- Half-rate fast associated control channel (FACCH/H)
- Slow TCH/F associated control channel (SACCH/TH)
- Slow TCH/H associated control channel (SNCCH/TF)
- Slow SDCCH/4 associated control channel (SACCH/C4)
- Slow SDCCH/8 associated control channel (SDCCH/C8)
- Broadcast control channel (BCCH)
- Random access channel (RACH)

- Paging channel (PCH)
- Access grant channel (AGCH)

The transmission of information on signalling channels is carried out in a structure of blocks and frames defined in GSM 05.02. Logical channels mentioned above are grouped in physical channels whose organization appears in the same specification.

The access method is Time Division Multiple Access (TDMA) with 8/16 basic channels (defined as a sequence of TDMA frames, a time slot number in module 8, and a frequency hopping sequence) per carrier. The separation between channels is 200 KHz.

Other aspects related to the radio system appear more in 05 series specifications:

GSM 05.02: Definition of physical channels in the radio subsystem and the description and multiplexing of logical channels. It also defined frequency hopping, TDMA frames, time slots and burst.

GSM 05.03: Description encoding, reordering, interleaving.

GSM 05.04: Description of the RF modulation needed in the system.

GSM 05.05: Description of the requirements of the transceiver of the GSM system.

Finally, the performance and synchronization aspects of the radio subsystem appear in GSM 05.07, GSM 05.08 and GSM 05.10, respectively.

An overview of all the specifications of the 05 series appears in GSM 05.01.

5.2 The Switching and Management Subsystems (SMSS)

The Switching and Management Subsystem (SMSS) is the subsystem in which are included all the functions required to handle signalling protocols, by which calls are established, maintained and cleared. It should be noted that because of the mobile nature of the subscribers, the Switching and Management Subsystem must be able to control and handle certain specific functions for the mobile environment.

The main functions of this subsystem are:

- Specific functions related to the mobile nature of subscribers regarding the handling of calls: e.g. paging.
- Management of radio resources during a call.
- Management of the signalling protocol with the BSS.
- Location registration: interworking with the VLR.
- The hand-over procedure: connection with another BSS in the same or different MSC area within the same PLMN when a mobile moves during a call.
- Interrogation of the HLR to obtain the MS roaming number and the MS location.
- Exchange of signalling information with other mobile functional entities (VLR, HLR, GCR or other MSCs).
- Management of call set-up for voice group calls, broadcast calls and enhanced Multi-Level Precedence and Pre-emption (eMLPP) service.
- Authentication of the subscriber.

Other specific aspects of the SMSS are numbering and addressing.

Aspects related to numbering, in the overall sense, are found in GSM 03.03/03.09/03.70; GSM 08.08; GSM 09.02/09.03/09.04/09.05/09.06/09.07.

Aspects related to voice group calls, voice broadcast calls and eMLPP services are found GSM 02.67 [16], 02.68 [17], 02.69 [18] , 03.67 [52], 03.68 [53] and 03.69 [54].

5.3 Operation and maintenance subsystem

The handling of the features related to system security, based on the validation of identities of the various Telecommunication entities, are carried out by:

- Authentication Centre(s) (AUC)

This is in charge of providing the authentication key used for authorizing the subscriber access to the associated GSM PLMN.

- Equipment Identity Register(s) (EIR)

This is in charge of handling Mobile Station Equipment Identity included with each Mobile Station.

The subsystem is in charge of remote operations and maintenance of the PLMN. Control functions are monitored and controlled in the Operations and Maintenance Centre (OMC).

To centralize PLMN control, one or more Network Management Centres (NMC) can be installed.

In relation to operation and maintenance aspects there is the underlying concept of TMN: Telecommunication Management Network, defined by the CCITT in Recommendation M.30.

In this context, operations for which the OMC is responsible are defined as all those actions of a technical and/or administrative nature that may be needed due to changes in external conditions (demands for services, etc.).

Following the same line, maintenance is understood as all those technical and/or administrative actions (including supervisory actions) intended to maintain the system operating correctly or restore normal operation after a breakdown in one of its parts, in the shortest possible time.

The following Network Management Functions can be specifically identified (carried out through the corresponding OMC's).

- 1) Functions related to administrative or commercial management of the PLMN:
 - subscribers
 - terminals
 - billing
 - accounting
 - statistics
- 2) Security management
- 3) Operations and performance management
- 4) System change control
- 5) Maintenance

In GSM 12.00 are found the definitions, references and general structures that make up the Operation and Maintenance Subsystem, the "modus operandi" appears in GSM 12.01. Operation and maintenance aspects for the various functional entities composing a PLMN are covered in GSM 12.10. The remaining aspects relating to the Operation and Maintenance Centre are described in GSM 12.02/12.07.

6 Other aspects

Described in this section are concrete aspects of the system that, although mentioned in previous sections, merit specific treatment because of their importance.

6.1 Signalling

Signalling used in the GSM system consists of two very different parts. The first is a specific system signal at levels 1, 2 and 3 and is applied to the radio path MS-BTS.

The rest of the signalling in the system is based on the pertinent CCITT Recommendations (Signalling system No7). The various interfaces between MS and BS are described in the GSM 04 series.

6.2 Transmission plan

The transmission plan drawn up in GSM 03.50 covers two basic parts of voice services. The first of them proposes certain network configurations, giving information on the parameter reference values to be taken into account for connections to achieve a determined service quality. The second part refers to transmission performance, giving the essential characteristics to be complied with between the mobile interface and the PLMN, and between the latter and the PSTN.

GSM 03.50 defines in general terms the interfaces: radio interface, PLMN-PSTN connection interface and MSC-MSC connection interface. Also covered here are generic reference values for different parameters intervening in transmission/reception (delays, losses, etc.).

6.3 Technical description of services and facilities

The description of the services and facilities provided by the system is given in the specifications mentioned in section 2. However, the technical description which involves not only specific parameters of the service itself, but other overall ones for the system are described in separate specification.

Supplementary services are described in GSM 02.04 (general description) and 02.8x-series, while technical realizations are given in GSM 03.11 (gen.) and 03.8x-series. Advance speech call items such as Voice Group Call, Voice Broadcast Call and enhanced Multi-Level Precedence and Pre-emption (eMLPP) are described in GSM 02.67 [16], GSM 02.68 [17], GSM 02.69 [18], GSM 03.67 [52], GSM 03.68 [53] and GSM 03.69 [54].

The rest of the 03 series of describe the technical aspects of other services. Particularly, GSM 03.30 give the general basis for the planning of a radio network for the system, a key part of the implementation of a GSM PLMN.

6.4 Coding aspects and information processing

The functions that must be carried out by the Speech Codec within the system, are described in GSM 06.01. The rest of 06 series covers other aspects related to speech coding.

The adaptation aspects of terminals in mobile stations (MSs) needed to use the telecommunications service provided by the system, are described and detailed in GSM 04.21 and in the 05 and 07 series of the GSM specifications.

6.5 Interworking

Interworking of the GSM PLMN network with other telecommunication networks, is covered by 09 series of the GSM specification.

Table 1: Teleservices

Telephony
Emergency Calls
Short Message Mobile Terminated Point-to-Point
Short Message Mobile Originated Point-To-Point
Short Message Cell Broadcast
Alternate Speech and Facsimile Group 3
Automatic Facsimile Group 3
Voice Group Call Service
Voice Broadcast Service

Table 2: Bearer Services

Data Circuit Duplex Asynchronous 300 - 9600 bit/s (T/NT)
Data Circuit Duplex Synchronous 1200 - 9600 bit/s (T/NT)
PAD Access Circuit Asynchronous 300 - 9600 bit/s (T/NT)
Data Packet Duplex Synchronous 2400 - 9600 bit/s (T/NT)
Alternate Speech/Data (T/NT)
Speech followed by Data (T/NT)

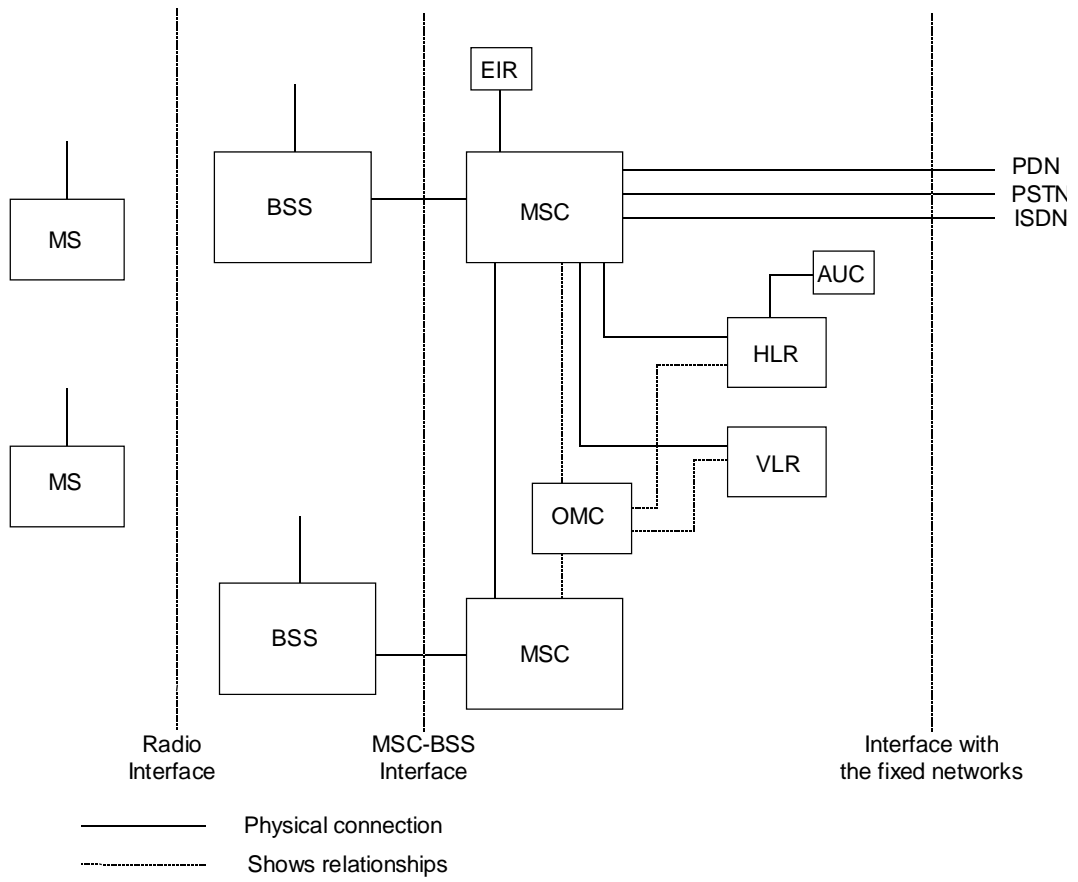

MS: Mobile Station
 BSS: Base Station System
 MSC: Mobile services Switching Centre
 HLR: Home Location Register

VLR: Visited Location Register
 OMC: Operation and Maintenance Centre
 EIR: Equipment Identity Register
 AUC: Authentication Centre

Figure 1

History

Change history					
SMG No.	TDoc. No.	CR. No.	Section affected	New version	Subject/Comments
SMG#17	149/96	A002r1	5.3, 6.3	5.0.0	Addition of handling for VBS and VCGS
Nov. 1998				6.0.0	Upgraded to version 6.0.0
Nov. 1998				6.0.1	Editorially corrected to R97